

E. TROUBLESHOOTING

If the motor does not run:

- Check that you are using fresh batteries.
- Check that the batteries are inserted the correct way round in the battery case.
- Check that the gear and the cog are lubricated
- Check that all four bare pieces of wire are touching the metal terminal caps.

If the Amphibian Rover runs backwards:

- Remove the terminal caps, swap over the wires from the motor and replace the caps.

G. HOW DOES IT WORK?

The Amphibian Rover's wheels are turned by the motor, which turns the electricity from the batteries to movement. There are two sets of gears in the motor case that reduce the turning speed between the motor and the wheels. They also increase the turning force of the motor. The first set of gears is the worm gear and the central cog wheel. One complete turn of the worm gear pushes the cog round by just one tooth. The small cog reduces the turning speed between the central wheel and the axle.

When the Amphibian Rover is on water, the bottles work as floats instead of wheels. But they can't grip the water very well, so the paddles push on the water instead.

H. FUN FACTS

- Your Amphibian Rover can travel on land and water. Vehicles that can do this are called amphibious vehicles or simply amphibians.
- Amphibians are named after group of animals called amphibians, which includes frogs and toads. Amphibians spend some of their lives on land and some in water.
- The military use amphibious vehicles to carry troops and equipment across rivers and from ships to the shore. Amphibians are also used for rescue and in farming.
- There are a few amphibious sports cars that turn into speed boats! The wheels fold up into the body as the car enters the water.
- There are even designs for scuba cars. A scuba car converts from a sports car to mini submarine.
- The first amphibious car was built in 1918.
- James Bond drove an amphibious car in the 1977 movie The Spy Who Loved Me.
- Amphibian Rover's large wheels stop it sinking into soft ground, such as mud. They spread the Rover's weight over a large area. Vehicles that spread weight with large tyres like this are called low-ground-pressure vehicles.
- Most plastic drinks bottles are made from a plastic called polyethylene terephthalate (PET for short). It's identified by a number 1 in the recycling symbol on the bottle.
- PET is recycled to make plastic flakes, which are used to make new containers and fabrics.
- The plastic from twenty-five 2-litre drinks bottle can make the fabric for a new fleece jacket.
- Every year in the USA, a staggering 22 billion plastic water bottles are incinerated or thrown into landfill.

FUN MECHANIC SERIES

Build a better tomorrow through education & awareness. You will like the other great Fun Mechanic kits:



00-03270 Tin Can Robot

Millions of soda can are being wasted daily. Help recycle one of them and turn it into a cool robot which walks in silly movement when it is turned on. It could be turned to a robot monster too. Just cool.



00-03272 Smart Robot

A smart robot which changes its moving path when it hits an obstacle. No remote control or programme chips. It just moves as if it has a brain.



00-03273 Bottle Catamaran

Construct a cool catamaran with this unique science project. Watch your catamaran skim across the water on its pop-bottle floats, pushed by its spinning propeller. Recycle two plastic bottles to make its floats. It's a fun mechanical kit and a recycling project too.

Questions & Comments

We value you as a customer and your satisfaction with this product is important to us. If you have comments or questions, or you find any part of this kit missing or defective, please do not hesitate to contact our distributor in your country. You will find the address printed on the package. You are also welcome to contact our Marketing Support Team: Email: infodesk@4m-ind.com, Fax: (852) 25911566, Tel: (852) 28936241, Web site: WWW.4M-IND.COM

AMPHIBIAN ROVER

To Parents: Please read through these instructions before giving guidance to your children.



A. SAFETY MESSAGES

1. Adult supervision and assistance are required at all times.
2. This kit is intended for children ages over 8.
3. This kit and its finished product contain small parts which may cause choking if misused. Keep away from children under 3 years old.
4. To prevent possible short circuits, never touch the contacts inside the battery case with any metal.
5. If water is splashed onto the battery case or motor housing, dry it with a cloth to prevent rusting. You might need to open the casing to dry inside.

B. USE OF THE BATTERY

1. Requires two 1.5V "AAA" batteries (not included).
2. For best results, always use a fresh batteries.
3. Make sure you insert the batteries with the correct polarities.
4. Remove the batteries from the kit when not in use.
5. Replace exhausted batteries straight away to avoid possible damage to the kit.
6. Rechargeable batteries must be removed from the kit before recharging.
7. Rechargeable batteries should be recharged under adult supervision.
8. Do not attempt to recharge non-rechargeable batteries.
9. Do not mix old and new batteries.
10. Do not mix alkaline, standard (carbon-zinc), or rechargeable (NiCd or NiMH) batteries.
11. Make sure that the supply terminals in the battery case are not short circuited.

C. CONTENTS

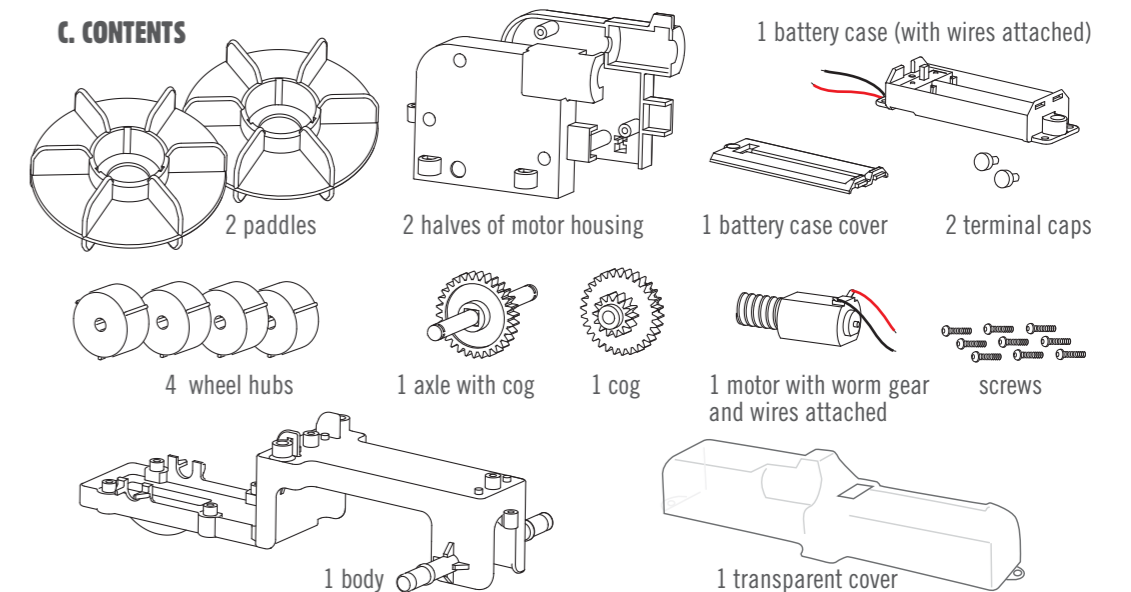

Also required but not included: 2 x 1.5V "AAA" batteries, small crosshead screwdriver and 4 x soda bottles. ►

D. ASSEMBLY

Follow these steps to assemble your Amphibian Rover. Numbers refer to the diagrams.

1. Identify the two halves of the motor housing. One half has a long spindle, which the other does not. Take the half with the spindle and push the motor into place in the slot in its corner. Gently push the red wire from the motor through the hole in the corner.
2. Push the cog onto the short spindle in the centre of the housing, with the larger cog wheel next to the housing. The larger wheel should interlock with the motor's worm gear.
3. Look at the axle with cog. The grey plastic in the centre of the cog is longer on one side than the other. Push the axle on the longer side into the hole in the opposite corner to the motor. Lubricate your gear and cogs. You can use a little cooking oil for this.
4. Now put the two halves of the housing together, making sure the axle and cog stay in place and the black wire is not trapped. Secure the two halves with three screws.
5. Push the completed motor housing into the body so that the cog in the housing fits into the recess in the body. Secure the housing with four screws.
6. Push the battery case onto the two short pins on the body. One wire from the battery case should come out from under each side of the case. Secure the case with two screws.
7. Now you need to connect the wires from the battery case to the wires from the motor. There are two terminal holes on the body between the battery case and the motor housing. Push the bare ends of one wire from the battery case and one wire from the motor into each hole. Push a terminal cap into each hole to trap the wires in place. Match the colours of the wires when doing the connection.
8. Push a wheel hub onto each of the two back axles (the axles fixed to the body), with the flat side closest to the body. The wheel hubs should click into position.
9. Push a wheel hub into the each of the paddles, with the flat side of the hub on the inside. Push the hubs and paddles onto each end of axle in the motor housing.
10. Insert two 1.5 V "AAA" batteries into the battery case. The negative terminal (the flat end) of each battery goes against one of the springs in the battery case. If the motor runs, switch the switch to turn it off. Attach the battery case cover with a screw.
11. Install the transparent cover with 2 screws.
12. Screw a soda bottle into each wheel hub.

Congratulations! Your Amphibian Rover is ready to go!

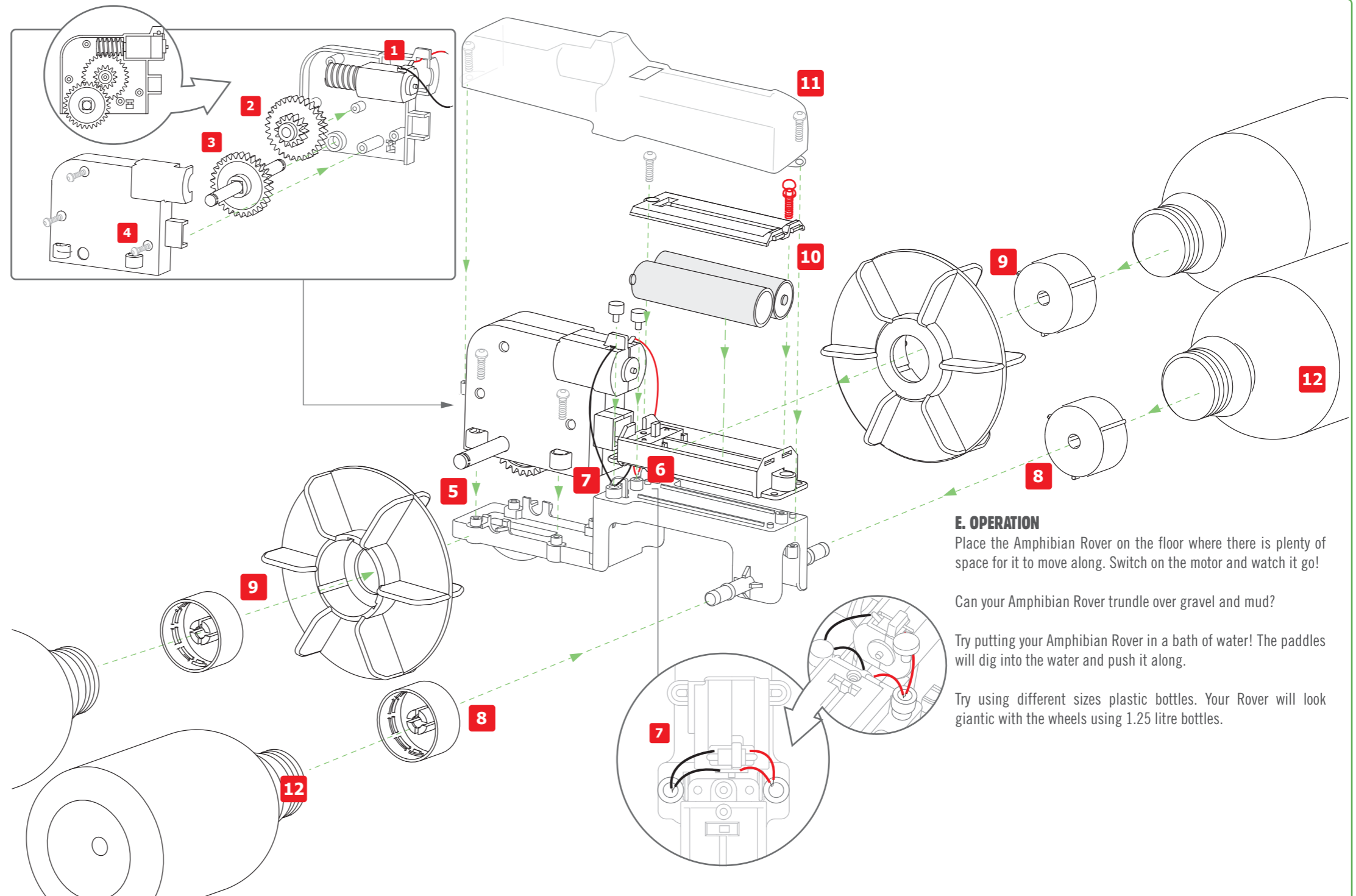

E. OPERATION

Place the Amphibian Rover on the floor where there is plenty of space for it to move along. Switch on the motor and watch it go!

Can your Amphibian Rover trundle over gravel and mud?

Try putting your Amphibian Rover in a bath of water! The paddles will dig into the water and push it along.

Try using different sizes plastic bottles. Your Rover will look gigantic with the wheels using 1.25 litre bottles.