

## 5. MAGNET YACHT

You need: Magnet yacht (C7), magnet wand (C2), a shallow tray from home.

This game shows how magnets work through liquid. Get a shallow tray from home and put it on the table. Pour some water into the tray, just deep enough to float the magnet yacht. You can make a simple sail using a piece of plastic sheet, e.g. from a plastic bag. Fix the sail onto the mast. Put your magnet yacht into the water. Now hold the magnet wand under the tabletop and try moving the yacht around the tray. You will be amazed how your magnets work through the tabletop and water.

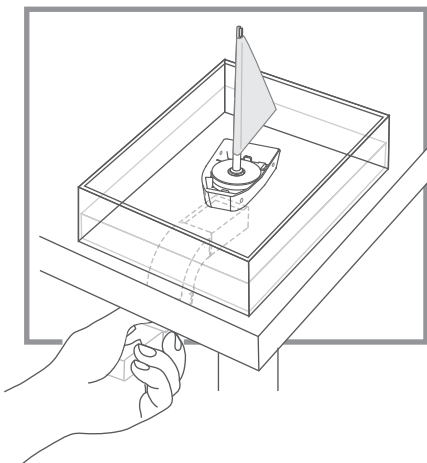

## 6. MYSTERIOUS DANGLER

You need: Magnet fishing wand (C4), bar magnets x 2.

Place the bar magnets on the tabletop at a distance so that they will not attract each other. Now dangle the ring magnet above the bar magnets. You will see the ring magnet dangling in a mysterious movement. This is because the attractive/repelling forces of the two bar magnets are acting on the ring magnet from different directions creating the mysterious movement. Decorate the ring magnet with a UFO graphic, or attach a light figurine onto it, to make it into an amazing show.

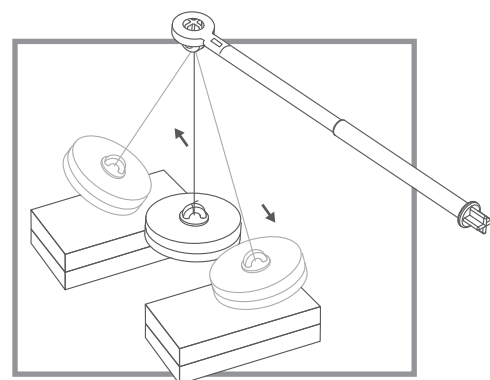

## 7. COMPASS YACHT

You need: Magnet yacht (C7), a compass from home.

Float your magnet yacht on water. Spin the yacht and after a while it will stop and point in a certain direction. Spin it again and you will see the yacht facing the same direction again. Why? The Earth is a big magnet with North and South Poles. The compass needle is a piece of small magnet which is attracted by the Earth's magnetic fields, pointing in the North-South direction. The ring magnet in the boat is attracted to the Earth's magnetic fields in the same way as the compass needle. Wherever you turn the boat it will point in the same direction as the Earth's magnetic fields. Now try adjusting the position of the ring magnet so that the yacht's body aligns with the ring magnet's North-South poles (preferably with the front of the yacht pointing to the North). Now when you put the yacht into the water, its head will always point to the North. Your yacht can now act as a compass!

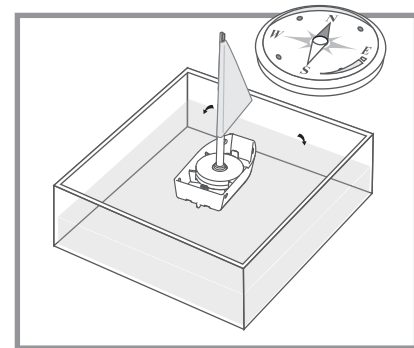

## 8. LEVITRON

You need: Super racer (C6), mini magnet wand (C3), ring magnet x 2.

This simple trick shows how magnets repel each other when the same poles are facing each other. Get the super racer (C6). Insert the fishing wand into the hole on the chassis. Now get a ring magnet and find the pole which repels the bar magnet inside the racer. Insert the ring magnet into the pole. You should see it "floating". Now get another ring magnet. Find the pole which repels that of the first ring magnet. Insert the second ring magnet into the pole. You now see two ring magnets "floating". Now try pressing the magnets together. You will feel a force pushing the magnets apart. When you release them, the ring magnets on top will bounce away from the chassis. This is a fun experiment. It is also fun to move the racer with two rings floating on top. It's a cool levitron racer.

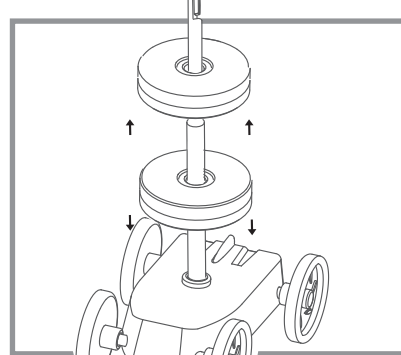

You may also do the experiment by simply using two ring magnets and a fishing wand. Simply insert the wand into the hole of one ring magnet. Stand the wand on the tabletop. Now insert another ring magnet into the wand with the same poles facing each other. You will see the second ring magnet "floating" in mid-air.

## 9. SUPER MAGNET RACER

You need: Bar magnet, super racer (C6).

This game shows how the same magnetic poles repel each other and how a magnet racer is moved by the repelling force. Find the same poles of the super magnet racer and the bar magnet. Now hold the magnet on top of the super magnet racer; you will feel an invisible force which pushes the racer away. Since both are strong magnets and the repelling force is quite strong, the racer is driven to move fast.

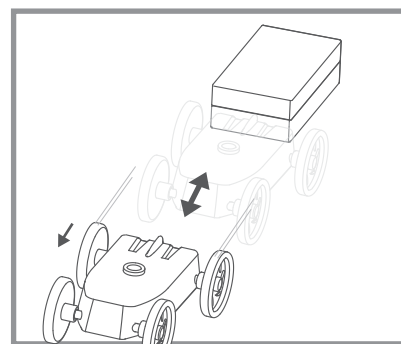

## 10. MAGNETIC SCULPTURE

You need: Bar magnet, metal screw nuts.

Temporary magnets could be created by putting magnetic materials onto a permanent magnet. Place the bar magnet on the table. Now start stacking the metal screw nuts on top of it. You will be amazed how the metal screw nuts are stuck together like magnets. Continue to stack the metal screw nuts and build a piece of mini sculpture. You may also have a competition with

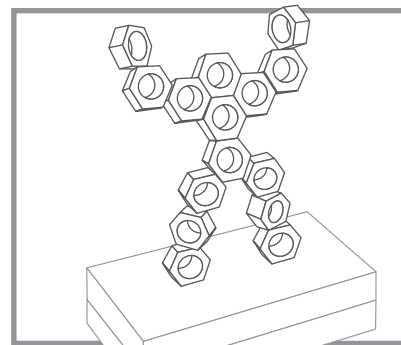

your friends to see who could stack the tallest sculpture. Or you could get some magnetic materials like paper clips, nails, etc. from home to build your very own piece of art. Combine the magnets to get stronger magnetic power to build bigger sculptures. The fun is unlimited.

## E. FUN FACTS

1. A magnet is an object which creates a magnetic field and attracts magnetic materials. In ancient times, both the Greek and the Chinese discovered a certain kind of rare stone which was naturally magnetised. This natural magnet could attract small pieces of iron. When it was tied to a piece of string and allowed to swing, it would always point to the same direction once it has settled. The stone was called Lodestone and was from a place called Magnesia in Greece, where the name 'magnet' is believed to have originated.

2. In production, magnets are made by melting steel and pouring the molten mixture into moulds. The moulds are left in a strong magnetic field for cooling down. They become magnets after they have cooled down and hardened.

3. Magnets are very useful in daily life. You could easily find an application of magnets around you, such as a simple fridge magnet, the magnetic head in a video recorder, magnets in generators for producing electricity, etc.

4. The Earth is a big magnet. All the north poles of magnets point to one place which is called the Earth's magnetic North Pole. It is in Northern Arctic. Explorers found that compasses do not work there, the needle inside the compass just spins.

5. Some scientists believe that birds use the Earth's magnetic field to find their way when travelling long distance. Magnetic crystals have been found in the small skulls of birds which make them sensitive to the Earth's magnetic field.

6. You could break a magnet into small pieces and each piece would have north and south poles just like the original magnet.

## QUESTIONS & COMMENTS

We value you as a customer and your satisfaction with this product is important to us. If you have comments or questions, or you find any part of this kit missing or defective, please do not hesitate to contact our distributor in your country. You will find the address printed on the package. You are also welcome to contact our Marketing Support Team: Email: infodesk@4m-ind.com, Fax (852) 25911566, Tel: (852) 28936241, Web site: WWW.4M-IND.COM

# MAGNET SCIENCE

TO PARENTS: PLEASE READ THROUGH THESE INSTRUCTIONS BEFORE GIVING GUIDANCE TO YOUR CHILDREN.

**WARNING:**  
CHOKING HAZARD – Small parts.  
Not for Children under 3 years.

## A. SAFETY MESSAGES

1. Please read through these instructions before you start.
2. Adult assistance and supervision are recommended.
3. This kit is intended for children over 8 years of age.
4. This kit and its finished product contain small parts which may cause choking if misused. Keep away from children under 3 years old.
5. Use your magnets with care. Magnets could cause damage to electrical appliances like televisions, computer screens etc. They can also erase or mess up audiotapes, videotapes, credit cards, floppy disks. Do not place your magnets near those items mentioned above. Never put your magnets close to pacemakers and hearing aids. Always ask for an adult's assistance when using your magnets.
6. The bar magnets included in this kit are strong and they will attract each other very quickly. Do not put your finger in between the magnets to avoid injury.

## B. CONTENTS

2 super power bar magnets, 2 ring magnets, 1 set magnet handle (can be assembled into magnet wand or U shaped magnet), 1 car/boat chassis, 4 wheels, 1 long axle, 1 short axle, 1 rod for fishing wand/yacht mast, 1 fishing wand joint, 2 ring magnet joints, 10 magnetic fish, 20 metal screw nuts, 1 roll of thread, detailed assembly and game instructions with fun facts and principles of magnetism.

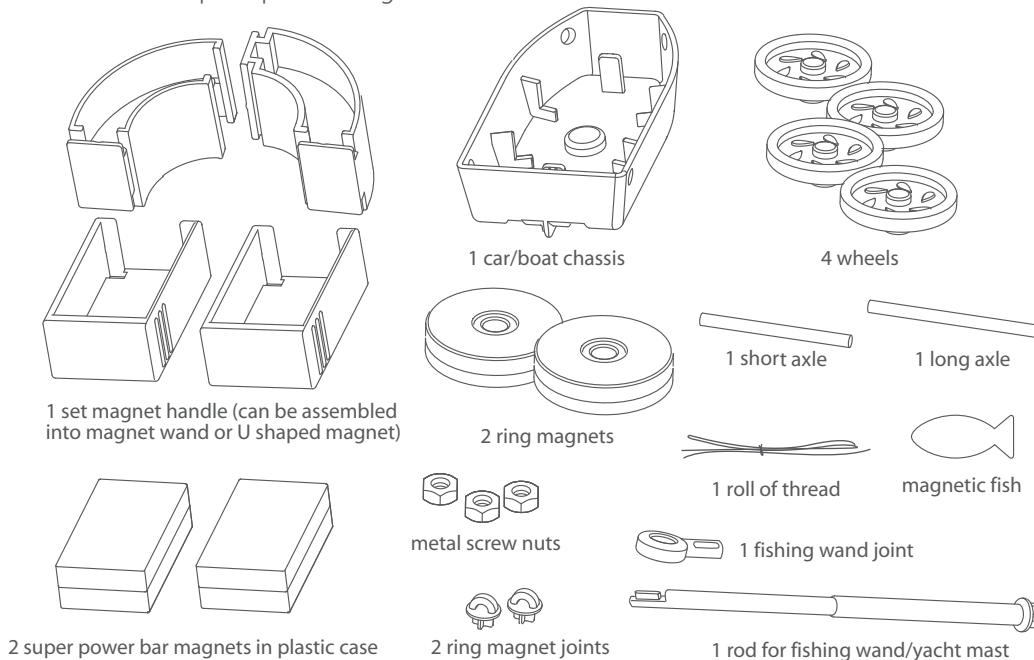

## C. ASSEMBLY (DIAGRAMS C1- C7)

Your Magnet Science kit is specially designed, allowing you to transform your magnets into different gadgets for different purposes.

### C1. U SHAPED MAGNET

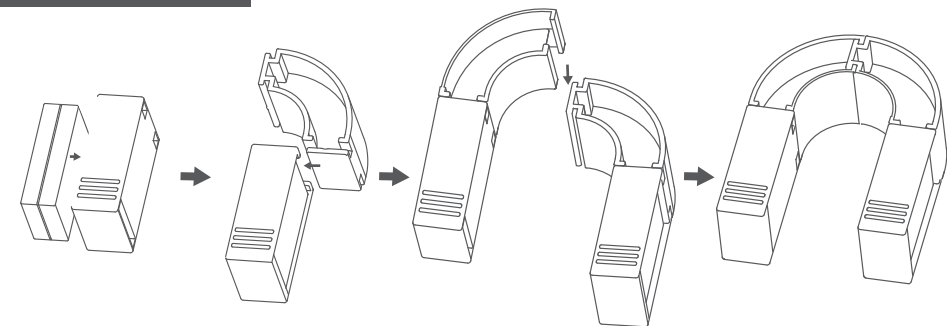

### C2. MAGNET WAND

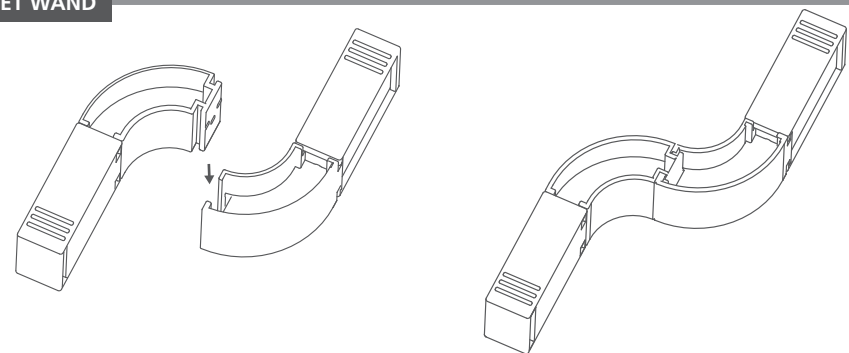

### C3. MINI MAGNET WAND

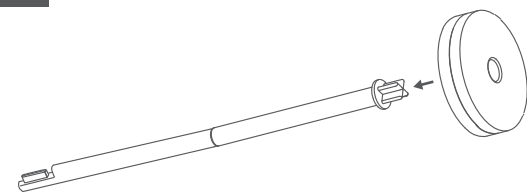

### C4. MAGNET FISHING WAND

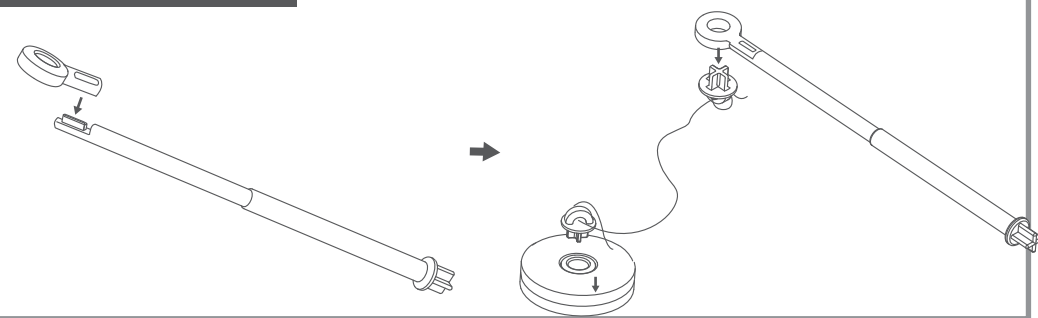

### C5. MAGNET RACER

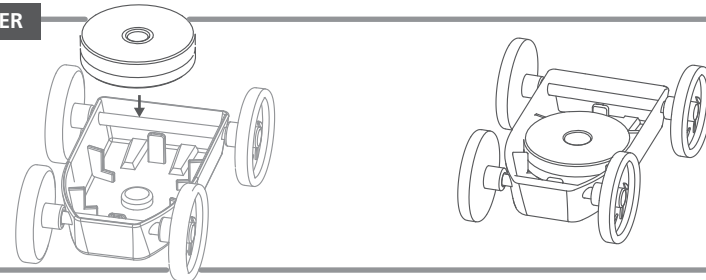

### C6. SUPER RACER

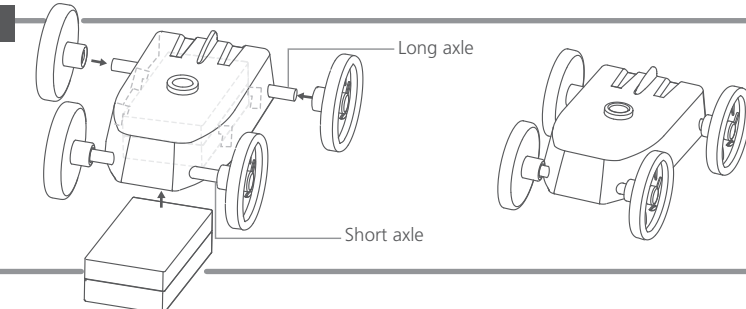

### C7. MAGNET YACHT

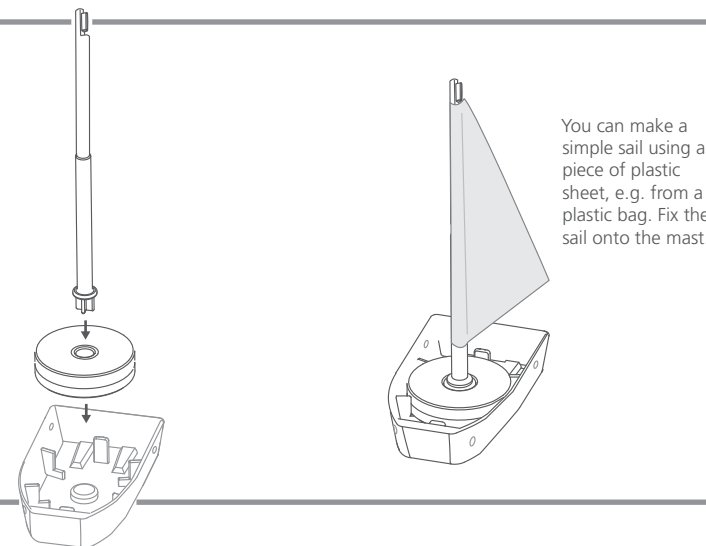

## D. FUN GAMES

Before you start the games, read these basic principles of magnetism to help you understand how this mysterious force of nature works.

1. A magnet has 2 poles, north and south. North pole points north, south pole points south.
2. When two magnets are placed next to each other, like poles repel, unlike poles attract.
3. Magnetic forces attract only magnetic materials.
4. Magnetic forces act at a distance. It could act through air, liquid or solid.
5. While magnetised, magnetic materials will become temporary magnets with properties that are similar to those of permanent magnets.

## 1. MAGNETIC AND NON MAGNETIC EXPERIMENTS

You need: U shaped magnet (C1) or magnet wand (C2).

Only metallic objects could be attracted to magnets. And among all metals, only iron, steel and nickel are magnetic. Other metals like aluminium are not magnetic at all. Try testing the materials around the house and find out if they are magnetic. (Caution: please observe the safety messages of using magnets as mentioned at the beginning of these instructions.) Go to the backyard and try testing the stones too. Some stones contain magnetic materials which could be attracted to magnets. Some cereal products which are fortified with iron could be magnetic too. Just mash and mix them with water. Stir the solution with the magnet wand. You will see a thin coat of material being attracted to the magnet surface; they are iron particles!

## 2. FISHING GAME

You need: Magnet fishing wand (C4), magnetic fish.

Magnetic power can work through liquid. Get a shallow tray at home and fill it with water. Place the magnetic fish into the water and start the game. Attach the ring magnet to the fishing rod and use it to catch as many fish as you can. Time yourself and see how long it takes to catch all the fish. Compete with your friends and see who can catch all the fish in the shortest time. Alternatively, set a time limit and see who can catch the highest number of fish within that time. Have fun playing the game at bath time.

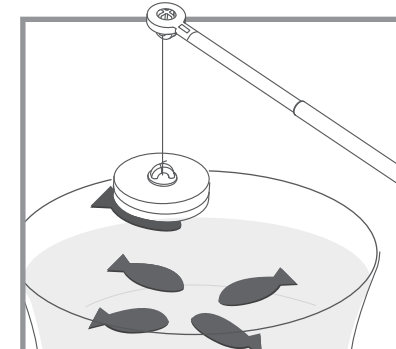
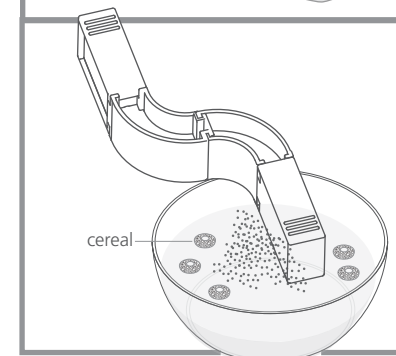
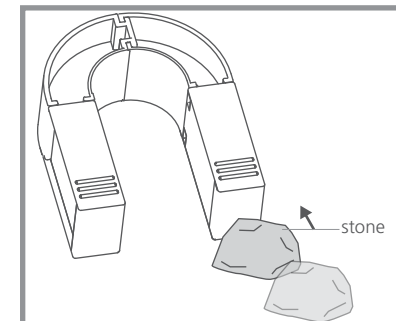

## 3. TABLE UFO

You need: The ring magnet and the thread from the fishing wand (C4), magnet wand with one super magnet only (C2), an additional ring magnet, a bar magnet.

Magnetic force works through air from a reasonable distance. Detach the thread and magnet from the fishing wand. Attach the small joint to another ring magnet. Attract one ring magnet to a bar magnet placed on the table. Use the magnet wand to pick the ring magnet at the loose end until the thread is in full tension (straightened). Pull your wand a bit away from the ring magnet so that they are detached. You will see that the magnet wand still holds the ring magnet in place even without touching it. The ring magnet is like a UFO floating in mid air. You could also decorate the ring magnet with pictures of a kite, a flower, a butterfly or a UFO to make the show more interesting. You could also replace the ring magnet with other magnetic materials like paper clips. Your friends and family will be amazed by this small trick.

## 4. MAGNET RACER

You need: Magnet racer (C6), magnet wand (C2).

Magnetic power works through solid too. Your super power magnets are strong enough to work through a tabletop. Construct your racer using the chassis, ring magnet and wheels. Put different things (best to use non magnetic ones) on your tabletop to create your own obstacle course. You could use your books, boxes, stationery, etc. for this purpose. Remember to put up "START" and "FINISH" signs for more fun. Now hold your magnet wand under the tabletop. Position it until it is attracted to your magnet racer. Move the magnet racer along the obstacle course until it gets to the "FINISH" point.

