

**TO PARENTS: PLEASE READ THROUGH THESE INSTRUCTIONS BEFORE GIVING GUIDANCE TO YOUR CHILDREN.**

**WARNING: CHOKING HAZARD - Small parts. Not for Children under 3 years.**

# SALT-POWERED ROBOT

## A. SAFETY MESSAGES

1. Read carefully through all these instructions before you start.
2. Identify the contents of the kit before you start putting the parts together.
3. Adult supervision is required throughout.
4. This kit and its finished product contain small parts which may cause choking if misused. Keep away from children under 3 years old.
5. To prevent possible short circuits, never touch the contacts, aluminium sheet, fabric sheet, or carbon sheets with any metal.

## B. CONTENTS

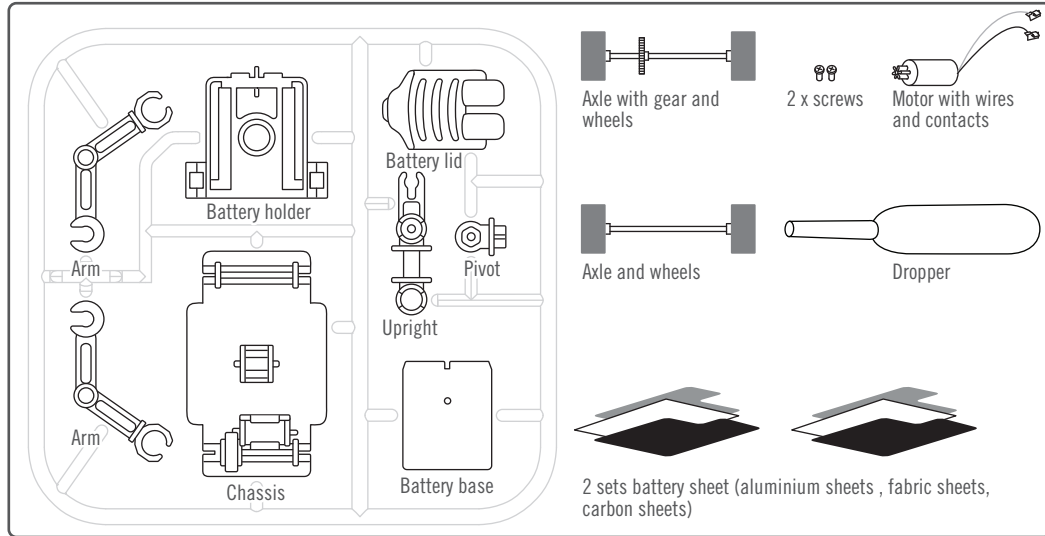

You will also need from home: cup, table salt, spoon

## C. ASSEMBLY

Before you start assembling, gently twist and detach all parts from the plastic frame. You may use a nail clipper to trim away any excess plastic from the parts.

### ASSEMBLING THE ROBOT

1. Identify the two ends of the chassis. One end has a space for the small motor. Clip the axle with the gear onto this end, making sure the gear fits into the slot. Clip the other axle into the other end of the chassis.
2. Carefully slot the motor into position, making sure that the gear on the motor interlocks with the gear on the axle.
3. Push the pin on the pivot into the hole on the upright as shown.
4. Clip the two arms onto the upright.
5. Clip the bottom of the upright onto the centre of the chassis.
6. Identify the battery, push the terminal on the red wire into the slot, pointing to a "R" on the base, and the terminal on the blue wire into the slot, pointing to a "B" on the base.
7. Push the battery holder onto the pivot of the upright.
8. Push the two screws to the battery holder, to be the 'eyes' of the robot.

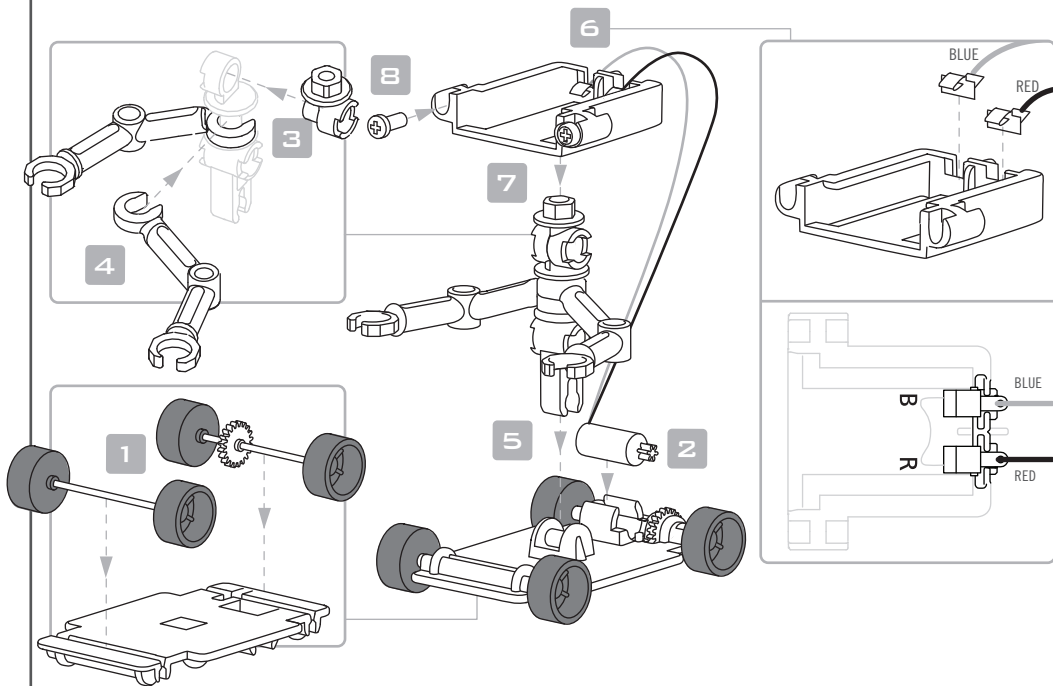

### ASSEMBLING THE SALT WATER BATTERY

1. Now make the battery itself. Put an aluminium sheet into the battery base, making sure you have the tab on top of the slot marked "A".
2. Put a sheet of fabric on top of the aluminium.
3. Finally put a carbon sheet on top of the fabric, making sure the tab is on the opposite side on top of the slot mark "C".
4. Clip the battery lid onto the base, trapping the sheets in place.

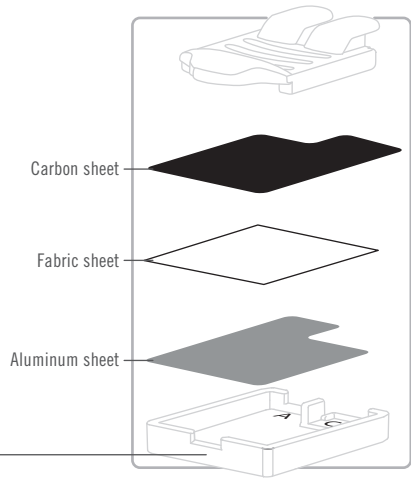

## D. OPERATION

1. Pour some water into a cup until the water is about 2 cm (4/5 in.) deep. Add some salt to the water and stir to make the salt dissolve. Keep adding salt until no more will dissolve.
2. Take the dropper and suck up some of the salt water.
3. Now squeeze a few drops of the water through the battery lid so that it soaks into the fabric. Put the robot on a smooth, flat surface. Carefully push the battery into the battery holder. The robot should whizz along as the electricity from the battery reaches the motor.

To stop the robot, you need to remove the battery from the battery case. Wash it with clean water. Separate the aluminium and carbon sheets and leave them to dry. If you do not separate them, the reaction will continue to take place and all energy will be drained away. You can reuse the battery sheets following the instructions above. A set of battery sheets will last continuously for approximately an hour. If the energy is used up, you need to use a new set of battery sheets. Note: contact our customer service, at [www.4m-ind.com](http://www.4m-ind.com) if you would like to order a refill battery set.

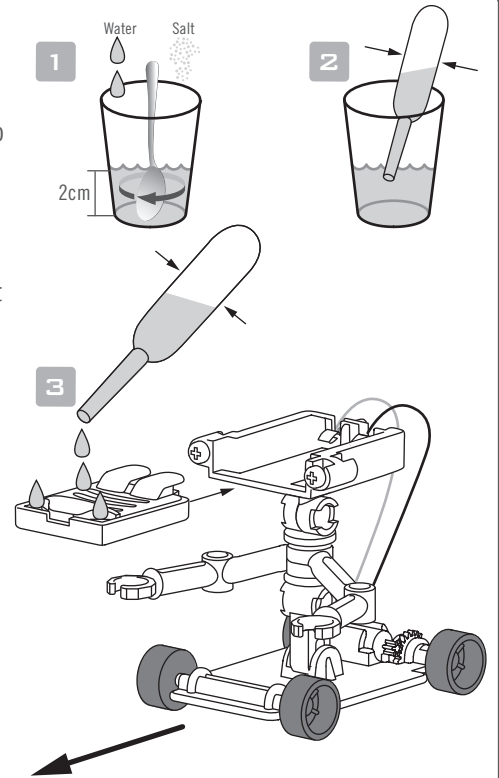

## E. TROUBLESHOOTING

If the motor does not turn when you put the battery into the battery holder:

- You may have to spin the robot's wheels with your fingers to get the motor started.
- Check that the metal terminals on the wires are touching the carbon and aluminium sheets. You may gently bend the metal contact downwards. This will secure a better contact with the battery sheets.
- Make sure the sheets are not touching each other.

If your robot runs backward:

- You might have reversed the polarities of the wires or the positions of the aluminum sheets. Check all connection or batteries assembly as above instruction.

If the battery loses power:

- Try adding a few more drops of salt water to the fabric.
- Scratch the tab on the aluminium sheet and the metal terminals with the end of a screwdriver to remove any deposits that might be stopping electricity flowing.
- After an hour, the aluminium in the sheet will be used up, so you will need to replace the sheet. Replace the carbon sheet and fabric at the same time.

## E HOW IT WORKS

The aluminium, salt water and carbon form a battery, and this makes electricity that turns the motor. A battery with these parts is called an an aluminium-air battery. That's because it produces electricity from a chemical reaction between the aluminium and oxygen from the air. The aluminium combines with the oxygen to make aluminium oxide. The reaction releases energy in the form of electricity.

In the battery several things are happening when the battery is giving out electricity. The electric current that makes the motor work is made up of a flow of tiny particles called electrons. At the carbon sheet, oxygen from the air and water from the fabric combine with electrons coming along the wire from the motor. This makes particles called hydroxide ions in the water. At the aluminium sheet, hydroxide ions in the water combine with the aluminium to make aluminium oxide, and some electrons that flow down the wire to the motor.

Salt is a material called sodium chloride. When salt dissolves in water, it splits up into sodium ions and chlorine ions. These move through the water, carrying electric charge from the carbon to the aluminium. So overall, as the aluminium is turned to aluminium oxide, electrons flow out of the aluminium and into the carbon. They make up an electric current that makes the motor work.

## G. FUN FACTS

- All batteries have two electrodes. In this battery, aluminium is one electrode, and oxygen from the air is the other electrode.
- Batteries are named after the chemicals used to make their electrodes. Common batteries are such as zinc-carbon, lithium-ion (Li-ion for short), nickel-cadmium (Ni-Cad for short).
- The first battery was made by Italian scientist Alessandro Volta in 1800. It was known as a voltaic pile.
- You can make an aluminium-air battery from a soda can (which is made from aluminium) and barbecue charcoal!
- An aluminium-air battery gives out about three times as much energy as a lithium-ion battery (used in mobile phones and other small devices) of the same weight. It is better for the environment because fewer batteries are needed for the same job.
- Aluminium-air batteries are very promising for use in electric cars, although there are some technical problems overcome to make them work well. Electric cars don't give out the pollution that cars with petrol and diesel engines do.
- At the moments they have only military applications. In the future US soldiers may have personal power packs with aluminium-air batteries to work their equipment.
- Iron-air batteries are also a promising new battery technology. They work in the same way as aluminium-air batteries. Iron-air batteries are rechargeable, which means they can be used many times before they have to be thrown away. Even then, the materials inside are easy to recycle to make new batteries. So these batteries harm the environment much less than other types of battery.
- Iron-air batteries can store lots of energy for their size. They will be good for storing energy from renewable sources, such as wind turbines and solar panels, so that the energy can be stored later.

## QUESTIONS & COMMENTS

We value you as a customer and your satisfaction with this product is important to us. If you have comments or questions, or you find any part of this kit missing or defective, please do not hesitate to contact our distributor in your country. You will find the address printed on the package. You are also welcome to contact our Marketing Support Team: Email: [infodesk@4m-ind.com](mailto:infodesk@4m-ind.com), Fax (852) 25911566, Tel: (852) 28936241, Web site: [WWW.4M-IND.COM](http://WWW.4M-IND.COM)