

Robert Bosch GmbH

Power Tools Division
70745 Leinfelden-Echterdingen
Germany

www.bosch-pt.com

1 609 929 Y19 (2011.03) T / 180 UNI



1 609 929 Y19

GEX Professional

125 A | 125 AC | 150 AC



de Originalbetriebsanleitung
en Original instructions
fr Notice originale
es Manual original
pt Manual original
it Istruzioni originali
nl Oorspronkelijke
gebruiksaanwijzing
da Original brugsanvisning
sv Bruksanvisning i original
no Original driftsinstruks
fi Alkuperäiset ohjeet

el Πρωτότυπο οδηγιών χρήσης
tr Orijinal işletme talimatı
pl Instrukcja oryginalna
cs Původní návod k používání
sk Pôvodný návod na použitie
hu Eredeti használati utasítás
ru Оригинальное руководство по
эксплуатации
uk Оригінальна інструкція з
експлуатації
ro Instrucțiuni originale
bg Оригинална инструкция

sr Originalno uputstvo za rad
sl Izvirna navodila
hr Originalne upute za rad
et Algupärane kasutusjuhend
lv Instrukcijas oriģinālvalodā
lt Originali instrukcija
ar تعليمات التشغيل الأصلية
fa راهنمای طرز کار اصلی





4 |

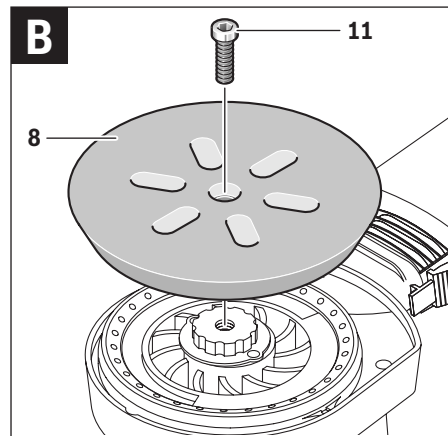
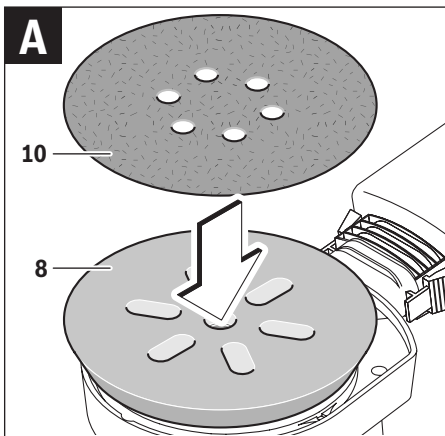
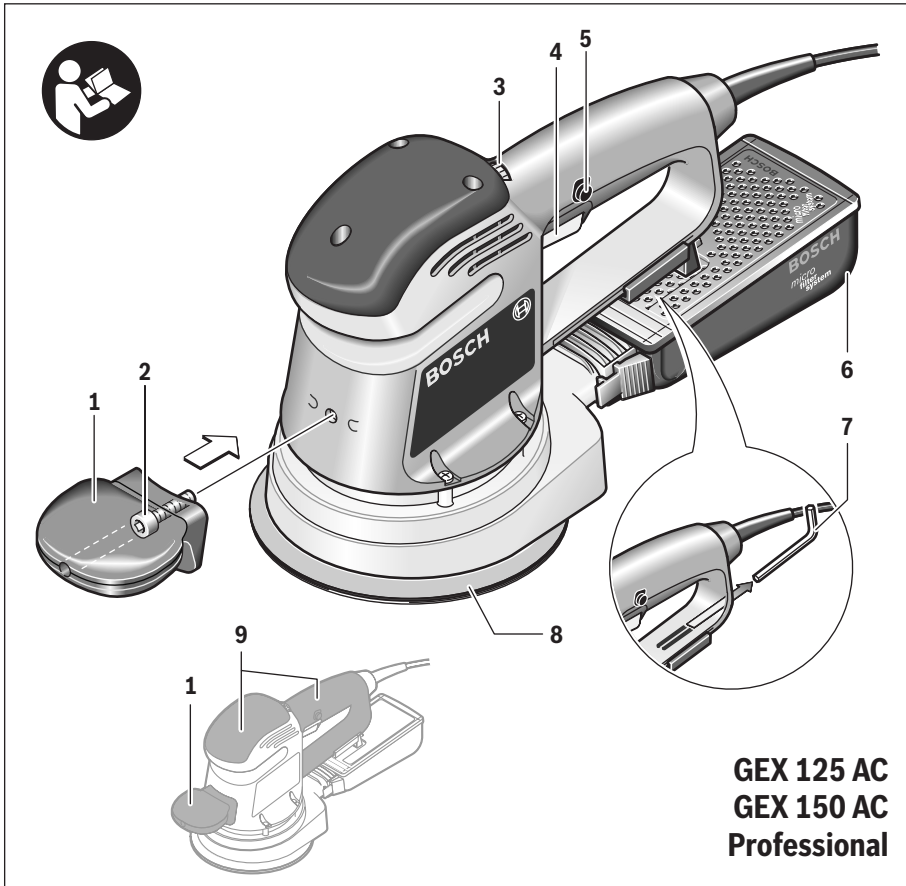

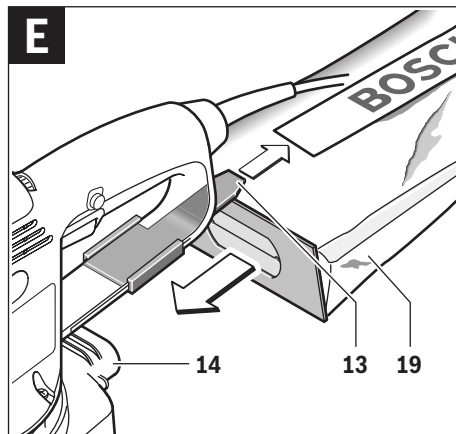
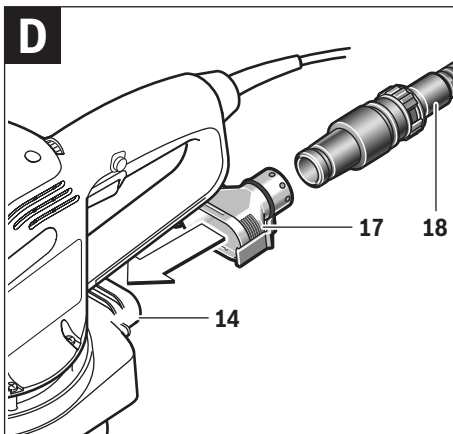
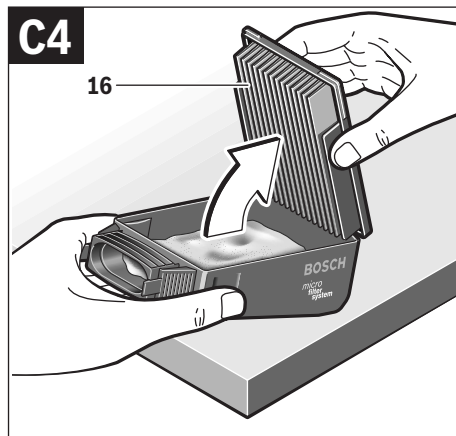
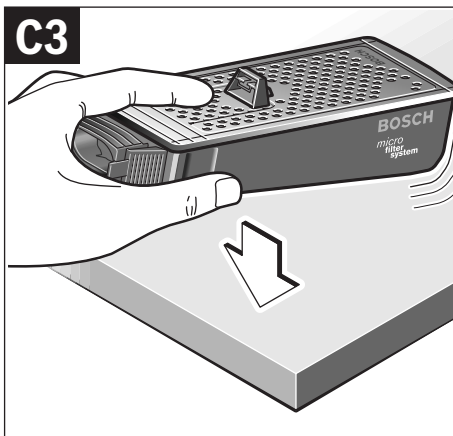
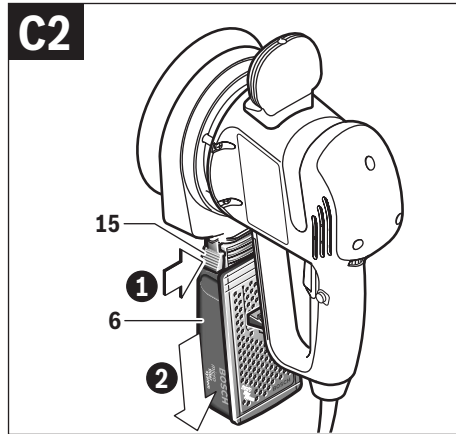
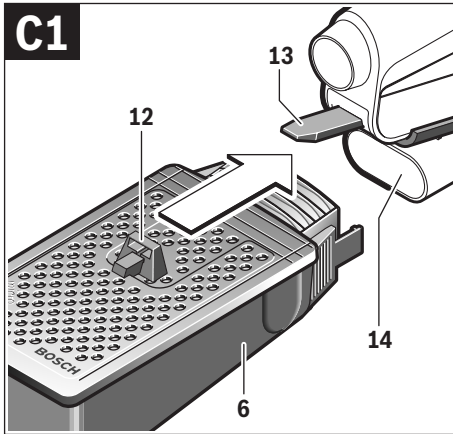

English

Safety Notes

General Power Tool Safety Warnings

⚠ WARNING Read all safety warnings and all instructions. Failure to follow the warnings and instructions may result in electric shock, fire and/or serious injury.

Save all warnings and instructions for future reference.

The term "power tool" in the warnings refers to your mains-operated (corded) power tool or battery-operated (cordless) power tool.

Work area safety

- ▶ **Keep work area clean and well lit.** Cluttered or dark areas invite accidents.
- ▶ **Do not operate power tools in explosive atmospheres, such as in the presence of flammable liquids, gases or dust.** Power tools create sparks which may ignite the dust or fumes.
- ▶ **Keep children and bystanders away while operating a power tool.** Distractions can cause you to lose control.

Electrical safety

- ▶ **Power tool plugs must match the outlet. Never modify the plug in any way. Do not use any adapter plugs with earthed (grounded) power tools.** Unmodified plugs and matching outlets will reduce risk of electric shock.
- ▶ **Avoid body contact with earthed or grounded surfaces, such as pipes, radiators, ranges and refrigerators.** There is an increased risk of electric shock if your body is earthed or grounded.
- ▶ **Do not expose power tools to rain or wet conditions.** Water entering a power tool will increase the risk of electric shock.
- ▶ **Do not abuse the cord. Never use the cord for carrying, pulling or unplugging the power tool. Keep cord away from heat, oil, sharp edges and moving parts.** Damaged or entangled cords increase the risk of electric shock.
- ▶ **When operating a power tool outdoors, use an extension cord suitable for outdoor use.** Use of a cord suitable for outdoor use reduces the risk of electric shock.
- ▶ **If operating a power tool in a damp location is unavoidable, use a residual current device (RCD) protected supply.** Use of an RCD reduces the risk of electric shock.

Personal safety

- ▶ **Stay alert, watch what you are doing and use common sense when operating a power tool. Do not use a power tool while you are tired or under the influence of drugs, alcohol or medication.** A moment of inattention while operating power tools may result in serious personal injury.
- ▶ **Use personal protective equipment. Always wear eye protection.** Protective equipment such as dust mask, non-skid safety shoes, hard hat, or hearing protection used for appropriate conditions will reduce personal injuries.

- ▶ **Prevent unintentional starting. Ensure the switch is in the off-position before connecting to power source and/or battery pack, picking up or carrying the tool.** Carrying power tools with your finger on the switch or energising power tools that have the switch on invites accidents.
- ▶ **Remove any adjusting key or wrench before turning the power tool on.** A wrench or a key left attached to a rotating part of the power tool may result in personal injury.
- ▶ **Do not overreach. Keep proper footing and balance at all times.** This enables better control of the power tool in unexpected situations.
- ▶ **Dress properly. Do not wear loose clothing or jewelry. Keep your hair, clothing and gloves away from moving parts.** Loose clothes, jewellery or long hair can be caught in moving parts.
- ▶ **If devices are provided for the connection of dust extraction and collection facilities, ensure these are connected and properly used.** Use of dust collection can reduce dust-related hazards.

Power tool use and care

- ▶ **Do not force the power tool. Use the correct power tool for your application.** The correct power tool will do the job better and safer at the rate for which it was designed.
- ▶ **Do not use the power tool if the switch does not turn it on and off.** Any power tool that cannot be controlled with the switch is dangerous and must be repaired.
- ▶ **Disconnect the plug from the power source and/or the battery pack from the power tool before making any adjustments, changing accessories, or storing power tools.** Such preventive safety measures reduce the risk of starting the power tool accidentally.
- ▶ **Store idle power tools out of the reach of children and do not allow persons unfamiliar with the power tool or these instructions to operate the power tool.** Power tools are dangerous in the hands of untrained users.
- ▶ **Maintain power tools. Check for misalignment or binding of moving parts, breakage of parts and any other condition that may affect the power tool's operation. If damaged, have the power tool repaired before use.** Many accidents are caused by poorly maintained power tools.
- ▶ **Keep cutting tools sharp and clean.** Properly maintained cutting tools with sharp cutting edges are less likely to bind and are easier to control.
- ▶ **Use the power tool, accessories and tool bits etc. in accordance with these instructions, taking into account the working conditions and the work to be performed.** Use of the power tool for operations different from those intended could result in a hazardous situation.

Service

- ▶ **Have your power tool serviced by a qualified repair person using only identical replacement parts.** This will ensure that the safety of the power tool is maintained.

Safety Warnings for Sander

- ▶ **Use the machine only for dry sanding.** Penetration of water into the machine increases the risk of an electric shock.
- ▶ **Pay attention that no persons are put at risk through sparking. Remove any combustible materials in the vicinity.** Sparking occurs when sanding metal materials.
- ▶ **Caution, fire hazard! Avoid overheating the object being sanded as well as the sander. Always empty the dust collector before taking breaks.** In unfavourable conditions, e. g., when sparks emit from sanding metals, sanding debris in the dust bag, micro filter or paper sack (or in the filter sack or filter of the vacuum cleaner) can self-ignite. Particularly when mixed with remainders of varnish, polyurethane or other chemical materials and when the sanding debris is hot after long periods of working.
- ▶ **When working with the machine, always hold it firmly with both hands and provide for a secure stance.** The power tool is guided more secure with both hands.
- ▶ **Secure the workpiece.** A workpiece clamped with clamping devices or in a vice is held more secure than by hand.
- ▶ **Products sold in GB only:** Your product is fitted with a BS 1363/A approved electric plug with internal fuse (ASTA approved to BS 1362).
If the plug is not suitable for your socket outlets, it should be cut off and an appropriate plug fitted in its place by an authorised customer service agent. The replacement plug should have the same fuse rating as the original plug.
The severed plug must be disposed of to avoid a possible shock hazard and should never be inserted into a mains socket elsewhere.
- ▶ **Products sold in AUS and NZ only:** Use a residual current device (RCD) with a rated residual current of 30 mA or less.

Product Description and Specifications



Read all safety warnings and all instructions. Failure to follow the warnings and instructions may result in electric shock, fire and/or serious injury.

While reading the operating instructions, unfold the graphics page for the machine and leave it open.

Intended Use

The machine is intended for dry sanding of wood, plastic, metal, filler as well as coated surfaces. Machines with electronic control are also suitable for polishing.

Product Features

The numbering of the product features refers to the illustration of the machine on the graphics page.

- 1 Auxiliary handle (insulated gripping surface)*
- 2 Screw for auxiliary handle*
- 3 Thumbwheel for orbit frequency preselection (GEX 125 AC/GEX 150 AC)
- 4 On/Off switch
- 5 Lock-on button for On/Off switch
- 6 Dust box, complete (Microfilter System)*
- 7 Allen key
- 8 Sanding plate
- 9 Handle (insulated gripping surface)
- 10 Sanding sheet*
- 11 Screw for fastening the sanding plate
- 12 Holder for dust box*
- 13 Plastic slider
- 14 Extraction outlet
- 15 Latching lever for dust box*
- 16 Filter element (Microfilter System)*
- 17 Extraction adapter*
- 18 Vacuum hose*
- 19 Dust bag*

*Accessories shown or described are not part of the standard delivery scope of the product. A complete overview of accessories can be found in our accessories program.

14 | English

Technical Data

Random Orbital Sander						
GEX ... Professional		125 A	125 AC	125 AC	150 AC	150 AC
Article number	0 601 ...	372 0..	372 4..	372 5..	372 6..	372 7..
Dust box included in delivery scope		-	●	-	●	-
Preselection of orbital stroke rate		-	●	●	●	●
Rated power input	W	340	340	340	340	340
No-load speed	min ⁻¹	12000	4500–12000	4500–12000	4500–12000	4500–12000
No-load orbital stroke rate	min ⁻¹	24000	9000–24000	9000–24000	9000–24000	9000–24000
Orbit diameter	mm	5.0	5.0	5.0	4.0	4.0
Sanding plate diameter	mm	125	125	125	150	150
Weight according to EPTA-Procedure 01/2003	kg	1.9	2.0	2.0	2.1	2.1
Protection class		□/II	□/II	□/II	□/II	□/II

The values given are valid for a nominal voltage [U] of 230 V. For different voltages and models for specific countries, these values can vary.

Please observe the article number on the type plate of your machine. The trade names of the individual machines may vary.

Noise/Vibration Information

Measured sound values determined according to EN 60745.

Typically the A-weighted sound pressure level of the product is 75 dB(A). Uncertainty K = 3 dB.

The noise level when working can exceed 80 dB(A).

Wear hearing protection!

Vibration total values (triax vector sum) determined according to EN 60745:

Vibration emission value $a_h = 4.0 \text{ m/s}^2$, Uncertainty $K = 1.5 \text{ m/s}^2$.

The vibration emission level given in this information sheet has been measured in accordance with a standardised test given in EN 60745 and may be used to compare one tool with another. It may be used for a preliminary assessment of exposure.

The declared vibration emission level represents the main applications of the tool. However if the tool is used for different applications, with different accessories or poorly maintained, the vibration emission may differ. This may significantly increase the exposure level over the total working period.

An estimation of the level of exposure to vibration should also take into account the times when the tool is switched off or when it is running but not actually doing the job. This may significantly reduce the exposure level over the total working period.

Identify additional safety measures to protect the operator from the effects of vibration such as: maintain the tool and the accessories, keep the hands warm, organisation of work patterns.

Declaration of Conformity 

We declare under our sole responsibility that the product described under "Technical Data" is in conformity with the following standards or standardization documents: EN 60745 according to the provisions of the directives 2004/108/EC, 2006/42/EC.

Technical file at:

Robert Bosch GmbH, PT/ESC,
D-70745 Leinfelden-Echterdingen

Dr. Egbert Schneider
Senior Vice President
Engineering

Dr. Eckerhard Strötgen
Head of Product
Certification

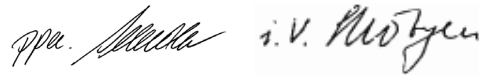

Robert Bosch GmbH, Power Tools Division
D-70745 Leinfelden-Echterdingen
Leinfelden, 15.12.2010

Assembly

► **Before any work on the machine itself, pull the mains plug.**

Replacing the Sanding Sheet (see figure A)

When attaching a new sanding sheet, remove any dust or debris from the sanding plate **8**, e. g., with a brush.

The surface of the sanding plate **8** is fitted with Velcro backing for quick and easy fastening of sanding sheets with Velcro adhesion.

Press the sanding sheet **10** firmly against the bottom side of the sanding plate **8**.

To ensure optimum dust extraction, pay attention that the punched holes in the sanding sheet match with the holes in the sanding plate.

Selecting the Sanding Sheet

Depending on the material to be worked and the required rate of material removal, different sanding sheets are available:

Material	Application	Grain size			
best for Paint – Paint – Varnish – Filling compound – Filler	For sanding off paint	coarse	40 60		
	For sanding primer (e. g., for removing brush dashes, drops of paint and paint run)	medium	80 100 120		
			For final sanding of primers before coating	fine	180 240 320 400
					Expert for Wood – All wooden materials (e. g., hardwood, softwood, chip-board, building board)
	For face sanding and planing small irregularities	medium			
			best for Wood Best for Wood – Hardwood – Particle Board – Building board – Metal materials	For finish and fine sanding of wood	fine
best for Stone – Automotive paint – Masonry, stone – Marble – Granite – Ceramic – Glass – Plexiglas – Glass-fibre plastics	For pre-sanding	coarse		80	
	For shaping and braking edges	medium		100 120	
				For final sanding and forming	fine
For polish-sanding and rounding off edges	very fine	600 1200			

Selection of the Sanding Plate

Depending on the application, the machine can be equipped with sanding plates of different hardness:

- Soft sanding plate: Suitable for polishing and sensitive sanding (also for curved surfaces).
- Medium sanding plate: Suitable for all sanding applications and general-purpose use.
- Hard sanding plate: Suitable for high sanding capacity on flat surfaces.

Replacing the Sanding Plate (see figure B)

Note: Replace a damaged sanding plate **8** immediately.

Pull off the sanding sheet or polishing tool. Completely unscrew the screw **11** and take off the sanding plate **8**. Attach the new sanding plate **8** and tighten the screw again.

Note: When attaching the sanding plate, pay attention that the toothing of the drive element engage into the openings of the sanding plate.

Dust/Chip Extraction

- ▶ Dusts from materials such as lead-containing coatings, some wood types, minerals and metal can be harmful to one's health. Touching or breathing-in the dusts can cause allergic reactions and/or lead to respiratory infections of the user or bystanders.

Certain dusts, such as oak or beech dust, are considered as carcinogenic, especially in connection with wood-treatment additives (chromate, wood preservative). Materials containing asbestos may only be worked by specialists.

- As far as possible, use a dust extraction system suitable for the material.
 - Provide for good ventilation of the working place.
 - It is recommended to wear a P2 filter-class respirator.
- Observe the relevant regulations in your country for the materials to be worked.

- ▶ **Prevent dust accumulation at the workplace.** Dusts can easily ignite.

16 | English

**Integrated Dust Extraction with Dust Box
(see figures C1 – C4)**

Before assembling the dust box **6**, pull out the plastic slider **13**. Place the dust box **6** onto the extraction outlet **14** and allow it to engage. Make sure that the plastic slider **13** engages in the holder **12**.

To empty the dust box **6**, press the latching levers **15** on the side of the dust box (●). Pull off the dust box toward the bottom (●).

Before opening the dust box **6**, it is recommended to loosen the dust from the filter element by gently striking it against a firm support (as shown in the figure).

Grasp the dust box **6** by the recessed grip, fold the filter element **16** upward and empty the dust box. Clean the thin plates of the filter element **16** with a soft brush.

External Dust Extraction (see figure D)

Slide the extraction adapter **17** onto the outlet piece **14**. Ensure that the latching levers of the extraction adapter engage. The extraction adapter **17** accepts a vacuum hose with a diameter of 19 mm.

For removal of the extraction adapter **17**, press the latching levers together at the rear and pull the extraction adapter off. The vacuum cleaner must be suitable for the material being worked.

When vacuuming dry dust that is especially detrimental to health or carcinogenic, use a special vacuum cleaner.

Internal Dust Extraction with Dust Bag (see figure E)

For small sanding jobs, a dust bag (accessory) **19** can be connected.

Before mounting the dust bag **19**, pull out the plastic slider **13**. Slide the dust-bag sleeve firmly over the extraction outlet **14**. Pay attention that the plastic slider **13** engages in the holder intended for it on the dust bag **19**.

To maintain optimum dust collection, empty the dust bag **19** in good time.

Auxiliary Handle

The auxiliary handle **1** enables convenient handling and optimal distribution of power, especially at high removal rates.

Fasten the auxiliary handle **1** with screw **2** to the casing.

Operation**Starting Operation**

- **Observe correct mains voltage! The voltage of the power source must agree with the voltage specified on the nameplate of the machine. Power tools marked with 230 V can also be operated with 220 V.**

Switching On and Off

To **start** the machine, press the On/Off switch **4** and keep it pressed.

To lock the **pressed** On/Off switch **4**, press the lock-on button **5**.

To **switch off** the machine, release the On/Off switch **4** or when it is locked with the lock-on button **5**, briefly press the On/Off switch **4** and then release it.

**Preselecting the Orbital Stroke Rate
(GEX 125 AC/GEX 150 AC)**

With the thumbwheel for preselection of the orbital stroke rate **3**, you can preselect the required orbital stroke rate, even during operation.

1 – 2	Low stroke rate
3 – 4	Medium stroke rate
5 – 6	High stroke rate

The required stroke rate depends on the material and the working conditions and can be determined through practical testing.

The constant electronic control keeps the stroke rate almost constant under no-load or load conditions and ensures a uniform working performance.

After longer periods of working at low stroke rate, allow the machine to cool down by running it for approx. 3 minutes at maximum stroke rate with no load.

Sanding Plate Brake

An integrated sanding plate brake reduces the stroke rate when running at no-load so that scoring is prevented when placing the machine onto the workpiece.

If the no-load stroke rate continuously increases over the course of time, then the sanding plate is damaged and must be replaced or the sanding plate brake is worn. A worn sanding plate brake must be replaced by an authorised after-sales service agent for Bosch power tools.

Working Advice

- **Before any work on the machine itself, pull the mains plug.**
- **Wait until the machine has come to a standstill before placing it down.**

Sanding Surfaces

Switch the machine on, place it with the complete sanding surface on the surface to be worked and move the machine with moderate pressure over the workpiece.

The removal capacity and the sanding pattern are mainly determined by the selection of the sanding sheet, the preselected orbital stroke rate (GEX 125 AC/GEX 150 AC) and the applied pressure.

Only flawless sanding sheets achieve good sanding capacity and extend the service life of the machine.

Pay attention to apply uniform sanding pressure; this increases the working life of the sanding sheets.

Intensifying the sanding pressure does not lead to an increase of the sanding capacity, but to increased wear of the machine and the sanding sheet.

A sanding sheet that has been used for metal should not be used for other materials.

Use only original Bosch sanding accessories.

Rough Sanding

Attach a sanding sheet with coarse grain.

Apply only light pressure to the machine so that it runs at a higher stroke rate and high material removal is achieved.

Fine Sanding

Attach a sanding sheet with fine grain.

By lightly varying the application pressure or changing the orbital stroke rate (GEX 125 AC/GEX 150 AC), the sanding plate stroke rate can be reduced whereby the orbital action is maintained.

With moderate pressure, move the machine in a circular pattern or alternately in lengthwise and crosswise directions over the workpiece. Do not tilt the machine to avoid sanding through the workpiece (e. g. when sanding veneer).

After finishing the working procedure, switch the power tool off.

Polishing (GEX 125 AC/GEX 150 AC)

For the polishing of weathered paint or buffing out scratches (e. g., acrylic glass), the machine can be equipped with appropriate polishing accessories such as lamb's wool bonnet, polishing felt or sponge (accessories).

Select a low stroke rate (setting 1 – 2) for polishing in order to avoid excessive heating of the surface.

Apply the polish onto a somewhat smaller surface than you intend to polish. Work the polishing agent in with a suitable polishing tool applying it crosswise or with circular motion and moderate pressure.

Do not allow the polishing agent to dry out on the surface, otherwise the surface can become damaged. Do not subject the surface to be polished to direct sunlight.

Clean the polishing accessories regularly to ensure good polishing results. Wash out polishing accessories with a mild detergent and warm water; do not use paint thinner.

Maintenance and Service**Maintenance and Cleaning**

- ▶ **Before any work on the machine itself, pull the mains plug.**
- ▶ **For safe and proper working, always keep the machine and ventilation slots clean.**

If the machine should fail despite the care taken in manufacturing and testing procedures, repair should be carried out by an after-sales service centre for Bosch power tools.

In all correspondence and spare parts order, please always include the 10-digit article number given on the type plate of the machine.

After-sales Service and Customer Assistance

Our after-sales service responds to your questions concerning maintenance and repair of your product as well as spare parts. Exploded views and information on spare parts can also be found under:

www.bosch-pt.com

Our customer service representatives can answer your questions concerning possible applications and adjustment of products and accessories.

Great Britain

Robert Bosch Ltd. (B.S.C.)
P.O. Box 98
Broadwater Park
North Orbital Road
Denham
Uxbridge
UB 9 5HJ
Tel. Service: +44 (0844) 736 0109
Fax: +44 (0844) 736 0146
E-Mail: boschservicecentre@bosch.com

Ireland

Origo Ltd.
Unit 23 Magna Drive
Magna Business Park
City West
Dublin 24
Tel. Service: +353 (01) 4 66 67 00
Fax: +353 (01) 4 66 68 88

Australia, New Zealand and Pacific Islands

Robert Bosch Australia Pty. Ltd.
Power Tools
Locked Bag 66
Clayton South VIC 3169
Customer Contact Center
Inside Australia:
Phone: +61 (01300) 307 044
Fax: +61 (01300) 307 045
Inside New Zealand:
Phone: +64 (0800) 543 353
Fax: +64 (0800) 428 570
Outside AU and NZ:
Phone: +61 (03) 9541 5555
www.bosch.com.au

Republic of South Africa

Customer service
Hotline: +27 (011) 6 51 96 00

Gauteng – BSC Service Centre

35 Roper Street, New Centre
Johannesburg
Tel.: +27 (011) 4 93 93 75
Fax: +27 (011) 4 93 01 26
E-Mail: bsctools@icon.co.za

KZN – BSC Service Centre

Unit E, Almar Centre
143 Crompton Street
Pinetown
Tel.: +27 (031) 7 01 21 20
Fax: +27 (031) 7 01 24 46
E-Mail: bsc.dur@za.bosch.com

Western Cape – BSC Service Centre

Democracy Way, Prosperity Park
Milnerton
Tel.: +27 (021) 5 51 25 77
Fax: +27 (021) 5 51 32 23
E-Mail: bsc@zsd.co.za

18 | English

Bosch Headquarters

Midrand, Gauteng
 Tel.: +27 (011) 6 51 96 00
 Fax: +27 (011) 6 51 98 80
 E-Mail: rbsa-hq.pts@za.bosch.com

People's Republic of China**China Mainland**

Bosch Power Tools (China) Co., Ltd.
 567, Bin Kang Road
 Bin Jiang District 310052
 Hangzhou, P. R. China
 Service Hotline: 400 826 8484
 Fax: +86 571 8777 4502
 E-Mail: contact.ptcn@cn.bosch.com
 www.bosch-pt.com.cn

HK and Macau Special Administrative Regions

Robert Bosch Hong Kong Co. Ltd.
 21st Floor, 625 King's Road
 North Point, Hong Kong
 Customer Service Hotline: +852 (21) 02 02 35
 Fax: +852 (25) 90 97 62
 E-Mail: info@hk.bosch.com
 www.bosch-pt.com.hk

Indonesia

PT. Multi Tehaka
 Kawasan Industri Pulogadung
 Jalan Rawa Gelam III No. 2
 Jakarta 13930
 Indonesia
 Tel.: +62 (21) 46 83 25 22
 Fax: +62 (21) 46 82 86 45/68 23
 E-Mail: sales@multitehaka.co.id
 www.multitehaka.co.id

Philippines

Robert Bosch, Inc.
 28th Floor Fort Legend Towers,
 3rd Avenue corner 31st Street,
 Fort Bonifacio Global City,
 1634 Taguig City, Philippines
 Tel.: +63 (2) 870 3871
 Fax: +63 (2) 870 3870
 matheus.contiero@ph.bosch.com
 www.bosch-pt.com.ph
 Bosch Service Center:
 9725-27 Kamagong Street
 San Antonio Village
 Makati City, Philippines
 Tel.: +63 (2) 899 9091
 Fax: +63 (2) 897 6432
 rosalia.dagdagan@ph.bosch.com

Malaysia

Robert Bosch (S.E.A.) Pte. Ltd.
 No. 8A, Jalan 13/6
 G.P.O. Box 10818
 46200 Petaling Jaya
 Selangor, Malaysia
 Tel.: +60 (3) 7966 3194
 Fax: +60 (3) 7958 3838

cheehoe.on@my.bosch.com
 Toll-Free: 1800 880 188
 www.bosch-pt.com.my

Thailand

Robert Bosch Ltd.
 Liberty Square Building
 No. 287, 11 Floor
 Silom Road, Bangrak
 Bangkok 10500
 Tel.: +66 (2) 6 31 18 79 – 18 88 (10 lines)
 Fax: +66 (2) 2 38 47 83
 Robert Bosch Ltd., P. O. Box 2054
 Bangkok 10501, Thailand

Bosch Service – Training Centre
 2869-2869/1 Soi Ban Kluay
 Rama IV Road (near old Paknam Railway)
 Prakanong District
 10110 Bangkok
 Thailand
 Tel.: +66 (2) 6 71 78 00 – 4
 Fax: +66 (2) 2 49 42 96
 Fax: +66 (2) 2 49 52 99

Singapore

Robert Bosch (SEA) Pte. Ltd.
 11 Bishan Street 21
 Singapore 573943
 Tel.: +65 6571 2772
 Fax: +65 6350 5315
 leongheng.leow@sg.bosch.com
 Toll-Free: 1800 333 8333
 www.bosch-pt.com.sg

Vietnam

Robert Bosch Vietnam Co. Ltd
 10/F, 194 Golden Building
 473 Dien Bien Phu Street
 Ward 25, Binh Thanh District
 84 Ho Chi Minh City
 Vietnam
 Tel.: +84 (8) 6258 3690 ext. 413
 Fax: +84 (8) 6258 3692
 hieu.lagia@vn.bosch.com
 www.bosch-pt.com

Disposal

The machine, accessories and packaging should be sorted for environmental-friendly recycling.

Do not dispose of power tools into household waste!

Only for EC countries:

According to the European Guideline 2002/96/EC for Waste Electrical and Electronic Equipment and its implementation into national right, power tools that are no longer usable must be collected separately and disposed of in an environmentally correct manner.

Subject to change without notice.