

# Operating instructions

Combined fridge-freezer

GB



021211 **7084698 - 02**

CN(es/esf/sl) ... 3

# LIEBHERR

# Appliance at a glance

## Contents

<b>1 Appliance at a glance</b> .....	<b>2</b>
1.1 Description of appliance and equipment.....	2
1.2 Range of appliance use.....	2
1.3 Conformity.....	3
1.4 External dimensions of the appliance.....	3
1.5 Saving energy.....	3
<b>2 General safety information</b> .....	<b>3</b>
<b>3 Controls and displays</b> .....	<b>4</b>
3.1 Operating and control elements.....	4
3.2 Temperature display.....	4
<b>4 Putting into operation</b> .....	<b>4</b>
4.1 Transporting the appliance.....	4
4.2 Installing the appliance.....	4
4.3 Changing over the door hinges.....	5
4.4 Insertion into a row of kitchen units.....	7
4.5 Disposing of packaging.....	7
4.6 Connecting the appliance.....	7
4.7 Switching on the appliance.....	7
<b>5 Control</b> .....	<b>7</b>
5.1 Door alarm.....	7
5.2 Temperature alarm.....	8
5.3 Refrigerator compartment.....	8
5.4 Freezer compartment.....	9
<b>6 Maintenance</b> .....	<b>11</b>
6.1 Defrosting with NoFrost.....	11
6.2 Cleaning the appliance.....	11
6.3 Cleaning the IceMaker.....	12
6.4 Changing the interior light with bulb.....	12
6.5 Customer service.....	12
<b>7 Malfunction</b> .....	<b>13</b>
<b>8 Decommissioning</b> .....	<b>13</b>
8.1 Switching off the appliance.....	13
8.2 Taking the appliance out of service.....	14
<b>9 Disposing of the appliance</b> .....	<b>14</b>

The manufacturer works constantly on the further development of all the types and models. Therefore please understand that we have to reserve the right to make design, equipment and technical modifications.

To get to know all the benefits of your new appliance, please read the information contained in these instructions carefully.

The instructions apply to several models. Differences may occur. Text relating only to specific appliances is marked with an asterisk (\*).

Instructions for action are marked with a ►, the results of action are marked with a ▷.

## 1 Appliance at a glance

### 1.1 Description of appliance and equipment

#### Note

- Place food inside the appliance as shown in the diagram. This allows the appliance to save energy during operation.
- Shelves, drawers and baskets are arranged for optimum energy efficiency on delivery.

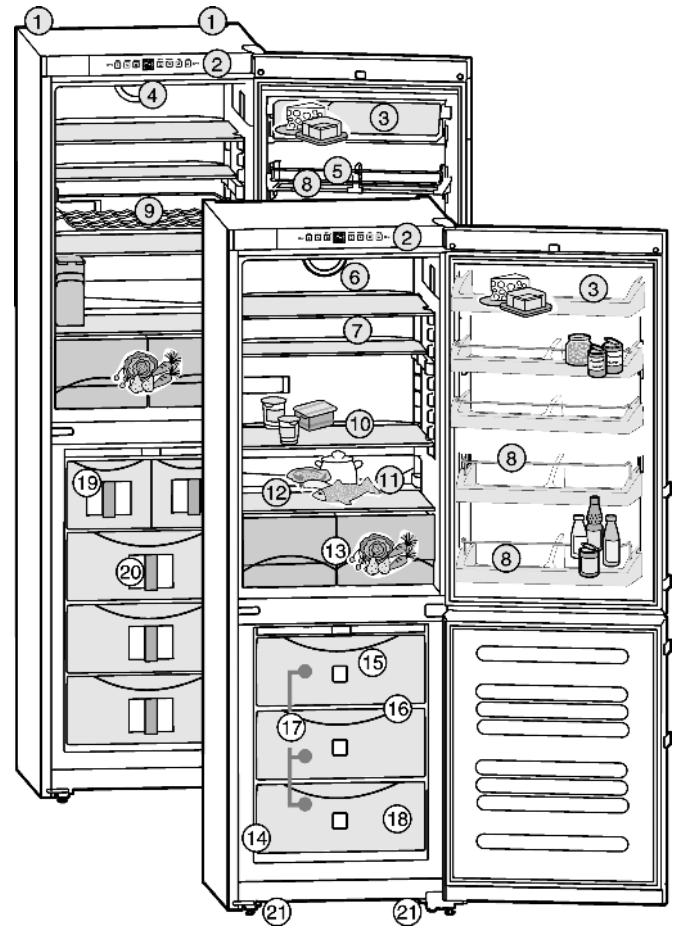

Fig. 1

- |                                    |   |
|------------------------------------|---|
| (1) Transport grips at back        | (12) Coldest zone   |
| (2) Operating and control elements | (13) Vegetable bin  |
| (3) Butter and cheese compartment  | (14) Type plate   |
| (4) Fan*                           | (15) Cold storage accumulators*   |
| (5) Door rack                      | (16) VarioSpace   |
| (6) Interior light                 | (17) Freezer drawer   |
| (7) Shelf, sectioned *             | (18) Ice-cube tray  |
| (8) Bottle holder                  | (19) IceMaker*  |
| (9) Bottle shelf*                  | (20) Information system*  |
| (10) Shelf, relocatable            | (21) Adjustable feet, transport grips at front, transport castors at back |
| (11) Drain hole                    |   |

### 1.2 Range of appliance use

The appliance is suitable solely for cooling food in a domestic environment or similar. This includes use in, for example

- in staff kitchenettes, bed and breakfast establishments,
- by guests in country homes, hotels, motels and other forms of accommodation,
- in catering and similar services in the wholesale trade

Use the appliance solely as is customary within a domestic environment. All other types of use are inadmissible. The appliance is not suitable for storing and cooling medicines, blood plasma, laboratory preparations or similar substances and products covered by the 2007/47/EC Medical Devices Directive. Misuse of the appliance can result in the stored products suffering harm or perishing. Furthermore, the appliance is not suitable for operation in potentially explosive atmospheres.

The appliance is set to operate within specific ambient temperature limits according to its climate rating. The correct climate rating for your appliance is indicated on the type plate.

## Note

- Compliance with the ambient temperatures indicated is required, otherwise the cooling performance is reduced.

Climate rating	for ambient temperatures of
SN	10 °C to 32 °C
N	16 °C to 32 °C
ST	16 °C to 38 °C
T	16 °C to 43 °C

## 1.3 Conformity

The refrigerant circuit is tested for leakage. The appliance complies with the relevant safety regulations and EC Directives 2006/95/EC, 2004/108/EC, 2009/125/EC and 2010/30/EU.

## 1.4 External dimensions of the appliance

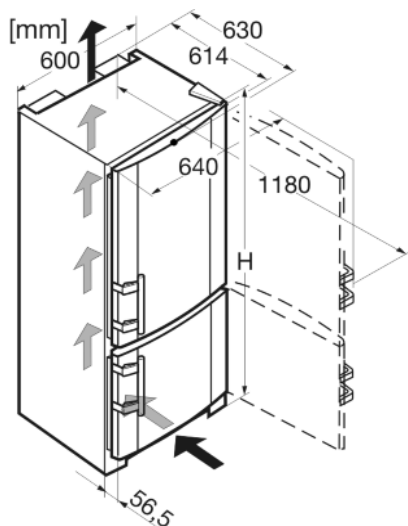

Fig. 2

Model	Height of appliance H (mm)
CN(es/sl) 35.., CNP(esf/sl) 35..	1817
CN 39.., CNP(esf) 39..	2011
CN(es/esf/sl) 40.., CNP(esf) 40..	2011

## 1.5 Saving energy

- Always ensure good ventilation. Do not cover ventilation openings or grille.
- Always keep fan louvres clear.
- Do not place appliance in areas of direct sunlight or next to a stove, heater or similar object.
- The energy consumption depends on the installation conditions, e.g. the ambient temperature (see 1.2) .
- Keep the time the appliance is open to a minimum.
- The lower the temperature setting, the higher the power consumption.
- Store food logically. (see Appliance at a glance).
- Ensure that all food is well packed and covered for storage. This will prevent frost from forming.
- Remove food as needed in order that it does not warm too much.
- First cool warm food to room temperature before storing it .

- Defrost frozen food in the refrigerator.
- Empty and switch off refrigerating unit for longer vacation periods.

Accumulated dust increases the energy consumption:

- Once a year, dust the refrigerating unit together with the metal grille of the heat exchanger at the back of the appliance.

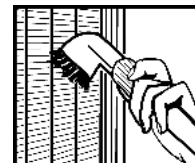

GB

## 2 General safety information

### Danger for the user:

- This appliance is not designed for persons (including children) with physical, sensory or mental impairment or persons not having sufficient experience and knowledge, unless they are instructed in the use of the appliance and are initially supervised by a person responsible for their safety. Keep children under supervision to ensure they do not play with the appliance.
- In case of a fault, pull out the mains plug (not by pulling the connecting cable) or switch off the fuse.
- Have any repairs to or intervention in the appliance, and any change of the mains power cable, carried out by the customer service only or by other specialised personnel trained for the purpose.
- When disconnecting the appliance from the supply, always take hold of the plug. Do not pull the cable.
- Install and connect the appliance only as instructed.
- Please keep these instructions in a safe place and pass them on to any subsequent owners.
- All repairs to and intervention in the IceMaker may be carried out only by service personnel or by other skilled personnel trained for the purpose.\*
- Special-purpose lamps (incandescent lamps, LEDs, fluorescent tubes) in the appliance serve to illuminate the appliance interior and are not suited for room illumination.

### Fire hazard:

- The refrigerant R 600a is environmentally friendly but flammable. Escaping refrigerant may ignite.
  - Do not damage the refrigerant circuit pipes.
  - Do not allow naked flames or ignition sources to enter the appliance.
  - Do not use any electrical appliances in the interior (e.g. steam cleaners, heaters, ice cream maker etc.).
  - If refrigerant escapes: eliminate naked flames or sources of ignition from the vicinity. Pull out the power plug. Ventilate the area well. Notify customer service.
- Do not store explosives or sprays using combustible propellants such as butane, propane, pentane, etc. in the appliance. To identify these spray cans, look for the list of contents printed on the can, or a flame symbol. Gases possibly escaping may ignite due to electrical components.
- Keep burning candles, lamps and other items with naked flames away from the appliance so that they do not set the appliance on fire.
- Always store high-percentage alcohol in tightly sealed, upright containers. Alcohol possibly escaping may ignite due to electrical components.

### Danger of tipping and falling:

- Do not misuse the plinth, drawers, doors etc. as a step or for support. This applies particularly to children.

### Danger of food poisoning:

- Do not consume food which has been stored too long.



### Danger of frostbite, numbness and pain:

- Avoid lasting skin contact with cold surfaces or refrigerated/frozen food or take protective steps, e.g. wear gloves. Do

# Controls and displays

not consume ice cream, water ice or ice cubes immediately and do not consume them too cold.

Please observe the specific information in the other sections:

	DANGER	identifies a situation involving direct danger which, if not obviated, may result in death or severe bodily injury.
	WARNING	identifies a dangerous situation which, if not obviated, may result in death or severe bodily injury.
	CAUTION	identifies a dangerous situation which, if not obviated, may result in minor or medium bodily injury.
	NOTICE	identifies a dangerous situation which, if not obviated, may result in damage to property.
	Note	identifies useful information and tips.

## 3 Controls and displays

### 3.1 Operating and control elements

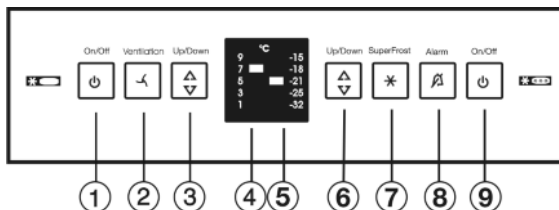

Fig. 3

- |  |   |
|--|---|
| (1) On/Off button, refrigerator compartment      | (6) Setting button, freezer compartment |
| (2) Fan button                                   | (7) SuperFrost button                   |
| (3) Setting button, refrigerator compartment     | (8) Alarm button                        |
| (4) Refrigerator compartment temperature display | (9) On/Off button, freezer compartment  |
| (5) Freezer compartment temperature display      |   |

### 3.2 Temperature display

The following are displayed in normal operation:

- the set freezing temperature
- the set cooling temperature

The freezer compartment temperature display flashes:

- the temperature setting is being changed
- after switch-on the temperature is not yet cold enough
- the temperature has risen several degrees

## 4 Putting into operation

### 4.1 Transporting the appliance



#### CAUTION

Risk of injury and danger of damage as a result of incorrect transport!

- ▶ Transport the appliance in a packed condition.
- ▶ Transport the appliance upright.
- ▶ Do not transport the appliance without assistance.

### 4.2 Installing the appliance



#### WARNING

Fire hazard due to dampness!

If live parts or the mains lead become damp this may cause short circuits.

- ▶ The appliance is designed for use in enclosed areas. Do not operate the appliance outdoors or in areas where it is exposed to splash water or damp conditions.



#### WARNING

Risk of fire due to short circuit!

If the mains cable/connector of the appliance or of another appliance touch the rear of the appliance, the mains cable/connector may be damaged by the appliance vibrations, leading to a short circuit.

- ▶ Stand the appliance so that it is not touched by connectors or main cables.
- ▶ Do not plug the appliance or any others into sockets located near the rear of the appliance.



#### WARNING

Fire hazard due to refrigerant!

The refrigerant R 600a is environmentally friendly but flammable. Escaping refrigerant may ignite.

- ▶ Do not damage the piping of the refrigeration circuit.



#### WARNING

Fire hazard and danger of damage!

- ▶ Do not place appliances emitting heat e.g. microwaves, toasters etc. on the appliance!



#### WARNING

Blocked ventilation openings pose a risk of fire and damage!

- ▶ Always keep the ventilation openings clear. Always ensure that the appliance is properly ventilated!

#### NOTICE

Risk of damage due to condensate!

- ▶ Do not install the appliance directly alongside a further refrigerator/freezer.

- In the event that the appliance is damaged, contact the supplier immediately before connecting to the mains.
- The floor at the site must be flat and level.
- Do not install the appliance in a location where it is exposed to direct radiation of the sun, next to a cooker, heater and similar.

- ❑ Always stand the appliance backed directly to the wall using the enclosed wall spacers (see below).
- ❑ The appliance may be moved only when it is empty.
- ❑ Do not install the appliance without assistance.
- ❑ Standard EN 378 specifies that the room in which you install your appliance must have a volume of 1 m<sup>2</sup> per 8 g of R 600a refrigerant used in the appliance. If the room in which the appliance is installed is too small, a flammable gas-air mixture may form in the event of a leakage in the refrigeration circuit. The quantity of refrigerant used in your appliance is indicated on the type plate on the inside of the appliance.
- ▶ Detach the connecting cable from the rear of the appliance, removing the cable holder at the same time because otherwise there will be vibratory noise!
- ▶ Remove the protective film from the outside of the appliance.\*

## NOTICE

The **stainless steel doors** are finished with a high quality surface coating and must not be treated with the enclosed care product,



as otherwise the surface coating will be damaged.

- ▶ Please only use a soft clean cloth to wipe the **coated door surfaces**.
- ▶ Only use a stainless steel care product on the **stainless steel side walls**, applying it evenly in the direction of polishing. Subsequent cleaning will then be easier.
- ▶ Use only a soft clean cloth to wipe **side walls** and **door surfaces** with a paint finish.

- ▶ Remove the protective film from the decorative trims and drawer fronts.\*
- ▶ Remove all transit supports.
- ▶ Dispose of packaging material (see 4.5) .
- ▶ Align the appliance so that it stands firmly and on a level by applying the accompanying spanner to the adjustable-height feet (A) and using a spirit level.
- ▶ Then support the door: Extend the adjustable foot at the turn hinge (B) until it rests on the floor and then make a further 90° turn.

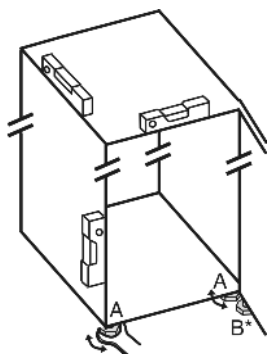

## Note

- ▶ Clean the appliance (see 6.2) .

If the appliance is installed in a very damp environment, condensate may form on the outside of the appliance.

- ▶ Always see to good ventilation at the installation site.

## 4.3 Changing over the door hinges

You can change over the door hinges if necessary.

Ensure that the following tools are to hand:

- ❑ Torx® 25
- ❑ Torx® 15
- ❑ Screwdriver
- ❑ Cordless screwdriver, if necessary
- ❑ Second person for fitting work, if needed

### 4.3.1 Detaching the upper door

#### Note

- ▶ Remove any food from the door racks before removing the door, so that no food falls out.

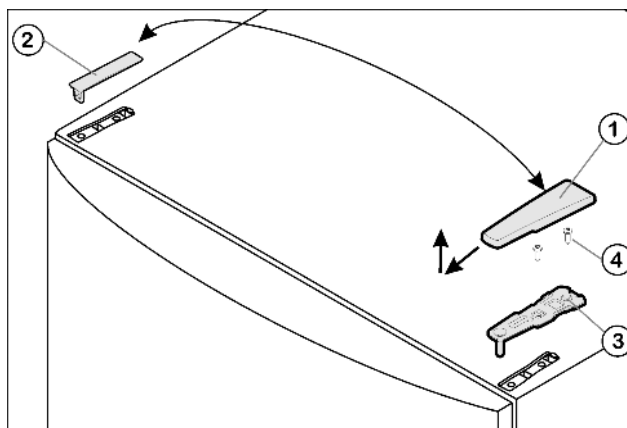

Fig. 4

- ▶ Close the upper door.
- ▶ Pull off the cover Fig. 4 (1) forwards and upwards.
- ▶ Lift off the cover Fig. 4 (2).



#### CAUTION

Risk of injury if the door tips!

- ▶ Take good hold of the door.
- ▶ Set down the door carefully.

- ▶ Unscrew the upper turn hinge Fig. 4 (3)(2x Torx® 25) Fig. 4 (4) and lift it off.
- ▶ Lift up the upper door and set it aside.

### 4.3.2 Detaching the lower door

- ▶ Close the lower door.
- ▶ Draw the middle bearing pin Fig. 5 (11) out of the turn hinge and lower door.
- ▶ Remove the plastic cap Fig. 5 (10).



#### CAUTION

Risk of injury if the door tips!

- ▶ Take good hold of the door.
- ▶ Set down the door carefully.

- ▶ Open the lower door.
- ▶ Unscrew the middle turn hinge (2x Torx® 25). Fig. 5 (13)
- ▶ Lift up the door and set it aside.

### 4.3.3 Transferring the middle bearing elements

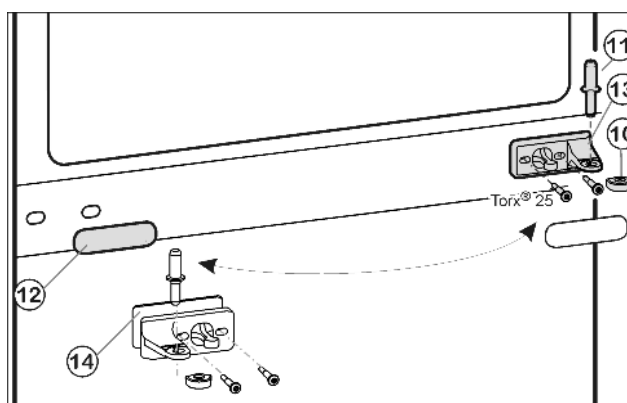

Fig. 5

# Putting into operation

- ▶ Carefully detach the cover panel *Fig. 5 (12)*.
- ▶ Turn the middle turn hinge *Fig. 5 (13)* with the washer *Fig. 5 (14)* through 180° and screw it firmly into place on the new hinge side (**with 4 Nm**).
- ▶ Turn the cover panel *Fig. 5 (12)* through 180° and snap it into place again on the new handle side.

## 4.3.4 Transferring the lower bearing elements

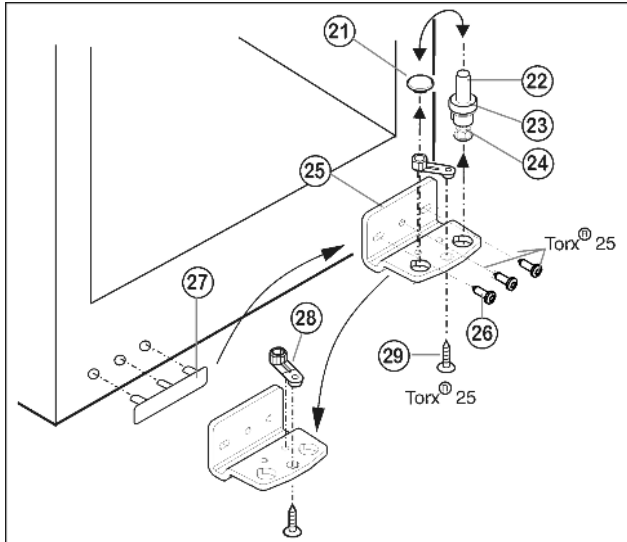

Fig. 6

- ▶ Lift out the bearing pin *Fig. 6 (22)* together with washer *Fig. 6 (23)* and foot *Fig. 6 (24)*.
- ▶ Lift off the stopper *Fig. 6 (21)*.
- ▶ Unscrew *Fig. 6 (26)* the turn hinge *Fig. 6 (25)*.
- ▶ Unscrew *Fig. 6 (29)* the bearing element *Fig. 6 (28)*, transfer it to the opposite location hole of the turn hinge and screw it firmly into place.
- ▶ Carefully lift off the cover on the handle side *Fig. 6 (27)* and transfer it to the opposite side.
- ▶ Screw the turn hinge *Fig. 6 (25)* firmly into place on the new hinge side, possibly using a cordless screwdriver (**with 4 Nm**).
- ▶ Re-insert the stopper *Fig. 6 (21)* into the other hole.
- ▶ Re-insert the bearing pin *Fig. 6 (22)* together with washer and foot. In so doing, pay attention that the locating lug points backwards

## 4.3.5 Transferring the handles

On both the upper and lower door:

- ▶ Transfer the spring clamp *Fig. 7 (31)*: Depress the latch nose and pull the spring clamp off over it.
- ▶ Slide the spring clamp into place on the new hinge side until it clicks into place.

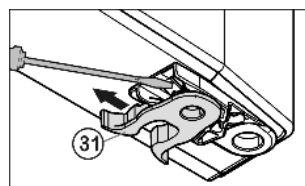

Fig. 7

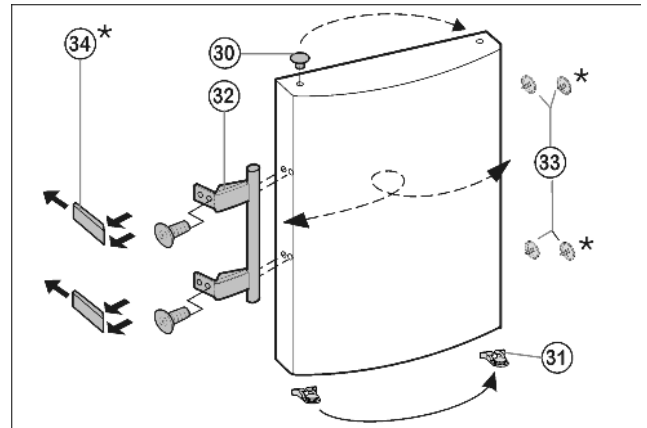

Fig. 8

- ▶ Lift the stopper *Fig. 8 (30)* out of the door bearing bush and transfer it.
- ▶ Detach door handle *Fig. 8 (32)*, stopper *Fig. 8 (33)* and pressure plates *Fig. 8 (34)* and transfer to the opposite side.
- ▶ When fitting the pressure plates on the opposite side, make sure they snap properly into place\*

## 4.3.6 Fitting the lower door

- ▶ Place the lower door from above onto the lower bearing pin *Fig. 6 (22)*.
- ▶ Close the door.
- ▶ Place the plastic cap *Fig. 5 (10)* back onto the middle turn hinge *Fig. 5 (13)*.
- ▶ Place the middle bearing pin *Fig. 5 (11)* in the lower door, on the new hinge side, through the middle turn hinge *Fig. 5 (13)*.

## 4.3.7 Fitting the upper door

- ▶ Place the upper door on the middle bearing pin *Fig. 5 (11)*.
- ▶ Insert the upper turn hinge *Fig. 4 (3)* in the door on the new hinge side.
- ▶ Screw the upper turn hinge **firmly** into place (**with 4 Nm**) (2x Torx® 25) *Fig. 4 (4)*. Possibly make preliminary holes with a bradawl or use a cordless screwdriver.
- ▶ Apply the cover *Fig. 4 (1)* and cover *Fig. 4 (2)* to the opposite side from the outside and snap them into place.

## 4.3.8 Aligning the doors

- ▶ If necessary, align the doors to the appliance housing by way of the two oblong holes in the bottom turn hinge *Fig. 6 (25)* and middle turn hinge *Fig. 5 (13)*. To do so, unscrew the middle screw in the bottom turn hinge *Fig. 6 (25)*.



### WARNING

Risk of injury due to the door dropping out!  
If the bearing parts are not screwed into place firmly enough, the door may drop out. This may lead to severe injuries. What is more, the door may not close and therefore the appliance may fail to cool properly.

- ▶ Screw the turn hinges firmly into place with 4 Nm.
- ▶ Check all of the screws and retighten if necessary.

## 4.4 Insertion into a row of kitchen units

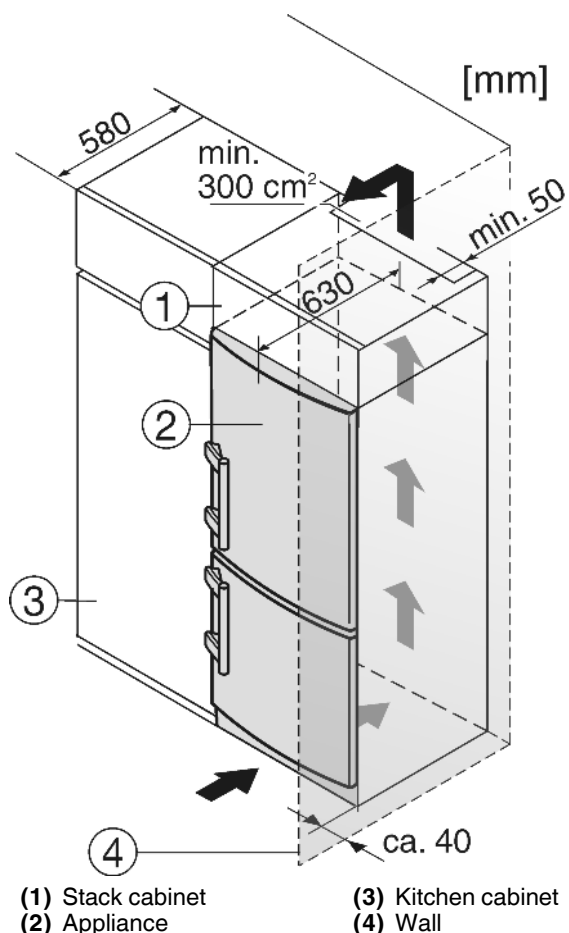

Fig. 9

The appliance can be inserted into a row of kitchen units. To match the appliance Fig. 9 (2) to the height of the row of units, a suitable stack cabinet Fig. 9 (1) can be fitted above the appliance.

When inserting the appliance into a row of kitchen units (max. depth 580 mm), the appliance can be installed directly next to the kitchen unit Fig. 9 (3). The appliance door projects relative to the front of the kitchen unit by 34 mm at the side and by 50 mm in the middle of the appliance. It can be opened and closed perfectly as a result.

Important for the ventilation:

- At the back of the stack cabinet there has to be a ventilation duct of at least 50 mm depth throughout the width of the stack cabinet.
- The ventilation space under the ceiling has to be at least 300 cm<sup>2</sup>.

If the appliance is installed with the hinges next to a wall Fig. 9 (4), the distance between appliance and wall has to be at least 40 mm. This corresponds to the projection of the handle when the door is open.

## 4.5 Disposing of packaging



### WARNING

Danger of suffocation due to packing material and plastic film!  
▶ Do not allow children to play with packing material.

The packaging is made of recyclable materials:

- corrugated board/cardboard
- expanded polystyrene parts
- polythene bags and sheets
- polypropylene straps



- nailed wooden frame with polyethylene panel\*
- ▶ Take the packaging material to an official collecting point.

## 4.6 Connecting the appliance

### NOTICE

Risk of damage to the electronic control system!

- ▶ Do not use stand-alone inverters (conversion of d.c. to a.c./three-phase) or energy saving plugs.



### WARNING

Fire and overheating hazard!

- ▶ Do not use extension cables or multiple socket outlets.

The type of current (alternating current) and voltage at the installation site have to conform with the data on the type plate (see Appliance at a glance).

Connect the appliance only with a properly installed socket outlet with earthing contact. The socket outlet must be fused with 10 A or higher.



It must be easily accessible so that the appliance can be quickly disconnected from the supply in an emergency. It must be outside the area of the rear of the appliance.

- ▶ Check the electrical connection.
- ▶ Plug in the power plug.

## 4.7 Switching on the appliance

### Note

- ▶ To switch on the entire appliance it is necessary only to switch on the freezer compartment. In so doing, the refrigerator compartment is automatically switched on as well.

Put the appliance into operation about 2 hours before first loading food to be frozen.

### 4.7.1 Switching on the freezer compartment

- ▶ Press On/Off button, freezer compartment Fig. 3 (9).
- ▷ The appliance is switched on. The refrigerator compartment temperature display indicates the set temperature. The freezer compartment temperature display and the alarm button flash until the temperature is sufficiently low.

### 4.7.2 Switching on the refrigerator compartment

### Note

- ▶ When the refrigerator compartment is switched on, the freezer compartment is automatically switched on as well.

- ▶ Press On/Off button, refrigerator compartment Fig. 3 (1).
- ▷ The interior light is on when the door is open.
- ▷ The temperature display shines. Refrigerator compartment and freezer compartment are switched on.

## 5 Control

### 5.1 Door alarm

For refrigerator and freezer compartment

If the door is open longer than 60 s, the audible alarm sounds.

The audible alarm is automatically silenced when the door is closed.

# Control

## 5.1.1 Muting the door alarm

The audible alarm can be muted when the door is open. The sound switch-off function is active as long as the door is left open.

- ▶ Press alarm button *Fig. 3 (8)*.
- ▷ The door alarm is silenced.

## 5.2 Temperature alarm

The audible alarm sounds if the freezer temperature is not cold enough.

The alarm button flashes at the same time.

The cause of the temperature being too high may be:

- warm fresh food was placed inside
- too much warm ambient air flowed in when rearranging and removing food
- power failure for some time
- the appliance is faulty

The audible alarm is automatically silenced, the alarm button *Fig. 3 (8)* goes out and the temperature display stops flashing when the temperature is sufficiently cold again.

If the alarm status persists: (see Malfunction).

### Note

Food may be spoilt if the temperature is not cold enough.

- ▶ Check the quality of the food. Do not consume spoiled food.

## 5.2.1 Muting the temperature alarm

The audible alarm can be muted. When the temperature is sufficiently cold again, the alarm function is active again.

- ▶ Press alarm button *Fig. 3 (8)*.
- ▷ The audible alarm is silenced.

## 5.3 Refrigerator compartment

The natural circulation of air in the refrigerator compartment results in zones differing in temperature. It is coldest directly above the vegetable drawers and at the rear wall. It is warmest at the top front of the compartment and in the door.

### 5.3.1 Food refrigeration

#### Note

The energy consumption increases and the cooling performance decreases if the ventilation is inadequate.

- ▶ Always keep the air slits of the fan free.

- ▶ Store perishable food such as ready-to-serve dishes, meat products and sausages in the coldest zone. Place butter and preserves in the upper area and in the door (see Appliance at a glance).
- ▶ Use recyclable plastic, metal, aluminium and glass containers and cling film for wrapping.
- ▶ Use the front area of the refrigerator compartment floor only for briefly putting down cooled products, e.g. when rearranging and sorting. However do not leave cooled products there otherwise they may be pushed back or tipped over when the door is closed.
- ▶ Do not store food too close together to enable good air circulation.
- ▶ To safeguard bottles from tipping over: move the bottle holder.

### 5.3.2 Setting the temperature

The temperature depends on the following factors:

- the door opening frequency
- the room temperature at the site where the appliance is installed

- the type, temperature and quantity of frozen food

Temperature setting to be recommended: 5 °C

The temperature can be changed continuously. Once the 1 °C setting is reached, it starts again with 9 °C.

- ▶ To access temperature adjustment: press the setting button, refrigerator compartment *Fig. 3 (3)* once.
- ▷ The LED of the current temperature flashes in the temperature display.
- ▶ Press the setting button, refrigerator compartment *Fig. 3 (3)* the number of times needed until the required temperature shines in the LED display.

### Note

- ▶ Long pressing of the setting button sets a slightly colder value within a small temperature range (e.g.: between 5 °C and 7 °C). The LED of the next lower temperature range then shines in the temperature display.

## 5.3.3 Fan

With the fan you can rapidly cool large quantities of fresh food or achieve a relatively even distribution of temperature across all the storage levels.

The forced-air cooling is to be recommended:

- at high room temperature (above 33 °C)
- at high humidity

The forced-air cooling uses slightly more energy. To save energy, the fan switches off automatically when the door is open.

### Switching on the fan

- ▶ Briefly press the fan button *Fig. 3 (2)*.
- ▷ The fan button shines.
- ▷ The fan is active. It switches on automatically when the compressor runs.

### To switch off the fan

- ▶ Briefly press the fan button *Fig. 3 (2)*.
- ▷ The fan button goes out.
- ▷ The fan is switched off.

## 5.3.4 Relocating the shelves

The shelves have stops preventing them from being unintentionally pulled out.

- ▶ Lift the shelf and draw it out forwards.
- ▶ Insert shelf with the raised edge pointing upwards at the back.
- ▷ The food does not freeze onto the rear wall.

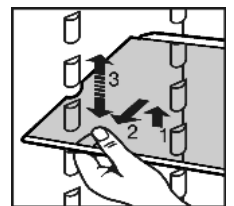

## 5.3.5 Using the sectioned shelf\*

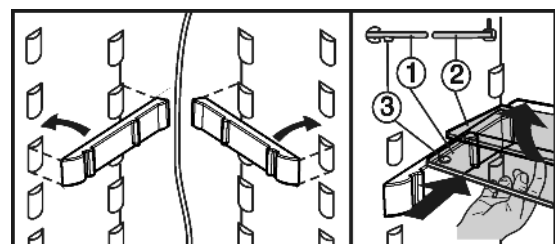

- ▶ The glass shelf with stop face (2) has to be at the back.

### 5.3.6 Moving the storage rack

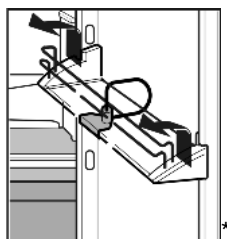

- ▶ Remove storage rack according to illustration.

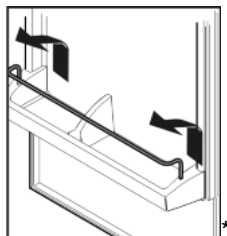

The boxes can be removed and placed on the table as a single unit.\*

Only one box or both boxes can be used. If particularly tall bottles are to be stored, attach only the wide box above the bottle rack.\*

Three small boxes are available through the customer service as optional equipment instead of one wide and one small box.\*

- ▶ Re-positioning the boxes: Lift them for removal and re-position them as required.\*

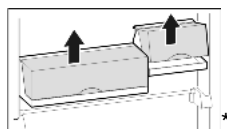

- ▶ To detach lid: Open 90° and raise to disengage.\*

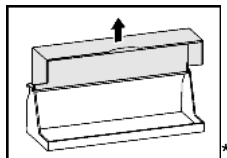

### 5.3.7 Removing the bottle holder\*

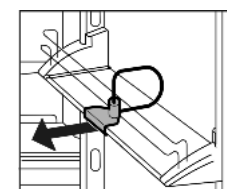

- ▶ Always take hold of the bottle holder on the plastic part.

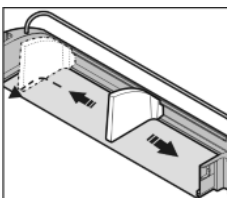

## 5.4 Freezer compartment

You can store frozen food, make ice cubes and freeze fresh food in the freezer compartment.

### 5.4.1 Freezing food

The rating plate indicates the maximum quantity of fresh food you can freeze within 24 hours (see Appliance at a glance) under "Freezing capacity ... kg/24h".

The maximum load of frozen food for the drawers is 25 kg each and for the shelves 35 kg each.



### CAUTION

Risk of injury due to broken glass!

Bottles and cans containing drinks may burst when being frozen. This applies particularly to sparkling drinks.

- ▶ Do not freeze bottles and cans containing drinks!

In order that the food is rapidly frozen through to the core, do not exceed the following quantities per pack:

- Fruit, vegetables up to 1 kg
- Meat up to 2.5 kg
- ▶ Pack the food in portions in freezer bags, reusable plastic, metal or aluminium containers.

### 5.4.2 Thawing food

- in the refrigerator compartment
- at room temperature
- in a microwave oven
- in a conventional or fan oven
- ▶ Food once thawed should be re-frozen only in exceptional cases.

### 5.4.3 Setting the temperature

Temperature setting to be recommended: -18 °C

The temperature can be changed continuously. Once the -32 °C setting is reached, it starts again with -15 °C.

- ▶ To access temperature adjustment: press setting button, freezer compartment *Fig. 3 (6)* once.
- ▷ The LED of the current temperature flashes in the temperature display of the freezer compartment.
- ▶ Press the setting button, freezer compartment *Fig. 3 (6)* the number of times needed until the required temperature shines in the LED display.

### Note

- ▶ Long pressing of the setting button sets a slightly colder value within a small temperature range (e.g.: between -15 °C and -18 °C). The LED of the next lower temperature range then shines in the temperature display.

### 5.4.4 SuperFrost

With this function you can freeze fresh food quickly through to the core. The appliance operates with maximum refrigeration. The noise of the refrigeration unit may be temporarily louder as a result.

The maximum amount of fresh food which can be frozen in 24 h is indicated on the type plate under "freezing capacity ... kg/24h". This amount varies according to the model and climate rating.

You have to activate SuperFrost in good time, depending on how much fresh food is to be frozen: about 6 hours before placing the food inside in case of small amounts and about 24 hours in advance in case of the maximum amount of food to be frozen.

Wrap produce and spread it out as far as possible. Do not allow produce to be frozen to touch produce that is already frozen to prevent the latter thawing.

You do not have to activate SuperFrost in the following cases:

- when placing frozen food in the freezer

### Freezing with SuperFrost

- ▶ Briefly press the SuperFrost button *Fig. 3 (7)*.
- ▷ The SuperFrost button shines.
- ▷ The freezer temperature drops, the appliance operates with the maximum refrigerating capacity.
- In case of a small amount of food to be frozen:
  - ▶ wait approx. 6 h.
  - ▶ Place wrapped produce in the top drawers.

# Control

In case of the maximum amount of food to be frozen (see type plate):

- ▶ wait about 24 h.
- ▶ Remove top drawers and place produce directly on the top shelves.
- ▷ SuperFrost is automatically deactivated after about 65 h.
- ▷ The SuperFrost button extinguishes once freezing is completed.
- ▶ Place produce in the drawers and push the latter back in again.
- ▷ The appliance continues to operate in the energy-saving, normal mode.

## 5.4.5 Drawers

### Note

The energy consumption increases and the cooling performance decreases if there is insufficient ventilation.

For appliances with NoFrost:

- ▶ Leave the bottom drawer in the appliance!
- ▶ Always keep the air slits of the fan free at the rear wall!

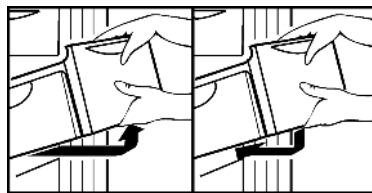

- ▶ To store frozen food directly on the shelves: pull the drawer forwards and lift it out.

## 5.4.6 Shelves

- ▶ To remove the shelf: lift up at the front and pull out.
- ▶ To put the shelf back: simply push in as far as it will go.

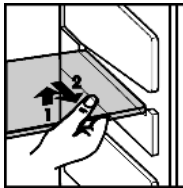

## 5.4.7 VarioSpace\*

Apart from being able to remove the drawers, you can also remove the shelves, creating space for large items of frozen food. Poultry, meat, large pieces of game and high bakery products can be frozen in one piece and prepared.

- ▶ The maximum load of frozen food for the drawers is 25 kg each and for the shelves 35 kg each.

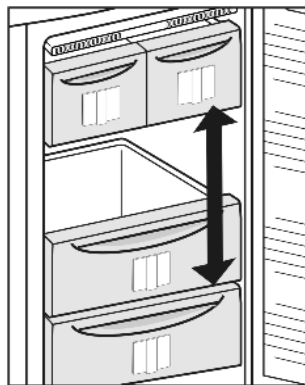

## 5.4.8 Information system\*



Fig. 11

- |                                 |                        |
|---------------------------------|------------------------|
| (1) Ready-made meals, ice cream | (4) Sausages, bread    |
| (2) Pork, fish                  | (5) Game, mushrooms    |
| (3) Fruit, vegetables           | (6) Poultry, beef/veal |

The figures indicate the storage time in months for several types of frozen food in each case. Storage times given are guide times.

## 5.4.9 Cold storage accumulators\*

The cold storage accumulators prevent the temperature from rising too fast in the event of power failure.

### Using cold storage accumulators\*

- ▶ Place the cold storage accumulators in the top freezer compartment to save space.
- ▶ Place the frozen cold storage accumulators on the frozen food in the upper front area of the freezer compartment.

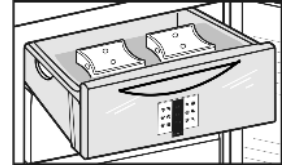

## 5.4.10 IceMaker\*

The IceMaker and the water reservoir situated in the refrigerator compartment can be used to produce ice cubes or to provide chilled drinking water.

The IceMaker is in the top drawer of the freezer compartment. The drawer is marked "IceMaker".

Make certain that the following conditions are met:

- The appliance is level.
- The appliance is connected.
- The freezer compartment is switched on.
- The water tank was cleaned with water and is filled.

### Filling the water tank\*



### WARNING

Risk of poisoning!

- ▶ The water quality has to comply with the drinking water ordinance of the respective country (e.g. 98/8
- ▶ The IceMaker serves exclusively for making ice cubes in household quantities and has to be operated with water suitable for the purpose.

### NOTICE

Risk of damage to the IceMaker!

Liquids containing sugar, such as soft drinks, fruit juices or similar, gum up the pump and therefore lead to total pump failure and, as a consequence, to damage to the IceMaker.

- ▶ Fill the water reservoir with drinking water only! Do not use any liquids containing sugar, such as soft drinks, fruit juices or similar!

The IceMaker is supplied with water from a water tank in the refrigerator compartment (see Appliance at a glance).

Before initial operation:

- ▶ clean the water tank thoroughly with water to remove any dust etc.
- ▶ Pull the water tank forwards.
- ▶ Open the front flap and fill the tank with water.

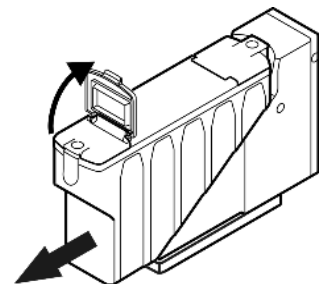

- ▶ Place the filled water tank in the holder and slide it all the way back.

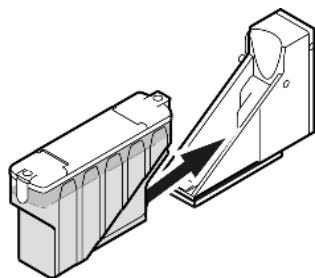

## Note

- ▶ The water reservoir has to be slid all the way into the bracket provided for the purpose in the refrigerator compartment!

## Switching on the IceMaker\*

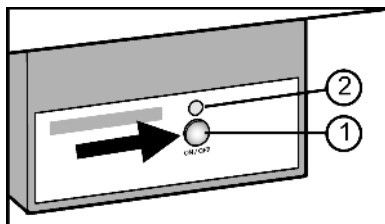

Fig. 12

- ▶ Pull out the drawer.
- ▶ Press the On/Off button Fig. 12 (1) so that the LED Fig. 12 (2) shines.
- ▶ Push in the drawer.

## Note

- ▶ The IceMaker produces ice cubes only if the drawer is fully closed.

## Producing ice cubes\*

The production capacity depends on the freezer temperature. The lower the temperature, the more ice cubes can be produced in a specific period.

The ice cubes drop from the IceMaker into the drawer. When a certain filling level has been reached, no further ice cubes are produced. The IceMaker does not fill the drawer right up to the brim.

If large quantities of ice cubes are needed, the complete IceMaker drawer can be exchanged for the adjacent drawer. When the drawer is closed, the IceMaker automatically recommences production.

Once the IceMaker has been switched on for the first time, it may take up to 24 hours until the first ice cubes are produced.

## Note

When the appliance is used for the first time and if it has been out of use for a long time, particles may collect in the IceMaker and/or water conduit.

- ▶ Therefore do not use or consume the ice cubes made in the first 24 hours.

## Switching off the IceMaker\*

If no ice cubes are needed, the IceMaker can be switched off independently of the freezer compartment.

When the IceMaker is switched off, the IceMaker drawer can also be used for freezing and storing food.

- ▶ Press the On/Off button for about 1 second until the LED goes out.
- ▶ Clean the IceMaker.
- ▷ This ensures that no water or ice remains in the IceMaker.

## 6 Maintenance

### 6.1 Defrosting with NoFrost

The NoFrost system automatically defrosts the appliance.

#### Refrigerator compartment:

The defrost water evaporates due to the compressor heat. Drops of water on the rear wall are perfectly normal.

- ▶ Regularly clean the drain opening to allow the water to flow away (see 6.2).

#### Freezer compartment:

The moisture condenses on the evaporator, is periodically defrosted and evaporates.

- ▶ The appliance does not have to be manually defrosted.

### 6.2 Cleaning the appliance



#### CAUTION

Risk of injury and damage as a result of hot steam! Hot steam may damage the surfaces and cause burns.

- ▶ Do not use any steam cleaners!

#### NOTICE

Incorrect cleaning damages the appliance!

- ▶ Do not use cleaning agents in concentrated form.
- ▶ Do not use any scouring or abrasive sponges or steel wool.
- ▶ Please do not use any aggressive, scouring, sand-, chloride-, chemical- or acid-based cleaning agents.
- ▶ Do not use chemical solvents.
- ▶ Do not damage or remove the type plate on the inside of the appliance. It is important for the customer service.
- ▶ Do not pull off, bend or damage cables or other components.
- ▶ Do not allow any cleaning water to enter the drain channel, ventilation grille or electrical parts.
- ▶ Please use soft cleaning cloths and a universal pH-neutral cleaning agent.
- ▶ Please use cleaning and care products suitable for contact with foodstuffs in the appliance interior.

- ▶ **Empty appliance.**
- ▶ **Pull out the power plug.**



- ▶ Clean **plastic outer and inner surfaces** with lukewarm water and a little washing-up liquid.

#### NOTICE

The **stainless steel doors** are finished with a high quality surface coating and must not be treated with the enclosed care product,



as otherwise the surface coating will be damaged.

- ▶ Please only use a soft clean cloth to wipe the **coated door surfaces**. In the case of heavy soiling, use a little water or neutral cleaning agent. A micro-fibre cloth can be used optionally.
- ▶ When soiled, clean **stainless steel side walls** with a commercially available stainless steel cleaning agent. Then apply the enclosed stainless steel care product evenly in the direction of polishing.
- ▶ Use only a soft clean cloth to wipe **side walls and door surfaces** with a paint finish. In the case of heavy soiling, use a little water or neutral cleaning agent. A micro-fibre cloth can be used optionally.

# Maintenance

- ▶ Clean **drain hole**: Remove deposits with a narrow instrument, e.g. a cotton bud.

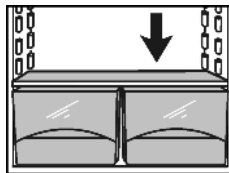

- ▶ Clean **items of equipment** by hand with lukewarm water and a little washing-up liquid.
- ▶ Remove the **support rails** for the half glass shelves for cleaning.
- ▶ To dismantle the **shelves**: remove trims and side parts.\*

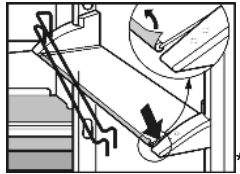

- ▶ To dismantle **door racks**: Pull off protective film from the decorative trims.\*

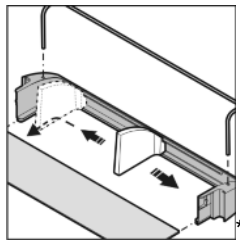

- ▶ Remove **boxes** and covers by lifting up and out.\*

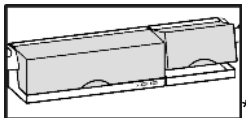

- ▶ Empty **water collect tray**: remove water tank. Carefully unlatch tray at front and then remove from below.\*

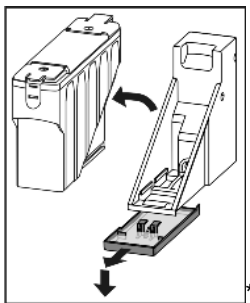

## After cleaning:

- ▶ Wipe dry the appliance and items of equipment.
- ▶ Connect the appliance and switch it on again.
- ▶ Switch on SuperFrost (see 5.4.4).
- ▶ When the temperature is sufficiently cold: Put the food back inside.

## 6.3 Cleaning the IceMaker\*

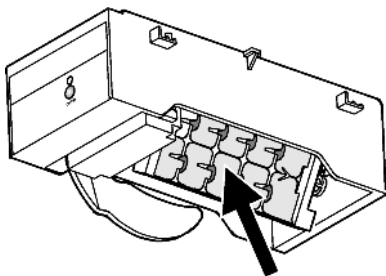

Fig. 13

- The IceMaker has to be switched on.
- ▶ Pull out the drawer and remove the ice cubes.
  - ▶ Clean the drawer with warm water and mild washing-up liquid.
  - ▶ When the drawer is pulled out, hold down the On/Off button (about 10 seconds).
  - ▶ After about 1 s the LED goes out, the IceMaker is switched off.

- ▶ After about 10 s the LED flashes for about 60 s.
- ▶ Slide in the drawer while the LED is flashing.
- ▶ The ice-cube tray of the IceMaker turns to a skew position.
- ▶ Remove the drawer.
- ▶ Clean the ice cube tray with warm water. If necessary, use mild washing-up liquid. Then rinse.
- ▶ Switch the IceMaker on again.
- ▶ Press the ON/OFF button until the LED shines, then slide in the drawer.
- ▶ The IceMaker starts producing ice cubes.
- ▶ If washing-up liquid was used: throw away the first three loads of ice cubes to get rid of any remaining washing-up liquid.

## 6.4 Changing the interior light with bulb

### Bulb data

max. 25 W  
Fitting: E14

Type of current and voltage must conform with the details on the type plate

- ▶ Switch off the appliance.
- ▶ Pull out the power plug or switch off the fuse.
- ▶ Take holder of the cover Fig. 14 (1) at the front and unhook it at the back.
- ▶ Change the bulb Fig. 14 (2).
- ▶ Put the cover Fig. 14 (1) back in place.

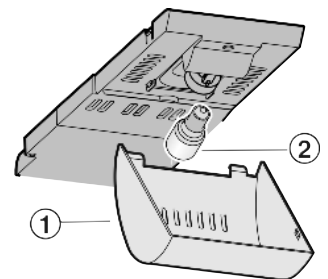

Fig. 14

## 6.5 Customer service

First check whether you can correct the fault yourself by reference to the list (see Malfunction). If this is not the case, please contact the customer service whose address is given in the enclosed customer service list.



### WARNING

Risk of injury if repair work is not carried out professionally!

- ▶ Have any repairs and action - not expressly specified - on the appliance and mains cable carried out by service personnel only. (see Maintenance)

- ▶ Read the appliance designation Fig. 15 (1), service No. Fig. 15 (2) and serial No. Fig. 15 (3) off the type plate located inside the appliance on the left-hand side.

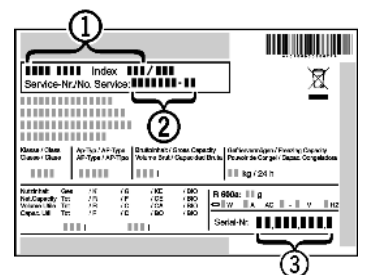

Fig. 15

- ▶ Notify the customer service, specifying the fault, appliance designation Fig. 15 (1), service No. Fig. 15 (2) and serial No. Fig. 15 (3).
- ▶ This will help us to provide you with a faster and more accurate service.
- ▶ Keep the appliance closed until the customer service arrives.
- ▶ The food will stay cool longer.
- ▶ Pull out the mains plug (not by pulling the connecting cable) or switch off the fuse.

## 7 Malfunction

Your appliance is designed and manufactured for a long life span and reliable operation. If a malfunction nonetheless occurs during operation, check whether it is due to a handling error. In this case you will have to be charged for the costs incurred, even during the warranty period. You may be able to rectify the following faults yourself:

### Appliance does not work.

- The appliance is not switched on.
- ▶ Switch on the appliance.
- The power plug is not properly inserted in the wall socket.
- ▶ Check power plug.
- The fuse of the wall socket is not in order.
- ▶ Check fuse.

### The compressor runs for a long time.

- The compressor switches to a low speed when little cold is needed. Although the running time is increased as a result, energy is saved.
- ▶ This is normal in energy-saving models.
- SuperFrost is activated.
- ▶ The compressor runs for longer in order to rapidly cool the food. This is normal.

### A LED on the bottom rear of the appliance (at the compressor) flashes regularly every 15 seconds\*.

- The inverter is equipped with a diagnostic LED.
- ▶ The flashing is normal.

### Excessive noise.

- Speed-controlled\* compressors may produce varying running noise due to different speed steps.
- ▶ The sound is normal.

### A bubbling and gurgling noise.

- This noise comes from the refrigerant flowing in the refrigeration circuit.
- ▶ The sound is normal.

### A quiet clicking noise.

- The noise is produced whenever the refrigeration unit (motor) automatically switches on or off.
- ▶ The sound is normal.

### A hum. It is briefly a little louder when the refrigeration unit (the motor) switches on.

- The refrigeration increases automatically when the SuperFrost, function is activated, fresh food has just been placed in the appliance or the door has been left open for a while.
- ▶ The sound is normal.
- The ambient temperature is too high.
- ▶ Solution: (see 1.2)

### A low hum.

- The sound is produced by air flow noise of the fan.
- ▶ The sound is normal.

### Vibratory noise.

- The appliance is not standing firmly on the floor. As a result, adjoining units or objects are set into vibration by the running refrigeration unit.
- ▶ Move the appliance away a little and align it using the adjustable feet.
- ▶ Move bottles and containers apart.

### Hum of the water tank pump.\*

- When water is pumped out of the water reservoir, a brief hum of the pump can be heard.
- ▶ The sound is normal.

### The SuperFrost button flashes together with the temperature display.

- There is a fault.
- ▶ Contact the customer service. (see Maintenance).

### The outside surfaces of the appliance are warm.

- The heat of the refrigeration circuit is used to prevent condensate from forming.
- ▶ This is normal.

### The IceMaker cannot be switched on.\*

- The appliance and therefore the IceMaker are not connected.
- ▶ Connect the appliance. (see Putting into operation).

### The IceMaker does not make any ice cubes.\*

- The IceMaker is not switched on.
- ▶ Switch on the IceMaker.
- The drawer of the IceMaker is not properly closed.
- ▶ Close the drawer properly.
- The water tank is not correctly inserted.
- ▶ Insert the water tank.
- There is not enough water in the water tank.
- ▶ Fill the water tank.

### The LED of the IceMaker flashes.\*

- There is not enough water in the water tank.
- ▶ Fill the water tank.
- If the LED flashes and the water tank is full, the IceMaker is defective.
- ▶ Contact the customer service. (see Maintenance).

### The temperature is not cold enough.

- The door of the appliance is not properly closed.
- ▶ Close the door of the appliance.
- Insufficient ventilation.
- ▶ Clear ventilation grilles.
- The ambient temperature is too high.
- ▶ Solution: (see 1.2) .
- The appliance was opened too frequently or for too long.
- ▶ Wait until the appliance reaches the required temperature itself. If not, contact the customer service. (see Maintenance).
- Too much fresh food was placed inside without SuperFrost.
- ▶ Solution: (see 5.4.4)
- The appliance is too close to a heat source.
- ▶ Solution: (see Putting into operation).

### The interior light is not on.

- The appliance is not switched on.
- ▶ Switch on the appliance.
- The door was open longer than 15 min.
- ▶ The interior light automatically switches off if the door has been open for about 15 min.
- If the interior light is not on but the temperature display is lit, the bulb is faulty.
- ▶ Change the bulb. (see Maintenance).

## 8 Decommissioning

### 8.1 Switching off the appliance

#### Note

- ▶ To switch on the entire appliance it is necessary only to switch off the freezer compartment. In so doing, the refrigerator compartment is automatically switched off as well.

#### 8.1.1 Switching off the freezer compartment

- ▶ Press ON/OFF button, freezer compartment *Fig. 3 (9)* for at least 3 seconds.
- ▷ The temperature displays are dark. The entire appliance is switched off.

# Disposing of the appliance

---

## 8.1.2 Switching off the refrigerator compartment

- ▶ Press ON/OFF button, refrigerator compartment *Fig. 3 (1)* for at least 3 seconds.
- ▷ The interior light is off.
- ▷ The temperature display of the refrigerator compartment is dark.

---

### Note

- ▶ If only the refrigerator compartment is to be switched off, e.g during holidays, then always pay attention: the freezer compartment temperature display has to shine.
- 

## 8.2 Taking the appliance out of service

- ▶ Empty the appliance.
- ▶ Put the IceMaker in the cleaning position (see Maintenance).
- ▶ Pull out the power plug.
- ▶ Clean the appliance (see 6.2) .



- ▶ Leave the door open to prevent odour.

## 9 Disposing of the appliance

The appliance contains some reusable materials and should be disposed of properly - not simply with unsorted household refuse. Appliances which are no longer needed must be disposed of in a professional and appropriate way, in accordance with the current local regulations and laws.



When disposing of the appliance, ensure that the refrigeration circuit is not damaged to prevent uncontrolled escape of the refrigerant it contains (data on type plate) and oil.

- ▶ Disable the appliance.
- ▶ Pull out the plug.
- ▶ Cut through the connecting cable.