

1996 CONTINENTAL

Your satisfaction is our #1 goal. If you have questions or concerns with your vehicle, we suggest you follow these steps:

1. Contact your Sales Representative or Service Advisor at your selling/servicing dealership.
2. If the inquiry or concern remains unresolved, contact the Sales Manager or Service Manager at the dealership.
3. If the inquiry or concern cannot be resolved at the dealership level, please contact the Ford Customer Assistance Center.

In the United States:

**Ford Motor Company
Lincoln Customer Assistance Center
300 Renaissance Center
P.O. Box 43360
Detroit, MI 48243
1-800-521-4140
TDD for the hearing impaired: 1-800-232-5952**

In Canada:

**The Lincoln Centre
Ford Motor Company of Canada, Limited
P.O. Box 1580, Station B
Mississauga, Ontario L4Y 4G3
1-800-387-9333**

Outside the U.S. or Canada:

**FORD MOTOR COMPANY EXPORT OPERATIONS
1555 Fairlane Drive
Fairlane Business Park #3
Allen Park, Michigan 481 01
Telephone (313) 594-4857
Fax (313) 390-0804**

All rights reserved. Reproduction by any means, electronic or mechanical, including photocopying, recording, or by any information storage and retrieval system or translation in whole or part is not permitted without written authorization from Ford Motor Company.

Copyright @ 1995, Ford Motor Company

Table of Contents

INTRODUCTORY INFORMATION	1
SAFETY RESTRAINTS	9
STARTING YOUR CONTINENTAL	41
WARNING LIGHTS AND GAUGES	51
INSTRUMENT PANEL CONTROLS	69
STEERING COLUMN CONTROLS	89
FEATURES	99
ELECTRONIC SOUND SYSTEMS	159

<u>DRIVING YOUR CONTINENTAL</u>	179
<u>ROADSIDE EMERGENCIES</u>	199
<u>CUSTOMER ASSISTANCE</u>	213
<u>ACCESSORIES</u>	223
<u>SERVICING YOUR CONTINENTAL</u>	231
<u>QUICK INDEX</u>	299
<u>INDEX</u>	307
<u>GAS STATION INFORMATION</u>	322

Introductory Information

Ford's Commitment to You

At Ford Motor Company, excellence is the continuous commitment to achieve the best result possible. It is dedication to learning what you want, determination to develop the right concept, and execution of that concept with care, precision, and attention to detail. In short, excellence means being the standard by which others are judged.

Our Guiding Principles

- ❑ **Quality comes first.** For your satisfaction, the quality of our products and services must be our number one priority.
- ❑ **You are the focus of everything we do.** Our work must be done with you in mind, providing better products and services than our competition.

- ❑ **Continuous improvement is essential to our success.** We must strive for excellence in everything we do: in our products - in their safety and value - and in our services, our human relations, our competitiveness, and our profitability.
- ❑ **Employee involvement is our way of life.** We are a team. We must treat one another with trust and respect.
- ❑ **Dealers and suppliers are our partners.** We must maintain mutually beneficial relationships with dealers, suppliers, and our other business associates.
- ❑ **Integrity is never compromised.** Our conduct worldwide must be pursued in a manner that is socially responsible and commands respect for its integrity and for its positive contributions to society

Things to Know About Using This Guide

Congratulations on the purchase of your new vehicle. This guide has information about the equipment and the options for your new vehicle. You may not have bought all of the options available to you. If you do not know which information applies to your vehicle, talk to your dealer.

This guide describes equipment and gives specifications for equipment that was in effect when this guide was approved for printing. Ford may discontinue models or change specifications or design without any notice and without incurring obligation.

NOTES and WARNINGS

NOTES give you additional information about the subject matter you are referencing.

WARNINGS remind you to be especially careful in those areas where carelessness can cause damage to your vehicle or personal injury to yourself, your passengers or other people. Please read all **WARNINGS** carefully.

! WARNING

Finding Information in This Guide

After you have read this guide once, you will probably return to it when you have a specific question or need additional information. To help you find specific information quickly, you can use the Quick Index or the Index.

The **Quick Index** at the end of the book provides a page number following each item which indicates where detailed information can be found.

To use the **Index**, turn to the back of the book and search in the alphabetical listing for the word that best describes the information you need. If the word you chose is not listed, think of other related words and look them up. We have designed the Index so that you can find information under a technical term.

Canadian Owners - French Version

French Owner Guides can be obtained from your dealer or by writing to Ford Motor Company of Canada, Limited, Service Publications, P.O. Box 1580, Station B, Mississauga, Ontario L4Y 4G3.

The Lincoln Commitment

The Lincoln Commitment is more than the prestige of owning a superior luxury automobile, it is a comprehensive owner benefits package that is designed to provide you with services to support your every driving need.

The following is a brief explanation of the Lincoln Commitment benefits. We encourage you to learn about these benefits and take full advantage of them. Detailed information on all of these benefits will be sent to you approximately 25 days after you have taken delivery of your vehicle.

Service Loaner

Should your Lincoln require overnight warranty service, your dealership will provide you with a service loaner car, when available, or a rental allowance of up to \$30 a day for up to five days.

Roadside Service Assistance

Lincoln owners receive complimentary 24-hour emergency roadside service assistance for a period of four years for towing, jump-starting, lock-out service, gas delivery, a tire change or other roadside services. Call the hotline at **1-800-521-4140** any time of day or night for emergency roadside assistance.

Emergency Travel Expense Reimbursement

Covers expenses such as meals, lodging and car rental if your automobile is disabled more than 100 miles (160 km) from home.

Destination Assistance (U.S. only)

In the event of a collision or mechanical breakdown, Lincoln helps get you to your immediate destination with a reimbursement allowance for emergency transportation service such as taxicabs, rental cars, shuttles, etc.

Trip Planning Service

Plan your journeys with custom-computerized, travel-related information including maps and trip routings. To order customer-designed travel packets, call 1-800-521-4140.

Membership in Quest® International (U.S. only)

You will automatically receive a complimentary membership in Quest International which entitles you to travel-related discounts on meals and rooms at more than 2,100 hotels in the United States, Canada, Mexico and the Caribbean.

The Lincoln Warranty

For specifics on what is covered, see your *Warranty Information Booklet*.

Lincoln Customer Assistance Center

If you have questions regarding your Lincoln or the Lincoln Commitment, call our Customer Assistance Center:

United States 1-800-521-4140

Canada 1-800-387-9333

You may call the Customer Assistance Center, Monday through Friday, 8 a.m. to 5 p.m. in all time zones.

Owner Identification Card

Personalized with your name and vehicle identification number as well as the hotline number to call for customer service or roadside assistance service.

Your Maintenance Schedule and Record Booklet

The Maintenance Schedule and Record booklet lists the services that are most important for keeping your vehicle in good condition. A record log is also provided to help you keep track of all services performed.

About the Warranties

Your vehicle is covered by three types of warranties: **Basic Vehicle Warranty**, **Extended Warranties** on certain parts, and **Emissions Warranties**.

Read your *Warranty Information Booklet* carefully to find out about your vehicle's warranties and your basic rights and responsibilities.

If you lose your *Warranty Information Booklet*, you can get a new one free of charge. Contact any Ford or Lincoln-Mercury dealer, or refer to the addresses and phone numbers on the first page of this owner guide.

Buying a Ford Extended Service Plan

If you bought your vehicle in the U.S., you can buy a Ford Extended Service Plan for your vehicle. This optional contract provides service protection for a longer period of time than the basic warranty that comes with your vehicle.

You do not have to buy this option when you buy your vehicle. However, your option to purchase the Ford Extended Service Plan runs out after **18** months or 18,000 miles. See your dealer for more details about the Ford Extended Service Plan.

If you purchased a Canadian vehicle and did not take advantage of the Ford Extended Service Plan at the time of purchase, you may still be eligible. See your dealer for the details.

Breaking Your Vehicle In

Your new vehicle goes through an adjustment or break-in period during the first 1,000 miles (1,600 km) that you drive it. During the break-in period, you need to pay careful attention to how you drive your vehicle.

□ Avoid sudden stops. Because your vehicle has new brake linings, you should take these steps:

- Watch traffic carefully so that you can anticipate when to stop.
- Begin braking well in advance.
- Apply the brakes gradually.

The break-in period for new brake linings lasts for 100 miles (160 km) of city driving or 1,000 miles (1,600 km) of highway driving.

- Use only the type of engine oil that Ford recommends. See *Engine oil recommendations* in the Index. Do not use special "break-in" oils.

Cleaning the Outside of Your Vehicle

Washing and Polishing Your Vehicle

Wash the outside of your vehicle, including the underside, with a mild detergent.

DO NOT:

- Wash your vehicle with hot water
- Wash your vehicle while it sits in direct sunlight
- Wash your vehicle while the body is hot

Pollen, bird droppings and tree sap can damage the paint, especially in hot weather. Wash your vehicle as often as necessary to keep it clean.

Take similar precautions if your vehicle is exposed to chemical industrial fallout.

Paint damage resulting from fallout is not related to a defect in paint materials or workmanship and therefore is not covered by warranty. Ford, however, believes that continual improvement in customer satisfaction is a high priority. For this reason, Ford has authorized its dealers to repair, at no charge to the owner, the surfaces of new vehicles damaged by environmental fallout within 12 months or 12,000 miles (20,000 km) of purchase, whichever comes first. Customers may be required to bring their vehicle in for inspection by a Ford representative.

Polish your vehicle to remove harmful deposits and protect the finish.

Cleaning Chrome and Aluminum Parts

Wash chrome and aluminum parts with a mild detergent. Do not use steel wool, abrasive cleaners, fuel, or strong detergents.

Cleaning Plastic Parts

Some of your vehicle's exterior trim parts are plastic. Clean with a tar and road oil remover if necessary. Use a vinyl cleaner for routine cleaning.

Do not clean plastic parts with thinners, solvents or petroleum-based cleaners.

If you have your vehicle rustproofed, remove oversprayed rustproofing with a tar and road oil remover. If rustproofing is not removed from plastic and rubber parts, it can cause deterioration.

Safety Restraints

Important Safety Belt Information

The use of safety belts helps to restrain you and your passengers in case of a collision. In most states and in Canada the law requires their use.

Safety belts provide best restraint when:

- the seatback is upright
- the occupant is sitting upright (not slouched)
- the lap belt is snug and low on the hips
- the shoulder belt is snug against the chest
- the knees are straight forward

To help you remember to fasten your safety belt, a warning light may come on and a chime may sound. See *Safety Belt Warning Light and Chime in the Warning Lights and Gauges chapter*.

See the following sections in this chapter for directions on how to properly use these safety belts. Also see *Safety Restraints for Children* in this chapter for special instructions about using safety belts for children.

/!\ WARNING

Make sure that you and your passengers wear safety belts. Always drive and ride with your seatback upright and the lap belt snug and low across the hips.

!\\ WARNING

Never wear the shoulder belt under the arm. Never swing it around the neck over the inside shoulder. Never use a single belt for more than one person or across more than one seating position. Each seating position in your vehicle has a specific safety belt assembly which is made up of one buckle and one tongue that are designed to be used as a pair. Failure to follow these precautions could increase the risk and/or severity of injury in a collision.

!\\ WARNING

Never drive or ride with a twisted or jammed safety belt. If you cannot untwist or unjam the safety belt, see the nearest qualified technician immediately.

!\\ WARNING

To reduce the risk of serious injury in a collision, children should always ride with the seatback upright.

!\\ WARNING

Never let a passenger hold a child on his or her lap while the vehicle is moving. The passenger cannot protect the child from injury in a collision.

Lock the doors of your vehicle before driving to lessen the risk of the door coming open in a collision.

Combination Lap and Shoulder Belts

While your vehicle is in motion, the combination lap and shoulder belt adjusts to your movement.

However, if you brake hard, corner hard or if your vehicle receives an impact of 5 mph (8 km/h) or more, the lap and shoulder belt locks and helps reduce your forward movement.

After you get into your vehicle, close the door and lock it. Then adjust the seat to the position that suits you best.

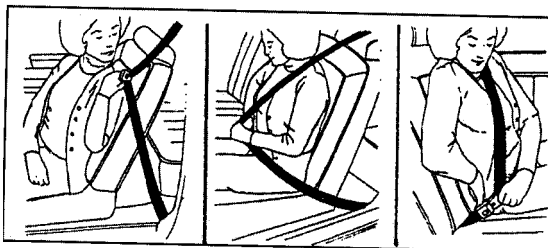

Fastening the combination lap and shoulder belt

NOTE: Be sure to read and understand *Important Safety Belt Information* at the beginning of this chapter.

To adjust the lap part of the belt, pull up on the shoulder belt until the lap belt fits snugly and as low as possible around your hips.

While the belt retracts, guide the tongue to its original position to prevent it from striking you or the vehicle.

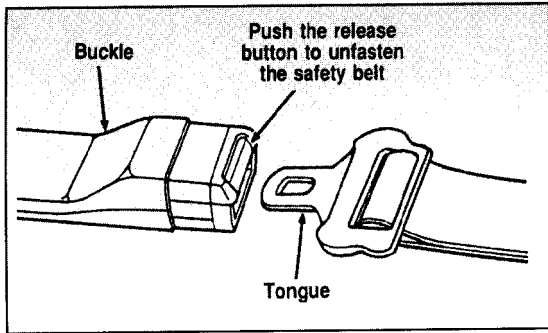

Unfastening the lap/shoulder belts

Shoulder Belt Height Adjustment

Driver and right front passenger

You can adjust the shoulder belt height to one of five (5) positions.

To adjust the belt down, push the release button (see figures I and 2). To adjust the belt up, slide the adjuster up. (You do not have to push the release button.)

Make sure the adjuster is firmly in one of the five positions. The belt should be adjusted up or down until the belt rests on your shoulder near your neck.

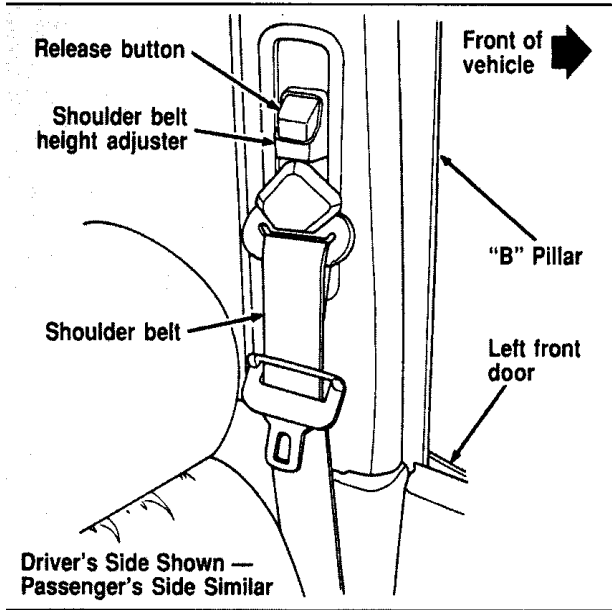

Figure 1 - The shoulder belt height adjuster

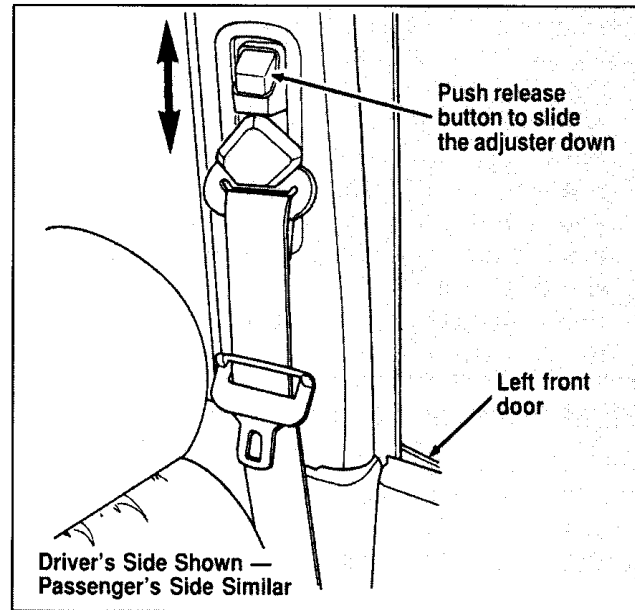

Figure 2 - The shoulder belt height adjuster

! WARNING

Position the shoulder belt height adjuster so that the belt rests across the middle of your shoulder. Be sure the shoulder belt is properly positioned on your shoulder each time you use the belt. If the shoulder belt is off your shoulder, on your upper arm or neck, there is a greater risk of severe injury in a collision.

Right Front or Rear Seating Positions

Your vehicle is equipped with a dual locking mode retractor on the shoulder belt portion of the combination lap/shoulder safety belt for the front seat passenger and rear seat passengers.

Dual locking mode retractors operate in two ways:

Vehicle sensitive (emergency) locking mode

In this operating mode, the shoulder belt retractor will allow the occupant freedom of movement, locking tight only on hard braking, hard cornering or impacts of approximately 5 mph (8 km/h) or more. The retractor can also be made to lock by pulling on the belt.

Automatic locking mode

In this operating mode, the shoulder belt retractor will be automatically locked and will remain locked when the combination lap/shoulder safety belt is buckled, and does not allow the occupant freedom of movement. This mode provides the following:

- A tight lap/shoulder belt on the occupant.
- Child seat installation restraint.

⚠ WARNING

Rear facing infant seats should never be placed in the front seat.

This mode must be used when installing a child seat on the front passenger seat and rear seats where dual locking retractors are provided. To switch the retractor from the emergency locking mode to the automatic locking mode, perform the following steps:

1. Buckle the lap/shoulder combination belt.
2. Grasp the shoulder portion of the belt and pull downward until all of the belt is extracted and a click is heard. At this time, the retractor is in the automatic locking mode (child restraint mode).

3. A clicking sound will continue to be heard as the belt is allowed to retract.

NOTE: When the combination lap/shoulder belt is unbuckled and allowed to retract completely, the retractor will switch to the vehicle sensitive (emergency) locking mode. See the detailed instructions under *Safety Seats for Children* in this chapter.

Lap Belts

The lap belt in the center of the front seat does not adjust automatically. You must adjust it to fit snugly and as low as possible around your hips. Do not wear it around your waist.

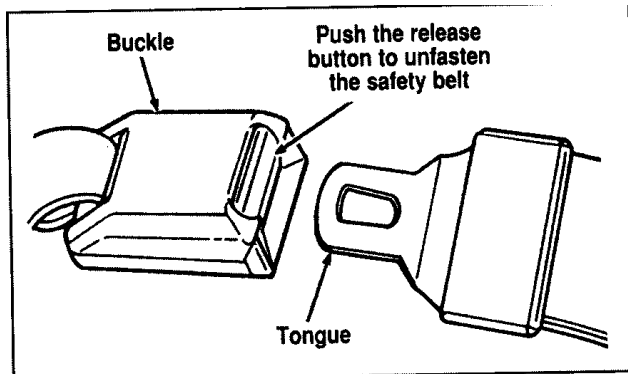

Unfastening the lap belts in the center front seating position

NOTE: Be sure to read and understand *Important Safety Belt Information* at the beginning of this chapter.

Pull the belt across your hips and **insert the tongue into the correct buckle** on your seat until you hear a snap and feel it lock. Make sure the buckle is securely fastened.

If you need to lengthen the belt, unfasten it and tip the belt tongue at a right angle to the belt. Pull the belt tongue over your lap until it reaches the buckle.

If you need to shorten the belt, pull on the loose end of the webbing until the belt fits snugly.

To unfasten the belt, push the release button on the buckle. This allows the tongue to unlatch from the buckle.

Safety Belt Extension Assembly

For some people, the safety belt may be too short even when it is extended. You can add about eight inches (20 cm) to the belt length with a safety belt extension assembly (part number 611 C22). Safety belt extensions are available at no cost from your dealer.

on the label. Also, use the safety belt extension only if the safety belt is too short for you when fully extended. Do not use extension to change the fit of the shoulder belt across the torso.

⚠ WARNING

Failure to follow these instructions will affect the performance of the safety belts and increase the risk of personal injury.

Safety Belt Maintenance

Check the safety belt systems periodically to make sure that they work properly and are not damaged.

All safety belt assemblies, including refractors, buckles, front seat belt buckle support assemblies (slide bar) (if equipped), child safety seat tether bracket assemblies (if equipped), and attaching hardware, should be inspected after any collision. Ford recommends that all safety belt assemblies used in vehicles involved in a collision be replaced.

However, if the collision was minor and a qualified technician finds that the belts do not show damage and continue to operate properly, they do not need to be replaced. Safety belt assemblies not in use during a collision should also be inspected and replaced if either damage or improper operation is noted.

Cleaning the Safety Belts

Clean the safety belts with any mild soap solution that is recommended for cleaning upholstery or carpets. Do not bleach or dye the belt webbing because this may weaken it.

Air Bag Supplemental Restraint System (SRS)

The driver and right front passenger air bags are Supplemental Restraint Systems (SRS), provided at these seating positions in addition to the lap/shoulder belt, and are designed to supplement the protection provided to properly belted occupants

in moderate to severe frontal collisions. The supplemental air bag system does not provide restraint to the lower body.

!WARNING

The supplemental air bags are not designed to protect occupants in the front center seating position.

The Importance of Wearing Safety Belts

!WARNING

Safety belts must be worn by all vehicle occupants to be properly restrained and help reduce the risk of injury in a collision.

!WARNING

All occupants of the vehicle, including the driver, should always wear their safety belts, even when an air bag Supplemental Restraint System is provided.

There are four very important reasons to use safety belts even with an air bag system. Use your safety belts to:

- help keep you in the proper position (away from the air bag) when it inflates
- reduce the risk of harm in rollover, side or rear impact collisions, because an air bag is not designed to inflate in such situations
- reduce the risk of harm in frontal collisions that are not severe enough to activate the supplemental air bag
- reduce the risk of being thrown from your vehicle

The Importance of Being Properly Seated

In a collision, the air bag must inflate extremely fast to help provide additional protection for you. In order to do this, the air bag must inflate with considerable force. If you are not seated in a normal riding position with your back against the seatback, the air bag may not protect you properly and could possibly hurt you as it inflates.

! WARNING

If a passenger is not properly seated and restrained, an inflating air bag could cause serious injury.

In rear-facing infant seats, the infant's head is closer to the air bag. The force of the rapidly inflating air bag could push the top of the rear-facing seat against the vehicle seatback or center armrests (if so equipped), or center console (if so equipped).

Children weighing less than 40 lbs. (18 kg.) should use child or infant seats. Forward facing child seats must have the passenger seat moved as far back from the instrument panel as possible.

Your vehicle is equipped with a right front passenger air bag. Front passengers, especially children and small adults, should never sit on the edge of the seat, stand near the glove compartment of the instrument panel, or lean over with their faces near the glove compartment when the vehicle is moving. All occupants should sit with their backs against the seatback and use the safety belts.

/! WARNING

REAR-FACING INFANT SEATS SHOULD NEVER BE USED IN THE FRONT SEAT. REAR-FACING INFANT SEATS MUST ALWAYS BE PLACED IN THE REAR SEAT. Failure to follow these instructions could result in serious injury.

/! WARNING

Do not place objects or mount equipment on or near the air bag cover on the steering wheel or in front seat areas that may come in contact with a deploying air bag. Failure to follow this instruction may increase the risk of personal injury in the event of a collision.

For further information about the proper mounting of equipment in the front seat of this vehicle, please refer to Ford's brochure entitled *Some Important Information About Air Bag Supplemental Restraint System* which can be obtained by calling Helm Inc. at 1-800-782-4356. Ask for brochure FPS-8602.

For additional important safety information on the proper use of seat belts, child seats, and infant seats, please read the other sections of this part of the Owner Guide, especially sections entitled *Safety Belts for Children and Safety Seats for Children*.

How the Air Bag Supplemental Restraint System Operates

The Air Bag Supplemental Restraint System consists of the Driver and Passenger air bags, impact sensors, a system diagnostic module, a readiness light and tone, and the electrical wiring which connects the components.

The driver air bag is in the center of the steering wheel and is indicated by the letters SRS. The right front passenger seat air bag is in the upper right-hand section of the instrument panel ledge above the glove compartment. The letters SRS appear there. Both air bags are designed to stay out of sight until they are activated.

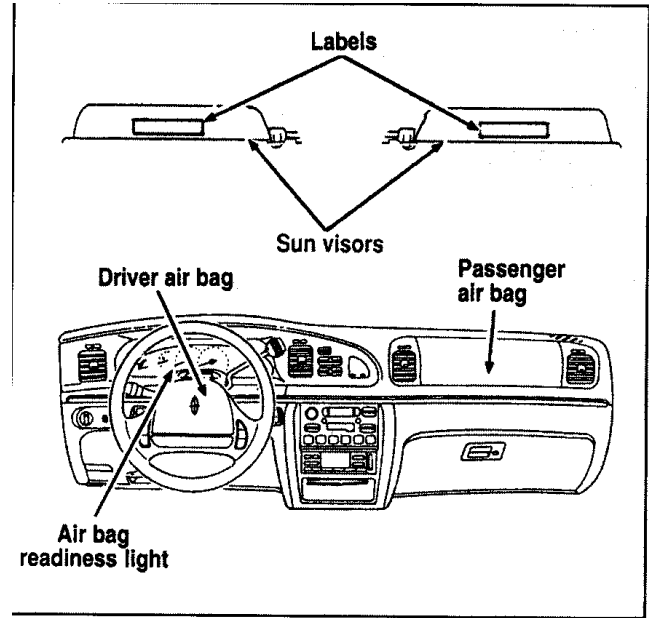

The location of air bags and warning labels

If a collision occurs, the sensors sense the severity of the impact and activates the air bags if necessary. The air bag system is designed to deploy in frontal and front-angled collisions more severe than hitting a parked vehicle (of similar size and weight) head-on at about 28 mph (45 km/h). Because the system senses the crash severity rather than vehicle speed, some frontal collisions at speeds above 28 mph (45 km/h) will not inflate the air bag.

When the sensors activate the system, the air bags inflate rapidly, filling with non-toxic nitrogen gas in a fraction of a second. Immediately after inflation, the air bags deflate by releasing the nitrogen gas through vent holes. The whole process takes place in a matter of seconds.

! WARNING

Air bag system components get hot after inflation. Do not touch them after inflation.



Inflated driver side air bag

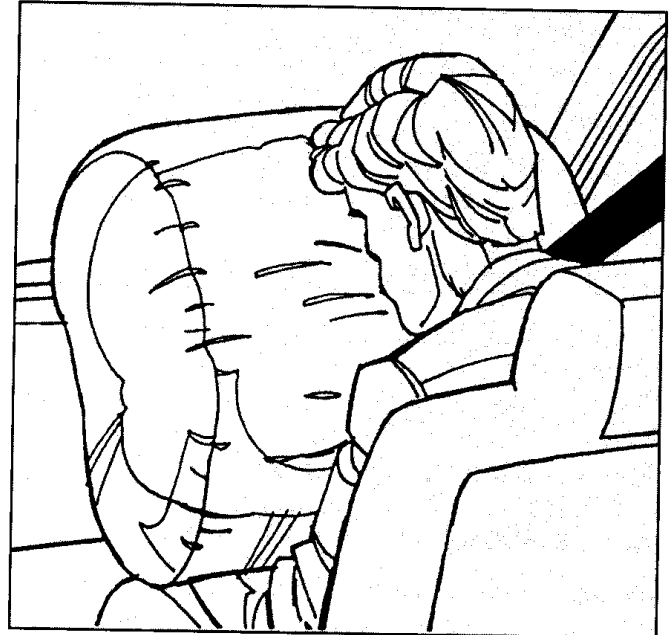

Inflated Passenger side air bag

!/\ WARNING

If the air bag is inflated, THE AIR BAG WILL NOT FUNCTION AGAIN AND MUST BE REPLACED IMMEDIATELY. If the air bag is not replaced, the unrepaired area will increase the risk of injury in a collision.

To ensure that the air bag system will operate as intended in a crash, the system is equipped with a diagnostic module, which controls a readiness lamp and a warning tone. The diagnostic module monitors its own circuits, the air bag electrical system, the air bag readiness light, the air bag power, and the air bag inflators.

The air bag system uses a readiness light on the instrument cluster and a tone to indicate the condition of the system. When you turn the ignition key to the ON position, this light will illuminate for approximately six (6) seconds and then turn off.

This indicates that the system is operating normally. NOTE: Maintenance of the air bag system is not required.

**AIR
BAG**

- A problem with the system is indicated by one or more of the following:
- the readiness light will either flash or stay lit,
- or it will not light immediately after ignition is turned on,
- or a group of five beeps will be heard. The tone pattern will repeat periodically until the problem and light are repaired.

If any of these things happen, have the air bag system serviced at your Ford or Lincoln-Mercury dealer immediately. Unless serviced, the air bag supplemental restraint system may not function properly in the event of a collision.

/! WARNING

Do not attempt to service, repair, or modify the Air Bag Supplemental Restraint System or its fuses. See your Ford or Lincoln-Mercury dealer.

Disposal of air bags or air bag equipped vehicles

For disposal of air bags or air bag equipped vehicles, see your local Ford or Lincoln-Mercury dealer. Air bags **MUST** be disposed of by qualified personnel.

Safety Restraints for Children

In the U.S. and Canada, you are required by law to use safety restraints for children. If small children ride in your vehicle - this generally includes children who are four years old or younger and who weigh 40 pounds (18 kg) or less - you must put them in safety seats that are made specially for children. Safety belts alone do not provide maximum protection for these children. Check your local and state laws for specific requirements.

/! WARNING

Never let a passenger hold a child on his or her lap while the vehicle is moving. The passenger cannot protect the child from injury in a collision.

/! WARNING

Passengers should not be allowed to ride in the cargo area. Persons not riding in a seat with a fastened seat belt are much more likely to suffer serious injury in a collision. Cargo should always be secured to prevent it from shifting and causing damage to the vehicle or harm to passengers.

When possible, put children in the rear seat, of your vehicle. Accident statistics suggest that children are safer when properly restrained in the rear seating positions than in the front seating positions.

/! WARNING

Carefully follow all of the manufacturer's instructions included with the safety seat you put in your vehicle. If you do not install and use the safety seat properly, the child may be injured in a sudden stop or collision.

/! WARNING

Safety belts and seats can become hot in a vehicle that has been closed up in sunny weather; they could burn a small child. Check seat covers and buckles before you place a child anywhere near them.

/! WARNING

Never leave a child unattended in your vehicle.

Safety Seats for Children

Use a safety seat that is recommended for the size and weight of the child. Always follow the safety seat manufacturer's instructions when installing and using the safety seat.

Ford recommends the use of a child safety seat having a top tether strap. Install the child safety seat in a seating position which is capable of providing a tether anchorage. For more information on top tether straps see *Attaching Safety Seats With Tether Straps* in this chapter.

When installing a child safety seat, be sure to use the correct safety belt buckle for that seating position, and make sure the tongue is securely fastened in the buckle.

⚠️WARNING

REAR-FACING INFANT SEATS SHOULD NEVER BE USED IN THE FRONT SEAT. REAR-FACING INFANT SEATS MUST ALWAYS BE PLACED IN THE REAR SEAT. Failure to follow these instructions could result in serious injury.

When using forward-facing child seats in the front seat, always move the passenger seat as far back from the instrument panel as possible. Failure to follow these warnings could result in injury to the child.

All child restraint systems are designed to be secured in vehicle seats by lap belts or by the lap portion of a lap-shoulder belt.

/!\WARNING

If you do not properly secure the safety seat, the child occupying the seat may be injured during a collision or sudden stop. An unsecured safety seat could also injure other passengers.

/!\WARNING

Always keep the buckle release button pointing upward and away from the child seat, with the tongue between the child seat and the release button as shown in the following illustration.

/!\WARNING

Carefully follow all of the manufacturer's instructions included with the safety seat you put in your vehicle. If you do not install and use the safety seat properly, the child may be injured in a sudden stop or collision.

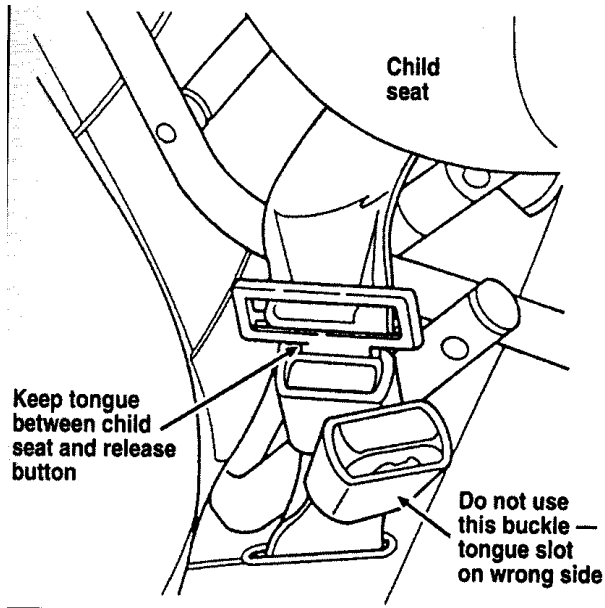

Safety belt buckle placement for child seats

Installing Safety Seats in the Front and Rear Seating Positions

Your vehicle is equipped with a dual locking mode retractor on the shoulder belt portion of the combination lap/shoulder safety belt for the front seat passenger and rear passengers.

If you choose to install a child safety seat in the front seating position, move vehicle seat as far back as possible.

For seating positions equipped with a dual-locking mode retractor, use the following procedure:

1. Position the child seat in center of passenger seat.
2. Pull down on shoulder belt, then grasp shoulder belt and lap belt together. Figure 1.

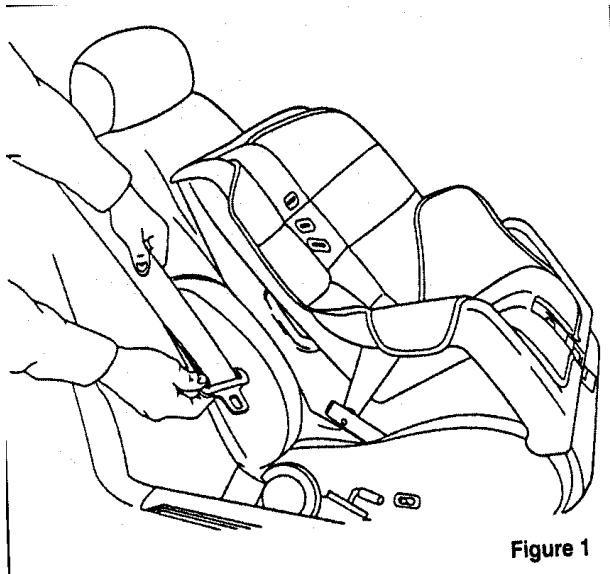

Figure 1

3. While holding the shoulder and lap belt portions together, route the tongue through the child seat according to the child seat manufacturer's instructions. See Figure 2. Be sure that the belt webbing is not twisted.

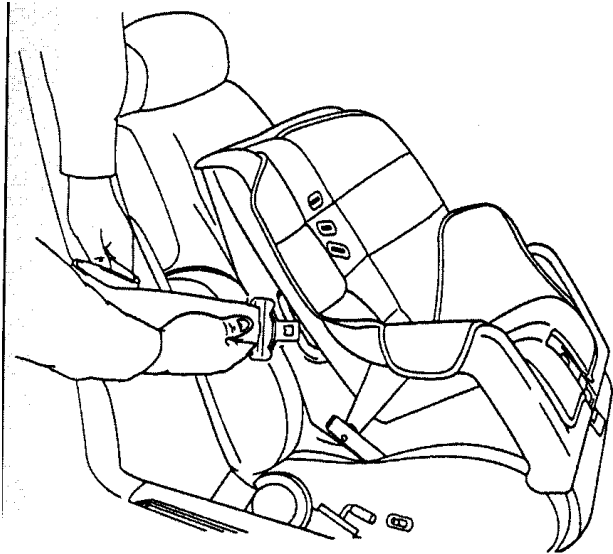

Figure 2

Routing the lap/shoulder belt

4. Insert the belt tongue into the proper buckle for that seating position until you hear and feel the latch engage. See Figure 3. Make sure tongue is latched securely to buckle by pulling on tongue.

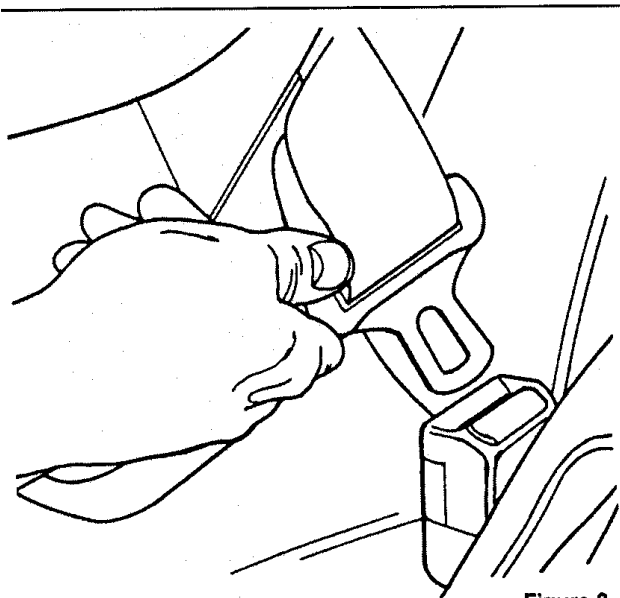

Figure 3

Buckling the belt

5. Grasp the shoulder portion of the belt and pull downward until all of the belt is extracted and a click is heard. At this time, the retractor is in the automatic locking mode (child restraint mode). See Figure 4.

NOTE: The dual locking mode retractor must be in the automatic locking mode to properly restrain a child seat.

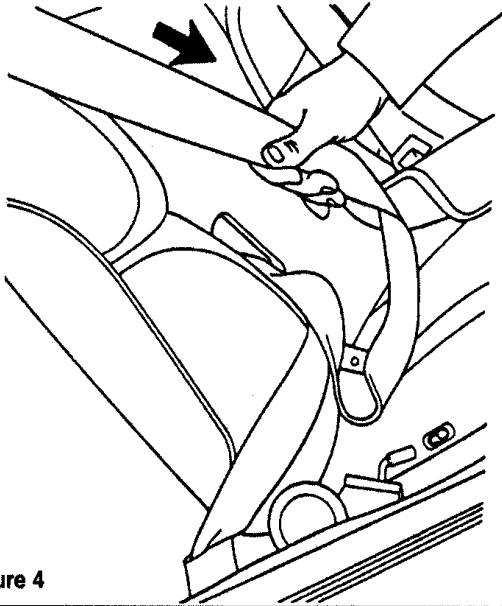
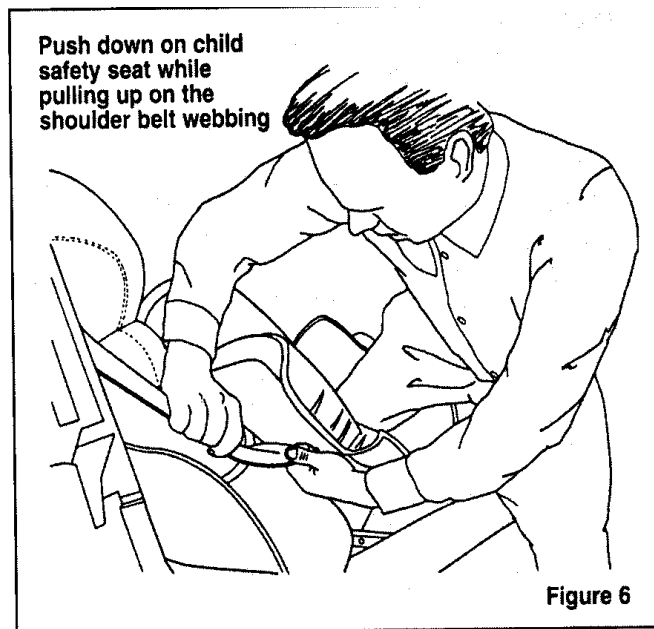
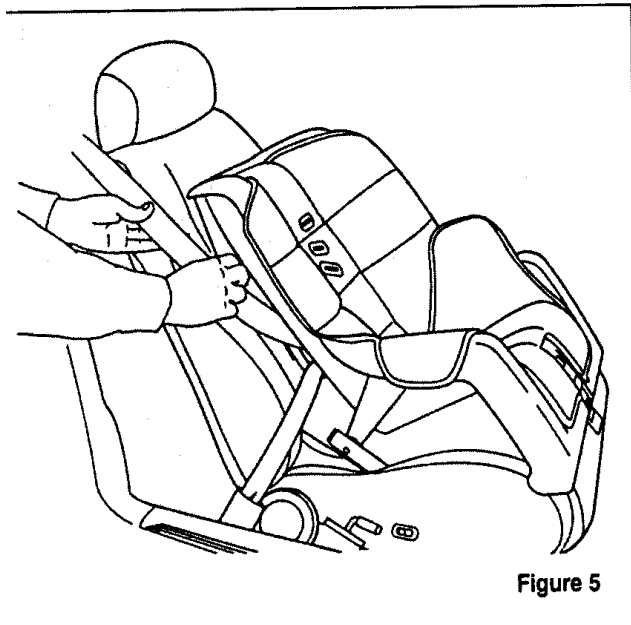

Figure 4

Setting the retractor to automatic locking mode

6. Allow the belt to retract. A clicking sound will be heard as the belt retracts. This indicates the retractor is in the automatic locking mode. Pull on the lap belt portion across the child seat towards the buckle and continue to pull up on the shoulder belt portion while pushing down on the child seat allowing the shoulder belt to retract to remove any slack in the seat belt. See Figures 5 and 6.



7. Before placing the child in the child seat, forcibly tilt the seat from side to side and in forward directions to make sure that the seat is securely held in place. See Figure 7.

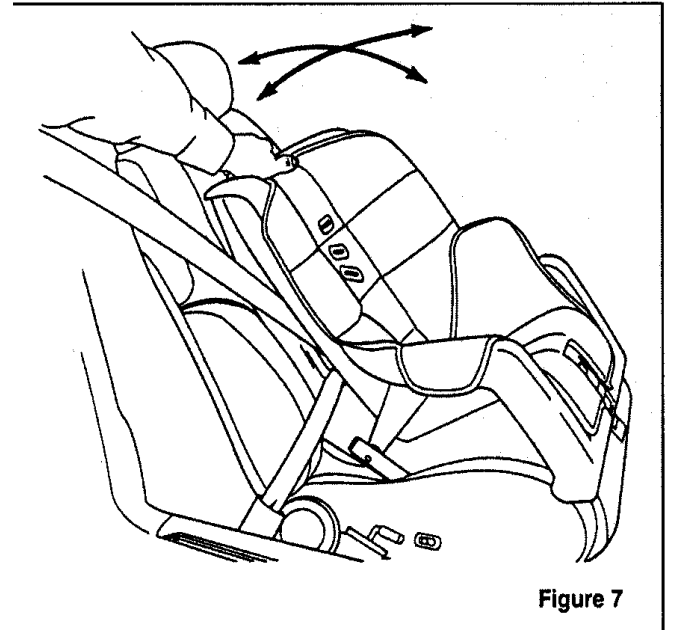

Figure 7

Checking that the seat is secure

8. Double check that the retractor is in the automatic locking mode. Try to pull more belt out of the retractor. If you cannot, the belt is in the automatic locking mode. See Figure 8.

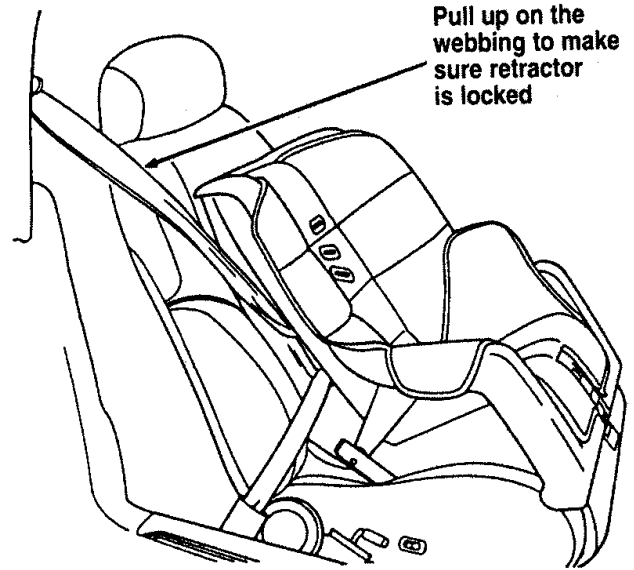

Figure 8

Checking the retractor

9. Check to make sure that the child seat is properly secured prior to each use. If the retractor is not locked, repeat steps 6 through 8.

NOTE: To remove the retractor from automatic lock mode, allow seat belt to retract fully to its stowed position and the retractor will automatically switch back to the vehicle sensitive locking mode for normal adult usage.

Installing a Child Safety, Seat at the Front Center Seating Position with Adjustable Lap Belt-

1. Lengthen the lap belt. To lengthen the belt, hold the tongue so that its bottom is perpendicular to the direction of webbing while sliding the tongue up the webbing.
2. Place the child safety seat in the center seating position.

3. Route the tongue and webbing through the child seat according to the child seat manufacturer's instructions.
4. Insert the belt tongue into the proper buckle for the center seating position until you hear a snap and feel it latch. Make sure the tongue is m securely fastened to the buckle by pulling on tongue.
5. Push down on the child seat while pulling on the loose end of the lap belt webbing to tighten the belt.
6. Before placing the child into the child seat, forcibly tilt the child seat from side-to-side and in forward directions to ensure that the seat is held securely in place. If the child seat moves excessively, repeat steps 5 through 6, or properly install the child seat in a different seating position.

/! WARNING

Carefully follow all of the manufacturer's instructions included with the safety seat you put in your vehicle. If you do not install and use the safety seat properly, the child may be injured in a sudden stop or collision.

Attaching Safety Seats With Tether Straps

Some manufacturers make safety seats that include a tether strap that goes over the back of the vehicle seat and attaches to an anchoring point. Other manufacturers offer the tether strap as an accessory. Contact the manufacturer of your child safety seat for information about ordering a tether strap.

Tether anchorage hardware

All vehicles include a tether anchor installed at the rear center seating position for use with child safety seats. Attachment holes (at each rear outboard

seating position) have been provided in your vehicle to attach anchor hardware, if required. Additional kits can be obtained at no charge from any Ford or Lincoln-Mercury dealer.

Safety Belts for Children

Children who are too large for child safety seats should always wear safety belts. (See instructions with your child seat, or contact its manufacturer, to determine maximum size of child that will safely fit in the seat.)

/! WARNING

If safety belts are not properly worn and adjusted as described, the risk of serious injury to the child in a collision will be much greater.

If the shoulder belt portion of the lap/shoulder belt can be positioned so that it does not cross or rest in front of the child's face or neck, the child should wear the lap/shoulder belt. Moving the child closer to the seat belt buckle may help provide a good shoulder belt fit.

To improve the fit of lap and shoulder belts on children who have outgrown child safety seats, Ford recommends use of a belt-positioning booster seat that is labelled as conforming to all Federal motor vehicle safety standards. Belt-positioning booster seats raise the child and provide a shorter, firmer seating cushion that encourages safer seating posture and better fit of lap and shoulder belts on the child. A belt-positioning booster should be used if the shoulder belt rests in front of the child's face or neck, or if the lap belt does not fit snugly on both thighs, or if the thighs are too short to let the child sit all the way back on the seat cushion when the lower legs hang over the edge of the seat cushion. You may wish to discuss the specific needs of your child with your pediatrician.

! WARNING

Do not use a belt-positioning booster with a lap-only belt.

Lap belts and the lap belt portion of lap and shoulder belts should always be worn snugly and below the hips, touching the child's thighs.

! WARNING

To reduce the risk of serious injury in collision, children should always ride with the seatback upright.

Starting Your Continental

Ignition

Understanding the Positions of the Ignition

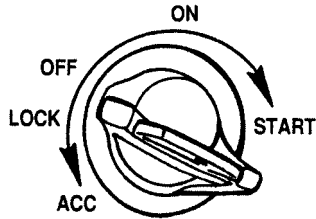

The positions of the key in the ignition

ACCESSORY allows some of your vehicle's electrical accessories such as the radio and the windshield wipers to operate while the engine is not running.

NOTE: Your vehicle is also equipped with an accessory timer. This allows some of your accessories to remain on for up to 10 minutes after the ignition is turned to the OFF position. The accessory timer is cancelled if any door is opened, the dimmer switch is used, or the ignition is turned to the ON position.

The automatic transaxle gearshift must be in P (Park) to move the key to the LOCK position.

LOCK locks the steering wheel. It also locks the gearshift lever.

LOCK is the only position that allows you to remove the key. The LOCK feature helps to protect your vehicle from theft.

OFF allows you to shut off the engine and all accessories without locking the steering wheel, or the gearshift lever.

ON allows You to test your vehicle's warning lights (except the brake system warning light) to make sure they work before you start the engine. The key returns to the ON position once the engine is started and remains in this position while the engine runs.

START cranks the engine. Release the key once the engine starts so that you do not damage the starter. The key should return to ON when You release it. The START position also allows You to test the Brake Warning Light.

Removing the Key From the Ignition

1. Put the gearshift in P (Park)-
2. Set the parking brake fully.
3. Turn the ignition key to LOCK.
4. Remove the key.

If the key is stuck in the LOCK position, move the steering wheel left or right until the key turns freely.

If the driver's door is open while the key is still in the ignition, a warning chime sounds.

!/\ WARNING

Always set the parking brake fully and make sure that the gearshift is securely latched in P (Park).

!/\ WARNING

Do not leave children, unreliable adults, or pets alone in your vehicle. They could accidentally injure themselves or others through inadvertent operation of the vehicle. Further, on hot, sunny days, temperatures in a closed vehicle could quickly become high enough to cause severe and possibly fatal injuries to people as well as animals.

Fuel-Injected Engines

When starting a fuel-injected engine, **the most important thing to remember is to avoid pressing down on the accelerator before or during starting.** Only use the accelerator when you have problems getting your vehicle started. See *Starting Your Engine* in this chapter for details about when to use the accelerator while you start your vehicle.

Starting Your Vehicle

Preparing to Start Your Vehicle

!/\ WARNING

Do not start your vehicle in a closed garage or other enclosed area. Never sit in a stopped vehicle for more than a short period of time with the engine running. Exhaust fumes are toxic. See *Guarding Against Exhaust Fumes* in this chapter for more instructions.

Before you start your vehicle, do the following:

1. Make sure you and all your passengers buckle your safety belts. See *Safety Restraints* in the Index for more details.
2. Make sure the headlamps and other accessories are turned off when starting.

3. Make sure that the gearshift is in P (Park) and the parking brake is set before you turn the key.

Before you start your vehicle, you should test the warning lights on the instrument panel to make sure that they work. Refer to the *Warning Lights and Gauges* chapter.

Starting Your Engine

To start your engine:

1. Follow the steps under *Preparing to Start Your Vehicle* at the beginning of this section.
2. Turn the ignition key to the ON position.
3. DO NOT depress the accelerator pedal when starting your engine. DO NOT use the accelerator while the vehicle is parked.

4. Turn the key to the START position (cranking) until the engine starts. Allow the key to return to the ON position after the engine has started.

If you have difficulty in turning the key, rotate the steering wheel slightly because it may be binding.

For a cold engine:

- At temperatures **10°F (-12°C) and below**: If the engine does not start in **fifteen (15) seconds** on the first try, turn the key to OFF, wait approximately ten (10) seconds so you do not flood the engine, then try again.
- At temperatures **above 10°F (-12°C)**: If the engine does not start in **five (5) seconds** on the first try, turn the key to OFF, wait approximately ten (10) seconds so you do not flood the engine, then try again.

For a warm engine:

- Do not hold the key in the START position for more than **five (5) seconds at a time**. If the engine does not start within five (5) seconds on the first try, turn the key to the OFF position. Wait a few seconds after the starter stops, then try again.

Whenever you start your vehicle, release the key as soon as the engine starts. Excessive cranking could damage the starter or flood the engine.

After you start the engine, let it idle for a few seconds. Keep your foot on the brake pedal and put the gearshift lever in gear. Release the parking brake. Slowly release the brake pedal and drive away in the normal manner.

NOTE: Your vehicle is equipped with an automatic transaxle that has an interlock that prevents you from shifting out of P (Park) unless your foot is on the brake pedal.

If the engine does not start after two attempts:

1. Turn the ignition key to the OFF position
2. Press the accelerator all the way to the floor and hold it.
3. Turn the ignition key to the START position,
4. Release the ignition key when the engine starts
5. Release the accelerator gradually as the engine speeds up. Then drive away in the normal manner.

If the engine still does not start, the fuel pump shut-off may have been triggered. For directions on how to reset the switch see Fuel Pump Shut-Off Switch later in this chapter.

A computer system controls the engine's idle speed. When you start your vehicle, the engine's idle speed normally runs higher than when it is warmed up. These faster engine speeds will make your vehicle move slightly faster than its normal idle speed. It should, however, slow down after a short time. If it does not, have the idle speed checked.

If the engine idle speed does not slow down automatically, do not allow your vehicle to idle for more than 10 minutes. Have the vehicle checked.

!/\ WARNING

Extended idling at high engine speeds can produce very high temperatures in the engine and exhaust system, creating the risk of fire or other damage.

!/\ WARNING

Do not park, idle, or drive your vehicle in dry grass or other dry ground cover. The emission system heats up the engine compartment and exhaust system, which can start a fire.

Engine Block Heater (If equipped)

Engine block heaters are strongly recommended if you live in a region where temperatures reach -10°F (-23°C) or below. An engine block heater warms the engine coolant, which improves starting, warms up the engine faster, and allows the heater-defrost system to respond quickly.

To turn the heater on, simply plug it into a grounded 110-volt outlet. Ford recommends that you use a 110-volt circuit that is protected by a ground fault circuit interrupter.

⚠ WARNING

To prevent electrical shock, do not use your heater with ungrounded electrical systems or two-pronged (cheater) adapters.

For best results, plug the heater in at least three hours before you start your vehicle. Using the heater for longer than three hours will not damage the engine, so you can plug it in at night to start your vehicle the following morning.

If the Engine Cranks but Does Not Start After a Collision

Fuel Pump Shut-off Switch

If the engine cranks but does not start or does not start after a collision, the fuel pump shut-off switch may have been triggered. The shut-off switch is a device intended to stop the fuel pump when your vehicle has been involved in a substantial jolt.

Once the shut-off switch is triggered, you must reset the switch by hand before you can start your vehicle. The switch is on the left side of the trunk.

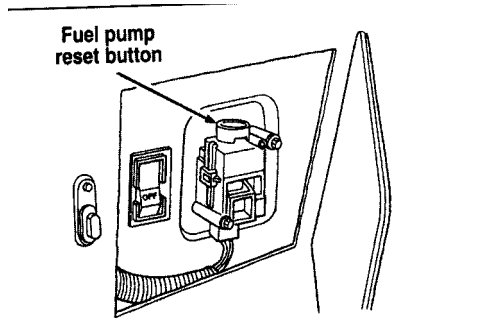

The left side of the trunk

/!\ WARNING

If you see or smell fuel, do not reset the switch or try to start your vehicle. Have all the passengers get out of the vehicle and call the local fire department or a towing service.

If your engine cranks but does not start after a collision or substantial jolt:

1. Turn the ignition key to the OFF position.
2. Check under the vehicle for leaking fuel.
3. If you do not see or smell fuel, push the red reset button down. If the button is already set, you may have a different mechanical problem.
4. Turn the ignition key to the ON position for a few seconds, then turn it to the OFF position.
5. Check under the vehicle again for leaking fuel. **If you see or smell fuel, do not start your vehicle again.** If you do not see or smell fuel, you can try to start your vehicle again.
6. Check all vehicle warning lights before driving the vehicle.

Pushing

Vehicles with automatic transaxles cannot be started by pushing. Follow the directions under *If Your Vehicle Needs a Jump-Start* in the *Roadside Emergencies Chapter*.

Guarding Against Exhaust Fumes

Carbon monoxide, although colorless and odorless, is present in exhaust fumes. Take precautions to avoid its dangerous effects.

⚠️WARNING

Do not start your vehicle in a closed garage or other enclosed area. Never sit in a stopped vehicle for more than a short period of time with the engine running. Exhaust fumes are toxic. See *Guarding Against Exhaust Fumes* in this chapter for more instructions.

⚠️WARNING

If you smell exhaust fumes inside your vehicle, have your dealer inspect your vehicle immediately. Do not drive if you smell exhaust fumes.

Have the exhaust and body ventilation systems checked whenever:

- your vehicle is raised for service
- the sound of the exhaust system changes
- your vehicle has been damaged in a collision

Improve your ventilation by keeping all air inlet vents clear of snow, leaves, and other debris.

If the engine is idling while you are stopped in an open area for long periods of time, open the windows at least one inch (2 . 5 cm). Also, adjust the heating or air conditioning to bring in outside air.

If you use the Electronic Automatic Climate Control, set the fan speed selector dial to a medium or high blower speed with the VENT or PNL-FLR function buttons pressed.

Warning Lights and Gauges

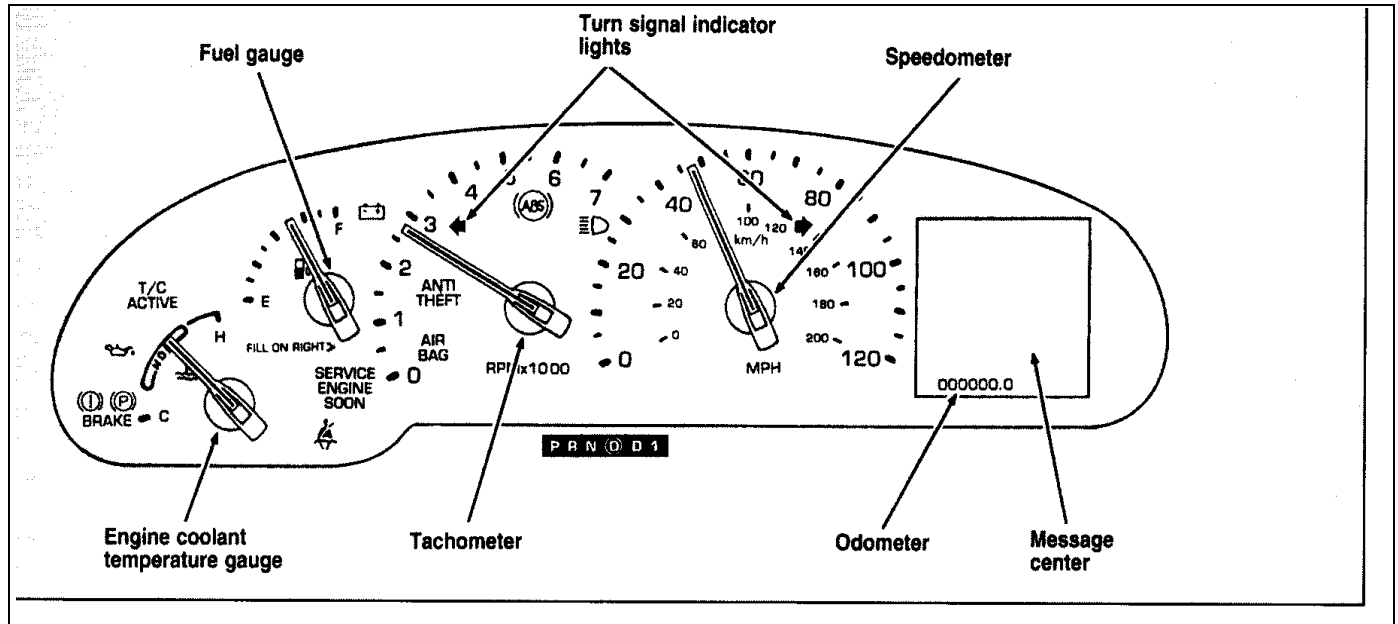

Instrument cluster

The following warning lights and gauges are on the instrument cluster. AD of the warning lights and gauges alert you to possible problems with your vehicle.

Indicator Lights and Chimes

Safety Belt Warning Light and Chime

This warning light and chime remind you to fasten your safety belt. The following conditions will take place:

- If the safety belt is not buckled when the ignition is turned to the ON position, the chime will turn on for four (4) to eight (8) seconds and the light will come on for one to two minutes.
- If the safety belt is buckled while the light is on and the chime is sounding, both the light and chime will turn off.

- If the **safety belt** is **buckled before the** ignition is turned to the **ON** position, neither the light nor the chime will come on.



Brake System Warning Light

The warning light for the brakes can show two things - that the parking brake is not fully released, or that the brake fluid level is low in the master cylinder reservoir. If the fluid level is low, the brake system should be checked by your dealer or a qualified service technician.

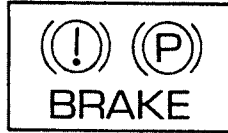

This light comes on when the parking brake is set, or if it is not set, it comes on briefly when you turn the ignition to the START position. It normally goes off shortly after the engine starts and you release the parking brake. If the light stays on after you have fully released the parking brake, have the hydraulic brake system serviced by your dealer or a qualified service technician.

!WARNING

The BRAKE light indicates that the brakes may not be working properly. Have the brakes checked immediately.

Anti-Lock Brake System Warning Light

This light comes on for a few seconds when you turn the ignition key to the START position. It should go off shortly after the engine starts. If it stays on longer than five (5) seconds, it indicates that your anti-lock brake system may not be working properly. Normal braking is not affected unless the BRAKE system warning light also remains on for longer than six (6) seconds. You should have your vehicle serviced immediately by your dealer or qualified service technician to restore the benefits of the anti-lock feature. See *Anti-lock brakes* in the Index for more information.



Engine Oil Pressure Warning Light

This light indicates the engine's oil pressure, not the oil level. However, if your engine's oil level is low, it could affect the oil pressure. The light will come on briefly when you turn your key to the START and ON position. The light should stay off when the engine is running with normal oil pressure. If the light comes on while the engine is running, you have lost oil pressure and continued operation will cause severe engine damage.

If you lose engine oil pressure:

1. Pull off the road as soon as safely possible.
2. Shut off the engine immediately or severe engine damage could result.
3. Check the engine's oil level, following the instructions on checking and adding engine oil, see the *Engine Oil* in the Index. If you do not follow these instructions, you or others could be injured. To assure an accurate reading, your car should be on level ground.
4. If the level is low, add only as much oil as necessary before you start the engine again. Do not overfill. Do not operate the engine if the light is on, regardless of the oil level. Contact your nearest dealer for further service actions.

For more information about adding oil, see *Adding engine oil* in the *Servicing Your Vehicle* chapter.

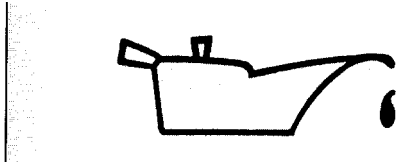

Traction Control® Active Light (If equipped)

This light comes on when the Traction Control® system begins applying and releasing the brakes and adjusting the engine characteristics to limit a wheelspin condition.

It will be lit for a minimum of six seconds or for the duration of the Traction Control® event.



Charging System Light

This light indicates that your battery is not being charged and that you need to have the electrical system checked.



This light comes on every time you turn the ignition to the ON or START position (engine off). The light should go off when the engine starts and the alternator begins to charge.

If the light stays on or comes on when the engine is running, have the electrical system checked as soon as possible.

Turn Signal Indicator Lights

When you push the turn signal lever up before making a right turn, the right side arrow on the instrument panel flashes.

When you push the turn signal lever down before making a left turn, the left side arrow on the instrument panel flashes.

Usually, the turn signals turn off automatically after you turn your car. If the turn signal continues to flash after you have made the turn, push the lever back to the OFF position.



If one or both of your turn indicators do not flash or stay on continuously, have them serviced as soon as possible. In the meantime, be sure to use the accepted hand signals.

Service Engine Soon Warning Light

The Powertrain On-Board Diagnostic 11 (OBD 11) system consists of the hardware and software necessary to monitor the operation of the powertrain. The OBD 11 system is designed to check the function of the vehicle's powertrain control system during normal operation. If an emission problem is detected, the Service Engine Soon light (in the cluster) is turned on.

Modification or additions to the vehicle may cause incorrect operation of the OBD 11 system. Additions such as burglar alarms, cellular phones, and CB radios must be carefully installed. Do not install these devices by tapping into or running wires close to powertrain control system wires or components.



The light comes on briefly when you turn the ignition to the **ON** position, but should turn off when the engine starts. If the light does not come on when you turn the ignition to the **ON** position or if it comes on and stays on when you are driving, have your vehicle serviced as soon as conveniently possible.

This indicates a possible problem with one of the vehicle's emission control systems. You do not need to have your vehicle towed in.

If the light turns on and off at one second intervals while you are driving the vehicle, it means that the engine is misfiring. If this condition persists, damage could occur to the engine or catalytic convertor. Have your vehicle serviced at the first opportunity.

If the light turns on and off on rare occasions while you are driving, it means that a malfunction occurred and the condition corrected itself.

An example of a condition which corrects itself occurs when an engine running out of fuel begins to misfire. In this case, the Service Engine Soon Light may turn on and will then set a diagnostic trouble code indicating that the engine was misfiring while the last of the fuel was being consumed. After refueling, the Service Engine Soon Light will turn off after the vehicle has completed three consecutive warm up cycles without a misfire.

condition occurring. A warm up cycle consists of engine start from a cold condition (engine at ambient temperature) and running until the engine reaches normal operating temperature.

On the fourth engine start up, the Service Engine Soon light will turn off as soon as the engine begins to crank. It is not necessary to have the engine serviced.

Under certain conditions, the Service Engine Soon Light may come on if the fuel cap is not properly installed. If the Service Engine Soon Light comes on and you suspect that the fuel cap is not properly installed, pull off the road as soon as it is safely possible and turn off the engine. Remove and replace the cap, making sure it is properly seated.

After completing the three consecutive warm up cycles and on the fourth engine start up, the Service Engine Soon Warning Light should turn off. If the light does not go off after the fourth engine re-start, have your vehicle serviced by your dealer or a qualified technician.

High Beam Light

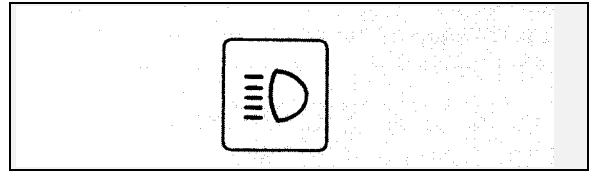

This light comes on when the headlamps are turned to high beam or when you flash the lights.

Chime for Headlamps On

This chime sounds if the driver or any passenger door is open when the parking lamps or headlamps are on. The chime sounds until you close the door, turn off the lamps or turn the ignition to the ON position.

Air Bag Readiness Light

The air bag system uses a readiness light and a tone to indicate the condition of the system. The readiness light is in the instrument cluster. When you turn the ignition key to the ON position, this light will light up for six (6) seconds and then turn off. This indicates that the system is operating normally. **NOTE:** Regularly scheduled maintenance of the air bag system is not required.



If the light fails to illuminate, continues to flash, remains on, or you hear a beeping sound, have the system serviced at your Ford or Lincoln-Mercury dealer immediately.

Anti-Theft Alarm Light (If equipped)

This light flashes on and off when the ignition is turned to the OFF position and any door is opened. As soon as you lock the doors, the light glows steadily. Within 30 seconds of closing all the doors, the light goes out. This indicates that the alarm system is armed.



See Anti-Theft System in the Features chapter for more information.

The Instrument Cluster

In addition to warning lights, the instrument cluster has a message center/odometer, a speedometer, tachometer, fuel and coolant temperature gauges.

The Electronic Message Center (M/C)

The Electronic Message Center only works when the ignition is in the ON position.

Each time the WC is powered the display goes through a self test by displaying the PLEASE FASTEN SEATBELT message. This self test is used to stabilize the systems before reporting the status to you.

The message center tells you about the condition of your vehicle by two methods:

- operator selectable features
- continuous warning reporting of monitored systems

You can select different features for the M/C to display by using the message center control buttons located to the right of the instrument cluster. You will hear a tone when you press one of these buttons. However, if the M/C detects a warning from any of the monitored systems, then the M/C will display the appropriate warning message.

Operator Selectable Features

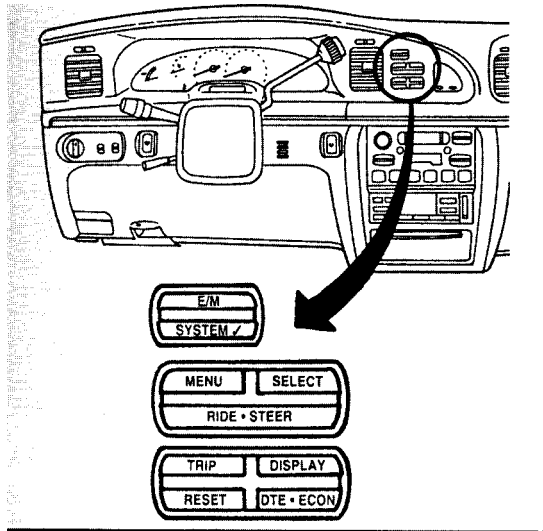

Cluster Control Buttons and Message Center Control Buttons

These features are controlled by the message center control buttons located to the right of the instrument cluster.

System Check

Pressing the SYSTEM CHECK button causes the M/C to cycle through a status of each of the systems being monitored. For each of the monitored systems, the M/C will indicate either an OK message or a warning message for three seconds. The sequence of the system check report is as follows:

- Washer Fluid Level
- Ride Control
- Oil Level
- Engine Coolant Level
- Voltage Level
- Engine Temperature

- Doors Closed Trunk Closed
- Trunk Closed
- Exterior Lamps
- Distance to Empty
- Fuel Level
- Traction Control (if equipped)

System Warnings

System warnings alert you to possible problems or malfunctions in your vehicle's operating systems. There are up to 18 warning messages which can be displayed by the M/C to show the status of the monitored systems. The M/C will display the last selected feature if there are no more warning messages. This allows you to use the full functionality of the M/C after you acknowledge the warning by pressing the RESET button and clearing the warning message.

WARNING	ACT10N
Door Ajar Driver's Door Ajar Check Engine Temp Check Charging System Low Fuel Level Low Engine Coolant Low Oil Level Low Tire Pressure (if equipped)	Warning returns after 10 minutes
Headlamp Out Brake Lamp Out Check Traction Control (if equipped) Check Ride Control Trunk Ajar Check Steering Assist Low Washer Fluid Air Leveling Disabled Tail lamp Out Front Turn Lamp Out	Warning reappears after key is turned from OFF to ON

Warning messages that have been reset are divided into two categories. They will reappear on the display ten minutes from the reset or they will not reappear until an ignition OFF-ON cycle has been completed. This reappearing of warning messages is a reminder that these warning conditions still exist within the vehicle.

EIM

A press of this button allows you to change the M/C and the Electronic Climate control unit from English to Metric Units. When you press this button all displays change from English to Metric or Metric to English units. The displays remain in the units you have chosen until you change them again even after you turn off the vehicle and start it again.

TRIP

Pressing this button will display the first of two trip odometers. Pressing it again will display the second Trip Odometer. Pressing RESET will clear only that Trip odometer which is displayed.

DTE/ECON

Pressing this button a first time will display approximately how many miles you can drive before you run out of fuel, or in other words the Distance To Empty (DTE). To ensure accuracy, turn the ignition OFF when you fill the tank.

Pressing this button a second time will allow you to display your Average Fuel Economy in miles/gallon or Uters/100 kilometers. Your WC computes this figure using the distance traveled and rate of fuel used information. If you want to reset this feature, press the RESET button while the Average Fuel Economy feature is displayed.

NOTE: DTE (Distance to Empty) is calculated using a "Running Average Fuel Economy" initialized by the factory. This value is not the same as the Average Fuel Economy Display. The Running Average Economy is based on more than 500 miles (800 km) of driving history. Also the factory default for Running Average Economy is reinitialized if the battery is disconnected.

If the FUEL LEVEL ERROR message is displayed this means that there is a problem with the fuel indication system and you should contact your dealer for service as soon as possible.

RESET

A press of the RESET button will allow you to reset the current feature displayed. Warnings, Average Fuel Economy, and Trip odometers are the only features which respond to the RESET button. Distance to Empty (DTE), RIDE/STEER and MENU are unaffected by pressing the RESET switch.

DISPLAY

Pressing this button will cause the message center display to turn off. Pressing it again will cause the display to come on again. Warnings override an off display and must be reset in order for the display to be off again.

RIDE/STEER

Pressing this button once will allow you to adjust your RIDE CONTROL settings, between NORMAL, PLUSH and FIRM. The settings are changed by pressing the SELECT button while RIDE CONTROL is displayed.

Pressing the RIDE/STEER button a second time will allow you to adjust the STEERING EFFORT settings between NORMAL, LOW, and HIGH. The settings are changed by pressing the SELECT button while STEERING EFFORT is displayed.

NOTE: The combination of FIRM RIDE CONTROL and LOW STEERING EFFORT is undesirable and cannot be selected.

MENU

Pressing this button will allow You to change various convenience settings throughout the vehicle. The settings for each feature are changed **by** pressing the SELECT button-

Pressing the MENU button once will allow you to enable or disable the EXPRESS WINDOW feature. This feature allows one tap down operation on the driver's window using the window switch on the driver's door armrest.

Pressing MENU again will allow you to enable or disable the AUTO DOOR LOCK feature. This feature automatically locks all doors when the driver shifts out of PARK, all doors are closed, the driver's seat is occupied, and the vehicle is traveling over three mph (5 km/h).

Pressing MENU again will allow you to enable or disable the HORN CHIRP feature. When HORN CHIRP is ON the horn will briefly sound when the Remote Entry Key Fob LOCK button is pressed. This verifies the doors have been locked and the ANTI-THEFT system has been armed (if equipped).

Pressing MENU again will allow you to enable or disable the SEAT ACCESS feature. When ON, the driver's seat will move back 2 inches (5 cm) or to

end of seat track travel when the vehicle is turned off and the ignition key is removed. Upon the driver entering the vehicle and closing the door, the seat will move forward to its previous position.

Pressing MENU again will allow you to enable or disable the REVERSE MIRRORS feature. When ON, the outside rearview mirrors tilt down when the gearshift is placed in R (Reverse). This provides for an improved view of the side of the vehicle and curb area when backing up. When you shift out of REVERSE the mirrors return to their previous positions.

Odometer

The odometer tells you the total number of miles (kilometers) your vehicle has been driven.

If the odometer displays the word Error, please contact your dealer for service.

Speedometer

The speedometer tells you how many miles (kilometers) per hour your vehicle is moving.

Tachometer

The tachometer displays the approximate engine revolutions per minute (rpm), or how fast the engine is running.

You can drive your vehicle at most rpm points on the tachometer but you must stay out of the red zone.

If you drive with the tachometer in the red zone, you may damage the engine.

Engine Coolant Temperature Gauge

This gauge indicates the temperature of the engine coolant, not the coolant level. If the coolant is not at its proper level or mixture, the gauge indication will not be accurate.

The pointer moves from the C (cold) mark into the NORMAL band as the engine coolant warms up. It is acceptable for the pointer to fluctuate within the NORMAL band under normal driving conditions.

Under certain driving conditions such as, heavy stop and go traffic, or driving up hills in hot weather, the pointer may indicate at the top of the NORMAL band.

If, under any circumstances, the pointer moves above the NORMAL band, the engine coolant is overheating and continued operation may cause engine damage.

If your engine coolant overheats:

1. Pull off the road as soon as it is safely possible.
2. Turn off the engine.
3. Let the engine cool. **DO NOT REMOVE COOLANT SYSTEM FILL CAP UNTIL THE ENGINE IS COOL.**

4. Check the coolant level following the instructions on checking and adding coolant to your engine, see the **Engine Coolant** in the Index. If you do not follow these instructions, you or others could be injured.

If the coolant continues to overheat, have the coolant system serviced as soon as possible.

Fuel Gauge

The fuel gauge displays approximately **how** much fuel you have in the fuel tank. The ignition switch must be in the OFF position while filling **the** tank with at least three gallons (11 liters) for **the fuel** gauge to indicate the new level. If the ignition is left ON or less than **3** gallons (11 liters) **of fuel** are added the fuel gauge will not immediately indicate the new fuel level. The gauge will gradually correct itself to indicate the true fuel level.

Overhead Console Warnings

If your Continental is equipped with the Pressure Alert System, a warning will appear in the overhead console when the pressure in one of your vehicle's tires drops below acceptable levels or if the system has malfunctioned.



**LOW TIRE
PRESSURE**

See Securities in the *Features* chapter for more information.

Lincoln RESCU System (If equipped)

Lincoln RESCU runs a self-test when you start your vehicle. During this test, the Lincoln RESCU warning light, located in the overhead console, will briefly illuminate. If a problem is detected during the self-check, the light will remain lit and the message "RESCU FAILURE" will be displayed on the vehicle's message center for several seconds.

If the warning light fails to briefly illuminate when you start your vehicle or if it remains lit, have your Lincoln RESCU System checked by an authorized Lincoln/Mercury dealer as soon as possible. Your system may be inoperative.

Instrument Panel Controls

The instrument panel (dashboard) on your vehicle is divided into several different sections. The illustrations on the following pages show the major parts of the instrument panel that are described in this chapter. Some items shown may not be on all vehicles.

The main controls for the climate control system, clock, and radio are on the instrument panel.

If you have radio transmitting equipment in your vehicle, be aware that it can interfere with your vehicle's electrical system and may cause the instrumentation and/or convenience products to have temporary, abnormal operation.

NOTE: Any cleaner or polish that increases the gloss (shine) of the upper part of the instrument panel should be avoided. The dull finish in this area is to help protect the driver from undesirable windshield reflection.

Clean the instrument panel lens and woodtone trim with a soft cloth and a glass cleaner. Do not use paper towel or any abrasive cleaner to clean either the lens or the woodtone trim as these may cause scratches.

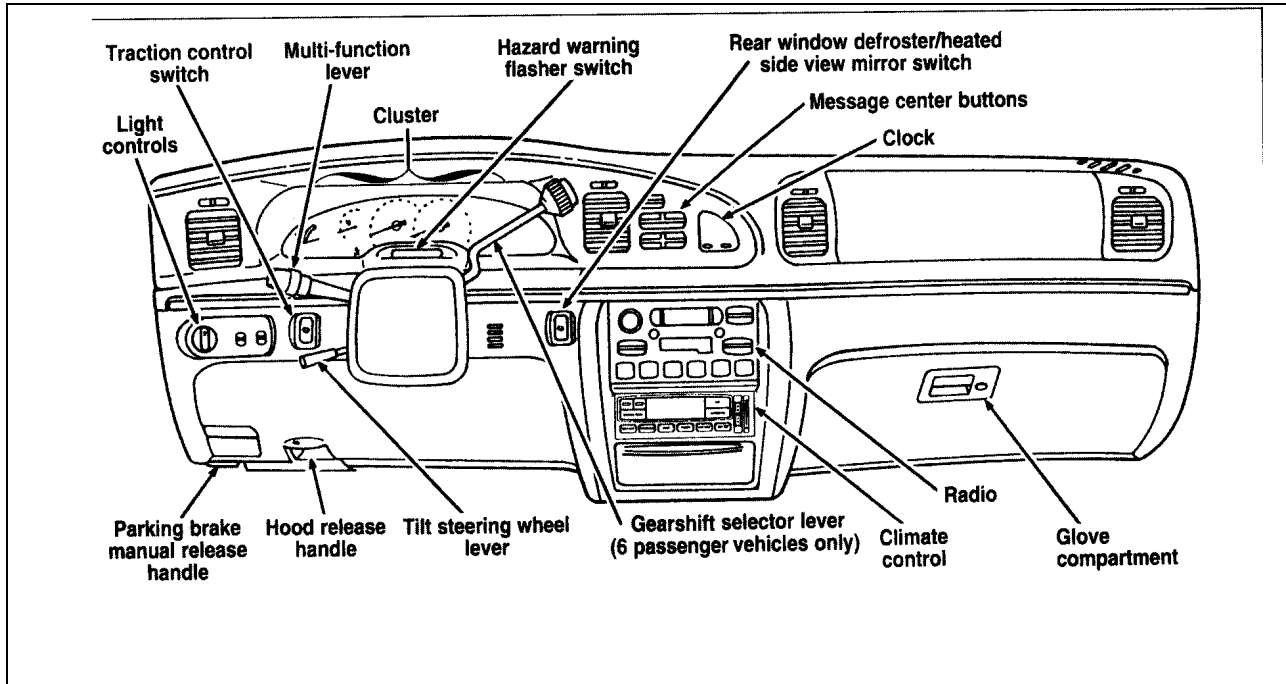

Instrument panel

The Climate Control System

Electronic Automatic Temperature Control System

The control for your Electronic Automatic Temperature Control (EATC) is located at the center of the instrument panel and operates only when the key is in the ON position.

The EATC feature maintains the temperature you select and automatically controls the airflow for your comfort. It also allows you to override the automatic operation with manual override buttons.

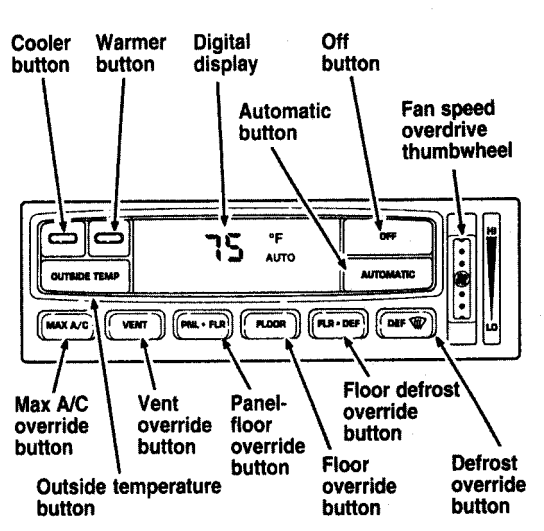

The automatic temperature control system

To turn your EATC on, push the AUTOMATIC button or any of the six override buttons along the bottom of the control.

To turn your EATC off, press the OFF button. When the system is off, the display window will be blank (dark) except when OUTSIDE TEMP has been selected. Then, OUTSIDE TEMP and the temperature will appear in the window.

If you select AUTOMATIC, the system will automatically determine fan speed and airflow location. If an override button is selected, your selection determines airflow location only. Fan speed remains automatic unless you override it by rotating the vertical thumbwheel located at the extreme right of the control panel.

To change the temperature in the display window, select any temperature between 65°F (19°C) and 85°F (29°C) using the BLUE (cooler) or RED (warmer) buttons. The Electronic Automatic Temperature Control will do the rest.

If you want continuous maximum cooling, push the BLUE button until 60°F (16°C) is shown in the display window. Your EATC will cool at maximum and disregard the 60°F (16°C) setting until you select a warmer temperature with the RED button. If you want continuous maximum heating, push the RED button until 90°F (32°C) is shown in the display window. Your EATC will provide maximum heat regardless of the 90°F (32°C) setting until you select a cooler temperature with the BLUE button.

The display window tells you how the system is operating. It will indicate the selected temperature and the operating function you have chosen; AUTO or one of the six manual overrides. It will also indicate manual (thumbwheel) control of the fan speed with the  symbol. The display window with all possible displays and their positions are shown here. Normally not all are shown at the same time but are included here to familiarize you with the names and symbols.

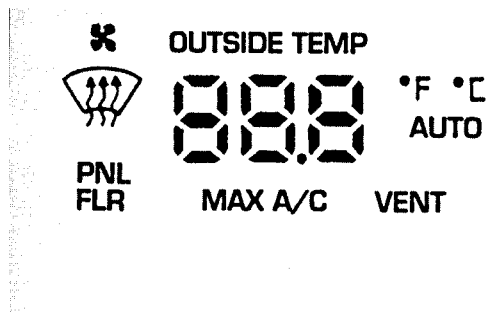

The display window

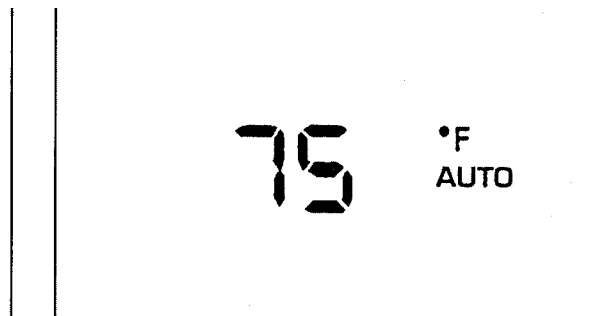

The AUTO temperature display

Automatic operation

Push the AUTOMATIC button and select the desired temperature. The selected temperature and AUTO will be shown in the display window. The EATC will automatically heat or cool to achieve the set temperature. Under normal conditions, your EATC will need no additional attention.

When in AUTOMATIC and weather conditions require heat, air will be sent to the floor. But, a feature is included in your EATC to prevent blowing cold air to the floor if the engine coolant is not warm enough to allow heating. In 3-1/2 minutes or less, the fan speed will start to increase and the airflow will change to the floor area.

If unusual conditions exist (i.e., window fogging, etc.), the six manual override buttons allow YOU to select special air discharge locations. A thumbwheel allows you to adjust the fan speed to suit your needs.

Temperature selection

The RED and BLUE buttons at the upper left of the Control are for temperature selection. The RED Button will increase the set temperature and the BLUE Button will lower the set temperature. Pressing a button and releasing it will change the set temperature one degree. Holding either button in will rapidly change the temperature setting in one degree increments to either 65°F (18°C) (BLUE) or 85°F (29°C) (RED). Then, the set temperature will jump 5° and stop at either 60°F (16°C) which is maximum cooling or 90°F (32°C) which is maximum heating. When you select 60°F (16°C) or 90°F (32°C), the fan will go to HI speed for maximum air flow.

The average temperature range used is between 68°F (20°C) and 78°F (26°C). Changing the temperature setting by several degrees outside this range or overriding to 60°F (16°C) or 90°F (32°C) will not speed up the heating or cooling process.

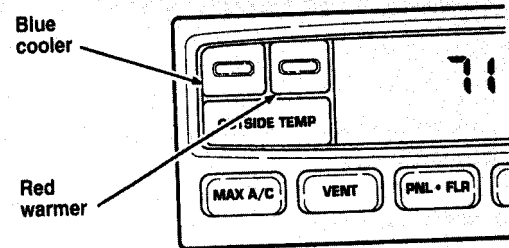

Fan speed and thumbwheel

Your EATC automatically adjusts the fan speed to the existing conditions. You must push **AUTOMATIC** for automatic fan speed operation. To control the fan speed yourself, use the thumbwheel which will cancel the automatic fan speed control. The thumbwheel is located at the extreme right side of the EATC control panel. It is a vertical control marked with a fan symbol. Rotate up for **HI** and down for **LO** speeds.

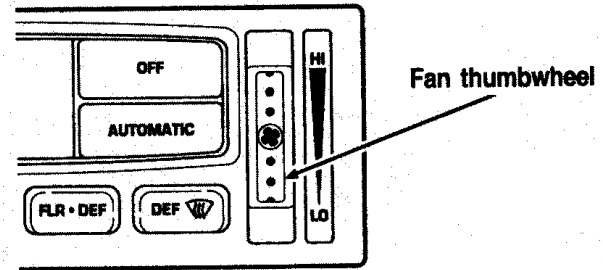

When you move the thumbwheel, the fan speed will go to manual control. The display window will show the  symbol in the lower right corner along with the selected temperature and operating function.

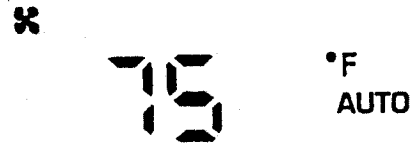

You can override the fan speed at any time. If you use the thumbwheel to override the fan speed, the EATC will continue to control the temperature but you control the fan speed. To return to auto fan control, press the AUTOMATIC button. If you are operating in one of the override functions (FLOOR, MAX A/C, etc.), automatic fan control will continue unless you rotate the fan thumbwheel. To

return to automatic fan control, press the AUTOMATIC button. The EATC will return to Automatic operation. If you want to return to any override function, press the button for that function. The fan speed will continue to be automatically controlled.

Manual override buttons

Your EATC has six buttons which allow you to make special selections. The buttons are located along the bottom edge of the EATC control and allow you to determine where the air will be discharged. Pressing any override button changes the air discharge location only. It does not affect the ability of the system to control temperature or the fan speed. Return to fully Automatic operation by pushing the AUTOMATIC button.

MAX A/C button

The MAX A/C feature allows for faster cooling because air is drawn from inside the vehicle. Using inside air causes the fan to sound louder which is normal for this selection. The Display window will change to indicate 60°F (16°C) and MAX A/C. The fan will run at high speed and the airflow will be from the instrument panel registers. To exit and return to the previous temperature, push AUTOMATIC or any of the other five override buttons.

VENT button

Push this button to select outside air through the instrument panel registers. The display window will show the set temperature and VENT to the lower right of the temperature. Your EATC will heat the air if the temperature you have selected is warmer than the outside air coming into the vehicle. However, the air will NOT be cooled regardless of the temperature setting.

PNL & FLR button

Push this button to get air from the floor and instrument panel registers at the same time. The display will show the set temperature and the words PNL and FLR. Depending on the selected temperature, the air will be automatically heated or cooled.

FLOOR button

Airflow will be to the floor when the FLOOR button is pressed. The display window will show the set temperature and FLR to the left of the temperature. The air cannot be cooled in the FLOOR position, only heated. Fan speed will be automatic unless manually controlled. If you override the fan speed and wish to return to automatic fan control, push AUTOMATIC. Then, again select FLOOR for airflow to the floor.

FLR & DEF button

Push this button to get air to the floor and windshield defrosters at the same time. The display will show the set temperature, FLR and the Defrost symbol. If the outside temperature is about 50°F (10°C) and above, the air will be dehumidified to remove moisture. This will help to prevent fogging in humid weather.

DEFROST button

Press the Defrost Button to obtain maximum airflow to the windshield. Adjust the temperature setting as required for defrosting. The Display window will show the temperature setting with the Defrost symbol to the left of the temperature. When the outside temperature is about 50°F (10°C) and above, the air will be dehumidified to remove moisture. This will help prevent fogging in humid weather.

OUTSIDE TEMP button

By pressing this button the temperature of the air outside of the vehicle will show in the display. The outside temperature will continue to be displayed until the OUTSIDE TEMP button is pressed again to cancel. If the selected temperature setting is changed while the outside temperature is displayed, the new selected temperature will be displayed for 4 seconds after it is changed. Then, the outside temperature will return to the window. If a manual override is pressed or the thumbwheel is rotated while the outside temperature is displayed, the window will show the change for 4 seconds. Then, the outside temperature will return along with the changed override selection.

OUTSIDE TEMP

88 °F

If the EATC is turned OFF while the outside temperature is displayed, the temperature will continue to be displayed. Press the OUTSIDE TEMP button to clear the display window. When the ignition key is turned OFF the display will be blank (dark).

NOTE: The outside temperature reading is most accurate when the vehicle is moving. Higher readings may be obtained when the vehicle is not moving. The readings that you get may not agree with temperatures given on the radio due to differences in vehicle and station locations.

Operating tips

The following tips will help you to get the most satisfaction from your Electronic Automatic Temperature Control system.

- In humid weather, select DEF before starting your engine. This will help to prevent windshield fogging. After a few minutes of operation, switch to AUTOMATIC or an override selection of your choice.
- To prevent humidity buildup inside your vehicle, always drive with the EATC System turned on.

- ❑ Do not put objects under the front seats that interfere with the flow of air to the back seat area.
- ❑ Remove any snow, ice, or leaves from the air intake area of your EATC System which could block the air intake. The intake area is located at the bottom of the windshield, under the hood at the passenger side rear corner.

Service

If your EATC is not operating as described here, take it to your dealer to have it checked. System diagnostics are built in which will allow your dealer to readily identify problems that might occur.

Rear Window Defroster and Heated Sideview Mirrors

The rear window and heated outside mirrors defroster switch activates the defroster for the rear window to clear frost, fog, or thin ice from both the inside and outside of the rear window and activates the heated outside rearview mirrors.

The button for the rear window and heated outside mirrors defroster is on the instrument panel to the right of the steering column.

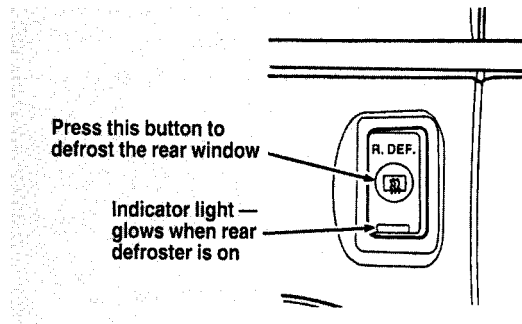

The button that controls the rear window defroster and heated outside rearview mirrors

Clear away any snow that is on the rear window and outside rearview mirrors before using the defroster. With the engine running, push the defroster button.

After approximately 10 minutes, the defroster will turn off. If the window or mirrors are still not clear, turn the defroster on again.

The defroster will turn off when the ignition key is turned to the OFF or START position.

The heating elements are bonded to the inside of the rear window. Do not use sharp objects to scrape the inside of the rear window or use abrasive cleaners to clean it. Doing so could damage the heating elements.

The Interior and Exterior Lights

Daytime Running Light System

(Canadian vehicles only)

The Daytime Running Light (DRL) system turns the high beam headlamps on, with a reduced light output, when:

The headlamp system is in the OFF position, and

The vehicle is running, and

The vehicle has a fully released parking brake.

The high beam indicator light on the instrument cluster will not be on.

NOTE: If you have a vehicle with an automatic lighting system, the DRL system is active until the automatic system turns on the headlamps.

NOTE: You may notice that the lights flicker when the vehicle is turned on or off. This is a normal condition.

!WARNING

The Daytime Running Light (DRL) system will not illuminate the tail lamps and parking lamps. Turn on your headlamps at dusk. Failure to do so may result in a collision.

Turning On the Exterior Lights

To turn on the headlamps, parking lamps, side markers, and tail lamps, use the rotary switch that is to the left of the steering wheel.

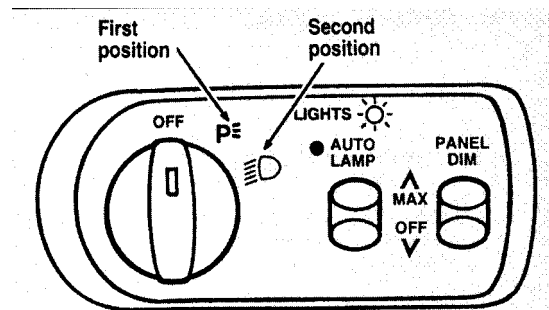

The knob for the exterior lights

To turn on the parking lamps, tail lamps, and license plate lamps, turn the knob clockwise to the first position.

For more information about how the high beams work, refer to the *Steering Column Controls* chapter.

Cleaning the Exterior Lamps

Do not use dry paper towel, chemical solvents or abrasive cleaners to clean the lamps, as these may cause scratches or crack the lamps.

Setting the Autolamp On/Off Delay System

By using the autolamp, you can set the headlamps to:

- turn on the lamps automatically at night
- turn off the lamps automatically during daylight
- keep the lamps on for up to three minutes after you turn the key to OFF.

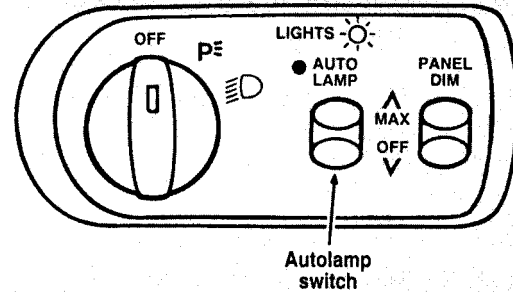

The autolamp switch is on the left side of the instrument panel.

To use the autolamp:

1. Make sure the headlamp knob is in the OFF position. If the knob for the headlamps is ON, you cancel the autolamp.

If the autolamp is active, the headlamp system will come on immediately after starting your vehicle. If your vehicle is running before you activate the autolamp, there may be a 15 second delay before the headlights illuminate.

2. Turn the ignition key to ON or start your vehicle.
3. Find the autolamp switch to the left of the steering wheel on the instrument panel.
4. Push the autolamp switch up toward the MAX position. As you press this switch, the autolamp system's status will be displayed in the message center. The system can be turned OFF or can be set to provide light for up to three (3) minutes after you turn your vehicle off.

Do not put any articles on top of the photocell that is located in the top left corner of the instrument panel. This photocell controls the autolamp. If you cover it, the photocell reacts as if it is nighttime, and the lamps turn on.

To turn the autolamp off, push the switch down until the message center display reaches OFF.

Turning On Interior Lights/Instrument Panel Illumination

You can brighten or dim the lights in the instrument panel and the compass display in the inside rearview mirror (if equipped) with the PANEL DIM switch located on the instrument panel.

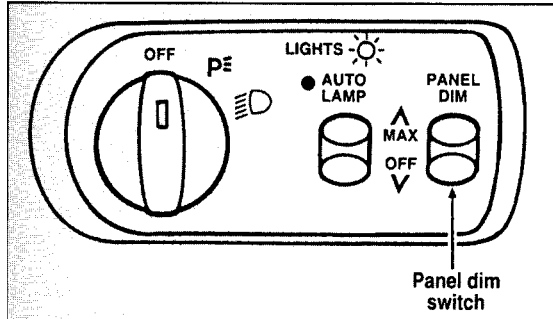

The switch that controls interior lamps and instrument panel brightness

To turn on the interior lights, hold the Panel Dim switch up until the interior lights turn on. To turn off the interior lights, push the Panel Dim switch down. The interior lights also come on when any door is opened or if either front door outside handle is lifted with the door locked.

Turning On the Map Lamps

Your vehicle has a map lamp for the passenger and one for the driver.

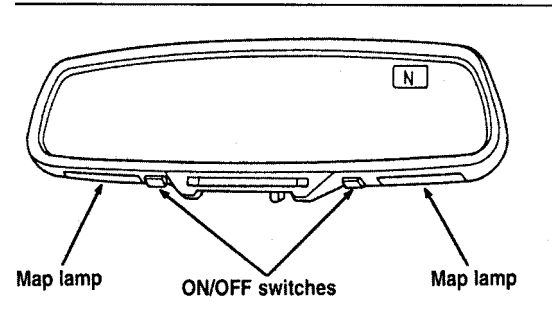

The map lamps on vehicles equipped with a moon roof

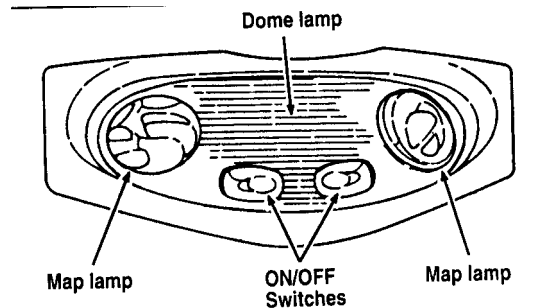

The map lamps on the inside roof of the car

To turn on the map lamps, push the switches in front of each lamp.

On vehicles equipped with the moon roof Option, the map lamps and switches are located on the inside rearview mirror.

Rear Courtesy/Reading Lamps

Your vehicle has two rear passenger courtesy/reading lamps.

The courtesy lamp lights when any door is opened or when the instrument panel dimmer switch is turned to the courtesy lamp position or if either front door outside handle is lifted with the door locked.

With the ignition key in the ACC or ON position, the reading lamp can be turned on by using the rocker switch on the lamp assembly.

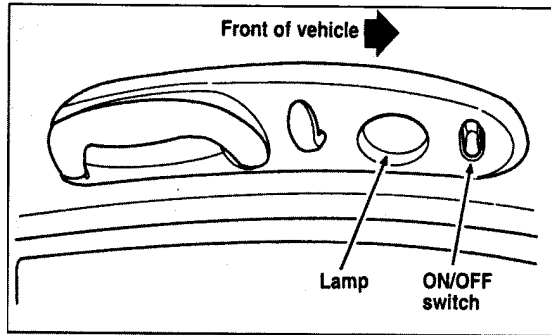

Rear passenger courtesy/reading lamp

Cleaning the Interior Lamps

Your interior dome lamps and map lamps are plastic and should be cleaned with a mild detergent diluted in water. Rinse them with clear water.

Clock

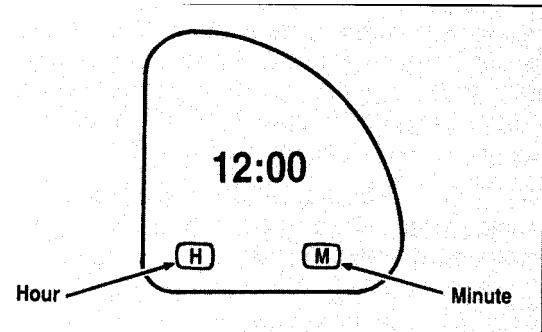

The digital clock

1. To set the hour, press and hold the hour button. When the desired hour appears, release the button.
2. To set the minutes, press and hold the minute button. When the desired minute appears, release the button.

Cellular Phone (If equipped)

For information about the cellular phone in your vehicle, refer to the *Cellular Phone User's Manual* provided with your phone. For further questions about your Lincoln cellular phone, contact the Ford Cellular System at 1-800-367-3013(U.S.). In Canada, please contact your dealer.

NOTE: It is recommended that you fold your cellular phone antenna down onto the back glass before entering a car wash.

Steering Column Controls

The controls on the steering column and wheel are designed to give you easy access to the controls while you are driving.

The Turn Signal Lever

You can use the turn signal lever on the left side of the steering column to:

- operate the turn signals and cornering lamps
- turn the high beams on/off
- flash the lights
- turn the windshield wipers and washer on/off

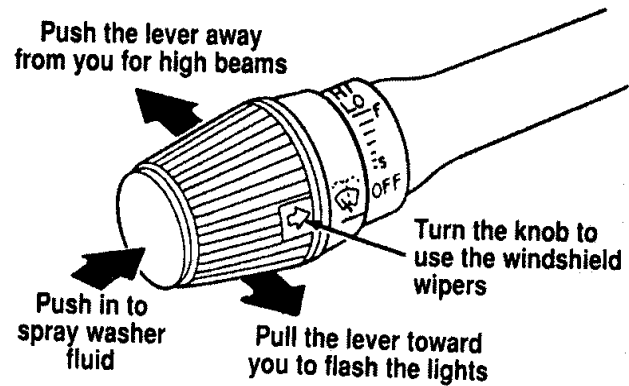

The turn signal lever

Turn Signals

Move the lever up to signal a right turn. Move it down to signal a left turn. The corresponding indicator light in the instrument cluster will flash.

If the turn signal stays on after you turn, move the lever back to the center (off) position. A warning chime will sound after approximately one-half mile (one kilometer) of driving if you do not return the lever to off.

For lane changes, move the lever far enough to signal but not to latch. The lever will return to the off position when you release it.

NOTE: The flash rate of the turn signal will speed up considerably if the Lighting Control Module detects a left or right turn lamp bulb (front or rear) is burned out.

High Beams

To turn on the high beams, turn the headlamp control switch to the headlamp ON position (or activate the autolamp feature) and push the turn signal lever away from you until it latches. When the high beams are ON, the high beam indicator light on the instrument cluster comes on.

To turn off the high beams, pull the lever toward you until it latches. The high beam indicator light turns off.

Flashing the Lights

To flash the headlamps, pull the lever toward you for a moment and then release it. The headlamps will flash whether the headlamp knob is in the on or off position.

Windshield Wipers and Washer

To turn on the windshield wipers, the ignition key must be turned to the ON or ACC position.

Rotate the knob towards "S" to activate the wipers. The first seven detents are interval wipe positions, the eighth detent is the LO position and the ninth detent is the HI position.

To turn the wipers off, turn the knob to the OFF position.

Variable Interval Wipers

In addition to two speed wipers, your vehicle has wipers that you can set to operate at varying intervals. For example, you can set the interval so they wipe less often when it drizzles or more often in heavier rain.

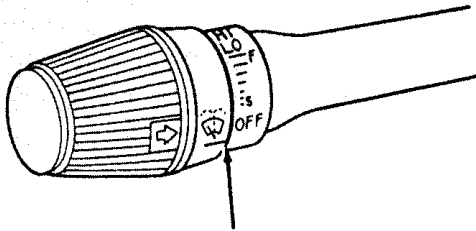

The closer the knob is to off, the less often the wipers move

The windshield wiper on the turn signal lever

To set the interval wipers, turn the -knob at the end of the turn signal lever between "S" (slow) and "F" (fast) until the desired interval between wipes is achieved.

Windshield Washer

To clean the windshield, push in the end of the wiper knob. For a constant spray, keep the knob pushed in. After you release the knob, the wipers operate for two to three cycles before turning off (if the wipers were OFF) or returning to HI, LO, or the interval setting selected.

If the washer does not work, check the washer fluid level and fill it if it is low. See the *Servicing Your Continental* chapter. If there is enough fluid, consult your nearest Ford or Lincoln-Mercury dealer.

Do not try to clean the windshield when the washer fluid container is empty or activate the washers at any time for more than 15 seconds continuously. This could damage the washer pump system.

! WARNING

In freezing weather, the washer solution may freeze on the windshield and obscure your vision. Always warm up the windshield with the defroster before you use the washer fluid. If you cannot see through the windshield clearly, it can increase the risk of being involved in a collision.

For information about refilling the washer fluid or replacing your windshield wiper blades, see *Windshield washer fluid and Wipers* in the Index.

Hazard Flasher

The hazard flasher serves as a warning to other drivers to be careful when approaching or passing your vehicle.

The flashers work whether your vehicle is running or not. The flashers work for up to two hours when the battery is fully charged and in good condition without draining the battery excessively. If the flashers run for longer than two hours or if the battery is not fully charged, the battery can be drained.

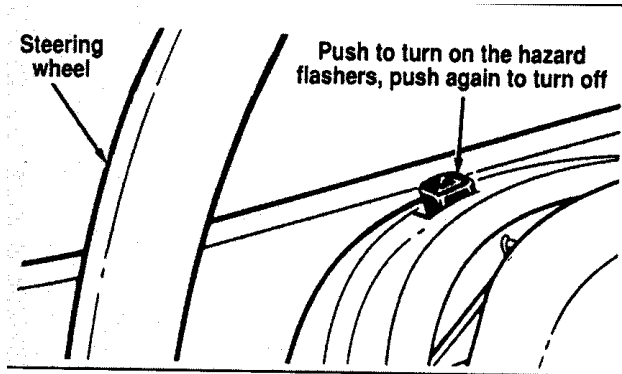

The control switch for hazard flashers

Horn

To sound the horn, push the center pad area of the steering wheel.

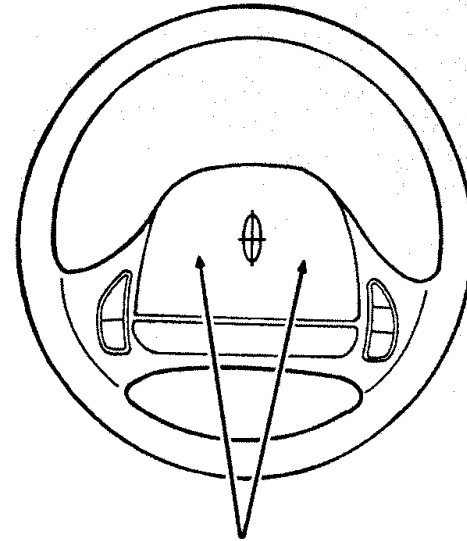

Press here to sound the horn

The horn on the steering wheel

Tilt Steering

⚠ WARNING

Never adjust the steering wheel when the vehicle is moving.

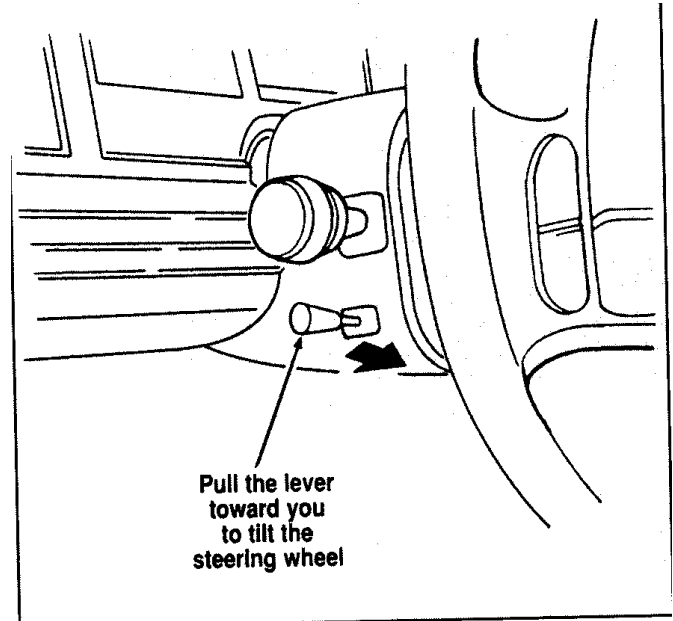

The lever to tilt the steering wheel

To change the position of the steering wheel, pull the release lever on the column toward you. Tip the steering wheel to the desired position. Release the lever to lock the steering wheel in place.

Speed Control

Your vehicle has speed control, so you can automatically maintain a constant speed above 30 mph (48 km/h). The switches to operate the speed control are on the steering wheel.

Use of radio transmitting equipment that is not Federal Communications Commission (FCC) or in Canada the Canadian Radio and Telecommunications Commission (CRTC) approved may cause the speed control to malfunction. Therefore, use only properly installed FCC (CRTC in Canada) approved radio transmitting equipment in your vehicle.

NOTE: Since your vehicle has an Automatic Overdrive Transaxle, you may want to drive in D (Drive) when driving in hilly terrain, at higher altitudes, or when pulling a trailer. This will improve speed control performance.

NOTE: Do not shift to N (Neutral) when using the speed control. This will cause the engine to overspeed.

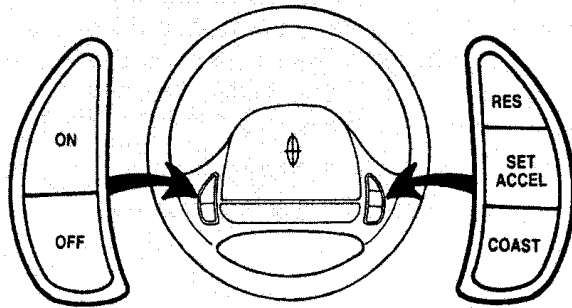

The speed control switches on the steering wheel

To set the speed control:

1. Press and release the ON switch.
2. Accelerate to the desired speed above 30 mph (50 km/h) using the accelerator pedal.

3. Press the SET ACCEL switch and release it immediately to set your speed. If you keep this switch pressed, your speed will continue to increase.
4. Take your foot off the accelerator pedal. Your vehicle will maintain the speed you set.

If you drive up or down a steep hill, your vehicle may momentarily slow down or speed up, even though the speed control is on. This is normal.

When driving uphill, especially with a heavy load, significant speed drops may occur. If the speed drops more than 8-14 mph (13-23 km/h) the automatic speed control will, by design, be cancelled. If this happens, your vehicle may require manual operation to maintain your desired speed.

NOTE: If your speed increases above your set speed while driving in **D** (Overdrive) on a downhill grade, you may want to shift to **D** (Drive) to reduce vehicle speed. The speed control cannot reduce the vehicle speed if it goes above your set speed on a downhill grade. For the best fuel economy during normal driving conditions, leave the shift select in **D** (Overdrive), or resume as soon as practical.

! WARNING

Do not use the speed control in heavy traffic or on roads that are winding, slippery, or unpaved.

Accelerating With the Speed Control Operating

You can use the accelerator pedal to speed up momentarily. When you take your foot off the accelerator, the vehicle will return to the set speed.

Resetting the Speed Control

To reset the speed control to a **lower speed**, use one of the following procedures:

- COAST** - Press and hold the COAST switch. Release the switch when the vehicle slows down to the desired speed.
- Lightly tap the brake pedal. When the vehicle attains the desired speed, press the SET ACCEL switch and release it immediately.
- TAP-DOWN** - Press and release the COAST switch momentarily for each m.p.h. (1.6 km/h) reduction in speed desired.

If vehicle speed is reduced below 30 mph (50 km/h) by any of the above methods, then you must manually accelerate to a speed over 30 mph (50 km/h) and reset the system.

To reset the speed control to a **higher speed**, follow one of these procedures:

- ACCEL** - Press and hold the SET ACCEL switch. Release the switch when the vehicle has accelerated to the desired speed.
- Depress the accelerator pedal. When the vehicle attains the desired speed, press the SET ACCEL switch and release it immediately.
- TAP-UP** - Press and release the SET ACCEL switch momentarily for each m.p.h. (1.6 km/h) increase in speed desired.

To Cancel Speed Control

Speed control can be cancelled at any time by pressing the brake pedal slightly. After cancelling, you can return to the speed you set by pressing the RES switch, or set a new speed by pressing the SET ACCEL or COAST switches.

To Turn Speed Control Off

Press the OFF switch.

Speed control is also turned OFF each time the vehicle ignition is shut off.

Cancelling and Resuming a Set Speed

If you press the brake pedal, speed control is suspended. You can return to the set speed by pressing the RES switch, as long as you did not press the OFF switch. You must be driving at least 30 mph (48 km/h).

Your vehicle will gradually return to the previously set speed and then maintain it.

Features

Your vehicle has a variety of features designed for your comfort, convenience and safety. Read this chapter to find out about standard and optional features.

Doors

Childproof Locks for the Rear Doors

In addition to power locks, your vehicle has childproof locks for the rear doors. If you set these locks, the rear doors cannot be opened from the inside of the vehicle. The doors can still be opened from the outside when the lock knobs are raised.

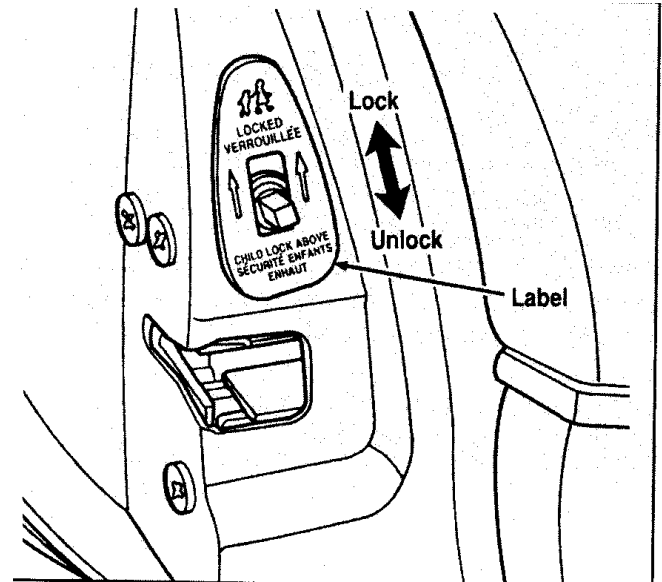

The childproof locks for the rear doors

To set the childproof lock on each rear door, open the rear door.

Find the lever at the black label with the word LOCKED in white letters. Move the lever up.

To release the childproof lock, open the rear door from the outside.

Move the lever down.

Using the Power Door Locks

Your vehicle has power door locks. The controls to lock the doors are on the trim panel of the front door. When you close the doors after you set the door locks, the doors remain locked. If the power mechanism ever fails, the manual door lock will override the power controls.

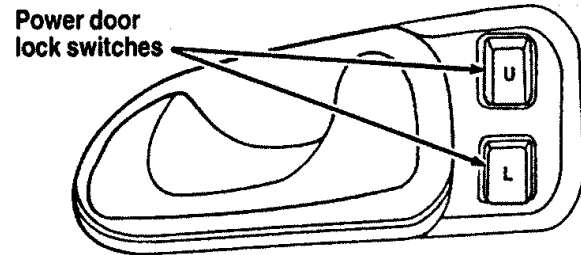

The power locks on the driver's door

Smart Locks

The Smart Locks feature helps prevent you from locking the keys in your vehicle. With the key in the ignition (in any switch position) and either the driver's or passenger's door open, the doors cannot be locked using the front door lock switches.

NOTE: Your vehicle can still be locked, while the key is in the ignition, by manually pressing down the lock button or with remote/keyless entry.

Illuminated Entry System with Theater Lighting

The interior lights will illuminate for approximately 25 seconds when either front door handle is lifted, any button on the keyless entry pad is pressed, or the remote entry system UNLOCK button is pushed. If the amount of light outside your vehicle is below a predetermined level, the exterior lights will also illuminate.

Using the Keyless Entry System

You can lock or unlock the vehicle doors and open the trunk without using a key. The buttons for the system are below the outside door handle on the driver's side. See also *Remote Entry System* which follows this description.

Press the middle of the button. There is only one switch under each button.

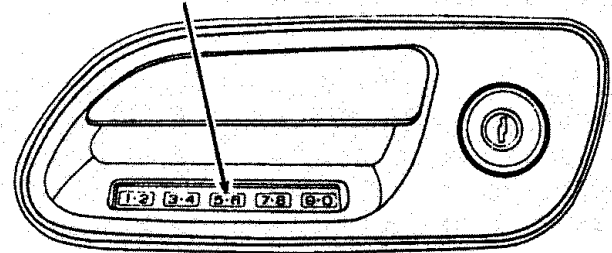

**Each Button Has
Two Numbers**

The keyless entry buttons

When you bought your vehicle, you were given a computer code that operates the system for your vehicle. For your convenience, we have duplicated this code in three places.

The code is:

- on your owner's wallet card found in the glove compartment

- taped to the trunk lid's right hinge support bar
- taped to the computer module in your driver's front door

When you use keyless entry, the illuminated entry system turns on the interior lights for 25 seconds and the buttons on the keypad light up. Do not push the buttons with a key, ballpoint pen, pencil, or any other hard object. These objects could damage the buttons.

Unlocking the doors with the keyless entry system

You must unlock the driver's door before you unlock any of the other doors or trunk. If you let more than five (5) seconds pass before pressing numbers, the system shuts down, and you have to enter the code again. The system has shut down if the keypad light is out. If the keyless entry system does not work properly, use the key or transmitters to lock and unlock the doors or unlock the trunk.

- 1 To unlock the driver's door, enter the factory code or your personal code. All codes have five (5) numbers. After you press the fifth number, the driver's door unlocks.
- 2 To unlock all passenger doors, press the 3/4 button within five (5) seconds of unlocking the driver's door or trunk, or re-enter the code to open the driver's door, then press 3/4.
- 3 To unlock the trunk, press the 5/6 button within five seconds of unlocking the driver's or passenger's doors, or re-enter the code to open the driver's door, then press 5/6.

As long as the driver's door has been unlocked first, you can open the passenger door or the trunk in any order.

Locking the doors with the keyless entry system

Along with unlocking your doors, you can use the keyless entry system to lock the doors.

To lock all of the vehicle's doors at the same time, press 7/8 and 9/0 at the same time. It is not necessary to first enter the keypad code. This will also arm your anti-theft system (if equipped).

Autolock

The Autolock feature will automatically lock all the doors when:

- the vehicle's doors are fully closed
- the ignition key is turned to the ON position
- someone is sitting in the driver's seat or a heavy object is placed on it
- the vehicle is in a forward gear, and D you exceed three mph (five km/h). The Autolock feature will repeat when: LI the ignition key remains in the ON position
- someone remains sitting in the driver's seat or a heavy object is on the seat

- a door is opened and then closed
- the vehicle is in a forward gear, and
- you exceed three mph (five km/h).

If you do not want to use the Autolock feature, it can be deactivated by using the Feature Menu in the Message Center.

Programming your own entry code

You can program up to three personal codes to unlock your vehicle. These codes do not replace the permanent code that the dealership gave you. Use your personal code in the same manner as you would your original code.

To program your own code:

1. Select five digits for your personal code.
2. Enter the factory code that the dealership gave you.
3. Within five (5) seconds, press 1/2.

4. Within five (5) seconds of pressing 1/2, enter your personal code, pressing each digit within five (5) seconds of the previous digit.
5. Enter a sixth digit to indicate which Personality should be recalled by this personal code.

1/2 Recall Personality 1

3/4 Recall Personality 2

9/0 No recall

An of the vehicle doors will lock and then unlock to confirm programming of the new code.

The keyless entry system registers this new code. To open your vehicle, you can now use either code.

To erase all of the personal entry codes and remote entry transmitters programmed to a vehicle:

1. Enter the original permanent code.

2. Press 1/2 within five (5) seconds of Step I.
3. Press and hold 1/2 for two (2) seconds.

All of the vehicle doors will lock and then unlock to confirm erasure.

Do not set a code that presents the numbers in sequential order, such as 1/2, 3/4, 5/6, 7/8, 9/0. Studies show that people who idly press the buttons usually press a sequential pattern. Also, do not select a code that uses the same button five times. Thieves can easily figure out these types of codes.

Arming, disarming and resettirig your anti-theft system (If equipped) from the keyless entry pad

If your vehicle is equipped with the optional factory installed anti-theft system, the keyless entry system will arm it when you use the 7/8 and 9/0 keys to lock the doors, and will disarm or reset a triggered anti-theft alarm when you enter in the five digit code to unlock the driver's door.

Remote Entry System

With the remote entry system, you can lock and unlock the vehicle doors and open the trunk without using a key. The buttons for the system are located on the two hand held transmitters that came with your vehicle. The remote also has a personal alarm feature.

The system will work with up to four transmitters. Your vehicle came with two transmitters. Additional transmitters can be ordered from your dealer.

The personal alarm feature operates only with the ignition off. The LOCK, UNLOCK and TRUNK features work whenever your vehicle is in Park or Neutral.

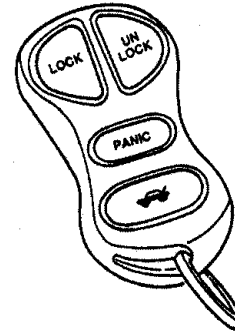

Remote entry transmitter

Unlocking the doors and opening the trunk

To unlock the driver's door, press the UNLOCK button.

To unlock the other doors, press the UNLOCK button a second time within five (5) seconds of unlocking the driver's door.

To open the trunk, press the TRUNK button twice within five (5) seconds.

Locking the doors

To lock all the doors, press the LOCK button. This will also arm the anti-theft system (if equipped).

A programmable door lock horn chirp can be activated through the message center. Once activated, every depression of the lock button will cause the vehicle to honk its horn briefly.

Activating the remote personal alarm

If you wish to activate the remote personal alarm, press the PANIC button. This will honk the horn and flash the low beam headlamps and tail lamps for approximately two minutes and forty-five seconds. You can turn it OFF by pressing the PANIC button again or by turning the ignition key to the RUN position.

Arming and disarming the alarm s system

If your vehicle is equipped with the factory installed anti-theft system, the remote entry system will automatically arm it when the doors are locked with the remote entry LOCK button. The remote entry UNLOCK button will disarm or reset a triggered anti-theft alarm.

The remote entry system is designed to work with the factory installed anti-theft system. It may not work with other anti-theft systems.

Replacing the batteries

The remote entry transmitter is powered by two coin type three-volt lithium 1616 batteries (included) that should last for several years of normal use. If you notice a significant decrease in operating range, the batteries should be replaced. Replacement batteries can be purchased at most pharmacies, watch stores or at your Ford or Lincoln-Mercury dealer.

NOTE: The operating range of the remote entry system can also be affected by weather conditions (such as very cold temperatures) or structures around the vehicle (buildings, other vehicles, radio and TV towers, etc.). Typical operating range will allow you to be up to 33 feet (10 meters) away from your vehicle.

The transmitter can be snapped apart to replace the batteries by twisting a thin coin between the two halves of the transmitter. **DO NOT TAKE THE FRONT PART OF THE TRANSMITTER APART.** When installing the new batteries, be sure to place the positive (+) side down as marked. Snap the two halves back together.

Replacement / additional transmitters

In the event a transmitter is lost, a new one may be purchased from your dealer.

To program replacement or additional transmitters you must have all the transmitters intended for use on your vehicle.

Initiating the following procedure erases all prior programmed transmitters, thus ALL must be reprogrammed at the same time.

1. Enter the factory keyless entry code. Your personal code will not allow programming.
2. Press the 1/2 button.
3. Press one button on each of the transmitters to be programmed. Each transmitter button must be pressed within seven (7) seconds of the prior one. Each time a transmitter is successfully programmed, all of the vehicle doors will lock and then unlock to verify programming. If the doors did not lock/unlock, your transmitter was not programmed.

Additional transmitters may be purchased from your dealer (remote entry system will work with up to four transmitters). Follow the same programming procedure as above.

THIS DEVICE COMPLIES WITH PART 15 OF THE FCC RULES. OPERATION IS SUBJECT TO THE FOLLOWING TWO CONDITIONS: (1) THIS DEVICE MAY NOT CAUSE HARMFUL INTERFERENCE, AND (2) THIS DEVICE MUST ACCEPT ANY INTERFERENCE RECEIVED, INCLUDING INTERFERENCE THAT MAY CAUSE UNDESIRE OPERATION.

NOTE: All transmitters to be used on your vehicle must be programmed/reprogrammed at the same time.

Battery Saver

When the ignition is turned off, the vehicle will turn off battery voltage to the interior lights after 45 minutes.

This will prevent draining of the battery if those lights have been left on inadvertently or if a door is not completely closed. BatterV voltage to these

lamps will be restored when the outside front door handles are lifted, the keyless entry keypad is used, the remote entry transmitter is used, any door is opened, the trunk is opened, or the ignition key is turned to the ON position.

Anti-theft System

When armed, this system helps protect your vehicle against break-ins or theft by monitoring all doors, the hood, and the trunk lock cylinder.

When an unauthorized entry occurs, the system triggers and will:

- flash the headlamps, parking lamps, interior lamps, and alarm indicator light
- honk the horn
- prevent the engine from starting

NOTE: The factory installed Remote Entry System has a PANIC feature that also chirps the vehicle horn and flashes the interior/exterior lamps when the PANIC button on the remote entry transmitter is pushed. **The PANIC alarm and the Anti-Theft alarm are two separate features.** Both the anti-theft alarm and the PANIC feature can be active at the same time.

To tell the difference between a PANIC alarm and a triggered Anti-Theft alarm:

- only the Anti-Theft alarm will cause the alarm indicator light (located in the center of the instrument cluster) to flash on and off.
- only the Anti-Theft alarm will prevent the engine from starting.

For more information on the PANIC alarm, see *Remote Entry System* in the Index.

Arming the system

To arm the system, do the following four steps in sequence.

1. Remove the key from the ignition.
2. Open any door. The alarm indicator light will start flashing to remind you to arm the system.
3. Lock the doors by using the power door lock switch, pressing the remote entry transmitter LOCK button or pressing the last two buttons (7/8, 9/0) of the keyless entry keypad.

The alarm indicator will now glow steadily.

4. Close all doors. The alarm indicator light will then remain on steadily for approximately 30 more seconds and then go out. When the light goes out the system is armed.

NOTE: Be sure to close all doors completely. If not, the alarm indicator light will remain on. Remember, your anti-theft system is armed only after the alarm indicator light remains on steadily for approximately 30 seconds after the last door is closed, and then goes out.

You can also arm the anti-theft system with the factory installed remote entry system or the keyless entry system by following this sequence:

1. Remove key from ignition.
2. Close all of the doors.
3. Press the remote entry transmitter LOCK button or press the last two buttons (7/8, 9/0) of the keyless entry keypad to lock the doors. The alarm indicator will come on for 30 seconds to show the alarm is arming and then turn off to show that the alarm has armed.

The anti-theft system is designed to work with the factory installed remote entry system. It may not work with other remote entry systems.

NOTE: The anti-theft system will not activate while someone is sitting in the driver's seat or if there is a heavy object in the driver's seat.

Disarming an untriggered anti-theft system

You can disarm the system by:

- unlocking a front door with the key (turn the key all the way to the end of travel or the system will not disarm).
- using the keyless entry unlock code.
- using the UNLOCK button of the remote entry transmitter.

If you armed the system while inside your vehicle, you can disarm it by turning the ignition to the ON or ACC position. This allows you to open the door and exit without triggering the system.

Triggering the alarm system

The armed system will be triggered if:

- any door is opened without disarming the system (see previous paragraphs), or
- the trunk lock cylinder is removed, or

NOTE: You can open the trunk with your key without setting off the alarm.

- the hood is opened.

Disarming a triggered system

The alarm can be disarmed by:

- unlocking a front door with the key
- using the keyless entry unlock code
- using the UNLOCK button of the remote entry transmitter

NOTE: The flashing lights and honking horn will shut off automatically approximately three minutes after the system is triggered. It will trigger again if another intrusion occurs. However, the engine will not be allowed to start until the system is disarmed.

Windows

Using the Power Windows

Each door has a power control that opens and closes the window on that door. The driver's door has a master control panel that operates all four windows.

Power windows can only be opened or closed when the ignition **is** in the ON or ACC position or during the ten minute delayed accessory period after the ignition is turned off.

⚠️WARNING

Do not let children play with the power windows. They may seriously hurt themselves. Make sure occupants are clear of the window(s) before closing.

NOTE: Your vehicle is also equipped with a delayed accessory timer. This allows some of your accessories to remain on for up to 10 minutes after the key is turned to the OFF position. The accessory timer is cancelled if any door is opened or the key is turned to the ON position.

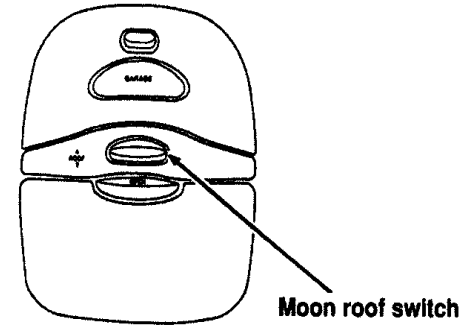

The master controls on the driver's door

To lock out all window switches except the master controls, press the window lock switch once. To restore control to the individual windows, press the switch again.

There is also an Express Down feature on the driver's power window. This feature can be activated through the menu functions of your Message Center.

To operate, briefly press the driver's window switch to the down position. The window will then open automatically. To stop automatic operation, briefly press the switch again to either the up or down position. More than a quick press of the switch provides conventional power window operation. Closing of the power window is conventional operation only.

Moon Roof (If equipped)

You can move the moon roof back to open the glass panel, or you can tilt it up to ventilate the vehicle.

The roof console ROOF switch is used to open and close the moon roof. Press and hold the switch until the desired position is reached. At the fully closed position, the motor automatically turns off.

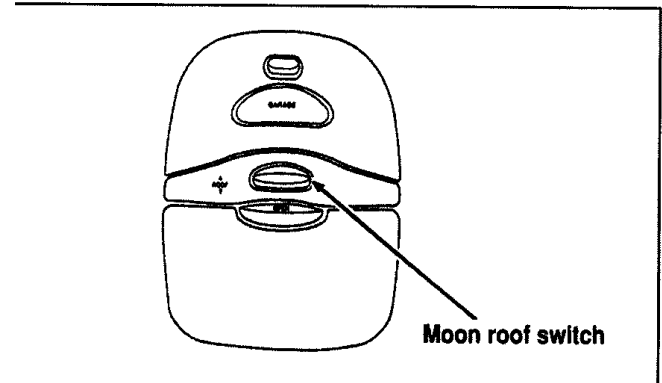

The switch for the moon roof (overhead console)

To open the moon roof, push switch rearward.

To close the moon roof, push switch forward.

To tilt the moon roof into vent position when the glass panel is closed, press and hold the switch forward.

To close from vent position, press and hold the switch rearward.

Occasionally wiping the outside guide rail covers of the moon roof with a clean cloth will help keep the moon roof working properly.

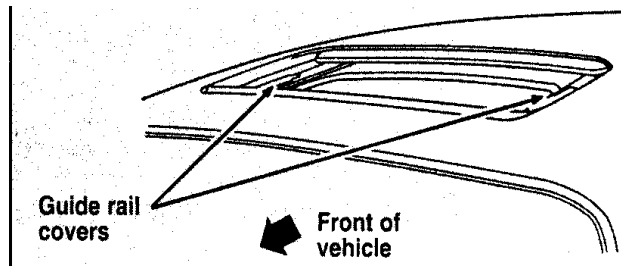

The moon roof

⚠️WARNING

**Do not let children play with the moon roof.
They may seriously hurt themselves.**

Seats

Head Restraints

If you use them properly, head restraints will help protect your head and neck in a collision.

A head restraint should be placed as high as possible behind your head without interfering with your vision.

You can adjust the head restraints for your comfort and protection.

Four-way head restraints

Your vehicle has the four-way head restraint. You can adjust it in four directions. You can raise it two (2) inches (50 mm) from its normal position, or you can move it forward up to 60° until you reach the desired position.

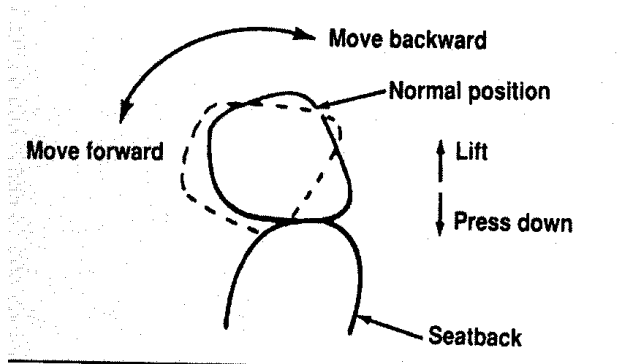

The four-way head restraint

Adjusting the Seats

⚠ WARNING
Never adjust the driver's seat or seatback when the vehicle is moving.

⚠ WARNING
To reduce the risk of serious injury in a collision, always drive and ride with your seatback upright and the lap belt snug and low across the hips.

⚠ WARNING
Do not pile cargo higher than the seatbacks to avoid injuring people in a collision or sudden stop.

Using the Power Seats

Your vehicle's power seats can be adjusted in several directions. You can raise or lower the whole seat, move the seat forward or backward and tilt the front and back of the seat up or down.

The controls to operate the power reclining front seats are located on the inside of each front door. The arrows on the panel show the direction of the seat movement. To move the seat back, move the switch in the desired direction.

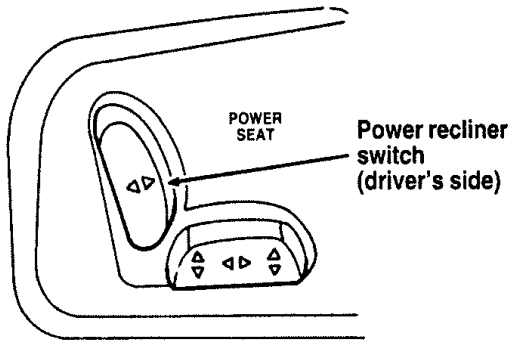

The power reclining seat switch on the driver's side

Power Lumbar Support

With this feature, you can position a lumbar support pad in the seatback.

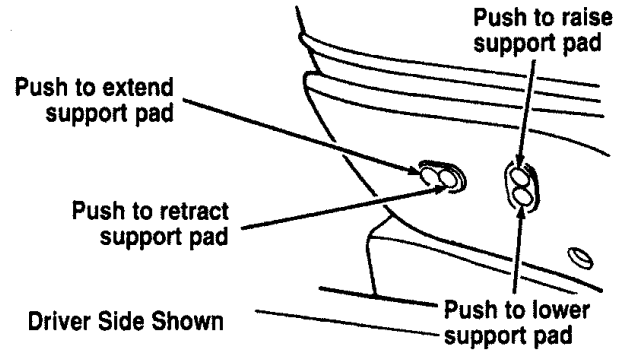

The seat controls for the lumbar support on the driver's seat

Heated Seats (If equipped)

The driver's and front passenger's Heated Seats are controlled by the HEATED SEATS panel, which is located directly below the Automatic Temperature Control panel. The Heated Seat System will only operate with the ignition key in the ON position and will maintain a temperature automatically once it is selected. NOTE: Leaving the Heated Seat turned on when you shut the vehicle off will not continue to heat the seat.

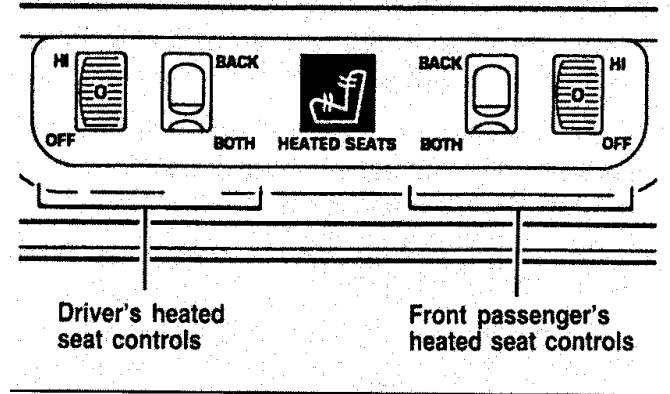

The heated seat controls

To operate the Heated Seat System:

1. Select mode
 - "Both" to heat the seat back and seat cushion
 - "Back" to heat the seat back

2. Rotate the thumbwheel from "0" to " 1 " (the lowest heat level). Allow five minutes for the heat level to stabilize.
3. If the heat level is not high enough for comfort, select increased heat levels "2' through "5" (the maximum level). Allow at least two minutes for the heat level to stabilize at any new level selected.
4. If the heated seat switch is not turned off ("0" on the thumbwheel), the seat will heat up to the selected temperature level each time the car is started.

NOTE: Cooling the seat down takes considerably longer than increasing its heat level.

Cleaning the Seats

Leather

For routine cleaning, wipe the surface with a soft, damp cloth. For more thorough cleaning, wipe the surface with a leather and vinyl cleaner or a mild soap.

Wipe the surface with a damp, soft cloth, then dry and buff with a dry, soft cloth.

Fabric

Remove dust and loose dirt with a whisk broom or a vacuum cleaner. Remove fresh spots immediately. Follow the directions that come with the cleaner.

NOTE: Before using any cleaner, test it on a small, hidden area of fabric. If the fabric's color or texture is adversely affected by a particular cleaner, do not use it.

Memory Profile System

The Personality Memory Feature customizes your Continental for up to two (2) drivers. The following features are automatically recalled when unlocking the doors using the remote entry transmitter, keyless entry keypad, or by pressing the Memory 1 or Memory 2 switches on the driver's door:

- All driver's seat positions except power lumbar and head restraint.
- Both left and right outside mirror settings.
- Radio station presets including the last selected station and band and 0 preset preferences on FMI, FM2, and AM.
- Instrument panel dimming setting.
- Autolamp delay time-out setting.
- Ride/Steering menu setting.
- Feature Menu settings

The Ride/Steering menu is located in the Message Center. The RIDE display allows you to adjust the suspension feel to FIRM, NORMAL, or PLUSH.

Pressing the Ride/Steering menu switch again brings the STEERING display. This allows you to adjust steering effort to LOW, NORMAL, or HIGH.

For more information on ride/steering options, see *Road Calibrated Suspension* later in this chapter.

Personality Memory also allows you to customize settings from the Feature menu located in the Message Center. The Feature menu contains five (5) features that you can enable or disable. The features are listed in the order they appear in the Feature menu.

- EXPRESS WINDOW - for one tap down operation of the driver's window.

- ❑ **AUTO DOOR LOCKS** - automatically locks all doors when the driver shifts out of PARK, all doors are closed, and the vehicle speed is at least three mph (five km/h).
- ❑ **HORN CHIRP** - sounds an audible "chirp" when you press the LOCK button on the remote entry transmitter to verify that the doors have been locked and the vehicle's anti-theft system has been armed (if equipped).
- ❑ **SEAT ACCESS** - moves the driver's seat back two (2) inches or to the end of the seat track when the vehicle is turned off and the ignition key is removed. Upon the driver entering the vehicle and closing the door, the seat will move forward to its previous position.
- ❑ **REVERSE MIRROR** - when the vehicle is shifted to REVERSE, the outside rearview mirrors tilt down. This provides an improved view of the side of the vehicle and curb area when backing up. When you shift out of REVERSE, the mirrors return to their previous positions.

Recalling Personality Memory

All of these settings are automatically recalled when the driver unlocks the door using the remote entry transmitter, keyless entry keypad or presses either Memory I or Memory 2 switch inside the driver's door. The vehicle must be in PARK or NEUTRAL to recall Personality Memory settings.

Remote Entry

Pressing the UNLOCK button on the remote entry transmitter unlocks the driver's door and recalls all of the Personality Memory settings. Two transmitters are delivered with the vehicle. One is programmed to always recall Memory I and the other will always recall Memory 2. Personality Memory 1 or 2 is indicated on the back of the transmitter.

Personality Memory recall from the remote transmitter can be disabled. This is done by sliding the switch on the back of the transmitter to OFF. Personality Memory can still be recalled using

keyless entry code or the Memory I or Memory 2 switches.

Keyless Entry

Up to three unique keyless entry codes can be programmed by the customer. Two of the codes can be assigned to recall Personality Memory I or Memory 2. Each time the 5-digit code is entered on the keypad, the driver's door will unlock and Personality Memory 1 or Memory 2 will be recalled.

NOTE: Please note that even though the driver's Personality Memory may be recalled using remote or keyless entry, the seats and mirrors will not move to the driver's set positions until the driver's door is opened.

Memory Switches

Pressing either the Memory I or Memory 2 switch on the driver's door will also recall the Personality Memory settings as selected, providing your vehicle is in P (Park) or N (Neutral).

Auto Save

Any change made by the driver to one of the above Personality Memory settings will be updated and saved automatically. The display, SAVED TO DRIVER I or SAVED TO DRIVER 2, will appear on the Message Center for five (5) seconds as a confirmation of the update to Personality Memory. If a radio preset is changed the radio display will also show SAVED.

If the driver does not use the remote entry transmitter, or keyless entry keypad to unlock the doors upon entering or does not press the Memory I or Memory 2 switch, then any change to one of the Personality Memory settings (except radio presets) will not be automatically saved. Instead the driver will be prompted by the Message Center whether to save the settings to Driver 1 or Driver 2.

Pressing the SELECT switch will toggle between 1, 2 or no choice. If DRIVER 1 or DRIVER 2 is selected, the display, SAVED TO DRIVER 1 or SAVED TO DRIVER 2, will appear on the Message Center to confirm the change has been automatically saved with the Personality Memory. If no choice is made by the driver, then the change will not be automatically saved and there is no effect on the Personality Memory.

Once this screen has been displayed, the driver will not be asked again for the remainder of the drive.

Turning Personality OFF

The Personality Memory feature can be turned off using the Memory OFF switch on the driver's door. The amber indicator light will be lit when the feature is turned OFF. Pressing either the Memory 1 or Memory 2 switch will turn on the Personality Memory feature and recall the saved settings.

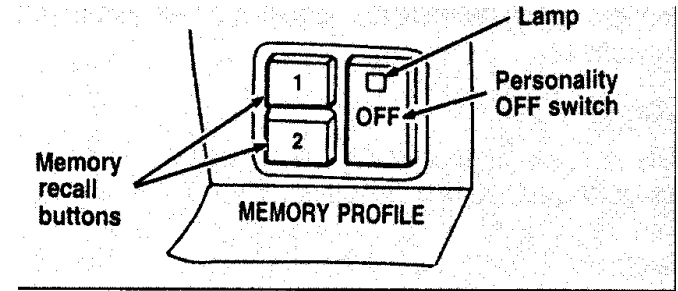

The Memory Profile System buttons

When Personality is OFF, the vehicle will function as if the Personality Memory feature was not on the vehicle. Also, when a change is made to one of the Personality settings, there will be no prompts on the Message Center asking which driver to save the setting to.

Road Calibrated Suspension

Your Continental is equipped with a ride control system that is designed to read disturbances in the road surface every six inches at 60 mph (100 km/h) to provide you with optimal driving response.

Ride control allows you to choose both a ride feel and steering effort that best fits your personal driving style. These options may be selected by using the RIDE/STEER Message Center button.

Pressing this button once will allow you to adjust your RIDE CONTROL settings, between NORMAL, PLUSH and FIRM. The settings are changed by pressing the SELECT button while RIDE CONTROL is displayed.

Pressing the RIDE/STEER button a second time will allow you to adjust the STEERING EFFORT settings between NORMAL, LOW, and HIGH. The settings are changed by pressing the SELECT button while STEERING EFFORT is displayed.

Steering

Suspension	<u>High</u>	Normal	Low
Firm	Stiff steering Stiff suspension True sports car Winding roads	Optimum steering effort Stiff suspension Sports car ride with luxury sedan steering feel	Non-optimum position Not allowed Cannot reach this state
Normal	Stiff steering Ideal ride Contemporary ride with precise steer	Ideal steering and suspension Best balance of vehicle chassis systems 'Set it and forget it" mode	Easy steering Ideal ride Traditional luxury steer and contemporary ride
Plush	Stiff steering Soft suspension Luxury ride with sport steering	Ideal steering Soft suspension Broken pavement city traffic	Easy steering Soft suspension What a Lincoln used to be (and can still be!!!)

NOTE: The combination of FIRM RIDE CONTROL and LOW STEERING EFFORT is undesirable and cannot be selected.

Mirrors

Automatic Dimming Inside Rearview Mirror (If equipped)

Some vehicles are equipped with an inside rearview mirror and an outside driver's side mirror which have an Auto-Dimming function. These electronic day/night mirrors will change from the normal state to the non-glare state when bright lights (glare) reach the mirrors. These mirrors function at night, and have a limited function at dusk or dawn. From the non-glare state, the mirrors will return to the normal state after a short delay. The delay starts when glare goes away. The delay prevents excessive changing of the mirrors as traffic moves behind and around the vehicle, or on rolling hills and curves.

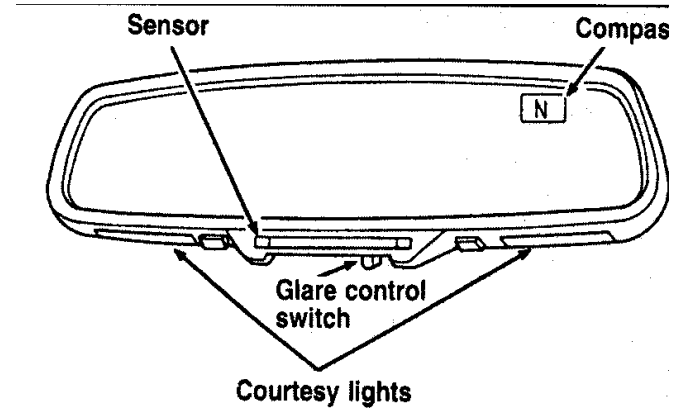

The automatic dimming inside rearview mirror (optional)

The sensitivity level of the mirrors can be adjusted by moving the switch on the inside rearview mirror between the OFF and MAX positions. MAX is the most sensitive setting and bright headlamps far away will cause the mirrors to automatically darken. At the setting nearest OFF, bright headlamps will have to be closer to darken the mirrors. The outside

side mirrors are controlled by the setting on the inside mirror.

There are two light sensors (photocells) in this mirror. The sensor that detects rear glare is located next to the switch. The second light sensor which determines outside light level is located on the backside of the mirror case.

One important safety feature is that the mirror automatically returns to the normal position whenever the vehicle is placed in R (Reverse) (when the mirror is in the ON position). This feature ensures a bright clear view in the mirror when backing up.

Do not clean the housing or glass of any mirror with harsh abrasives, fuel or other petroleum-based cleaning products.

Side View Mirrors

Your vehicle comes with electric side mirrors. The side view mirror on the right is a convex mirror. This mirror gives you a wider view of the lanes on your right and behind you.

NOTE: When putting your vehicle in reverse, both outside mirrors will tilt downward and return to the adjusted position when taken out of reverse. This feature can be disabled by using the Menu Select button on the cluster. To disable, press the menu button repeatedly until "Reverse Mirrors" appears in the display, then select OFF. To enable the reverse mirrors, select ON.

! WARNING

The side view mirror on the right makes objects appear smaller and farther away than they actually are.

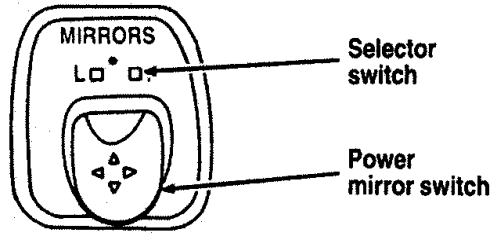

The electric remote control mirror switch

To adjust the side mirrors:

1. Find the control switch in the driver's door panel.
2. Select the right or left mirror by moving the selector switch to R or L.

3. Press any of the arrows for the direction you want to move the mirror.
4. Return the selector switch to the middle position to keep the mirror in place.

Do not clean the housing or glass of any mirror with harsh abrasives, fuel or other petroleum-based cleaning products.

Heated Mirror Feature

Both mirrors are heated whenever the Electric Rear Window Defroster is turned on. Do not remove ice from the mirrors with a scraper or you could damage them. If the outside mirror glass is frozen in place, do not attempt to readjust or move the mirror glass or damage may result.

Sun Visors

Using the Sun Visors

Your vehicle has special sun visors. Besides the regular sun visor, you have a second visor. By using both the regular sun visor and the second visor, you shield the sun from both the front and the side of the vehicle at the same time. You also have a smaller center sun visor.

To block the sun, move the main visor sideways and flip the second visor down.

Illuminated Visor Mirror

The illuminated visor mirror slides inside the visor. To light the mirror, pull down the mirror and slide switch at bottom of visor. To adjust the amount of light, slide the switch left for LO (dim) and right for HI (bright).

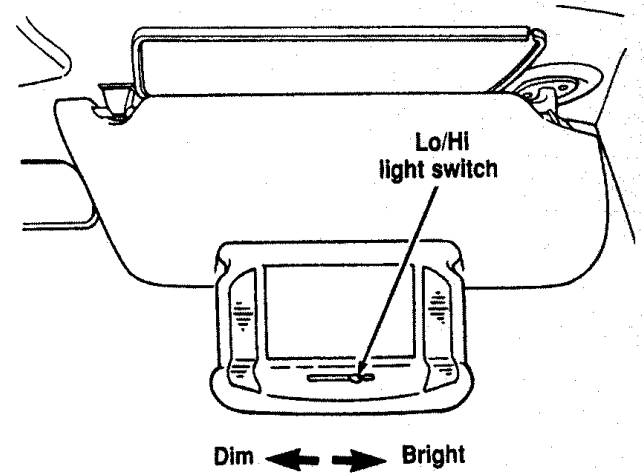

The illuminated mirror on the sun visor

Garage Door Opener

If you own a garage door opener, the overhead console of your Continental contains a bin to house your hand held garage door transmitter. This feature allows you to activate your garage door opener with a push of the GARAGE button once your transmitter has been installed inside the compartment.

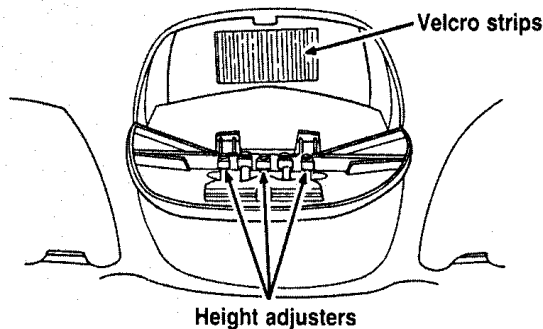

The garage door opener bin

To install your garage door transmitter, open the compartment by pressing the unmarked button near the GARAGE button. The compartment door will swing down.

Inside the compartment is a Velcro strip. Remove the backing from the strip and press the back side of your garage door transmitter to it. Be sure to situate the transmitter so that one of the five "pins" on the compartment door is in a position to make contact with the garage door transmitter's activation button after the compartment door is closed.

NOTE: There are three black "height adjusters" that can be removed and stacked on top of each other if the pin is not tall enough by itself to make contact with the garage door transmitter's activation button. These extenders may be placed on any of the five pins.

Universal Transmitter (If equipped)

The Universal Transmitter provides a convenient way to consolidate the functions of up to three individual hand-held transmitters into one built-in device.

The Universal Transmitter:

- will operate garage doors, gates, home/office lighting systems, security systems, by learning and transmitting the radio frequency of your current hand-held transmitters or nearly any device that is controlled by radio frequency.
- is built-into the driver's side visor and powered by your vehicle's battery. No separate batteries are necessary.

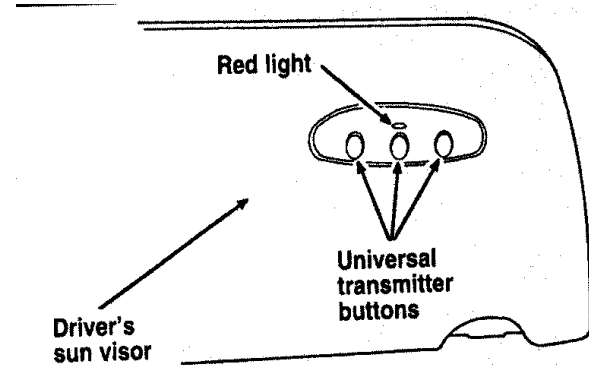

The Universal Transmitter

THIS DEVICE COMPLIES WITH PART 15 OF THE FCC RULES. OPERATION IS SUBJECT TO THE FOLLOWING TWO CONDITIONS: (1) THIS DEVICE MAY NOT CAUSE HARMFUL INTERFERENCE, AND (2) THIS DEVICE MUST ACCEPT ANY INTERFERENCE RECEIVED, INCLUDING INTERFERENCE THAT MAY CAUSE UNDESIRE OPERATION.

Programming the Universal Transmitter

NOTE: It is recommended that your hand-held transmitter contain fresh batteries prior to programming.

⚠ WARNING

Make sure that people or objects are clear of the garage door, gate, etc. while you are programming the system.

To program the Universal Transmitter:

1. Make sure your vehicle's engine is off.
2. Erase the Universal Transmitter's test codes by holding down the two outside buttons. After 20 seconds the light will begin to flash. Release both buttons immediately.

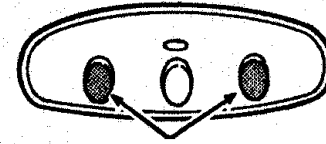

**Hold down the
outside buttons**

3. Choose one of the three Universal Transmitter buttons to program. Place the hand-held controller you want to program within one inch of the Universal Transmitter. Push and hold both the Universal Transmitter button you want to program and the hand-held controller at the same time. The Universal Transmitter light will flash slowly.

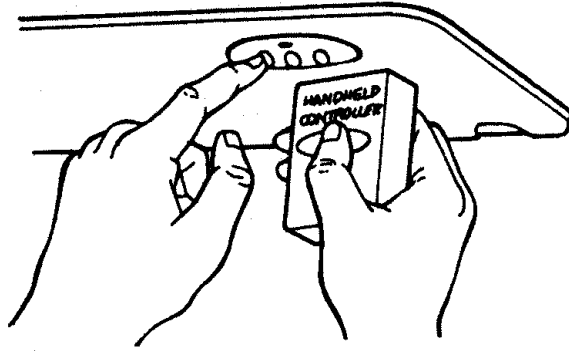

4. When the Universal Transmitter light begins to flash rapidly (this could take up to 60 seconds), release both buttons. You can now use your Universal Transmitter instead of the hand-held controller.

5. To program the other two buttons on your Universal Transmitter, skip step two and repeat steps 3 and 4.

NOTE: Be sure to keep your original hand-held transmitter for possible retraining if it becomes necessary to erase the Universal Transmitter.

Note to Canadian users: Prior to 1992, regulations required many hand-held controllers to stop transmitting after one or two seconds. Transmission will stop even though you continue to hold down the button, and even if the light on the hand-held transmitters remains lit. If you think you have one of these controllers, you should press and re-press the controller every two seconds without releasing the Universal Transmitter button. Release both buttons when the Universal Transmitter light begins to flash rapidly.

Operating the Universal Transmitter

! WARNING

Do not use the Universal Transmitter with any garage door opener that lacks safety "stop" and "reverse" features as required by federal standards.

To operate, press the appropriate button on the Universal Transmitter. The light will illuminate while the signal is being transmitted.

NOTE: The effective transmission range of the Universal Transmitter may differ from your hand-held transmitter.

Erasing the Universal Transmitter Channels

To clear the Universal Transmitter of all three previously stored frequencies, follow Step 2 of the *Programming the Universal Transmitter* section.

Console

Your vehicle may have a full console. The full console has the following features:

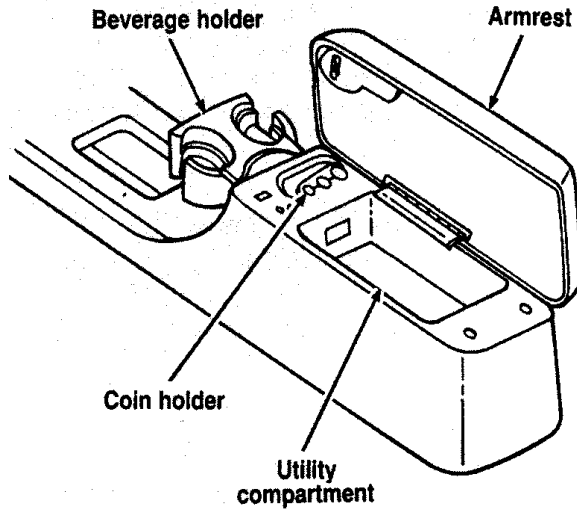

The features on the full console

Cupholder with full console

The cupholder provides a space for your cup.

Mini console cupholders

Six passenger vehicles are equipped with a mini console that is located within the ashtray panel. To open the panel, press on the front of it and release. It will open automatically. To close, push the panel back into place until it latches.

!WARNING

**Use only soft cups in the cupholder.
Hard objects can injure you in a
collision.**

Storage Compartments

Your vehicle has two map pockets on the panels of the front doors. The back of the front seats also have map pockets.

Trunk

Opening the Trunk Manually

Locate the trunk lock in the rear reflector to the right of the license plate to insert the key. Turn the key to the right to open the trunk.

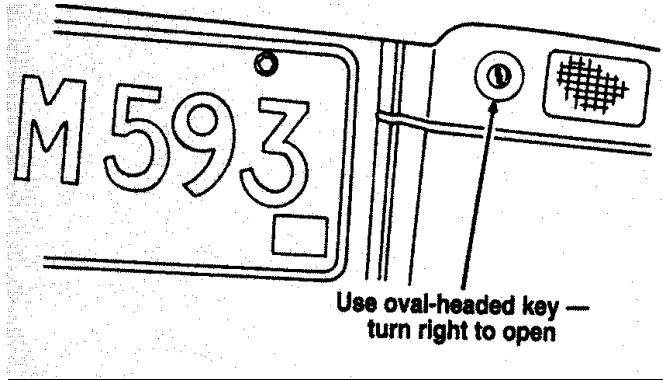

The trunk lock cylinder

Using the Power Trunk Release

You can use your power trunk release feature in three ways:

With your electric trunk release, you can open the trunk from inside your vehicle by pressing the TRUNK RELEASE button located on the driver side door. The TRUNK RELEASE button will only function when the vehicle is traveling under three mph (five km/h).

To open your trunk with the keyless entry system, press 5/6 on the keyless entry pad within five seconds of entering the keyless code.

You can also open the trunk by pressing the TRUNK button on the remote entry transmitter. To prevent inadvertent activation, the trunk button must be depressed twice within five (5) seconds to open the trunk.

Located on driver's door

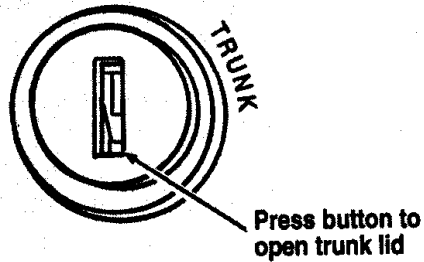

The remote control for the trunk

The trunk lid cannot be opened if your vehicle is moving faster than three mph (five km/h).

Cargo Storage System (If equipped)

Your vehicle may be equipped with a cargo storage system. It was designed to allow you to use all available space in your trunk while permitting easy loading and unloading.

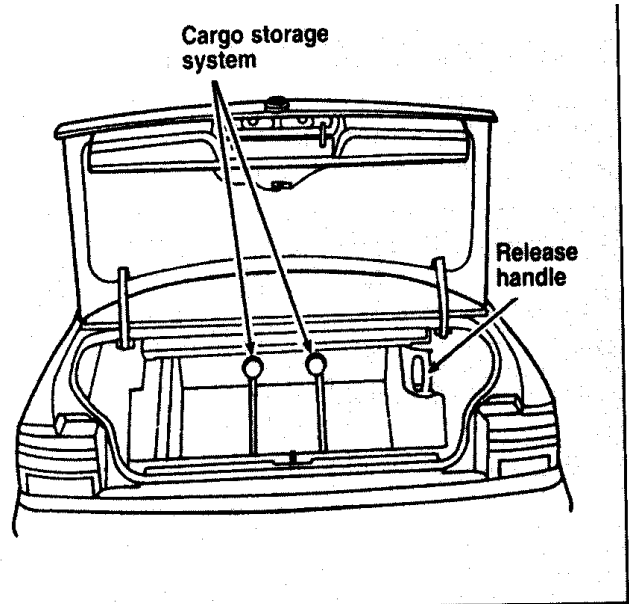

The cargo storage system

To operate:

Grasp and squeeze the release handle to move the cargo storage system rearward.

Place groceries, packages, etc. in the cargo storage system.

Grasp and squeeze the release handle to move the cargo storage system forward until it locks into place.

NOTE: The cargo storage system has three locking positions. Make sure the storage system is securely locked in place.

Remote Control Fuel Filler Door Release Button

Your vehicle has a remote control fuel filler door which cannot be opened from outside of the vehicle. To unlatch the fuel filler door, push the fuel door button on the driver side door. Refer to *Servicing Your Vehicle* in the Index for further information.

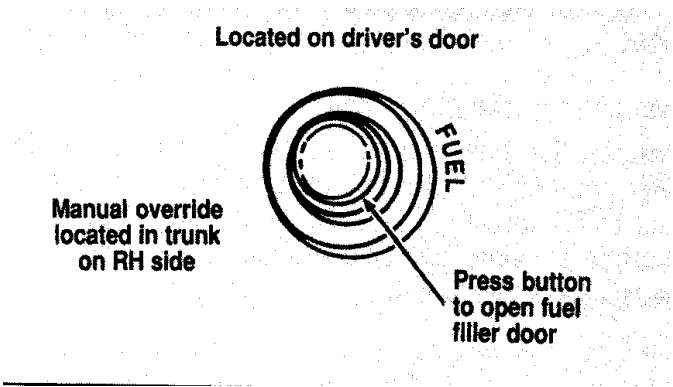

The remote control fuel filler door release button

Positive Retention Driver's Side Floor Mat

Installing the floor mat

Position the floor mat in foot well. Place mat eyelet over pointed end of retention post from the rear and rotate forward to install. Adjust floor mat position to allow proper operation of accelerator pedal and brake pedal.

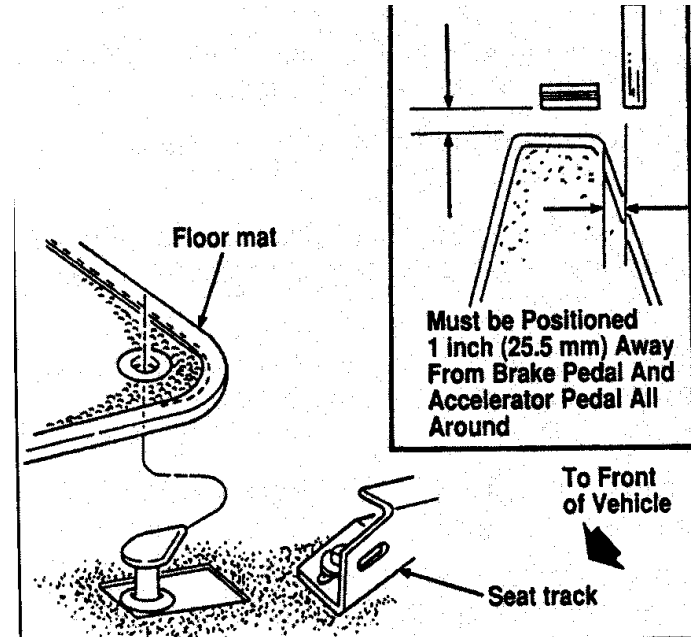

The positive retention floor mat

Removing the floor mat

Lift floor mat just forward of retention post and rotate rearward to disengage from retention post.

The Electronic Compass (If equipped)

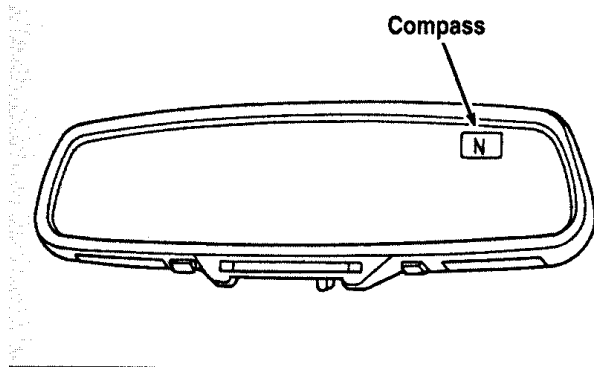

The electronic compass

The compass is mounted to the inside rear view mirror. The display is in the upper right hand corner of the mirror glass.

The display will show one of the following directions: N, NE, E, SE, S, SW, W, and NW. The brightness of the compass display is controlled by the instrument panel dimming switch.

Factors Affecting Compass Accuracy

Some things which can affect compass accuracy are large buildings, bridges, power lines, and powerful antennas. Keep radar detectors and other magnetically mounted devices as far away from the compass as possible. Sometimes after-market and dealer-installed moon roofs can affect the accuracy of the compass. Using automatic car washes can cause minor inaccuracies in the compass.

NOTE: Usually, when something affects the compass readings, the compass will correct itself after a few days of operating your vehicle in normal conditions. If the compass is still giving inaccurate

readings after a few days, perform a compass adjustment.

Compass-Calibration

1. For optimum calibration, switch off all non-essential electrical accessories (rear window defrost, heater/air conditioning, map lamps, wipers, etc.) and ensure all doors are shut.
2. Drive to an open, level area away from large metallic objects or structures.
3. Insert an appropriate diameter rod (paper clip) into the left switch access hole underneath the compass module and press gently for 1-2 seconds until "CAL" and a direction appear on the display.

4. Release the button and drive in a circle until "CAL" disappears from the display (approx. 2-3 circles).

Compass-Zone Adjustment

1. The zone setting is factory pre-set to Zone 8. Refer to the Zone Map in this manual to verify the correct compass zone setting for your geographical location.

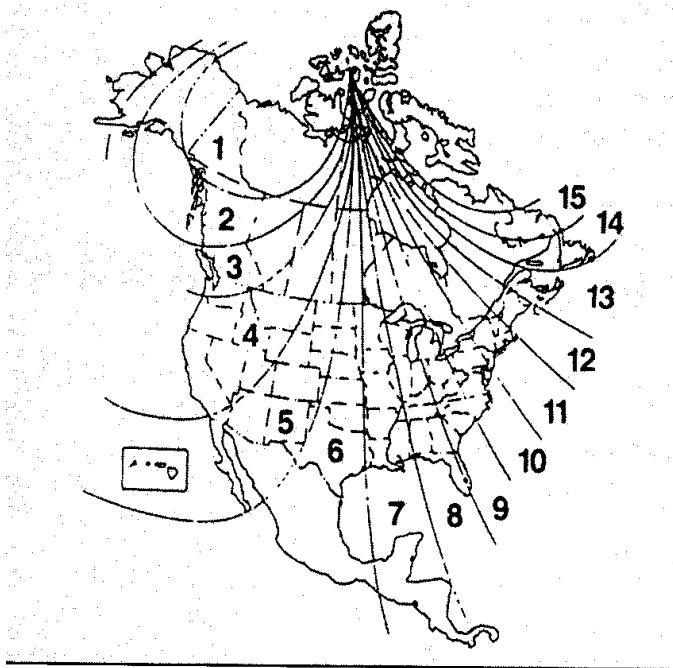

2. Insert an appropriate diameter rod (paper clip) into the right switch access hole underneath the compass module and gently press the right button for 1-2 seconds until "ZONE" and the current zone setting appear in the display.
3. Release the right button.
4. Pressing the right button repeatedly will cycle through all possible zone settings. Stop cycling when the correct zone setting for your location appears.
5. Releasing the button for 2 seconds will exit the zone entry mode.

Securitre (If equipped)

Securitires are designed to allow you to continue driving your Continental a limited number of miles when one of your vehicle's tires is at low or even zero air pressure.

At zero pressure, the Securitires will provide you with a minimum driving capability of approximately 20 miles (30 kms). How you drive and the actual amount of air pressure left in your tires will determine exactly how many miles can be driven.

To extend the mileage and help prevent damage to low or deflated tires, you should:

- not exceed 55 mph (90 km/h) and drive at a reduced rate of speed, if possible
- avoid excessive hard steering and braking maneuvers, if possible
- stop periodically to allow the tires to cool down

⚠ WARNING

If your vehicle is driven with a low tire, the tire itself may become very hot. Allow the tire and wheel to cool before attempting to change it.

Pressure Alert System

Each of your Securitires is monitored by a low tire pressure sensor. A warning will appear in the overhead console when the pressure in one of your tires drops below acceptable levels or if the system has malfunctioned.

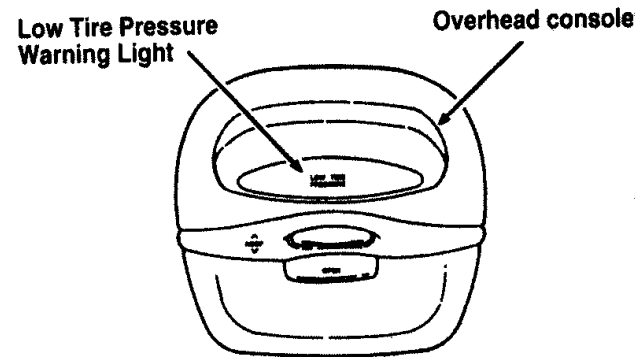

Low Tire Pressure Warning in the overhead console

THIS DEVICE COMPLIES WITH FCC RULES, PART 15. OPERATION IS SUBJECT TO THE FOLLOWING TWO CONDITIONS: (1) THIS DEVICE MAY NOT CAUSE HARMFUL INTERFERENCE AND (2) THIS DEVICE MUST ACCEPT ANY INTERFERENCE THAT MAY BE RECEIVED, INCLUDING INTERFERENCE THAT MAY CAUSE UNDESIRABLE OPERATION.

Maintenance Warning

The "Low Tire Pressure" warning will illuminate and stay on when one of your vehicle's tires drops below 18 psi (124 kps). The warning light will also come on and stay lit if the Pressure Alert System has malfunctioned.

If this warning appears, check the pressure in your tires at the earliest possible convenience and adjust any tire that is low to the recommended air pressure level. This information can be found on *the Service Station Information* page at the back of this manual or on the driver's door placard.

If the warning remains on after you have adjusted the tires to recommended air pressure levels, take your vehicle to an authorized Lincoln/Mercury dealer for service.

Flat Tire Warning

If the sensors detect a tire pressure lower than 10 psi (68 kps), the "Low Tire Pressure" warning will flash repeatedly in the overhead console and the message "Warning Low Tire Pressure" will be displayed in the Message Center, indicating an impending flat tire. If this condition occurs, your Securitire requires service as soon as possible. Refer to *Servicing Your Secutitires*.

NOTE: The Pressure Alert System will activate only when the vehicle is moving faster than 10 mph (15 km/h).

Servicing Your Securitires

⚠️ WARNING

Do not use aerosol tire inflator/sealer with Securitires. Doing so may damage the tire's pressure sensor.

If you cannot service your Securitire immediately, replace it with your mini-spare as soon as it is safe to do so.

Your mini-spare tire can be used until your Securitire has been repaired. See *Tires* in the *Servicing* chapter of this guide for more information on using the spare.

It is recommended that you always have your Securitires serviced by an authorized Michelin tire dealer. **Each Securitire is equipped with a pressure sensor around the wheel rim. This sensor could be damaged when removing and installing the tire.** Servicing a Securitire at

locations other than your Michelin tire dealer may adversely affect your warranty.

If you have questions concerning your Securitires or servicing, please call the Michelin Tire Information Line at 1-800-847-3435 or contact your local Michelin tire dealer.

Lincoln RESCU System (If equipped)

⚠️ WARNING

It is important that you understand the limitations of your Lincoln RESCU System prior to initiating an activation. See *Lincoln RESCU System Limitations* later in this chapter for details.

Quick Summary

- ❑ To utilize your vehicle's assistance request feature, **YOUR CELLULAR PHONE MUST BE ACTIVATED.**
- ❑ Roadside or emergency assistance can be requested whenever your key is in the RUN/START position and for two minutes after the vehicle is turned off.
- ❑ An assistance request is initiated by pressing either the tow truck or ambulance button located in the overhead console.
- ❑ When a button is pressed, a warning lamp located in the overhead console begins to flash and status messages are displayed on the vehicle's message center. (Messages are only displayed when your key is in the RUN/START position.)
- ❑ The vehicle's cellular phone automatically places a call to a 24 hour emergency response center.
- ❑ When contact is made, the vehicle sends an electronic data message to the response center's computer. This data message includes latitude and longitude coordinates obtained from the vehicle's positioning system.
- ❑ Once the data transmission is complete, the call is forwarded to a response center operator who confirms your location using a computerized map.
- ❑ The vehicle's cellular handset is locked-out, the phone is automatically placed in "hands free" mode and voice communication is established with the operator through the "hands free" microphone.
- ❑ Typically, voice communication with an operator is established within one minute after an assistance button is pressed.

- ❑ The operator verbally obtains details of Your situation and, if necessary, ties your vehicle into a three-way phone call with the United States Auto Club or local 911 or other emergency services to dispatch the appropriate assistance to your location.
- ❑ Once the situation has been appropriately handled, the operator will terminate the call, the system warning light will stop flashing and the system will be reset. In most situations, **ONLY** the response center can terminate an assistance request.

General Description

Lincoln's Remote Emergency Satellite Cellular Unit (RESCU) is designed to expedite roadside or emergency assistance to distressed motorists who are uncertain of their location and/or are uncertain of who to contact for assistance.

The Lincoln RESCU System utilizes Global Positioning System (GPS) technology and the

nation's cellular phone network to track vehicle location and, at the touch of a button, put you in voice contact with the Lincoln Security Response Center.

Two buttons in the overhead console will activate the system. A tow truck icon for roadside assistance and an ambulance icon for emergency assistance

identify the buttons.

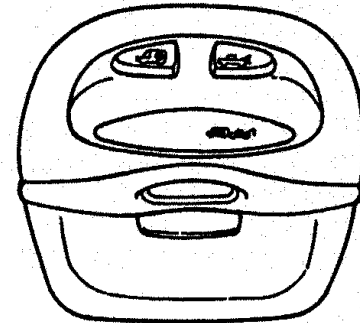

The Overhead Console

When you select a button, the vehicle's cellular phone will automatically place a call to the response center's central computer. Once contact is made, an electronic data message will be transmitted. This data message will include:

- Type of alarm (roadside or emergency)
- Vehicle Identification Number (VIN)
- Latitude and longitude coordinates
- Last recorded speed and direction of the vehicle
- Time tag identifying when last position was taken
- Call-back phone number

After the transmission is complete, the call is forwarded to an operator who will verify the details of the request and confirm the vehicle's location using computerized map.

Tow Truck Button (Roadside Assistance)

The tow truck button should be selected if roadside assistance is required. The feature should be used:

- when your vehicle runs out of gas
- when your vehicle needs a tow
- to acquire assistance in any non-emergency situation



The Roadside Assistance button

When this button is pressed, the Lincoln Security Response Center relays details of your situation and your location to the United States Auto Club (USAC) via a three-way phone call. The response center/USAC will:

- dispatch the appropriate service vehicle to your location.
- provide the service vehicle's estimated time of arrival.
- call back approximately three minutes after the service vehicle's estimated time of arrival to confirm that assistance has arrived.

Ambulance Button (Emergency Assistance)

The ambulance button should be selected if emergency assistance is required. This feature should be used:

- if you have been involved in an accident

- to report a crime or fire
- when medical attention is required
- to receive assistance in any emergency situation



The Emergency Assistance button

When this button is pressed, the Lincoln Security Response Center relays details of your situation and your location to local 911 or other emergency services via a three-way phone call. The response center/emergency services will:

- dispatch the appropriate emergency help to your location

- ❑ when appropriate, stay in direct phone contact with you until emergency help arrives
- ❑ notify pre-designated family contacts or friends of the emergency situation, if requested, or if no response is received from the vehicle.

NOTE: If You are certain of your location, a direct phone call to 911 or other emergency services may provide a faster response.

Activation and Deactivation

When either of the two Lincoln RESCU buttons is pressed, a warning light, located in the overhead console, will begin to flash and status messages will be displayed on the vehicle's message center, confirming an assistance request has been made. The warning light will continue to flash throughout the activation.



The RESCU Warning light

The system can be activated whenever your ignition key is in the RUN/START Position and for two Minutes after your vehicle is turned off. In most situations, the assistance request can **ONLY** be terminated and the system reset when a special tone is sent to the vehicle by the Lincoln Security Response Center. (See *Automatic Redial* later in this chapter for exceptions.) Operation will continue even if the vehicle is turned off during an activation (although visual feedback via the Message Center will not be available in this situation).

Cellular Phone Interface

During an activation, Lincoln RESCU takes control of the vehicle's cellular phone. If the phone is in use, THE CALL WILL BE TERMINATED and the Lincoln Security Response Center will automatically be dialed. The cellular handset becomes inoperative and all voice communication with the operator is accomplished via the cellular phone's "hands-free" microphone.

NOTE: When an activation is terminated, your phone is left unlocked, in the "ON" state and may not return to its previous system selection setting. It can be reprogrammed to your previous setting as desired.

Message Center Interface

During an activation, Lincoln RESCU communicates with the vehicle's Message Center. Status messages describing the sequence of steps being executed are displayed, allowing you to visually follow the activation process. The following messages are

typical of those displayed during an assistance request. They are shown in the order in which they would appear:

- ROADSIDE REQUEST or EMERGENCY REQUEST
- CALL IN PROGRESS
- RINGING RESPONSE CENTER
- SENDING LOCATION DATA
- DATA RECEIVED
- WAITING FOR OPERATOR

Once an assistance request is made, it will typically take less than one minute until contact is made with an operator. During voice communication the following messages will alternately toggle on the display:

- CID XXXXXXXXXXXX
- LAT XXXXXXXXXXXX

□ LON

□ HDG XX

These messages respectively are the customer identification number, vehicle latitude, vehicle longitude and heading. Under special circumstances, the operator may ask you to read the information being displayed on the Message Center.

If vehicle messages are being displayed on the Message Center (low washer fluid, low oil, door ajar, etc.), they must be cleared in order to view the LINCOLN RESCU messages. To clear the vehicle messages, press the Message Center RESET button, which is located to the right of the display. Continue pressing the button until all vehicle messages are cleared.

Automatic Redial

As described previously, when an assistance request is made, the vehicle's cellular phone automatically dials the Lincoln Security Response Center's central computer and attempts to send an electronic data

message. Occasionally, it can be difficult for the computer to recognize the message if the cellular connection is weak or noisy. If the transmission of the message is unsuccessful, the data call will be terminated and the message "REDIAL IN PROGRESS" will be displayed on the Message Center. A second call will automatically be placed which bypasses the response center's computer and is forwarded directly to an operator.

Similarly, if the cellular call is disconnected by the network prior to receipt of the termination tone, another call to the response center will also automatically be dialed. The message "REDIAL IN PROGRESS" will be displayed on the Message Center and voice communication with an operator will be restored.

NOTE: During redial calls, full control of the cellular phone is returned to you. Pressing either the "PWR" or "END" button on the cellular handset will terminate the assistance request and reset the system.

Location Data Retransmit Capability

During an activation, the Lincoln Security Response Center operator has the capability to initiate a retransmission of the electronic data message. This may be necessary to ensure a more precise determination of vehicle location or to track a vehicle that is moving. To accomplish the retransmit, a special tone is sent to the vehicle by the response center. In this situation you will temporarily lose voice contact with the operator and the messages "SENDING LOCATION DATA" and "DATA RECEIVED" will respectively be displayed on the Message Center. After the data retransmission is complete, voice communication will be restored and the CID, LAT, LON and HDG message will again alternately toggle on the Message Center display.

Global Positioning System

Vehicle location is continuously updated via Global Positioning System (GPS) technology. GPS was developed by the U.S. Department of Defense for worldwide navigational and positioning purposes. It utilizes a constellation of 24 orbiting satellites located more than 20 thousand kilometers above the earth. At any given time, several of the 24 satellites should be visible to the vehicle's GPS receiver. Based on the time for signals emitted by these satellites to reach the receiver, an on-board computer will determine the vehicle's location, typically within 100 feet. In addition to latitude and longitude, the system also determines heading and speed.

Vehicle positioning information is relayed to the Lincoln Security Response Center **ONLY** during roadside or emergency requests. The response center will not be able to track your location while in an inactive state.

Lincoln RESCU System Limitations

Service restricted to 48 contiguous states

Your Lincoln RESCU System can be activated anywhere within the 48 contiguous states. If an activation occurs outside of this region, the Lincoln Security Response Center will not be able to assist you.

Inoperative if cellular phone inactive or inoperative

Lincoln RESCU utilizes your vehicle's cellular phone and will not operate if cellular service has not been activated or if the phone is inoperative.

Inoperative if battery discharged or disconnected

Lincoln RESCU is powered by the vehicle's battery and will not operate if the battery is discharged or disconnected.

Potentially inoperative if vehicle involved in accident

If the vehicle is involved in an accident, some components could be damaged, rendering your Lincoln RESCU System inoperative.

Positioning capability degraded if satellite signals obstructed

Vehicle positioning is accomplished by receiving and interpreting signals transmitted by satellites. If the signals are obstructed, positioning capability could be degraded or lost. This situation will be most prevalent in urban areas populated with tall buildings. Tunnels, underpasses, parking garages, trees, and similar structures could also adversely affect positioning performance. Under these conditions, the system will operate but the response center could have difficulty identifying your current location. (The last valid position obtained before the obstruction is retained, however, and will be sent.) The operator may depend on you to provide verbal information regarding vehicle location.

Positioning capability temporarily degraded after battery reconnect

When your vehicle is started, the Lincoln RESCU GPS receiver begins the process of determining vehicle location. The receiver will search the sky and attempt to acquire signals from all visible satellites. A real-time clock and an almanac containing detailed information about the satellite constellation are stored in the on-board computer's memory and are used to expedite the search. If the vehicle's battery is disconnected, the clock memory is erased and time and date are lost. Once the battery is reconnected, it could take approximately 15 minutes to reacquire the clock and for positioning capability to be restored. During this time, the system will operate but the response center will not be able to identify your location. In this situation, the operator will depend on you to provide verbal information regarding vehicle location.

Inoperative if cellular signal marginal or unavailable

Since the Lincoln RESCU System utilizes the vehicle's cellular phone, it can only be operated in geographical areas with cellular coverage. Although approximately 90 percent of the U.S. population lives and works in cellular coverage areas, there are various rural or mountainous areas where coverage is marginal or does not exist. If an activation occurs in this situation, the messages "NO CELLULAR SIGNAL" and "WAITING TO ACQUIRE" will alternately be displayed on the Message Center. If after several attempts cellular service cannot be acquired, the message "UNABLE TO PLACE CALL" will be displayed, the assistance request will be terminated and the phone will return to its normal operating mode.

Inoperative if cellular system busy

In a particular area, the local cellular system can only handle a limited number of cellular calls at one time. Once volume has reached the maximum limit, additional callers are denied access. If an activation occurs in this situation, the messages "CELLULAR SYSTEM BUSY" and "PLEASE WAIT" will alternately be displayed on the message center. If after several attempts a cellular channel cannot be acquired, the message "UNABLE TO PLACE CALL" will be displayed, the assistance request will be terminated and the phone will return to its normal operating mode.

Incompatible with cellular PIN feature

Some cellular carriers offer custom phone numbers that are assigned a personal identification number (PIN). In this situation, the user is required to enter the pin with any phone calls made over the network. The Lincoln RESCU System is not compatible with the pin feature. At the time your phone is activated, ask your carrier to assign you a

phone number that does not require a personal identification number entry. If you have difficulty obtaining a non-PIN number, contact your dealer or call the Ford Cellular System Clearinghouse at 1-800-367-3357 for assistance.

Incompatible or performance limited with certain cellular provider features.

Some cellular carriers offer customers various optional features with their cellular service. Several of these features are not compatible or could potentially limit the performance of your Lincoln RESCU System. The cellular features that should be avoided to ensure maximum system performance include: no outgoing calls, hotline, call forwarding, no incoming calls, npa restrictions, busy/no answer transfer, and call waiting. Because carriers are regularly making new features available to the customer, this list may not be complete. Contact your dealer for assistance if you are unsure if a particular cellular feature is compatible with your Lincoln RESCU System.

Potential limitations if activated outside home cellular region

At the time you receive your vehicle (or shortly after), you will need to select a cellular carrier and activate your phone. If desired, carrier selection can be arranged through your dealer. This carrier is usually local to your region and will handle call processing and billing services for your cellular telephone. In order to use your phone when traveling outside your home cellular region, the services of the carriers local to the new area will be required. If your home carrier does not have an agreement with the new local carrier, your phone calls could be forwarded to an operator and you may be required to provide a credit card number before your call is processed. If an activation occurs call in this situation, the initial call will be terminated and a second call which bypasses the response center's computer will be placed. **UNLIKE DURING THE FIRST CALL ATTEMPT, YOUR CELLULAR HANDSET WILL NOT BE LOCKED DURING THE SECOND CALL, SO YOU WILL HAVE THE**

OPTION OF TERMINATING THE ASSISTANCE REQUEST AT ANY TIME BY PUSHING EITHER THE "PWR" OR THE "END" BUTTON ON THE CELLULAR HANDSET. If the second call is not terminated, it will be forwarded to a local cellular carrier operator. In this situation, you can provide the operator with the number you are dialing (Lincoln Security Response Center at 1-800-334-1327) and your credit card number or ask to be connected to the local 911 or other emergency services.

Registration Requirement

You are required to register with the Lincoln Security Response Center shortly after receiving your vehicle. The registration process is simple and can be accomplished by calling the Lincoln Security Center at 1,800-334-1327. Alternatively, the registration process can be completed on-line during an acquaintance period activation. (*See "Acquaintance Activations" later in the section for details.*) The information requested will aid in servicing you more efficiently during the assistance request.

Optional Password Selection/False Activations

At the time of your registration, you will be given the option of establishing a user password. All aspects of your service will be identical regardless of your password decision except the way false emergency activations are handled.

If established, the password will be requested by the operator to confirm an emergency activation was initiated in error. If no password or an incorrect password is given, the response center's operator will seemingly terminate the call but actually stays on the line and sends police to the last calculated vehicle location (this could be useful in duress situations). It is very important that you remember your password to prevent false dispatches. Similarly, it is also important to provide the password to any other individuals who will be driving the vehicle or who may have need to activate the system.

If you decide not to establish a password, simply indicate to the operator that the emergency

assistance request was initiated in error and the call will be terminated.

In either case, if an activation (roadside or emergency) occurs and the operator cannot establish voice communication, police assistance will be dispatched to the vehicle.

NOTE: Information regarding changing or retrieving lost passwords can be obtained by contacting the Lincoln Security Response Center at 1-800-334-1327.

Acquaintance Activations

It is required that you initiate an acquaintance activation shortly after receiving your vehicle and having your phone activated. An acquaintance activation is initiated by pressing either the roadside or emergency assistance button. When voice communication is established with the Lincoln Security Response Center, indicate that you are a new user and the operator will follow special acquaintance period support procedures which are

intended to familiarize you with your Lincoln RESCU system. As described previously, the acquaintance call can also be used to complete the registration for new customers.

Service Charges

For four years, beginning with your vehicle's warranty period, you will be entitled to unlimited activations without facing service charges. (These activations should be made only when emergency or roadside assistance is required.) You will be responsible, however, for any charges imposed by your cellular phone carrier for the 1-800 phone call to the Lincoln Security Response Center. After your initial service period expires, you may be required to pay a monitoring service fee. Your dealer can provide you with specific information regarding post initial service period fees.

Relinquishing your vehicle

At the time you relinquish your vehicle, it is important that you contact the Lincoln Security Response Center at 1-800-334-1327 and cancel your security service. Personal information provided to the response center at the time of your registration will be removed from the vehicle's file.

Electronic Sound Systems

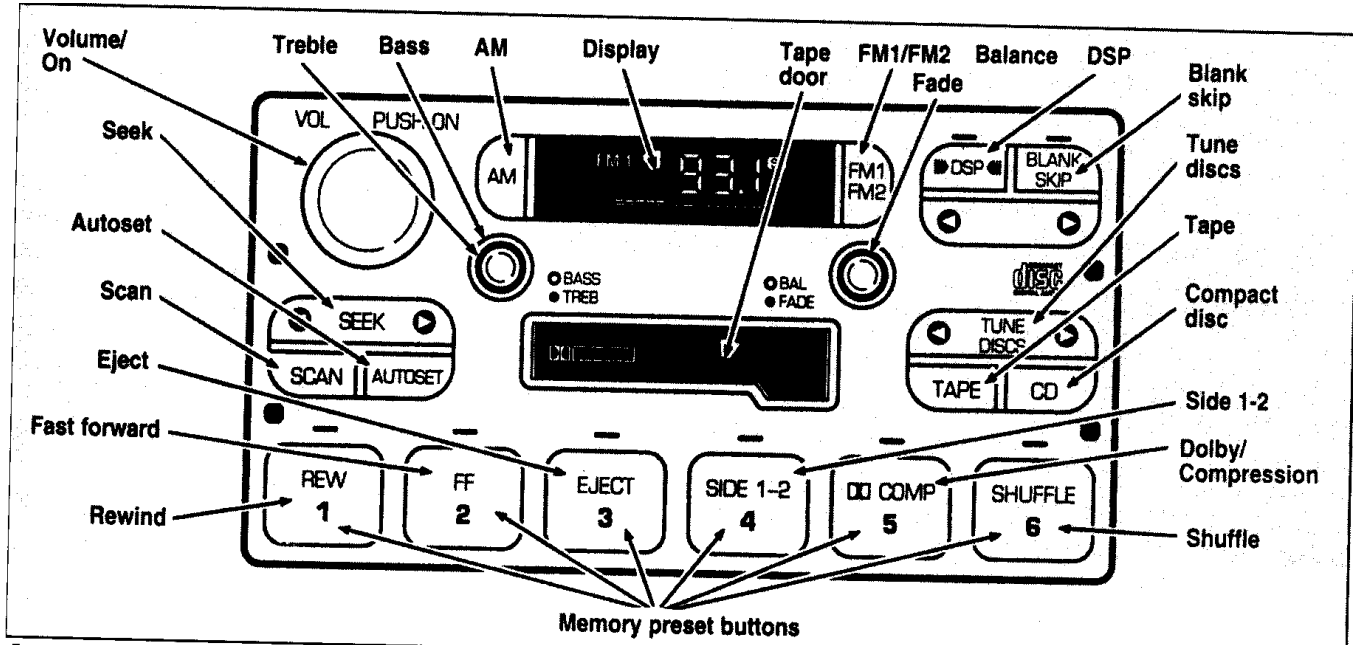

Luxury Audio System (Digital)

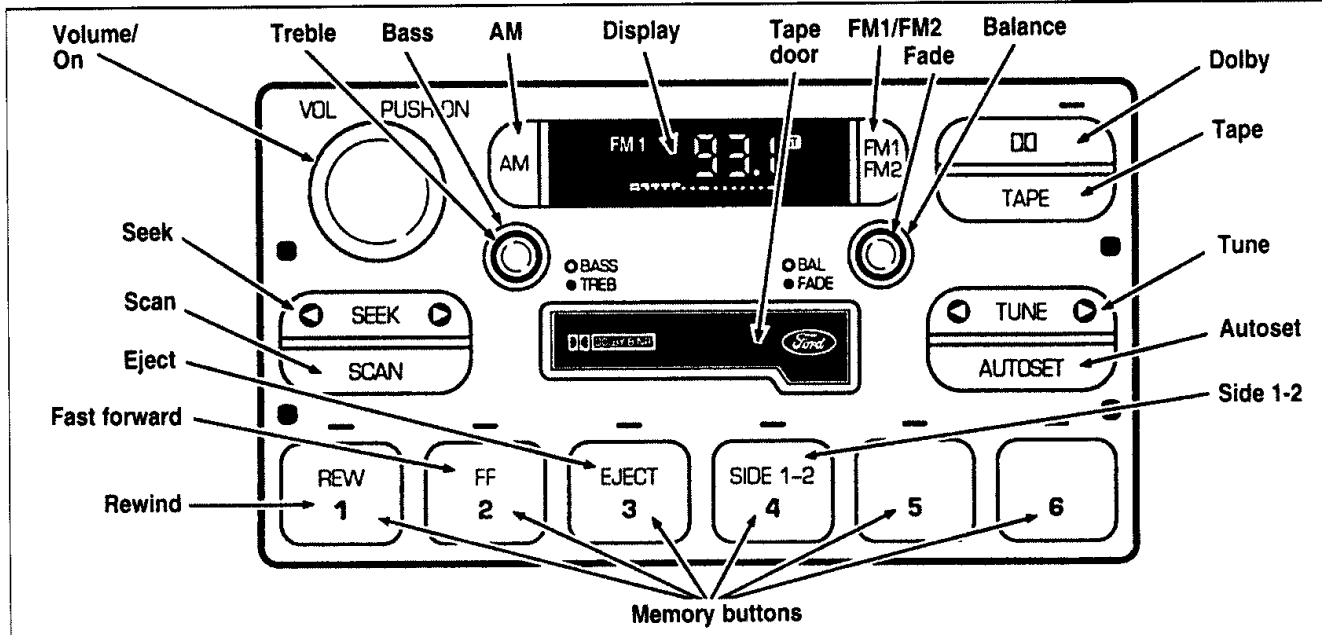

Luxury Audio System (Analog)

Luxury Audio System

Using the Controls on Your New Radio

How to turn the radio on and off

Press the "VOL/PUSH ON" knob to turn the radio on. Press again to turn it off.

How to adjust the volume

Turn the "VOL/PUSH ON" knob clockwise to increase the volume and counter-clockwise to decrease the volume.

NOTE: If the volume is set above a certain level when the ignition is turned off, the volume level will reset to a "nominal" listening level when the ignition switch is turned back on. However, if the radio is turned off with the "VOL/PUSH ON" knob, the volume will not reset and will stay at the same level when the radio is turned back on.

Selecting the AM or FM frequency band

Push the "AM" or "FM1/FM2" button to select the desired frequency band. Pushing the "FM1/FM2" button more than once will alternate between FM1 and FM2. These functions are used with the station memory buttons described under *How to tune radio stations*.

HOW to tune radio stations

There -are four ways for **you** to tune in a particular station. You can use the "TUNE", "SEEK", "SCAN" or memory buttons.

Using the "TUNE" function

You can change the frequency up or down one increment at a time by Pressing and releasing either the left (◀) or-right (▶) side of the "TUNE" or "TUNE DISCS" button. To change frequencies quickly, press and hold down either the right or left side of the button.

Manual tuning adjusts your radio to any allowable broadcast frequency, whether or not a station is present on that frequency. (See *All About Radio Frequencies* in this section.)

□ Using the "SEEK" function

Press the right (*) side of the "SEEK" button to select the next listenable station up the frequency band. Press the left (.4) side of the button to select the next listenable station down the frequency band. By holding the button down, listenable stations can be passed over to reach the desired station.

□ Using the "SCAN" function

Pressing the "SCAN" button will begin the scan mode up the frequency band, stopping on each listenable station for approximately five seconds.

To stop the scan mode on the presently sampled station, press the "SCAN" button again.

□ Setting the station MEMORY PRESET buttons

Your radio is equipped with 6 station memory buttons. These buttons can be used to select up to 6 preset AM stations and 12 FM stations (6 in FMI and 6 in FM2)

1. Select a band, then select a frequency.
2. Press one of the memory buttons and hold until the sound returns and the lamp above the memory button lights up. That memory button is now set.
3. Follow the above steps for each memory preset button.

NOTE: Custom memory presets can be recalled using the keyless entry system. See *Memory Profile System* in the *Features* chapter.

Using the Automatic Memory Store feature (“AUTOSET”)

If the memory buttons have been set, either by using the Auto Memory Load feature or if you have set them manually, the system is prepared to let you use a convenient feature called **Automatic Memory Store**.

With Auto Memory Store, you can continually set strong stations into your memory buttons without losing your originally set stations. Your radio will automatically set your memory buttons to the strong local stations.

Activate Auto Memory Store by pushing the "AUTOSET" button once. Your radio will set the first six strong stations of the band you are in (AM, FMI or FM2) into the memory buttons. The display will flash "AUTO" and display the autoset icon "A" while the stations are being set in the memory buttons.

NOTE: If there are less than six strong stations in the frequency band, the remaining unfilled buttons will store the last strong station detected on the band. After all stations have been filled, the radio will begin playing the station stored on memory button 1.

To deactivate the Auto Memory Store mode and return to the manually-set memory button stations, simply push the "AUTOSET" button. Display will show "AUTO" then "OFF". The next time Auto Memory Store is activated on that band, the radio will store the next set of six strong stations.

Adjusting the tone balance of your radio

- Increasing or decreasing bass and treble response Push the "BASS/TREB" popout knob to gain access to the bass and treble controls. Bass control allows you to adjust the lower, bass frequencies to your preference. The outer ring of the "BASS/TREB" knob adjusts the bass (turn clockwise to increase bass; counterclockwise to decrease bass).

Treble control allows YOU to adjust the higher, treble frequencies of your radio to your preference. The inner ring of the "BASS/TREB" knob adjusts the treble (turn clockwise to increase treble; counterclockwise to decrease treble).

□ Adjusting speaker balance and speaker fader

Push the "BAL/FADE" popout knob to gain access to the speaker balance and fader controls. Balance control allows YOU to adjust the sound distribution between the right and left speakers. The outer ring of "BAL/FADE" knob adjusts the speaker balance control. (Turn clockwise to shift the sound to the right speakers, and turn left counterclockwise to shift the sound to the speakers.)

Fade control allows YOU to adjust the sound distribution between the front and rear speakers. The inner ring of the "BAL/FADE" knob adjusts the speaker fader. (Turn clockwise to shift the sound to the rear speakers, and turn counterclockwise to shift the sound to the front speakers.)

Using the Digital Signal Processing (DSP) Feature

Push the "(▶DSP◀)" button to activate the feature. The display will indicate Which signal mode is in effect. To change the signal mode press either the left (◀) or right (▶) side of the selector button (located under the "(▶DSP◀)" button).

The following signal modes May be selected:

1. "HALL" - Rectangular concert hall capacity of about 2,000.
2. "CHURCH" - Church with a high vault.

3. "JAZZ" - Jazz club with clearly reflected sounds.
4. "STADIUM" - Outdoor stadium with a capacity of about 30,000.
5. "NEWS" - "Voice-only" type of sound with a limited audio band.

To deactivate the DSP feature, press the "(▶DSP◀)" button again.

Delayed Accessory Feature

If the ignition is turned off while the radio is on, the radio will continue to play for up to ten minutes or until a door is opened.

Speaker Locations

Your Ford JBL sound system is equipped with a total of ten speakers: two speakers in each of the four doors and two subwoofers located in the rear package tray.

Your Antenna

Antennas for both AM and FM reception are hidden in the back glass of your vehicle. There is an internal antenna module that will switch between AM and FM, when bands are changed, for maximum reception performance.

NOTE: Do not attempt to adapt any other type of antenna system to your audio system.

Using the Controls of Your Cassette TapePlayer

NOTE: Radio power must be on to use the cassette tape player.

How to insert a tape

Your cassette tape player is equipped with power loading. Once you insert a tape and push slightly (with the **open edge to the right**), the loading mechanism draws the tape the rest of the way in and play will begin after a momentary tape tightening process. Display indicates "TAPE" while tape is playing.

If the player is in the tape mode but not in Play, pressing the "TAPE" button will activate play. If the "TAPE" button is pressed with no tape inserted, the display will flash "NO TAPE".

How to locate a desired track on the tape

There are six ways to quickly locate a desired selection on the tape. You can use the fast forward, rewind, Blank Skip, "SEEK", "SCAN" or "SIDE 1-2" functions. Following are brief descriptions of each:

Fast forwarding the tape

To fast forward the tape, press the "FF" button. The radio will play while the tape is in fast forward. The light above the "FF" button will blink while in the fast forward mode. Press "FF" again or press the "TAPE" button to stop fast forwarding. At the end of the tape, the direction automatically reverses and plays the other side of the tape.

Rewinding the tape

To rewind the tape, press the "REW" button. The radio will automatically begin playing while the tape is rewinding. The light above the "REW" button will blink while in the rewind mode. Press "REW" again or press the "TAPE" button to stop rewinding.

Using the "SEEK" function with your cassette tape player

While in the tape mode, push the right (▶) side of the "SEEK" button to seek forward to the next selection on the tape. Push the left (◀) side to restart a currently playing tape selection.

Using the "Blank Skip" function with your cassette tape player

Press the "Blank Skip" button to activate the blank skip mode. After approximately 20 seconds of blank program, the tape will seek forward to the next program.

- Using the "SCAN" function with your cassette tape player

Pushing the "SCAN" button will begin the forward scan mode on the tape currently playing, stopping on each tape selection for approximately eight seconds.

To stop the scan mode on the presently sampled tape selection, press the "SCAN" button or the "TAPE" button.

- How to change the side of the tape being played

The alternate side of the tape can be selected by pressing the "SIDE 1-2" button.

How to eject the tape

To stop the tape and eject the cassette, press the "EJECT" button. The tape will eject only when in the tape mode. The cassette **cannot** be ejected when the radio is playing an "AM" or "FM"

station. The system will revert to radio mode when the cassette is ejected.

How to store the tape

Press the "AWFM" button to stop the tape player and resume radio play.

Using the Dolby Ö B noise reduction feature

NOTE: Noise reduction system manufactured under license from Dolby Labs Licensing Corporation. "Dolby" and double-D symbol are trademarks of Dolby Laboratories Licensing Corporation.

Push the button to activate. When activated, the light above the button will be illuminated,

Tape error messages

Your cassette tape player is equipped to diagnose certain problems you may experience. Error codes are as follows:

TD E1 - Radio tries to change sides of tape 3 times in a 10 second span. push "EJECT" and try another tape. if problem persists, refer problem to qualified personnel for service.

TD E2 - Tape eject failure. Radio tries to eject tape and it will not eject. push "EJECT" to eject tape. if the tape Will not eject, refer problem to qualified personnel for service.

TD E3 - Loading error. push "EJECT" to eject tape. Reload tape. If the same error code appears in the display, try another tape.

Tips on Caring for the Cassette Player and Tapes

In order to keep your cassette tape player performing the Way it was meant to, read and follow these simple precautions:

- ❑ Using a Ford Cassette Cleaning Cartridge to clean the tape player head after 10-12 hours of play will help maintain the best playback sound and proper tape operation.

- ❑ Only cassettes that are go minutes long or less ger than go minutes should be used. Tapes longer than 90 minutes are thinner and subject to breakage or may jam the tape player mechanism.
- ❑ Protect cassettes from exposure to direct sunlight, high humidity and extreme heat or cold. If they are exposed to extreme conditions allow them to reach a moderate temperature before playing.
- ❑ If a tape is. loose inside the cassette; tighten it by putting, your finger or a pencil into one of the holes and turning the hub until the tape is tight.
- ❑ Loose labels on cassette tapes can become lodged in the mechanism. Remove any loose label material before inserting a cassette.
- ❑ Do not leave a tape in the cassette tape player when not in use. High heat in the vehicle can cause the cassette to warp.

Ford 6-CD Changer

Introduction

The Ford 6-CD Changer is mounted in your console and holds 6 CDs, all controlled by using buttons on your Luxury Audio System.

Be sure to read all of the information provided on the following pages to get the most out of this system.

Loading Instructions

1. Open Compact Disc Changer unit by sliding door to the right (Figure 1).

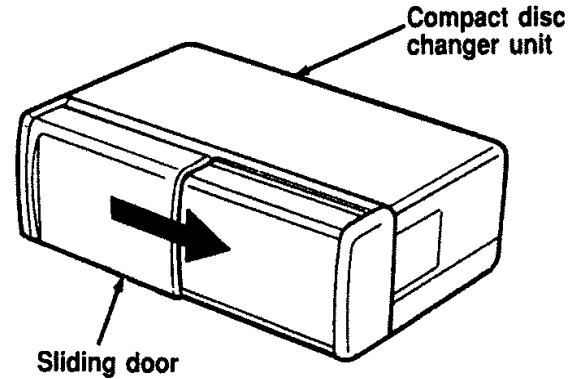



Figure 1

2. Push the  button to eject the disc "magazine" (holds 6 discs) (Figure 2).

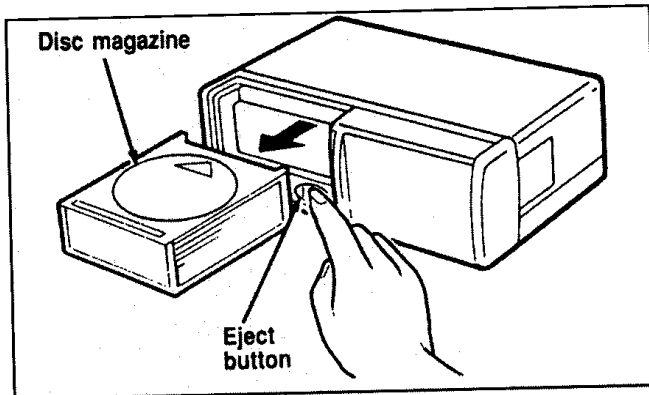

Figure 2

3. Load discs into the disc magazine slots (numbered I through 6) one at a time with labeled surfaces upward, starting with bottom slot number I (Figure 3).

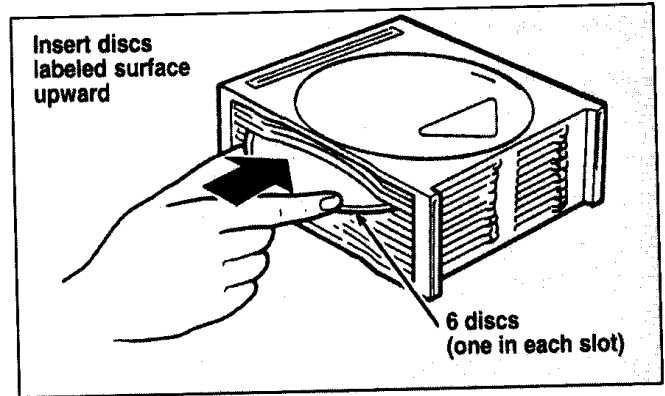

Figure 3

4. Insert loaded disc magazine into chamber unit with the arrow on top of the disc magazine pointing toward the changer (Figure 4). Make sure magazine is fully inserted into changer.

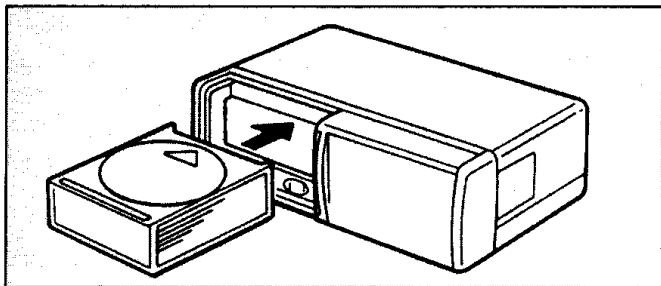

Figure 4

NOTE: To remove one or more compact disc(s) from the disc magazine, push the corresponding lever(s) to the back. Disc(s) will partially come out for easy removal.

5. Close unit by sliding changer panel door to the left.

The Compact Disc Changer unit is now ready to play using the controls of your Luxury Audio System.

How to Operate the Ford 6-CD Changer Using the Controls on the Radio

If your vehicle is equipped with the Ford 6-CD Changer System, you can operate it through the controls of your Luxury Audio System.

Several of the controls on the radio operate in the same manner in CD mode as they do in radio or cassette mode: turning the power on, volume control and adjusting the bass, treble, speaker balance or fade.

How to begin CD Changer play

NOTE: Radio power must be on to operate the Compact Disc Changer.

Push the "CD" button to begin CD play. The CD Changer will automatically begin playing the first track (selection) of the first disc loaded in the unit. The display will indicate "CD-#.#" for disc number then display "TR-##" for track number, then "DD-TT" for disc number and track number.

How to change the disc being played

When in the CD mode, you can change discs by pressing the right (pop.) side of the "TUNE DISCS" button (to select the next disc) or the left (▶) side of the "TUNE DISCS" button (to select the next disc) or the left (◀) side of the "TUNE DISCS" button to select the previous disc). Play will begin on the first track of the selected disc.

When either side of the button is pressed and held, the CD changer will continue fast-forwarding or reversing through the discs in the disc magazine. During these functions, the display will indicate the disc number.

How to change the track being played

Press the right (▶) side of the "SEEK" button to seek forward to the next track of current disc. After the last track has been completed, the CD player automatically wraps back to the first track of the current disc.

Press the left (◀) side of the SEEK button to seek in reverse to the previous track on the current disc. If a selection has been playing for three seconds or more and you press the left (◀) side of the SEEK button, the CD Changer will replay that selection from the beginning.

Operating the CD Compression feature

The compression feature will bring soft and loud passages closer together for a more consistent listening level.

To turn the compression on, press the #5 "□□/COMP" button. (While in the CD Changer mode, the Dolby button controls the compression function.) When the compression feature is activated, the display will indicate "C". Press again to deactivate.

Operating the Shuffle feature

The shuffle feature on your CD player allows you to listen to your disc selections in a different order. When this feature is activated, your CD player will randomly select and play tracks on the disc.

Press the "SHUFFLE" button to turn on, press it again to turn off. When on, the light above the "SHUFFLE" button will illuminate.

Operating the "SCAN"function

Press the "SCAN" button to enter the scan mode. The CD player will begin scanning the disc, stopping on each listenable track for approximately an eight second sampling. This continues until you press the "SCAN" button a second time.

Operating the Shuffle and Scan features simultaneously

Both the shuffle and scan features can be activated simultaneously. In this mode, the player will randomly pick a selection and play the first eight seconds. This process is continued until either the "SCAN" button or "SHUFFLE" button is pressed a second time.

How to stop CD play

While in CD Changer mode, press the EJCT, AM or FMI/FM2 button to stop CD play and resume radio play. Also, loading a cassette into the cassette deck will stop CD play and begin cassette play.

Balance control allows you to adjust the sound distribution between the right and left speakers. Push the "AUDIO" button repeatedly until the display reads "BAL." Push the right (+) side of the "VOLUME" button to shift the sound to the right speakers, and push the left (-) side to shift the sound to the left speakers.

How to take care of and clean the CD Changer and discs

To ensure the continued performance of your CD Changer carefully read the following precautions:

- Always handle a disc by the edge. Never touch the playing surface.
- Before playing, inspect all discs for any contamination. If needed, clean discs with an approved disc cleaner, such as the Discwasher® Compact Disc Cleaner or the Allsop® 3 Compact Disc Cleaner, by wiping from the center out to the edges. Do not use a circular motion to clean.
- Do not clean discs with solvents such as benzine, thinner, commercially available cleaners or antistatic spray intended for analog records.
- Do not expose the discs to direct sunlight or heat sources for an extended period of time.

- Do not insert more than one disc into each disc slot of the disc magazine. Doing so may damage the discs, disc magazine or the disc changer.
- Do not insert anything other than discs into the disc magazine.

! WARNING

The laser beam used in the compact disc player is harmful to the eyes. Do not attempt to disassemble the case.

CD Error Messages

Your system is equipped to diagnose certain problems you may experience. The error codes are:

- **CD E1** - Mechanism error.
- **CD E2** - Focus error.
- **BAD CD** - Disc unreadable.

- **TOO HOT** - Mechanism over 167' Farenheit, allow to cool before playing.
- **NO CD** - Empty slot or magazine.
- **NO DJ** - CD Changer not connected or not communicating.

Common Operating Conditions of the CD Player

The following information is designed to help you recognize typical situations that could be mistakenly interpreted as mechanical malfunctions of the disc player.

- A disc is already loaded.
- The disc is inserted with the label surface downward.
- The disc is dusty or defective.
- The player's internal temperature is above 167°F (75°C). Allow the player to cool off before operating.

- Different manufacturers of compact discs may produce discs with different dimensions or tolerances, some of which may not be within industry standards or in accordance with the CD format. Because of this, a new disc that is free of dust and scratches could be defective and may not play on your Ford Compact Disc Player.

If play does not begin after the CD button is pushed:

- The radio is not on.
- The unit is in the stop mode.
- Moisture may have condensed on the lenses within the unit. If this occurs, remove the disc and wait approximately an hour until the moisture evaporates.

If the sound skips:

- ❑ Badly scratched discs or extremely rough roads will cause the sound to skip. Skipping will not damage the disc player or scratch the discs.

Common Radio Reception Conditions

Several conditions prevent FM reception from being completely clear and noise-free, such as the following:

Distance/Strength

The strength of the FM signal is directly related to the distance the signal must travel. The listenable range of an average FM signal is approximately 24 miles (40 km). Beyond this distance, the radio is operating in a "fringe" area and the signal becomes weaker. Also, "Signal Modulation" is used by some stations to increase their "loudness" relative to other stations. The difference in loudness can be a result of signal modulation as well as signal strength.

Terrain

The terrain (hilly, mountainous, tall buildings) of the area over which the signal travels may prevent the FM signal from being noise-free.

Repeated pops and hisses which are heard during an otherwise clear broadcast can occur near the station because of the "line of sight" characteristic of FM radio waves.

If there is a building or large structure between the antenna and station, some of the signal "bends" around the building, but certain spots receive almost no signal. Moving out of the "shadow" of the structure will allow the station to return to normal.

When the radio waves are reflected off objects or structures, the reflected signal cancels the normal signal, causing the antenna to pick up noise and distortion. Cancellation effects are most prominent in metropolitan areas, but also can become quite severe in hilly terrain and depressed roadways.

To minimize these conditions, a stereo/mono blend circuit has been incorporated into this system. This feature automatically switches a weak stereo signal to a clearer monaural signal, which improves the quality of reception.

Several sources of static are normal conditions on AM frequencies. These can be caused by power lines, electric fences, traffic lights and thunderstorms.

Another reception phenomenon is **Strong Signal Capture and Overload**. This can occur when listening to a weak station and when passing another broadcast tower. The close station may capture the more distant station, although the displayed frequency does not change. While passing the tower, the station may switch back and forth a few times before returning to the original station.

When several broadcast towers are present (common in metropolitan areas) several stations may overload the receiver, resulting in considerable station changing, mixing and distortion.

Automatic gain control circuitry for both AM and FM bands has been incorporated into this system to reduce strong signal capture and overload.

All About Radio Frequencies

The Federal Communications Commission (FCC) and the Canadian Radio Telecommunications Commission (CRTC) establish the frequencies that AM and FM radio stations may use for their broadcasts. The allowable frequencies are, AM: 530, 540... 1600, 1610 kHz in 10 kHz steps; FM: 87.9, 88.1... 107.7, 107.9 MHz in 0.2 MHz steps.

Not all frequencies will be assigned to a given area. This radio will tune to each of these frequencies using manual tune and no fine tuning is necessary as radio stations may not use other frequencies.

Some FM radio stations advertise a "rounded-off" frequency which is not the frequency they actually broadcast on. For example, a radio station that is assigned a frequency of 98.7 MHz may call itself "Radio 99" even though 99.0 MHz is not an allowable FM broadcast frequency.

Important Warranty and Service Information

About Your Warranty

Your sound system is warranted for four years or 50,000 miles (whichever occurs first). Consult your vehicle warranty booklet for further information.

Servicing Your Audio System

At Ford Electronics, we stand behind our audio systems with a comprehensive service and repair program. If anything should go wrong with your Ford audio system, return to your dealer for service. There is a nationwide network of qualified Ford authorized repair centers to assist you.

Driving Your Continental

Your vehicle has an automatic overdrive transaxle. You may be familiar with the term "transmission." We use *transaxle* because it is a more accurate term for vehicles that have front-wheel drive.

Driving with an Automatic Overdrive Transaxle

Your automatic overdrive transaxle provides fully automatic operation in either **D** (Overdrive) or **D** (Drive). Driving with the shift selector in **D** (Overdrive) gives the best fuel economy for normal driving conditions. For manual control, start in 1 (First) and then shift manually.

Your vehicle is equipped with an Electronic Powertrain Control Module that limits engine and/or vehicle speeds with a cut-out mode to promote durability.

Putting Your Vehicle in Gear

Your vehicle's gearshift can be on the column or on the console.

! WARNING

Hold the brake pedal down while you move the gearshift lever from position to position. If you do not hold the brake pedal down, your vehicle may move unexpectedly and injure someone.

To operate:

1. Start the engine.
2. Depress and hold the brake pedal.
3. Depress the thumb button (console-mounted gearshift only).
4. Move the gearshift lever out of P (Park).

Your vehicle is equipped with a Brake Shift Interlock safety feature. This feature prevents the gearshift from being moved from the P (Park) position until the brake pedal is depressed. This feature is active when the ignition is in the ON position. If the gearshift lever CANNOT be moved from P (Park) with the brake pedal depressed:

1. Turn the engine off and remove the ignition key.
2. Apply parking brake.
3. Reinsert the ignition key and turn clockwise to the first position (OFF).

4. Depress the brake pedal, depress the thumb button (console-mounted gearshift only), move the gearshift lever to N (Neutral) and start the engine.

If you need to shift out of P (Park) by using the alternate procedure described above, it is possible that a fuse has blown and that your brakelamps may also not be functional. Please refer to the *Servicing Your Continental* chapter for instructions on checking and replacing fuses.

! WARNING

**DO NOT DRIVE YOUR VEHICLE
UNTIL YOU VERIFY THAT THE
BRAKELAMPS ARE WORKING.**

Using a column-mounted gearshift

If your gearshift is on the column, you can use any of the following positions:

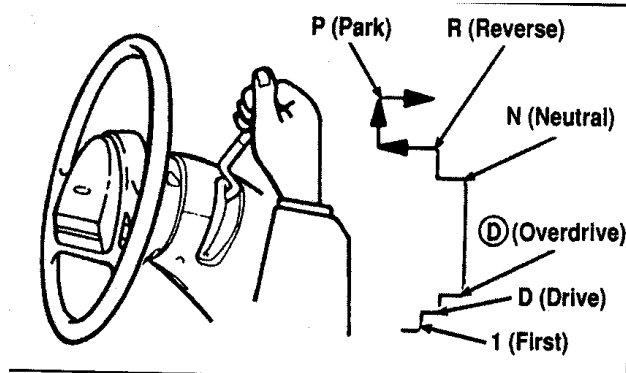

The positions of the column-mounted gearshift

Once you place the gearshift securely into position, gradually release the brake pedal and use the accelerator as necessary.

*Using a console-mounted gearshift
(If equipped)*

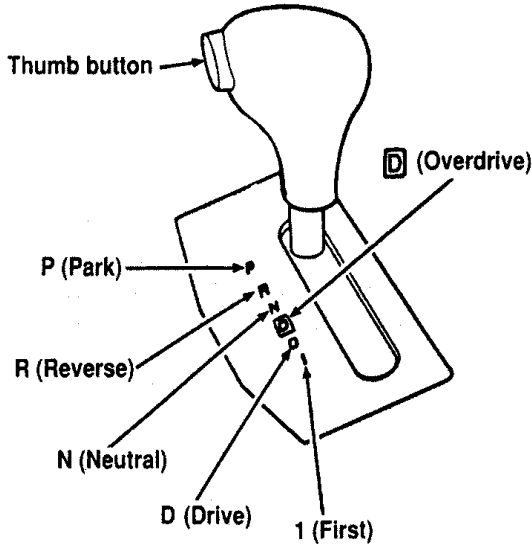

The console-mounted gearshift

The console-mounted gearshift thumb button and brake pedal must be depressed to move the gearshift lever out of P (Park). The thumb button pops out automatically when the gearshift latches into position. Once the gearshift is secure, gradually release the brake pedal and use the accelerator as necessary.

Gear Selection (Column- and Console-Mounted Control)

R (Reverse)

With the gearshift in the R (Reverse) position, the vehicle will move backward. You should always come to a complete stop before shifting into or out of R (Reverse).

N (Neutral)

With the gearshift in the N (Neutral) position, the vehicle can be started and is free to roll. Hold the brake pedal down while in this position.

Driving

When to use **D** (Overdrive)

D (Overdrive) is the usual driving position for an automatic overdrive transaxle. It works the same way **D** (Drive) works, automatically upshifting or downshifting as the vehicle speeds or slows.

However, **D**(Overdrive) also shifts into a fourth gear - an overdrive gear - when your vehicle cruises at a consistent speed for any length of time. This fourth gear will increase your fuel economy when you travel at cruising speeds.

D(Overdrive) may not be appropriate for certain terrain. If the transaxle shifts back and forth between third and fourth gears while you are driving on hilly roads or if your vehicle requires additional power for climbing hills, shift to **D** (Drive).

When to use **D** (Drive)

D (Drive) eliminates the excessive shifting between third and fourth gears that your vehicle sometimes does when you are traveling through hilly terrain in **D** Overdrive. It also gives more engine braking to ml slow your vehicle on downgrades than **D** Overdrive.

When to use **I** (First)

Use **I** (First) when added engine braking is desired when descending steep hills.

The automatic transaxle will shift to the proper gear to ascend any grade without any need to shift to **I** (First).

P (Park)

Always come to a complete stop before you shift into **P** (Park). Make sure that the gearshift is securely latched in **P** (Park). This locks the transaxle and prevents the front wheels from rotating.

⚠ WARNING

Always set the parking brake fully and make sure that the gearshift is securely latched in P (Park). Never leave your vehicle unattended while it is running.

You can tell a column-mounted gearshift is securely latched in P (Park) if the lever is adjacent to the P (Park) and you cannot move it without pulling it toward you and rotating it downward.

You can tell a console-mounted gearshift is securely latched in P (Park) if the lever is adjacent to the P (Park) and you cannot move it without pushing in the thumb button.

The gearshift will lock when you turn the key to the LOCK position. When the gearshift is in any position except P (Park), the ignition key cannot be turned to the LOCK position or removed from the steering column. To remove the key, the gearshift lever must be in P (Park).

Traction Control™ (If equipped)

Your vehicle may be equipped with the optional Traction Control™, system. This system helps prevent wheel spin in order to improve tire traction and is an especially useful feature when you drive in hilly areas or on slippery, icy or snowy roads.

When the Traction Control system is controlling wheelspin, an electric motor sound may be heard from the engine compartment and engine acceleration may seem slower. This is normal.

Traction Control™ works automatically by rapidly applying and releasing the brakes and reducing engine torque to prevent one or both of the front drive wheels from spinning during acceleration.

During the Traction Control™ function, which most often occurs during low speed acceleration on slippery surfaces, a noise may be heard coming from the engine compartment. This is normal and may last for a few seconds during the acceleration of the vehicle.

In general, this system improves your vehicle's stability and acceleration performance when road conditions warrant. Traction Control™ is fully effective at all vehicle speeds.

If the Traction Control™ system is cycled excessively, the brake portion of the system will shut down to prevent the front brakes from overheating. A limited Traction Control™ function using engine torque will still control wheels from spinning. A cooling down period is required to prevent damage to the brakes. This time period varies and depends on brake usage during the cooling down period. Anti-Lock braking is not affected and will function normally during the cool down period.

After the cool down period, the full Traction Control™ function is restored.

Steering Your Vehicle

Your vehicle comes with power steering. Power steering uses energy from the engine to help steer your vehicle.

If the amount of effort needed to steer your vehicle changes, check your steering effort selection in the Message Center. If this is not the problem, have the power steering system checked. If the power steering system breaks down (or if the engine is turned off), you can steer the vehicle manually but it takes more effort.

The steering system in your vehicle is speed sensitive. This means that the steering effort is light for parking and heavier for highway driving. However, if you have to swerve around an object or another vehicle, your steering will have full power assist.

Never hold the steering wheel to the extreme right or left for more than five seconds if the engine is running. This can damage the power steering pump.

Air Suspension Adaptive Ride Control System

Your vehicle has an air suspension system with automatic load leveling and automatic ride control. This system keeps your vehicle at a constant level by adding air or releasing air from the springs. Ride and handling is enhanced by firming shock absorber performance during certain road conditions, steering maneuvers, braking, and accelerations and is returned to the driver selected ride calibration when driver or road surface induced motion changes are completed.

A shutoff switch is located behind an access panel in the left side of the trunk. If this switch is in the OFF position, the air suspension system will remain at a constant state, not adjusting for varying loads or driving conditions.

Normal vehicle operation does not require any action by the driver.

For a more complete listing of the various driving and steering options available, see *Road Calibrated Suspension* in the *Features* chapter.

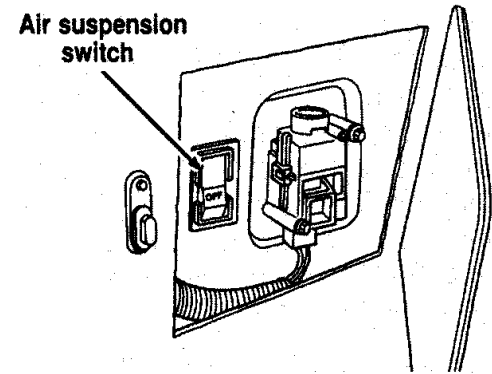

The air suspension switch

Brakes

Applying the Brakes

Your vehicle has anti-lock disc brakes on all four wheels. They adjust automatically as the brake pads wear down.

When you press down hard on the brake pedal, the wheels will not lock and slide. The Anti-lock Brake System (ABS) automatically starts releasing and reapplying the front brakes independently and the rear brakes together whenever your wheels start to lock. When this happens, you will feel the brake pedal pulsate. This is an indication that the ABS system is working correctly and is normal.

Each time you turn the ignition key to the ON position, the anti-lock brake system will function through one test cycle. When this happens, the ANTI-LOCK light will come on for up to five seconds and a clunk may be felt in the pedal. If the light stays on longer than five seconds, shut off the

engine and restart. If it remains on, it means the anti-lock brake system is disabled and should be serviced immediately to restore the benefits of the anti-lock feature. Normal braking is not affected unless the brake warning light is also lit.

The Anti-lock Brake System has self-check capabilities. As described above, the system turns on the ANTI-LOCK light each time you start your engine. After the engine is started and the ANTI-LOCK light turns off, the system performs another test the first time the vehicle reaches 14 m.p.h. (22 km/h). The system turns on the ABS pump motor for approximately 1/2 second. At this time, a mechanical noise may be heard. This is a normal part of the self-check feature. If a malfunction is found during this check the ANTI-LOCK light will come on.

Do not drive with your foot resting on the brake pedal; you will wear out the linings and increase your vehicle's stopping distance. Brake rotor damage may also eventually occur.

NOTE: If you are driving down a long or steep hill, shift to a lower gear and do not apply your brakes continuously. If you apply your brakes continuously, they may overheat and become less effective.

Occasional brake squeal during light to moderate stops does not affect the function of the brake system and is normal. However, if the squeal becomes louder or more frequent, have your brakes inspected by your dealer or a qualified service technician.

Ford Motor Company has not found any detrimental effects of popular mobile radio transmitting equipment installed on vehicles with the anti-lock brake system, if the equipment is installed according to the manufacturer's instructions. However, if mobile radio transmitting

equipment is installed in your vehicle and, if either the anti-lock brake system cycles or the ANTI-LOCK light comes on at any time other than right after you turn the key to the ON position or during a sudden stop, have your mobile radio dealer inspect the installation.

Parking Brake

The parking brake should be used whenever you park your vehicle.

The parking brake is suspended just below the lower left corner of the instrument panel.

To set the parking brake while parking your vehicle, apply the brake pedal with your right foot and hold it while you push the parking brake down firmly and fully with your left foot.

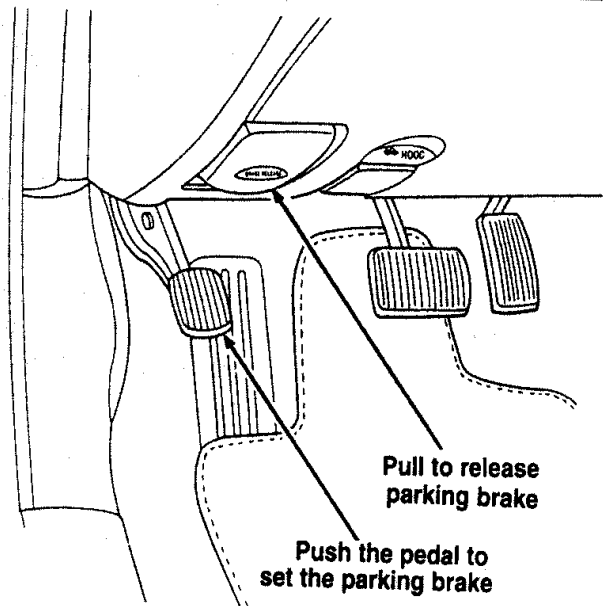

The Parking brake

/! WARNING

Always set the Parking brake fully and make sure that the gearshift is securely latched in P (Park).

/! WARNING

If the parking brake is fully released, but the Brake System light-remains on, have the brakes checked immediately. They may not be working properly.

/! WARNING

To prevent personal injury, do not release the parking brake while outside the vehicle.

You have an automatic release for the parking brake. The parking brake should automatically unlock when you move the gearshift to any forward gear while the engine is running. However, the automatic release does not work when the gearshift is in reverse, neutral or park.

To manually release the parking brake, pull the BRAKE RELEASE handle located on the lower left corner of the instrument panel. The Brake Warning Light will illuminate if the parking brake is not fully released when the engine is running.

The parking brake is not designed to stop a moving vehicle, but you can use the parking brake to stop your vehicle in an emergency if the normal brakes fail. However, since the parking brake applies only the rear brakes, the stopping distance will increase greatly and the handling of your vehicle will be adversely affected.

Always check the Brake Warning light each time you start your engine. Driving with the parking brake on will cause the brakes to wear out quickly and will reduce the fuel economy.

Driving Under Special Conditions

Tips for Safe Driving

As with any new vehicle, yours may drive and handle differently from your previous vehicle. Use care until you become accustomed to its various features and driving characteristics.

Operate your vehicle within reasonable limits. Sudden acceleration, deceleration, turning, or combinations of these maneuvers can cause a vehicle to behave differently than anticipated.

Driving in Bad Weather

Slippery roads

On some slippery road surfaces, front-wheel drive may provide better acceleration than rear-wheel drive. However, this does not mean that your vehicle can stop any faster or any better than a vehicle with rear-wheel drive. Exercise the same caution while driving on slippery roads with your front-wheel drive vehicle as you would with a rear-wheel drive vehicle.

- Do not quickly move the steering wheel unless necessary.
- Drive slower than you normally would.
- Give your vehicle more distance to stop.

! WARNING

To avoid skidding and losing control on slippery roads, do not downshift into First (1) when you are moving faster than 20 mph (32 km/h).

! WARNING

If your vehicle has speed control, do not use it on slippery roads. You could lose control of your vehicle and could injure someone.

If your vehicle gets stuck (for example, in mud or snow), you may try to "rock" it out of the spot. Shift, in a steady rhythm, between forward and reverse gears. While in each gear, press lightly on the accelerator and release.

 WARNING

Do not spin the wheels at over 35 mph (55 km/h). The tires may fail and injure a passenger or bystander.

By moving the vehicle backward and forward, you may gain enough momentum to move out of the spot. Do not rock the vehicle for more than a few minutes. This may overheat the engine, damage the transaxle, or damage the tires. If you are still stuck after a minute or two of rocking, call for a tow truck.

High water

Do not drive through flooded areas unless you are sure that the water is below the bottom of the wheel rims.

If you must drive through high water, drive slowly. You may have limited traction or wet brakes, so allow extra stopping distance because your vehicle will not stop as quickly as usual.

After you drive through the standing water, apply your brakes gently several times as your vehicle moves slowly. This helps to dry the brakes.

Driving With a Heavy Load

There are limits to the amount of weight your vehicle can carry or tow. The total weight of your vehicle, plus the weight of the passengers and cargo, should never be more than the Gross Vehicle Weight Rating (GVWR). Also, the weight that your vehicle carries over the front axle and rear axle should never be more than the Gross Axle Weight Rating (GAWR) for the respective axle.

You can find your vehicle's GVWR and GAWR on the Safety Compliance Certification Label on the left front door lock facing or on the door latch post pillar.

The weight limits of your vehicle's tires affect the GVWR or GAWR limitations. Usage of replacement tires with higher weight limit than originals does not increase GVWR or GAWR. Usage of lower capacity replacement tires may lower GVWR and GAWR limitations.

/! WARNING

If the GVWR or the GAWR specified on the Safety Compliance Certification Label is exceeded, your vehicle may be damaged or you may lose control and injure someone.

Limiting Your Vehicle's Load

The load that you add to your vehicle must not exceed the maximum load stated on the Safety Compliance Certification Decal attached to the left front door pillar.

To figure the weight of your vehicle's load, add the weights of.

- the driver and passengers
- luggage and any other items that you put in your vehicle
- the tongue load of the loaded trailer
- the Weight of any equipment that has been added to your vehicle since it was delivered to your dealer

If you do not know the actual weights of these items, use the following procedure to figure the weight of a load:

1. Weigh your vehicle without the driver, passengers and luggage. You might take your vehicle to a shipping company or an inspection station for trucks.
2. Then weigh your vehicle with the driver passengers and luggage.

3. Subtract the first reading from the second to figure the total weight of the load.

After determining this load, you must also make sure that the total weight of your vehicle, plus the load it carries, is less than its GVWR. Also, make sure that the weight your vehicle carries over each axle is less than the GAWR for the respective axle.

If your vehicle exceeds the GVWR, remove cargo from your vehicle accordingly. If your vehicle exceeds the GAWR for either axle, shift the load or remove cargo accordingly.

⚠ WARNING

Improper distribution of your vehicle's load or carrying weight in excess of the amount shown on the tire decal can cause rapid tire wear or loss of vehicle control.

Trailer Towing

Your vehicle is capable of towing a trailer of up to a maximum of 2,000 lbs. (907 kg) gross trailer weight with a maximum tongue load of 200 lbs. (91 kg).

Because towing a trailer puts extra strain on your vehicle, you must follow certain precautions for your safety and the good of your vehicle:

- Stay within the load limits for towing your vehicle. (See *Trailer towing specifications* in this chapter.)
- Carefully and thoroughly prepare your vehicle for towing, making sure to use the right equipment and to attach it properly. (See *Preparing to Tow* in this chapter.)
- Use extra caution when driving your vehicle while you tow. (See *Driving while you tow* in this chapter.)

- Service your vehicle more frequently if you tow a trailer. (See *Servicing your vehicle if you tow* in this chapter.)

Ten to 15% of the loaded trailer's weight should be on the tongue. However, the tongue load should never exceed 10% of the maximum weight that your vehicle can safely tow.

New vehicles should be driven 2,000 miles (3,200 km) before towing a trailer.

/! WARNING

Towing trailers beyond the maximum recommended gross trailer weight exceeds the limit of the vehicle and could result in engine damage, transaxle damage, structural damage, loss of control, and personal injury.

/! WARNING

Do not tow a trailer when the temporary spare tire is being used.

See the following chart for the amount of weight your vehicle can tow.

Towing Class	Light-duty
Maximum gross trailer weight	1,000/2,000 lbs. (454/907 kg)*
Maximum tongue load	100/200 lbs. (45/91 kg)
Engine	4.OL
Hitch design	Load carrying type
Traffer-tow package option	Not required

Vehicle speed should not exceed 45 mph (72 km/h) when towing on grades. Limit maximum gross trailer weight to 1,000 lbs. (454 kg) and maximum tongue load to 100 lbs. (45 kg): (1) when you are towing a trailer on steep hills or on moderate hills for a long distance (five miles (8 kms) or more) (2) on very hot days (when the temperature is 100°F (38°C) or more).

You should also limit your trailer's load when you tow in high altitudes.

Preparing to Tow

For your safety and for the good of your vehicle, use the right equipment for the type of trailer you tow. Also, make sure that all towing equipment is properly attached to your vehicle. If you are not certain that you are using the right equipment in the proper manner, see your Ford or Lincoln-Mercury dealer.

Do not use hitches that clamp onto your vehicle's bumper. The bumper is not designed to bear the load.

Always check the pressure in all your vehicle's tires when preparing to tow (see inflation recommendation on the tire label).

Connecting the safety chains

Always attach the trailer's safety chains to your vehicle. They help protect your trailer if the hitch breaks.

To connect the trailer's safety chains:

1. Cross the chains under the trailer tongue and attach them to your vehicle's frame or hook retainers. Never attach the safety chains to your vehicle's bumper. The bumper is not designed to bear the weight of a trailer.
2. Make sure that you leave enough slack in the chains to allow you to turn corners.

If you use a rental trailer, follow the instructions that the rental agency gives you.

Connecting the trailer's brakes

Electric brakes and manual, automatic, or surge-type hydraulic brakes are safe if you install them properly and adjust them according to the manufacturer's instructions. Be sure that your trailer's brakes meet local and federal regulations.

Separate trailer brakes of adequate size should be used for trailers weighing over 1,000 lbs. (454 kg) loaded weight.

***!* WARNING**

Do not connect a trailer's hydraulic brake system directly to your vehicle's brake system. Your vehicle may not have enough braking power and your chances of having a collision greatly increase.

Connecting the trailer's lights

Do not connect a trailer's fighting system wiring directly to your vehicle's fighting system wiring. To get the proper equipment for hooking up your trailer's lights, see your local trailer dealer and your Ford dealer. Be sure to follow their instructions carefully.

If you do not install trailer lights correctly, you may cause damage to the vehicle's fighting system.

Driving While You Tow

Be especially careful when driving while you tow a trailer. Never drive faster than 45 mph (70 km/h) when you tow in hilly country on hot days. Also, anticipate stops so that you can brake gradually.

Towing a trailer increases the load on the engine and transaxle, particularly in hilly country and with heavier trailers. Under these conditions you may experience an excessive amount of shifting between Overdrive and Third gears. Moving the shift selector to D (Overdrive Lockout) will keep this from happening and will provide better engine braking. When driving in less hilly country or with a lighter trailer load, you may move the gearshift selector lever to **D** (Overdrive) without experiencing excessive shifting.

When driving down steep hills, you should put the gearshift selector lever in the I (First) position to shift the transaxle into second gear. This will provide additional engine braking. The automatic transaxle will automatically downshift to the proper gear for driving up a grade.

If you use the speed control while you are towing on very long, steep grades, the speed control may shut off.

Servicing your vehicle if you tow

If you tow a trailer for a long distance, your vehicle will need to be serviced more frequently than usual. See the *Maintenance Schedule and Record* booklet.

Roadside Emergencies

Jump-Starting Your Vehicle

Your vehicle's battery may die if you leave the lights on or any electrical equipment on after you turn the engine off. If this happens, you may be able to jump-start from a booster battery to start your vehicle.

/! WARNING

The gases around the battery can explode if exposed to flames, sparks, or lit cigarettes. An explosion could result in injury or vehicle damage.

/! WARNING

To protect yourself when charging a battery, always shield your face and eyes. Make sure that you can breathe fresh air.

/! WARNING

Applying too much pressure on the ends when lifting a battery could cause acid to spill. Lift the battery with a carrier or with your hands on the opposite comers.

/! WARNING

Batteries contain sulfuric acid which burns skin, eyes, and clothing.

If the acid touches someone's skin, eyes, or clothing, immediately flush the area with water for at least 15 minutes. If someone swallows the acid, have him or her drink lots of milk or water first, then Milk of Magnesia, a beaten egg, or vegetable oil. Call a doctor immediately.

To avoid damaging your vehicle or your battery, and to avoid injury to yourself, follow these directions for preparing your vehicle to jump-start and connecting the jumper cables in the order they are given. If in doubt, call for road service.

Preparing Your Vehicle

1. Your vehicle has a 12-volt starting system, so you need to use a 12-volt jumper system. You will damage your starting motor, ignition system, and other electrical parts if you connect them to a 24-volt power supply (either two 12-volt batteries in series, or a 24-volt generator set).
2. Do not disconnect the battery of the disabled vehicle. You could damage the vehicle's electrical system.
3. Park the booster vehicle close to the hood of the disabled vehicle. **Make sure the vehicles do not touch each other.** Set the parking brake on both vehicles and stay clear of the engine cooling fan and other moving parts.
4. Check all battery terminals and remove any excessive corrosion before you attach the jumper cables.

5. Turn on the heater fan in both vehicles. Press the DEFROST button. Turn off all other switches and gauges.

Connecting the jumper cables

1. Connect one end of the first jumper cable to the positive (+) terminal of the discharged battery. (You can connect either jumper cable to the positive (+) terminal, as long as you use the same cable for both positive terminals.) Most jumper cables have a red cable and a black cable. The red cable is generally used for the positive terminals and the black for the negative ones.
2. Connect the other end of the first cable to the positive (+) terminal of the booster battery.

3. Connect one end of the second cable to the negative (-) terminal of the booster battery NOT to the discharged battery.
4. Connect the other end of the second cable to a good metallic surface on the engine or frame of the disabled vehicle.

! WARNING

Do not connect the end of the second cable to the negative (-) terminal of the battery to be jumped. A spark may cause an explosion of the gases that surround the battery.

Make sure vehicles do not touch
Make connections in numerical
order (disconnect in reverse
order 4, 3, 2, 1)

Alternator
mounting
brace stud

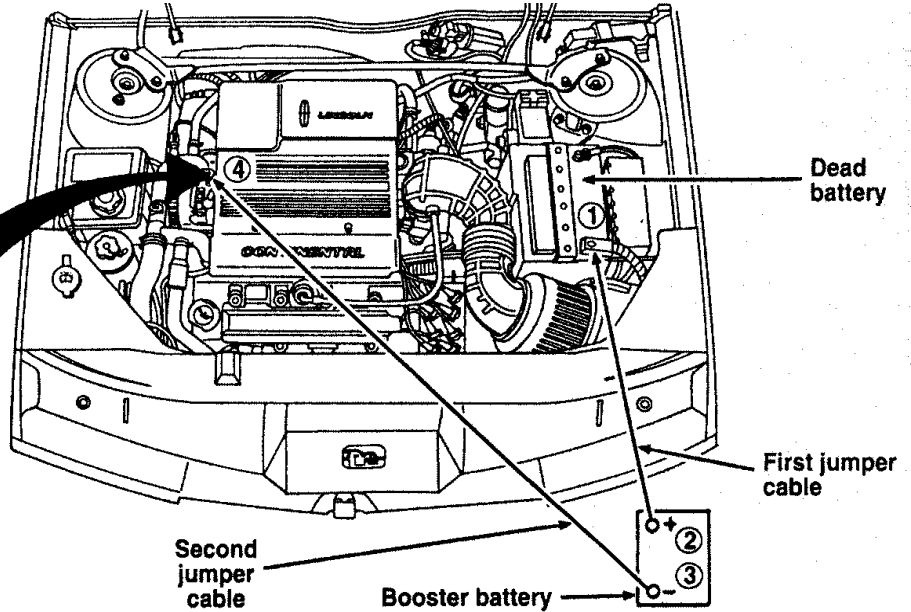
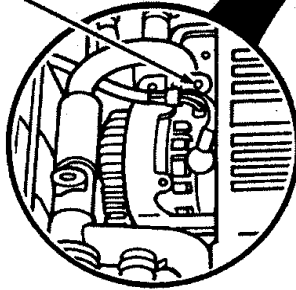

The engine with jumper cables

Jump-Starting

1. Make sure that the jumper cables are not in the way of moving engine parts, then start the booster vehicle. Run the engine at a moderate speed.
2. Let the discharged battery charge for a few minutes and then start the disabled vehicle. It may take a couple of tries before the vehicle starts. If the vehicle does not start after several attempts, there may be a different problem.
3. When both vehicles are running, let them idle for a few minutes to charge the discharged battery.

Removing jumper cables

1. **Always remove the jumper cables in the reverse order.** Remove the negative (-) end of the jumper cable from the metallic surface on the engine or frame of the disabled vehicle.

2. Remove the negative (-) cable from the booster battery.
3. Remove the positive (+) cable from the booster battery.
4. Remove the other end of the positive (+) cable from the discharged battery.

After the vehicle is started, let it idle for a while to let the engine "relearn" its idle conditions. Drive it around for a while with all electrical accessories turned off to let the battery recharge. **You may need to use a battery charger to fully recharge the battery.**

If you need to replace your battery, see *Battery in the Servicing Your Vehicle* chapter.

Changing a Tire

if you get a flat tire while you are driving, do not apply the brake heavily. Instead, gradually decrease the speed. Hold the steering wheel firmly and slowly move to a safe place on the side of the road. Park on a level spot, turn off the ignition, set the parking brake, and turn on the hazard flashers.

The Temporary Spare Tire

You may have a high pressure temporary spare tire. This spare tire is smaller than a regular tire and is designed for emergency use only. Use it only when you get a flat tire and replace it as soon as you can. This spare tire is marked with the words "TEMPORARY USE ONLY" so that you can easily identify it.

/! WARNING

If you use the temporary spare tire continuously or do not follow these precautions, the tire could fail, causing you to lose control of the vehicle, possibly injuring yourself or others.

When you drive with the temporary spare tire, DO NOT:

- exceed 50 mph (80 km/h) under any circumstances.
- load your vehicle so that it is heavier than the maximum vehicle load rating listed on the tire decal.
- tow a trailer.
- try to repair the temporary spare tire or remove it from its wheel.
- use the wheel for any other type of vehicle.

❑ drive through an automatic car wash with this tire. Because the temporary spare tire is smaller than a conventional tire, it reduces the ground clearance. Your vehicle may get caught in the rails and it could be damaged.

Spare Tire Location

The spare tire is stored under the carpet on the floor of the trunk.

You will find additional instructions for the spare tire on the warning label located on the wheel and the jacking instructions located on the spare tire cover.

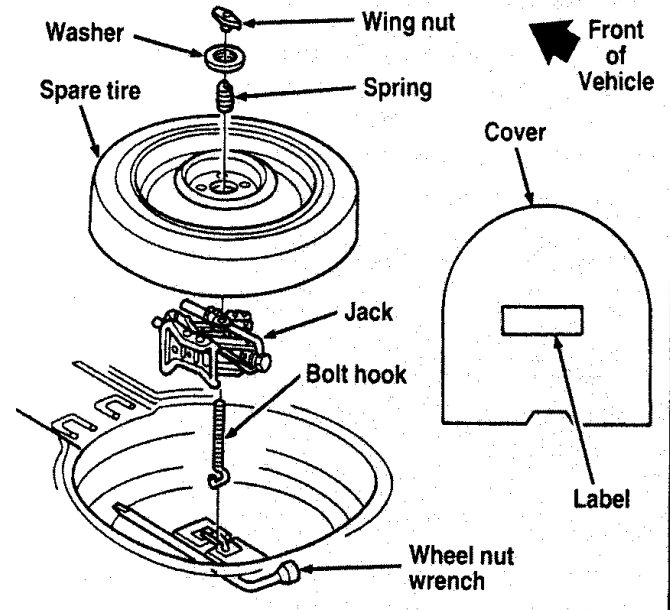

The spare tire location

To remove the spare tire:

1. Remove the spare tire cover.
2. Unscrew the wing-nut holding down the spare tire.
3. Lift out the spare tire and jack kit.

Preparing to Change the Tire

1. Make sure that your vehicle will not move or roll. Put the gearshift in P (Park). Set the parking brake and block the wheel that is diagonally opposite the tire that you are changing.

/! WARNING

If the vehicle slips off the jack, you or someone else could be seriously injured.

Turn off the air suspension switch prior to jacking.

/! WARNING

On vehicles equipped with Air Suspension, turn OFF the Air Suspension switch prior to jacking, hoisting or towing your vehicle.

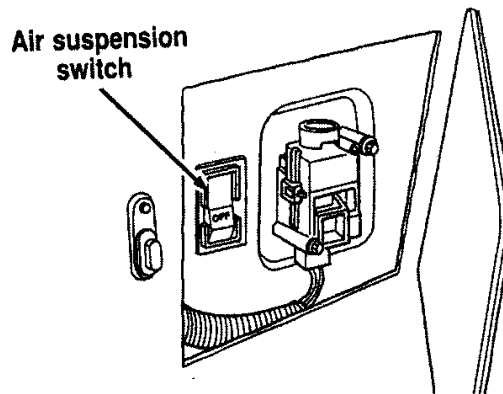

The air suspension switch - located in the trunk

2. Get out the spare tire and jack.

/! WARNING

To avoid injury, never run the engine with one wheel off the ground, such as when changing a tire.

3. Remove the center ornament from the aluminum wheel with the tapered end of the wheel nut wrench which came with your vehicle. Insert and twist the handle, then pry against the wheel.
4. Loosen each wheel lug nut one-half turn counterclockwise, but do not remove them until the tire is raised off the ground. You should pull up on the handle rather than push to develop maximum force to loosen wheel lug nuts. See *Anti-Theft Wheel Lug Nuts* later in this chapter for information on removing anti-theft lug nuts.

Removing and Replacing the Tire

- I - Place the scissors-type jack under the side of the vehicle and adjust the jack height with the jack handle. The jack should fit in the notch in the vertical rocker panel flange which is nearest to the wheel to be changed.

/! WARNING

To lessen the risk of personal injury, do not put any part of your body under the vehicle while changing a tire. Do not start the engine when your vehicle is on the jack. The jack is only meant for changing the tire.

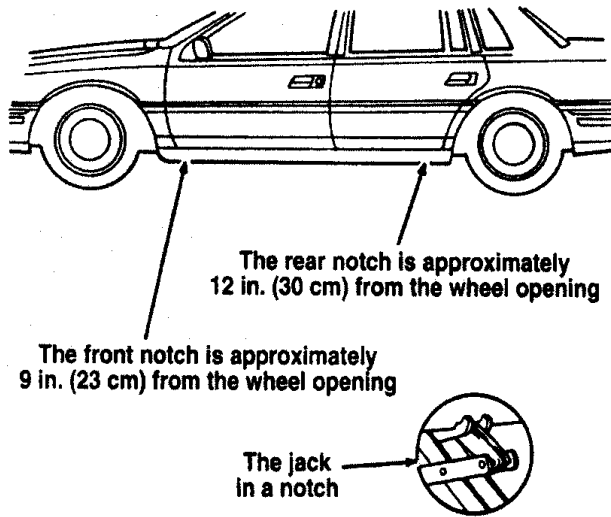

2. Turn the jack handle clockwise until the wheel clears the ground. Remove the wheel lug nuts.
3. Replace the flat tire with the spare tire, making sure that the air valve stem is facing outward.
4. Reinstall the lug nuts, tightening until the wheel is snug against the hub. The beveled edges on the lug nuts face inward. Do not fully tighten the lug nuts until you lower the vehicle. If you do, you could force the vehicle off the jack.
5. Lower the vehicle by turning the jack handle counterclockwise.
6. Remove the jack and fully tighten the lug nuts in the order shown in the following illustration. As soon as possible, have your dealer or a qualified service technician check the lug nuts for proper torque specifications.

The notches for the jack

**Tighten Lug Nuts
in Order Shown**

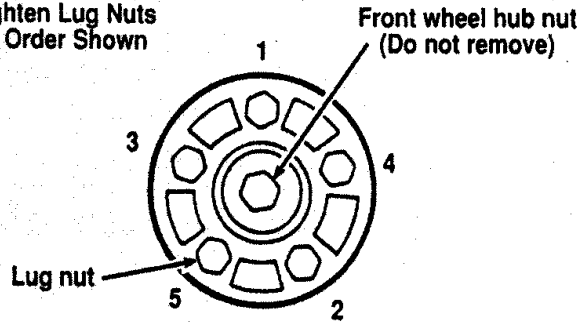

The lug nuts on the wheel

7. Place any ornaments in the trunk.
8. Put the tire, jack, and wrench away. Make sure the jack is securely fastened so it does not rattle when You drive.
9. Unblock the wheels.
10. Turn on the air suspension switch.

After replacing a flat tire with the temporary spare tire, the flat tire can be secured in the trunk tub by placing the "J" hook through a lug nut hole in the wheel with the tire and wheel lying at an angle.

Anti-Theft Wheel Lug Nuts (If equipped)

If your vehicle has this option, one of the lug nuts on each wheel locks and must be unlocked with a special key. The key and registration card are attached to the lug wrench and stored with the spare tire. If you lose the key, send the registration card to the manufacturer (not the dealer) to get a replacement key.

NOTE: If entire lug wrench/lug nut key assembly is lost, see Your nearest Ford Or Lincoln-Mercury dealer who has access to a master set of keys.

**DO NOT USE A POWER IMPACT WRENCH
ON THE LUG NUT KEY**

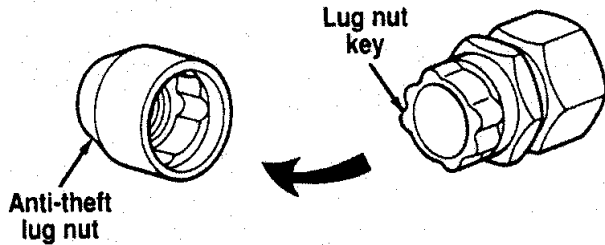

The anti-theft lug nut and key

Removing the anti-theft lug nut

Insert the key over the locking lug nut. Make sure that you hold the key square to the lug nut. If you hold the key on an angle, you may damage the key and the lug nut.

Place the lug nut wrench over the lug nut key and apply pressure on the key with the wrench. Turn the wrench in a counterclockwise direction to remove the lug nut.

Replacing the anti-theft lug nut

Insert the key over the locking lug nut. Place the lug nut wrench over the lug nut key and, while applying pressure on the key, install the lug nut.

If the Engine Cranks But Does Not Start or Does Not Start After a Collision

The Fuel Pump Shut-off Switch

If the engine cranks but does not start or if you have had a collision, the fuel pump shut-off switch may have been triggered. The shut-off switch is a device that stops the fuel pump when your vehicle has been involved in a substantial jolt.

For information on how to check and reset the fuel pump shut-off switch, see *Fuel pump shut-off switch* in the Index.

Towing Your Vehicle

If you need to have your vehicle towed, contact a professional towing service or, if you are a member, your roadside assistance center. Typical towing options include wheel lift towing or flat bed towing.

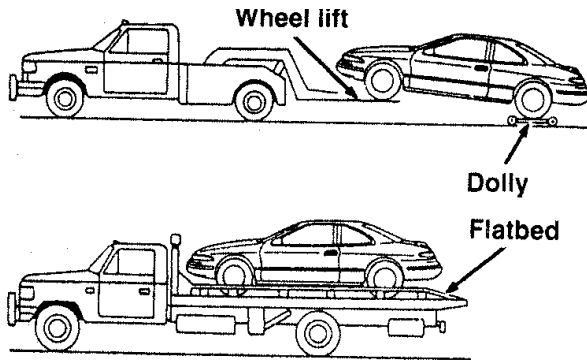

Front towing

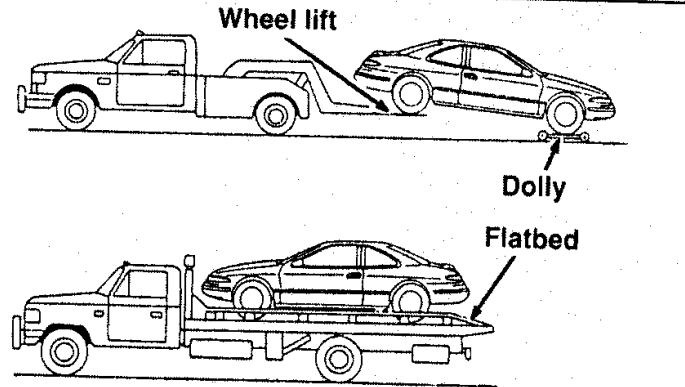

Rear towing

When calling for a tow truck, tell the operator what kind of vehicle you have. A towing manual is available from Ford Motor Company for 0 authorized tow truck operators. Have your tow truck driver refer to this manual for the proper hook-up and towing procedures for your vehicle.

Lincoln RESCU System

(If equipped)

The Lincoln RESCU buttons, located in the overhead console, should be used in the event that you require roadside assistance (out of gas, need a tow, etc.) or emergency assistance (involved in an accident, report a crime or fire, require medical attention, etc.).

See Lincoln RESCU System in the Features chapter for more information.

Customer Assistance

If You Have a Service Problem

Ford Motor Company has authorized Ford and Lincoln-Mercury dealerships that can service your vehicle for you. This chapter tells you how to get service or maintenance for your vehicle.

Service/Maintenance Concerns (U.S. or Canada)

Ford recommends taking your vehicle to your selling dealer who wants to ensure your continued satisfaction. You may, however, take your vehicle to any authorized Ford or Lincoln-Mercury dealer. In most cases, your dealer will be able to resolve your concern.

If you are not satisfied with the service you received from your dealership's service department, talk to the service manager at the dealership, or if you still are not satisfied, talk to the owner or general manager of the dealership. In most cases, you will have your concern resolved at this level.

If you are away from home when your vehicle needs to be serviced, or if you need more help than the dealer gave you, contact the Ford Customer Assistance Center to find an authorized dealership that may be able to help you.

**Ford Motor Company
Lincoln Customer Assistance Center
300 Renaissance Center
P.O. Box 43360
Detroit, MI 48243
1-800.521-4140
TDD for the hearing impaired: 1-800-232-5952**

If you have any questions or concerns that the dealership cannot answer, contact the Customer Assistance Center.

If you still have a service or product complaint, you may wish to contact the Dispute Settlement Board (U.S. only) or the Lincoln Centre (in Canada),

The Dispute Settlement Board (U.S. Only)

The Dispute Settlement Board is a voluntary, independent dispute-settlement program available free to owners or lessees of qualifying Ford Motor Company vehicles.

The Dispute Settlement Board may not be available in all states. Ford Motor Company reserves the right to change eligibility limitations, modify procedures and/or to discontinue this process at any time without notice and without incurring obligations.

What Kind of Cases Does the Board Review?

The Board reviews all product performance and service complaints on Ford, Mercury and Lincoln Cars and Ford and Mercury Light Trucks under warranty that have not been resolved by a dealer or Ford Motor Company.

The Board does not review issues involving:

- A non-Ford product
 - A non-Ford dealership
 - A vehicle sales transaction
 - A request for reimbursement of consequential expenses unless incidental to a service or product complaint being reviewed
- Items not covered by your warranty
 - Alleged liability claims
 - Property damage where such damage is significant when compared to the economic loss alleged under the warranty dispute
 - Cases currently in litigation
 - Vehicles not used primarily for personal, family, or household purposes

NOTE: Complaints involving vehicles on which applicable express written new vehicle warranties have expired at receipt of your application are **not** eligible. Eligibility may differ according to state law. For example, see the unique brochure for California purchasers/lessees.

How Does the Board Work?

The Board has four members:

- three consumer representatives
- a Ford or Lincoln-Mercury dealer

Consumer candidates for Board membership are recruited and trained by an independent consulting firm. Dealers are chosen because of their business leadership qualities.

If the involved vehicle is within 36 months and 36,000 miles of the date of delivery (warranty start date), you have a right to make an oral presentation before the Board by indicating your choice on the application. Also, oral presentations may be requested by the Board. A decision is made by the Board by simple majority vote.

Board members review all the materials related to each complaint and, based on the available information, arrive at a fair and impartial decision. Decisions are based on the written statements and any oral presentations made by each of the involved parties.

Because the Board usually meets only once a month, some cases will take longer than 30 days to be reviewed. The Board will make every effort to resolve each case within 40 days after it receives the customer application form.

After your case has been reviewed, the Board will mail you its decision in writing. It will also provide you with a form to indicate your acceptance or rejection of an award decision. The decisions of the Board are binding on the dealer and Ford, but customers may have other options available to them under state or federal law.

The decisions of the Board, however, may be introduced into evidence by any party in subsequent legal proceedings that may be initiated.

How Do You Contact the Board?

Write to the Board at the following address to request a brochure/application. You will be sent a brochure and a one-page customer application form. The form should be completed and mailed to the same address.

Dispute Settlement Board
P.O. Box 5120
Southfield, MI 48086-5120

What is the Review Process?

Your application will be reviewed and if it is determined to be eligible, you will receive an acknowledgment indicating the file number assigned to your application and the local Board address. At the same time, your dealer and Ford Motor Company representative are asked to submit statements.

To review your case properly, the Board needs the following information:

- legible copies of all documents and maintenance or repair orders that relate to the case
- the year, make, model, and vehicle identification number
- the date you bought your vehicle

- the date of repair and the mileage at the time of repair
- the current mileage
- the name of the dealer who sold you the vehicle or who serviced your vehicle
- a brief description of your unresolved complaint
- a brief summary of actions that were taken with the dealer and Ford Motor Company
- the names (if known) of all people you contacted at the dealership
- a description of the action you want done to resolve your concern.

Should your application NOT qualify for review, an explanation will be mailed to you.

Reporting Safety Defects (U.S. Only)

If you believe that your vehicle has a defect which could cause a crash or could cause injury or death, you should immediately inform the National Highway Traffic Safety Administration (NHTSA) in addition to notifying Ford Motor Company.

If NHTSA receives similar complaints, it may open an investigation, and if it finds that a safety defect exists in a group of vehicles, it may order a recall and remedy campaign. However, NHTSA cannot become involved in individual problems between you, your dealer, or Ford Motor Company.

To contact NHTSA, you may either call the Auto Safety Hotline toll-free at 1-800-424-9393 (or 366-0123 in the Washington, D.C. area) or write to: NHTSA, U.S. Department of Transportation, 400 Seventh Street, Washington D.C. 20590. You can also obtain other information about motor vehicle safety from the Hotline.

Ford of Canada Customer Assistance

If you live in Canada and have any questions or concerns that the dealership cannot answer, contact the Lincoln Centre.

**The Lincoln Centre
Ford Motor Company of Canada, Limited
P.O. Box 1580, Station B
Mississauga, Ontario L4Y 4G3
1-800-387-9333**

Please have the following information available when contacting the Lincoln Centre:

your telephone number (both business and home)

- the name of the dealer and the city where the dealership is located
- the year and make of your vehicle
- the date purchased
- the current mileage on your vehicle
- your Vehicle Identification Number (VIN) listed on your owner card and/or your vehicle ownership license

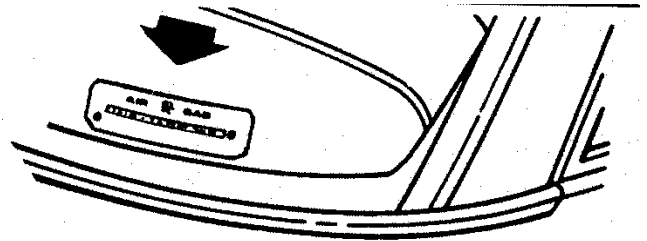

Vehicle Identification Number (VIN/Serial Number)

Canadian Motor Vehicle Arbitration Plan (CAMVAP)

If a specific item of concern arises, where a solution cannot be reached between a vehicle owner, Ford of Canada, and/or one of its dealers (that all parties can agree upon), the owner may wish to use the services offered by the Canadian Motor Vehicle Arbitration Plan (CAMVAP).

CAMVAP uses the services of Provincial Administrators to assist consumers in scheduling and preparing for their arbitration hearings. However, before you can proceed with CAMVAP you must follow your manufacturer's dispute resolution process as outlined under "Service/Maintenance Concerns (U.S. or Canada)" earlier in this chapter.

Consumers wishing to obtain further information about the program can obtain an information booklet from your dealer or contact the Provincial Administrator, Canadian Motor Vehicle Arbitration Plan, at the address or telephone number shown below.

O & P Services

595 Bay Street - Suite 300

Toronto, Ontario

M5G 2C2

Telephone 1 (800) 207-0685

Getting Help Outside the U.S. and Canada

Before you export your vehicle to a foreign country, contact the appropriate foreign embassy or consulate to make sure local regulations do not prevent you from registering your vehicle. Officials at the embassy can also help you decide whether you should import your vehicle to that country.

Officials at the embassy or consulate can tell you where to get unleaded fuel. If you cannot get unleaded fuel or can get only fuel with an anti-knock index that is lower than your vehicle needs, contact a district or owner relations office before you leave the U.S. or Canada.

Use of leaded fuel in your vehicle without a proper conversion may damage the effectiveness of your emissions control system and may cause engine knocking or serious engine damage. Ford Motor Company is not responsible for any damage that is caused by use of improper fuel.

You may also have difficulty importing your vehicle back into the U.S. if you use leaded fuel.

If your vehicle must be serviced while you are traveling or living in Central or South America, the Caribbean, or the Middle East, contact the nearest Ford dealership. If the dealership cannot help you, write to:

**Ford Motor Company
Export Operations
1555 Fairlane Business
Park #3
Allen Park, MI 48101
U.S.A.
Phone: 313-317-4282
Fax: 313-390-0804**

If you are in other foreign countries, contact the nearest Ford dealership. If the dealership cannot help you, they can direct you to the appropriate Ford affiliate office.

If you buy your vehicle in North America and then relocate outside of the U.S. or Canada, register your Vehicle Identification Number and new address with Ford Motor Company Export Operations.

Accessories

Ford Accessories for Your Vehicle

A wide selection of accessories is available through your local authorized dealer. These fine accessories have been engineered specifically to fulfill your automotive needs. They are custom designed to complement the style and aerodynamic appearance of your Ford-built vehicle. In addition, each accessory is made from high quality materials and meets or exceeds Ford's rigid engineering and safety specifications. That is why Ford brand accessories are warranted for up to 3 years or 36,000 miles (60,000 km), whichever comes first. See your dealer for complete warranty information and accessory availability.

Ford has many fine products available from your dealer to clean your vehicle and protect its finishes. For best results, use the following, or products of equivalent quality:

Ford Custom Clear Coat Polish

Ford Custom Silicone Gloss Polish

Ford Custom Vinyl Protectant

Ford Deluxe Leather and Vinyl Cleaner

Ford Extra Strength Spot and Stain Remover

Ford Extra Strength Tar and Road Oil Remover

Ford Extra Strength Upholstery Cleaner

Ford Extra Strength Whitewall Tire Cleaner

Ford Multi-Purpose Cleaner

Ford Premium Car Wash Concentrate

Ford Triple Clean

Ford Ultra-Clear Spray Glass Cleaner

Travel

Heavy-duty battery

Comfort and convenience

Engine block heater

Cargo net

Protection and appearance

Carpeted floor mats

Cleaners, waxes and polishes

Styled wheel protector locks

Super Seal undercoating (in U.S. only)

Touch-up paints

Vinyl protectant

Wheel splash guards (flat)

Vehicle security system

NOTE: When adding accessories, equipment, passengers, and luggage to your vehicle, do not exceed the total weight capacity of the vehicle or of the front or rear axle (GVWR, GAWR as shown on the Safety Compliance Certification Label). Consult your dealer for specific weight information.

NOTE: The Federal Communications Commission (FCC) or in Canada the Canadian Radio Telecommunications Commission (CRTC) regulates the use of mobile communications systems - such as two-way radios, telephones, and theft alarms that are equipped with radio transmitters. Any such equipment installed in your vehicle should comply with FCC or in Canada the CRTC regulation and should be installed only by a qualified technician.

NOTE: Mobile communications systems may harm the operation of your vehicle, particularly if they are not properly designed for automotive use or are not properly installed. For example, when operated, such systems may cause the engine to stumble or stall. In addition, such systems may themselves be damaged or their operation affected by operating your vehicle. (Citizens band CB transceivers, garage door openers, and other transmitters whose power output is 5 watts or less will not ordinarily affect your vehicle's operation.)

NOTE: Because we have no control over the installation, design, or manufacture of such systems, Ford cannot assume responsibility for any adverse effects or damage that may result if you use this equipment.

1996 Continental Owner Manual Order Form

PUBLICATION FORM NO.	DESCRIPTION
FCS-12169-96	1996 Continental Service Manual
FCS-12106-96	1996 Powertrain Control/Emission Diagnosis
FCS-12139-96	1996 Car Service Spec. (FWD/RWD)
FCS-12172-96	1996 Continental Electrical & Vacuum Troubleshooting Manual
93-VID-OM	Ford and the American Dream (50) minutes of Historic/Nostalgic Videotape

- NOTE: For publications prior to year shown above, write for availability to the address shown below. - Please allow ample time for postal service delivery.

U.S. RESIDENTS

Make checks payable to: HELM, INCORPORATED

MAIL ORDER TO:

HELM, INCORPORATED

P.O. Box 07150

Detroit, Michigan 48207

OR ORDER TOLL FREE:

1-800-782-4356

Monday - Friday 8:00 A.M. - 6:00 PM. EST

For Credit Card Holder Orders Only

CANADIAN RESIDENTS

Make cheques payable to: Ford Motor Company of Canada,
Ltd.

MAIL ORDER TO:

Ford Motor Company of Canada, Ltd.

Service Publications

R.O. Box 1580, Station B

Mississauga, Ontario, Canada L4Y 4C3

OR ORDER TOLL FREE:

1-800-387-4966

Monday - Friday 8:30 A.M. - 6:00 PM. EST

For Credit Card Holder Orders Only

LINCOLN

Registered Key Ring

For that special look of distinction, you have been provided a pull apart Registered Key Ring. This Key Ring carries the prestigious Lincoln Star Logo and is registered on the reverse side to facilitate its return should it ever become lost.

The Key Ring is located inside the Owner Guide Portfolio, complete with instructions. Once you fill out the registration card and mail it to us, we will keep your name, address and registration number on file. Should you lose your key ring, all the finder has to do is drop it in any mail box; we will then forward it to you.

To order an extra Key Ring, simply fill out the order form below, or call our toll free number, 1-800-7350482. Please enclose payment of \$15-00 (available in the United States only) for each Key Ring ordered (checks, money orders and Visa or MasterCard are accepted; please no cash or CODS). Michigan residents add 6% Sales Tax. Make checks Payable to Lincoln Key Ring Headquarters.

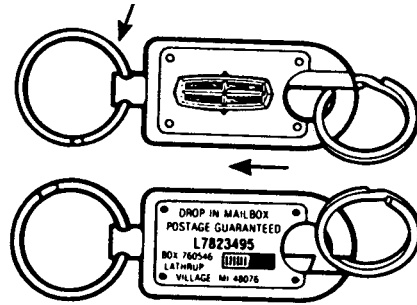

Bottom swivels only,
and not removable.

Slide button down to
remove ring

MAIL TO:

PLEASE SEND ___KEY RINGS

Lincoln Key Ring

at \$15.00 Each \$_____

Headquarters

MI Residents at 6%__

P.O. Box 760546

Total \$_____

Lathrop Village, MI 49076

Enclosed is my Check for

Allow 2-3 Weeks for delivery.

Bill my VISA MASTERCARD

Credit Card Account Number

Expiration Date...

SHIP TO: _____

NAME _____

ADDRESS _____

CITY AND STATE _____

ZIP _____

SIGNATURE _____

Servicing Your Continental

Service Made Easy

Ford has two goals for servicing your vehicle.

1. When we can, we design parts that do not need to be serviced.
2. We want to make servicing your vehicle as easy as possible. To help you:
 - We highlight do-it-yourself items in yellow in the engine compartment so that you can find them easily.
 - When possible, we design - such as the headlamp bulbs-- that can be replaced without tools.
 - We give you a Maintenance Schedule that makes tracking routine service for your vehicle easy. The maintenance schedule is located in the *Maintenance Schedule and Record* booklet.

This chapter tells you about the basic parts that you need to check and service regularly.

If your vehicle needs professional servicing, your dealership can provide the parts and service required. Check your *Warranty Information Booklet* to find out which parts and services are covered. Also see the *Customer Assistance* chapter of this Owner Guide.

Ford Motor Company recommends that the Owner Maintenance Checks listed in the *Maintenance Schedule and Record* booklet be performed for the proper operation of your vehicle. In addition to the conditions listed in the *Owner Maintenance Checklist*, be alert for any unusual noise, vibration, or other indication that your vehicle may need service. If you do notice something unusual, see that your vehicle is serviced promptly.

Use only recommended fuels, lubricants, fluids, and service parts conforming to Ford specifications. Motorcraft parts are designed and built to provide the best performance in your vehicle. Using these parts for replacement is your assurance that Ford-built quality stays in your vehicle.

NOTE: Always dispose of used automotive fluids in a responsible manner. Follow your community's standards for disposing of these types of fluids. Call your local recycling center to find out about recycling automotive fluids.

Accident Damage

Should your vehicle suffer accident damage requiring new sheet metal or plastic replacement parts, be sure your repair shop uses only genuine Ford replacement parts.

While imitation body parts may appear similar to genuine Ford parts on the surface, differences in

quality become obvious when both are subjected to standard Ford quality tests.

Ford tests indicate that you should be concerned with the quality of the fit and finish, corrosion resistance and structural integrity of these imitation replacement parts, and how their use will affect your warranty.

How Can You Protect Yourself?.

Before any repair work begins, tell your adjuster that you want your vehicle repaired using *only* genuine Ford body parts. If the adjuster refuses, contact your insurance agent for help. If your agent and your insurance company refuse to repair your vehicle with original factory parts, you should contact your state insurance commissioner, the National Highway Traffic Safety Administration or a local consumer protection agency.

In Canada, contact provincial insurance commissioners, Transport Canada or local consumer protection groups.

Precautions When Servicing Your Vehicle

Be especially careful when inspecting or servicing your vehicle. Here are some general precautions for your safety:

- ❑ Do not work on a hot engine. The engine cooling fan may come on unexpectedly. Always turn the engine off and let it cool.

⚠ WARNING

The cooling fan is automatic and may come on at any time. Always disconnect the negative terminal of the battery before working near the fan.

- ❑ If you must work with the engine running, avoid wearing loose clothing or jewelry that could get caught in moving parts. Take appropriate precautions with long hair.

- ❑ Do not work on a vehicle in an enclosed space with the engine running, unless you are sure you have enough ventilation.
- ❑ Never get under a vehicle while it is supported by a jack only. If you must work under a vehicle, use safety stands.
- ❑ Keep all lit cigarettes and other smoking materials away from the battery and all fuel-related parts.

If you disconnect the battery, the engine must “relearn” its idle conditions before your vehicle will drive properly. To find out how the engine does this, see *Battery* in this chapter.

Working with the engine off.

1. Set the parking brake fully and make sure that the gearshift is securely latched in P (Park).
2. Remove the key from the ignition after you turn the engine off.

3. Block the wheels. This will prevent your vehicle from moving unexpectedly.

Working with the engine on:

1. Set the parking brake fully and make sure that the gearshift is securely latched in P (Park).
2. Block the wheels. This will prevent your vehicle from moving unexpectedly.

/!\ WARNING

Do not start your engine with the air cleaner removed and do not remove it while the engine is running.

/!\ WARNING

The cooling fan is automatic and may come on at any time. Always disconnect the negative terminal of the battery before working near the fan.

If the battery is disconnected' the computer must releam its idle control. See *Battery* in the Index.

NOTE: The engine compartment light may be switched on or off at the light assembly. The light assembly is located on the hood on the driver's side. To turn the light on, pull the switch toward you; to turn it off, push it away from you. The switch may remain in the on position at all times, as the light will turn off when the hood is closed.

Opening the Hood

1. Inside the vehicle, pull the hood release handle located under the bottom left corner of the instrument panel.

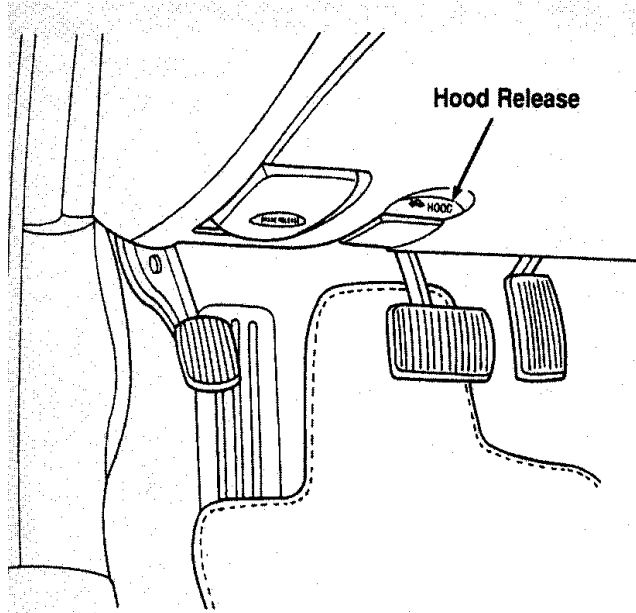

The hood release under the instrument panel

2. Go to the front of the vehicle and release the auxiliary latch that is located under the hood at the center of the vehicle.

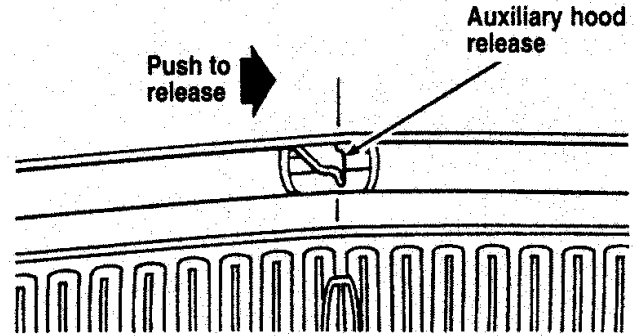

The auxiliary latch under the front edge of the hood

3. Lift the hood until the lift cylinders hold it open.

Whenever you close the hood, latch it securely.

NOTE: Apply lubricant to the hood latch at six-month intervals to maintain smooth and trouble-free operation.

NOTE: Read and understand *Precautions When Servicing Your Vehicle* at the beginning of this chapter before opening the hood.

Engine Compartment

Your vehicle has a 4.6 liter 4V SFI engine. The following page shows a diagram of where to find items that you should regularly service.

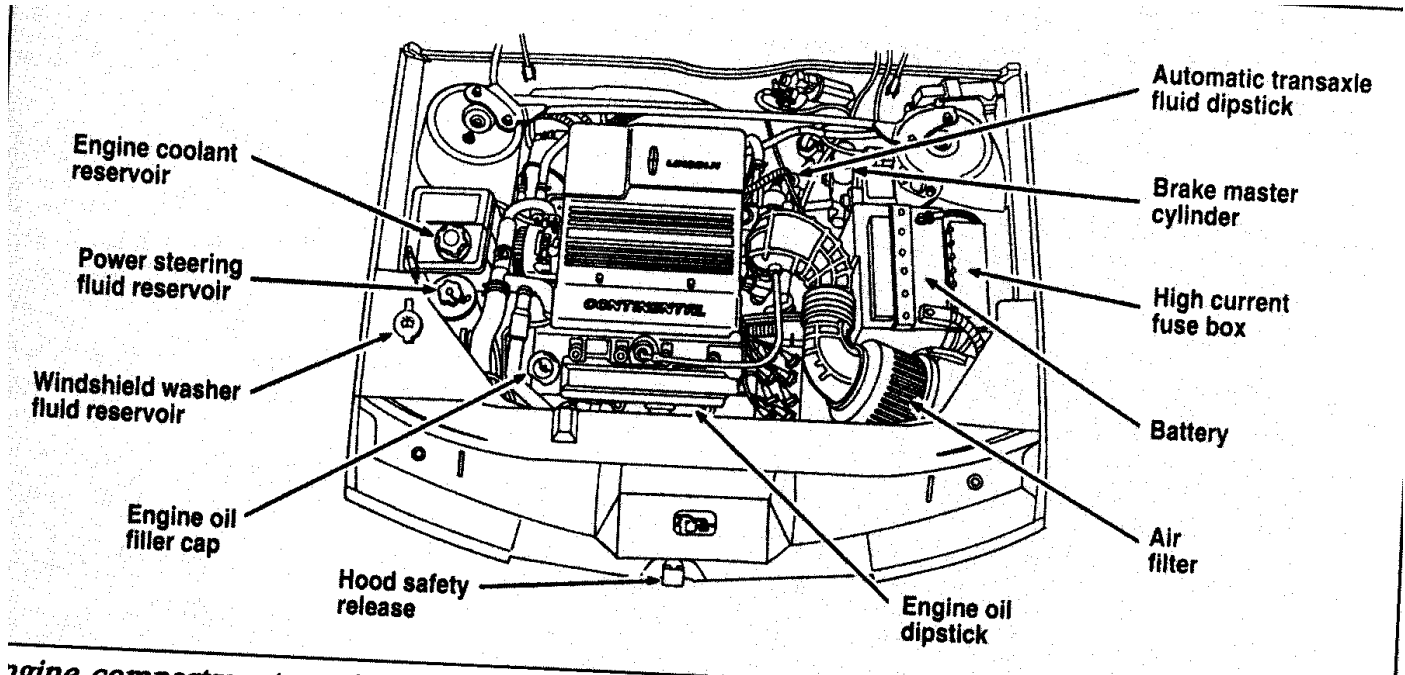

Engine compartment service points

Filling the Fuel Tank

The fuel filler door cannot be opened from outside the vehicle. To unlatch the fuel door, push on the fuel door button located on the driver side door trim.

The fuel door is on the exterior of passenger side, near the back of the vehicle. The words FUEL FILL and an arrow on the instrument cluster remind you that the fuel door is on that side.

Located on driver's door

Manual override
located in trunk
on RH side

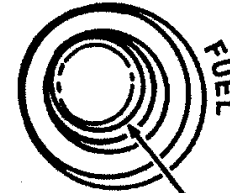

Press button
to open fuel
filler door

The fuel door release button

If the fuel door does not open when you push the release button, open the trunk and find the override release on the right side. The override release is a handle which says FUEL FILLER DOOR RELEASE MANUAL OVERRIDE. Open the fuel door by pulling on the handle.

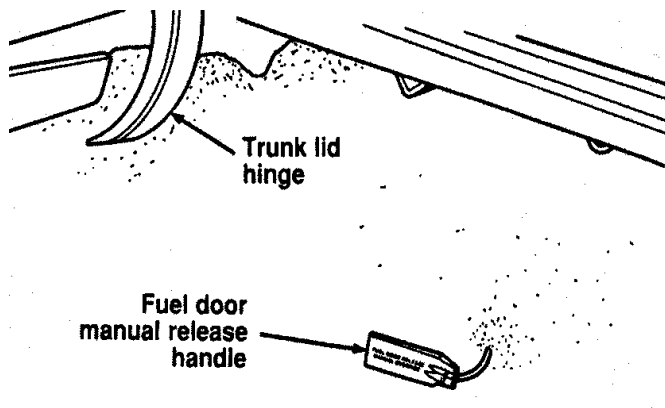

Fuel door release - manual override

1. After opening the fuel filler door, remove the cap carefully and slowly by turning it counterclockwise 1/2 to 3/4 turn. If a hissing sound is heard, wait until it stops, then continue turning until the cap is free.

⚠ WARNING

If the fuel cap is venting vapor or if you hear a hissing sound, wait until it stops before completely removing the cap.

2. Make sure that you pump premium unleaded fuel and put the nozzle all the way inside the fuel filler pipe.

NOTE: If you spill any fuel on the body of your vehicle, clean it off immediately. The fuel may dull or soften the paint if you do not wash it off.

3. Replace the fuel cap completely when you are finished. Turn it clockwise 1/4 turn until it is tight. It will click when it is fully tightened.
4. Push the fuel door closed.

! WARNING

If you do not use the proper fuel cap, the pressure in the fuel tank can damage the fuel system or cause it to work improperly in a collision.

NOTE: If you replace your fuel cap with an aftermarket fuel filler cap, the customer warranty may be void for any damage to the fuel tank and/or fuel system.

Choosing the Right Fuel

Use only PREMIUM UNLEADED FUEL in your vehicle. Using leaded fuel is prohibited by federal law. Your warranty may not apply if your vehicle is damaged because you used the wrong fuel.

Octane recommendations

The 4.6L engine is designed to operate on premium fuel with an octane rating of 91 or higher. Regular fuel with an octane rating of 87

may be used if necessary. For optimum performance, premium fuel is recommended.

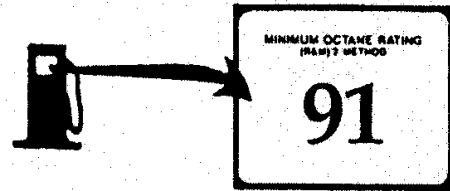

Typical octane rating label

In some parts of the country, "premium" grade fuels are sold with octane ratings of less than 91, especially in high altitude areas. It is recommended that you use only those "premium" fuels with an octane rating of 91 or higher.

Do not be concerned if your vehicle sometimes knocks lightly when you drive up a hill or when you accelerate. However, see your dealer or a qualified service technician if persistent, heavy knocking occurs because this can damage the engine.

If you are experiencing starting, rough idle or hesitation problems when the engine is cold, it may be caused by fuel with low volatility. Try a different brand of fuel. If the condition persists, see your dealer or a qualified service technician.

Gasolines for clean air

Fuels in certain areas of the country are required to contain oxygenates to improve air quality.

Common oxygenates are ethanol or grain alcohol (blended at no more than 10%), methanol or wood alcohol (blended at no more than 5% with cosolvents and additives), and MTBE or methyl tertiary butyl ether (blended at no more than 15%).

Generally, you should not experience difficulties operating your vehicle on fuels containing oxygenates. We encourage you to use these fuels.

Safety Information Relating to Automotive Fuels

! WARNING

Automotive fuels can cause serious injury or death if misused or mishandled.

- Turn vehicle off when refueling.
- Do not smoke when refueling. Fuels are extremely flammable.
- Do not siphon any fuel by mouth.

! WARNING

Gasoline or gasoline blended with methanol can cause blindness and possible death when swallowed. If any fuel is swallowed, call physician or poison control center immediately.

- ❑ Avoid breathing vapors while refueling.
- ❑ If fuel is splashed on the skin, wash with soap and water.
- ❑ If fuel is splashed in the eyes, remove contact lenses (if worn), flush with water for 15 minutes, and seek medical attention.

Gasoline and gasoline blends may contain small amounts of carcinogens, such as benzene. Long-term exposure to unleaded gasoline vapors has caused cancer in laboratory animals.

if you are taking the medication "Antabuse" or other forms of disulfiram for the treatment of alcoholism, vapor or skin contact with a gasoline-methanol blend, may cause the same kind of adverse reaction as drinking an alcoholic beverage. In sensitive individuals, serious personal injury or sickness could result. Consult a physician promptly if you experience an adverse reaction.

Running Out of Fuel

NOTE: Avoid running out of fuel because this situation may have an adverse effect on modern powertrain components.

You may need to crank the engine several times before the fuel system starts to pump fuel from the tank to the engine.

If the engine does not start, check the fuel pump shut-off switch and reset as required. See *Fuel pump shut-off switch* in the Index.

! WARNING

Never pour fuel in the throttle body or attempt to start the engine with the air cleaner removed. Doing so could result in fire and personal injury.

Fuel Economy

Fuel economy is an estimate of the efficiency of your vehicle and can be calculated as Miles Per Gallon (MPG) or liters Per 100 Kilometers (*L/100K*).

Do not calculate fuel economy during your vehicle's break-in period. This would not be an accurate estimate of how much fuel your vehicle will normally use.

To calculate fuel economy:

1. Fill the tank completely and record the initial odometer reading.
2. Every time you buy fuel record the amount (in gallons or liters) purchased.
3. After at least three to five tankfuls, fill the fuel tank and record the final odometer reading.
4. Use these equations to calculate your fuel economy.

English: $\text{MPG} = (\text{total miles})/(\text{gallons used})$.

Metric: $\text{L}/100\text{K} = (\text{liters used}) \times 100/(\text{total kilometers})$

Comparisons With EPA Fuel Economy Estimates

EPA fuel economy figures are obtained from laboratory tests under simulated road conditions and may not reflect the actual conditions you experience or your style of driving. The EPA fuel economy estimate is not a guarantee that you will achieve the fuel economy shown.

The following decrease fuel economy:

- Lack of regular, scheduled maintenance
- Rapid acceleration and excessive speed
- Driving with your foot on the brake
- Sudden stops
- Extended engine idling

- Using speed control in hilly terrain
- Extended use of the A/C, defroster, rear window defroster and other accessories
- Underinflated tires
- Heavy loads
- Aftermarket add-ons such as bike, ski or luggage racks, bug deflectors, etc.

Self-Service Pointers

If you choose to do your own fueling, you should also perform a few simple maintenance routines. This extra effort will save you additional money and contribute to the driving efficiency of your vehicle.

The following procedures require only a tire gauge, a rag, an oil can spout and windshield washer fluid.

- Check the engine oil at every refueling stop
- Clean the windshield, outside mirrors and headlights

- Check windshield washer fluid
- Check tires for excessive wear or worn edges
- Check the tire pressure at least monthly

Engine Oil Recommendations

We recommend using Motorcraft oil or an equivalent oil meeting Ford Specification ESE-M2C153-E and displaying the American Petroleum Institute CERTIFICATION MARK on the front of the container.

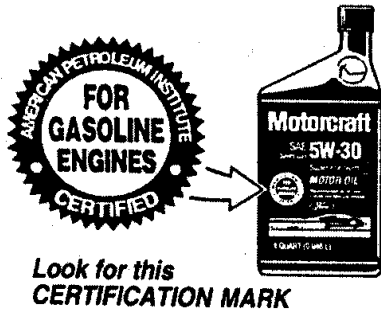

The API Certification Mark

Never use:

- "Non-Detergent" oils
- Oils labeled API SA, SB, SC, SD, SE, SF or SG
- Additional engine oil additives, oil treatments or engine treatments

Engine oils with an **SAE 5W-30** viscosity are **PREFERRED** for your vehicle. They provide the best engine performance, fuel economy and engine protection for all climates down to -15°F (-25°C).

Synthetic engine oils which are **CERTIFIED** and of the preferred viscosity may be used in your engine. The engine oil and oil filter must still be changed according to the maintenance schedule.

Checking and Adding Engine Oil

Since the proper amount of engine oil is important for safe engine operation, check the oil using the dipstick each time you put fuel in your vehicle. Remember the engine must be off, the oil must be warm and the vehicle must be parked on level ground.

Checking the engine oil level:

1. Turn the engine off after it has warmed up and allow a few minutes for the engine oil to drain back into the oil pan.

2. Set the parking brake, making sure the gearshift is securely latched in P (Park).
3. Open the hood. Protect yourself from engine heat.
4. Locate the engine oil dipstick (highlighted in yellow) and carefully pull it out of the engine.
5. Wipe the dipstick clean and put it back into position, making sure it is fully seated.

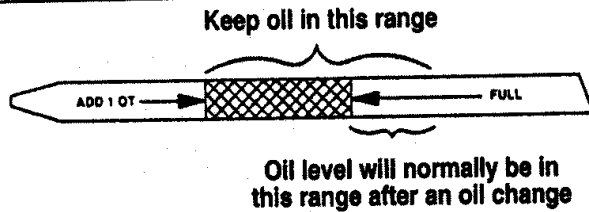

Engine oil dipstick

6. Carefully, pull the dipstick out again. If the oil level is below the "ADD 1 QT" line, add engine oil as necessary. If the oil level is beyond the letter "F" in Full, engine damage or high oil consumption may occur and some oil must be removed from the engine.
7. Put the dipstick back in and make sure it is fully seated.

It may be necessary to add some oil between oil changes. Make sure you use a CERTIFIED engine oil of the preferred viscosity. Your vehicle's warranty coverage may not apply if engine damage is caused by the use of improper engine oil.

Add engine oil through the oil filler cap highlighted in yellow. To add oil, remove the filler cap and use a funnel to pour oil into the opening. Be careful not to overfill the engine. Recheck the oil level after you finish adding oil.

Changing the Engine Oil and the Oil Filter

Refer to the *Maintenance Schedule and Record* booklet for recommended intervals.

⚠ WARNING

Continuous contact with USED motor oil has caused cancer in laboratory mice.

Protect your skin by washing with soap and water.

Engine Coolant

Checking the Engine Coolant

NOTE: Be sure to read and understand *Precautions Men Servicing Your Vehicle* at the beginning of this chapter.

⚠ WARNING

The cooling fan is automatic and may come on at any time. Always disconnect the negative terminal of the battery before working near the fan.

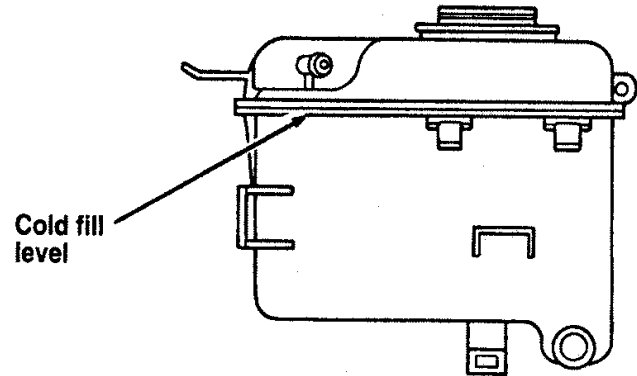

The engine coolant reservoir

Your vehicle's coolant protects your engine from overheating in the summer and from freezing in the winter. Check the level of the coolant at least once a month. Simply look at the engine coolant reservoir located in the engine compartment. To locate the reservoir, see the diagram of your vehicle's engine under *Engine Type*, in this chapter.

Check the engine coolant level in the engine coolant reservoir at least once a month using the following guidelines.

When your vehicle's engine is cool, the coolant level in the engine coolant reservoir should be at the top of the clear portion of the reservoir. If the level is below the cold fill level, coolant may need to be added.

The coolant additives also protect the entire cooling system from internal passageway corrosion and these additives lubricate the water pump. The coolant should be serviced as noted in the *Maintenance Schedule and Record* booklet.

Adding engine coolant

⚠ WARNING

Do not put engine coolant in the container for the windshield washer fluid.

If sprayed to clean the glass, engine coolant or antifreeze could make it difficult to see through the windshield.

⚠ WARNING

Never remove the pressure cap while the engine is running or hot. Follow these steps to avoid personal injury that can be caused by escaping steam or engine coolant.

1. Before you remove the cap, turn the engine off and let it cool. Even when the engine is cool, be careful when you remove the pressure cap.

2. When the engine is cool, wrap a thick cloth around the cap and turn it slowly counter-clockwise to relieve pressure.
3. Step back while the pressure releases.
4. When you are sure that all the pressure has been released, use the cloth to turn and remove cap.
5. Stand away from the reservoir opening. Hot steam may blow out or hot engine coolant may even splash out.

 WARNING

Failure to follow these instructions could result in serious personal injury from hot engine coolant or steam blowout and/or damage to the engine cooling system or engine.

To find out how much engine coolant mixture your vehicle's coolant system can hold, see *Refill capacities for fluids* in the Index.

Add engine coolant only to the coolant reservoir.

If the coolant level is low, add to the reservoir a 50/50 or appropriate mixture of water and the type of engine coolant that Ford specifies. You may add water by itself only in an emergency, but you should replace it with a 50/50 mixture as soon as possible. Check the engine coolant again the next few times you drive your vehicle.

Have your dealer check the engine cooling system for leaks if you have to add more than a quart (liter) of engine coolant more than once a month.

Ford Premium Cooling System Fluid is an optimized formula that will protect all metals and rubber elastomers used in Ford engines for four years or 50,000 miles (80,000 km). It is not necessary and not recommended to use supplemental coolant additives in your vehicle. These additives may harm

your engine cooling system. Follow the recommended service interval for changing your engine coolant.

NOTE: When you change or add engine coolant, it is important to maintain your engine coolant concentration between 40% (-11°F [-24°C]) and 60% (-62°F [-52°C]), depending on your local climate conditions. Below 40% you will lose freeze protection; above 60% your engine may overheat on a warm day.

NOTE: Less than 40% of coolant concentration may cause engine corrosion and overheating. Plain water may be used in an emergency only. Replace it with the specified coolant as quickly as possible.

NOTE: The use of an improper coolant may void your warranty for the engine cooling system. Use only a premium, nationally recognized brand name engine coolant. Do not use alcohol, methanol antifreeze or engine coolant mixed with alcohol or methanol antifreeze. If you do not use the proper

coolant, the aluminum engine on your vehicle will corrode.

Ford Motor Company expressly authorizes the Ford Rotunda engine coolant recycling process and chemicals. Use only Ford Rotunda recycled engine coolant or an equivalent recycled engine coolant that is certified by the supplier to meet Ford specification ESE-M97B44-A.

NOTE: Always dispose of used automotive fluids in a responsible manner. Follow your community's standards for disposing of these types of fluids. Call your local recycling center to find out about recycling automotive fluids.

Use Ford Premium Cooling System Fluid E2FZ-19549-AA (in Canada, Motorcraft CXC-8-B) or an equivalent engine coolant that meets Ford Specification ESE-M97B44-A.

Engine coolant drain and flush

Proper procedures for a complete coolant drain and flush of the cooling system can be found in the *Car Service Manual*. Following these recommended procedures will ensure that the specified coolant level and a 50/50 or appropriate mixture of coolant and water is maintained.

Engine coolant refill procedure

When the entire cooling system is drained and refilled, the following procedure should be used to ensure a complete fill:

NOTE: It is imperative the following procedure be adhered to. Failure to do so could result in damage to your engine.

- Remove coolant reservoir pressure cap.
- Remove the engine coolant outlet tube fill plug on the engine.

- With the engine off and cool, add a 50/50 mixture of recommended cooling system fluid and water to the coolant outlet tube fill neck until the reservoir is full.

NOTE: DO NOT FILL COOLANT SYSTEM THROUGH COOLANT RESERVOIR. COOLANT WILL NOT ENTER ENGINE, WHICH CAN LEAD TO ENGINE DAMAGE.

NOTE: Avoid spilling coolant on the front end accessory drive belt, as this will allow the belt to slip and become noisy.

- Reinstall the pressure cap to the coolant reservoir.
- Continue filling at the engine coolant tube fill neck slowly while allowing air to escape.
- Reinstall the engine coolant tube fill plug when the system is full.

- ❑ Select maximum heater temperature and fan speed settings. Position control to discharge air at A/C vents in instrument panel.
- ❑ Start engine and allow to idle. While engine is idling, feel for hot air at A/C vents.

NOTE: IF AIR DISCHARGE REMAINS COOL AND ENGINE TEMPERATURE GAUGE DOES NOT MOVE, SHUT ENGINE OFF IMMEDIATELY. This is an indication of low coolant level and/or air pockets in coolant system. Allow engine to cool and repeat the previous steps.

- ❑ Allow to idle until normal operating temperature is reached. Hot air should discharge from A/C vents. The engine temperature gauge should maintain a stabilized reading in the middle of the "NORMAL" range and the lower radiator hose should feel hot to the touch.
- ❑ Shut off the engine and allow to cool down.

- ❑ After the engine cools down, recheck the engine coolant level. Fill reservoir to the COLD-FULL level as required.
- ❑ Check for leaks at the draincock, block plug and vent plug.
- ❑ Recheck the engine coolant level, using the recommended procedure, after one or two occasions of vehicle use. Fill to COLD-FULL level as required.

Battery

Your vehicle may have a Motorcraft maintenance-free battery. When the original equipment battery is replaced under warranty it may be replaced by a low-maintenance battery. See *Motorcraft Parts* at the end of this chapter for the proper replacement battery.

The low-maintenance battery has removable vent caps for checking the electrolyte level and adding water. The electrolyte level should be checked at least every 24 months or 24,000 miles (40,000 km) in temperatures up to 90°F (32°C) and more often in temperatures above 90°F (32°C). Keep the electrolyte level in each cell up to the level indicator. Do not overfill.

If the level gets low, refill the battery with distilled water. If necessary, you can add tap water to the battery, provided the water is not hard or does not have a high mineral or alkali content. If the battery needs water quite often, have the charging system checked for a possible malfunction.

Help Us Protect Our Environment

Ford Motor Company strongly recommends that used lead-acid batteries be returned to an authorized recycling facility for disposal.

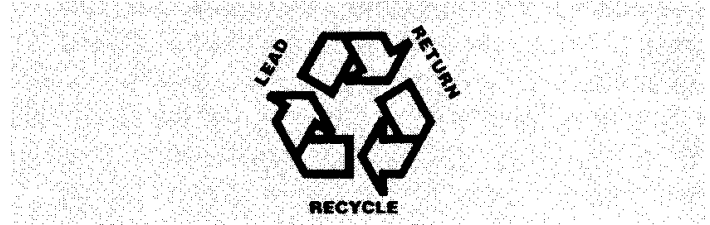

Battery recycling symbol

Because your vehicle's engine is electronically controlled by a computer, some control conditions are maintained by power from the battery. If you ever disconnect the battery or install a new battery, you must allow the computer to "relearn" its idle conditions before your vehicle will drive properly. To let the engine do this, put the gearshift in P (Park), turn off all the accessories, and start the vehicle. Let the engine idle for at least one minute. (Engine must be warm in order to "learn.") Also, allow approximately 10 miles (16 km) of stop and go traffic for your vehicle's engine to completely "relearn" its idle.

If you do not let the engine relearn its idle, the idle quality of your vehicle may be adversely affected until the idle is relearned. Your vehicle will eventually relearn its idle while you drive it, but it takes much longer than if you use the previous procedure.

Windshield Washer Fluid and Wipers

Washer Fluid

Check the level of the windshield washer fluid every time you stop for fuel. The reservoir for washer fluid is located on the passenger's side of the engine compartment. Visual inspection can determine if the washer fluid is adequate. Do not operate the washer when the reservoir is empty.

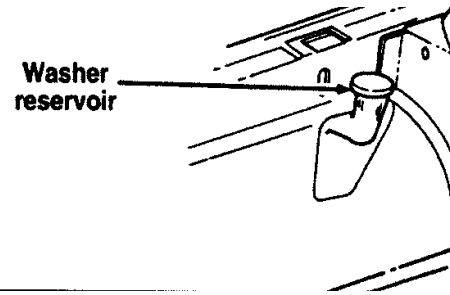

The reservoir for the windshield washer fluid

⚠️WARNING

Do not put windshield washer fluid in the container for the engine coolant.

Use specially formulated windshield washer fluid rather than plain water, because specially formulated washer fluids contain additives that dissolve road grime. For safety reasons, washer fluids containing an appropriate antifreeze such as methanol should be used in freezing weather.

(temperatures below 32°F [0°C]). State or local regulations on Volatile Organic Compounds (VOC's) may restrict use of the most common antifreeze, methanol. Washer fluids containing non-methanol antifreeze agents should be used only if they provide cold weather protection without damaging the vehicle's paint finish, wiper blades, and windshield washer system.

Wiper Blades

Check the windshield wiper blades at least twice a year. Also check them whenever they seem less effective than usual. Substances such as tree sap and some hot wax treatments used by commercial car washes reduce the effectiveness of wiper blades.

If the blades do not wipe properly, clean both the windshield and the wiper blades. Use undiluted windshield washer solution or a mild detergent. Rinse thoroughly with clear water. Do not use fuel, kerosene, paint thinner, or other solvents to clean your wiper blades. These will damage your blades.

To make reaching the wiper blades easy, simply turn the ignition to the ACC position and turn your wipers on. Wait for them to reach a vertical position and turn the ignition to the OFF position. Do not move the wipers manually. Manually moving the wipers across the windshield may damage them.

Wiper blade replacement

If the wiper blades still do not work properly after you clean them, you may need to replace the wiper blade assembly or the blade element. When replacing the wiper blade assembly, blade refill, or wiper arm always use a Motorcraft part or equivalent. To replace the blades, follow the instructions that come with them.

Tires

Look at your tires each time you fill your fuel tank. If one tire looks lower than the others, check the pressure in all of them. Always follow these precautions:

- ❑ Keep your tires inflated to the recommended pressures.
- ❑ Stay within the recommended load limits (see *Load limits* in the Index).
- ❑ Make sure the weight of your load is evenly distributed.

If you do not take these precautions, your tires may fail or go flat.

Ford Motor Company recommends obeying posted speed limits.

⚠ WARNING

Driving too fast for conditions creates the possibility of loss of vehicle control. Driving at very high speeds for extended periods of time may result in damage to vehicle components.

At least once a month, check the pressure in all your vehicle's tires, including the spare. Use an accurate tire pressure gauge. Check the tire pressure when tires are cold, after the vehicle has been parked for at least one hour or has been driven less than 3 miles (5 km). You can find proper cold pressure and load limits of recommended size tires on the Safety Compliance Certification Label.

⚠ WARNING

Improperly inflated tires can affect vehicle handling and can fail suddenly, possibly resulting in loss of vehicle control.

Tire Rotation

Because your vehicle's front and rear tires perform different jobs, they often wear differently. To make sure your tires wear evenly and last longer, rotate them as indicated in the following diagram.

Do not include the spare tire as part of your rotation.

For tire rotation intervals, see the *Maintenance Schedule*. If you notice that the tires wear unevenly, have them checked.

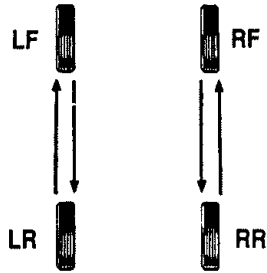

Rotating the tires

Replacing the Tires

Replace any tires that show wear bands. When your tire shows a wear band, it has only 1/16 inch (2 mm) of tread left.

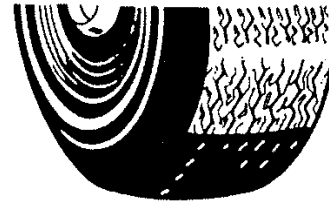

Wear Band

A worn-out tire

Because your vehicle's tires may wear unevenly, you may need to replace them before a wear band appears across the entire tread. Some spots wear more heavily than others.

/! WARNING

When replacing full size tires, never mix radial, bias-belted, or bias-type tires. Use only the tire sizes that are listed on the tire pressure decal. Make sure that all tires are the same size, speed rating, and load-carrying capacity. Use only the tire combinations recommended on the decal. If you do not follow these precautions, your vehicle may not drive properly and safely.

Tires that are larger or smaller than your vehicle's original tires may also affect the accuracy of your speedometer.

Information About Tire Quality Grades

New vehicles are fitted with tires that have their Tire Quality Grade (described below) molded into the tire's sidewall. These Tire Quality Grades are determined by standards that the United States Department of Transportation has set.

Tire Quality Grades apply to new pneumatic tires for use on passenger cars. They do not apply to deep tread, winter-type snow tires, space-saver or temporary use spare tires, tires with nominal rim diameters of 10 to 12 inches or limited production tires as defined in Title 49 Code of Federal Regulations Part 575.104(c)(2).

U.S. Department of Transportation - Tire quality grades: The U.S. Department of Transportation requires Ford to give you the following information about tire grades exactly as the government has written it.

Treadwear

The treadwear grade is a comparative rating based on the wear rate of the tire when tested under controlled conditions on a specified government test course. For example, a tire graded 150 would wear one and one-half (1 1/2) times as well on the government course as a tire graded 100. The relative performance of tires depends upon the actual conditions of their use, however, and may depart significantly from the norm due to variations in driving habits, service practices and differences in road characteristics and climate.

Traction A B C

The traction grades, from highest to lowest, are A, B, and C, and they represent the tire's ability to stop on wet pavement as measured under controlled conditions on specified government test surfaces of asphalt and concrete. A tire marked C may have poor traction performance. Warning: The traction grade assigned to this tire is based on braking

(straightahead) traction tests and does not include cornering (turning) traction.

Temperature A B C

The temperature grades are A (the highest), B, and C, representing the tire's resistance to the generation of heat and its ability to dissipate heat when tested under controlled conditions on a specified indoor laboratory test wheel. Sustained high temperature can cause the material of the tire to degenerate and reduce tire life, and excessive temperature can lead to sudden tire failure. The grade C corresponds to a level of performance which all passenger car tires must meet under the Federal Motor Vehicle Safety Standard No. 109. Grades B and A represent higher levels of performance on the laboratory test wheel than the minimum required by law. Warning: The temperature grade for this tire is established for a tire that is properly inflated and not overloaded. Excessive speed, underinflation, or excessive

loading, either separately or in combination, can cause heat buildup and possible tire failure.

Snow tires

The tires on your vehicle have all-weather treads that provide traction in rain or snow. However, during the winter months in some climates, you may need to use snow tires.

Use of tire chains is not recommended. The use of tire chains could result in damage to your vehicle.

/! WARNING

Snow tires must be the same size and grade as the tires you currently have on your vehicle.

Cleaning the Wheels

Wash the wheels with the same detergent you use to wash your vehicle's body. Do not use acid-based wheel cleaners, steel wool, abrasives, fuel, or strong

detergents. These substances will damage protective coatings. Use tar and road oil remover to remove grease and tar.

NOTE: Before going to a car wash, find out if the brushes are abrasive.

If you have whitewall tires that are difficult to clean with regular detergent, use whitewall tire cleaner. Follow the directions on the container and rinse the tires with plenty of clean water.

Securitires (If equipped)

Securitires are designed to allow you to continue driving your Continental a limited number of miles when one of your vehicle's tires is at low or even zero air pressure.

/! WARNING

Do not use aerosol tire inflator/sealer with Securitires. Doing so may damage the tire's pressure sensor.

See *Securities* in the *Features* chapter for more information.

Automatic Transaxle Fluid

Under normal circumstances, you do not need to check the fluid level of the transaxle, since your vehicle does not use up transaxle fluid. Refer to the *Maintenance Schedule and Record* booklet for replacement intervals. However, if the transaxle is not working properly - for instance, the transaxle may slip or shift slowly, or you may notice some sign of fluid leakage - the fluid level should be checked.

NOTE: If the vehicle has been operated for an extended period at high speeds or in city traffic during hot weather, or pulling a trailer, the vehicle should be turned off for about 30 minutes to allow the fluid to cool before checking.

Checking the Automatic Transaxle Fluid

With the vehicle on a level surface and the brake fully applied, start the engine and move the gear shift selector through all of the gears allowing sufficient time for each position to engage. Securely latch the gear shift selector in the P (Park) position. Fully set the parking brake and leave the engine running.

Wipe off the dipstick cap and pull the dipstick out. Wipe the indicator end clean. Put the dipstick back into the filler tube and make sure it is fully seated. Pull the dipstick out and read the fluid level.

NOTE: Your vehicle should not be driven until some fluid has been added if the fluid level is below the bottom dimple on the dipstick and the outside temperature is above 50°F (10°C). Add only enough fluid to bring the level above the bottom hole.

If the vehicle has not been driven and the fluid level is above the bottom dimple on the dipstick, do not add fluid. Recheck the fluid level after your vehicle has reached normal operating temperature.

Normal operating temperature is reached after driving approximately 20 miles (30 km). The fluid level should be within the crosshatched area on the dipstick.

NOTE: If the vehicle has been operated for an extended period at high speeds, driven in city traffic during hot weather, or has been pulling a trailer, the vehicle should be turned off for about 30 minutes to allow the fluid to cool before checking.

Adding Automatic Transaxle Fluid

Before adding any fluid, be sure that the correct type will be used. Correct type is shown on the dipstick.

Add fluid in 1/2 pint (.25L) increments through the filler tube to bring the level to the correct area on

the dipstick. **DO NOT OVERFILL.** If the level is above the top hole on the dipstick, excess fluid should be removed by a qualified technician.

NOTE: Always dispose of used automotive fluids in a responsible manner. Follow your community's standards for disposing of these types of fluids. Call your local recycling center to find out about recycling automotive fluids.

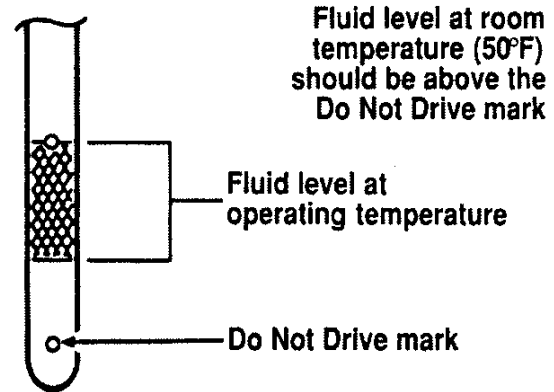

Automatic over transaxle fluid dipstick

Brake Fluid

Under normal circumstances, your vehicle should not use up brake fluid rapidly. However, expect the level of the brake fluid to slowly fall as you put more mileage on your vehicle and the brake lining wears.

You should check the brake fluid at every scheduled engine oil change, but be sure to check it at least once a year. You can do this by looking at the fluid level in the plastic reservoir on the master cylinder. (See *The Engine Type* in this chapter to locate the master cylinder.) The fluid level should be at or near the MAX mark.

⚠ WARNING

Brake fluid is toxic.

If brake fluid contacts eyes, flush eyes with running water for 15 minutes. Get medical attention if

irritation persists. If taken internally, drink water and induce vomiting. Get medical attention immediately.

If the fluid is low, carefully clean and remove the cap from the reservoir. Fill the reservoir to the MAX line with Ford High Performance DOT 3 Brake Fluid C6AZ-19542-AA, C6AZ-19542-BA, or equivalent DOT 3 fluid meeting Ford specification ESA-M6C25-A.

⚠ WARNING

If you use a brake fluid that is not DOT 3, you will cause permanent damage to your brakes.

Do not fill the reservoir above the MAX line.

If you find that the fluid level is excessively low below the seam or ridge on the outside of the plastic reservoir - have the brake system inspected.

⚠ WARNING

Do not let the reservoir for the master cylinder run dry. This may cause the brakes to fail.

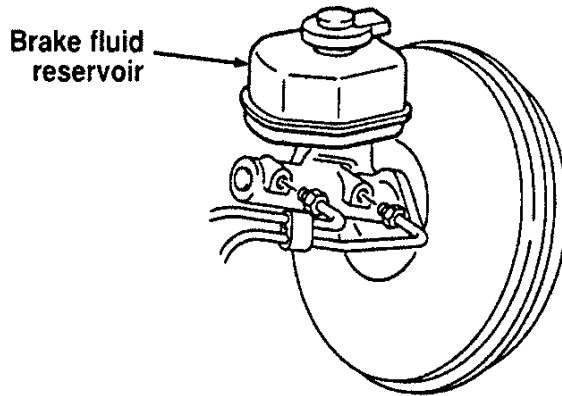

The brake fluid reservoir

Power Steering Fluid

Check the level of the power steering fluid at least twice a year (i.e., every Spring and Fall).

Checking and Adding Power Steering Fluid

1. Start the engine and let it run until the power steering fluid reaches normal operating temperature. The power steering fluid will be at the right temperature when the engine coolant temperature gauge in the instrument cluster is near the center of the NORMAL operating temperature range.
2. While the engine idles, turn the steering wheel back and forth several times. Make sure that the cap assembly is installed at this time.

3. Turn the engine off and check the level on the power steering reservoir.
4. The fluid level is viewed through the sight window on the power steering reservoir. If the power steering fluid is below the middle line, add fluid in small amounts, continuously checking the level. Do not overfill.

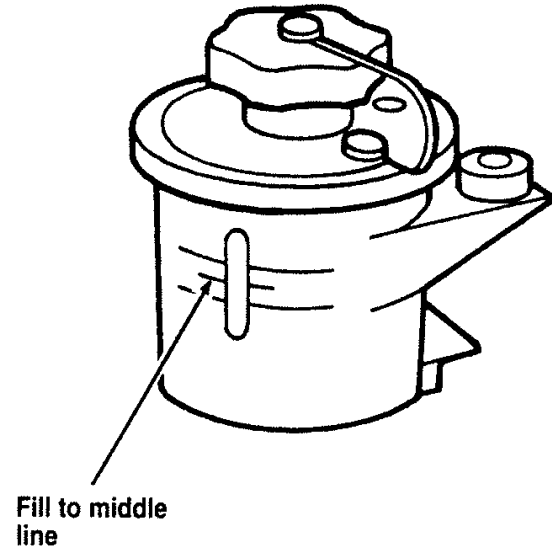

The power steering fluid reservoir

Use only MERCON® ATF power steering fluid.

If the power steering fluid is low, do not drive your vehicle for a long period of time before adding fluid. This can damage the power steering pump.

Fuses

Fuses (conventional and high current) protect your vehicle's electrical system from overloading. If electrical parts in your vehicle are not working, the system may have been overloaded and blown a fuse. Before you replace or repair any electrical parts, check the appropriate fuses (conventional and high current).

The following charts tell you which fuses protect each electrical part of your vehicle. If a fuse blows, **all** the parts of your vehicle that use that circuit will not work.

Once you have determined which fuses to check, follow the procedures under *Checking and replacing fuses* in this chapter.

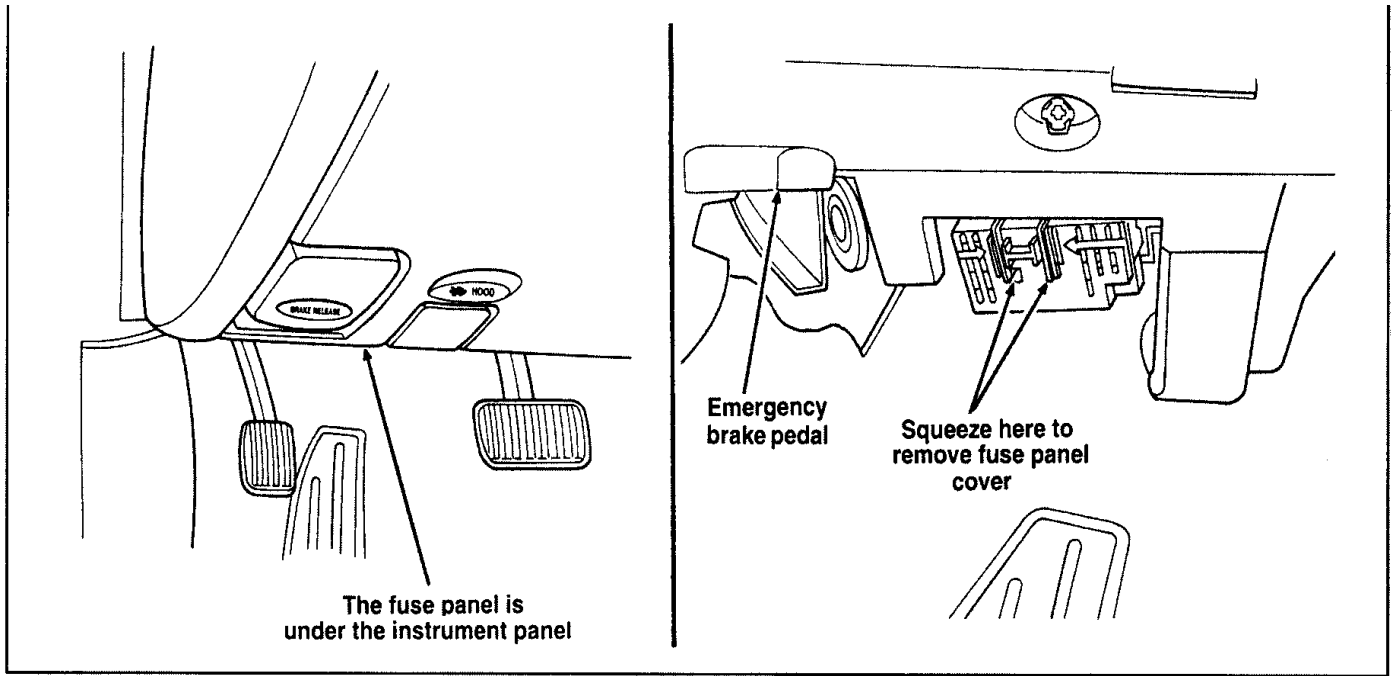

The instrument panel fuse panel location

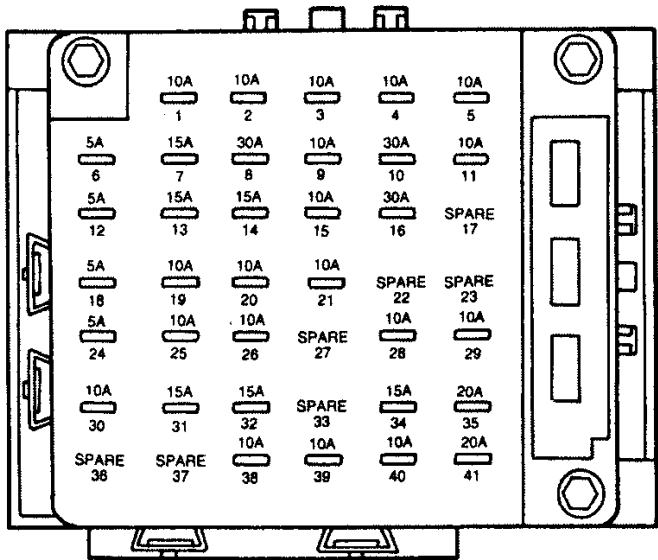

The instrument panel fuse panel

The Instrument Panel Fuses

Fuse Location	Fuse Amp Rating	Description
1	10A	<ul style="list-style-type: none"> ■ And-theft indicator light ■ PWM dimming output for microphone illumination, ashtray illumination (R & L rear door), heated seat switches, heated backlight switch, EATC control panel, message center switches, cigar lighter, console shift illumination, navigation display module, and navigation switches
2	10A	<ul style="list-style-type: none"> ■ Luxury radio ■ Clock (non-navigational) ■ Cellular phone
3	10A	<ul style="list-style-type: none"> ■ Multi-function switch
4	10A	<ul style="list-style-type: none"> ■ Run/Accessory sensor (luxury radio) ■ Cellular phone ■ Run/Accessory sensor (LCM) ■ Window switches backlight RF, LR, RR) * ■ Compass

Fuse Location	Fuse Amp Rating	Description
4 (cont.)	10A	<ul style="list-style-type: none"> • E/C mirror • Stand alone clock • Door lock switches backlight
5	10A	<ul style="list-style-type: none"> • Virtual image cluster • Light sensor (Autolamp) • Traction Assist OFF switch • Airbag diagnostic • Luxury radio FCU • Run/Start sensor (LCM)
6	5A	<ul style="list-style-type: none"> • SCP network
7	15A	<ul style="list-style-type: none"> • Right front turn lamp • Right turn indicator • HI beam switch • Right and left front side marker lamps • Right and left front park lamps • Right and left front tail lamps • Right rear stop/turn lamps
8	30A	<ul style="list-style-type: none"> • Fuel filler • Trunk solenoid • Navigation system power

Fuse Location	Fuse Amp Rating	Description
9	10A	<ul style="list-style-type: none"> Blower motor relay coil EATC control Airbag diagnostic
10	30A	<ul style="list-style-type: none"> Windshield wiper motor Windshield wiper control module (washer pump motor)
11	10A	<ul style="list-style-type: none"> PCM power relay coil Ignition coil
12	5A	<ul style="list-style-type: none"> SCP network
13	15A	<ul style="list-style-type: none"> Stand alone clock illumination Right and left rear side marker lamps License lamps Right and left tail lamps (on decklid) Left rear stop/turn lamps Left turn indicator Left front turn lamp
14	15A	<ul style="list-style-type: none"> Front cigar lighter

Fuse Location	Fuse Amp Rating	Description
15	10A	<ul style="list-style-type: none"> Navigation display Navigation module Heated seat control switches
16	30A	<ul style="list-style-type: none"> power moonroof switch Moonroof motor
17		(Not used)
18	5A	<ul style="list-style-type: none"> SCP network
19	10A	<ul style="list-style-type: none"> LH low beam
20	10A	<ul style="list-style-type: none"> Multi-function switch (Flash to pass and hazard signal to LCM) LH & RH cornering lamps
21	10	<ul style="list-style-type: none"> ABS control module
22		(Not used)
23		(Not used)
24	5A	<ul style="list-style-type: none"> SCP network
25		<ul style="list-style-type: none"> RH low beam
26	10A	<ul style="list-style-type: none"> Instrument cluster power EATC power
27		(Not used)

Fuse Location	Fuse Amp Rating	Description
28	10A	<ul style="list-style-type: none"> • Shift interlock • VDM logic power • Instrument cluster logic power • Rear defrost control
29	10A	<ul style="list-style-type: none"> • Luxury RCU station signal • Navigation module signal
30	10A	<ul style="list-style-type: none"> • Heated mirror right • Heated mirror left
31	15A	<ul style="list-style-type: none"> • Voltage dimming for FCU and stand alone clock • Courtesy lamps in the doors • Rear reading lamps • Map lamps • RH & LH I/P courtesy lamps • Engine compartment lamp • Visor lamps • Storage bin lamp (5 passenger only) • Luggage compartment lamp • Glove box lamp
32	15A	<ul style="list-style-type: none"> • Speed control brake deact switch • Stop lamp switch

Fuse Location	Fuse Amp Rating	Description
33		(Not used)
34	15A	<ul style="list-style-type: none"> • Back-up L & R lamp ext. • DRL module (Canada only) • EATC clutch • Speed control logic • IMRC
35	20A	<ul style="list-style-type: none"> • L & R heated seat module power
36		(Not used)
37		(Not used)
38	10A	<ul style="list-style-type: none"> • OBD 11 scan tool connection
39	10A	<ul style="list-style-type: none"> • DSM logic power • DDM logic power • Door lock switches • Keyless keypad switch • Memory set switch • Driver seat switch • Power mirror switch
40	10A	<ul style="list-style-type: none"> • Blend door actuator • LTPS
41	20A	<ul style="list-style-type: none"> • Door locks (DDM)

High Current Fuses

High current fuses are circuit protectors that are part of the wiring harness for some electrical equipment. These, like fuses, open when the circuit load exceeds their amperage rating. High current fuses may be purchased from your Ford or Lincoln-Mercury dealer.

The high current fuse panel is located in the engine compartment on the left-hand fender apron.

⚠ WARNING

Always disconnect the battery before servicing high current fuses.

Ford recommends that high current fuses be replaced by a qualified technician.

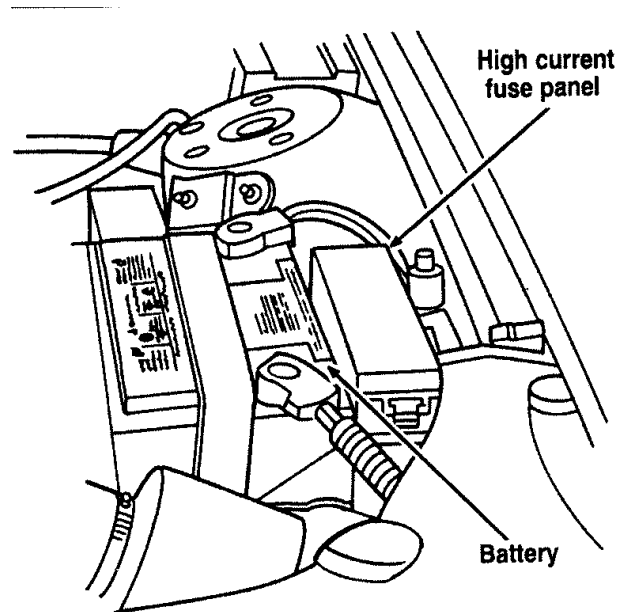

The high current fuse panel location

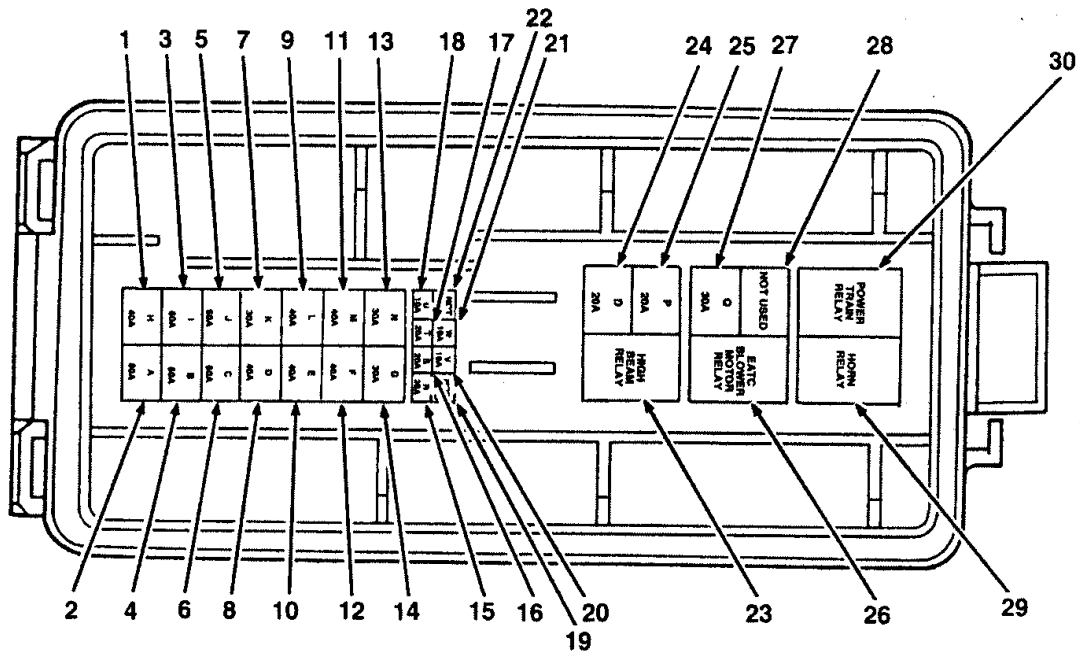

The underside of the high current fuse panel cover

Fuse Location	Maxi-Fuse Amp Rating	Description
1	40A	<ul style="list-style-type: none"> EATC blower motor
2	60A	<ul style="list-style-type: none"> Engine cooling fans
3	60A	<ul style="list-style-type: none"> Air suspension compressor relay
4	60A	<ul style="list-style-type: none"> ABS module EVAC and fill
5	60A	<ul style="list-style-type: none"> Fuse panel to LCM OBD 11
6	60A	<ul style="list-style-type: none"> Fuse panel to LCM CD player
7	30A	<ul style="list-style-type: none"> VDM
8	40A	<ul style="list-style-type: none"> Heated mirrors Heated backlight
9	40A	<ul style="list-style-type: none"> DDM LH power windows Door locks
10	40A	<ul style="list-style-type: none"> RH power windows
11	40A	<ul style="list-style-type: none"> Ignition switch to fuse panel
12	40A	<ul style="list-style-type: none"> Ignition switch to fuse panel

Fuse Location	Maxi-Fuse Amp Rating	Description
13	30A	<ul style="list-style-type: none"> DSM Heated seats Driver 4-way power lumbar seats
14	30A	<ul style="list-style-type: none"> Passenger power seat Passenger 4-way power
15	30A	<ul style="list-style-type: none"> Luxury radio Sub woofer amplifier CD player
16	20A	<ul style="list-style-type: none"> HI beam
17	20A	<ul style="list-style-type: none"> Horn
18	10A	<ul style="list-style-type: none"> Air bags
19		Not used
20	10A	<ul style="list-style-type: none"> PCM KAPWR
21	10A	<ul style="list-style-type: none"> Alternator sensor Alternator field supply

Fuse Location	Maxi-Fuse Amp Rating	Description
22		Not used
23	Relay	<ul style="list-style-type: none"> • HI beam headlamps relay
24	20A	<ul style="list-style-type: none"> • Fuel pump
25	20A	<ul style="list-style-type: none"> • Thermaxtor pump
26	Relay	<ul style="list-style-type: none"> • EATC blower motor relay
27	30A	<ul style="list-style-type: none"> • PCM • STC
28		Not used
29	Relay	<ul style="list-style-type: none"> • Horns relay
30	Relay	<ul style="list-style-type: none"> • Powertrain control module relay

Checking and Replacing Fuses

If you need to check a fuse, follow these steps:

1. Find the fuse panel underneath the instrument panel to the left of the steering column. Squeeze together the two areas indicated by the arrows and pull down to remove the cover.
2. Find the fuse you want to check (fuses are numbered on the fuse panel) and remove it with the fuse pulling tool that is provided.
3. Check the fuse to see if it is blown. Look through the clear side of the fuse to see if the metal wire inside is separated. If it is, the fuse should be replaced.

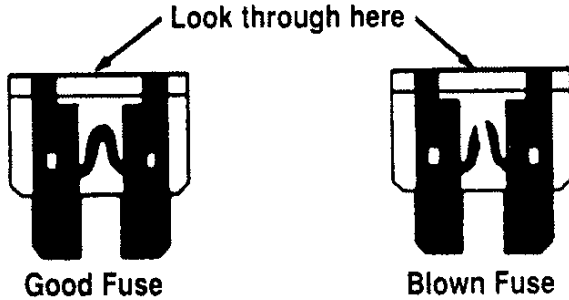

The side view of a Blade type fuse

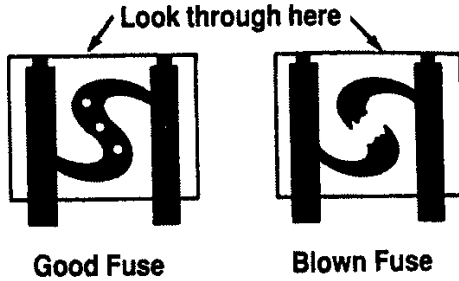

The side view of a high current fuse

4. Replace the fuse with one that has the right amperage rating. (See the following charts.)

Instrument Panel Fuse Color	Amperage
Tan	5A
Red	10A
Blue	15A
Yellow	20A
Green	30A

High Current Fuse Color	Amperage
Yellow	20A
Green	30A
Orange	40A
Blue	60A

! WARNING

Always replace a fuse with one that has the specified amperage rating. Using a fuse with a higher amperage rating can cause severe wire damage and could start a fire.

5. Align the edge of the cover with the edge of the fuse panel and push the cover up until it latches.

Even after you replace a fuse, it will continue to blow if you do not find what caused the overload. If the fuse continues to blow, have your electrical system checked.

Lights and Bulb Replacement

It is a good idea to check the operation of the following lights frequently:

- headlamps

- high-mount brakelamp
- tail lamps
- brakelamps
- hazard flasher
- turn signals
- side markers
- license plate lamp

The alignment of your headlamps should be checked if:

- oncoming motorists frequently signal you to turn off your vehicle's high beams when you do not have the high beams on
- the headlamps do not seem to give you enough light to see clearly at night

- the headlamp beams are pointed substantially away from a position slightly down and to the right

Headlamp Bulb

The headlamps on your vehicle use replaceable bulbs. When the lamp burns out, simply replace the bulb, rather than the whole lamp.

⚠ WARNING

Handle a halogen headlamp bulb carefully and keep out of children's reach. Grasp the bulb only by its plastic base and do not touch the glass. The oil from your hand could cause the bulb to break the next time the headlamps are operated.

Removing the headlamp bulb

Do not remove the burned-out bulb unless you can immediately replace it with a new one. If a bulb is removed for an extended period of time, contaminants may enter the headlamp housing and affect its performance.

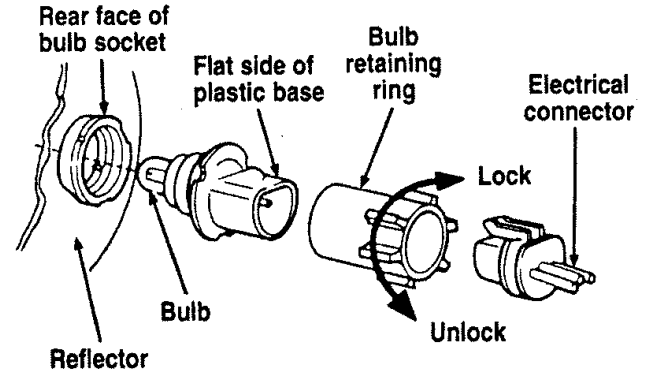

Parts of a headlamp

1. Make sure that the headlamp switch is in the OFF position.
2. Lift the hood and remove the plastic sight shield covering the back of the headlamps by lifting up on the rear corners to release the velcro attachments. Lift the shield and pull towards the windshield.
3. At the back of the headlamp, pull up on the two right angle brackets to release the headlamp assembly from the vehicle.
4. Carefully pull the headlamp assembly away from the vehicle to expose the back of the bulb and wiring connector.
5. Remove the electrical connector from the bulb by grasping the wire with a quick pull rearward.
6. Remove the retaining ring by turning it 1/8 of a turn to free it from the socket. Then slide the ring off the plastic base of the bad bulb. **Keep the ring.** You must use it again to hold the new bulb in place.
7. Carefully remove the bulb assembly from its socket by gently pulling it rearward without turning.

Installing the headlamp bulb

1. With the flat side of the bulb's plastic base facing upward, insert the glass end of the bulb into the socket. You may need to turn the bulb left or right to line up the grooves in the plastic base with the tabs in the socket. When the grooves are aligned, push the bulb into the socket until the plastic base contacts the rear of the socket.

2. Slip the bulb retaining ring over the plastic base until it contacts the rear of the socket. Lock the ring into the socket by rotating it clockwise until you feel a "stop".
3. Push the electrical connector into the rear of the plastic base until it snaps, locking it into position
4. Carefully position the headlamp assembly onto the vehicle making sure the alignment pins are inserted into the proper holes
5. Hold the headlamp assembly snugly against the vehicle and push down on the right angle brackets to lock the lamp into position.
6. Install the plastic sight shield.
7. Turn the headlamps on and make sure that they work properly. If the headlamp was correctly aligned before you changed the bulb, you should not need to align it again..

Aiming Headlamps

Your vehicle is equipped with a Vehicle Headlamp Aim Device (VHAD) on each headlamp body. Each headlamp may be properly aimed in the horizontal direction (left/right) and the vertical position (up/down).

NOTE: A non-zero bubble reading does not necessarily indicate out-of-aim headlamps. If your vehicle is not positioned on a level surface, the slope will be included in the level indicator. Therefore, vertical headlamp adjustment should be

Tools required: One 4mm socket and ratchet.

The Horizontal aim must be adjusted first.

NOTE: The following procedure assumes that the vehicle's front structure is in factory alignment condition. If the vehicle has been in an accident requiring the front end of the vehicle to be repaired, the horizontal indicator should be recalibrated by the servicing facility.

Before adjusting your headlamps, you must make sure that the air suspension has been adjusted to the proper ride height. In order to do this:

1. Position the vehicle on a level surface.
2. Make sure the air suspension switch in the luggage compartment is in the ON position.
3. Turn the ignition key to the ON position.
4. Open and close the driver's door to allow the air suspension to fully level.

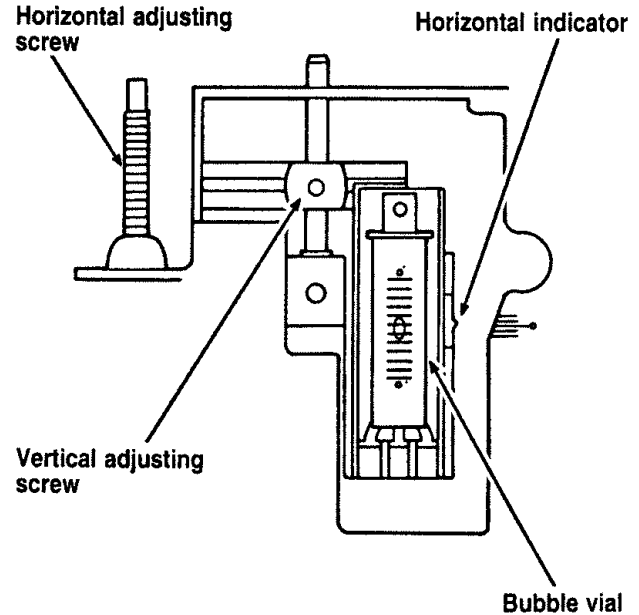

Horizontal aim adjustment

1. Open the hood and lift the front end cover from its velcro attachments. Locate the horizontal level indicator and adjustment screw.
2. Use a 4mm socket and ratchet to turn the horizontal adjusting screw until the horizontal indicator is in line with the "0" reference.

Vertical aim adjustment

NOTE: The numbers shown on the vial indicate beam direction in degrees up or down.

1. Locate the vertical level indicator and adjustment screw.
2. Use a 4mm socket and ratchet to turn the vertical adjustment screw until the bubble in the horizontal level indicator is centered in the vial.
3. Replace the front end cover and close the hood.

Bulb specifications

Function	Trade number
Exterior illumination	
Backup lamp	3156
Cornering lamp	3156
Headlamp	9007
High-mount brakelamp	912
License plate lamp	168
Luggage compartment lamp	912
Side marker - front lamp	916NA*
Side marker - rear lamp	194
Turn signal and park lamp - front	3457NA*
Turn signal, stoplamp and tail lamp - rear	3157
Redundant turn - rear	3157
Decklid reflector	168
Instrument panel lights	
Electronic automatic temperature control	***
Air bag readiness light	37
Anti-lock warning lamp	37
And-theft warning lamp	37
Ash receptacle	1445
Ash tray - rear doors	37
Clock	***

Function	Tradenummer
Instrument panel lights (continued)	
Cluster illumination	***
Cluster control button	37
Compact disc player	**
Glove compartment	194
Headlamp switch nomenclature	37
Message center control buttons	***
“PRN@D I” bulb (floor console)	194
Rear window defrost switch nomenclature	37
Radio	**
Warning lights (cluster)	37
Interior courtesy lamps	
Cigar lighter (door mounted)	1893
Door mounted lamp (front and rear)	214-2
Illuminated visor mirror (passenger)	74
Overhead console-reading lamps (without moon roof)	211-2
Passenger assist handle (rear seat)	211-2
Under instrument panel	906

*NA means Natural Amber.

**Refer bulb replacement to a Ford -authorized radio service center.

***Refer bulb replacement to a Ford or Lincoln-Mercury dealer.

Emission Control System

Your vehicle is equipped with three (3) catalytic converters which are used to enable your vehicle to comply with applicable exhaust emissions requirements.

⚠️ WARNING

Exhaust leaks may result in the entry of harmful and potentially lethal fumes into the passenger compartment. Under extreme conditions excessive exhaust temperatures could damage the fuel system, the interior floor covering, or other vehicle components, possibly causing a fire.

To make sure that the catalytic converters and the other emissions control parts continue to work properly:

- Use only premium unleaded fuel.

- Avoid running out of fuel.
- Do not turn off the ignition while your vehicle is moving, especially at high speeds.
- Do not push start your vehicle.
- Have the services listed in the *Maintenance Schedule and Record* booklet performed according to the specified schedule. The scheduled maintenance services are required because they are considered essential to the life and performance of your vehicle and to its emissions system.

In general, maintenance, replacement, or service of the emissions control devices or systems in your new Ford Motor Company vehicle or engine may be performed at your expense by any automotive repair establishment or individual using automotive parts equivalent to those which your vehicle or engine was originally equipped.

Ford strongly recommends the use of genuine Ford replacement parts. If other than Ford or Motorcraft parts or Ford authorized remanufactured parts are used for maintenance replacements or for the service of components affecting emission control, such non-Ford parts should be equivalent to genuine Ford Motor Company parts in performance and durability. It is the owner's responsibility to determine the equivalency of such parts. Please consult your warranty booklet for complete warranty information.

⚠ WARNING

Do not park, idle, or drive your vehicle in dry grass or other dry ground cover. The emission system heats up the engine compartment and exhaust system, which can start a fire.

Watch for fluid leaks, strange odors, smoke, loss of oil pressure, the charge warning light, the check

engine light, or the temperature warning light. These sometimes indicate that the emission system is not working properly.

Do not make any unauthorized changes to your vehicle or engine. Changes that cause more unburned fuel to reach the exhaust system can increase the temperature of the engine or exhaust system.

By law, anyone who manufactures, repairs, services, sells, leases, trades vehicles, or supervises a fleet of vehicles is not permitted to intentionally remove an emission control device or prevent it from working. In some of the United States and in Canada, vehicle owners may be liable if their emission control device is removed or is prevented from working.

Do not drive your vehicle if it does not operate properly. See your dealer if the engine runs on for more than five seconds after you shut it off or if it misfires, surges, stalls, or backfires.

Information about your vehicle's emission control system is on the Vehicle Emission Control Information decal located on or near the engine. This decal identifies engine displacement and gives some tune-up specifications.

Readiness for Inspection/Maintenance Testing

In some localities it may become a legal requirement to pass an Inspection/Maintenance (I/M) test of the On-Board Diagnostic (OBD) II system. If the vehicle's powertrain system or its battery has just been serviced, the OBD II system is reset to a not ready for I/M testing condition. To prepare for I/M testing, the law specifies a "need for additional mixed city and highway driving to complete the check" of the OBD II system. As soon as all of the OBD II system checks are successfully completed, the OBD II system is set to the ready condition. The amount of driving required to reach the ready condition varies with individual driving patterns. To complete this requirement in the

minimum amount of time, refer to the OBD II Drive Cycle defined below. If the vehicle owner cannot or does not want to do the additional driving required by law, a service center can perform this drive cycle as it would any other type of repair work.

OBD II Drive Cycle

The following steps must be run in the order shown. If steps 2 through 9 are interrupted, repeat the preceding step. Any safe driving mode is acceptable between steps.

Always drive vehicle in a safe manner according to traffic conditions and obey all traffic laws.

1. Start engine and drive until engine has reached normal operating temperature.
2. Idle vehicle for at least 80 seconds, then accelerate at part throttle to near 45 mph (72 km/h).

3. Drive to accumulate at least four (4) minutes in the range of 30-45 mph (50-70 km/h). If stop and go conditions occur, the accumulative time must be within the 30-45 mph (50-70 km/h) range. No wide open throttle conditions should be encountered.
4. Cruise and maintain a select speed in the range of 30-40 mph (48-64 km/h) on a level road with throttle held very steady for at least one (1) minute.
5. Decelerate and idle for at least 80 seconds.
6. Accelerate to 55 mph (90 km/h) at ½ throttle.
7. Decelerate at closed throttle for 10 seconds.
8. Cruise and maintain a select speed in the range of 40-65 mph (64-105 km/h) on a level road with throttle held very steady for at least 80 seconds.
9. Complete 10 minutes of city driving 25-40 mph (40-64 km/h) with at least six (6) stops.
10. OBD II drive cycle has been completed.
Vehicle can be turned off when convenient.

Refill Capacities, Motorcraft Parts, and Lubricant Specifications

Refill Capacities

Component	U.S.	Metric
Cooling system (including heater)	14.25 qts.	13.5 liters
Engine oil (with filter change)	6.0 qts.	5.7 liters
Transaxle Auto. overdrive	13.7 qts.	13.0 liters
Power steering	2.5 pints	1.2 liters
Fuel tank	17.8 gallons	67.4 liters
Pressure cap	16 psi	110 kPa

Motorcraft Parts

If you replace these parts ...		Use the Motorcraft Service Part with this part number
• spark plug*		AWSF-32EE**
• air filter		FA-1615
• fuel filter		FG-800A
• oil filter		FL-820
• battery	standard	BXT-65-850
<p>*Refer to Vehicle Emission Control Information (VECI) decal for spark plug and gap specifications.</p> <p>**If a spark plug is removed for examination, it must be reinstalled in the same cylinder.</p> <p>Cylinders #1, #2, 43, #4 have a EG suffix.</p> <p>Cylinders #5, #6, #7, #8 have a E suffix.</p> <p>If a spark plug needs to be replaced, use only spark plugs with the I service number suffix letter "FE" as shown on the engine decal.</p>		

Lubricant Specifications

Item	Ford Part No.	Part Name	Ford Specification
Brake Master Cylinder	C6AZ-19542-AA	Ford High Performance DOT 3 Brake Fluid	ESA-M6C25-A
Hinges, Door Latch, Hood Latch Auxiliary Latch, Trunk and Liftgate Latches	DOAZ-19584-AA	Multi-Purpose Grease Spray	ESB-MIC93-B
Lock Cylinders	E8AZ-19A501-B	Ford Penetrating Lubricant	N/A
Transaxle, Automatic	XT-2-QDX	Motorcraft MERCON® Auto. Trans. Fluid	MERCON®
Constant Velocity Joints Outboard and Inboard	E43Z-19590-A	CV Joint Grease - High Temp.	ESP-MIC207-A
Engine Coolant	E2FZ-19549-AA	Ford Premium Cooling System Fluid	ESE-M97B44-A
Power Steering (Pump Reservoir)	XT-2-QDX	Motorcraft Auto Trans. & Power Steering MERCON® ATF	MERCON®ATF
Engine Oil	XO-5W30-QSP	Motorcraft 5W30 Super Premium	ESE-M2C I 53-E and API Certification Mark
Door Weatherstrips	COAZ-19553-AA	Silicone Lubricant	ESR-MI3P4-A

NOTE: Rear axle lube quantities must be replaced every 100,000 miles (160,000 km) or if the axle has been submerged in water. Otherwise, the lube should not be checked or changed unless a leak is suspected or repair required.

Vehicle Storage

Maintenance Tips

If you plan on storing your vehicle for an extended period of time (60 days or more), refer to the following maintenance recommendations to ensure your vehicle stays in good operating condition.

General

- Store all vehicles in a dry, ventilated place.
- Protect from sunlight, if possible.
- If vehicles are stored outside, they require regular maintenance to protect against rust and damage.

Body

- Wash vehicle thoroughly to remove dirt, grease, oil, tar or mud from exterior surfaces, rear wheel housing and underside of front fenders.
- Periodically wash vehicles stored in exposed locations.
- Touch-up raw or primed metal to prevent rust.
- Cover chrome and stainless steel parts with a thick coat of auto wax to prevent discoloration. Re-wax as necessary when the vehicle is washed.
- Lubricate all hood, door and trunk lid hinges and latches with a light grade oil.
- Cover interior soft trim to prevent fading.
- Keep all rubber parts free from oil and solvents.

Engine

- Start engine every 15 days. Run at fast idle until it reaches normal operating temperature.
- With your foot on the brake, shift through all the gears while the engine is running.

Fuel system

- Fill fuel tank with high-quality, premium unleaded fuel until the first automatic shutoff of the fuel pump nozzle.

NOTE: During extended periods of vehicle storage (60 days or more), fuel may deteriorate due to oxidation. This can damage rubber and other polymers in the fuel system and may also clog small orifices.

Ford Gas Stabilizer should be added whenever actual or expected storage periods exceed 60 days. Follow the instructions on the label. The vehicle should then be operated at idle speed to circulate the additive throughout the fuel system.

A volatile corrosion inhibitor added to the fuel system will protect the fuel system's inner surfaces from corrosion. Follow the instructions packaged with the product.

Cooling system

- Protect against freezing temperatures.

Battery

- Check and recharge as necessary.
- Keep connections clean and covered with a light coat of grease.
 - If storing your vehicle for more than 30 days without recharging the battery, disconnect the battery cables to ensure battery charge is maintained for quick starting. NOTE: If battery cables are disconnected, it will be necessary to reset any memory features (eg. radio presets).

Brakes

- Make sure brakes and parking brake are fully released.

Tires

- Maintain recommended air pressures.

Miscellaneous

- Make sure all linkages, cables, levers and clevis pins under vehicle are covered with grease to prevent rust.
- Move vehicles at least 25 feet (8 m) every 15 days to lubricate working parts and prevent corrosion.

**YOU FOUND
THE RIGHT PLACE.**



Quality Care is more
than automotive service.

It's our goal to make you so
happy with your vehicle
and our service, you'll want
to come back. For service.
And your next car.

Quality Care.
It's at your dealer.

 **LINCOLN**
QUALITY CARE

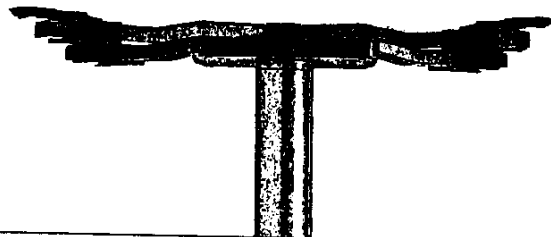

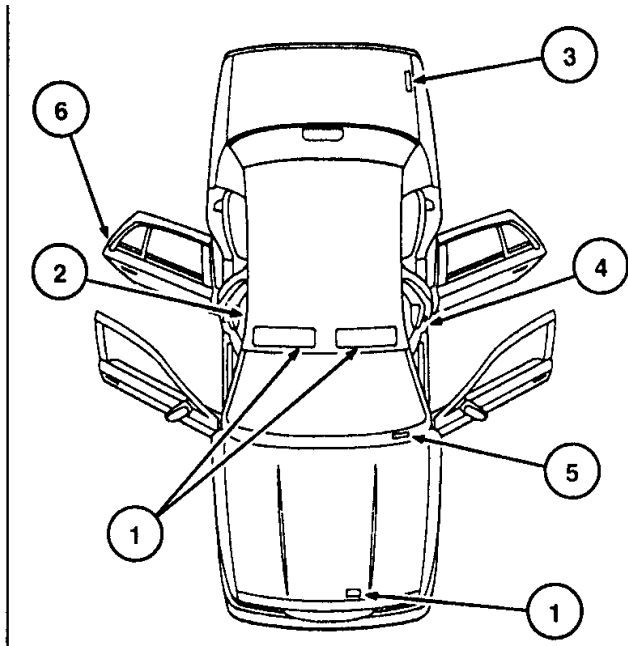

No.	Description	Refer to this label for information regarding:
1	Air Bag Warning Labels	Air bag precautions
2	Child Seat Label	Child seat installation precautions
3	Fuel Pump Shut-Off Label	Fuel pump shut-off location
4	Safety Compliance Certification Label	Name and date of manufacturer, GVWR*, GAWR**
5	Vehicle Identification Information Number (VIN) Label	Servicing or warranty information specific to your vehicle
6	Child Proof Lock Label	Operation of child proof lock feature

*Gross Vehicle Weight Rating **Gross Axle Weight Rating

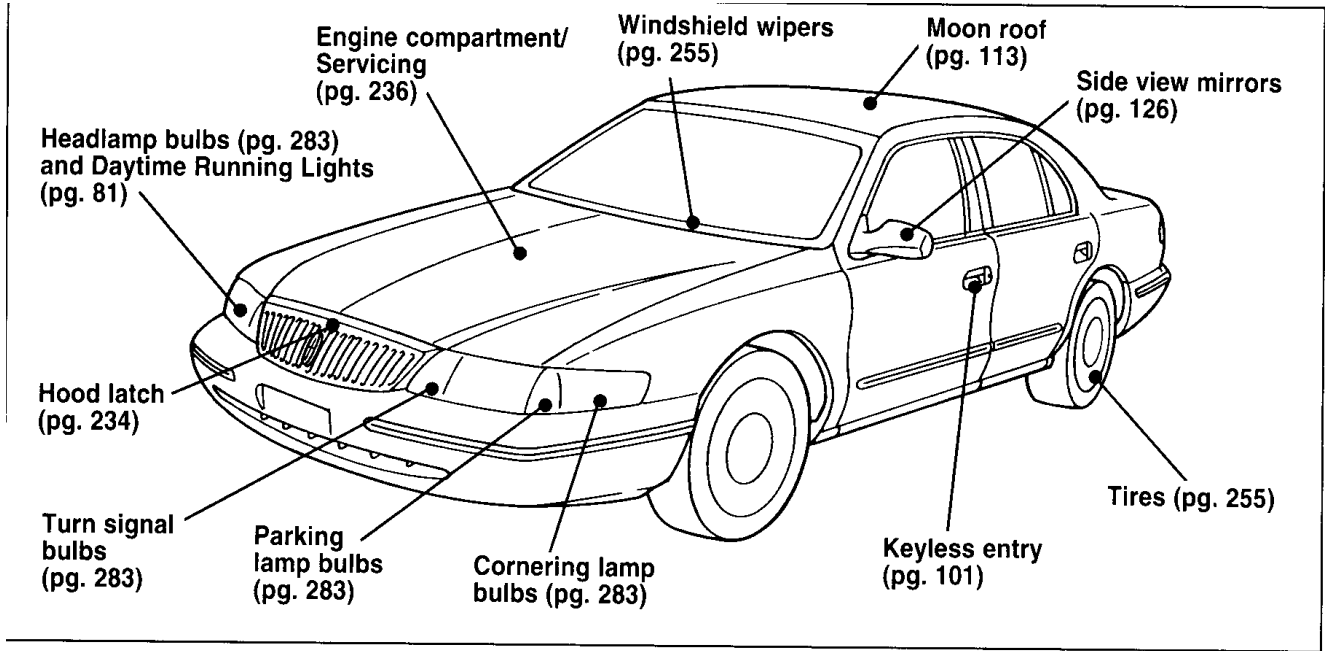

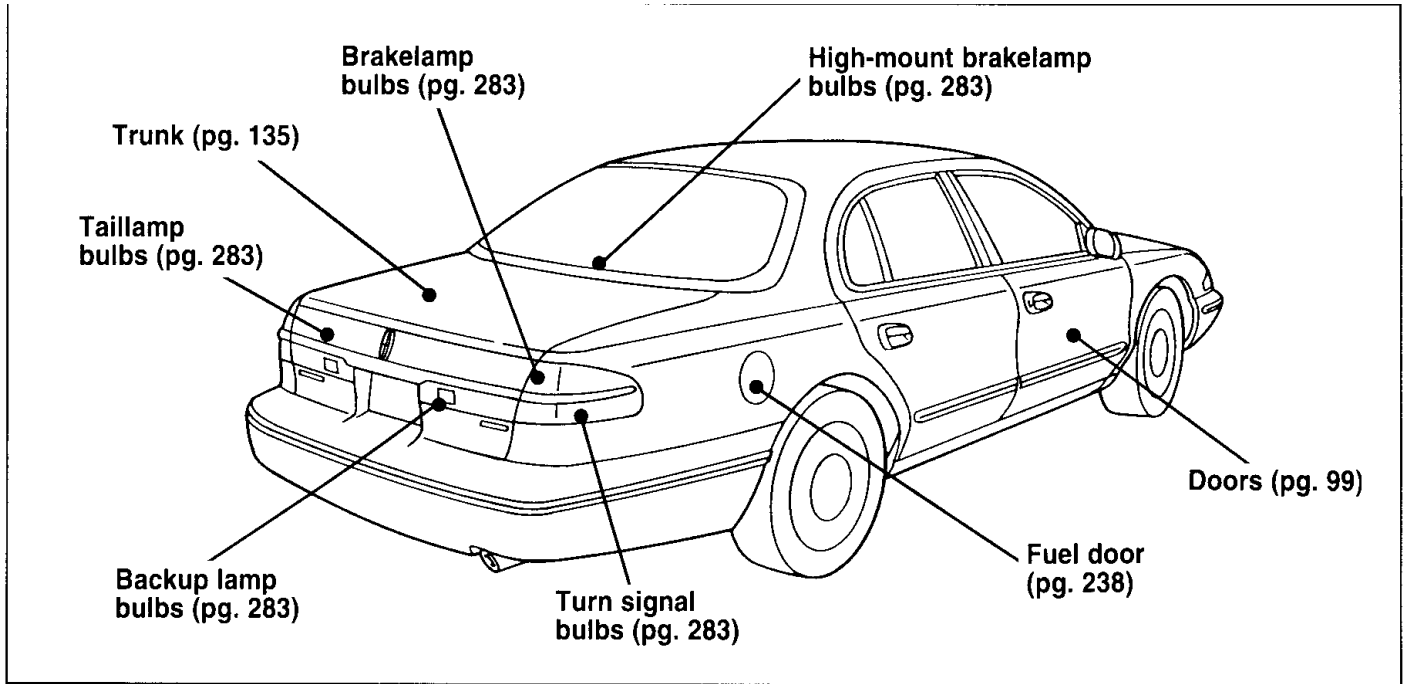

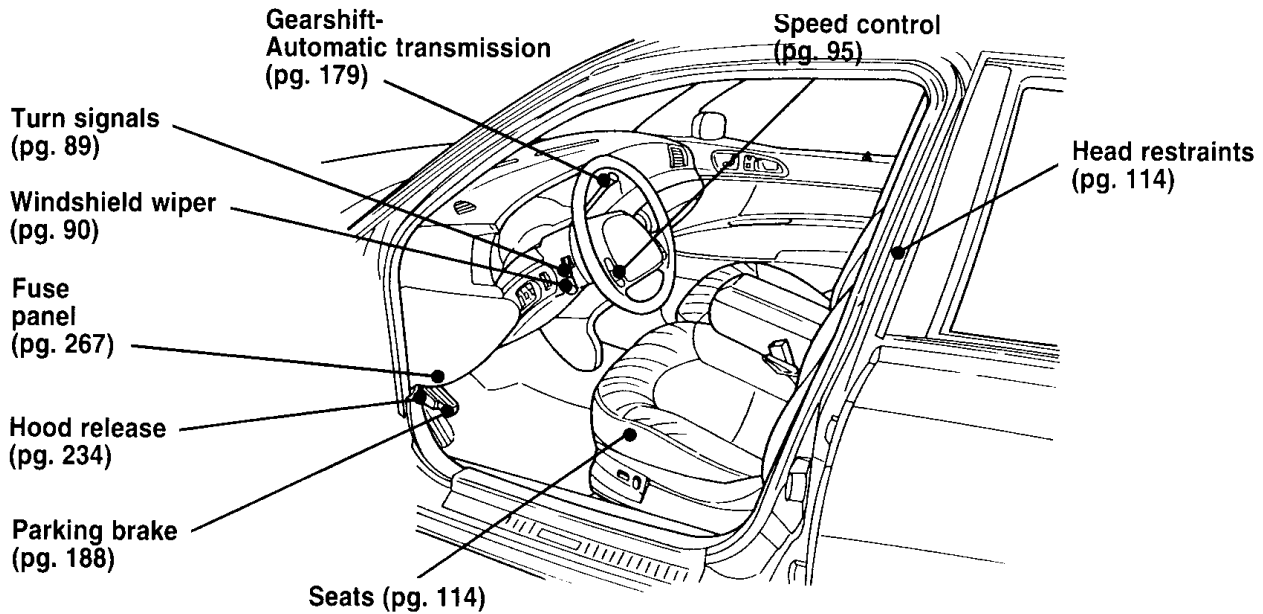

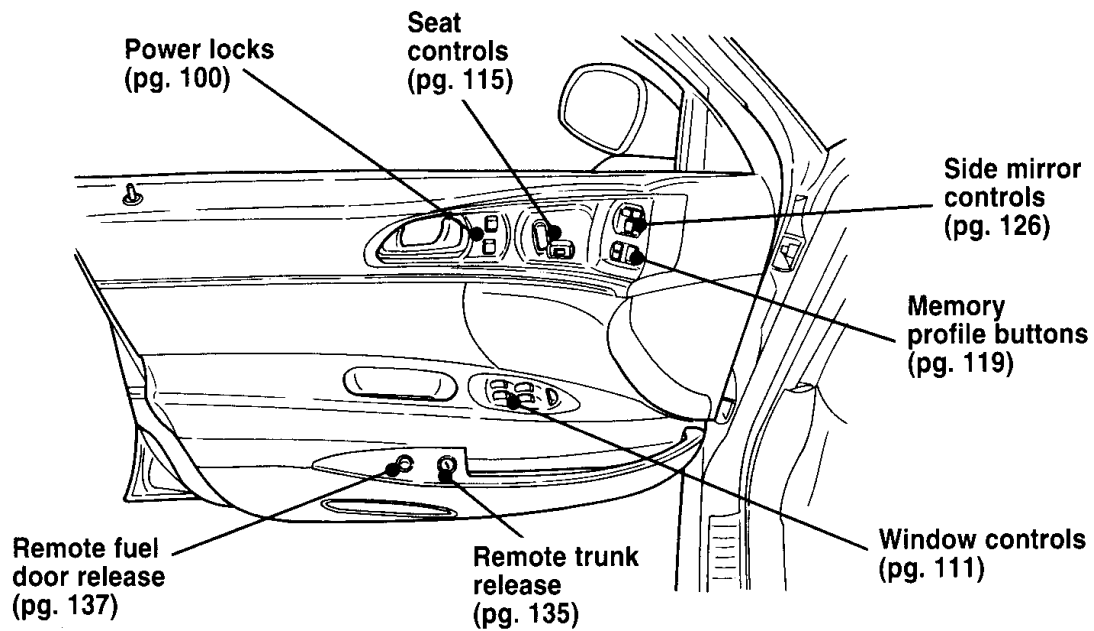

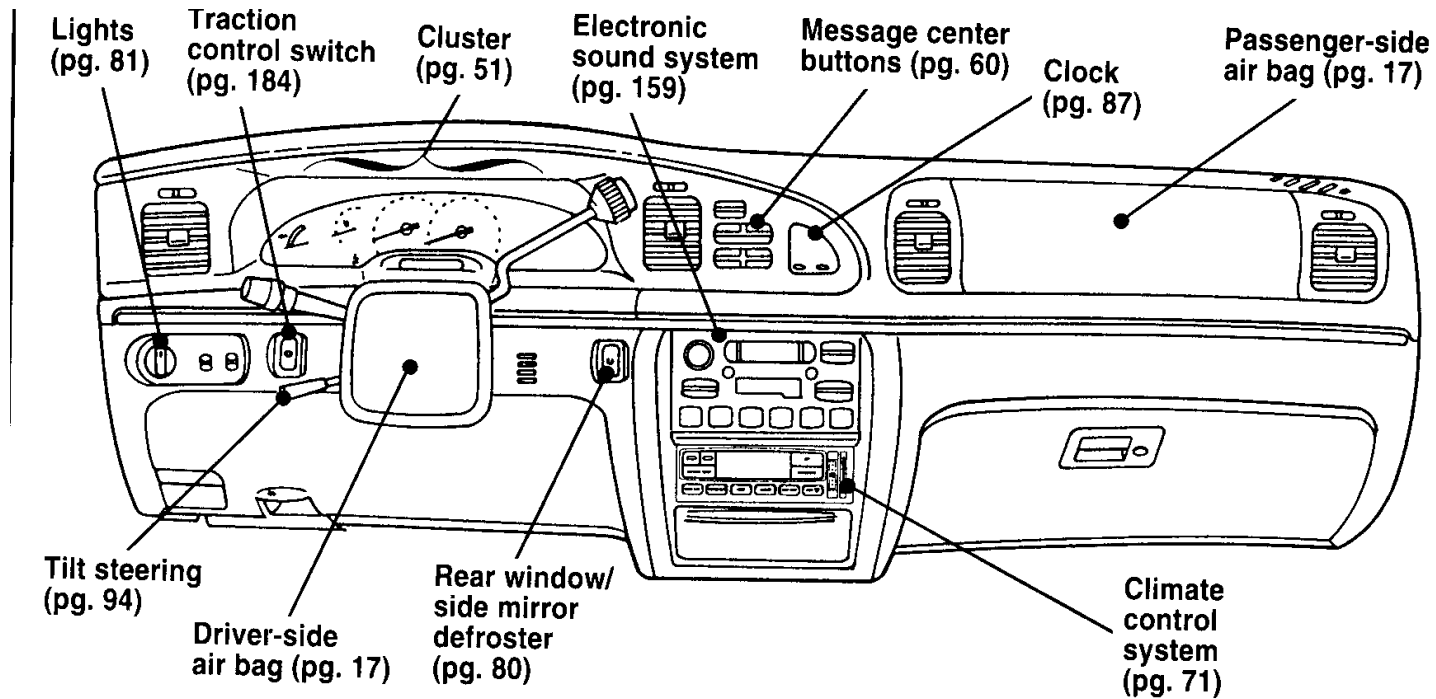

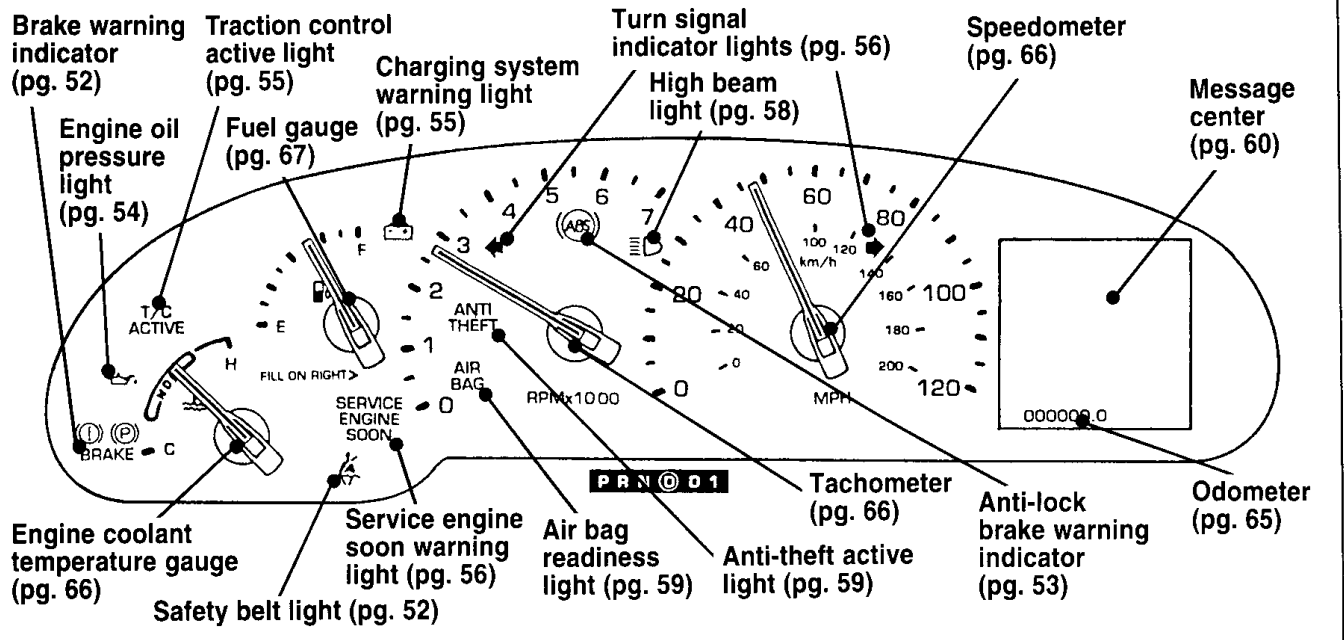

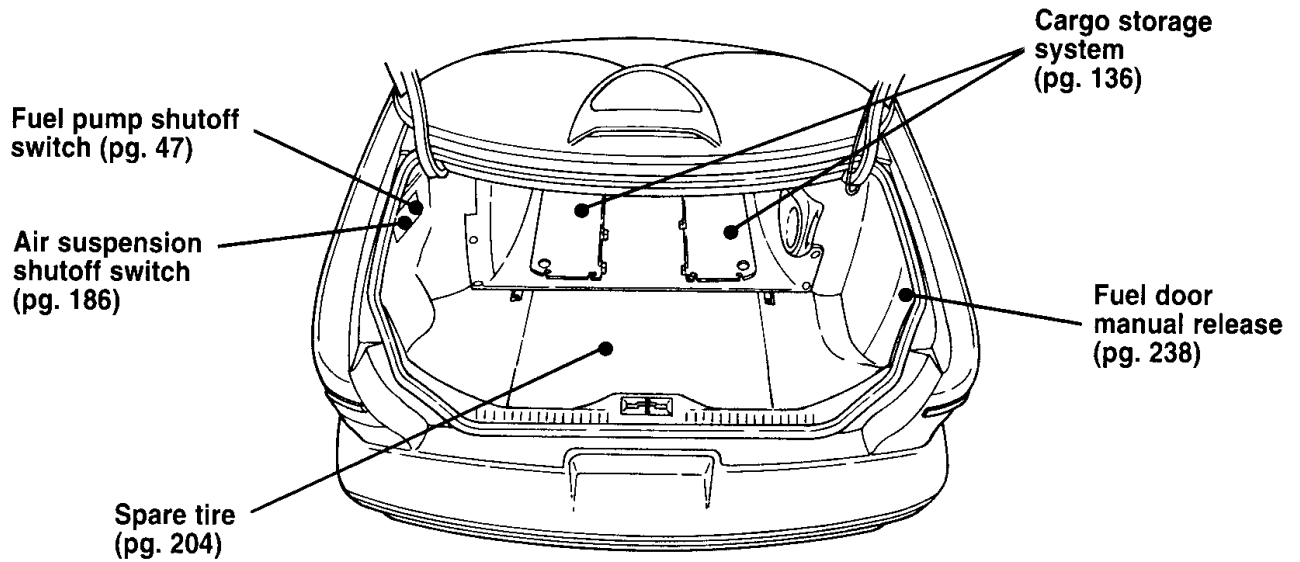

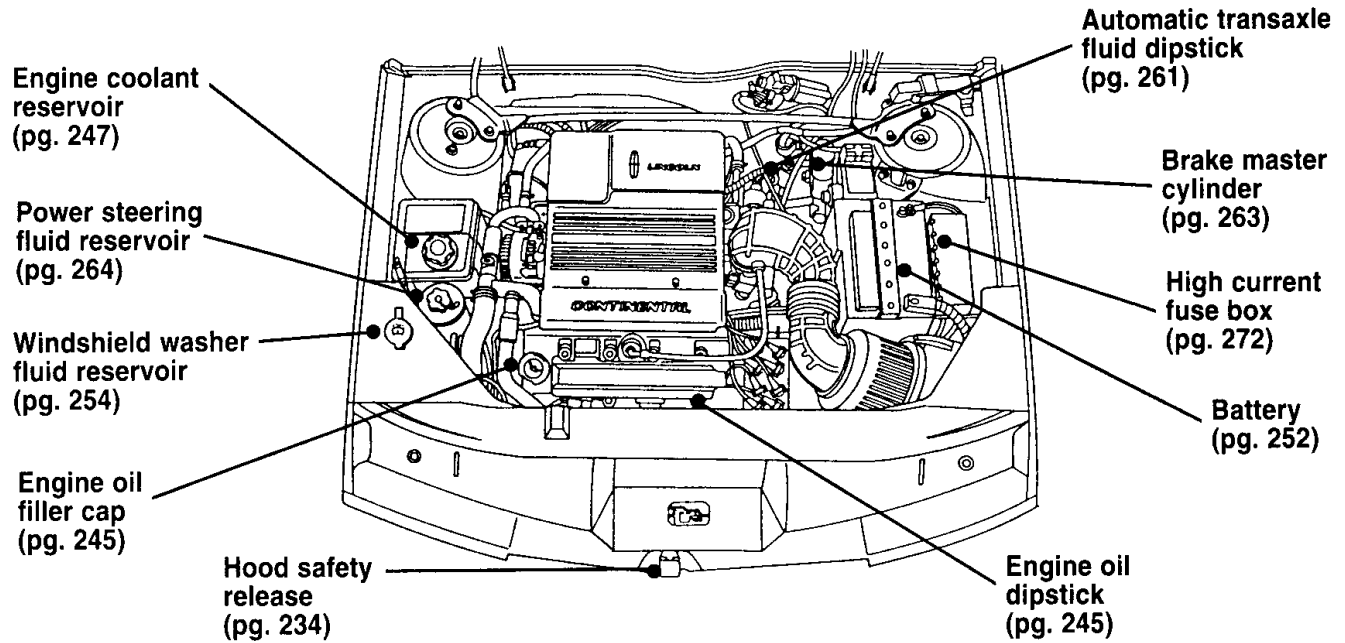

Index

A

- ABS warning light
 (see Anti-lock brake system) 53
- Accessory position on the ignition 41
- Accident damage 232
- Additives, engine oil 245
- Air bag supplemental restraint system
 description 17
 disposal 25
 indicator light 59
 operation 20
 proper seating 19
 tone generator 24
 wearing safety belts 18
- Air cleaner filter
 location 237
 specifications 288
- Air conditioning, electronic automatic
 temperature control system 71
- Air suspension
 air leveling disabled warning, message
 center 62
 description 186
- Alarm, activating remote personal 106
- Alcohol, in fuel 241
- Antenna, radio
 (see Electronic sound system) 165
- Antifreeze (see Engine coolant) 247
- Anti-lock brake system (ABS)
 description 187
 noise 187
 warning light 53
- Anti-theft lug nuts and key 209

applying the brakes.....	187	Catalytic converter	284
brake warning light.....	52	CD player (see Electronic sound system) .	169
fluid, checking and adding	263	Chains, tires	260
fluid, refill capacities.....	287	Changing a tire	204
fluid, specifications	289	Charging system warning light	55
new brake linings.....	6	Childproof locks	99
noise.....	188	Child safety restraints	25
parking.....	188	child safety belts	38
trailer	197	child safety seats	27
when storing your vehicle	292	Child safety seats	
Brake-shift interlock.....	180	attaching with tether straps	38
Break-in period	6	tether anchorage hardware	38
Bulbs, replacing.....	277	Chime	
headlamps.....	278	headlamps on	58
C		key in ignition	42
Canada, customer assistance.....	219	safety belt	52
Canadian Motor Vehicle Arbitration Plan (CAMVAP).....	220	Cleaning your vehicle	
Capacities for refilling fluids	287	chrome and aluminum parts	8
Carbon monoxide in exhaust.....	49	exterior	7
Car seats for children		exterior lamps	83
(see Child safety seats).....	27	fabric	118
		headlamps	83

Engine coolant temperature gauge, description	66	Fluid refill capacities	287
Engine fan	233	Ford Dispute Settlement Board	214
Engine oil		Ford Extended Service Plan	6
"break-in" oils	6	Ford Motor Company of Canada	219
changing oil and oil filter	247	Ford of Canada Customer	
checking and adding	245	Assistance Centre	219
dipstick	246	Foreign registration	221
disposal	232, 250, 262	French owner guides, how to obtain	3
engine oil pressure warning light	54	Fuel	
filter, specifications	288	calculating fuel economy	243
refill capacities	28-	capacity	287
specifications	289	choosing the right fuel	240
synthetic oil	245	comparisons with EPA fuel economy	
viscosity	245	estimates	243
Exhaust fumes	49	filling your vehicle with fuel	238
Extended Service Plan, Ford	6	filter, specifications	288
F		fuel gauge	67
Flashers, hazard	92	running out of fuel	242
Flashing the lights	90	safety information relating to	
Flat tire	204	automotive fuels	241
.....		storing your vehicle	291
		treating emergencies	241

Headlamps (continued).....		I
cleaning.....	83	Idle.....
daytime running lights.....	81	relearning.....
flashing.....	90	speed.....
high beam.....	90	Ignition.....
replacing bulbs.....	277	chime.....
turning on and off.....	82	positions of the ignition.....
warning chime.....	58	removing the key.....
Head restraints.....	114	Infant seats (see Safety seats).....
Heated mirrors.....	127	Instrument panel, location of components.....
Heating.....		Interval wipers.....
electronic automatic temperature.....	
control system.....	71	J
High beams, indicator light.....	58	Jack, operation.....
Hood.....		Jump-starting your vehicle.....
latch location.....	234,235	attaching cables.....
lubrication specifications.....	289	disconnecting cables.....
release lever.....	234	K
working under the hood.....	233	Keyless entry system.....
Horn.....	93	locking and unlocking doors.....
.....		programming entry code.....

Keys.....		charging system.....	55
key in ignition chime.....	42	engine oil pressure.....	54
positions of the ignition.....	41	high beam.....	58
removing from the ignition.....	42	oil pressure.....	54
stuck in lock position.....	42	safety belt.....	52
L		service engine soon.....	56
Lamps		turn signal indicator.....	56
autolamp delay system	83	Load limits	
checking	277	GAWR	192
.....		GVVVR.....	192
daytime running light system.....	81	trailer towing	194
flashing the lamps	90	Lubricant specifications	289
hazard flashers.....	92	Luggage compartment.....	135
headlamps.....	82	Lug nuts, anti-theft.....	209
high beams.....	90	
replacing bulbs.....	277	M	
trailer.....	197	Maintenance (see Servicing)	231
Lane change indicator (see Turn signal)....	89	Map pockets.....	134
Lights, warning and indicator		Methanol in fuel	241
air bag	59	Mileage, calculating fuel economy	243
anti-theft.....	59	Mirrors	
brake	52	automatic dimming rearview mirror..	125

R

Radio (see Electronic sound systems) ...	159
Rearview mirror	125
Refill capacities for fluids	287
Remote entry system	
arming and disarming the anti-theft system.....	106
locking/unlocking doors.....	105
opening the trunk.....	106
panic alarm	106
replacement/additional transmitters ..	107
replacing the batteries	106
RESCU system	144
Restraints, safety (see Safety restraints)	
adult	9
child	25
head	114
infant.....	25
Roadside emergencies	199
Rotating the tires.....	256

S

Safe driving tips.....	190
Safety belts (see Safety restraints).....	9
Safety chains, when towing a trailer	196
Safety Compliance Certification Label ..	192
Safety defects, reporting	218
Safety information relating to automotive fuels.....	241
Safety restraints	
adjusting the safety belts.....	12,16
cleaning the safety belts.....	17
extension assembly.....	16
for children	25
for infants	25
lap and shoulder belts.....	11
maintenance.....	17
replacement	17
warning light and chime	52
Safety seats for children	
and air bags.....	19,27
attaching with tether straps.....	38

Seats	removing the spare tire.....	205
adjusting the seats, power.....	temporary spare	204
child safety seats.....	Spark plugs, specifications.....	288
head restraints	Specification chart, lubricants	289
Securitre	Speed control	
Service concerns	accelerating.....	97
servicing	canceling a set speed	98
Shift-lock system.....	resetting.....	97
Shift positions (see Gearshift).....	resuming a set speed	98
Shoulder and lap belts	turning off.....	98
(see Safety restraints).....	when towing a trailer.....	198
Side mirrors	Speedometer.....	66
adjusting.....	Starting your vehicle	
heated	preparing to start your vehicle	43
Sliding moon roof (see Moon roof)	starting a cold engine	44
Snow tires and chains.....	starting after a collision	47
Spare tire	starting a warm engine	45
changing the tire	Steering, power	185
finding the spare	Steering wheel.....	
.....	horn	93
	tilting	94

Storage compartments	
center console.....	133
map pockets	134
Storing your vehicle	290
Sun visor.....	128
Supplemental air bag readiness light	59
Supplemental Restraint System (SRS)	17
T	
Tachometer.....	66
Tail lamps, cleaning.....	83
Tether anchor installation (see Child restraints)	38
Tilt steering wheel.....	94
Tires	
changing.....	204
checking the pressure.....	255,256
cleaning	260
replacing.....	257
rotating.....	256
snow tires and chains	260

storing your vehicle	292
tire grades	258
treadwear	257,259
wear bands	257
Towing a trailer (see Trailer towing)....	194
Towing your vehicle	211
Trailer towing	
calculating maximum trailer weight ..	194
safety chains.....	196
tips.....	198
trailer brakes	197
trailer lamps	197
Transaxle	
fluid, checking and adding (automatic)	261
fluid, refill capacities	287
lubricant specifications	289
Trunk, using the remote entry system to open	106

Windshield washer fluid and wipers	
checking and adding fluid.....	254
checking and replacing wiper blades . .	255
operation	90
reservoir	254

Service Station Information

Engine	4.6 Liter 4 Valve SFI (Sequential Fuel Injection) 8 Cylinder
Fuel	PREMIUM FUEL ONLY- Octane 91 or higher
Fuel Tank Capacity	17.8 gallons (68.1 Liters)
Tire Size	Refer to the Tire Pressure Decal
Tire Pressure	Front- 30 PSI, Rear- 28 PSI (measured cold)- Tire pressure decal on the front face of the passenger's door jamb.
Hood Release	Pull handle under left side of dash.
Engine Oil	Use only engine oil displaying the American Petroleum Institute Certification Mark- 5W30 preferred
Engine Oil Capacity	6.0 quarts (5.7 Liters).
Automatic Transmission	Motorcraft MERCON® (ATF),
Transaxle Capacity	13.7 quarts (13.0 Liters).
Power Steering Fluid	Use only power steering fluid that meets Ford Specification Motorcraft MERCON® ATF
Engine Coolant Capacity	14.25 quarts (13.5 Liters).