

Operating Manual  
Equipment  
– Viewvision





233-33148.024



**LOEWE.**

# Brief instructions for ViewVision

## Preparation

- Remote control TV mode 
- Remote control recorder mode 
- Switch unit on/off 
- Insert disk Button on the unit  – Insert disk – 

## Operating modes

MOVIE  – ◀ ▶ **MOVIE** – 











MUSIC  – ◀ ▶ **MUSIC** –  
▲ ▼ **DISC/USB** – 

PHOTO  – ◀ ▶ **PHOTO** –  
▲ ▼ **DISC/USB** – 



Disk menu 

Select title ◀ ▶ ▲ ▼ – 















## Playback

- Playback 
- Pause 
- Stop 
- Forwards (press several times) 
- Backwards (press several times) 
- Next/previous section **P+/-**
- Volume **V+/-**
- Individual frame  ◀ / ▶
- Slow motion  ◀◀ / ▶▶ (press several times)
- Jump forwards 30 sec. 
- Detailed information 
- Title menu  

## Recorder/TV operation

- Select channel  or **P+/-**
- Picture-in-picture during playback 

## Recording

- Insert disk  – Insert recordable disk – 
- Select signal source  or **P+/-**
- Start recording manually 
- Stop recording manually 
- Programme timed recording   – Enter data –  – 
- ShowView  – Enter data –  – 
- Timer overview 
- Terminate menu 
- Recording of Loewe SAT-TV See operating instructions for Loewe TV

# Remote control Assist – recorder operation

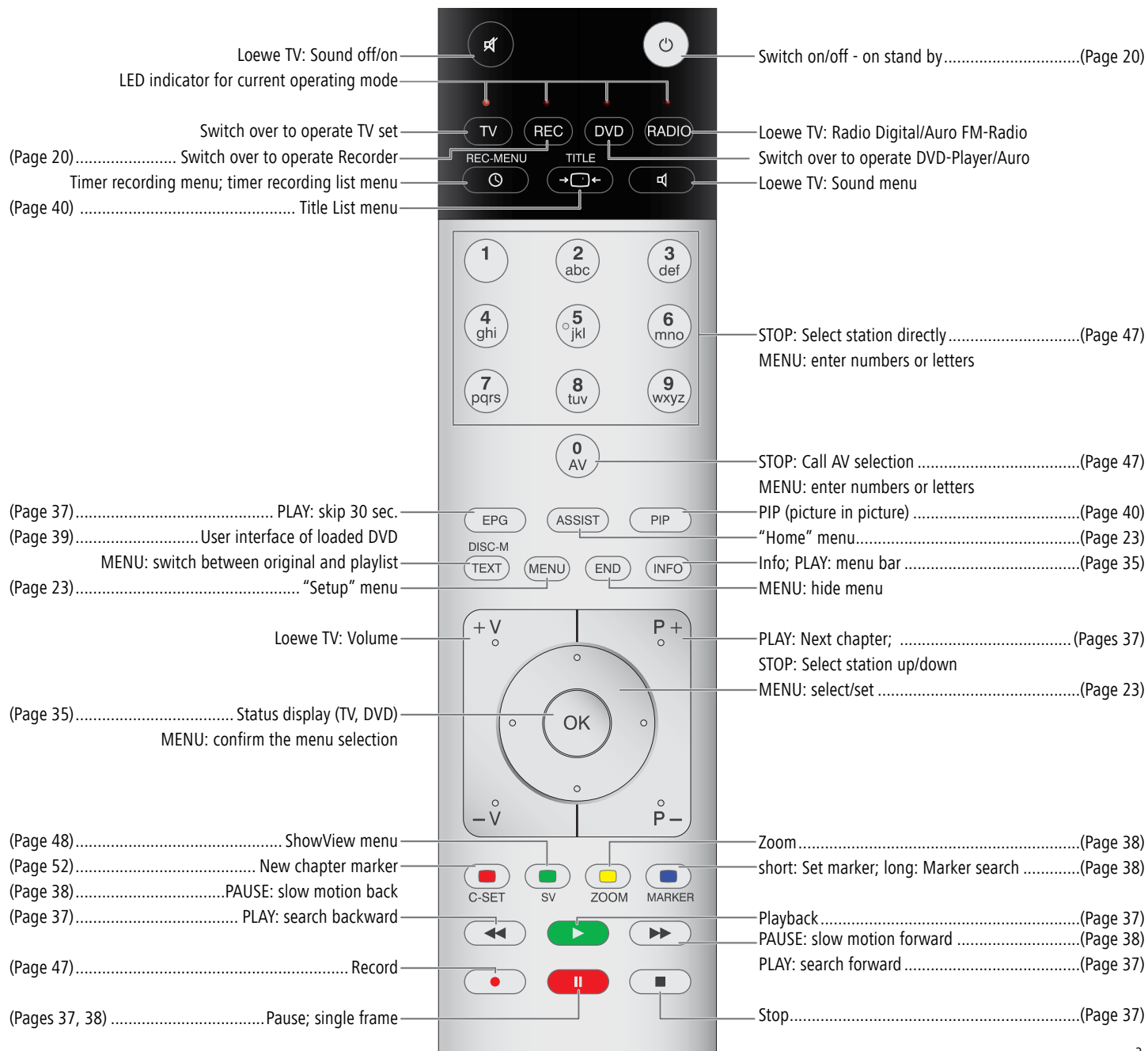

# Index

## A

Area Code 31  
Auto Chapter 32  
Automatic programming 24

## B

Basic Settings 20  
Brief instructions 2

## C

Card-Reader 45  
Chapter List 51  
Clock set 27  
COMPONENT VIDEO OUT 7  
Connections 16  
    Accessories 19  
    Aerial 16  
    Amplifier 19  
    Camcorder 20  
    Decoder 18  
    General 16  
    Satellite Receiver 18  
    Set-top box 18  
    Television 16  
Copy protection system 14  
Copyright 14  
CPRM 14

## D

Delete Station 26  
Digital Link 11,20  
Digital Link Plus 11,24  
DIGITAL OUT 7  
Digital Video 49  
Disc-related Terms 15  
Disc Format 32  
Disc Label 33  
Disc Protect 34  
Display 7  
Disposal 11  
DivX registration code 31  
Dolby Digital 29  
DTS 29  
DV IN 6

## E

Edit recordings 51  
    Add chapter markers 52  
    Combine chapters 56  
    Create new Playlist 52  
    Delete part 54  
    Divide title 56,58  
    Edit thumbnail 52  
    Move Playlists Chapters 57  
    Protect title 57  
    Title Name 55

## F

Finalisation 33  
Front Panel 6

## G

Glossary 65

## H

HDMI 7,36

## I

IN from ANT. 16  
Initialisation 28  
Inserting/removing memory  
    cards 45

## M

Main menu 21  
Mains cable 7  
Masthead 61  
Moving stations 26  
MPEG 29

## O

Operating additional devices  
    8  
OPTICAL 7  
OUT (TO TV) 16

## P

Photo mode 44  
Picture in Picture (PIP) 40  
Playable Discs 14  
Playback 37  
    3D-Surround 39  
    Audio CD 42  
    Camera positions 39  
    CHAPTER 37  
    Compatibility 43  
    Disc menu 39  
    Freeze frame 38  
    Markers 38  
    MP3/WMA media 42  
    Random play 43  
    Repeat 38  
    Search 37  
    Skip 37  
    Slow Motion 38  
    Subtitles 40  
    Time 38  
    TITLE 37  
Playback  
    DivX files 41  
Playing on other devices 58  
Playlist 52  
Program Edit 25  
Progressive Scan 16

## R

Rating 30  
Rear Panel 7  
Recording 47  
    Digital Video 49  
    Manual Record 47  
    Record from external  
        sources 49  
    ShowView 48  
    Simultaneous record and  
        display 47  
    Timer Recording 47  
    Timer Record List 48  
Regional code 15  
Remote Control 16  
Resetting 16  
Rewritable discs 13

## S

S-VIDEO OUT 7  
Safety 12  
Scope of delivery 10  
Screen Menus 35  
Service 64  
Set Password 29  
    Delete 30  
    Switching off 30  
Set up 10  
Setup menu 23  
    Audio Menu 29  
    Disc Menu 32  
    General Menu 24  
    Language Menu 28  
    Lock Menu 29  
    Recording Menu 31  
Slide Show 44  
Station Rename 26  
Symbols 15

## T

Technical Specifications 61  
Title List 51  
Trademark rights 10  
Troubleshooting 59–60

## V

VIDEO OUT 7

# Contents

|   |           |  |           |
|---|-----------|--|-----------|
| <b>Brief instructions for ViewVision</b> .....          | <b>2</b>  | <b>Operating convenience</b> .....                     | <b>35</b> |
| <b>Remote control Assist – recorder operation</b> ..... | <b>3</b>  | Additional Screen Menus .....                          | 35        |
| <b>Index</b> .....                                      | <b>4</b>  | <b>HDMI mode</b> .....                                 | <b>36</b> |
| <b>Front Panel</b> .....                                | <b>6</b>  | <b>Video mode</b> .....                                | <b>37</b> |
| <b>Rear Panel &amp; Display</b> .....                   | <b>7</b>  | Playing back a DVD.....                                | 37        |
| <b>Operating additional devices</b> .....               | <b>8</b>  | Playing discs or USB devices with mixed contents ..... | 40        |
| Setting the remote control .....                        | 8         | PIP (Picture In Picture) .....                         | 40        |
| Operating Loewe equipment.....                          | 8         | <b>DivX mode</b> .....                                 | <b>41</b> |
| <b>Remote control Assist – TV operation</b> .....       | <b>9</b>  | <b>Audio mode</b> .....                                | <b>42</b> |
| <b>Welcome</b> .....                                    | <b>10</b> | <b>Photo mode</b> .....                                | <b>44</b> |
| Scope of delivery.....                                  | 10        | <b>USB mode</b> .....                                  | <b>45</b> |
| Set up.....   | 10        | <b>Recording</b> .....                                 | <b>47</b> |
| Shipping the Unit.....                                  | 11        | Manual Record .....                                    | 47        |
| Disposal.....   | 11        | Timer Recording.....                                   | 47        |
| Advantages of connection to a Loewe TV set .....        | 11        | Timer recordings with the ShowView® system.....        | 48        |
| <b>For your safety</b> .....                            | <b>12</b> | Timer Record List.....                                 | 48        |
| <b>Essential Information</b> .....                      | <b>13</b> | Record from external sources.....                      | 49        |
| Recordable discs.....                                   | 13        | Digital Video.....                                     | 49        |
| Playable Discs.....                                     | 14        | <b>Edit recordings</b> .....                           | <b>51</b> |
| Notes on Discs.....                                     | 15        | Menu Title List and Chapter List.....                  | 51        |
| Disc-related Terms.....                                 | 15        | Edit Original and Playlist.....                        | 52        |
| Symbols.....  | 15        | Add chapter markers.....                               | 52        |
| <b>Initial Installation</b> .....                       | <b>16</b> | Create new Playlist.....                               | 52        |
| Initial Remote Control Setup .....                      | 16        | Add title/chapter to the Playlist.....                 | 53        |
| Switching over to Progressive Scan .....                | 16        | Delete title/chapter from Original/Playlist.....       | 54        |
| Connections - General.....                              | 16        | Delete part.....                                       | 54        |
| Connecting to the Aerial.....                           | 16        | Title Name .....                                       | 55        |
| Connecting to the Television .....                      | 16        | Select title start point.....                          | 55        |
| Alternative connections.....                            | 16        | Select chapter .....                                   | 55        |
| Connecting to a Loewe TV System.....                    | 17        | Divide title .....                                     | 56        |
| Connecting to a set-top box / Satellite Receiver.....   | 18        | Combine chapters.....                                  | 56        |
| Connecting to an External Decoder Box .....             | 18        | Move Playlists Chapters .....                          | 57        |
| Connecting to an Amplifier .....                        | 19        | Hide title/chapter .....                               | 57        |
| Connecting Audio/Video (A/V) Accessories .....          | 19        | Protect title .....                                    | 57        |
| Connect to the mains.....                               | 20        | Overwrite recordings.....                              | 58        |
| Basic Settings .....                                    | 20        | Title List menus on other devices.....                 | 58        |
| Activating Digital Link.....                            | 20        | Playing on other devices .....                         | 58        |
| Resetting the DVD Recorder.....                         | 20        | <b>Troubleshooting</b> .....                           | <b>59</b> |
| Auto Setup.....   | 21        | <b>Technical Specifications</b> .....                  | <b>61</b> |
| Menu overview .....                                     | 22        | Masthead .....   | 61        |
| Main menu (HOME).....                                   | 23        | <b>Language Code List</b> .....                        | <b>62</b> |
| Setup menu .....  | 23        | <b>List of country codes</b> .....                     | <b>63</b> |
| The General Menu.....                                   | 24        | <b>Service</b> .....                                   | <b>64</b> |
| Language Menu.....                                      | 28        | <b>Glossary</b> .....                                  | <b>65</b> |
| Audio Menu.....   | 29        |  |           |
| Lock Menu.....  | 29        |  |           |
| Recording Menu .....                                    | 31        |  |           |
| Disc Menu .....   | 32        |  |           |

# Front Panel

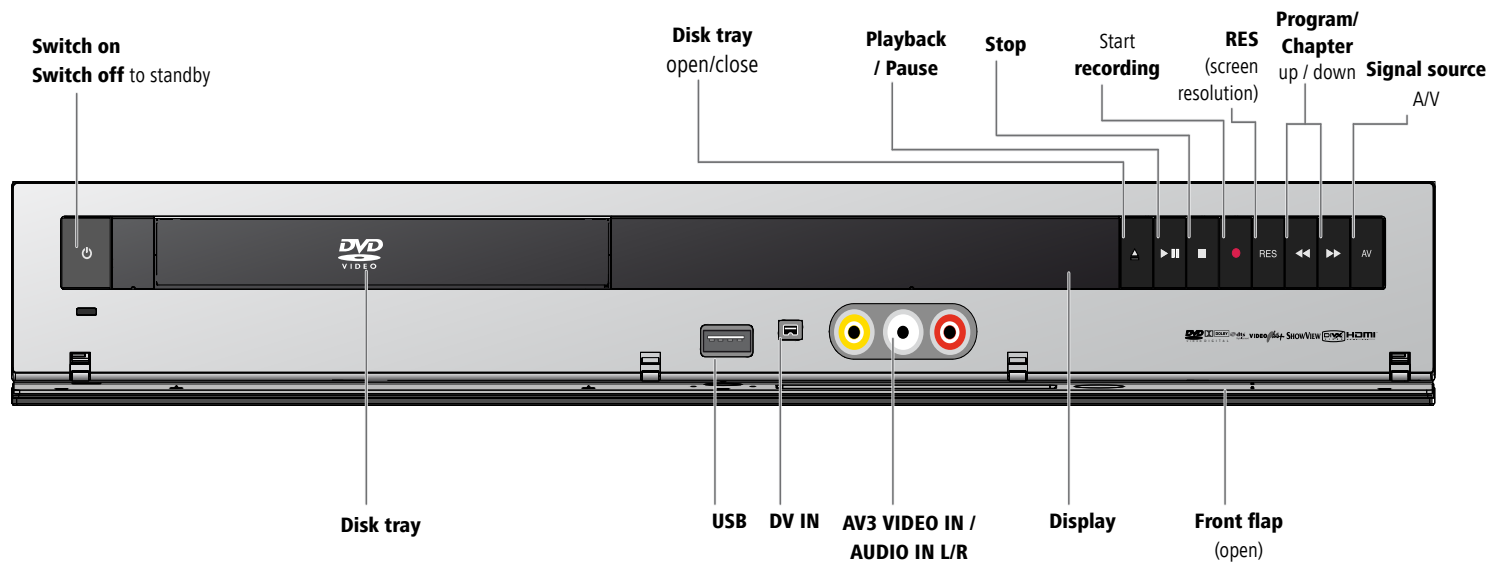

# Rear Panel & Display

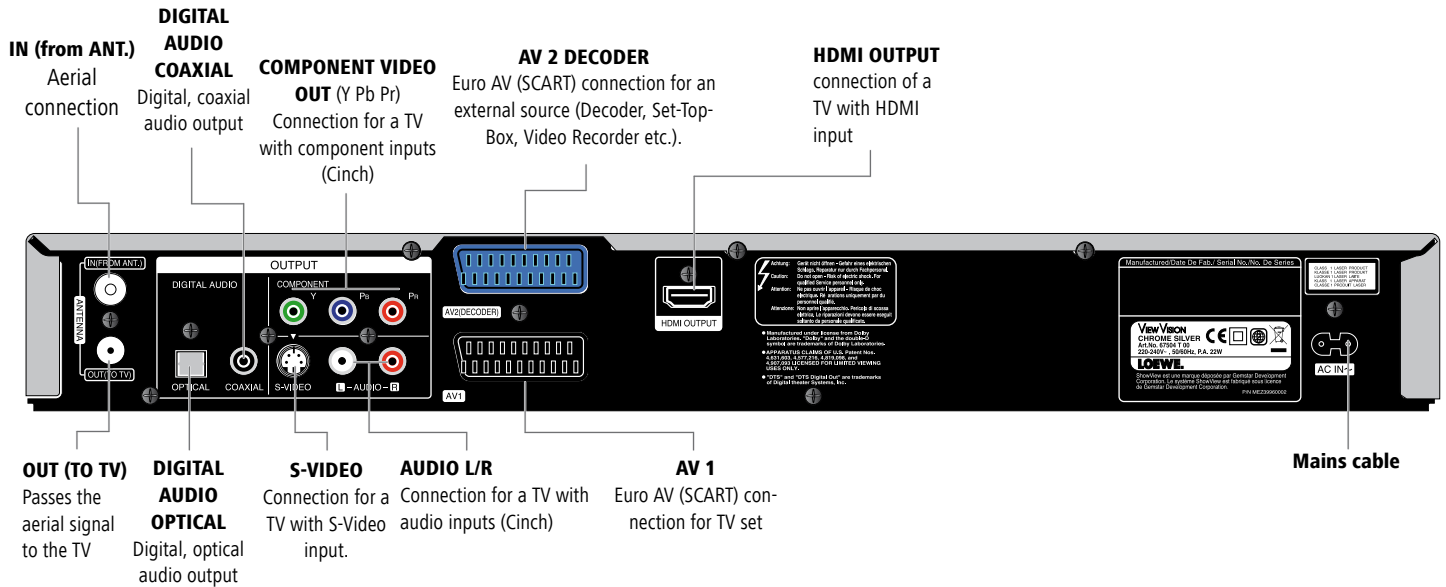



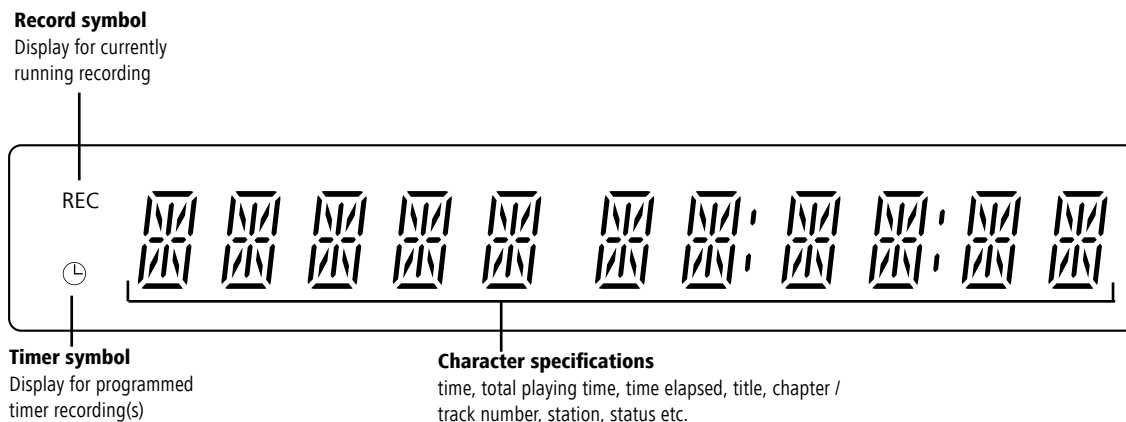















**Caution:** Do not touch the inner pins of connection sockets on the rear panel. Electrostatic discharge may cause permanent damage to the unit.



# Operating additional devices

## Setting the remote control

The different Loewe sets can be set as follows on the Assist remote control:

| Device                          | Button combination  |   |
|---------------------------------|---|---|
| Loewe TV (Chassis L2650 ≥ V4.4) |  +  | * |
| Loewe TV (Chassis L2600)        |  +  |   |
| Loewe TV (Chassis Q25x0)        |  +  |   |
| Loewe Centros 11x2              |  +  |   |
| Loewe ViewVision, Centros 21x2  |  +  | * |
| Loewe ViewVision DR+ / DVB-T    |  +  |   |
| Loewe ViewVision 8106 H         |  +  |   |
| Loewe Auro 2216 PS/8116 DT      |  +  | * |
| Loewe Xemix 6222 PS             |  +  |   |

\* Factory setting

The specified key combination must be pressed (approx. 5 s) until one of the LEDs flashes twice.

## Operating Loewe equipment

### Using the remote control for a DVD player

 Press the **DVD** button, the indicator above it lights for about 5 seconds.

### Using the remote control for a recorder

 Press the **REC** button, the indicator above it lights for about 5 seconds.

### Using the remote control for a TV set

 Press the **TV** button, the indicator above it lights for about 5 seconds.

Every time you press the button, the indicator of the selected operating mode (TV – REC – DVD – RADIO) lights up.

# Remote control Assist – TV operation

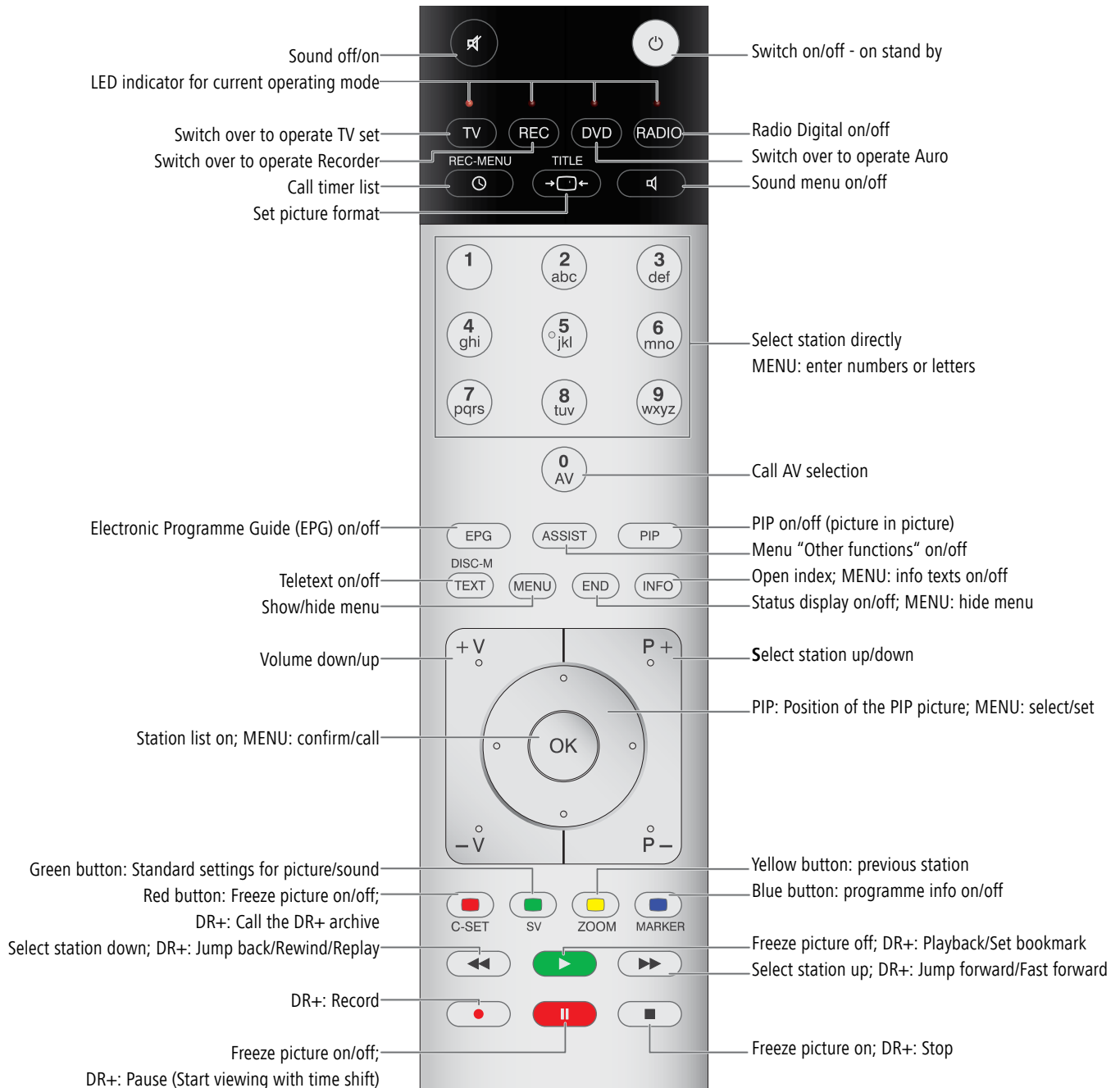

# Welcome

## Thank you

for choosing a Loewe product. We are happy to welcome you as our customer. At Loewe we combine the highest standards of technology, design and user friendliness. This is equally true of TV, DVD, video, audio and accessories.

Neither technology nor design is an end in itself, but both are intended to provide our customers with the best possible audio and visual experience. Our design is not influenced by short-term, fashionable trends. You have, after all, purchased a high-quality piece of equipment which you do not want to get tired of looking at tomorrow or the day after.

You can control three devices with the Assist remote control. In addition to this recorder also a Loewe TV set and a Loewe DVD player or a Loewe Audio System (page 8).

## Scope of delivery

- Recorder Loewe ViewVision
- Assist remote control with 2 batteries
- AV cable (Scart cable)
- Antenna cable
- HDMI cable
- 1x DVD-RW disk
- this operating manual

## Trademark rights

Manufactured under license from Dolby Laboratories. Dolby, ProLogic and the double-D symbol are trademarks of Dolby Laboratories.

“DTS” and “DTS Digital Out” are trademarks of Digital Theater Systems, Inc. ShowView is a registered trademark of Gemstar Development Corporation. The ShowView System is manufactured under license from Gemstar Development Corporation.

HDMI, the HDMI Logo and High-Definition Multimedia Interface are trademarks or registered trademarks of HDMI licensing LLC.

## Set up

- Place the recorder on a firm, level base.
- Do not place the recorder in the vicinity of sources of intense heat or in direct sunlight.
- When installing in a cabinet or enclosed shelf: Leave at least 2.5 cm free around the recorder to allow unhindered circulation of air and avoid build-up of heat. Do not cover up fan and openings on the rear.
- There can be interference to the images and sound of any nearby television, video recorder or radio. If this is the case, do not position the unit in the direct vicinity of a TV set, video recorder or radio, or switch the unit off after removing the disk.
- Position the recorder so that the infrared signal of the remote control can reach the display of the recorder unobstructed (or if this is not possible, see “Advantages of connection to a Loewe TV set”, page 11).
- Do not place strong artificial light sources in front of the device. This may affect infrared reception.
- Incorrect voltages can damage the device. This device may only be connected to a power supply with the voltage and frequency specified on the rating plate, using the power cable provided.
- If there is an electrical storm, disconnect the antenna and mains plug. Power surges caused by lightning strikes can damage the unit through the antenna system or the mains.
- The antenna and mains should also be disconnected if the unit is to remain unsupervised for a long period of time.
- The mains plug must be easily accessible so that the unit can be disconnected at any time.
- Lay the cable in such a way that it cannot get damaged. The power cable should not be kinked or laid over sharp edges, not stood upon or exposed to chemicals - the latter also applies to the device as a whole. A mains cable with damaged insulation can cause electric shocks and is a fire hazard.
- Do not tug the cable when you remove the mains plug but hold the plug by the housing. The wires in the mains plug may be damaged and cause a short-circuit when you plug it back in.

You should also read and follow the safety advice on the following pages.

# Welcome

## Shipping the Unit

The original shipping box and packaging materials should be used to ship the unit. To give the unit the best possible protection, repack it as it was originally packed by the manufacturer.

## Disposal

### Cardboard box and packaging

In line with national regulations regarding the disposal of packaging materials, we pay a fee to authorised recyclers who collect packaging from dealers. However, we recommend that you keep the original cardboard box and the rest of the packaging materials so that the unit can, if necessary, be transported in the safest possible conditions.

### The unit

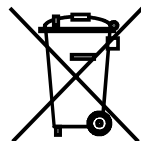

**Important:** The EU Directive 2002/96/EG governs the proper re-acceptance, handling and recycling of used electronic appliances. Old electronic appliances must therefore be disposed of separately. Never throw this set in the normal domestic waste. You can hand in your old set free of charge at identified collection points or at your dealer if you buy a similar new set. Other details about re-acceptance (also for non-EU countries) are available from your local administration.

### Remote control batteries

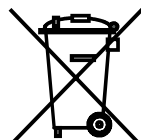

The batteries provided contain no harmful materials such as cadmium, lead or mercury. Regulations concerning used batteries mean that batteries may no longer be thrown out with the household rubbish. You can dispose of used batteries free of charge at the collection points in commercial outlets. Your dealer will also have a collection point for used batteries.

## Advantages of connection to a Loewe TV set

With **Digital Link** you can install the recorder for example in a closed rack or a cupboard without direct visual contact with the recorder. With the DVD remote control, you operate the recorder via the Loewe TV set. **Digital Link** must be switched on on the recorder (page 20).

If you use the HDMI connection, the TV set is automatically switched over to this input if your TV set supports this function.

If you want to make timer recordings from the TV satellite tuner, **Digital Link Plus** controls the recording. With **Digital Link Plus** the station data of the aerial and cable stations of the TV set are transferred to the recorder so that the same stations are saved in the same order in both devices. This enables timer recordings of aerial and cable stations to be made comfortably on the TV set with the EPG (Electronic Program Guide). The timer data are transferred to the recorder which then makes the timer recording independently of the TV set. For timer data for satellite stations, the TV set starts and stops the recorder and sets it to the Euro AV 1 input. When play is started, this is shown immediately on the TV set regardless of which TV station you are currently watching (if the TV is switched off, it will be switched back on automatically first).

# For your safety

For your own safety and to avoid unnecessary damage to your unit, please read and follow the safety advice below:

## Use for the intended purpose and ambient conditions

This recorder is intended exclusively for the reception, recording and playing of video and audio signals and is designed for the home and office and may not be operated in rooms with a high **humidity** (e.g. bathroom, sauna) or high **concentration of dust** (e.g. workshops).

The terms of the warranty only cover normal use of the recorder.

If the device is used outdoors, make sure that it is protected against **moisture** (rain, drips and splashes or dew). High humidity and dust concentrations lead to leak currents in the device which may lead to electric shocks or fires.

If you have moved the device out of the **cold** into a warm environment, leave it switched off for about an hour to avoid formation of **condensation**.

Always switch off your system (Viewvision, TV set and any other audio components which may be connected) before connecting or disconnecting other devices or loudspeakers.

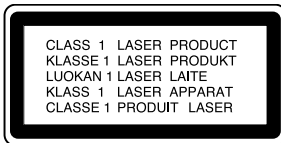

Do not open up the housing, or you could be directly exposed to the laser beam. The laser beam will be visible if the unit is open.

## DO NOT LOOK INTO THE LASER BEAM.

Protect your recorder from:

- liquids and damp
- shock and mechanical stress
- magnetic and electrical fields
- cold, heat, direct sunlight and extreme fluctuations in temperature
- dust
- anything which obstructs ventilation
- manual interference with the unit's interior

**PLEASE NOTE: TO AVOID RISK OF ELECTRICAL SHOCK, DO NOT REMOVE THE COVER (OR THE REAR OF THE UNIT). THERE ARE NO PARTS INSIDE THE UNIT THAT CAN BE REPAIRED BY THE USER. REPAIRS SHOULD ONLY BE CARRIED OUT BY A LOEWE DEALER.**

Only use **original accessories** such as Loewe installation systems if possible.

## Supervision

Do not allow **children** to use the recorder/TV set unsupervised. Do not allow children to play in the immediate vicinity of the recorder/TV set. They could knock, push or pull the equipment over and cause injury.

## Cleaning

Only clean your recorder with a slightly damp, soft, clean cloth (without any aggressive cleaning agents).

If the recorder does not read a disk correctly, the reading unit in the device may be soiled. Use a commercially available cleaning disk.

Keep the disk drawer closed to prevent dust from the drawer getting onto the lens.

## About this user guide

The information in this guide refers to the Loewe product Viewvision and Viewvision Secam - (version for France).

Unless stated otherwise, the instructions refer to the operating elements on the Assist remote control.

The explanations for DVDs in this guide refer to the DVDs recorded with this recorder. They do not apply for DVDs recorded on other recorders and played on this recorder.

Paragraphs beginning with the **►** symbol indicate important hints, tips or conditions for perfect operation.

Terms which you will find in the menu or printed on the recorder are printed in **bold** type.

In the functional descriptions, the necessary operating elements are arranged to the left of the text which contains the handling instructions.

Please read this operating manual to understand this device and its possibilities. The individual chapters are inter-related.

The index/glossary at the end of this manual explains certain terms which are used in the user interface of the device and in the operating manual.

# Essential Information

## Recordable discs

### DVD-RW (Digital Versatile Disc - ReWritable)



DVD-RW discs can be formatted for recording in the VR mode or in the video mode. These discs can be rewritten several times. Recordings can be deleted and the disc can then be rewritten.

**VR mode** Recordings can be extensively edited.

They can only be played on VR mode compatible players (after finalisation).

**Video mode** Limited editing possible.

Play on normal DVD players (after finalisation).

### DVD-R (Digital Versatile Disc - Recordable)



These discs can be recorded once. A DVD-R disc cannot be rewritten or edited after finalisation. DVD-R discs can only be formatted for recording in video mode. Play on normal DVD players (after finalisation). Limited editing possible.

### DVD+RW (Digital Versatile Disc + ReWritable)



DVD+ReWritable

These discs can be rewritten several times. Recordings can be deleted and the disc can then be rewritten. Play only on DVD+RW-compatible players (automatic finalisation). Edited contents can only be played after finalisation on DVD+RW-compatible players. Titles/chapters of recordings can be edited.

### DVD+R (Digital Versatile Disc + Recordable)



DVD+R

These discs can be recorded once. A DVD+R disc cannot be rewritten or edited after finalisation. Play only on DVD+R-compatible players (after finalisation). Edited contents can only be played after finalisation on DVD+R-compatible players. Title/chapters can be edited conditionally.

- ▶▶▶ This recorder cannot write to CD-R or CD-RW discs.
- ▶▶▶ This recorder cannot write data discs (e.g. no MP3 or JPEG files).
- ▶▶▶ The displayed recording time is not exact because the recorder uses a variable bit rate video compression. This means that the exact recording time depends on the contents being recorded.
- ▶▶▶ When recording a television broadcast the remaining recording time may be shorter if the reception is poor or the picture contains interference.
- ▶▶▶ If you record only still pictures or audio, the recording time may be longer.
- ▶▶▶ The displayed recording time and remaining time may not always add up to the total length of the disc.
- ▶▶▶ The available recording time may be shorter following intensive editing of the disc.
- ▶▶▶ If you use a DVD-R disc you can continue recording until the disc is full or until you finalize it. Before you start recording check how much recording time is available on the disc.
- ▶▶▶ If you use a DVD-RW disc in video mode, the available recording time is extended again when you delete the last title recorded on the disc.
- ▶▶▶ The **Delete Parts** function (page 54) only hides the title but does not delete it from the disc and does not extend the recording time (except for the last recorded title on a DVD-RW disc in video mode).
- ▶▶▶ Overwrite recording is only possible on DVD+RW discs (page 58).

# Essential Information

## Recording TV-Audio Channels

This recorder can also record NICAM audio. If the NICAM setting (page 27) is set to "Auto", NICAM audio will be recorded in the case of a NICAM transmission.

## Restrictions on Video Recording

- You cannot record movie material with copy protection with this recorder. If a copy protection is encountered during recording, the recording stops or is interrupted automatically and a message is displayed on the screen.
- A video that can only be copied once can only be recorded using a DVD-RW disc in VR mode with CPRM (see below).
- NTSC format signals from analog or DV inputs cannot be recorded correctly with this recorder.
- SECAM format video signals (from an integrated TV tuner or from analog inputs) are recorded in PAL format.

## CPRM

CPRM is a copy protection system (with scramble system) that only allows the recording of "copy once" broadcasts. CPRM is the abbreviation for "Content Protection for Recordable Media".

This recorder is CPRM compatible. You can therefore record copy-once broadcasts but cannot make copies of these recordings. CPRM recordings are only possible with VR mode formatted DVD-RW discs and can only be played on players with CPRM compatibility.

## Copyright

- The recording equipment should only be used for lawful copying. You should find out what constitutes lawful copying in the country in which you are making a copy. Copying of copyrighted material e.g. films or music is only lawful if permitted by a legal exception or consented to by the rights owner.
- The product contains copyright protection technology through certain US patents and other intellectual property rights and is the property of the Macrovision Corporation and other companies. Use of this protection technology must be authorized by the Macrovision Corporation. It is only intended for private or other limited use unless otherwise authorized by the Macrovision Corporation. Reverse engineering and disassembly are prohibited.

## Playable Discs



Video-DVD (8 cm- / 12 cm disc)



Audio-CD  
(8 cm- / 12 cm disc)



CD-R/RW

DVD-R/DVD-RW discs, DVD+R/DVD+RW discs, CDR/CD-RW discs with audio titles, DivX, \*MP3/WMA or JPEG files and Kodak Picture-CDs (JPEG) can also be played on this unit.

\* including MP3 discs with ID3-Tag.

- ▶▶▶▶ DVD-R/RW, DVD+R/RW and CD-R/RW discs written to using a PC or a DVD or CD recorder cannot be played if the disc is damaged or dirty or if there is condensation on the recorder's lens.
- ▶▶▶▶ If you record a disc using a PC, even if it is in a compatible format, the disc may not play depending on the settings of the application software used to create the disc. (Further information can be obtained from the software provider).
- ▶▶▶▶ Depending on the recording unit or the CD-R/RW (or DVD±R/±RW) disc itself, some CD-R/RW (or DVD±R/±RW) discs cannot be played with this unit.
- ▶▶▶▶ Do not attach any labels to either side (the labeled side or the written side) of a disc.
- ▶▶▶▶ Do not use any irregularly shaped CDs (e.g. heart-shaped or octagonal). If you use these discs malfunctions may occur.
- ▶▶▶▶ Fingerprints and scratches on the disc can affect playback and/or recording. Take proper care of your discs.

# Essential Information

## Regional code of the Recorder and DVDs



This Recorder can only play Region "2" or "all" coded DVDs.

The region code on the label of some DVDs shows which type of DVD recorder can play those discs. If you play other discs the error message "Incorrect region code. Playback not possible." will be displayed on the TV screen.

Some discs may not have the label with the region code even though they cannot be played in all regions.

## Notes on Discs

### Handling Discs

Do not touch the prerecorded side of the disc. Hold the disc at the edges so as not to touch the surface with your fingers. Do not stick paper or tape to either side of the disc.

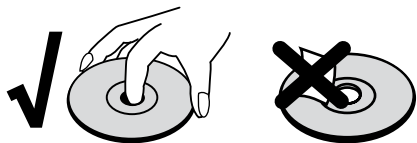

### Storing Discs

After playing, store the disc in its case. Do not expose the disc to direct sunlight or a source of heat and never leave it in a parked car exposed to direct sunlight as there may be a considerable increase in temperature inside the car.

### Cleaning Discs

Fingerprints and dust on the disc can affect the picture and sound quality. Clean the disc before playing it with a clean cloth. Wipe the disc from the center outwards.

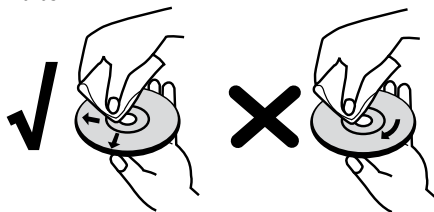

Do not use any strong solvents such as alcohol, benzene, thinner, commercially available cleaners or anti-static sprays intended for vinyl records.

## Disc-related Terms

### Title

A title is the main movie content or the music album. You have easy access by the title number.

### Chapter (DVD)

Chapters are movie sequences or a piece of music which are parts of a title. You have easy access by the assigned chapter number.

### Track (only Audio-CD)

A piece of music on an Audio-CD. You have easy access by the assigned track number.

## Symbols

### The symbol on the screen

During operation,  may appear on the screen. This symbol means that the desired function is not available at the moment.

### Disc symbols in the operating instructions

If part of the operating instructions contains one of the symbols listed below, the section is only applicable to the disc shown on the symbol.

Many functions of this recorder are dependent on the selected recording quality. One or more of the symbols are displayed for each function described in the manual so that you can immediately see whether the disc supports this function.

*DVD ALL* All DVDs listed below

*-RW Video* DVD-RW Disc with video mode

*-RW VR* DVD-RW Disc with VR mode

*-R* DVD-R disc

*+R* DVD+R disc

*+RW* DVD+RW disc

*DVD-V* DVD-Video disc

*CD* Audio CD

*DivX* DivX/Xvid files

*MP3* MP3 files

*WMA* WMA files

*JPEG* JPEG files

# Initial Installation

## Initial Remote Control Setup



To insert or change the batteries, press on the imprinted arrow. Slide off and remove the battery compartment cover. Insert alkaline-manganese LR 03 (AAA) type batteries and make sure the + and – poles are aligned correctly. Then, replace the cover.

## Switching over to Progressive Scan

With the “Progressive Scan” mode you get the best possible picture quality without flicker in the “Component Video” mode in display units which support this operating mode.

- ➡ Your recorder must be switched on. An HDMI cable is not plugged.

Button **on the recorder.**



On: **576 P** appears briefly in the recorder display.

Off: **576 I** appears briefly in the recorder display.

## Connections - General

- ➡ Depending on your television set and the other units you want to connect, there are several ways of connecting your recorder to your TV set. Only use the connection methods described below.
- ➡ Refer as necessary to the manuals for your television, recorder, stereo system and other units in order to make the best possible connections.
- ➡ The recorder must be connected directly to the TV set. Use the “connection wizard” for this in Loewe TV sets.
- ➡ Do not connect the Recorder **AUDIO OUT** socket to the audio system Phono In socket.

## Connecting to the Aerial

Remove the existing aerial cable plug (**R**) (for analog, terrestrial or cable TV) from the TV and plug it into the aerial socket on the back of the recorder (**IN from ANT.** socket). Then plug one end of the aerial cable provided into the TV socket on the recorder (**OUT (TO TV)**) and the other end into the aerial socket on the TV.

## Connecting to the Television

Make the following connections depending on the scope of functions of your existing equipment (page 17)

When connecting to a LOEWE TV set, the recorder must be logged in to the connection wizard of the TV set at the appropriate connection first.

### Euro AV1 connection

Connect the **AV1** scart socket of the recorders to the appropriate input socket on the TV with the scart cable.

### HDMI connection

Connect the **HDMI OUT** socket of the recorder to the HDMI input socket on the TV set with the HDMI cable provided (HDMI socket 1 in Loewe). Make the settings as described on page 36. The SCART connection is required additionally for recording from the TV set.

## Alternative connections

### S-Video connection

Connect the **S-VIDEO OUT** socket of the recorder to the S-Video input socket of the TV set with the S-Video cable.

### Component Video connection

Connect the **COMPONENT VIDEO OUT** sockets on the recorder to the appropriate input sockets on the TV set with a Y Pb Pr cable (available from your dealer).

### Audio connection (left/right)

Connect the left and right **AUDIO OUT** socket of the recorder to the left and right **AUDIO IN** sockets on the TV set with the audio cables.

### Digital Audio output

Connect the **DIGITAL-OUT** socket of the recorder to the **DIGITAL-IN** socket of the surround amplifier.

# Initial Installation

## Connecting to a Loewe TV System

Make the connections as shown here:

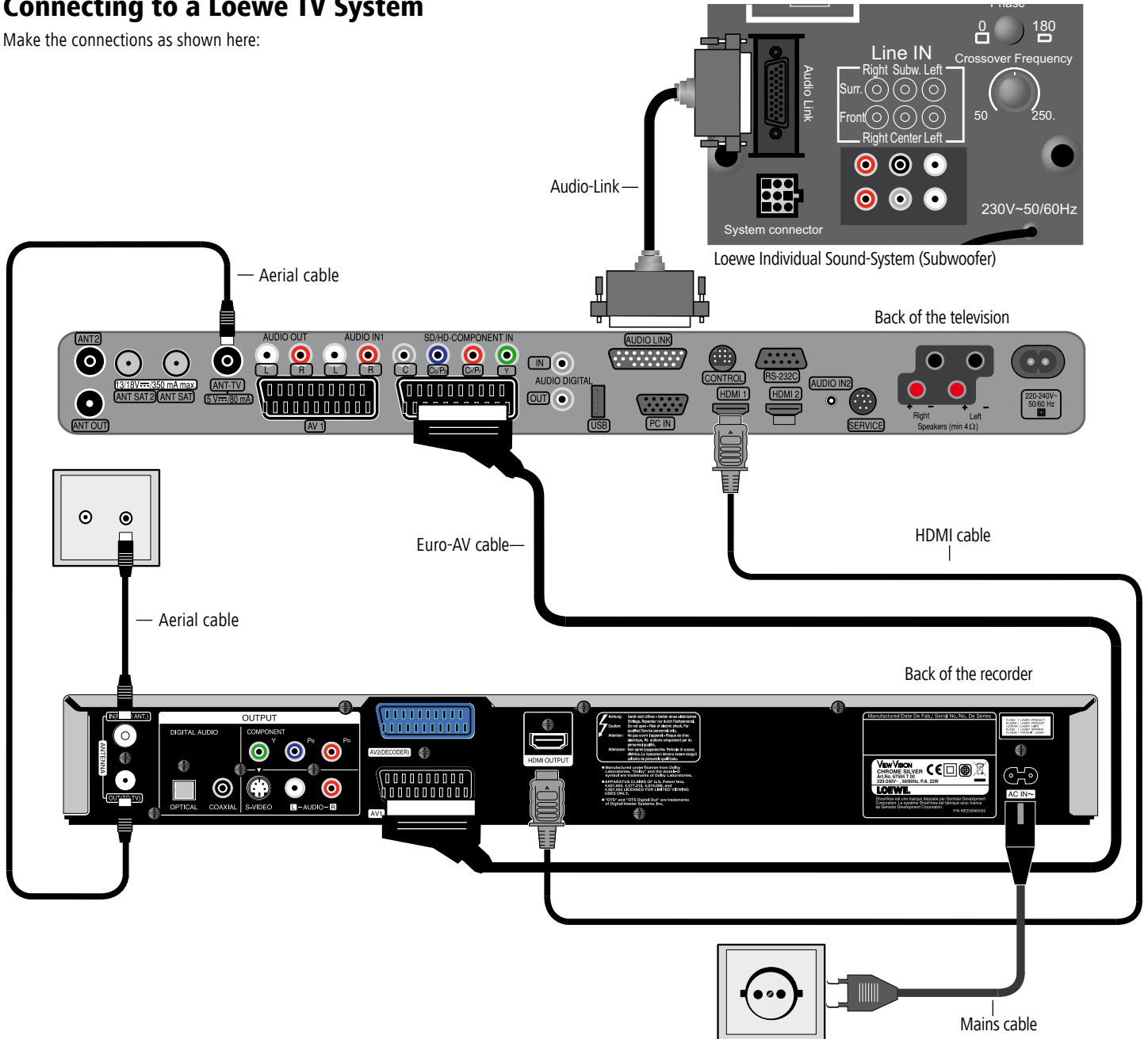

# Initial Installation

## Connecting to a set-top box / Satellite Receiver

If you use a cable or satellite receiver with integrated decoder, connect it to your recorder and television set as described below. If you use a separate decoder box for your cable/satellite television, follow the instructions in the next section "Connecting to an External Decoder Box".

1. Connect the aerial cable as shown. This enables you to watch and record TV channels.
2. Connect the **AV1** connection to an AV socket on your TV set with the Scart cable. This enables you to view discs.
3. Connect the **AV2 DECODER** connection to an AV socket on your set-top box / your satellite receiver. This enables you to watch its TV channels.

► This recorder is equipped with a "Loop-Through" function. The function enables you to record a TV program from the integrated analog terrestrial TV tuner of this recorder while watching a satellite or set-top box channel. Do not connect the recorder "via" your video recorder, satellite receiver or set-top box.

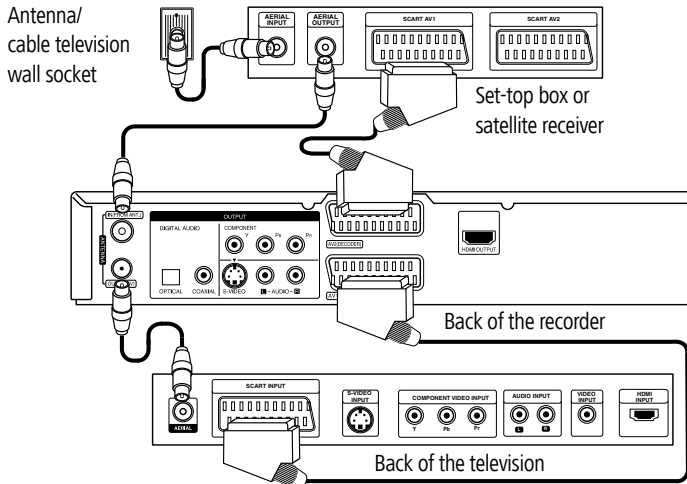

## Connecting to an External Decoder Box

If you use an external decoder box for your satellite or cable TV system, follow the connection procedure described below.

1. Connect your aerial socket in the wall to the aerial input socket on your set-top box / satellite receiver using an aerial cable.
2. Connect the decoder to the AV DECODER socket on the set-top box /satellite receiver using a SCART cable. Further instructions can be found in the manual for your decoder box.
3. Connect the AV2 socket on the DVD recorder to an **AV 2** socket on your set-top box / satellite receiver using a SCART cable.
4. Connect the AV1 socket on the DVD recorder to a **AV 1** socket on your television using the SCART cable.

- Do not connect the Decoder-Box directly to the recorder but as shown in the figure below to the satellite/set-top box.
- Stations from the decoder (e.g. via Pay-TV services) can only be viewed when the recorder is switched off (standby mode).
- For timer recordings to work properly on this recorder, the satellite / set-top box must also be switched on during recording.
- With this configuration you cannot watch one television broadcast and record another at the same time.

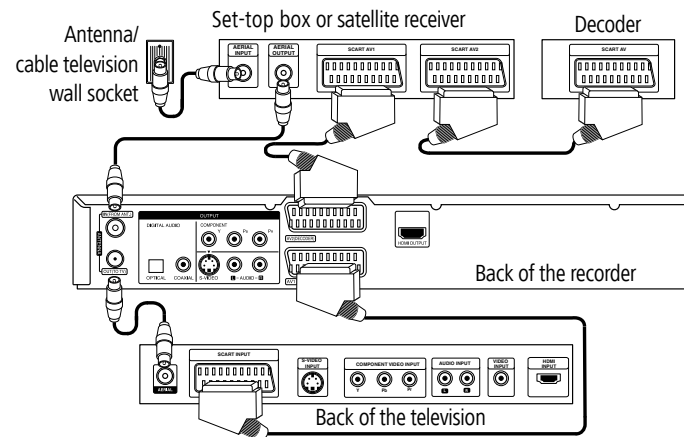

# Initial Installation

## Connecting to an Amplifier

### Connecting to an analog amplifier with analog 2-channel stereo or Dolby Pro Logic II / Pro Logic

Connect the left and right **AUDIO OUT** socket of the recorder to the left and right **AUDIO IN** sockets of the amplifier, receiver or stereo system with the audio cables (A).

### Connecting to a digital amplifier with two-channel digital stereo (PCM) or to an audio/video receiver with a multi-channel decoder (Dolby Digital™, MPEG 2 or DTS)

1. Connect one of the **DIGITAL AUDIO OUT** sockets (**OPTICAL O** or **COAXIAL X**) of the recorder to the appropriate input socket on your amplifier. Use an appropriate digital audio cable (optical **O** or coaxial **X** - available from your dealer).
2. You must configure the digital output of the recorder (page 29).

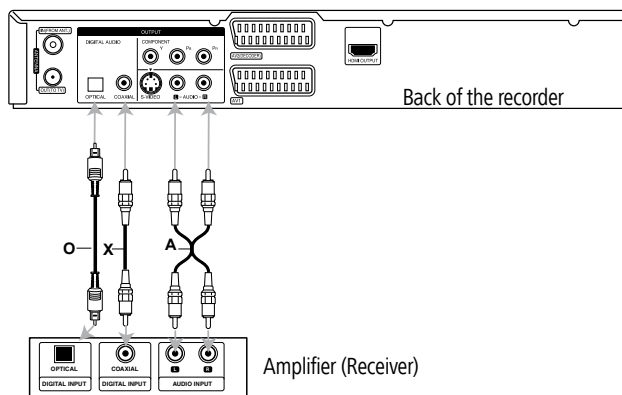

### Digital multi-channel sound

A digital multi-channel connection offers the best sound quality. You will need a multi-channel audio/video receiver which supports one or more audio formats, e.g. MPEG 2, Dolby Digital and DTS. You will find information in the documentation enclosed with the receiver.

- Due to the DTS licensing agreement the digital output will be to DTS **DIGITAL-OUT** when a DTS audio stream is selected.

This recorder does not perform a (2-channel) decoding (downmix) of a DTS sound track internally. In order to enjoy DTS multi-channel surround sound, you have to connect this recorder to a DTS-compatible receiver via one of the recorder's digital audio outputs.

- If the audio format of the digital output does not correspond to the capabilities of your receiver, the receiver will emit a strong distorted sound or no sound at all.

5.1 Digital surround sound via the digital connection can only be obtained if your receiver is equipped with a digital multi-channel decoder.

You can obtain information about the audio format of the current DVD via the "Disc Info" menu (page 35).

## Connecting Audio/Video (A/V) Accessories

Connect the input sockets (**AV2** on the back of the device or **AV3** = input on the front of the device (page 6)) of the recorder to the audio/video out sockets of the accessory components with the audio/video cables.

If you have connected a device to **AV2** and switched off its power supply, the Digital Link Plus function to the recorder is not possible.

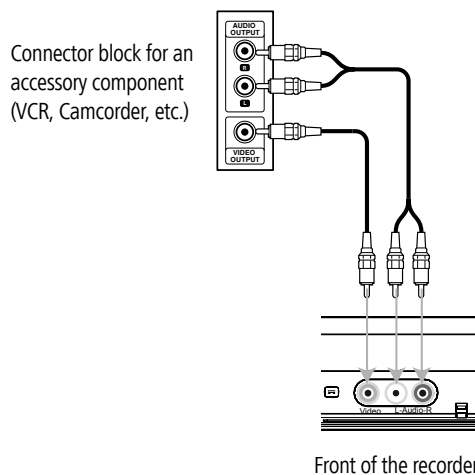

# Initial Installation

## Connecting a digital camcorder

You can connect a digital camcorder (DV) or a digital DVD-R/RW recorder to the **DV IN** socket and transfer contents of DV tapes or DVDs digitally.

Use a DV cable (not included in delivery) to connect the **DV IN-/OUT** socket of your DV-camcorder/video deck to the **DV IN** socket on the front control panel of this recorder.

- ➡ Only DV units can be connected to this socket (the source signal must be in the DV-25 format; see page 49). It is not compatible with digital satellite tuners or S-VHS video decks.

DV Digital Camcorder

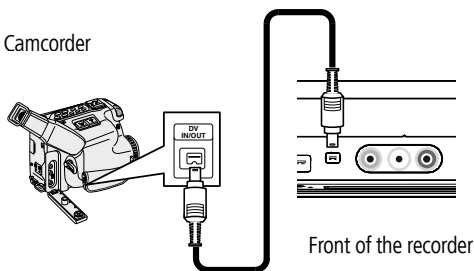

## Connect to the mains

First plug the small plug on the power cable into the mains connection on the back of the recorder then plug the large mains plug into a 110-240V/50-60Hz mains socket.

## Basic Settings

REC

Set the remote control for recorder operation.



Push the On/Off button on the DVD recorder or



the On/Off switch on the remote control.

- ➡ If you aim the remote control at the recorder when switching over to Recorder mode, the recorder will be switched on.

## Activating Digital Link

With Digital Link, Loewe TV sets pass on the signals from the remote control through the Euro-AV connection on the recorder. Digital Link is useful when you want to put the recorder in a concealed place, e.g. in a closed rack.

- ➡ Your recorder must be switched on.



Button **on the recorder** for > 3 s

Digital Link on: **LINK** appears in the recorder display.

Digital Link off: **FRONT** appears in the recorder display.

## Resetting the DVD Recorder

If any of the following problems occur.

- The unit is plugged in but will not turn on or off.
- The display panel does not work.
- The recorder is not working properly, no picture is displayed, the Recorder can be reset in the following way:



Hold down the button on the device for at least 10 seconds. The device switches off or pull out the power cable, wait at least 20 seconds and reconnect the cable.

Press the button again to switch the device back on.

# Initial Installation

## Auto Setup

After you have pressed the On/Off button or reset the device to the factory settings, the wizard for the automatic setting starts. This sets the language of the menus and dialogs of the recorder, the time and the stations.



▲ ▼ Select menu **Language**.

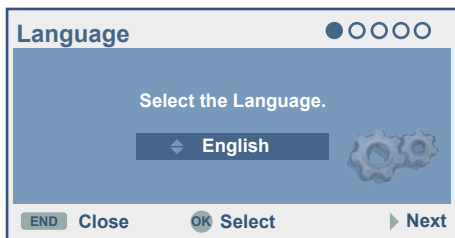

Confirm selection with **OK**.

Check the antenna connection as illustrated.

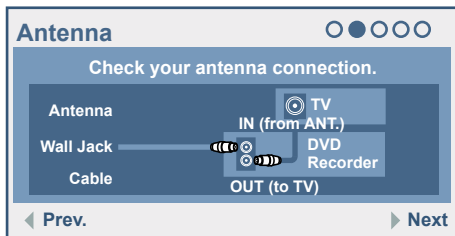

Continue with **OK**.



▲ ▼ Select **country**.

▶ Mark **Start**.

Start station search with **OK**.



The receiver runs through all the available channels automatically and transfers the found stations to the station list.



▲ ▼ Set time. Select **Auto** or **Manual**.

Confirm selection with **OK**.

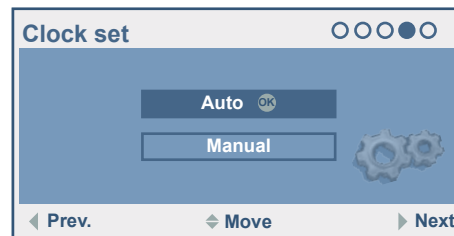

**Auto:** The current time and date are set automatically after the station search (see "Set time" on page 27).

**Manual:** Enter the date and time.

◀ ▶ Move cursor.

▲ ▼ Enter data.

Confirm with **OK**.

▶ Mark **Close**.

Confirm selection with **OK**.

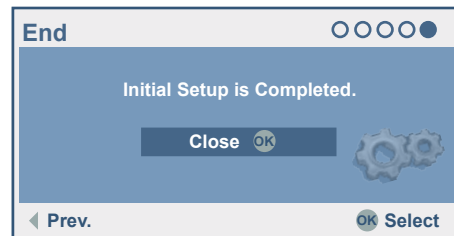

# Initial Installation

## Menu overview

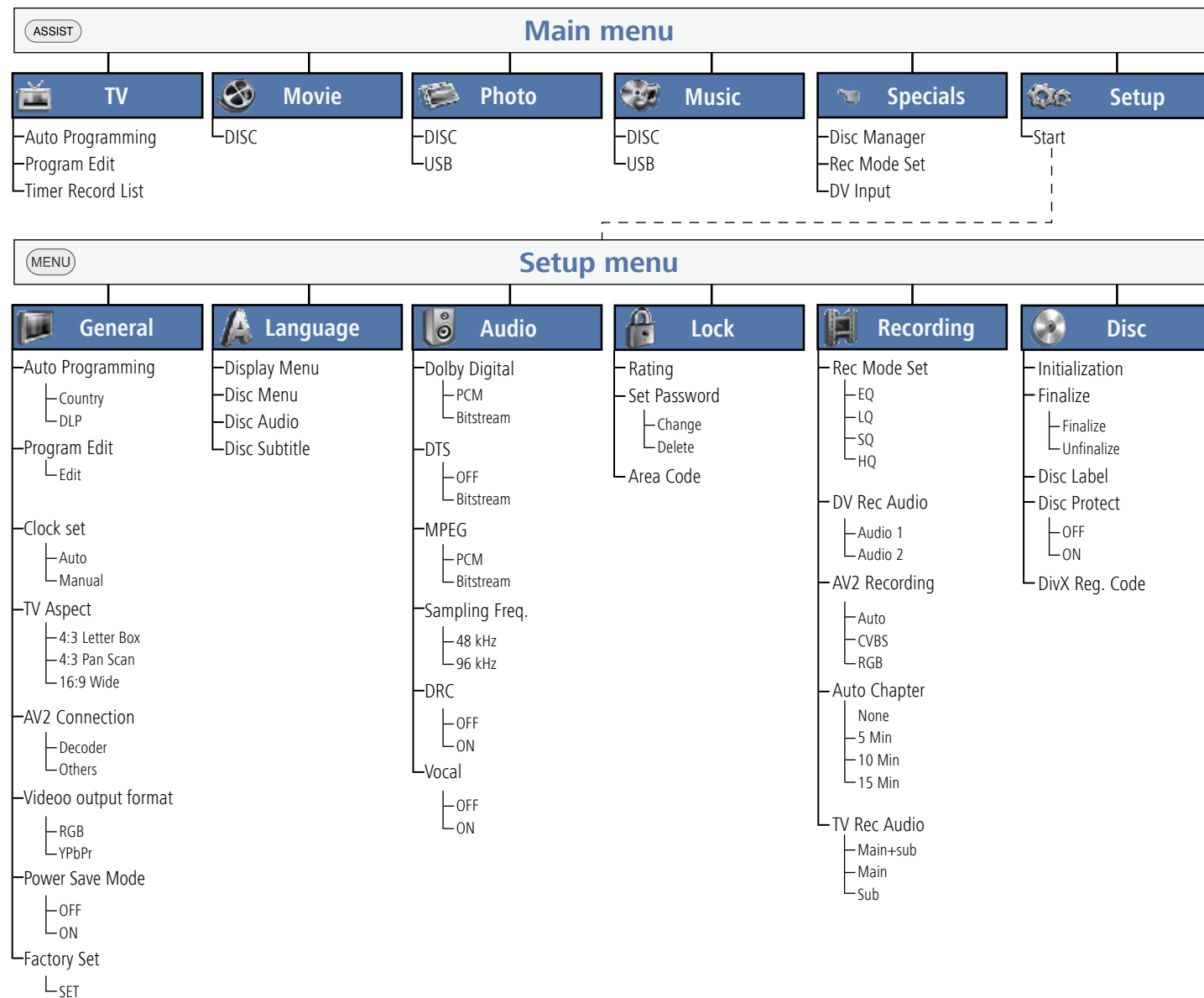

# Initial Installation

## Main menu (HOME)

All media files can be called from the main menu for playing and recording with the recorder.

ASSIST

Call main menu.

◀ ▶ Select desired operating mode.

▲ ▼ Call options.

Confirm selection with **OK**.

ASSIST

Exit main menu.

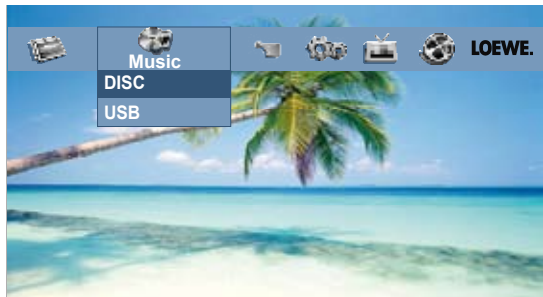

**TV Auto programming:** See page 24.

**Program Edit:** See page 25.

**Timer Record List:** See page 48

**MOVIE Disc:** a.) Display of **Title List** menu of a rewritable disc (page 51).

b.) Display of the **Movie List** menu of a DivX disc (page 41).

c.) Play a DVD-Video-Disc (page 37).

**PHOTO** (page 44)

**Disc:** Display the **Photo List** menu of the disc.

**USB:** Display the **Photo List** menu of the USB memory.

**MUSIC** (page 42)

**Disc:** Display the **Music Title List** (or Audio-CD) menu of a disc.

**USB:** Display the **Music Title List** menu of the USB memory.

**Specials Disc Manager:** Open the **Initialization** menu (page 32).

**Rec. Modes:** Open the **Rec Mode Set** menu (page 31).

**DV input:** Switch to the DV input (page 49).

**Setup** Start the **Setup** menu (this page).

## Setup menu

The menu system offers several ways of changing settings. Most menus consist of three levels for setting up options. If you press **(MENU)** only the first and second levels of the menu system are displayed on the screen. You can display the third level by pressing **▶**. When navigating in the menus, **▶** on the right side of the menu tab shows you that the next level can be called up.

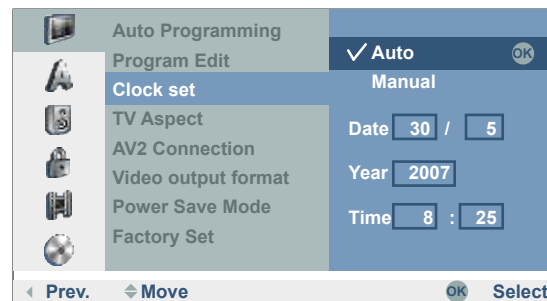

1st level

2nd level

3rd level

### Navigation in the menu

The arrow buttons of the Assist remote control are illustrated as follows in this user guide:



The arrows correspond in the text: "▲ ▼ ◀ ▶".

The OK function is shown in the text as **OK**.



Call menu.

▲ ▼ Select desired option.

▶ Call second level.

▲ ▼ Select second option.

▶ Call third level.

▲ ▼ or ▶ to select the desired setting.

Confirm selection with **OK**.



Exit menu.

# Initial Installation

## The General Menu



### Automatic programming

This recorder is equipped with an analog receiver (tuner) which can receive a maximum of 88 channels.

➤ When using Digital Link Plus, the channel setting is adapted to the TV set (on this page).

➤ Connect the recorder to the aerial system (page 16).



Call menu.

▲ ▼ Select **General** symbol.

▶ Call second level.

▲ ▼ Select **Auto Programming**.

▶ Mark country option.

▲ ▼ Select **Country**.

▶ Mark **Start**.

Start channel search.



The tuner runs through all the available channels automatically and transfers the found stations to the tuner memory.

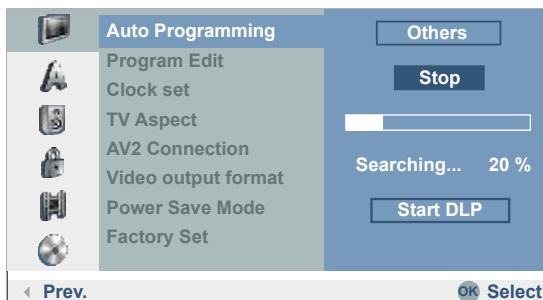

### Digital Link Plus

If you have connected the recorder to a Loewe TV set with Digital Link Plus or a comparable system of another make (e.g. EasyLink, Mega Logic, Project 50), the station list will be transferred from the TV to the recorder. This happens when you log in the recorder to the TV set or when you change the stations on the TV set (resort, delete, add others). After such a change, the TV will prompt you to start transfer of the changed station list.

The recorder detects a connected TV set with Digital Link Plus or the comparable system of a different make and sets the recorder accordingly. Then you can no longer search for, delete or sort TV stations on the recorder. The menu items are displayed in grey, in the automatic search it is only possible to transfer the station data from the TV set.

Please note that all stations which you receive via aerial or cable have to be stored at channel slots 1 to 88 in the TV set. If the TV set does not prompt you to transfer the station data, start the transmission on the recorder.

Please make all station changes only on the TV set if your TV set is equipped with Digital Link Plus or a comparable system of another make.

If your TV set to which you have connected the recorder does not have Digital Link Plus or a comparable system, you should match up the stations lists of the recorder and the TV set. This makes it easier for you to find the channels on the TV set and the recorder.

➤ Connect the recorder to the TV set with Digital Link Plus with a SCART connection (page 17).

➤ If the recorder has taken over the stations from a Loewe TV via Digital Link Plus (DLP), the functions **Program Edit**, **Move** and **Delete** are locked and cannot be used again until the channels have been overwritten again by automatic programming.

### Transfer station list



Call menu.

▲ ▼ Select **General** symbol.

▶ Call second level.

▲ ▼ Select **Auto Programming**.

▶ Press 3 times. The Start DLP button is marked.

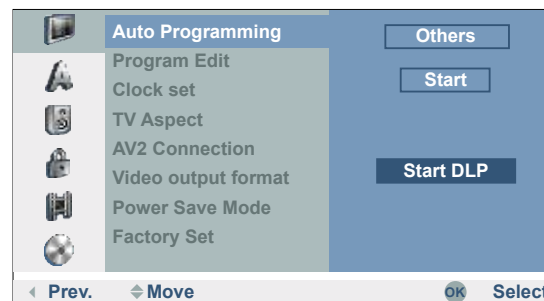

Start transfer of the station list from the TV to the recorder.

This may last a few seconds. The display on the recorder shows **DLP** during the transfer.

➤ (Viewvision Secam). French stations will only be transferred in the correct standard with Digital Link Plus if you select **France** as the country (see above) first.

# Initial Installation

## Program Edit

You can edit a channel manually (add, delete, rename, move etc.).



Call menu.

- ▲ ▼ Select **General** symbol.
- ▶ Call second level.
- ▲ ▼ Select **Program Edit**.
- ▶ Mark **Edit**.

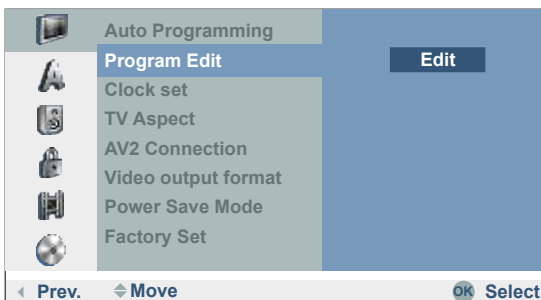

Confirm. The **Station List** menu is displayed.

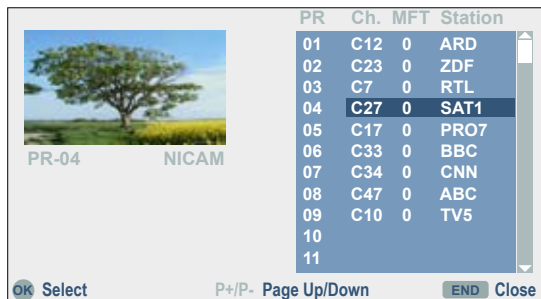

- ▲ ▼ Select **PR** number.

Confirm with **OK**.

The available options are displayed at the bottom left.

- ▲ ▼ Select option.

Confirm with **OK**.

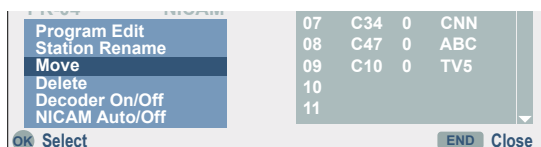

## Explanations of the settings

- Program Edit** search, channel input, fine adjustment
- Station Rename** Change name
- Move** Move station in the station list
- Delete** Delete station from the station list.
- Decoder On/Off** Divert station via decoder (**on**).
- NICAM Auto/Off** Switch off NICAM reception (**off**).



Close menu.

## Program Edit

In addition to the automatic programming, it is also possible to set and store stations manually.

Not with Digital Link Plus (DLP).



- ▲ ▼ Select station in the **Station List** menu.

Confirm. The **Station List** menu is displayed.

The available options are displayed at the bottom left.

- ▲ ▼ Select **Program Edit**.

Confirm with **OK**.

The **Program Edit** menu is displayed.

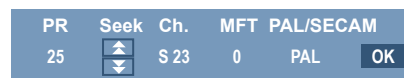

- ◀ ▶ Move the cursor to the previous / next column.

- ▲ ▼ Edit the setting at the current cursor position.

## Explanations of the settings

- PR** Indicates the selected station number (display only).
- Seek** Searches for stations automatically.
  - ◀ ▶ Select **Seek** and then
  - ▲ ▼ start. The search is stopped when the recorder receives a station.
- Ch.** Changes the channel number.
  - ◀ ▶ Select **Ch.** and then
  - ▲ ▼ set.
- MFT** Changes the frequency for manual fine tuning.
  - ◀ ▶ Select **MFT** and then
  - ▲ ▼ set.
- PAL/SECAM** Changes the reception standard in Viewvision Secam.
  - ◀ ▶ With distorted negative picture select **PAL/SECAM**
  - ▲ ▼ Select **SECAM** for the SECAM-L standard.

Confirm with **OK**.

# Initial Installation

## Station Rename

You can give whatever name you like to a station. Names should have a maximum of five characters.



▲ ▼ Select station in the **Station List** menu.

Confirm with **OK**.

The available options are displayed at the bottom left.

▲ ▼ Select **Station Rename**.

Confirm with **OK**. The **Keyboard** menu is displayed.



Enter a name for the station.

▲ ▼ ◀ ▶ Select character or function.

**OK** Insert character.

## Explanations of the settings

**English/Latin Capital** Switches the keyboard to capitals.

**English/Latin Small** Switches the keyboard to small letters.

**Symbol** Inserts the selected character at the cursor position (shaded grey for special characters).

**OK** Save setting and exit.

**Space** Inserts a space at the cursor.

**Delete** Deletes characters to the left of the cursor.

**Cancel** Reject setting and exit.

◀ ▶ Moves the marker in the selection.

Inserts a space at the cursor.

Deletes the characters to the right of the cursor.

Deletes the character to the left of the cursor.

**P+ / P-** Moves the cursor to the left or right.

Switches the keyboard back and forth between capitals, small letters and symbols.

Press the **OK** button at the end to confirm the settings and return to the **Station List** menu.

## Moving stations

You can sort the order of stations in the **Station List** menu.

⏏ Not with Digital Link Plus (DLP).



▲ ▼ Select station in the **Station List** menu.

Confirm with **OK**.

The available options are displayed at the bottom left.

▲ ▼ Select **Move**.

Confirm with **OK**.

▲ ▼ Select desired slot.

**OK** to go to the station list.

## Delete Station

You can delete a station in the **Station List** menu.

⏏ Not with Digital Link Plus (DLP).



▲ ▼ Select station in the **Station List** menu.

Confirm with **OK**.

The available options are displayed at the bottom left.

▲ ▼ Select **Delete**.

**OK** The station is deleted.

## Decoder on/off



▲ ▼ Select the station which you want to divert via the decoder.

Confirm with **OK**.

The available options are displayed at the bottom left.

▲ ▼ Select **Decoder on/off**.

Confirm with **OK**.

When you select **On**, **Decoder** (with Secam: **Canal+**) appears underneath the station shown in the small picture.

# Initial Installation

## NICAM

This recorder can receive HiFi sound broadcasts in NICAM-Stereo. However, distortions may occur under unfavourable reception conditions. Switch off the function in this case (**off**).



▲ ▼ Select station in the **Station List** menu.

Confirm with **OK**.

The available options are displayed at the bottom left.

▲ ▼ Select **NICAM Auto/Off** under station list.

Confirm with **OK**.

When you select **Auto**, **NICAM** appears underneath the station shown in the small picture.

## Clock set

When the automatic station search has finished, the date and time are set automatically (depending on the transmitting station), also when power is recovered. The **Auto** option must be set for this.

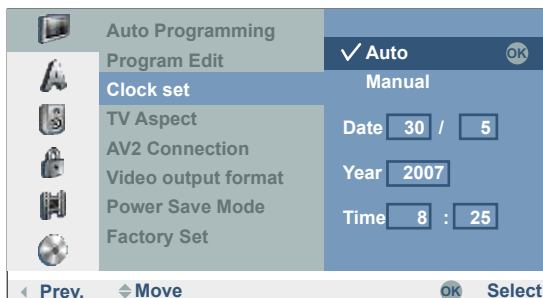

Call menu.

▲ ▼ Select **General** symbol.

▶ Call second level.

▲ ▼ Select **Clock set**.

▶ Call third level.

▲ ▼ Select **Auto**.

Confirm with **OK**.



Exit menu.

- ▶ Please check by pressing **INFO** in TV mode whether the year and date have been automatically set correctly. You may have to set it manually as described under "Manual setting of date / time".

## Manual Setting of the Date / Time

It is possible that the television station may broadcast incorrect date and / or time information or no information at all and that the Recorder sets the incorrect time. If this is the case we recommend that you set the clock manually.



Call menu.

▲ ▼ Select **General** symbol.

▶ Call second level.

▲ ▼ Select **Clock set**.

▶ Call third level.

▲ ▼ Select **Manual**.

Confirm with **OK**.

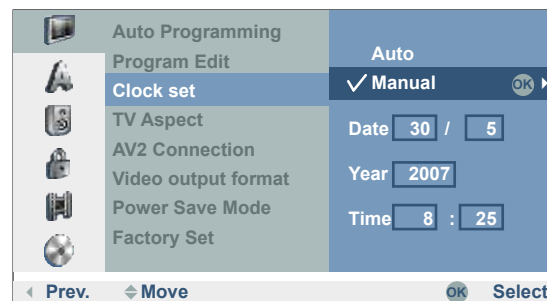

Enter the date and time.

◀ ▶ Move cursor.

▲ ▼ Enter data.

Confirm with **OK**.



Exit menu.

## TV Aspect

You can choose:

- 4:3 Letter Box** Recordings in wide-screen format appear with a black bar at the top and bottom edges of the screen.
- 4:3 Pan Scan** The picture fills the whole screen but cuts off sections at both sides if necessary.
- 16:9 Wide** Select this setting if a wide-screen TV set with 16:9 picture format is connected.

- ▶ If the resolution is set to 720p or 1080i, this option is not available.

# Initial Installation

## AV2 Connection

You can connect the following devices to the **AV2 DECODER** connection on the back of the recorder:

**Decoder** Connect a Pay-TV or Canal+ decoder.

**Other Device** Connect a video recorder or similar device.

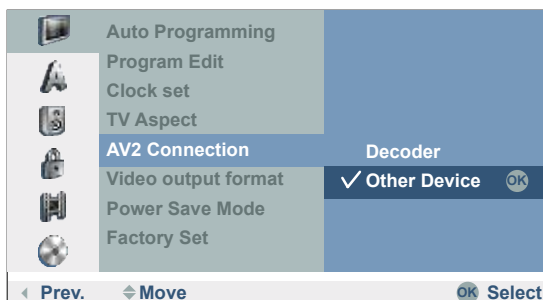

## Video output format

Select the video output format depending on which video interface you are using (page 16):

**YPbPr** The TV set is connected to the **COMPONENT VIDEO OUT** socket.

**RGB** The TV set is connected to the Scart socket **AV1 AUDIO/VIDEO**.

## Power Save Mode

You can set the recorder so that it consumes < 1 Watt on standby. In the **On** position, the decoder signal is switched from AV2 to AV1 and the display switched off.

## Factory Set

You can reset the recorder to its factory settings if necessary. Select **Set** and press **OK**. The Auto Setup menu appears (page 21).

- Some options cannot be reset with this (security stage, password, country code, station list, timer list).

# Language Menu



## Menu language

Select a language for the menus and dialogues displayed by the recorder.

**MENU**

Call menu.

▲ ▼ Select symbol **A** **Language**.

▶ Call second level.

▲ ▼ Select **Display Menu**.

▶ Call third level.

▲ ▼ Select **English**.

Confirm with **OK**.



## Disc languages

Select a language for the disc's menu, audio and subtitles.

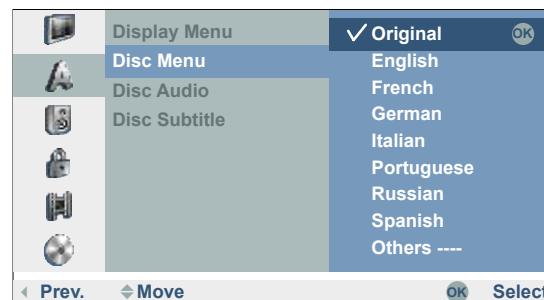

If another language is to be used as the "original" version of the disc, select this here if it is available on the Disc.

**Original** The original language of the disc is selected.

**Others** Select other language with **Other** and confirm with **OK**. Enter the corresponding four-digit number from the "language code list" on page 62 and confirm with **OK**.

**Off** Switch off disc subtitles.

# Initial Installation

## Audio Menu



Each DVD disc offers a variety of audio formats. Set the audio format for the recorder according to the type of audio system you are using.

### Dolby Digital / DTS / MPEG

**PCM** Select this option if the unit is connected to a digital two channel stereo amplifier. The DVD recorder's digital audio outputs emit sound in PCM 2 channel format if you play a DVD-Video disc with Dolby Digital audio format.

**Bitstream** Select "Bitstream" if you have a Dolby Digital decoder (or amplifier, a Loewe TV with AC3 or DIS module or another unit with Dolby Digital decoder) connected to the **DIGITAL AUDIO** socket of the DVD recorder.

**OFF** If you select "Off" the DTS signal is not emitted from the **DIGITAL AUDIO** socket.

### Sampling Frequency

If your receiver or amplifier is NOT designed for 96 kHz signals, select 48 kHz. If you have made this selection, the unit automatically converts the 96 kHz signals to 48 kHz signals that the system can decode. If your receiver or amplifier is designed for 96 kHz signals, select 96 kHz.

### Night Mode

Thanks to digital audio technology the DVD format enables you to hear soundtracks in the most accurate and realistic way possible. However, you may wish to limit the dynamics (i.e. the difference between the loudest and the quietest sounds). In this way you can play a film with minimum volume differences. For this purpose switch DRC to **ON**.

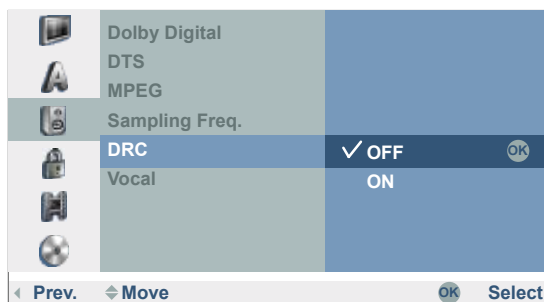

### Karaoke Audio

Switch the singing option (**Vocal**) on, if you want to play a multi-channel karaoke DVD. The karaoke channels on the disc are mixed into normal stereo sound.

## Lock Menu



Films on DVD can contain scenes that are not suitable for children. For this reason discs can contain child protection information that applies to the whole disc or only to certain scenes on the disc. The ratings are country-dependent. The child lock function enables you to prevent your children watching certain discs or scenes.

### Set Password

Change the four-digit code.

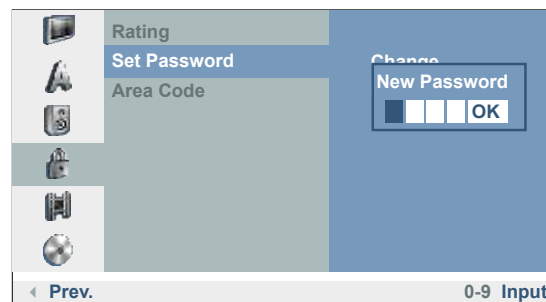

Call menu.

▲ ▼ Select symbol **Lock**.

▶ Call second level.

▲ ▼ Select **Set Password**.

▶ Call third level.

### If you have not yet entered a password

Enter a four-digit number with **number buttons**.

Confirm with **OK**.

Enter password to check.

Confirm with **OK**.

### If you have already entered a password

Select **Change**.

Confirm with **OK**.

Enter current password.

Confirm with **OK**.

Then enter a new four-digit password.

Confirm with **OK**.



# Initial Installation

Enter password to check.

Confirm with **OK**.

► If you make a mistake, press ◀ repeatedly before you press **OK** to delete or correct the password numbers one after another.

## Switching off the password

Proceed as follows if you want to switch off the password.



Call menu.



▲ ▼ Select symbol **Lock**.

▶ Call second level.

▲ ▼ Select **Set Password**.

▶ Call third level.

▲ ▼ Select **Delete**.

Confirm with **OK**.



Enter a four-digit number with **number buttons**.

Confirm with **OK**.

## Delete Password

If you forget your password, proceed as follows to delete the current password.



Call menu.



Enter the six-digit number "210499" with the **number buttons**.

A message is displayed.



◀ ▶ Select the **yes** button.

Confirm with **OK**.

The four-digit password is deleted. Enter a new password as described above.

## Rating

This function prevents playing of DVDs unsuitable for children if these contain the appropriate code.



Call menu.



▲ ▼ Select symbol **Lock**.

▶ Call second level.

▲ ▼ Select **Rating**.

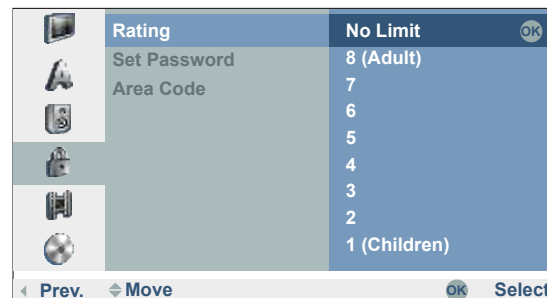

▶ Call third level.

Enter the four-digit password with the **number buttons** (see **Set Password**).

Confirm with **OK**.

▲ ▼ Select security stage between 1 and 8.

**No Limit** If you select "No Limit", the parental lock is not active. The disc will be played fully.

**Step 1 to 8** Some discs contain scenes which are unsuitable for children. If you assign the recorder a security stage, only those scenes of the inserted disc will be played which correspond to the assigned security stage or have a security stage below it.

"1" has the most play restrictions.

"8" has the least play restrictions.

Scenes with a higher rating on the DVD are only played when appropriate substitute scenes are available on the disc. The alternative scene must have the same or a lower security stage. If no suitable alternative is found, the recorder stops playing. You have to enter the four-digit password or change the rating to play the disc.

Confirm with **OK**.



# Initial Installation

## Area Code

Enter the code for a country/region whose standards are to be used to rate the DVD-Video disc. (See "List of country code" on page 63). For Great Britain select "G B".

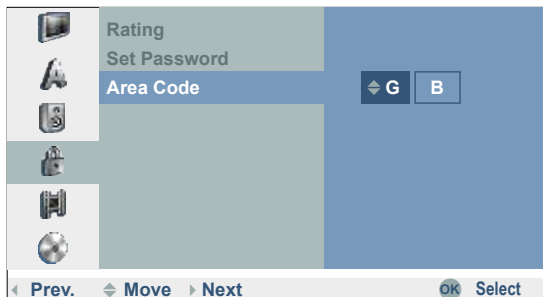

MENU

Call menu.



▲ ▼ Select symbol **Lock**.

▶ Call second level.

▲ ▼ Select **Area Code**.

▶ Call third level.



Enter the four-digit password with the **number buttons** (see "Set Password").

Confirm with **OK**.

▲ ▼ Enter data.

◀ ▶ Move cursor.

Confirm with **OK**.

## Recording Menu



### Rec Mode Set

You can set the picture quality for recording:

|                            |          |                 |
|----------------------------|----------|-----------------|
| <b>DVD+/-R/RW (4,7 GB)</b> | HQ mode: | approx. 1 hour. |
|                            | SQ mode: | 2 hours.        |
|                            | LQ mode: | 4 hours.        |
|                            | EQ mode: | 6 hours.        |

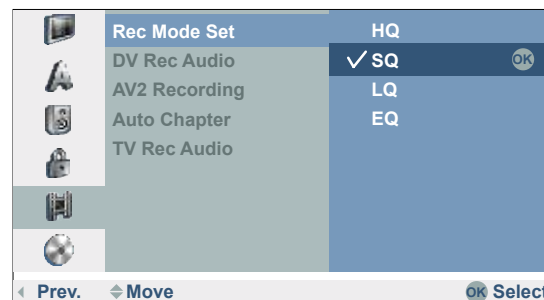

MENU

Call menu.

▲ ▼ Select symbol **Record**.

▶ Call second level.

▲ ▼ Select **Rec Mode Set**.

▶ Call third level.

▲ ▼ Set desired recording quality (EQ, LQ, SQ or HQ).

Confirm with **OK**.



# Initial Installation

## DV Rec Audio

You need to use this setting if your camcorder with 32 KHz / 12-bit is connected to the **DV IN** socket on the front panel. Some digital camcorders have two stereo tracks for audio. One is used for recording, the other is used for post-editing. On the **Audio 1** setting the original sound is recorded. On the **Audio 2** setting the edited sound is used.

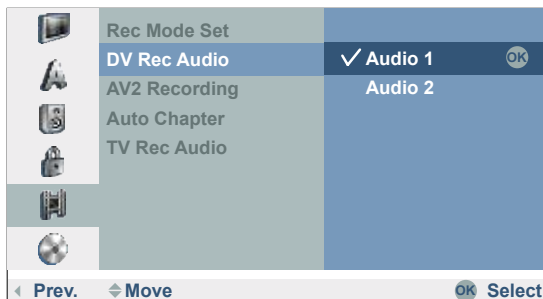

## AV2 Recording

The signal type can be selected to record the video in signal of a device connected to the **AV2 DECODER**.

- Auto** The video in signal is adapted automatically to the received video signal.
- CVBS** Only for recording a CVBS input signal.
- RGB** Only for recording an RGB input signal.

## Auto Chapter

Chapter start marks are inserted at fixed intervals in recordings on DVDs in video mode. Intervals of 5, 10 or 15 minutes are possible. If you select **None** automatic chapter setting is switched off.

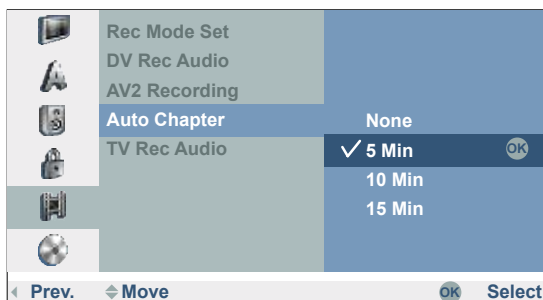

## TV Rec Audio

When recording bilingual TV you can select the audio channel to be recorded.

- Main+sub:** both languages are recorded.
- Main:** language 1 only.
- sub:** language 2 only.

# Disc Menu



## Initialization

A new disc is initialised by the recorder (on request) when inserted.

- DVD-R** The recorder initializes the disc in "video mode".
- DVD-RW** The recorder initializes the disc in "video mode".
- DVD+R** The recorder initializes the disc in "VR mode".
- DVD+RW** The recorder initializes the disc in "VR mode".

☛ A *DVD+RW* or *DVD-RW* disc can also be initialised later by menu:

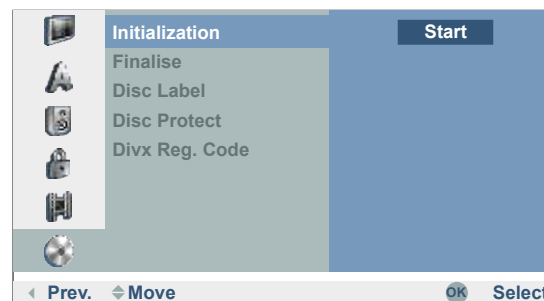

Call menu.



▲ ▼ Select symbol  **Disc**.

▶ Call second level.

▲ ▼ Select **Initialization**.

▶ Call third level.

**OK** call **Start** menu.

◀ ▶ Select a desired format for DVD-RW (**Video mode** or **VR mode**).

Confirm with **OK**.

# Initial Installation

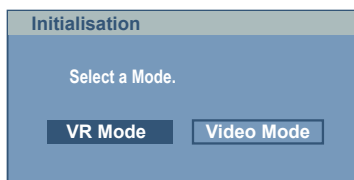

The following prompt appears:

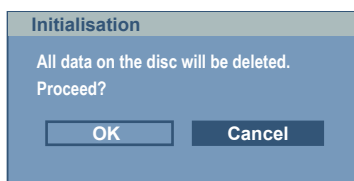

◀ ▶ Select **OK** button.

Confirm with **OK**.

▣ When you start formatting all recordings on the disc are deleted.

After pressing **OK** disc formatting begins. It can take a few minutes.

## Finalisation

Finalisation fixes recordings so that the disc can be played on a regular DVD player or a computer with a suitable DVD-ROM drive. During finalisation of a Video mode disc a menu is created for disc navigation (page 58).

▣ Following recording and finalisation of DVD-R and DVD+R discs no other editing or recording can take place. This does not however apply for a DVD+RW and DVD-RW disc.



(MENU)

Call menu.



▲ ▼ Select symbol  **Disc**.

▶ Call second level.

▲ ▼ Select **Finalise**.

▶ Call third level.

▲ ▼ Select **Finalise**.

Confirm with **OK**.

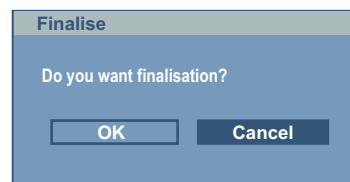

◀ ▶ Select **OK** button.

Confirm with **OK** to finalise the disc.

▣ The time needed for finalisation depends on the type of disc, how much is recorded on the disc and the number of titles on the disc. Finalisation of a prerecorded disc can take up to 8 minutes.

▣ When inserting a finalised DVD-RW, the finalisation can be cancelled by selecting **Unfinalise** in the **Finalise** menu. Then the disc can be edited and rewritten.

## Disc Label

Use this option to enter a name for the disc. The name is displayed when the disc is loaded and when you display disc information on the screen.

▣ The disc name can be up to 32 characters long.

▣ For discs formatted on other recorders you will only see a limited character set.

(MENU)

Call menu.



▲ ▼ Select symbol  **Disc**.

▶ Call second level.

▲ ▼ Select **Disc Label**.

▶ Call third level **Edit**.

Confirm with **OK**.

# Initial Installation



Enter a name for the disc.

▲ ▼ ◀ ▶ Select character or function.

**OK** Insert character.

See **Station Rename** on page 20 for functions.

Save with **OK** button.

## Disc Protect

Set Disc Protect to **On** to avoid accidental recording, editing or deleting of the disc. To release the disc again, select **OFF**.



## DivX registration code

You receive the DivX® VOD (Video On Demand) registration identification for hiring and purchasing films through the DivX® VOD-Service. Further information is available under:  
[www.divx.com/vod](http://www.divx.com/vod).



Call menu.



▲ ▼ Select symbol  **Disc**.

▶ Call second level.

▲ ▼ Select **Divx Reg. Code**.

▶ Call **View**.

Confirm with **OK**.

The "registration code" valid for your device is now displayed.

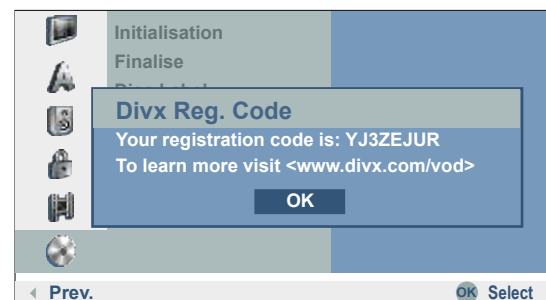

You can use this registration code to hire or buy movies through the DivX® VOD Service under [www.divx.com/vod](http://www.divx.com/vod).

See the instructions for saving movies on a disc for playing on this recorder.

► All movies purchased from DivX® VOD can be played only on this recorder.

# Operating convenience

## Additional Screen Menus

This manual contains basic instructions for operating the recorder. Some DVDs require specific handling or only permit limited operation during playback. If this is the case the  symbol appears on the screen. This indicates that certain operations are not permitted at certain points or that no menu is available on the disc.

### The Disc Info menu

If you are currently watching a TV channel supplied by the integrated receiver of the recorder (recorder in Stop mode), you can show (and hide) information about the TV station and the inserted disc with **OK** or .

Example: A DVD-RW in the VR mode is inserted and the station **01** with the name "Kabel" is on at the moment:

Indicates the channel number, the station name and the audio signal (NICAM, STEREO, MONO, BILINGUAL) of the station you are currently watching.

Indicates in a progress bar the ratio of used to free space on the inserted disc, the free space in hours (H) and minutes (M) and the recording quality.

Indicates the name, mode and format of the disc.

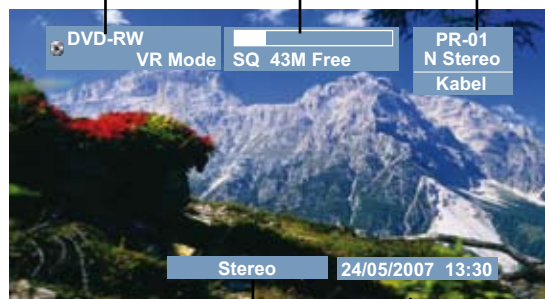

Indicates the current sound format.

Indicates the current date and time.

## Temporarily Visible Symbols

 Resume play from this point.

 Action prohibited or not available.

 Not all discs provide all the functions described below.



 The screen menu closes automatically when no buttons are pressed for 10 seconds.

## Displays of disc information in the title menu during disc playback

You can display different information about the inserted disc on the screen and make settings.

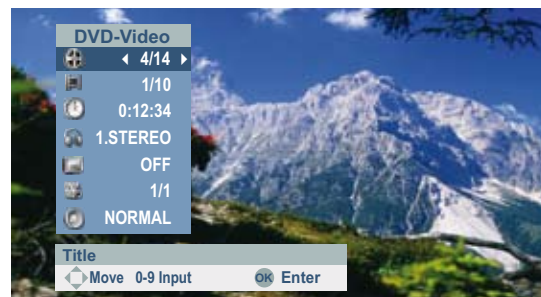
 Twice to select the Title menu.



  Select the desired function.

- Title** Current title (or track number)/total number of titles (page 37).
- Chapter** Current chapter number/total number of chapters (page 37).
- Time** Elapsed playing time (page 38).
- Sound** Selected sound formats, movie language and audio channels (page 33).
- Subtitles** Selected subtitle (page 40).
- Camera** Selected camera position / total number of camera positions (page 39).
- Sound** (3D-surround) selected sound mode (page 39).

 Exit menu.

# HDMI mode

## HDMI (DVI) connection

The HDMI connection (High Definiton Multimedia Interface) allows digital picture and sound transmission via a connecting cable, e.g. to Loewe Flat TV sets. The digital picture and sound data are transmitted without data compression and therefore lose none of their quality. In the equipment connected, no analogue/digital conversion is necessary, which might also have lead to losses in quality. DVI signals can be also be reproduced by the HDMI connection using a DVI/HDMI adapter cable. This is possible because HDMI is based on DVI and is downwardly compatible. That means that the digital video signals are transmitted via HDMI - no audio signals are transmitted, though. In addition, both use the same copy protection method HDCP (High-bandwidth Digital Content Protection).



Switch off the TV set/monitor with HDMI connection and recorder.

Connect recorder to TV set/monitor via HDMI connection as described on page 16/17.



Switch on the TV set/monitor.



Switch on the recorder after 30 seconds.

Log in the HDMI connection in the connection wizard of the TV set (see user guide TV set).

► DVI: If a DVI-HDMI adapter cable is used for transmission, connect the analog or digital audio outputs on the recorder with the corresponding inputs of the TV set as described on pages 16 - 19.

Leave the existing SCART connection as it is to record from the TV.

## HDMI operation



Switch the TV set over to the HDMI AV input (takes place automatically in connection with a -Loewe Flat-TV set, see page 16).



Press the **RES** button on the recorder repeatedly to set the desired picture resolution (e.g. **576i**, **576p**, **720p**, **1080i**).

► You can only set resolutions which your TV set/monitor is capable of. For optimum picture quality, select the resolution **1080i** on the recorder.



Open the disk drawer.

Insert the selected disk in the drawer with the side to be played facing down.

Close the drawer.



Depending on the medium, playing starts automatically or is started with the Play button or you have to make entries in the menu.

- At a set resolution of 720p or 1080i, the other sockets (VIDEO OUT, S-Video and Component Video) have no function.
- If your TV set is unable to process a sampling frequency of 96kHz, set the sampling rate to 48 kHz in the Setup menu under "Sound" (page 29). If you have selected this option, the recorder will automatically convert all 96kHz signals to 48kHz-signals.
- This recorder performs no internal (2-channel) decoding of DTS soundtracks. In order to enjoy DTS multi-channel surround sound, this recorder must be connected by one of the digital audio outputs to a DTS-compatible receiver.
- If the "Dolby Digital" or "MPEG" option has not been set to "PCM" in the Sound menu (page 29), no sound is output through the TV set.
- The HDMI connection to the recorder is operated as a signal output. Please proceed as described on page 49 if you want to record from an external signal source with the recorder.

# Video mode

## Playing back a DVD

### Preparation

Switch the television on and set the video source to be the input that the recorder has been connected to or activate the "Control voltage" option for the television's AV input.

➡ This is unnecessary in Loewe Flat TV sets.

If you have connected the recorder to an audio system, switch on the audio system and, as the source, set the input that the DVD recorder has been connected to.



Open the disc drawer.

Insert the selected disc in the drawer with the side to be played facing down.

Close the drawer.

**READING** shows on the display while disc recognition is in progress.

### Play

After detection of the disc it starts playing automatically or a disc menu is displayed.



▲ ▼ ◀ ▶ Select title on DVD.

▶ Start / continue playing.

The menu setting and the exact operating instructions for the disc may differ from disc to disc. Follow the instructions on the individual menu pages.



**Pause:** Pause playing.



**Stop:** Finish playing.

You will find further information on page 35.

➡ If the child lock is active and the DVD disc's security rating is higher than that of the child lock, the four-digit password will need to be entered (see "Ratings" on page 30).

➡ DVD's have a country code. The recorder will not play a disc that has a country code which differs from the country code stored in the unit. This player has country code 2.

## General functions

➡ Unless otherwise indicated, the remote control (page 3) is able to control the functions described. The recorder's own controls can also be used to control certain functions (page 6).

### Select TITLE DVD-ALL DivX



Twice to select the Title menu.



▲ ▼ Select  symbol.

◀ ▶ Select title number.

**OK** start playing.

### Select CHAPTER / TRACK

DVD-ALL

If a title has several chapters/tracks, you can select another chapter/track as follows:



**P+** or **P-** during playing to select the next chapter/next track or return to the beginning of the current chapter/track.

**P-** twice briefly to return to the previous chapter/track.

### Search DVD-ALL DivX CD

Select the search direction and speed:



Press several times for faster search in reverse.



Press several times for faster search forwards.

Speed and direction are shown as arrows.



End search mode and continue playing.

### Skip



Jump forward 30 seconds during playing (DVD±R, DVD±RW).

# Video mode

## Freeze frame and picture for picture play-back

DVD-ALL DivX



**Pause:** Pause playing.



◀ ▶ Scroll picture by picture.



Continue playing.

⇒ The picture by picture scroll back is not supported in DivX.  
You can page forward through images by pressing **PAUSE** on the remote control.

## Slow Motion

DVD-ALL



**Pause:** Pause playing.



Switch on slow motion mode during pause.

Select the slow motion direction and speed:



1/16, 1/8, 1/4, 1/2 (reverse).



1/16, 1/8, 1/4, 1/2 (forwards).

Slow motion speed and direction are displayed.



End slow motion mode and continue playing.

## Repeat DVD-ALL CD MP3

### DVD-Discs



Select type of repetition.

**A-B** Repeats the position marked with **OK**.

**Chapter** Repeats the current chapter.

**Title** Repeats the current title.

**All** Repeats all titles on the disc (DVD-VR disc).

**Off** No repeat.

### DivX



Select type of repetition.

**Track** Repeats the current track.

**All** Repeats all tracks on the disc or in the folder.

**Off** No repeat.

## Time (Play from ...) DVD-ALL DivX

The "Time" function enables you to select where a disc starts playing.



Press twice.

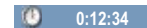

The elapsed playing time of the current disc is displayed in the "Time" box.



▲ ▼ Select  symbol.



Enter time in format h:mm:ss.

**OK** start playing from set time.

## Zoom DVD-ALL

With the Zoom function you can enlarge the video picture during playback and navigate in the enlarged picture.



Select Zoom function during play/freeze frame.

Zoom stages: x1, x2, x4, x1 (normal size).

◀ ▶ ▲ ▼ Select picture section.



Close Zoom window.

⇒ The Zoom function may not work on certain DVDs.

## Markers DVD-ALL

You can start playing from a saved marker. A maximum of six markers may be saved.



### Set Marker

Press the blue button briefly to set a mark at a selected point.

The marker symbol is displayed on the screen for a short time.



Repeat this step to enter a maximum six markers on one disc.

### Call Marker



Press the blue button long to select **Marker Search** menu.



▲ ▼ ◀ ▶ Select marked scene.

**OK** Start playing from marked scene.

# Video mode

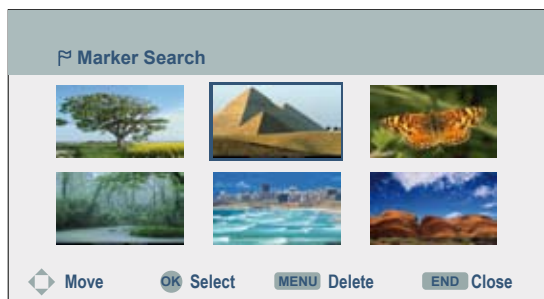

## Delete Marker

Press the blue button long to select **Marker Search** menu.



▲ ▼ ◀ ▶ Select marked scene.



Delete Marker.

◀ ▶ Select **yes** option.

Confirm with **OK**.



Exit the Marker Search menu.

➡ The markers are only saved until the disc is changed (*DVD-ALL*).

## Disc menu *DVD-V*

DVDs usually contain their own menus.



Select **Disc menu**.



▲ ▼ ◀ ▶ Select the desired settings.

Confirm with **OK**.



Exit **Disc menu** *DVD*.

## Camera positions *DVD-V*

If the DVD contains scenes taken at different camera positions, it is possible to change to another camera position during play-back.



Select twice during play-back.

▲ ▼ Select symbol.



◀ ▶ Select the desired camera angle. The number of the current camera position is displayed.



➡ A camera symbol will appear on the screen during scenes that were recorded using different camera positions.

## Digital sound formats, movie language and audio channels

You can select the digital sound format in connection with the movie language here.



Select twice during play-back.



▲ ▼ Select symbol.



◀ ▶ Select other movie language or sound format (*DVD-V DivX*).

➡ Some discs have got Dolby Digital and DTS sound tracks. If DTS is selected, there is no analogue audio output. To listen to the DTS sound track, connect the recorder via one of the digital outputs to a DTS amplifier (page 19).

## 3D-Surround *DVD-ALL DivX*

This device can create a 3D surround effect which simulates a multi-channel audio reproduction with two conventional stereo speakers.



Select twice during play-back.



▲ ▼ Select symbol.







◀ ▶ Select **3D SUR.** for surround sound.



◀ ▶ **NORMAL** to end surround sound.

# Video mode

## Subtitles *DVD-ALL DivX*

-  Select twice during play-back.
-  ▲ ▼ Select  symbol.
-  OFF
- ◀ ▶ Select the desired subtitle language.

## Playing discs or USB devices with mixed contents

If the memory media contain files of different playing formats such as MP3, JPG and DivX, you can switch between the three play modes **MOVIE**, **PHOTO** and **MUSIC** with the button  or  in the main menu (page 23):

- ▶▶▶ For operation of the **MOVIE** mode, see chapter “DivX mode” on page 35 (not for USB memory media).
- ▶▶▶ For operation of the **MUSIC** mode, see chapter “Audio mode” on page 36.
- ▶▶▶ For operation of the **PHOTO** mode, see chapter “Photo mode” on page 38.

## Storing the last disc settings

### *DVD-V Video VR*











The recorder saves the user settings for the last disc that you have watched. The settings are saved until you remove the disc from the recorder or switch it off. If you insert a disc that has already been played back, playback will continue from the last stopping point.

## PIP (Picture In Picture)

### *DVD-ALL*

This function enables you to watch TV stations or videos from other connected AV sources whilst playing the video.



-  Start play-back.
-  Switch on small picture.
-  Select station for small picture in TV mode.
-  Select signal source for the small picture in the order Tuner, AV1, AV2, AV3, DV, Tuner.
-  End play-back and PIP. Transfer small picture to large picture.
-  ◀ ▶ Select desired small picture position.
-    **Yellow button** – Select Zoom function for the small picture. Three different sizes are available.
-  Switch off small picture.

# DivX mode

With this recorder you can play DivX files which are saved on CD-R/RW or DVD±R/RW media.

➡ Before playing DivX files, please read the notes "About DivX Video files" on this page.

## Playing DivX files



Open the disk drawer.

Insert the selected disk in the drawer with the side to be played facing down.

Close the drawer. The disk is read.

The **Movie List** menu appears on the screen.

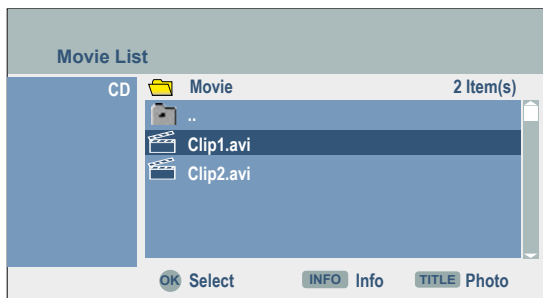

▲ ▼ Select title or folder.

**OK** show menu options for file.

▲ ▼ Select option.

Confirm with **OK**.



Start play-back.



**P+** or **P-** during play-back to select the next title or return to the beginning of the current title.

**P-** twice briefly to return to the previous title.



Finish playing.



Show detailed information.







Exit DivX menu.

See page 37 onwards for other operating functions.

## DivX subtitles

For subtitles to be displayed correctly press **MENU – LANGUAGE – Disk Subtitles** and select the desired subtitle language.

To select the correct character set for the subtitles, press the red button     during play-back and then select the desired character set with ◀ ▶.

The subtitles function can be switched on and off like on DVD Video (page 40).

## About DivX Video files

This recorder is compatible with the following DivX formats:

- The maximum picture resolution of the DivX file is less than or equal 720 x 576 (H x V) pixels.
- The filename of the DivX file has a maximum of 47 characters.
- Characters in DivX filenames which cannot be displayed are shown as “\_”.
- The unit can not correctly play image refresh rates of > 30 images per second.
- If the sound and picture are out of sync, either the sound or the picture is played.
- This recorder does not support the “GMC” DivX/Xvid function.
- Valid DivX file extensions for videos are: “.avi”, “.divx”.
- Valid DivX file extensions for subtitles are: “.smi”, “.srt”, “.sub” (only Micro DVD, Subviewer 1-2 formats), “.txt” (only Micro DVD, T1-4 formats). Other subtitles cannot be displayed.
- Valid DivX Codec formats: “DivX3.xx”, “DivX4. xx”, “DivX5.xx”, “XVID”, “3IVX”.
- Valid DivX Audio formats: “Dolby Digital” (AC3), “PCM”, “MP2”, “MP3”, “DTS (only at COAXIAL or OPTICAL)”, “WMA”.
- MP3 sampling rates: 8 - 48 kHz.
- WMA sampling rates: 32 - 48 kHz.
- MP3 bit rates: 32 - 320 kbps.
- WMA bit rates: 32 - 192 kbps.

# Audio mode

## Playing titles on Audio CD or MP3/WMA media

Audio CDs can be played with the recorder. Recordings in MP3/WMA format can also be played from USB memory medium, CD-ROM, CD-R or CD-RW discs (read the instructions for MP3/WMA recordings on page 43 before playing MP3/WMA recordings).



Open the disc drawer.

Insert the selected disc in the drawer with the side to be played facing down.

Close the drawer.

ASSIST

Call main menu.

◀ ▶ Select **Music**.

▲ ▼ Select **DISC / USB**.

Confirm selection with **OK**. The **Music List** menu appears on the screen.

AUDIO CD menu

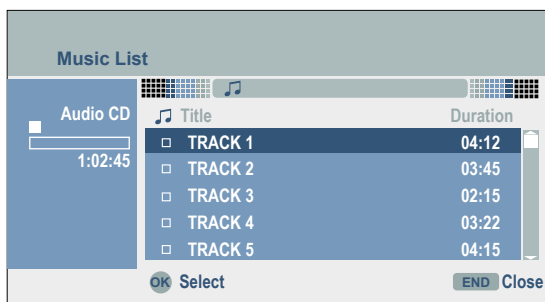

MP3/WMA menu

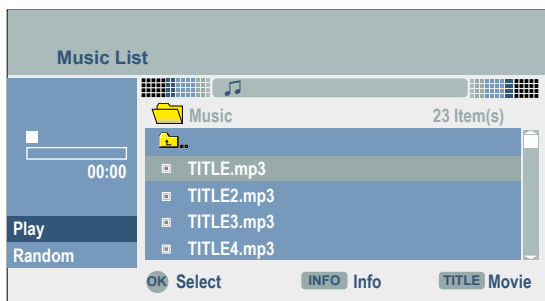

▲ ▼ Select title.



Start **Play**.

The elapsed playing time of the current track/current file is displayed on the left.

Playing stops automatically at the end of the disc/list.



Display detailed information (only MP3/WMA).



Finish playing.

## Options in the music menus



▲ ▼ Select title or folder.

**OK** display menu options.

▲ ▼ Select option.

Confirm with **OK**.

- Play** Starts playing the selected tracks/files.
- Random** Random play-back order of the tracks/files.
- Open** Open folder and show contents.

## Pause



Pause playing.



Continue playing.

## Play another title



**P+** or **P-** during play-back to select the next title or return to the beginning of the current title.

**P-** twice briefly to return to the previous title.

Enter the track number of the desired title directly with an Audio-CD.

## Search CD



Switch on seek mode during play-back.

Select the search direction and speed:



x2, x4, x8 (reverse).



x2, x4, x8 (forwards).

Search speed and direction are displayed.



End search mode and continue playing.

# Audio mode

## Random play



▲ ▼ Select title or folder.

OK display menu options.

▲ ▼ Select **Random**.

Confirm with **OK**. The random play-back starts and the symbol is displayed: **Random**.

Skip the current title with **P+**.

## Hints for MP3/WMA recordings

- Sampling rates: MP3: 8 - 48 kHz; WMA: 24 - 32 kHz.
- MP3 bit rates: 32 - 320 kbps.
- WMA bit rates: 32 - 192kbps.
- An MP3 file consists of audio data compressed with the MPEG1 Audio Layer-3 file coding.
- A WMA file (Windows Media Audio) consists of data which have been compressed with the Windows Media Codec.
- The filenames must have the extension ".mp3" or ".wma".
- This unit cannot play back any DRM-protected contents.

## Compatibility of MP3 files

- The physical format of the CD-R must conform to ISO 9660 and JOLIET.
  - The physical format of the DVD+R/RW must correspond to ISO 9660 (UDF Bridge-Format).
  - The total number of files in a folder on the disc may not exceed 1999.
- **Please note that permission is required for downloading MP3/WMA files and music from the Internet. The required permission must be obtained from the respective copyright owners or their representatives.**

# Photo mode

## Show photos

The recorder can display JPEG files under the following conditions. The maximum size of a JPEG file may not exceed 4 MB. The total number of files and folders is 1999. The file extension must be ".jpg". The progressive and loss-free compression of JPEG files is not supported.

ASSIST

Call main menu.

◀ ▶ Select **Photo**.

▲ ▼ Select **DISC / USB**.

Confirm selection with **OK**.

The **Photo List** menu appears on the screen.

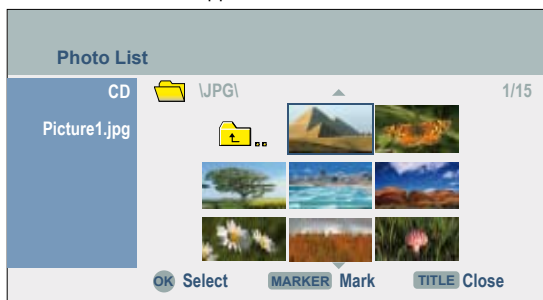

▲ ▼ ◀ ▶ Select desired photo.

**OK** display options.

▲ ▼ Select **Full Screen**.

Confirm with **OK**. The photo is displayed.

⇒ If the thumbnail is displayed in black, this JPEG file cannot be displayed.



**OK** hide / show menu bar.

Go to previous / next photo with **P-** / **P+**.

▲ ▼ Rotate photo 90° to left / right.



Press the blue button briefly to select a picture for a slide show.



Exit photo display, return to **Photo List** menu.

## Options in the "Photo List" menu

**Open** Open folder and show contents.

**Full Screen** Show photo.

**Slide Show** Automatically running photo sequence.

## Slide Show

▲ ▼ Select Slide Show option in the **Photo List** menu.

Confirm with **OK**. The **Slide Show** menu appears.

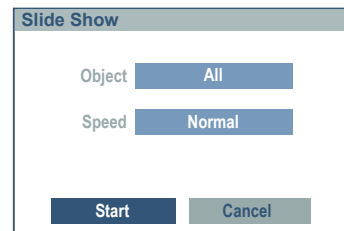

▲ ▼ ◀ ▶ Select options and confirm with **OK**.

**Object** Display **Selected** files or **All** files.

**Speed** Speed of the slide show: **Slow**, **Normal** or **Fast**.

▲ ▼ ◀ ▶ Select **Start** button.

**OK** start slide show.



Stop slide show.



Continue slide show.



End slide show, return to Photo menu.

# USB mode

## About the system

You can play MP3/WMA audio files or show pictures in JPEG format which are stored on a USB stick or a memory card in a USB card reader. You can operate the USB card reader with the remote control of the Loewe recorder. The memory medium must be formatted in FAT 16 or 32 format. Memory cards with other formats cannot be read.

- ➡ Keep memory media out of reach of children. See a doctor immediately in case of swallowing.
- ➡ The reading time of the connected memory medium depends on its performance capacity, the number of files, the file size or resolution.
- ➡ The front flap of the recorder cannot be closed while a memory medium is plugged into the USB socket.
- ➡ This device is compatible with Flash-USB memory media which support USB 1.1.
- ➡ Certain USB memory media may not be supported by this device.
- ➡ Never remove the USB memory medium during access (e.g. playback). This can lead to malfunctioning of the device.

## Plugging in the USB memory medium

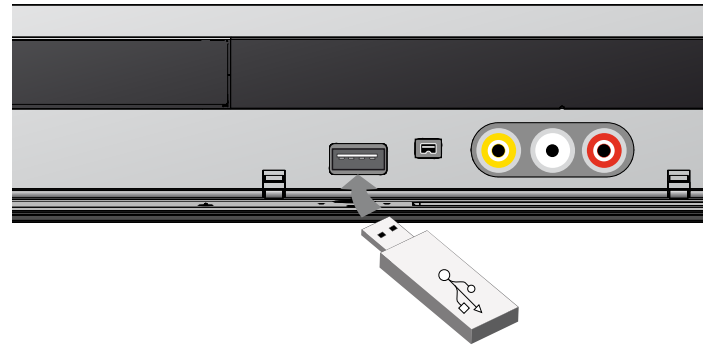

Open the front flap.  
Plug the USB memory medium into the USB socket. Make sure the USB plug is the right way round.

## Audio mode

See "Audio mode" on page 42 for operation.

## Photo mode

See "Photo mode" on page 44 for operation.

# Remote control Assist – USB operation

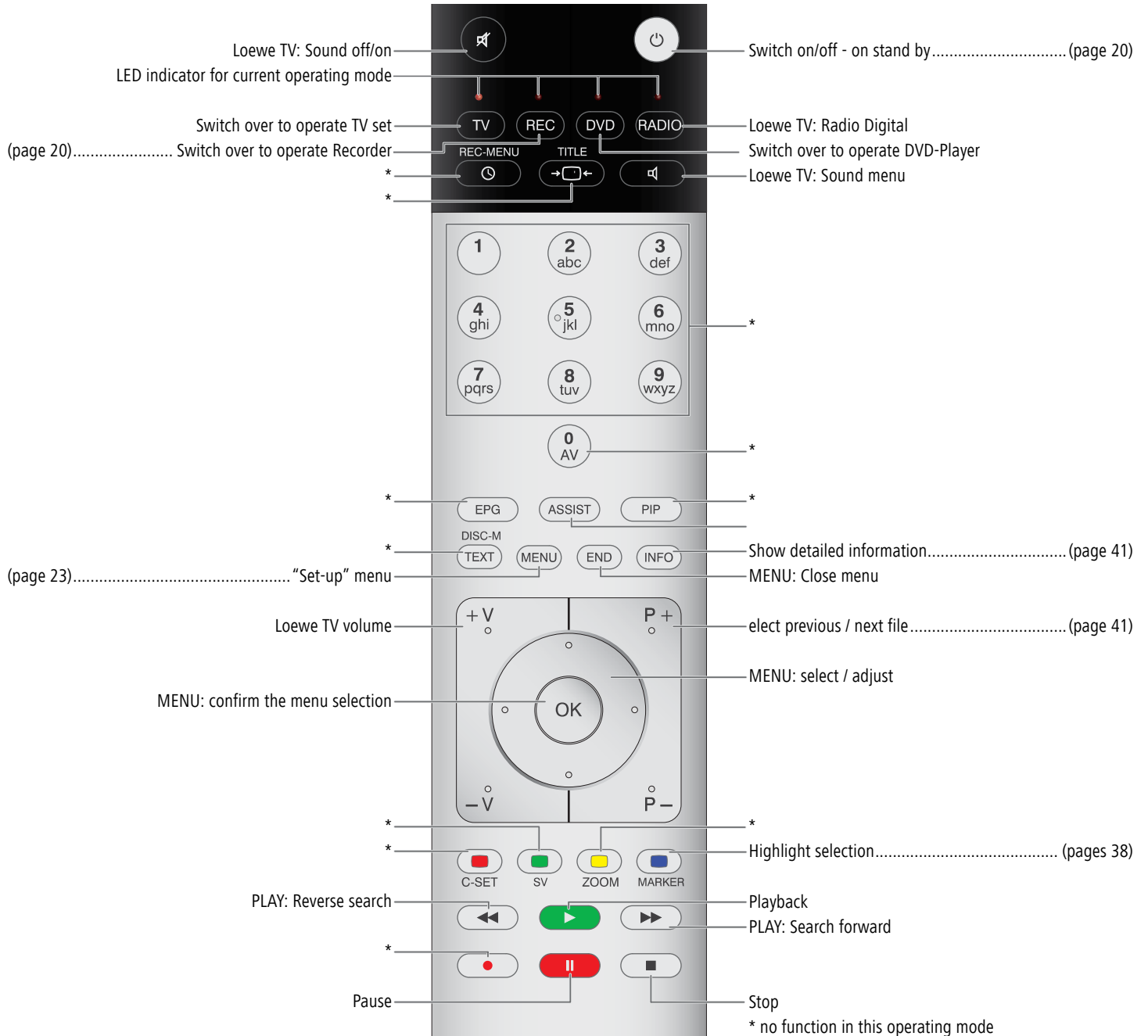

# Recording

## Manual Record

Proceed as follows to make video recordings.

Switch on the recorder. Insert a recordable disc for DVD recordings. A new disc is initialised by the recorder (on request) when inserted (page 32).

If required, select **Rec Mode Set** (page 31).



Switch the recorder input to the signal source you wish to record from with the number buttons, the **P+** / **P-** buttons or the **0 AV** button. The station number, name and current sound status are displayed on the screen.



Start recording. (**REC** lights up in the display window of the recorder). The recording starts immediately and continues until the disc is full or you interrupt the recording. Every additional pressing of the button prolongs the recording time by 10 minutes.



During recording: Show remaining recording time. Every additional pressing of the button prolongs the recording time by 10 minutes.



Interrupt recording. Press again to continue.



Show status of recording.



End recording.

➡ If the recorder is disconnected from the mains during recording (or in case of a power failure) or the recording is interrupted manually with the On-Off button, the rest of the recording is lost.

## Timer Recording

This recorder can be programmed to record up to 16 programs within one month. For programmed recordings the timer must be informed which signal sources (TV stations or from AV devices) are to be recorded and the respective start and stop time.

Switch on the recorder. Insert a rewritable disc for DVD recordings.



Press twice to open the **Timer Record** menu.

| PR | Date    | Start time | End time | Mode | VPS/PDC |
|----|---------|------------|----------|------|---------|
| 31 | 8/12 Fr | 20:15      | 22:00    | SQ   | Off     |

S23 K1

REC-MENU Timer Record List OK OK END Close

**PR** Select the stations or an external input.

**Date** Select the data up to one month in advance.

**Start time** Defines the start time for the recording.

**End time** Defines the end of the recording.

**Mode** Set the **recording quality** if necessary (page 31).

**VPS/PDC** The VPS/PDC system adapts the recording time automatically to changes in the program start time for recordings via the integrated tuner. Set the VPS/PDC time and the date of the program you want to record. You will find these in your TV guide or in the teletext.

Enter the necessary information for your timer recording(s).

◀ ▶ Move the cursor to the previous / next column.

▲ ▼ Edit the setting at the current cursor position.

**OK** saves timer data.



Exit **Timer Record** menu without saving.



Call **Timer Record List** menu.



Switch recorder to standby.

# Recording

- ➔ The recorder must be in standby mode for timer recording to start automatically.
- ➔ Please note that not every station operates with VPS/PDC.
- ➔ There must be at least three minutes free capacity on the recording medium for a recording. The recorder switches on about 2 minutes before the programmed time and runs up to about 2 minutes after the programmed time.
- ➔ The current time and the current date must be set in the recorder (page 27).
- ➔ Select the audio channel for two-language TV recordings in the "TV Rec Audio" menu (page 29).
- ➔ In standby mode the Timer symbol lights up in the display window when a timer recording is programmed (page 6).

## Timer recordings with the ShowView® system

Programming timer recordings with this system is child's play. Most television schedule publications include the ShowView code numbers along with the information about the programmes. So when you want to make a timer recording of a programme, you only need to key in the appropriate ShowView code number. The date, start time, end time and station are set automatically. You only need to set the recording quality and specify whether it is to be a one-off or repeated recording. You can save up to 16 timer programmes on the recorder.

 Select **ShowView** menu with the green button.

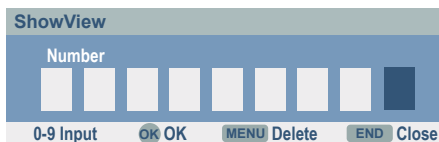

Enter the ShowView number.



Delete input errors.

Confirm with **OK**. The **Timer Record** menu appears.

Check and, if necessary, correct the settings as described under "Timer Recording" (page 47).

- ➔ The ShowView function is only possible for recordings made with the integrated analogue receiver (tuner) of the recorder. This function is not possible when recording from an external source (e.g. from a connected SAT receiver).

## Timer Record List

### Checking the timer programming



Open the **Timer Record List** menu.

| PR    | Date     | Start Time | Duration | Mode | VPS /PDC | Check   | 1/1 |
|-------|----------|------------|----------|------|----------|---------|-----|
| NEW   |          |            |          |      |          |         |     |
| PR-01 | 8/12 Fri | 20:15      | 105min   | SQ   | OFF      | Rec. OK |     |

### Editing a timer programming



▲ ▼ Select timer recording.

**OK** edit selected programming.



Delete selected programming.



or **New** opens "Timer Record" menu (page 47).

### Recording conditions

With the programmed timer the recorder does not record under the following conditions:

- No disc or a non-rewritable disc inserted.
- The power supply is interrupted or the recorder is not ready.
- There are already 99 recorded titles on the disc.
- The remaining capacity of the recording medium is less than three minutes recording time.

### You cannot program the timer under the following circumstances:

- A recording is already in progress.
- 16 timer recordings have already been programmed.

### Multiple overlapping timer programs:

- The earlier recording takes priority.
  - When the earlier recording ends, the later one will start.
- ➔ If the disc is damaged, it is possible that the recording will not be done properly. Even if the "Rec. OK" message appears in the "Check" field, this is not necessarily true in this case.

# Recording

## Record from external sources

You can record from an external source ( e.g. SAT-TV set, SAT receiver, camcorder or video recorder).

The device you want to record from must be connected to the recorder properly. You will find further information on page 16.

Switch on the recorder and set the desired memory medium under TV in the main menu. Insert a rewritable DVD if necessary.



Select source.

- AV1** AV1 AUDIO VIDEO to the rear of the housing.
- AV2** AV2 DECODER to the rear of the housing.
- AV3** AUDIO IN 3 / VIDEO IN 3 to the front of the housing.
- DV** DV IN to the front of the housing.
- PRnn** Integrated tuner on station nn.

Set the recording quality (page 31).

For further operation see “Manual Record” on page 47 or “Timer Recording” on page 47.

- ➡ If you operate this recorder with a Loewe Flat-TV set, the recording wizard of the TV set controls the recording via Digital Link Plus. This has the advantages of easier operation, especially when recording digital stations. You will find further information in the TV user guide under “Operation of additional equipment – Timer recordings”.
- ➡ If your source is copy-protected by Copy-Guard, you cannot use this recorder to record from it. Read the copyright notes on page 14.

## Digital Video

### General “DV” information

With DV (Digital Video, also known as i.LINK), you can use a DV cable as the audio, video, data and control signals input / output to connect a camcorder that has DV to this recorder. The i.LINK interface complies with the IEEE 1394-1995 standard. “i.LINK” and the “i.LINK” logo are trademarks.

- This recorder is only compatible with “DV 25” format camcorders. Digital satellite tuners and digital VHS video recorders are not compatible.
- You cannot connect more than one DV cam-corder at a time to this recorder.
- You cannot control this recorder with external devices that are connected via the **DV IN** socket (incl. two Recorders).
- The camcorder connected via the **DV IN** socket cannot necessarily, in every case, be controlled.
- Digital camcorders can usually record audio as 16 bit/48 kHz stereo or twin stereo tracks with 12 bit/32 kHz. This recorder can only record one stereo audio track. Set “DV Rec Audio” as required or Audio 1 or Audio 2 (page 32).
- The sampling rate of the digital sound input to the **DV IN** socket must be either 32 or 48 kHz (not 44.1 kHz).
- Recording may suffer from interference if the camcorder stops playing back, if a part of the tape that has not been recorded on is played back, if the electricity supply to the camcorder is cut off, or if the DV cable comes out.
- When “DV Rec Audio” is set to “Audio 2” and there is no Audio 2 signal, “DV Audio” will automatically be set to “Audio 1”.

### DV messages

When you are using the **DV IN** socket, the following messages may appear on the screen.

**Not connected to camcorder:** The camcorder is not properly connected, or the camcorder is switched off.

**Too many devices connected:** This recorder’s DV socket only supports the connection of one camcorder.

**Check tape:** There is no tape in the device that is connected.

**Incompatible device:** The recorder is unable to control the camcorder.

**Information is being reloaded:** The camcorder is updating data for DV.

**Camera mode:** The camcorder is set to camera mode.

# Recording

## Troubleshooting

If you are not receiving images and/or sound via the DV IN socket, check the following:

- The DV cable must be properly connected.
  - Switch off the camcorder that is connected, and switch it back on.
  - Tune the audio input in to the recorder.
- ➡ This recorder cannot necessarily control every camcorder that is connected to it.

## Recording from a digital camcorder

You can record from a camcorder that is connected to the **DV IN** socket in the recorder's front panel. You can use the recorder's remote to control a camcorder and the recorder. Before recording, make sure that the audio input has been set up for the DV IN socket (page 32).

The digital camcorder must be connected to the DV IN socket at the front of the housing. Further information can be found on page 20.

You can choose from between Audio 1 (original audio) and Audio 2 (overdubbed audio).

The DV input is set using the "DV Rec Audio" submenu of the main menu (page 32).



Select DV input.

"DV" is displayed in the display window of the recorder and on the screen.

Search the position on the camcorder tape from which you want to record.

For optimum results, interrupt play-back of the camcorder at the point from which you want to record. Depending on the camcorder you can operate the functions **STOP**, **PLAY** and **PAUSE** with this recorder.



Start recording.

The recording is stopped automatically when the recorder detects no signal.



Interrupt recording. Press again to continue.



End recording.

- ➡ You cannot use the recorder to control the camcorder while recording is in progress.
- ➡ In Video mode, the last frame of the recording is shown on the screen for a short time after recording has ended.
- ➡ For timer recordings to work properly on this recorder, the digital camcorder should be switched on and operational.

# Edit recordings

## Menu Title List and Chapter List

Under the Title List menu, video contents on unfinalised DVDs in VR mode can be edited. The available edit functions are dependent on whether video on a DVD in VR mode or whether original contents or playlists are edited.

DVD-RW discs in VR-mode can be edited in two ways. Original contents of the disc can be edited directly or a playlist can be created and edited. The playlist does not change the contents of the disc but controls its play-back.



Pause playing.



Select **Title List** menu.



▲ ▼ ◀ ▶ Select title.



Change between Original and Playlist menu when editing in DVD VR mode.



The available options are displayed at the left. The titles (or chapters) on the DVD are displayed on the right of the screen.



Information about the selected title in the Title List menu.



Close menu.



1. Different menu options are displayed depending on the memory medium.
    - Combine** Connects two titles or chapters as one (page 56).
    - Delete** Deletes the title or the chapter (page 54).
    - Delete part** Deletes part of the title (page 54).
    - Divide** Divides a title into two (page 56).
    - Full Play** Starts playing the selected title including hidden chapters.
    - Hide** Hides (shows) the selected title or the chapter (page 57).
    - Move** Moves a chapter in the Chapter List / Playlist menu to another position (page 57).
    - Play** Starts playing the selected title or chapter. Hidden titles and chapters on the DVD+R/RW are not played.
    - Playlist Add** Adds the title or chapter to a new playlist (page 53).
    - Protect** Prevents accidental recording, editing or deleting of a title (page 57).
    - Title Name** Edits the title name (page 55).
  - Search Chapter** Display Chapter List of title.
  - Search Time** Time at which title starts playing (page 55).
  - Title** Displays the title list of the chapter.
2. Displays the recording quality, free memory space and a progress display of the elapsed playing time.
  3. Name of the current memory medium.
  4. Currently selected title.
  5. Thumbnail.
  6. Shows the title name, the recording date and the length of the recording.

# Edit recordings

## Edit Original and Playlist

### Title, Chapter and Parts

Titles of the original content of the disc contain one or more chapters. When inserting a title in the playlist, all the chapters within this title also appear. That means that chapters in the playlist behave exactly the same as chapters on a DVD-Video disc. Parts are sequences of the original or playlist titles. Parts can be added to or deleted from the Original and Playlist menu. When adding a chapter or title to the Playlist, a new title is created consisting of a sequence (= chapter) of an original title. When deleting, part of the title of the Original or Playlist menu is deleted.

- ➡ If you use the Delete, Edit and Move functions, the start and end frames may not correspond exactly with the start and end points. A short pause may be made between edits during play-back of the playlist. This is not a malfunction.

### Original and Playlist

-RW VR

The terms Original and Playlist are used in this user guide for the actual contents and the edited contents.





**Original** The contents of the actual recordings on the disc.

**Playlist** On DVDs a "Playlist" of the contents to be played and the play times is created for editing. The recorder plays the disc according to the playlist.

## Add chapter markers

-RW VR +RW +R

Chapters can be created by inserting chapter markers at the desired positions within a title.

-     **C-SET** During recording or playing at the position at which a new chapter is to be inserted.

A chapter marker symbol appears on the screen.

- ➡ Chapter markers are inserted automatically at regular intervals. You can change these intervals in the "Recording" menu (see "Auto Chapter" on page 32).

## Create new Playlist

-RW VR

Use this function to add an original title or a chapter to the playlist. The whole title is added to the playlist (you can delete parts you will not need later; see "Delete title/chapter from Original/Playlist" on page 54).

The title appears in the playlist together with the chapter markers of the original. When adding other chapter markers to the original later, however, these are not copied automatically to the titles of the playlist. You can add a maximum 999 chapters to a disc. To add only one chapter of a title, read "Add title/chapter to Playlist" on page 53.



Select Title List/Chapter List Original menu.

▲ ▼ ◀ ▶ Select title/chapter.

Confirm with **OK**.

The available options are displayed at the left.

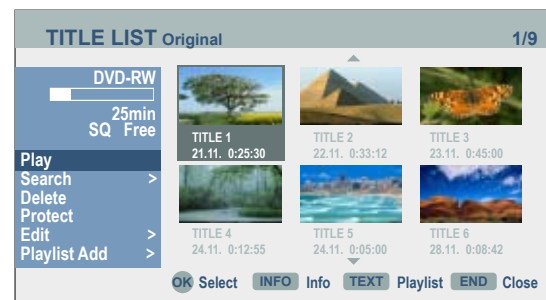

▲ ▼ Select **Playlist Add**.

Confirm with **OK**.

# Edit recordings

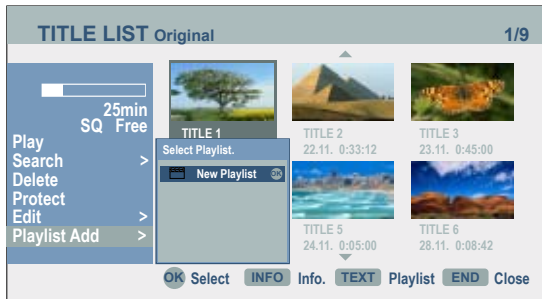

▲ ▼ Select **New Playlist**.

Confirm with **OK**.

The new title appears in the updated Playlist. All chapters of the title are added to the Playlist.

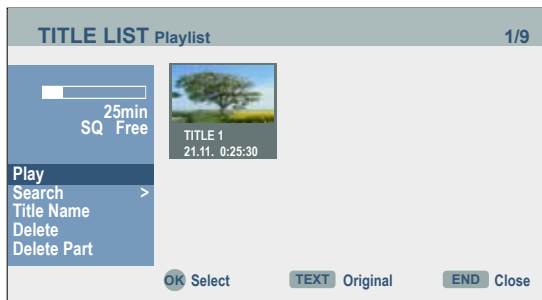

## Add title/chapter to the Playlist

-RW VR

You can add an original title or a chapter to a Playlist title even if it is already registered.



▲ ▼ ◀ ▶ Select a title/chapter in the Title List Original or Chapter List Original menu which is to be inserted in the Playlist.

Confirm with **OK**.

The available options are displayed at the left.

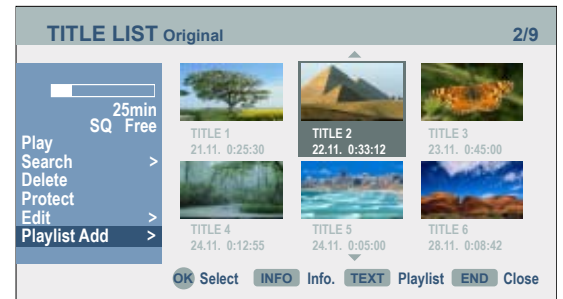

▲ ▼ Select **Playlist Add**.

Confirm with **OK**.

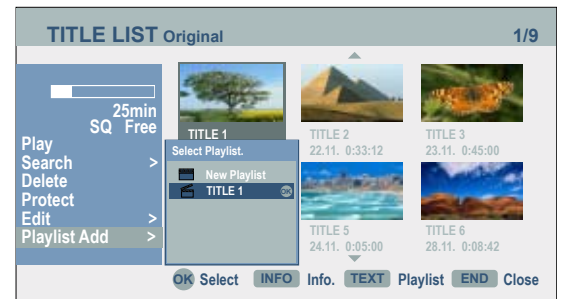

▲ ▼ ◀ ▶ Select Title List Playlist in which a title or chapter is to be inserted.

Confirm with **OK**.

The added chapters are displayed in the menu (**Search - Chapter**) **Chapter List - Playlist**.

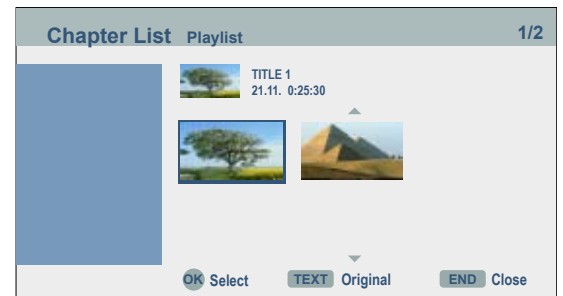

End editing of the Playlist.

# Edit recordings

## Delete title/chapter from Original/Playlist

When you delete a title or a chapter from the playlist, you only remove the title/chapter from the playlist.

When you delete a title or chapter from the original list, title/chapter are deleted from the disc and the time remaining for recording is prolonged again. Titles or chapters deleted from the original are also deleted from the playlist.

- ➔ You cannot delete chapters with a playing time of less than 5 seconds.



▲ ▼ ◀ ▶ Select a title/chapter in the menu **Title List - Original** or **Chapter List - Original** which is to be deleted from the playlist.

Confirm with **OK**.

The available options are displayed at the left.

▲ ▼ Select **Delete**.

Example: **Title List**:

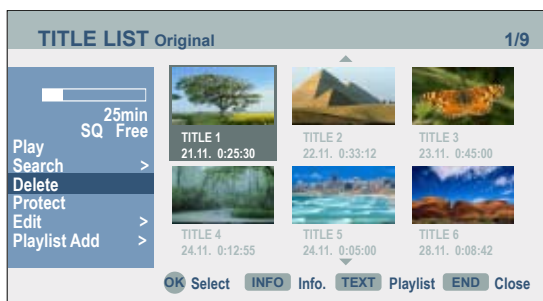

Confirm with **OK**. A delete prompt is displayed.

▲ ▼ Select **yes**.

Confirm with **OK**. The chapter or title is deleted.

**OK** displays the updated menu.

END

End editing.

- ➔ For DVD+R/DVD+RW recordings the deleted title is renamed after "Deleted Title".
- ➔ In case of fast deleting of more than two titles in succession, the titles are combined as one.
- ➔ When deleting a title or chapter, the remaining recording time is increased on the DVD+RW only by the size of the title which was deleted at the end.

## Delete part

-RW vR

You can delete a part which you no longer want in the title.



▲ ▼ ◀ ▶ Select title in the Title List menu.

Confirm with **OK**.

The available options are displayed at the left.

▲ ▼ ▶ Select **Edit – Delete Part**.

Confirm with **OK**.

The **Edit** menu (Delete Part) is displayed.

The **Start point** symbol is marked.

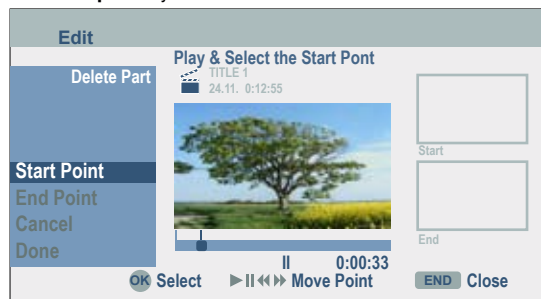

◀ ▶ Start play-back and search the start point with single frame, search and slow motion.

**OK** at the start point of the clip to be deleted.

The **End point** symbol is marked.



◀ ▶ Search the end point with single frame, search and slow motion.

Confirm with **OK**.

▲ ▼ End editing with **Done**.

Confirm with **OK**. A delete prompt is displayed.

◀ ▶ Select **yes**.

Confirm with **OK**. The selected part is deleted from the title.

◀ ▶ Select **Cancel** to reject the editing.

# Edit recordings

## Title Name

You can assign names to the titles of Original or Playlist. The names may have a maximum 32 characters.

▲ ▼ ◀ ▶ Select title to be renamed in the **Title List** menu.

Confirm with **OK**. The available options are displayed at the left.

▲ ▼ Select **Title Name/Rename**.

Confirm with **OK**.

The **Keyboard** menu is displayed.



### Explanations of the options:

**English/Latin Capital** Switches the keyboard to capitals.

**English/Latin Small** Switches the keyboard to small letters.

**Symbol** Switches the keyboard to special characters.

**ABC...123** Inserts the selected character at the cursor position (shaded grey for special characters).

**OK** Save setting and exit.

**Cancel** Exit setting without saving.

**Space** Inserts a space at the cursor.

**Delete** Deletes characters to the left of the cursor.

◀ ▶ ▲ ▼ Moves the marker in the selection.

Inserts a space at the cursor.

Deletes the characters to the right of the cursor.

Deletes the character to the left of the cursor.

**P+ / P-** Moves the cursor to the left or right.

Switches the keyboard back and forth among capitals, small letters and symbols.



Select the OK button and save with **OK**.

➡ On DVD-R-, DVD+R- or DVD+RW discs, the entered name is only displayed after finalisation.

## Select title start point

*-RW VR -RW Video +RW +R -R*

You can select the start point of the title.



▲ ▼ ◀ ▶ Select title in the **Title List** menu.

Confirm with **OK**.

The available options are displayed at the left.

▲ ▼ Select **Search - Time**.

Confirm with **OK**.

The **Search** menu is displayed on the screen.

Example:

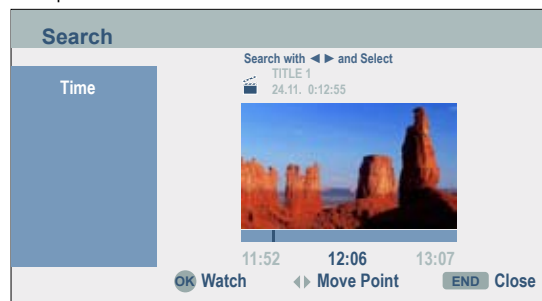

◀ ▶ Select the desired start point.

The time changes in one minute steps.

◀ ▶ Keep pressed to increase the time in steps of 5 minutes.

**OK** to start at the desired point.

## Select chapter

*-RW VR -RW Video +RW +R -R*

You can select any chapter from a title.



▲ ▼ ◀ ▶ Select title in the **Title List** menu.

Confirm with **OK**.

The available options are displayed at the left.

▲ ▼ Select **Search - Chapter**.

Confirm with **OK**.

The **Chapter List** menu is displayed.

▲ ▼ ◀ ▶ Select desired chapter.

**OK** to start at the selected point.

# Edit recordings

## Divide title

+RW

With this function you can divide a title into two new titles.



▲ ▼ ◀ ▶ Select title to be divided in the **Title List** menu.

Confirm with **OK**.

The available options are displayed at the left.

▲ ▼ Select **Edit - Divide**.

Example:

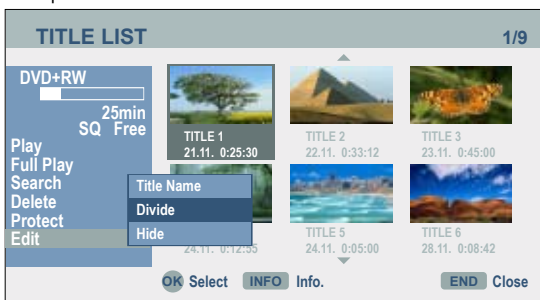

Confirm with **OK**.

The menu **Edit - Divide** is displayed and the **Divide** option is marked.

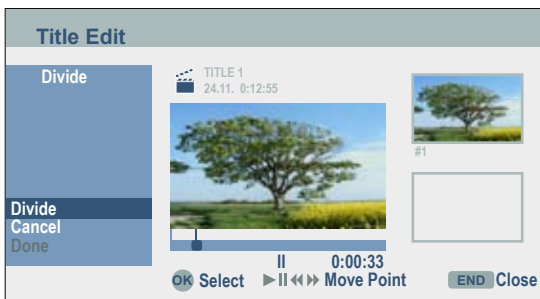

◀ ▶ Seek the start point for dividing the title with single frame, seek and slow motion.



▲ ▼ Select **Divide**.

Confirm with **OK**.



▲ ▼ Select **Done**.

Confirm with **OK**. The title is divided into two new titles. This process may last up to 4 minutes.

⇒ Division points must be at least three seconds apart.

## Combine chapters

-RW VR +RW +R

With this function two adjacent playlist or original chapters can be united.

⇒ This function is not available if the title contains one chapter.



▲ ▼ ◀ ▶ The second of the two chapters to be united should be selected in the **(Title List - Search - Chapter) Chapter List** menu.

Confirm with **OK**.

The available options are displayed at the left.

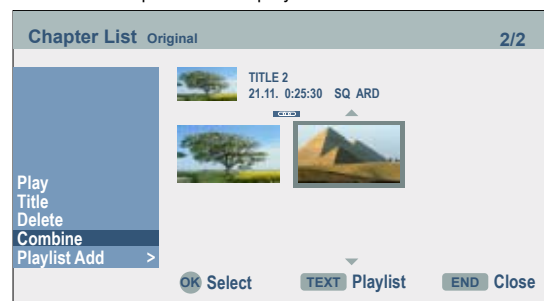

▲ ▼ Select **Combine**. The combination indicator is shown between the two chapters which you can join.

Confirm with **OK**.

# Edit recordings

## Move Playlists Chapters

-RW VR

With this function the play-back order of the chapters within Playlists can be edited.

➔ This function is not available if only one chapter is available.



▲ ▼ ◀ ▶ Select chapter in the **Chapter List-Playlist** menu.

Confirm with **OK**.

The available options are displayed at the left.

▲ ▼ Select **Move**.

Confirm with **OK**.

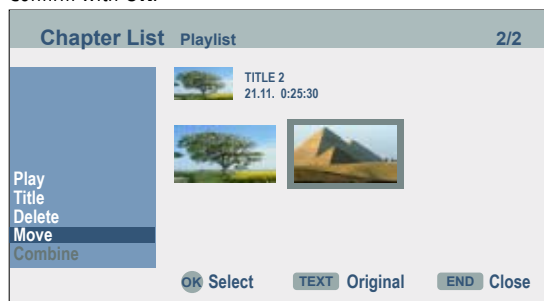

▲ ▼ ◀ ▶ Select position of chapter.

Confirm with **OK**. The updated menu is displayed.

## Hide title/chapter

+RW +R

Playing of selected chapters or titles can be skipped by the disc.



▲ ▼ ◀ ▶ Select the chapters to be hidden in the **Title List** or **Chapter List** menu.

Confirm with **OK**.

The available options are displayed at the left.

▲ ▼ Select **Hide**.

Confirm with **OK**. The thumbnail of the chapter or title is hidden.

➔ When selecting, a hidden chapter or title can be shown in the Title List or Chapter List menu by selecting the **Edit - Display** option in the menu. Then the chapter or title is displayed.

Example: Title List (DVD+RW):

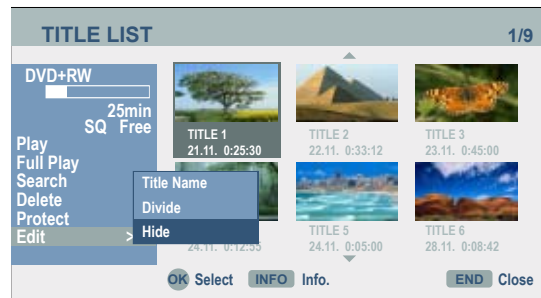

## Protect title

-RW VR +RW +R

This function prevents accidental overwriting, editing or deleting of a title.



Select **Title List** menu.

▲ ▼ ◀ ▶ Select the title to be protected.

Confirm with **OK**.

The available options are displayed at the left.

▲ ▼ Select **Protect**.

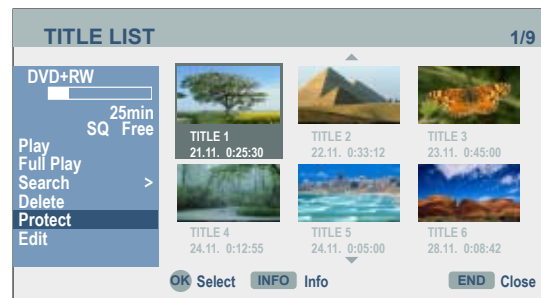

Confirm with **OK**. The lock marker appears in the title thumbnail.

➔ If you select a title which is already protected in the Title List menu, this can be enabled by selecting Unprotected in the options of the Title List menu. Then the title can be edited and deleted.

# Edit recordings

## Overwrite recordings

+RW

Proceed as follows to overwrite a recorded title with a new video recording:

- ➡ This function is not possible for DVD+R because the recordings are always made at the end of the disc here.



Switch the recorder input to the signal source you wish to record from with the number buttons, the **P+** / **P-** buttons or the **0 AV** button.

MENU

Select Title List menu.

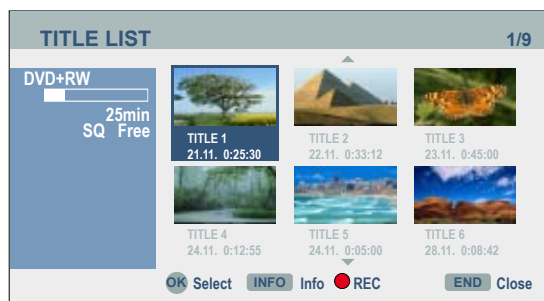

▲ ▼ ◀ ▶ Select title to be overwritten.

Start overwriting.



The overwriting begins at the start point of the selected title.



End recording. The new title is created and the updated menu is displayed.

- ➡ This function is not possible for protected titles (page 57).
- ➡ If the overwriting title is longer than the recorded title, the following title is overwritten. However, if the following title is protected, the recording stops at the start point of this title.
- ➡ If the length of the selected title is shorter than 10 seconds, the following title is overwritten. However, if this title is protected, recording stops.

## Title List menus on other devices

+RW +R

The **Title List** menu can be displayed on DVD players on which DVD+RW or DVD+R discs can be played.

Insert a written DVD+R or DVD+RW disc.

Select the Title menu (see user guide of the respective unit).

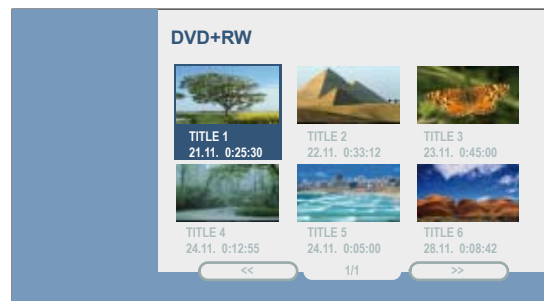

## Playing on other devices

Finalised discs, finalised DVD+R or DVD+RW discs recorded in video mode can be played on most DVD players. Some players can play finalised/unfinalised DVD-RW discs recorded in VR mode. Look in the player user guide to find out which disc formats it supports. In the finalisation the recordings are "fixed" so that the disc can be played on normal DVD players or computers with a DVD-ROM drive. In the finalisation of a disc in video mode, a menu is created for controlling the disc. Access is obtained with the **MENU** or **TITLE** buttons. For finalisation of a disc, please read "Finalisation" on page 33.

- ➡ Unfinalised DVD+RW discs can be played on normal DVD players.
- ➡ Edited contents of a DVD+RW disc can only be played on normal DVD players after finalisation.
- ➡ Edited contents of a DVD+R disc (hidden files, combined chapters, added chapter markers etc.) cannot be played on normal DVD players.

# Troubleshooting

| <b>Problem</b>  | <b>Possible cause</b>  | <b>Remedy</b>  |
|---|--|--|
| No function.  | The mains cable is not plugged in.                                   | Plug the mains cable firmly into the set and the wall socket.  |
| No image.   | The television is not switched to receive signals from the Recorder. | Select the right video input mode on the television, so that the image from the Recorder appears on the television screen. |
|   | The SCART cable is not properly connected.                           | Connect the SCART cable properly.  |
|   | The television that is connected is switched off.                    | Switch the television on.  |
| No sound.   | The connected audio equipment is not switched to DVD playback.       | Set the audio receiver so that you can hear the sound playing on your Recorder.  |
|   | The audio cables are not properly connected.                         | Connect the audio cable properly.  |
|   | The connected audio equipment is switched off.                       | Switch on the audio equipment that is connected.   |
|   | The audio connection cable is faulty.                                | Change it.   |
| Inferior picture quality.   | The disc is dirty.   | Clean the disc.  |
| Playback not possible.  | There is no disc.  | Insert a disc. (Check that the disc display comes on in the display window.)   |
|   | A non-playable disc has been inserted.                               | Insert a playable disc. (Check the disc type, the colour system and the region code.)                                      |
|   | The disc has not been inserted with the playable side downwards.     | Insert the disc with the playable side downwards.  |
|   | The disc has not been properly placed in the guide.                  | Position the disc properly into the guide in the disc drawer.  |
|   | The disc is dirty.   | Clean the disc.  |
|   | A security rating has been set.                                      | Cancel the security rating or change the protection.   |
| There is interference with images from an external source.  | The video signal from the external component is copy-protected.      | You cannot get a connection from this recorder. Connect the component directly into the television.                        |
| A channel is skipped when using <b>P+</b> / <b>P-</b> .   | The channels have not been saved in the recorder.                    | Retune the channels. See channel tuning on page 25.  |
| The image or sound on the transmission channel is weak or absent.   | Loose antenna or cable.  | Tighten the connections or change the cable.   |
| The camcorder image is not displaying.  | The camcorder is switched off.                                       | Switch on the camcorder and make sure you are using it properly.   |
| The camcorder image is not appearing on the television screen when using the <b>AV</b> input or <b>DV IN</b> to the Recorder. | The Recorder AV selection is wrong.                                  | Select the input channel (AV1, AV2, DV etc.) with DVD-AV.  |
| A disc that was recorded to from this Recorder cannot be played on a different DVD player.                                    | The disc was recorded in video mode.                                 | Finalising the disc (page 33).   |

# Troubleshooting

| <b>Problem</b>   | <b>Possible cause</b>   | <b>Remedy</b>   |
|--|---|---|
| A disc that was recorded to from this Recorder cannot be played on a different DVD player. | Some players do not play discs with finalisation in video mode.   | No solution.  |
|  | The disc was recorded in VR mode.   | The other player must be RW-compatible.   |
|  | The ability of CD-R / RWs (MP3/WMA, JPEG) and DVD+R / RWs and DVD-R / RWs is influenced by the recording equipment, recording methods and data media. Therefore, there may be problems occasionally when playing on conventional DVD players. | No solution.  |
| Playback not possible or unsuccessful.   | There is insufficient space on the disc.  | Use a different disc.   |
|  | The source that you want to record is copy-protected.   | You cannot record the source.   |
|  | Copy-protected broadcasts cannot be recorded on a video mode disc.  | Use a disc formatted in the VR mode for once copiable material.                                       |
| Timer recording not possible.  | The time has not been set correctly on the recorder.  | Set the correct time. See "Setting the time automatically" or "Setting the time manually" on page 27. |
|  | The timer was wrongly programmed.   | Re-program the timer. See "Timer recording" on page 47.   |
|  | The time between programming the timer and the start of recording is too short.   | The recording's start time must be at least 3 minutes into the future.                                |
|  | After programming, the timer recording symbol is no longer displayed.   | Re-program the timer.   |
| Stereo-audio recording and/or playback unavailable.  | The television is not stereo-compatible or the broadcast transmission is not in stereo format.  | No solution.  |
|  | The Recorder's A/V Out sockets are not connected to the TV's A/V In sockets.  | Make the A/V connections.   |
|  | The Recorder's audio/video Out has not been selected for the television.  | Select the AUX or A/V source as the TV input.   |
| The remote control is not working properly.  | The remote control's batteries have run out.  | Replace the old batteries with new ones.  |
| Interference is visible at the top and bottom edges of the screen.                         | Unfavourable resolution setting in HDMI mode.   | Set the resolution to 1080i with the <b>RES</b> button (page 36).                                     |
| The recorder is not working normally.  | The unit is in an undefined state.  | Reset the recorder (page 20).   |

# Technical Specifications

## General

|                       |  |
|-----------------------|--|
| ViewVision            | Item No. 67503A/D/T00  |
| ViewVision Secam L    | Item No. 67504A/D/T00  |
| Power supply          | AC 200-240V, 50/60 Hz  |
| Power consumption     | During operation: 22 W<br>In standby mode: <1 W<br>(with energy save function) |
| Dimensions (approx.)  | 430 x 60 x 280 mm (W x H x D)  |
| Weight (approx.)      | 3,1 kg   |
| Operating temperature | 5 °C to 35 °C  |
| Humidity              | 5 % to 90 %  |
| TV system             | ViewVision PAL B/G, I, Secam DK<br>ViewVision PAL B/G, Secam L                 |
| Recording format      | PAL  |

## Recording

|                  |                                 |
|------------------|---------------------------------|
| Recording format | DVD Video-Recording, DVD-VIDEO  |
| Writable media   | DVD-RW, DVD-R,<br>DVD+RW, DVD+R |

## Video recording format

|                    |                      |
|--------------------|----------------------|
| Sampling frequency | 27MHz                |
| Compression format | MPEG 2 (VBR support) |

## Audio recording format

|                    |               |
|--------------------|---------------|
| Sampling frequency | 48kHz         |
| Compression format | Dolby Digital |

## Playback

|                       |   |
|-----------------------|---|
| Frequency response    | DVD (PCM 48 kHz): 8 Hz to 20kHz,<br>CD: 8 Hz to 20 kHz<br>DVD (PCM 96 kHz): 8 Hz to 44 kHz<br>> 100 dB (AUDIO OUT connection) |
| Signal-to-noise ratio | < 0,008% (AUDIO OUT connection)   |
| Harmonic distortion   | > 95 dB (AUDIO OUT connection)  |
| Dynamic range         |   |

## Inputs

|               |  |
|---------------|--|
| IN (from ANT) | Aerial input, 75 ohms  |
| VIDEO IN      | 1.0 Vp-p 75 ohms, negative sync. ,<br>RCA socket / SCART x 2 |
| AUDIO IN      | 0 dBm > 47 kOhm, RCA socket<br>(L, R) / SCART x 2            |
| DV IN         | 4 Pins (i.LINK/IEEE 1394-Standard/DV-25)                     |
| USB           | V1.1   |

## Outputs

|                               |   |
|-------------------------------|---|
| HDMI OUT                      | Type A, 19 Pin, LVDS digital, V1.2a   |
| VIDEO OUT                     | 1.0 Vp-p 75 ohms, negative Sync.,<br>SCART x2   |
| S-VIDEO OUT                   | (Y) 1,0 V (p-p), 75 ohms , negative Sync.,<br>(C) 0,3 V (p-p) 75 ohms, Mini DIN 4-pin x 1   |
| COMPONENT VIDEO OUT           | (Y) 1,0 V (p-p), 75 ohms, negative Sync.,<br>RCA socket x 1 (Pb)/(Pr) 0,7 V (p-p),<br>75 ohms, RCA socket x 2<br>0,5 V (p-p), 75 ohms, RCA socket x 1 |
| Audio output (digital audio)  | Optical connector x 1 (TOS-Link)  |
| Audio output (optical audio)  | 2,0 Vrms (1 kHz, 0 dB), 600 ohms,<br>RCA socket (L, R) x 1 / SCART  |
| Audio output (analogue audio) |   |

## Masthead

The Loewe Opta GmbH is a share company of German law with its Head Office in Kronach.

Industriestraße 11, 96317 Kronach  
Telephone: + 49 (0)9261 / 99-0  
Fax: + 49 (0)9261 / 99-500  
E-mail: [ccc@loewe.de](mailto:ccc@loewe.de)

Trade Register: Municipal Court Coburg, No. HRB 42243  
VAT ID-No.: DE 193216550  
WEEE registration no.: DE 41359413

Issue 06.08 5th edition  
© Loewe Opta GmbH, Kronach  
All rights reserved including translation.  
Design and technical specifications are subject to change without notice.

# Language Code List

Enter the appropriate code when first setting up “Disk Audio”, “Disk Subtitles” and/or “Disk Menu”. (Further information can be found under “Disk Languages” on page 28.)

| <b>Code</b> | <b>Language</b> | <b>Code</b> | <b>Language</b> | <b>Code</b> | <b>Language</b> |
|-------------|-----------------|-------------|-----------------|-------------|-----------------|
| 6565        | Afar            | 7387        | Hebrew          | 8379        | Somali          |
| 6566        | Abkhaz          | 7465        | Japanese        | 8381        | Albanian        |
| 6570        | Afrikaans       | 7473        | Yiddish         | 8382        | Serbian         |
| 6577        | Amharic         | 7487        | Javanese        | 8385        | Sudanese        |
| 6582        | Arabic          | 7565        | Georgian        | 8386        | Swedish         |
| 6583        | Assamese        | 7575        | Kazakh          | 8387        | Swahili         |
| 6588        | Aymara          | 7576        | Greenlandic     | 8465        | Tamil           |
| 6590        | Azerbaijani     | 7577        | Cambodian       | 8469        | Telugu          |
| 6665        | Bashkir         | 7578        | Canadian        | 8471        | Tadzhik         |
| 6669        | Byelorussian    | 7579        | Korean          | 8472        | Thai            |
| 6671        | Bulgarian       | 7583        | Kashmiri        | 8473        | Tigrinya        |
| 6672        | Bihari          | 7585        | Kurdish         | 8475        | Turkmen         |
| 6678        | Bengali; Bangla | 7589        | Kirgiz          | 8476        | Tagalog         |
| 6679        | Tibetan         | 7665        | Latin           | 8479        | Tongan          |
| 6682        | Breton          | 7678        | Lingala         | 8482        | Turkish         |
| 6765        | Catalan         | 7679        | Laotian         | 8484        | Tatar           |
| 6779        | Corsican        | 7684        | Lithuanian      | 8487        | Twi             |
| 6783        | Czech           | 7686        | Latvian         | 8575        | Ukrainian       |
| 6789        | Welsh           | 7771        | Malagasy        | 8582        | Urdu            |
| 6865        | Danish          | 7773        | Maori           | 8590        | Uzbek           |
| 6869        | German          | 7775        | Macedonian      | 8673        | Vietnamese      |
| 6890        | Bhutanese       | 7776        | Malayalam       | 8679        | Volapuk         |
| 6976        | Greek           | 7778        | Mongolian       | 8779        | Wolof           |
| 6978        | English         | 7779        | Moldovian       | 8872        | Xhosa           |
| 6979        | Esperanto       | 7782        | Marathi         | 8979        | Yoruba          |
| 6983        | Spanish         | 7783        | Malay           | 9072        | Chinese         |
| 6984        | Estonian        | 7784        | Maltese         | 9085        | Zulu            |
| 6985        | Basque          | 7789        | Burmese         |             |                 |
| 7065        | Persian         | 7865        | Nauruan         |             |                 |
| 7073        | Finnish         | 7869        | Nepalese        |             |                 |
| 7074        | Fijian          | 7876        | Dutch           |             |                 |
| 7079        | Faroese         | 7879        | Norwegian       |             |                 |
| 7082        | French          | 7982        | Oriya           |             |                 |
| 7089        | Frisian         | 8065        | Punjabi         |             |                 |
| 7165        | Irish           | 8076        | Polish          |             |                 |
| 7168        | Scottish        | 8083        | Pashto          |             |                 |
|             | Gaelic          | 8084        | Portuguese      |             |                 |
| 7176        | Galician        | 8185        | Quechua         |             |                 |
| 7178        | Guarani         | 8277        | Romansh         |             |                 |
| 7185        | Gujarati        | 8279        | Romanian        |             |                 |
| 7265        | Hausa           | 8285        | Russian         |             |                 |
| 7273        | Hindi           | 8365        | Sanskrit        |             |                 |
| 7282        | Croatian        | 8368        | Sindhi          |             |                 |
| 7285        | Hungarian       | 8372        | Serbocroat      |             |                 |
| 7289        | Armenian        | 8373        | Singhalese      |             |                 |
| 7365        | Interlingua     | 8375        | Slovak          |             |                 |
| 7378        | Indonesian      | 8376        | Slovene         |             |                 |
| 7383        | Icelandic       | 8377        | Samoan          |             |                 |
| 7384        | Italian         | 8378        | Shona           |             |                 |

# List of country codes

Key in the corresponding code when first setting the “Area code” (page 31).

| Code | Country code             | Code | Country code                     | Code | Country code                             | Code | Country code              |
|------|--------------------------|------|----------------------------------|------|--|------|---------------------------|
| AD   | Andorra                  | CV   | Cape Verde                       | HU   | Hungary                                  | MS   | Montserrat                |
| AE   | United Arab Emirates     | CX   | Christmas Islands                | ID   | Indonesia                                | MT   | Malta                     |
| AF   | Afghanistan              | CY   | Cyprus                           | IE   | Ireland                                  | MU   | Mauritius                 |
| AG   | Antigua and Barbuda      | CZ   | Czech Republic                   | IL   | Israel                                   | MV   | Maldives                  |
| AI   | Anguilla                 | DE   | Germany                          | IN   | India                                    | MW   | Malawi                    |
| AL   | Albania                  | DJ   | Djibouti                         | IO   | British Territory<br>in the Indian Ocean | MX   | Mexico                    |
| AM   | Armenia                  | DK   | Denmark                          | IQ   | Iraq                                     | MY   | Malaysia                  |
| AN   | Dutch Antilles           | DM   | Dominica                         | IR   | Iran                                     | MZ   | Mozambique                |
| AO   | Angola                   | DO   | Dominican Republic               | IS   | Iceland                                  | NA   | Namibia                   |
| AQ   | Antarctic                | DZ   | Algeria                          | IT   | Italy                                    | NC   | New Caledonia (French)    |
| AR   | Argentina                | EC   | Ecuador                          | JM   | Jamaica                                  | NE   | Niger                     |
| AS   | American Samoa           | EE   | Estonia                          | JO   | Jordan                                   | NF   | Norfolk Island            |
| AT   | Austria                  | EG   | Egypt                            | JP   | Japan                                    | NG   | Nigeria                   |
| AU   | Australia                | EH   | West Sahara                      | KE   | Kenya                                    | NI   | Nicaragua                 |
| AW   | Aruba                    | ER   | Eritrea                          | KG   | Kirghizia                                | NL   | Netherlands               |
| AZ   | Azerbaijan               | ES   | Spain                            | KH   | Cambodia                                 | NO   | Norway                    |
| BA   | Bosnia-Herzegovina       | ET   | Ethiopia                         | KI   | Kiribati                                 | NP   | Nepal                     |
| BB   | Barbados                 | FI   | Finland                          | KM   | Comoros                                  | NR   | Nauru                     |
| BD   | Bangladesh               | FJ   | Fiji                             | KN   | Saint Kitts and Nevis Anguilla           | NU   | Niue                      |
| BE   | Belgium                  | FK   | Falkland Islands                 | KP   | North Korea                              | NZ   | New Zealand               |
| BF   | Burkina Faso             | FM   | Micronesia                       | KR   | South Korea                              | OM   | Oman                      |
| BG   | Bulgaria                 | FO   | Faroe Islands                    | KW   | Kuwait                                   | PA   | Panama                    |
| BH   | Bahrain                  | FR   | France                           | KY   | Cayman Islands                           | PE   | Peru                      |
| BI   | Burundi                  | FX   | France (European<br>Territory)   | KZ   | Kazakhstan                               | PF   | Polynesia (French)        |
| BJ   | Benin                    | GA   | Gabon                            | LA   | Laos                                     | PG   | Papua New Guinea          |
| BM   | Bermuda                  | GB   | Great Britain                    | LB   | Lebanon                                  | PH   | Philippines               |
| BN   | Brunei Darussalam        | GD   | Grenada                          | LC   | Saint Lucia                              | PK   | Pakistan                  |
| BO   | Bolivia                  | GE   | Georgia                          | LI   | Liechtenstein                            | PL   | Poland                    |
| BR   | Brazil                   | GF   | French Guyana                    | LK   | Sri Lanka                                | PM   | Saint Pierre and Miquelon |
| BS   | Bahamas                  | GH   | Ghana                            | LR   | Liberia                                  | PN   | Pitcairn Island           |
| BT   | Bhutan                   | GI   | Gibraltar                        | LS   | Lesotho                                  | PR   | Puerto Rico               |
| BV   | Bouvet Island            | GL   | Greenland                        | LT   | Lithuania                                | PT   | Portugal                  |
| BW   | Botswana                 | GM   | Gambia                           | LU   | Luxembourg                               | PW   | Palau                     |
| BY   | Byelorussia              | GN   | Guinea                           | LV   | Latvia                                   | PY   | Paraguay                  |
| BZ   | Belize                   | GP   | Guadeloupe (French)              | LY   | Libya                                    | QA   | Qatar                     |
| CA   | Canada                   | GQ   | Equatorial Guinea                | MA   | Morocco                                  | RE   | Reunion (French)          |
| CC   | Cocos (Keeling) Islands  | GR   | Greece                           | MC   | Monacco                                  | RO   | Rumania                   |
| CF   | Central African Republic | GS   | S. Georgia & S. Sandwich Islands | MD   | Moldova                                  | RU   | Russian Federation        |
| CG   | Congo                    | GT   | Guatemala                        | MG   | Madagascar                               | RW   | Rwanda                    |
| CH   | Switzerland              | GU   | Guam (USA)                       | MH   | Marshall Islands                         | SA   | Saudi Arabia              |
| CI   | Ivory Coast              | GW   | Guinea Bissau                    | MK   | Macedonia                                |      |                           |
| CK   | Cook Islands             | GY   | Guyana                           | ML   | Mali                                     |      |                           |
| CL   | Chile                    | HK   | Hong Kong                        | MM   | Myanmar                                  |      |                           |
| CM   | Cameroon                 | HM   | Heard and McDonald<br>Islands    | MN   | Mongolia                                 |      |                           |
| CN   | China                    | HN   | Honduras                         | MO   | Macao                                    |      |                           |
| CO   | Columbia                 | HR   | Croatia                          | MP   | Northern Mariana Islands                 |      |                           |
| CR   | Costa Rica               | HT   | Haiti                            | MQ   | Martinique (French)                      |      |                           |
| CS   | Former Czechoslovakia    |      |                                  | MR   | Mauretania                               |      |                           |
| CU   | Cuba                     |      |                                  |      |  |      |                           |

# Service

**(A)**

Loewe Austria GmbH  
Parking 12  
1010 Wien, Österreich  
Tel +43 - 1 22 88 633 - 0  
Fax +43 - 1 22 88 633 - 90  
Email loewe@loewe.co.at

**(AUS)**

International Dynamics  
Australasia Pty Ltd.  
129 Palmer Street  
Richmond 3121, Victoria,  
Australia  
Tel +61 - 3 - 94 29 08 22  
Fax +61 - 3 - 94 29 08 33  
Email mail@international  
dynamics.com.au

**(B NL L)**

Loewe Opta Benelux NV/SA  
Uilenbaan 84  
2160 Antwerpen, België  
Tel +32 - 3 - 2 70 99 30  
Fax +32 - 3 - 2 71 01 08  
Email ccc@loewe.be

**(BG)**

Darlington Service  
Kn. Klementina Street, bl. 193  
1618 Sofia, Bulgaria  
Tel +359 - 2 955 63 99  
Fax +359 - 2 955 63 99  
Email sac@audio-bg.com

**(CH)**

Telion AG  
Rütistrasse 26  
8952 Schlieren, Schweiz  
Tel +41 - 44 732 15 11  
Fax +41 - 44 732 15 02  
Email lgelpke@telion.ch

**(CY)**

HADJIKYRIAKOS & SONS LTD.  
121 Prodomos Str., P.O Box  
21587  
1511 Nicosia, Cyprus  
Tel +357 - 22 87 21 11  
Fax +357 - 22 66 33 91  
Email savvas@hadjikyriakos.  
com.cy

**(CZ)**

K+B PROGRES A.S.  
U Expertu 91  
25069 Klicany u Prahy, Česko  
Tel +420 2 72 12 21 11 (222)  
Fax +420 2 72 12 22 39  
Email loewe@kbexpert.cz

**(D)**

Loewe Opta GmbH,  
Customer Care Center  
Industriestraße 11  
96317 Kronach, Deutschland  
Tel +49 1801-22256393  
Fax +49 9261-99500  
Email ccc@loewe.de

**(DK)**

Kjaerulff 1 A/S  
C.F. Tietgens Boulevard 19  
5220 Odense SØ, Denmark  
Tel +45 - 66 13 54 80  
Fax +45 - 66 13 54 10  
Email mail@kjaerulff1.com

**(E)**

Gaplasa S.A.  
Conde de Torroja, 25  
28022 Madrid, España  
Tel +34 - 917 48 29 60  
Fax +34 - 913 29 16 75  
Email loewe@maygap.com

**(EST)**

TEDRA TRADING OY  
Kuusemetsa 3  
Saue 76506, Estonia  
Tel +372 - 50 14 817  
Fax +372 - 67 09 611  
Email raivo@futurehifi.com

**(F)**

Loewe Opta France S.A.  
13 rue du Dépôt,  
Parc del l'Europe, BP 10010  
67014 Strasbourg Cédex, France  
Tel +33 - 3 - 88 79 72 50  
Fax +33 - 3 - 88 79 72 59  
Email loewe.france@wanadoo.fr

**(FIN)**

Kjaerulff 1 OY  
Uudenmaantie 100  
20760 Piispansilta, Finland  
Tel +358 - 20 751 3800  
Fax +358 - 20 751 3801  
Email loewetuki@kjaerulff1.com

**(GB)**

Loewe UK Limited  
Century Court, Riverside Way  
Riverside Business Park, Irvine,  
Ayrshire  
KA11 5DD, UK  
Tel +44 - 1294 315 000  
Fax +44 - 1294 315 001  
Email enquiries@loewe-uk.com

**(GR)**

ISSAGOGIKI EMBORIKI ELLADOS  
S.A.  
321 Mesogion Av.  
152 31 Chalandri-Athens, Hellas  
Tel +30 - 210 672 12 00  
Fax +30 - 210 674 02 04  
Email christina@bose-onkyo.gr

**(H)**

Basys Magyarorszag KFT  
Tó park u.9.  
2045 Törökbálint, Magyar  
Tel +36 - 2341 56 37 (121)  
Fax +36 - 23 41 51 82  
Email basys@mail.basys.hu

**(HR)**

Plug&Play  
Bednjanska 8, 10000 Zagreb  
Hrvatska (Kroatia)  
Tel +385 1 4929 683  
Fax +385 1 4929 682  
Email loewe@loewe.hr

**(I)**

Loewe Italiana SRL  
Largo del Perlar, 12  
37135 Verona (VR), Italia  
Tel +39 - 045 82 51 611  
Fax +39 - 045 82 51 622  
Email Stefano.Borgognoni@  
loewe.it

**(IL)**

PL Trading (pz 2004) Ltd.  
27, Aliat Hanoar St.  
Givataim 53401, Israel  
Tel +972 - 3 - 57 27 155  
Fax +972 - 3 - 57 27 150  
Email zeev@loewe.co.il

**(IRL)**

Origo Ltd  
Unit 23 Magna Drive  
Magna Business Park, City West  
Dublin 24, Republic of Ireland  
Tel +353-1-4666700  
Fax +353-1-4666706  
Email service@origo.ie

**(KSA)**

SAS  
Hamad Al Haqueel Street,  
Rawdah, Jeddah  
Kingdom of Saudi Arabia  
Tel +966 (2) 665 4616 ext: 666  
Fax +966 (2) 660 7864  
Email hrant@sas-syseng.com

**(LT)**

A Cappella  
Ausros Vartu 5, Pasazo skg.  
01129 Vilnius, Lithuania  
Tel +370 - 52 12 22 96  
Fax +370 - 52 62 66 81  
Email: aretas@acappella.lt

**(M)**

DONEO CO. LTD  
34/36 Danny Cremona Street  
Hamrun, HMR02, Malta  
Tel +356 - 21 - 22 53 81  
Fax +356 - 21 - 23 07 35  
Email info@doneo.com.mt

**(MA)**

SOMARA S.A.  
377, Rue Mustapha El Maani  
20000 Casablanca, Morocco  
Tel +212 - 22 22 03 08  
Fax +212 - 22 26 00 06  
Email somara@somara.ma

**(N)**

CableCom AS  
Ostre Kullerød 5  
3241 Sandefjord, Norge  
Tel +47 - 33 48 33 48  
Fax +47 - 33 44 60 44  
Email odd@cablecom.no

**(NZ)**

International Dynamics (NZ) Pty  
Ltd  
PO Box 109 317, Newmarket  
Auckland, New Zealand  
Tel +64 9 379 0179  
Fax +64 9 379 0279  
Email: enquiries@international  
dynamics.co.nz

**(P)**

Mayro Magnetics Portugal, Lda.  
Rua Professor Henrique de Barros  
Edifício Sagres, 2º. C  
2685-338 Prior Velho, Portugal  
Tel +351 - 21 942 78 30  
Fax +351 - 21 942 78 30  
Email geral.loewe@mayro.pt

**(PL)**

DSV TRADING SA  
Plac Kaszubski 8  
81-350 Gdynia, Polska  
Tel +48 - 58 - 6 61 28 00  
Fax +48 - 58 - 6 61 44 70  
Email market@dsv.com.pl

**(RO)**

Avitech Co. SRL  
1/II Pipera Tunari St.  
007190 Voluntari, Ilfov, Romania  
Tel +40 - 21 200 64 64  
Fax +40 - 21 200 64 65  
Email andrei.silisteanu@avitech.ro

**(RUS)**

Service Center Loewe  
ul. Verkhnyaya Maslovka, d. 29  
125083 Moscow, Россия  
Tel +7 - 495 612 50 43  
Fax +7 - 495 612 47 10  
Email service@atc.ru

**(S)**

Kjaerulff 1 AB  
Ridbanegatan 4, Box 9076  
200 39 Malmö, Sverige  
Tel +46 - 4 06 79 74 00  
Fax +46 - 4 06 79 74 01  
Email Sweden@kjaerulff1.com

**(SK)**

BaSys Czech & Slovak s.r.o.  
Ostre Kullerød 17/A  
831 04 Bratislava, Slovakia  
Tel +421 2 49 10 66 18  
Fax +421 2 49 10 66 33  
Email: loewe@basys.sk

**(TR)**

ENKAY ELEKTRONIK SAN. Ve Tic.  
Ltd. Sti.  
Alemdag Cad: Site Yolu No.: 10  
81230 Ümraniye/ Istanbul, Türkiye  
Tel +90 - 216 634 44 44  
Fax +90 - 216 634 39 88  
Email mhatipog@enkaygroup.com

**(UAE)**

Dubai Audio Center  
P.O. Box 32836, Sheik Zayed Road  
Dubai, UAE  
Tel +971 - 4 343 14 41  
Fax +971 - 4 343 77 48  
Email dacdubai@emirates.net.ae

**(ZA)**

THE SOUNDLAB (PTY) LTD  
P.O. Box 31952, Kyalami 1684  
Republic of South Africa  
Tel +27 - 1 14 66 47 00  
Fax +27 - 1 14 66 42 85  
Email loewe@mad.co.za

# Glossary

## A

**AV socket:** Audio and video signal.

**AV sources:** Audio/video source.

**AVS:** Audio/video front sockets on the TV set (cinch and Mini-DIN).

## C

**Cinch cable:** Cable for transmitting sound or picture.

**Component Signal:** Video signal which is transmitted by three separate cinch connections. It is made up of the brightness signal "Y" and the colour difference signals "Pb" and "Pr". YPbPr is the original analogue version of the digital YcbCr in which the video data stored on the DVD are colour coded.

## D

**Digital Link:** System for controlling recorders (for Loewe video recorders and DVD recorders) via the Euro AV sockets of the Loewe TV set when installed in a concealed place. Control of the recorder for timer recordings.

**Digital Link Plus:** System for controlling recorders according to protocol 50. Station and timer data are transmitted to the recorder via the Euro AV socket for analog stations. The time recording is made exclusively by the recorder. Different names at different manufacturers.

**DTS:** Digital multi-channel sound.

**Dolby Digital:** Digital multi-channel sound.

**Dolby Pro Logic:** Analog multi-channel sound.

**Dolby Surround:** is an analog multi-channel sound system which accommodates four audio channels in two sound tracks using a matrix coding.

**DVD:** abbreviation for Digital Video Disk and later Digital Versatile Disk.

**DVD-Preceiver:** combi-device of DVD player and radio.

**DVI:** Digital Visual Interface is an interface for transmitting digital video and graphic data (without sound).

## E

**Euro AV socket:** Interface for connecting video recorders to a TV set. This socket is also known as a Scart socket.

## F

**Finalising:** Finishing the disc for playing on other players.

## H

**HDCP:** Copy protection standard.

**HDMI:** High Definition Multimedia Interface is a newly developed interface for full digital transmission of audio and video data.

## I

**Initialising:** Preparing the disc for recording video signals.

## L

**LCD:** Liquid Crystal Display.

**L-Link:** Interface for detection and control of Loewe audio components.

## M

**MPEG:** Digital compression method for video.

**Modulator:** Transmitter in the recorder to receive signals via the TV tuner.

**Mono:** single channel sound.

## N

**NICAM:** Sound standard NICAM is used in Belgium, Denmark, England, France, Sweden and Spain.

**NTSC:** American color standard.

## P

**PAL:** European colour standard.

**PCM:** Puls Code Modulation for digital sound.

**PIP:** Picture in Picture, a function which shows two pictures on one screen.

**Progressive Scan:** Technique for setting up images with real full images for flicker-free display.

**Picture In Picture:** see PIP.

## R

**RGB:** colour signals red, green, blue.

## S

**Switching voltage:** Video devices transmit this voltage to switch the TV to play.

**SECAM:** French colour standard.

**SetTop-Box:** (STB) Accessory connected to the TV set which enables additional functions.

**Signal strength:** strength of the reception signal.

**Signal quality:** quality of the incoming signal.

**Stereo:** dual channel sound.

## T

**Terrestrial:** In data transmission, a radio transmission which does not use a satellite as an intermediate station is called terrestrial.

**Tuner:** receiver.

## U

**USB:** Universal Serial Bus. Serial bus system for connecting external devices (USB card reader, USB stick).

## V

**VPS:** The Video Program System (VPS) is a signal which some (but not all) stations transmit in the scanning gap of the TV signal. The signal serves for video or DVD recorders to react to differences in the starting time, postponements and overrunning of the planned transmission time when recording programs.

## Y

**Ycc/Ypp:** colour standard in Set-Top-Boxes.