

**M-AUDIO**

# **Studiophile™** **AV 20**



English  
**User Guide**

# Introduction

# 1

**T**hank you for choosing the Studiophile AV 20 professional desktop multimedia audio monitors. Top recording engineers and producers in studios around the world use M-Audio monitors. Now, with the Studiophile AV 20 monitors, you can enjoy the same professional standard of audio quality right on your desktop.

The Studiophile AV 20 has been designed and tested by veteran audio engineers to meet your needs in a desktop audio monitoring environment. Custom-tuned cabinets, optimized speaker design, and advanced crossover technology deliver the best sound you can get in monitors this size. Complete with magnetic shielding for desktop use, Studiophile AV 20 delivers great audio experiences from your music and multimedia applications. The Studiophile AV 20 monitor is self-powered, directly accepting a line-level signal from a variety of sources.

## What's in the Box?

# 2

Your Studiophile AV 20 box contains:

- Two Studiophile AV 20 speakers (Left and Right)
  - Left:** built-in amp and power supply; volume control; main RCA stereo input, and right channel signal output on the back
  - Right:** audio connection from left speaker on back
- One 1/8" stereo mini-to-RCA audio cable for use with the main inputs
- 2-conductor standard (keyed) power cable
- Tinned bare wire audio cable to send right channel audio to the right speaker (transparent color)
- Acoustic/traction pads for speakers
- Owner's manual

## *Studiophile AV 20 Features*

# 3



### **1. Woofer**

The woofer unit is 2" in diameter and is magnetically shielded to protect your computer video monitor from interference. It includes a high-temperature voice coil and 2" polypropylene treated paper cone. The woofer delivers balanced mid- and low-frequency response.

### **2. Tweeter**

By employing a specially developed 1" Mylar diaphragm with protective magnetic shielding, the tweeter can deliver an extremely natural response. It minimizes resonance by adapting a unique internal damping technology.

### **3. Bass Reflex Port**

The hole in the rear panel is a bass reflex port. It is designed to discharge very low frequency signals and enhance the overall bass response.

### **4. Enclosure**

Along with the other components, the Studiophile AV 20's enclosure plays an important role. In order to provide more stable performance, we used a special medium-density fiberboard (MDF) and unique interior reinforcement designed to absorb vibration and impact generated under extreme conditions. Additionally, our innovative speaker monitor cabinet includes carefully placed acoustic material that makes the Studiophile AV 20 sound much bigger than it is—resulting in a smooth, natural bass response.

### **5. Network & Power Amplifiers**

The power amplifiers and crossover network, for the Studiophile AV 20 are specially designed for this woofer and tweeter. The network distributes low-, mid-, and high-frequency audio signals to the proper components in order to minimize distortion and to achieve a balanced sound.

## Installation

## 4

English

Français

Deutsch

Español

Italiano

日本語

**F**or optimal performance of the Studiophile AV 20, please read the following directions carefully before installation.

### Precautions

**Connections:** Your Studiophile AV 20 monitors have a single pair of RCA inputs for use with a multitude of devices. Use the provided cable to connect your soundcard's 1/8" line output to the RCA inputs on your left speaker's back panel. If your soundcard or alternative audio playback device is equipped with a different type of output connector (e.g. RCA outputs on M-Audio Delta Audiophile 24/96), then you will need to purchase an adapter or a cable with male RCA connectors on one end, and the connector that matches your playback device on the other end.

**Correct Power Operation:** Since the Studiophile AV 20 contains amplifiers, it must be connected to a power outlet using the detachable AC cable that is provided. Before connecting power, please make sure that the On/Off switch on the back of the Studiophile AV 20 is set to the off position.

**WARNING!** - Use of improper voltage may result in hazardous conditions and/or damage to speaker components not covered by speaker warranty. Please make sure the voltage is set appropriately by checking the the position of the red "AC Select" switch on the back before powering on your speakers.

### Acoustic/Traction Pads

In order to minimize vibrations and maximize physical stability, we recommend you use the provided acoustic/traction pads on the bottoms of the Studiophile AV 20 monitors.

### Speaker Wire Connections ①

Use the transparent tinned bare wire cable included in the Studiophile AV 20 package to connect the Left and Right speakers via the red /black spring-clip terminals on the back of each speaker.



### Connecting to a Computer Sound Card or Other Audio Output Device ②

Before connecting the Studiophile AV 20 monitors, make sure the power from the computer or other output device has been turned off and the Studiophile AV 20 system is also turned off.

Connect the RCA input jacks to the corresponding output connectors of a computer sound card, portable music player, etc.

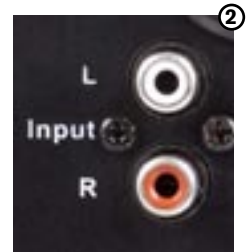

## Placing the Studiophile AV 20

# 5

**T**he way you position your speakers can greatly affect the way they sound. It is important to place your new reference monitors so that their tweeters are pointed directly towards your ears. Ordinary monitor speakers usually need to be elevated to ensure that their tweeters are level with the listener's ears. However, thanks to AV 20's unique curved front panel design, the ideal angle between tweeters and ears is achieved by simply placing them directly on the surface of your desk.

1. The two monitors and the listener should align to form an equilateral triangle.

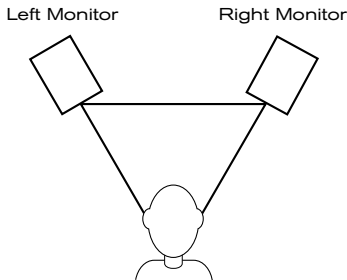

2. Place the monitors so that the tweeters point directly towards your ears.

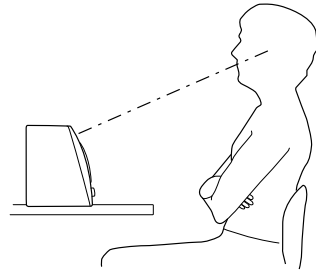

# Your Studiophile AV 20 Warranty

## 6

### Warranty Terms

M-Audio warrants products to be free from defects in materials and workmanship, under normal use and provided that the product is owned by the original, registered user.

Visit [www.m-audio.com/warranty](http://www.m-audio.com/warranty) for terms and limitations applying to your specific product.

### Warranty Registration

Immediately registering your new M-Audio product entitles you to full warranty coverage and helps M-Audio develop and manufacture the finest quality products available. Register online at [www.m-audio.com/register](http://www.m-audio.com/register) to receive FREE product updates and for the chance to win M-Audio giveaways.

## Appendices

## 7

### Appendix A - Block Diagram

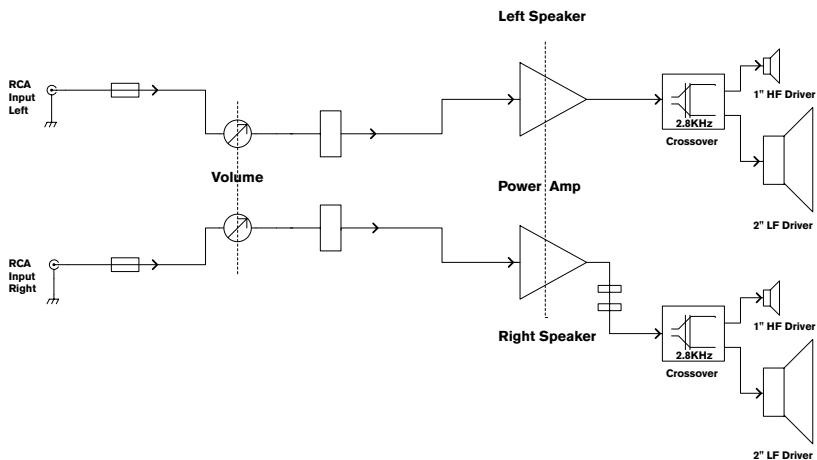

**Appendix B - Technical Specifications**

<b>Type:</b>	Two-way desktop reference monitor
<b>LF Driver:</b>	2" composite paper/fiberglass cone woofer, magnetically shielded
<b>HF Driver:</b>	1" ferro-fluid cooled, Mylar balanced-dome tweeter
<b>Frequency Response:</b>	120Hz-20KHz $\pm 3$ dB
<b>Crossover Frequency:</b>	2.8 kHz
<b>RMS SPL:</b>	90dB@1 meter
<b>S/N Ratio:</b>	>80dB typical A-weighted
<b>Input Connector:</b>	Left and right RCA Line input
<b>Polarity:</b>	Positive signal at + input produces outward low-frequency cone displacement
<b>Dynamic Power:</b>	10 watts into 4 ohms per channel, Class-D amplifier
<b>Input Impedance:</b>	10K ohms unbalanced
<b>Input Sensitivity:</b>	100mV pink noise input produces 84dBA output SPL at one meter with volume control at maximum
<b>Protection:</b>	RF interference, output current limiting, over temperature, turn on/off transient, subsonic filter
<b>Indicator:</b>	Blue power LED ring around volume knob on front panel
<b>Power Requirements:</b>	Factory programmed for either 100-120V~50/60Hz, 220-240V~50/60Hz
<b>Cabinet:</b>	Vinyl-laminated MDF
<b>Dimensions:</b>	7.8"(H) x 3.9"(W) x 6.16"(D)
<b>Weight:</b>	4.6kg

Specifications subject to change without notice

© 2006 Avid Technology, Inc. All rights reserved. Product features, specifications, system requirements and availability are subject to change without notice. Avid, M-Audio and Studiophile AV 20 are either trademarks or registered trademarks of Avid Technology, Inc. All other trademarks contained herein are the property of their respective owners.

<b>M-Audio USA</b> 5795 Martin Rd., Irwindale, CA 91706	
<b>Technical Support</b>	
web:	www.m-audio.com/tech
tel (pro products):	(626) 633-9055
tel (consumer products):	(626) 633-9066
fax (shipping):	(626) 633-9032
<b>Sales</b>	
e-mail:	sales@m-audio.com
tel:	1-866-657-6434
fax:	(626) 633-9070
<b>Web</b>	www.m-audio.com

<b>M-Audio U.K.</b> Floor 6, Gresham House, 53 Clarendon Road, Watford WD17 1LA, United Kingdom	
<b>Technical Support</b>	
e-mail:	support@maudio.co.uk
tel:(Mac support):	+44 (0)1765 650072
tel:(PC support):	+44 (0)1309 671301
<b>Sales</b>	
tel:	+44 (0)1923 204010
fax:	+44 (0)1923 204039
<b>Web</b>	www.maudio.co.uk

<b>M-Audio France</b> Floor 6, Gresham House, 53 Clarendon Road, Watford WD17 1LA, United Kingdom	
<b>Renseignements Commerciaux</b>	
tel :	0 810 001 105
e-mail :	info@m-audio.fr
<b>Assistance Technique</b>	
PC :	0 0820 000 731
MAC :	0 0820 391 191
<b>Assistance Technique</b>	
e-mail :	support@m-audio.fr mac@m-audio.fr
fax :	+33 (0)01 72 72 90 52
<b>Site Web</b>	www.m-audio.fr

<b>M-Audio Germany</b> Kuhallmand 34, D-74613 Ohringen, Germany	
<b>Technical Support</b>	
e-mail:	support@m-audio.de
tel:	+49 (0)7941 - 9870030
fax:	+49 (0)7941 98 70070
<b>Sales</b>	
e-mail:	info@m-audio.de
tel:	+49 (0)7941 98 7000
fax:	+49 (0)7941 98 70070
<b>Web</b>	www.m-audio.de

<b>M-Audio Canada</b> 1400 St-Jean Baptiste Ave. #150, Quebec City, Quebec G2E 5B7, Canada	
<b>Technical Support</b>	
email:	techcanada@m-audio.com
phone:	(418) 872-0444
fax:	(418) 872-0034
<b>Sales</b>	
e-mail:	infocanada@m-audio.com
phone:	(866) 872-0444
fax:	(418) 872-0034
<b>Web</b>	www.m-audio.ca

<b>M-Audio Japan</b> アビッドテクノロジー株式会社   エムオーディオ事業部 〒460-0002 愛知県名古屋市中区丸の内 2-18-10 Avid Technology K.K. 2-18-10 Marunouchi, Naka-Ku, Nagoya, Japan 460-0002	
<b>カスタマーサポート (Technical Support)</b>	
e-mail :	win-support@m-audio.jp
e-mail(Macintosh 環境専用):	mac-support@m-audio.jp
tel :	052-218-0859 (10:00~12:00/13:00~17:00)
<b>セールスに関するお問い合わせ (Sales)</b>	
e-mail:	info@m-audio.jp
tel:	052-218-3375
fax:	052-218-0875
<b>Web</b>	www.m-audio.jp