

User's Manual

# DIGITAL PIANO

---

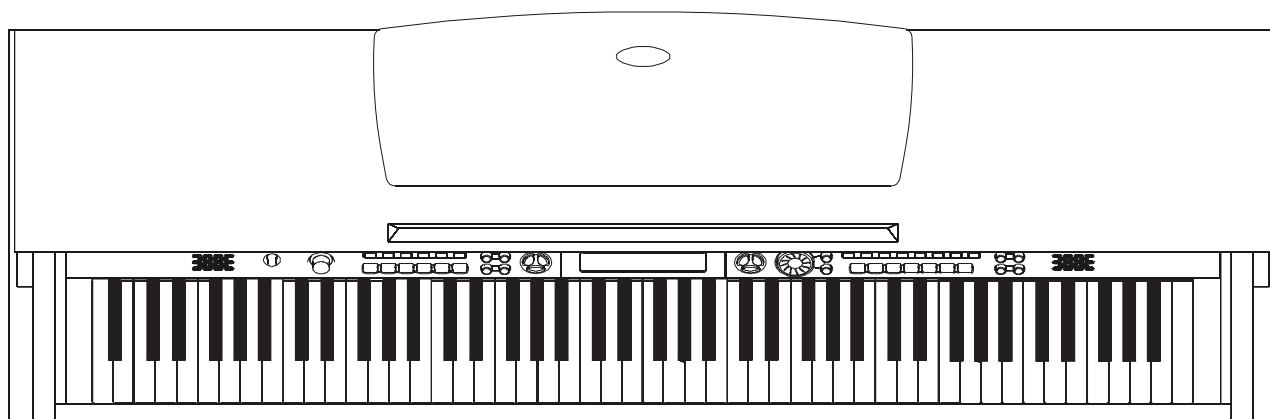

# Congratulations

Congratulation on your purchase of the professional digital piano.

This piano is an easy-to-use digital piano. Inside the slim cabinet, it has so many professional and modernized preset styles and songs, easy but powerful functions, and features that enhance your performance. Enjoy your performance with the piano!

You are recommended to study this manual carefully before using the unit.

## Inside This package

Please make sure the package completely contains the following:

- Piano Cabinet(including adapter cable)
- Right Side Panel
- Rear Panel
- Instruction Manual
- Left Side Panel
- Pedal Box(including pedal cable)
- Screw Bag



## Important Notes

Please read the following carefully before use:

- Do not expose the piano to high temperature, direct sunlight and excessively dusty places.
- Do not place the piano too close to other electrical appliances such as television and radio. It may cause interference.
- Do not place the piano to excessive humid area. Avoid putting container with liquid on top of the piano for preventing the damage of the internal parts of the piano by flowing liquid.
- Always unplug cables by gripping the plug firmly, but not pulling on the cable.
- Do not apply excessive force to the switches and buttons.
- When the piano is not in use or in the time of thunderstorm, please remember disconnect the power supply.
- Avoid adjusting the volume level to the maximum or to the levels that you feel uncomfortable, we recommend you to limit the volume level to two-third of the max to prevent the damage of auditory sense.
- Unplug the power cable before cleaning the piano, and do not connect or disconnect the power cable with a wet hand.
- Check and clean the power plug periodically.
- To avoid damage to the piano and other devices to which it is connected, turn the power switches of all related device off prior to connecting or disconnecting cables.
- Clean the piano with a dry soft cloth, a slightly damp cloth could be used to remove dirt as well.
- Never use cleaners such as thinner or alcohol. To prevent damage the surface of the LCD display, please use lens cleaning tissue to clean the display.
- If the piano cable is damaged, please do not use the piano. Otherwise it may cause fire or electrical hazard.
- In the case of malfunction due to improper handling the piano, please switch off and on again after 30 seconds.
- Do not attempt to disassemble or repair the piano by yourself, as well as the internal parts. If the piano does not work properly, please contact the approved repairer.

# Main Features

- **Keyboard:**  
88-keys touch response keyboard with 3 touch levels.
- **Display:**  
Multi-function LCD display.
- **Operation:**  
Friendly user-interface, using dial or add/sub button to select styles, songs and voices.
- **Voices:**  
210 voices. 16 voices can be selected by direct select button.
- **Styles:**  
120 styles. 12 styles can be selected by direct select button.
- **Songs:**  
60 songs (with Melody off functions).
- **Demo songs:**  
3 demo songs.
- **Chord:**  
Single-fingered detect and multi-fingered detect
- **Recording:**  
one user song.
- **Memory:**  
4 Banks, each has 4 Memories.
- **Styles controlling:**  
SYNC, START/STOP, FILL IN A/NORMAL, FILL IN B/VARIATION, INTRO/ENDING.
- **Other functions:**  
DUAL ,SPLIT ,O.T.S., METRONOME, TRANSPOSE, TUNING, BEAT, TOUCH, SPLIT ,DSP LEVEL, MIDI IN, MIDI OUT
- **Mixer:**  
Drum Volume, Bass Volume, Orchestra Volume, Voice R1 Volume, Voice R2 Volume, Voice L Volume.
- **Jacks:**
  1. USB jack.
  2. Head Phone jack.
  3. Audio output.
  4. Pedal jacks (sustain, soft, sostenuto).

## NOTE:

Hold down [ + ] and [ - ] buttons simultaneously then turn on the power, the piano will reset factory setting. You will lost all information that you set.

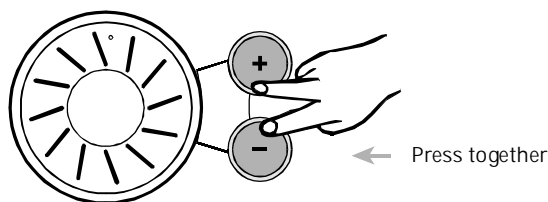

# Contents

Set-up Guide.....	6-8	Mixer.....	25
General Guide.....	9-10	Memory.....	26-27
The Connectors.....	11-12	- Memory Bank.....	26
- Using the AC power jack.....	11	- Store/Load Parameter.....	26
- Using headphones jack.....	11	- Memory Data.....	26
- Using AUX.OUT jack.....	11	- Clear Memory Data.....	27
- Using the foot pedals.....	12	One Touch Setting.....	27
- Using the USB jack.....	12	Record.....	28
Basic Operation.....	13	- Record Waiting.....	28
- Power Switch and Master Volume.....	10	- Start Record.....	28
- Demo.....	10	- Stop Record.....	28
Voice and Effects.....	14-15	- Playback Record.....	28
- Select a voice.....	14	Song.....	29
- Dual voice.....	14-15	Specifications.....	30
- Lower Voice/Split Point.....	15	Trouble shooting.....	30
Auto Accompaniment.....	16-22	Appendix 1-Voice List.....	31-32
- Select a style.....	16	Appendix 2-style list.....	33
- The Accompaniment Section.....	16	Appendix 3-Demo list.....	34
- Start the style.....	17	Appendix 4-Song list.....	34
- Fill A/B.....	18	Appendix 5-Chord chart.....	35
- Stop the style.....	18	Appendix 6-MIDI Implementation.....	36
- Accomp volume.....	19	Chart	
- Tempo.....	19		
- Chord Recognize.....	20-21		
- Metronome.....	22		
Function.....	22-24		
- Transpose.....	23		
- Tune.....	23		
- Beat.....	23		
- Touch.....	23		
- Split Point.....	24		
- DSP Level.....	24		
- MIDI IN Channel.....	24		
- MIDI OUT Channel.....	24		

# Set-up Guide

Before assembly, please make sure that all of the following items are present.

- 1. Piano Cabinet
- 2. Right Side Panel
- 3. Left Side panel
- 4. Big Rear Panel
- 5. Pedal Box
- 6. Screw(X4)

- 7. Screw  $\Phi 6 \times 30$ (X4)
- 8. Screw  $\Phi 4 \times 15$  (X5)
- 9. Adhesive Clamp(X2)
- 10. Power Supply Cable
- 11. Screw  $\Phi 6 \times 12$ (X2)
- 12. Pedal Cable

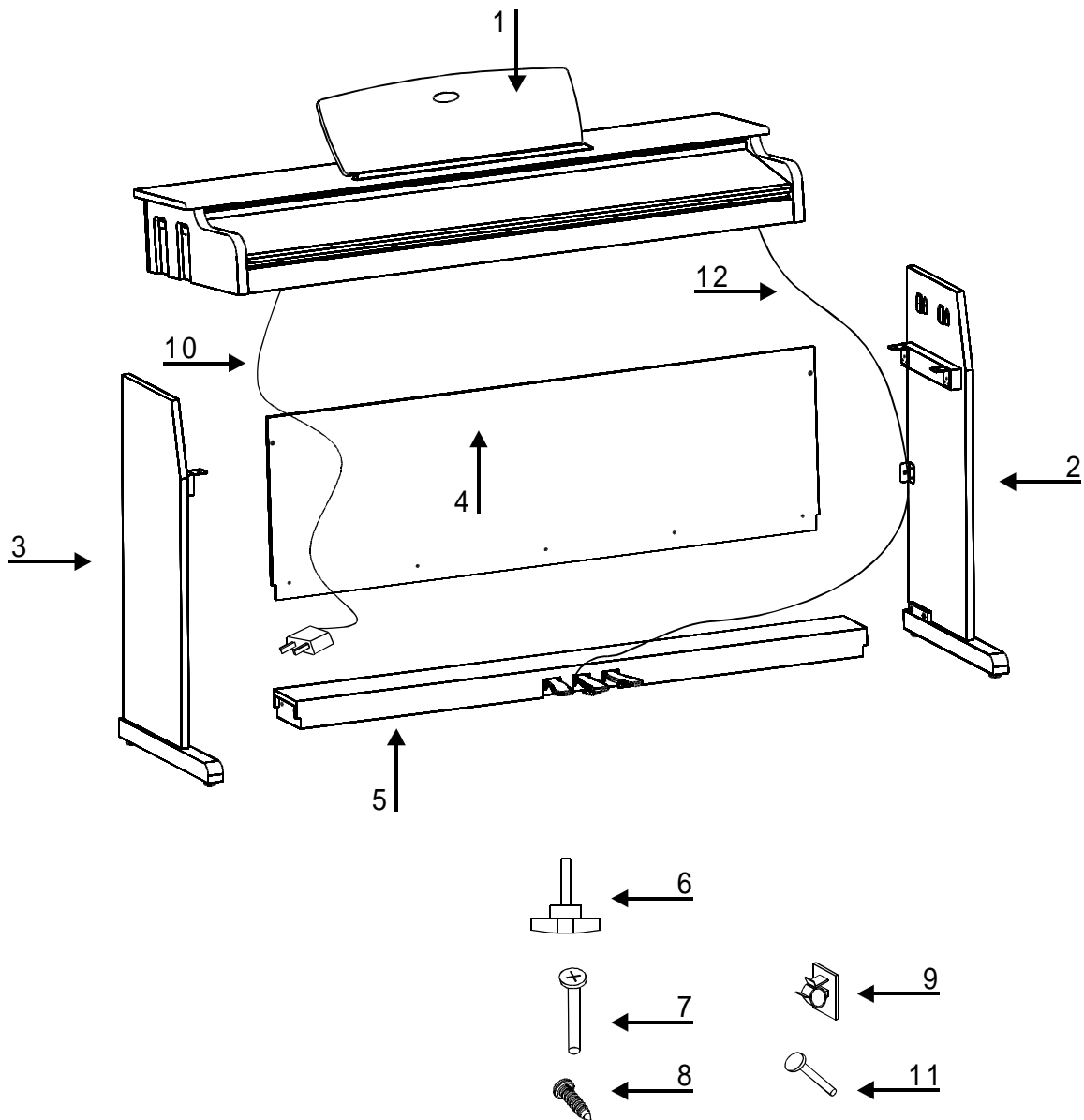

### Side Panel and Pedal Box assembly

Place the pedal box on the two side panels and then use screws to fasten the side panels.

- 7.Screws  $\Phi 6 \times 30 (X4)$

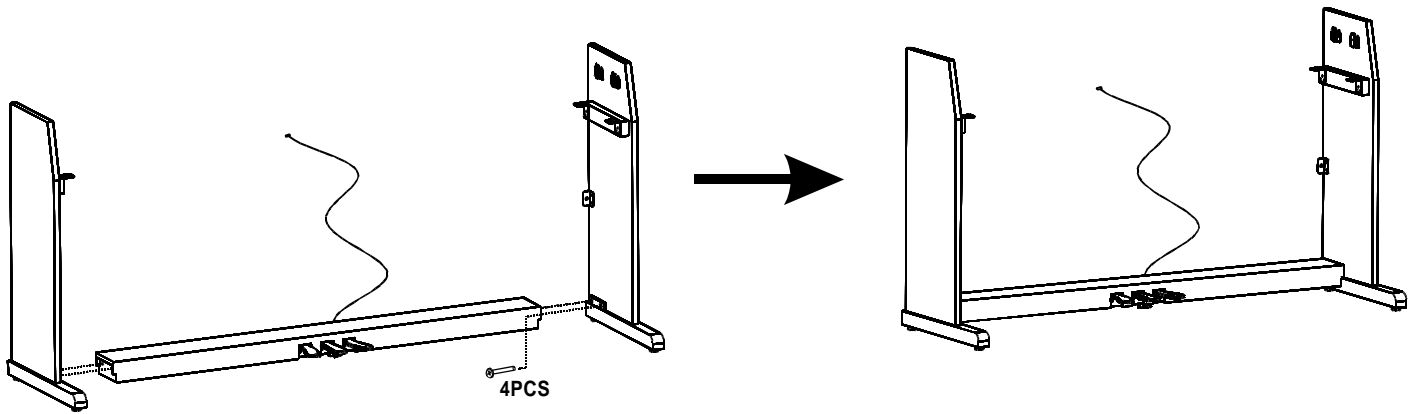

**NOTE:**  
Please use the screws that be supplied, do not use the other screws.

### Rear Panel assembly

Fix the rear panel to the side panels with 2 screws and to the bottom of the rear panel with 5 screws.

- 8. Screws  $\Phi 4 \times 15 (X5)$
- 11.Screws  $\Phi 6 \times 12 (X2)$

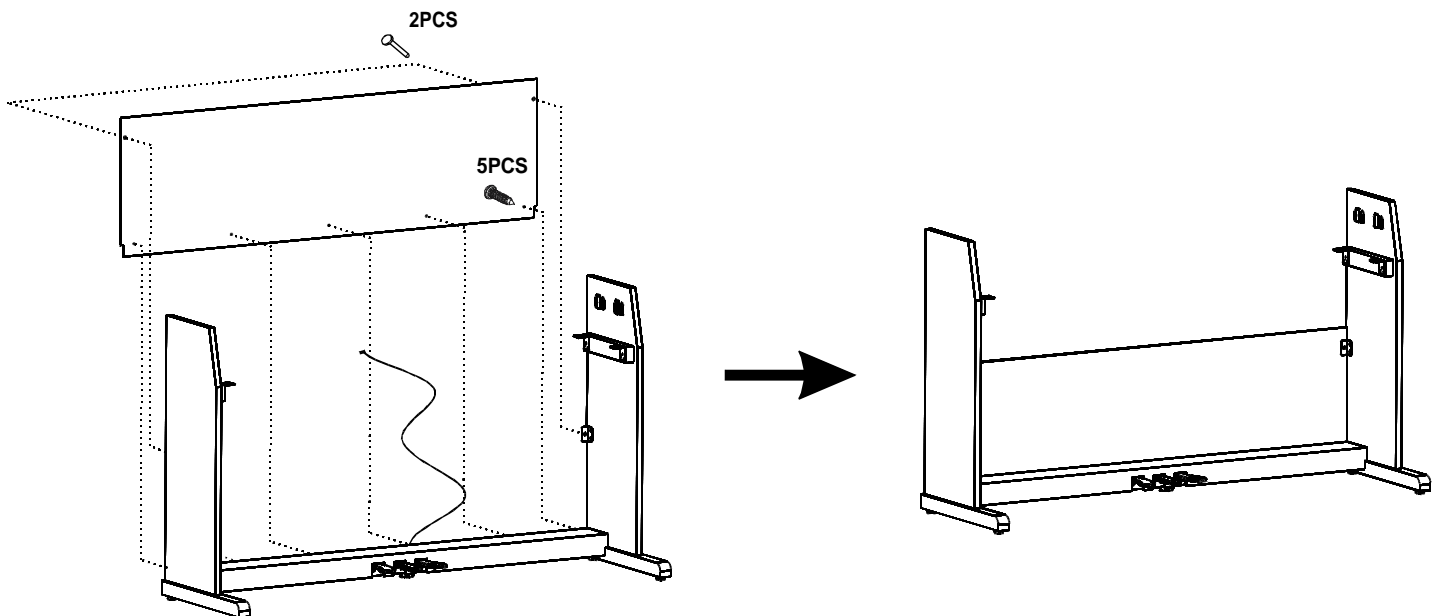

## Attach the Piano Cabinet

Place the piano cabinet on the stand, fix it using four screws.

■ 6.Screws (X4)

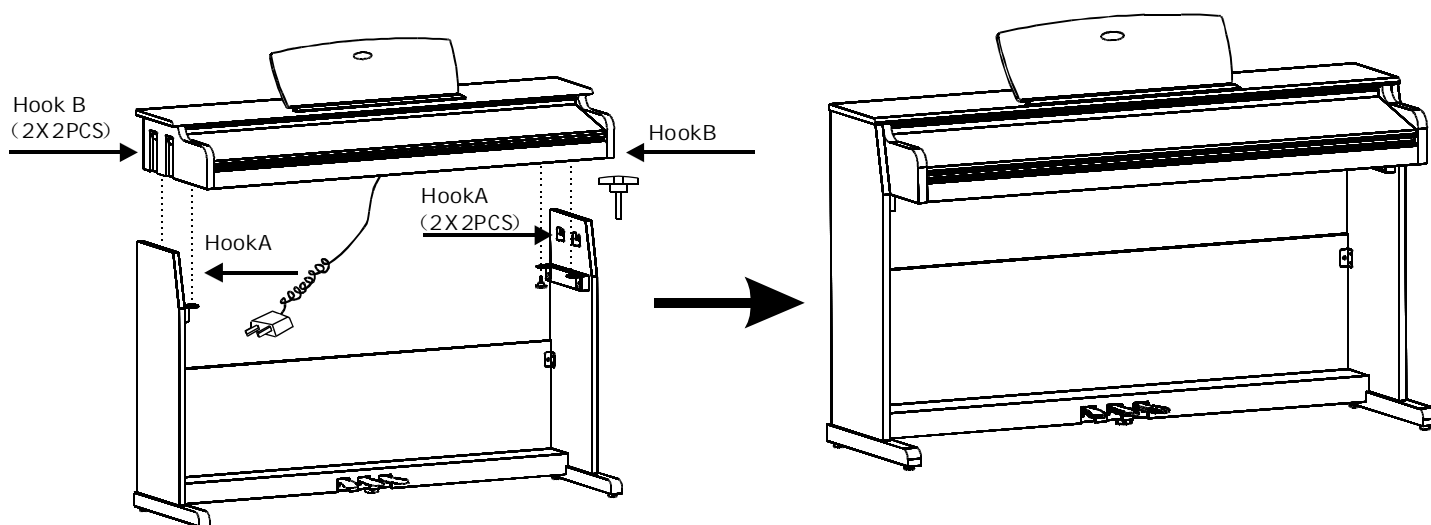

## Fix the cables

Attach 2 adhesive clamps on right and the left side panels to fix the cables.

Insert the DIN plug of pedal cable into the proper socket of cabinet.

Place the piano in its final location and adjust on floor the pedal clog under pedals group.

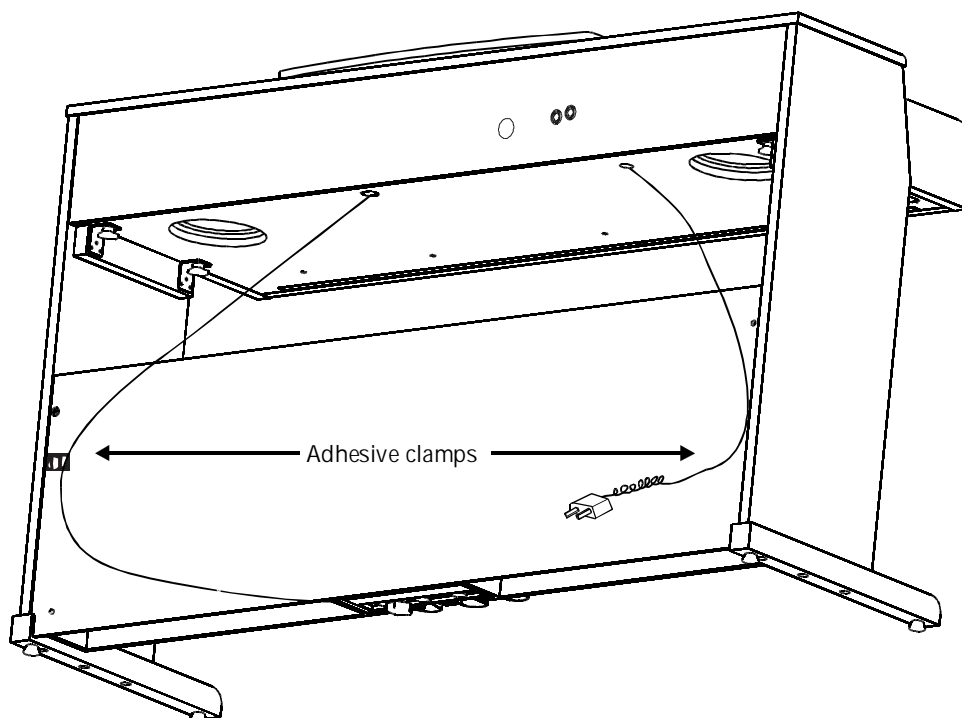

# General Guide

## Plane

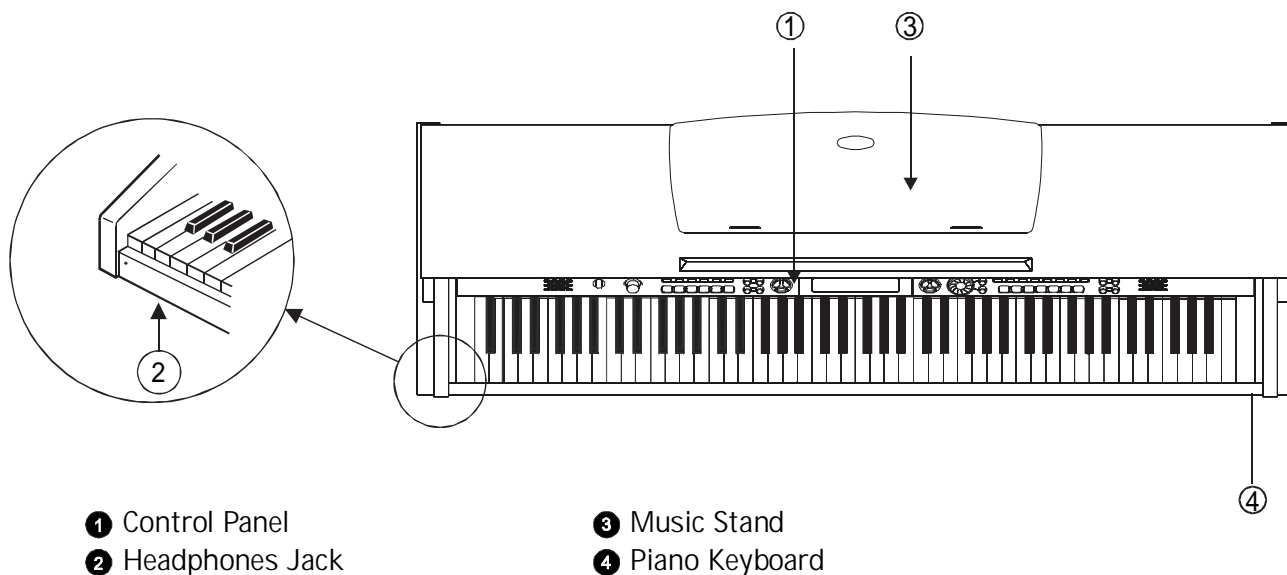

## Rear Panel

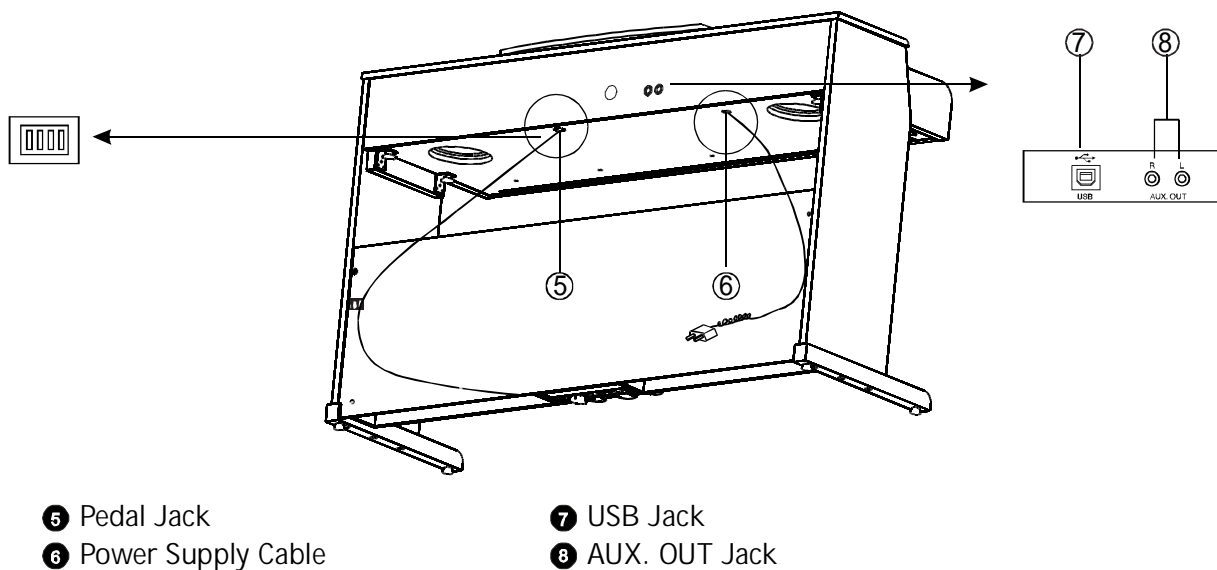

## Front Panel

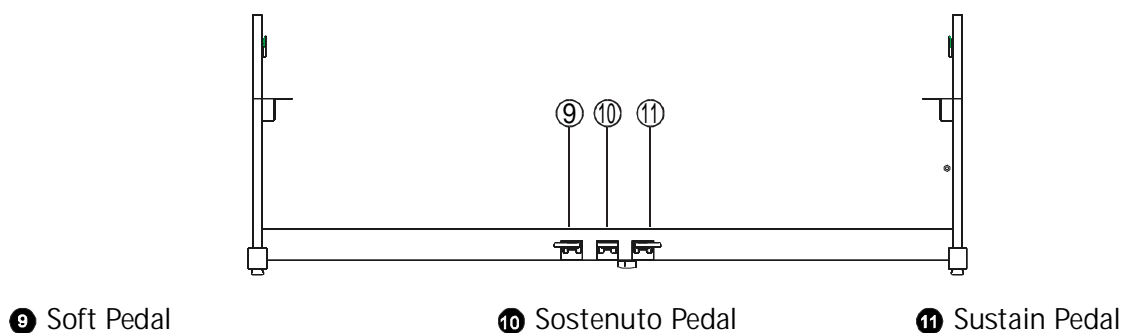

## Control Panel

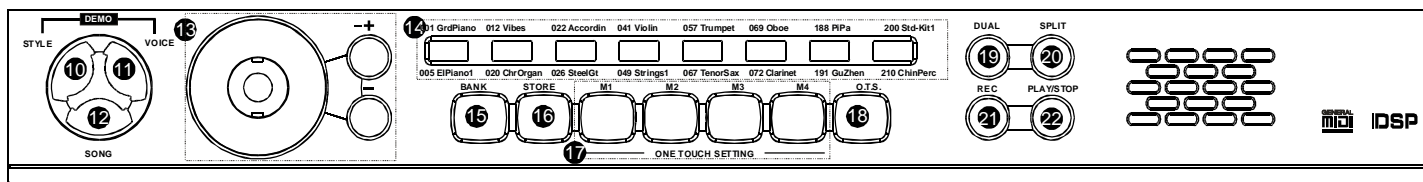
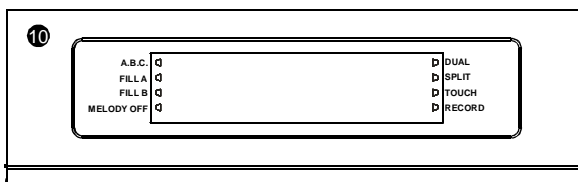
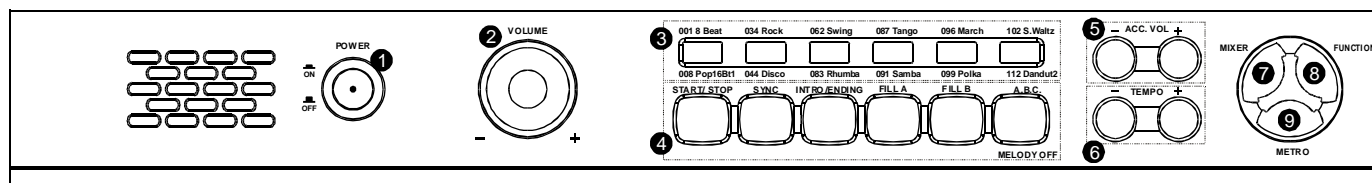

- 1 POWER SWITCH
- 2 MASTER VOLUME
- 3 STYLES DIRECT SELECT
- 4 STYLE MODE  
-START/STOP  
-SYNC  
-INTRO/ENDING  
-FILL A  
-FILL B  
-A.B.C.
- 5 ACCOMP VOLUME +/-
- 6 TEMPO +/-
- 7 MIXER
- 8 FUNCTION
- 9 METRONOME
- 10 STYLE
- 11 VOICE  
Press [STYLE], [VOICE] buttons  
simultaneously to play DEMO.
- 12 SONG
- 13 DIAL, +, -
- 14 VOICE DIRECT SELECT
- 15 BANK
- 16 STORE
- 17 ONE TOUCH SETTING (M1-M4)
- 18 ONE TOUCH SETTING
- 19 DUAL
- 20 LOWER
- 21 RECORD
- 22 PLAY/STOP

## LCD Display

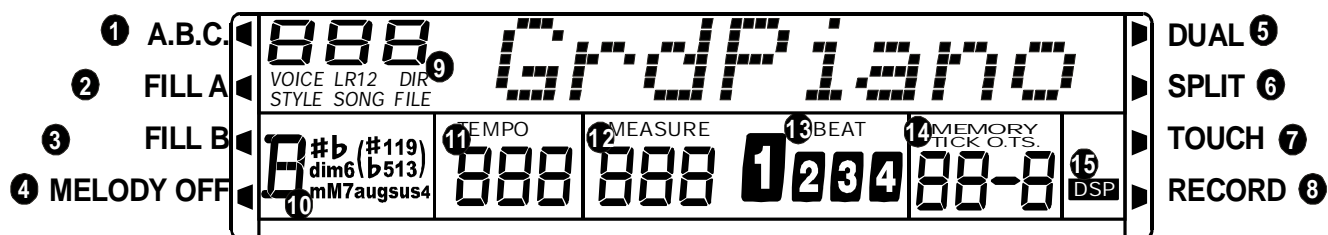

- 1 A.B.C
- 2 FILL A
- 3 FILL B
- 4 MELODY OFF
- 5 DUAL
- 6 SPLIT
- 7 TOUCH
- 8 RECORD
- 9 VOICE/STYLE/SONG/FORMAT/FILE
- 10 CHORD
- 11 TEMPO/VEL
- 12 MEASURE
- 13 BEAT
- 14 MEMORY/TICK/O.T.S.
- 15 DSP

# The Connectors

## Using the AC power jack

1. Ensure the piano is turned off when connecting and disconnecting the power.

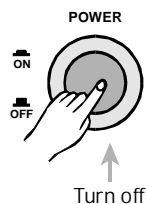

2. Turn the volume switch anti-clockwise to reach the minimum volume level.

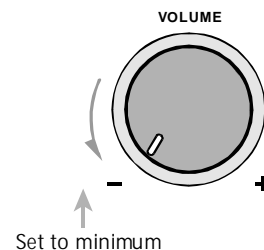

3. Plug the power cable into an AC power outlet.

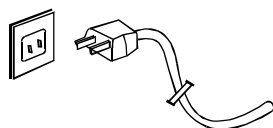

4. If you have done the above procedures you are now safe to turn on the piano.



### NOTE:

- When the piano is not in use or in the time of thunderstorm, please disconnect the power for safety sake.

## Using headphones jacks

There are two headphones jacks on the left underneath the piano body.

1. When an optional set of stereo headphones is connected with the headphones jack 2, the sound from speakers will switch off automatically resulting in only the sound from headphone to be heard.
2. When jack 1 is connected with the stereo headphones, the sound can be heard from both headphones and speakers of the piano.

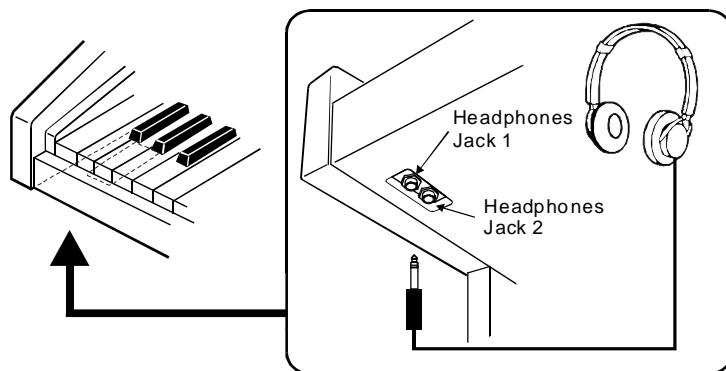

### NOTE:

- Never use the headphones with high volume, as it may hurt your ears.
- To prevent the damage of the speakers, ensure that the volume is set to the minimum level before connecting the power and other devices.

## Using the AUX.OUT jack

Connect the rear-panel AUX.OUT jack to amplified speakers, amplifiers or domestic hi-fi-units for external amplification.

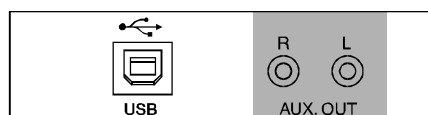

### NOTE:

- Connect both left(L) and right(R) channels for the stereo result. If you only connect either one of the channels, the connected channel will only take effect.

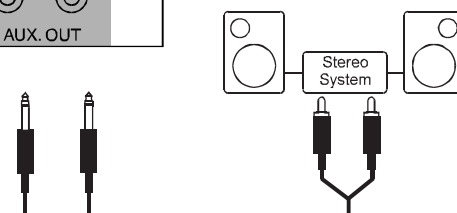

## Using the foot pedals

Connect the plug of the foot pedal unit to the pedal jack on the rear panel.

You will experience the sustain/soft/sostenuto effect.

### NOTE:

- When the sustain pedal is pressed, notes continue to play after their keys have been released. Releasing the pedal will silence the sustained notes.
- If you play a note on the keyboard and press the sostenuto pedal while the notes are held, those notes will still sustain as long as you hold the pedal. But all subsequently played notes will not be sustained.
- The soft pedal reduces the volume while the pedal is pressed. The soft pedal will not affect notes that are already playing when it is pressed.

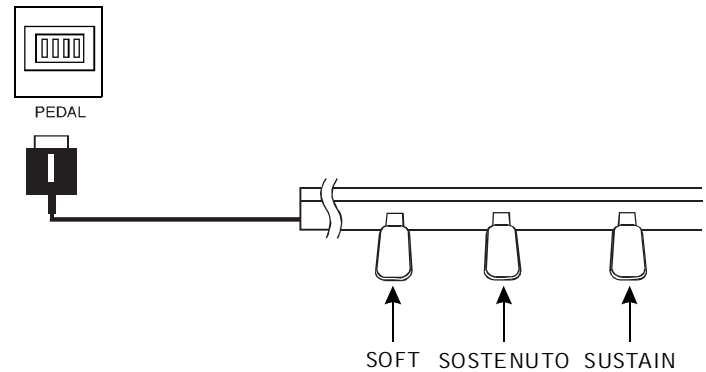

## Using the USB Jack

1. Connect PC or other USB host devices that support USB audio.

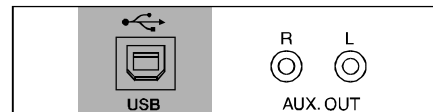

2. For devices with USB cable, you can simply connect the MIDI/USB converter to your USB connector on your devices and plug the MIDI in or MIDI out cables into the piano, after the driver is installed and initialization is finished, you can choose USB Audio Device in the device menu of the software to transfer midi data.

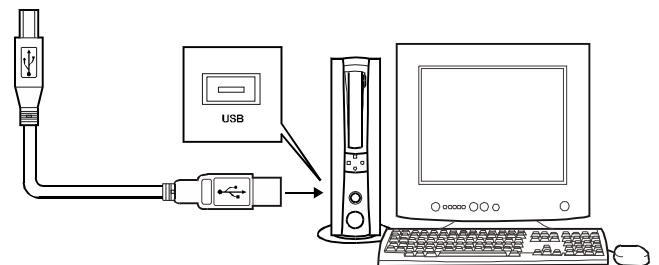

# Basic Operation

## Power Switch and Master Volume

1. First, make sure the correct connections.
2. Turn the [POWER] switch on. The LCD display lights up.
3. Use the [VOLUME] control switch to adjust the volume to your desired level.

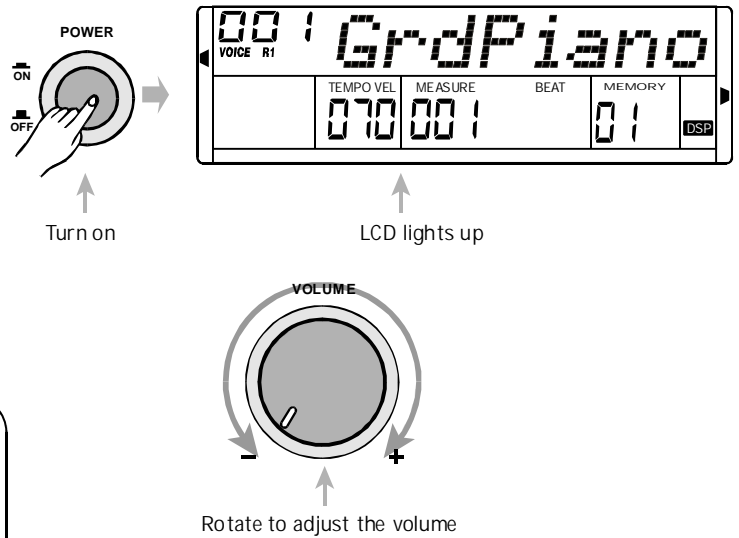

### NOTE:

- If the LCD display does not light up after you turned on the piano, please check the power supply.
- If the piano is silent, that means the volume has adjusted to its minimum level.

## Demo

There are total 3 demos. (See appendix)

1. Press [VOICE] & [STYLE] simultaneously to play demo song.

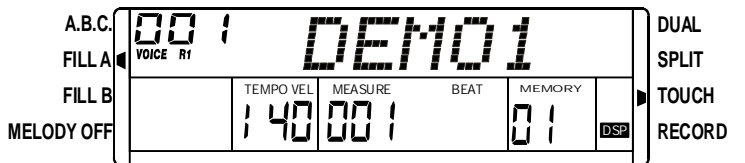
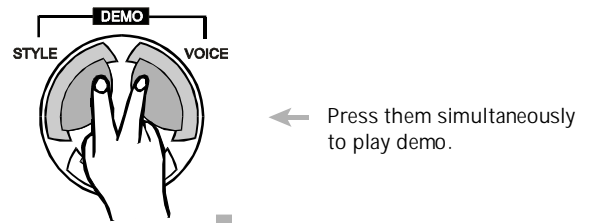

2. Press [+] / [-] or rotate the dial to select demo song number.

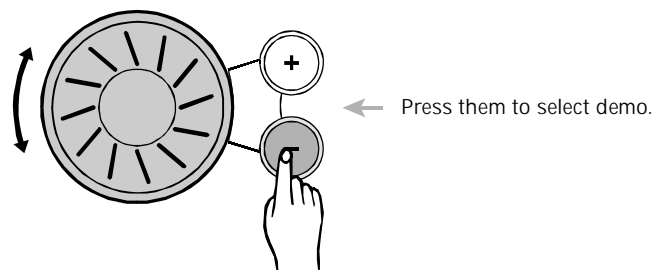

3. Press [VOICE] & [STYLE] simultaneously again or press [START/STOP] to stop playing.

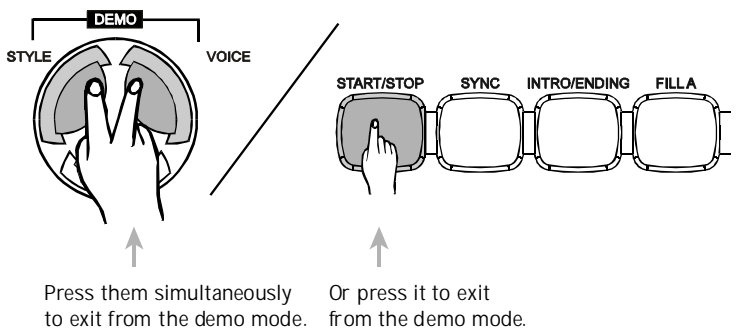

# Voices and Effects

There are 210 voices in total (see appendix).

## Select a Voice

1. When power on, the default VOICE R1 is No.001, the VOICE R1 flag lit up and the voice name appears on LCD.

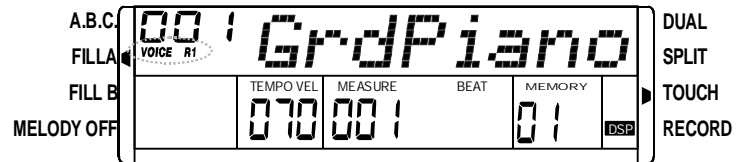

2. Press [VOICE] button to select three separate voice modes: VOICE R1, VOICE R2, VOICE L.

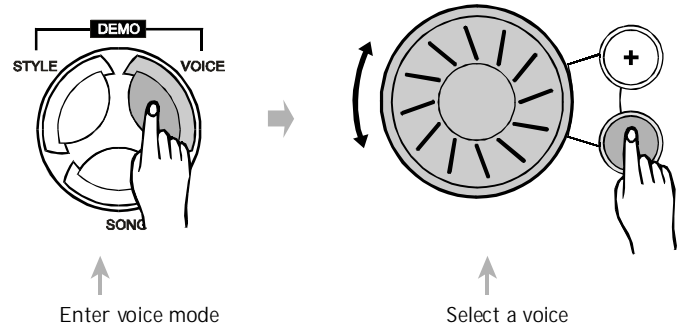

3. You can select the voice you wanted with [+] / [-] button or dial.

4. Use the 16 Voices Direct Select Button to select the voice with 2 direct voices in each button (upper & nether)

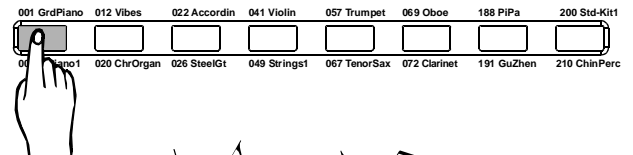

5. After selecting a voice, you can now play the piano.



### NOTE:

- While changing a voice, pay attention to the rules: If you press the same button, the voice will be changed between the upper and nether key.
- When the upper/nether voice is on, and then you press another direct button, the corresponding upper/nether voice will be selected.

## Dual Voice

The piano has dual voice. You can create the new sound through this function for richer and punchier sounds. It seems that you can get two different sounds at the same time when you press a key in the right area in the keyboard.

1. Press [DUAL] button to turn on the DUAL VOICE, "VOICE1" light off, "VOICE R2" and DUAL flag would both be displayed on LCD. The dual voice name is also displayed on LCD. Then, you will hear two different sounds at the same time when you press a key in the right area of the keyboard.

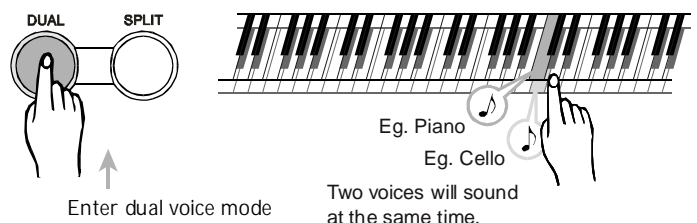
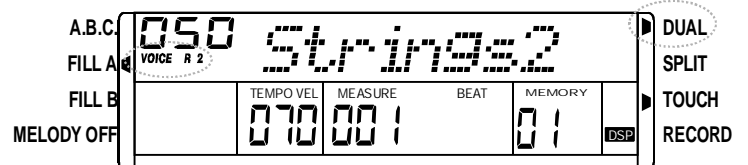

## Voices and Effect

- Press [+] / [-] button , or turn the dial to select the dual voice number. The default dual voice number is No. 50 Strings2.

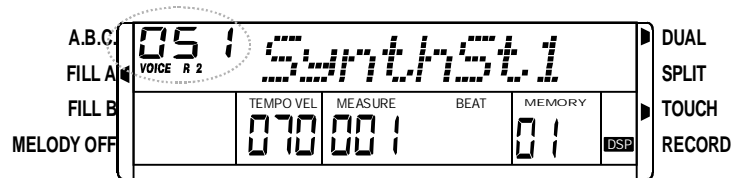
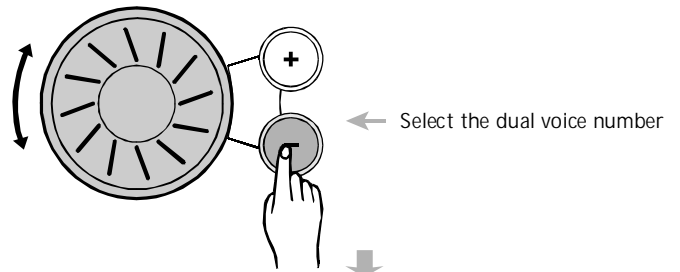

- Press [DUAL] button again to exit the DUAL VOICE mode.

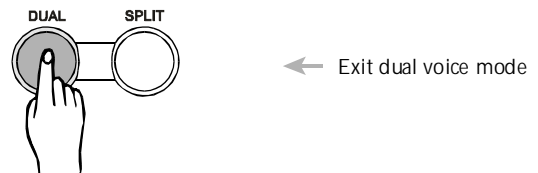

### NOTE:

- In DUAL VOICE status, only section above split point on the keyboard has dual voice.

## Lower Voice/Split Point

The piano has lower voice. You can split the keyboard to melody and chord area by this function.

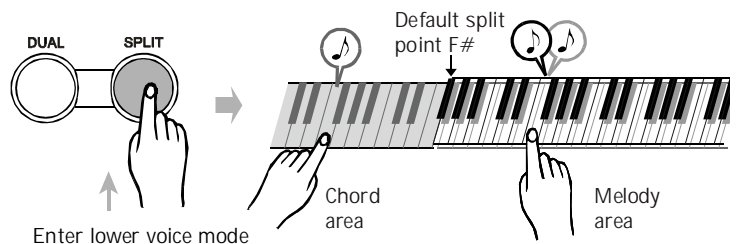

- Press [SPLIT] button to turn on the LOWER VOICE, the whole keyboard would be spitted into right and left areas. LCD lightens the LOWER voice flag and displays "VOICE L" and its name.

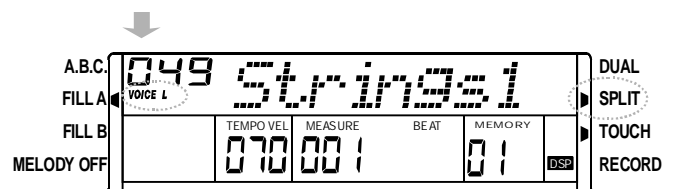

- Press [+] / [-] button to select the lower voice number. The default lower voice number is No. 49 Strings1.

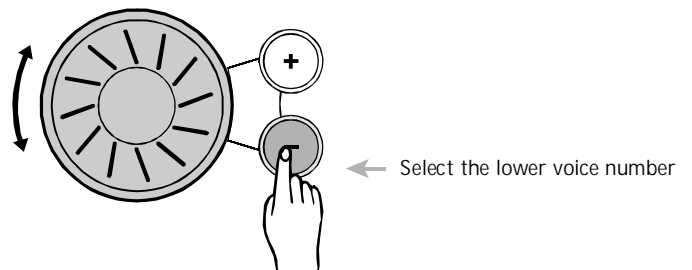

- Press [SPLIT] button again to exit the LOWER VOICE mode. LCD darkens the Lower voice flag.



# Auto Accompaniment

## Select a Style

There are 120 styles in total, from 001 to 120 (see appendix).

- When power on, the default style number is 001. Press [STYLE] button or style direct select button to enter the style mode, the STYLE flag is lit up and the name of style appears on LCD.
- You can press [+] / [-] button or dial to select the styles you want.
- Use the 6 Styles Direct Select Button to select the style with 2 direct styles in each button (upper & nether).
- After selecting a style, you can now play the piano.

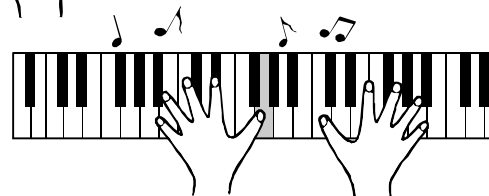
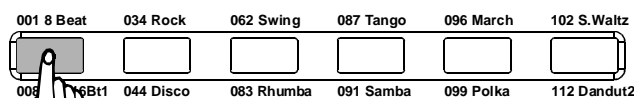
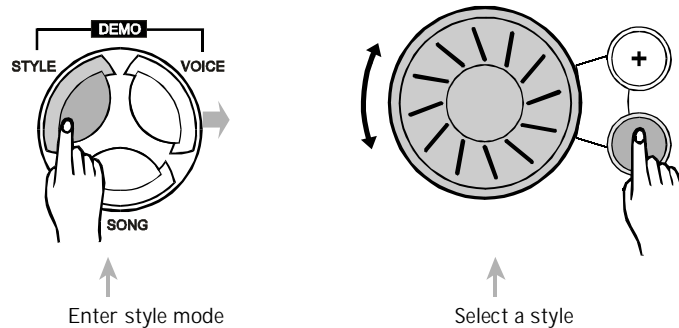
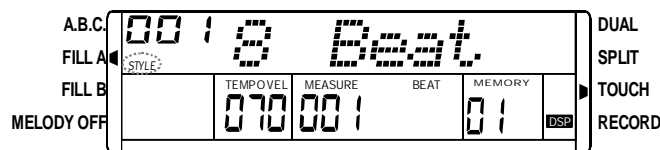

### NOTE:

- While changing a style, pay attention to the rules: If you press the same button twice, the style will be swapped from one to another.
- When the upper/nether voice is on, and then you press another direct button, the corresponding upper/nether voice will be selected.

## The Accompaniment Section

Accompaniment consists of INTRO, NORMAL, VARIATION, FILL, ENDING. Using different section based on the structure of songs enables you to enhance musical performance.

### 1. INTRO

Press the [INTRO/ENDING] button to insert an intro section before you start to play. The main section will be followed by the INTRO section.

### 2. NORMAL AND VARIATION

There are two main section: normal and variation. Each section consists of 2 to 4 measures.

### 3. FILL

While the accompaniment is playing, you can fill in the rhythm/accompaniment by pressing the [FILL A] button or the [FILL B] button. This will automatically insert a fill section.

### 4. ENDING

When you press the [INTRO/ENDING] button, it brings rhythm accompaniment and your performance to the end.

## Start the Style

### 1. Start immediately:

Press [START/STOP] button to start the style(only drum).

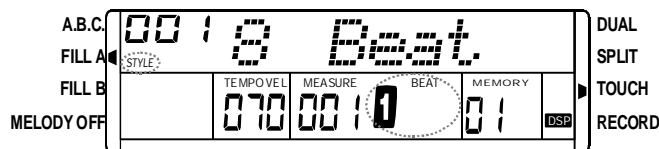
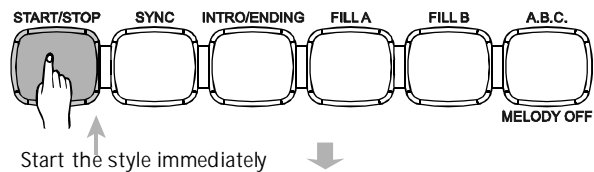

### 2. A.B.C. Mode:

The default setting of A.B.C. is off.

Press [A.B.C./MELODY OFF] button to turn on the auto bass chord. The A.B.C. icon will appear on the LCD.

The area to the left of split point is known as the chord area. When playing the chord, both the bass and the chord voice sound.

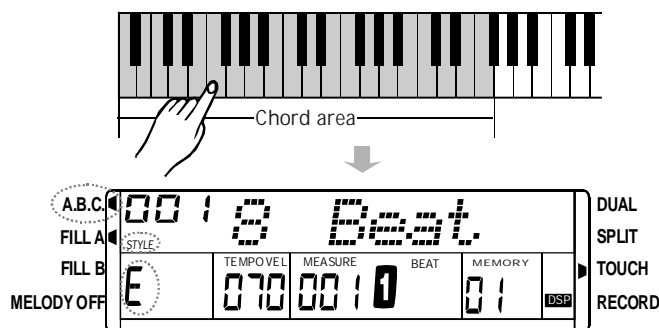
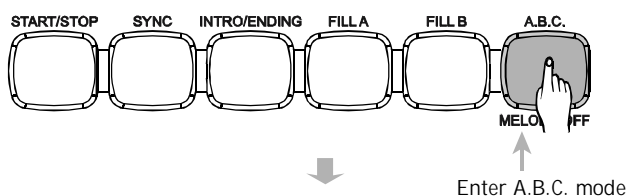

#### NOTE:

There are 2 ways to detect the chord: single finger detect and fingers detect.

- If the chord played according with fingers detect, it is recognized as the fingers chord.
- If not, single finger chord will be recognized.

### 3. Synchronous Start:

- Press the [SYNC] button to enters Sync start waiting mode, and the beat indicators on LCD will flash.

- If the A.B.C. mode is off, play any key on keyboard only start playing the style by drum voice.

- If the A.B.C mode is on, play any key in left area of keyboard will start playing the style.

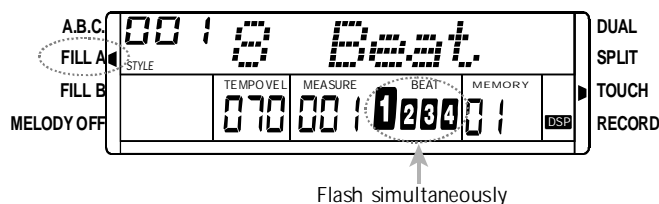
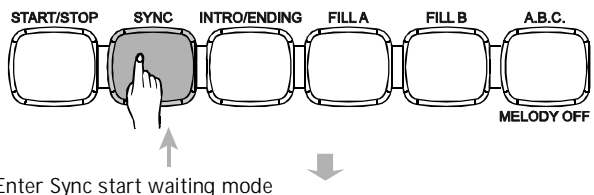

### 4. INTRO Start:

- Press [INTRO/ENDING] button to insert an intro section before you start to play the style.

- Press [START/STOP] button, then the normal or variation style will play after the intro style.

- Press [INTRO/ENDING] button when the style is playing, style will be stopped after the ending.

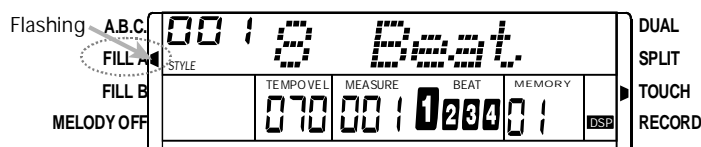
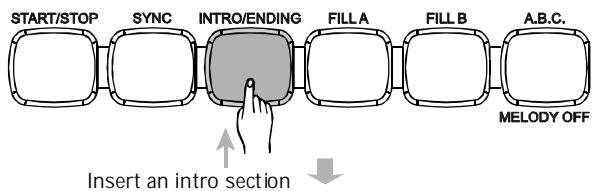

## FILL A/B

1、 In NORMAL mode, press [FILL A] button to insert 1 measure fill and LCD flashes 'FILL A'. After one measure is over, it will smoothly lead to NORMAL style.

2、 In NORMAL mode, press [FILL B] button to insert 1 measure fill and LCD flashes 'FILL B'. After one measure is over, it will smoothly lead to VARIATION style.

3、 In VARIATION mode, press [FILL A] button to insert 1 measure fill and LCD flashes 'FILL A', After one measure is over, it will smoothly lead to NORMAL style will be returned.

4、 In VARIATION mode, press [FILL B] button to insert 1 measure fill and LCD flashes 'FILL B', After one measure is over, it will smoothly lead to VARIATION style will be returned.

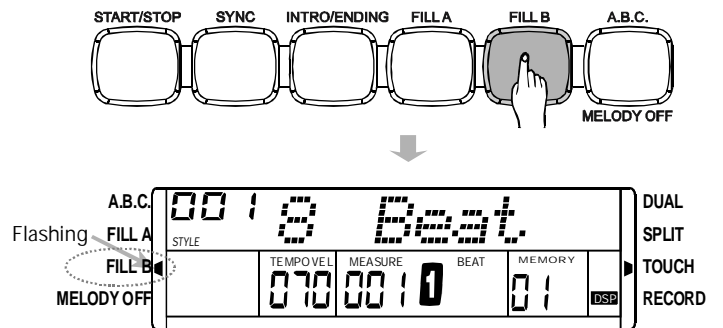
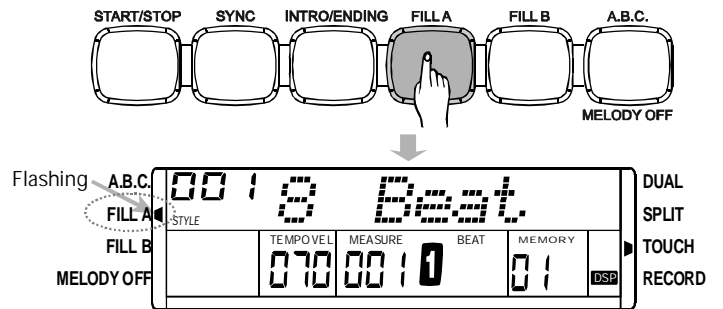

### NOTE:

- Press and hold down the [FILL A] or [FILL B] button when the style is playing, the selected FILL pattern repeats continuously until button is released.
- Press [FILL A] when style stop, it will change to the main section, the 'FILL A' flag on the LCD will be lightened.
- Press [FILL B], it will change to the variation section, the 'FILL B' flag on the LCD will be lightened.

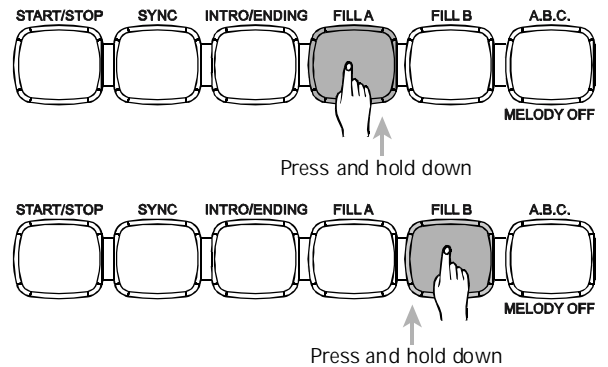

## Stop a Style

### 1、 Stop immediately:

The accompaniment can be stopped at any time by pressing the [START/STOP] button.

### 2、 Ending Stop:

Press the [INTRO/ENDING] button to complete the song with ending section. The ending section will begin from the top of the next measure.

### 3、 Sync Stop:

Press the [SYNC] button to stop playing, and the synchronized start mode will activated.

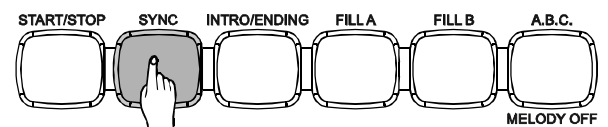
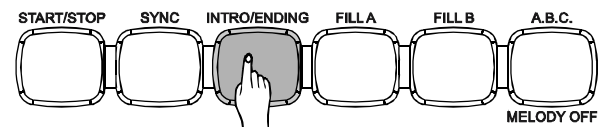
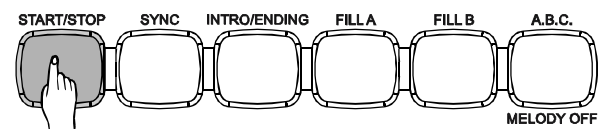

## Auto Accompaniment

### Accomp Volume

1、 You can change the general volume of style through Accompaniment volume adjustment.

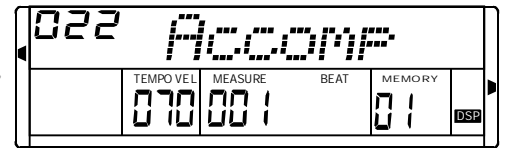
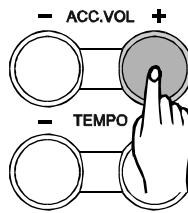

2、 Press the [ACCOMP+] / [ACCOMP-] button to adjust the volume.

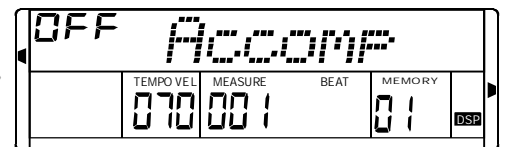
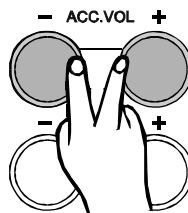

3、 When you press [ACCOMP+] and [ACCOMP-] together, the volume you are setting will turn off.

### Tempo

1、 Press the [TEMPO+] or [TEMPO-] button, the tempo value would be flashing for about 2 seconds.

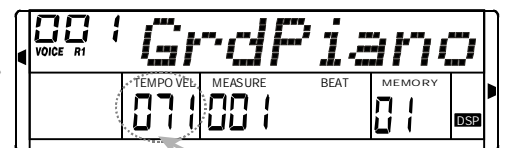
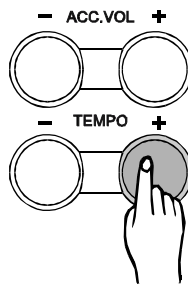

Flashing two seconds

2、 During that time, the tempo can be adjusted by dial with the range of 30—280.

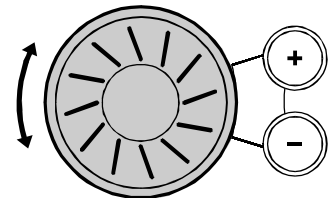
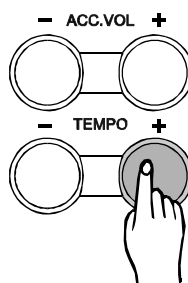

Press and hold on.

3、 Press and hold on the [TEMPO+] or [TEMPO-] button to adjust the tempo continuously.

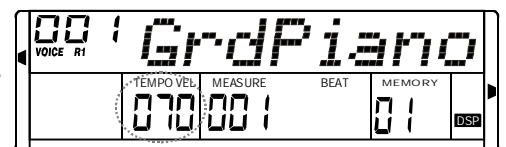
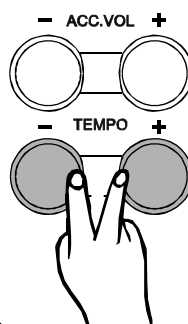

Press simultaneously

#### NOTE:

- The piano will not take out the default tempo of the style if you change the style when it is playing.

## Chord Recognize

"A.B.C." is disabled during the default setting. Press [A.B.C./MELODY OFF] button to turn on this "auto bass chord" function; the A.B.C. flag on the LCD is lightened. The left section of the keyboard is known as the "chord area", while playing the chord, both the bass and the chord voices phonate.

**NOTE:**

Since the chord detection of A.B.C. is based on the Chord Root priority, some chords that could be played under the Chord Dictionary may not be recognised by A.B.C. though, eg. B6, bB6, B6(9), bB6 ,9, Baug, bBaug, bBm6, Bm6, Adim7, bBdim7, Bdim.

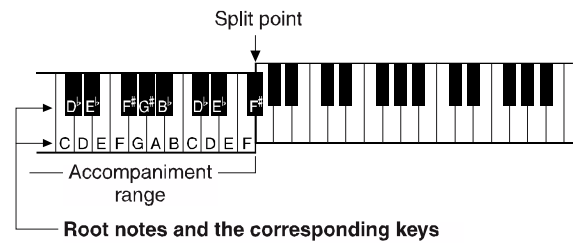
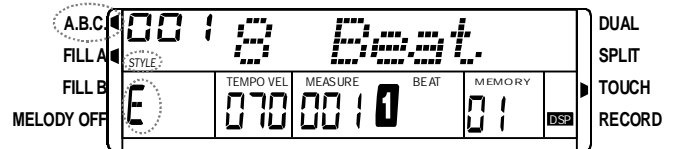
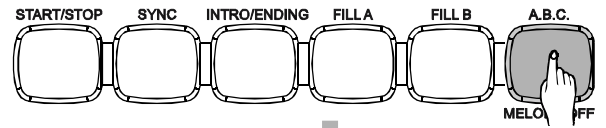

There are 2 ways to detect a chord: "single finger detect" and "multi fingers detect".

If the chord played is based on "multi fingers detect", it is recognized as the "multi fingers chord".

If not, "single finger chord" will be recognized.

- **Single Finger Chords**

This method allows you to play chords easily within the accompaniment range of the keyboard using only one, two, or three fingers.

Examples of Single Finger Chord are "C, Cm, C7 and Cm7", shown as below:

	• To play a major chord Press the root note of the chord
	• To play a minor chord Press the root note together with the nearest black key to the left of it .
	• To play a seventh chord Press the root note together with the nearest white key to the left of it .
	• To play a minor seventh chord Press the root notes together with the nearest white and black keys to the left of it (three keys altogether) .

**NOTE:**

When A.B.C. is on, press the keys on the left of the split point. The chord will be recognized as single finger chords.

- **Multi Finger Chords**

This method allows you to produce an accompaniment by playing chords with normal fingerings within the accompaniment range of the keyboard.

To play Multi Chords ( Example for C chords)

A total of 32 chords are provided as below:

0 C	1 C <sub>6</sub>	2 C <sub>M7</sub>	3 C <sub>M7</sub> (#11)	4 C <sub>M</sub> (9)	5 C <sub>M7</sub> ( <sup>9</sup> )
6 C <sub>6</sub> ( <sup>9</sup> )	7 C <sub>aug</sub>	8 C <sub>m</sub>	9 C <sub>m6</sub>	10 C <sub>m7</sub>	11 C <sub>m7</sub> (b5)
12 C <sub>m</sub> (9)	13 C <sub>m7</sub> ( <sup>9</sup> )	14 C <sub>m7</sub> ( <sup>11</sup> )	15 C <sub>m</sub> M <sub>7</sub>	16 C <sub>m</sub> M <sub>7</sub> ( <sup>9</sup> )	17 C <sub>dim</sub>
18 C <sub>dim7</sub>	19 C <sub>7</sub>	20 C <sub>7sus4</sub>	21 C <sub>7</sub> (b5)	22 C <sub>7</sub> ( <sup>9</sup> )	23 C <sub>7</sub> (#11)
24 C <sub>7</sub> (b13)	25 C <sub>7</sub> (b9)	26 C <sub>7</sub> ( <sup>13</sup> )	27 C <sub>7</sub> (#9)	28 C <sub>M7aug</sub>	29 C <sub>7aug</sub>
30 C <sub>sus4</sub>	31 C <sub>1+2+5</sub>	Notes enclosed in parentheses • are optional; the chords could be recognized without them.			

## • Chord Basics

Three or more notes played together constitute a "chord".

The most basic chord type is the "triad" consisting three notes: the root, third, and fifth degrees of the corresponding scale.

A "C major triad", for example, is made up of the notes C (the root), E (the third note of the C major scale), and G (the fifth note of the C major scale).

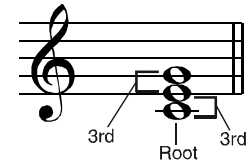

In the C major triad shown as above, the lowest note is the "root" of the chord (this is the chord's "root position"...using other chord notes for the lowest note results in "inversion"). The root is the central sound of the chord, which supports and anchors other chord notes.

The distance (interval) between adjacent notes of triad in root position is either a major or minor third.

Major third – four half steps (semitones)

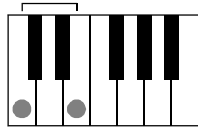

Minor third – three half steps (semitones)

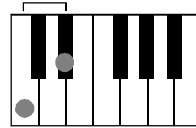

The lowest interval in our root-position triad (between the root and the third) determines whether the triad is a major or minor chord, and we can shift the highest note up or down by a semitone to produce two additional chords, as shown below.

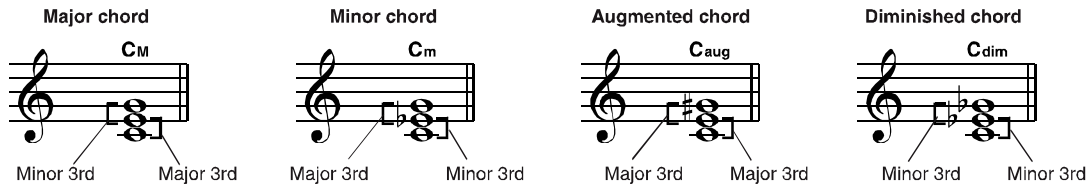

The basic characteristics of the chord sound remain intact even if we change the order of the notes to create different inversions. Successive chords in a chord progression can be smoothly connected, for example, by choosing the appropriate inversions (or chord "voicings").

## • Reading Chord Names

Chord names tell you just about everything you need to know about a chord (other than the inversion/voicing). The chord name tells you what the root of a chord is, whether it is a major, minor, or diminished, whether it requires a major or flatted seventh and what alterations or tension does it use...all at a glance.

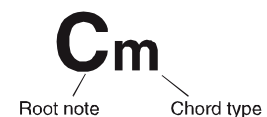

## • Some Chord Types

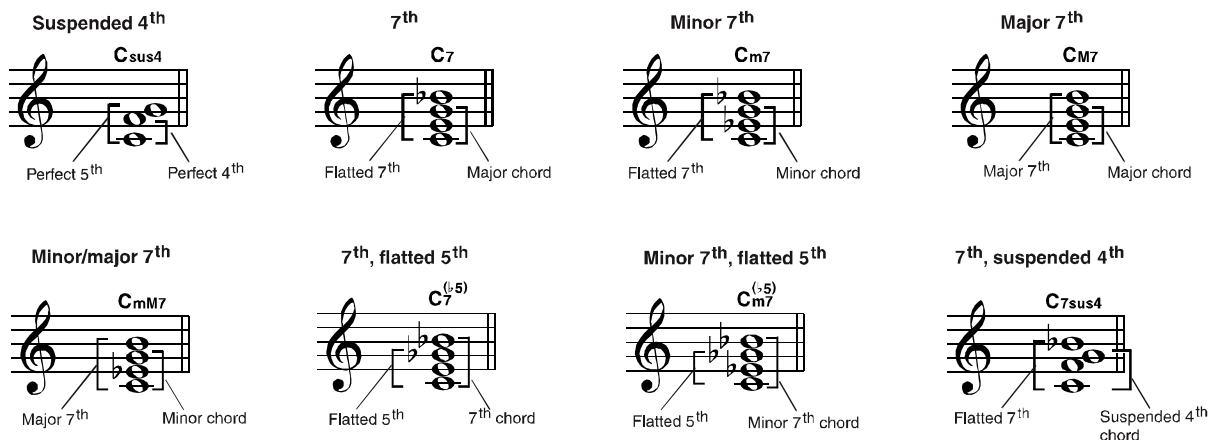

## METRONOME

1、 Press [METRO] button to turn on metronome and the metronome sound will be played.

2、 In the Function menu, you can adjust the beat with dial, [+]/[-]. The range is 0, 2~9. (See Function Operation).

3、 Press [METRO] button again, you will turn off the metronome.

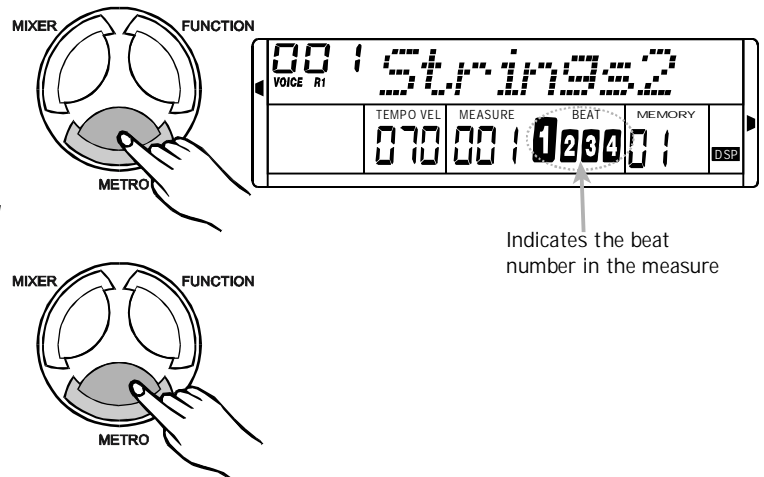

### NOTE:

- Metronome can be played in tempo with the accompaniment whenever you turn on the style.
- When stopping style, turn on the Metronome, the beat type will follow the measure.
- When playing style, turn on the Metronome, the metronome sound begins to respond in next section, the beat type will follow the style.
- If first turn on the Metronome, then play the style, the Metronome will automatically be set to match the tempo of the style, but you can also change the tempo yourself.

## Function

Press [FUNCTION] button to enter function menu. When power on, the first option of the menu is “Transpose” , Press [FUNCTION] button repeatedly to select function option, then press [+]/[-] or dial to adjust its parameter, see below table:

content	LCD Display	Range	Default Value
Transpose	Transpos	-12 — +12	0
Tune	Tune	-50 — 50	0
Beat	Beat	0, 2 — 9	4
Touch	Touch	OFF,1,2,3	2
Split point	Split pt	1 — 88	34(F3#)
DSP reverb level	DSPlevel	OFF 、 1 — 7	2
MIDI IN channel	Midi In	01 — 16 、 ALL	ALL
MIDI OUT channel	Midi Out	01 — 16	01

### NOTE:

- If you do not press any button for 5 seconds after entering FUNCTION menu, it will quit this menu automatically.

## Transpose

In TRANSPOSE menu, the value of transpose appears on the LCD.

You can press [+]/[-] button or dial to adjust the value from -12 to 12 semitones.

Press [+] and [-] together to set the transpose value to 0.

The transpose value is valid to chord recognize.

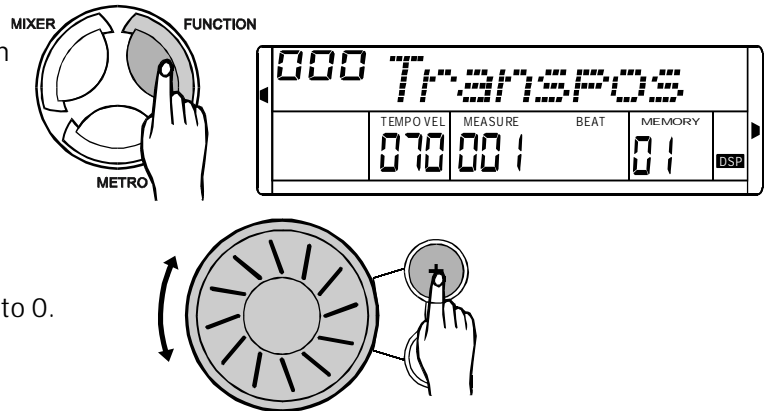

## Tune

In TUNE menu, press [+]/[-] button or dial to adjust tune value from -50 to +50 cents.

Press [+] and [-] together to reset its default value.

The tune value is valid to chord recognize.

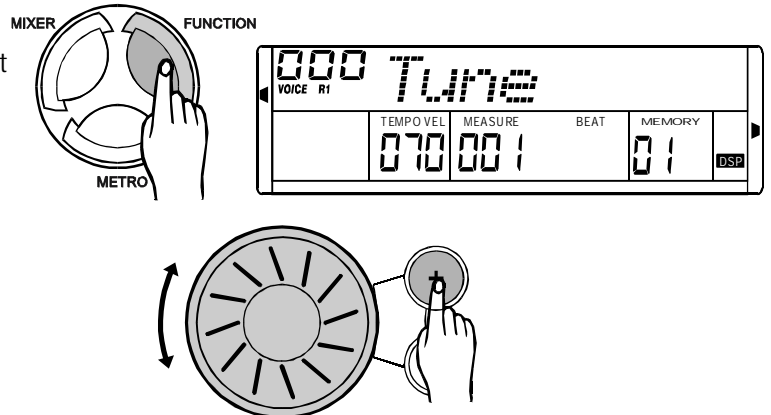

## Beat

The beat type includes 0,2~9 at all.

Press [+]/[-] button or dial to select the beat type.



## Touch

In TOUCH menu, you can adjust TOUCH response level with [+]/[-] button or dial.

The piano has 4 touch response level from OFF to 3.

If you select 'OFF', the TOUCH sign will be erased.

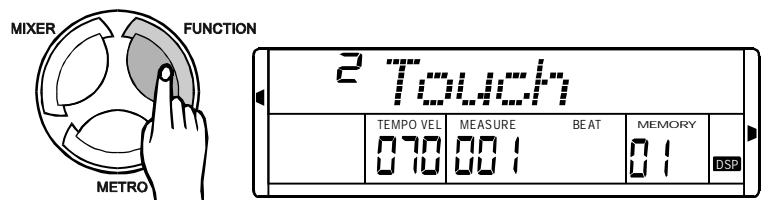

## Split Point

In split point menu, press [+] and [-] button or dial or press the key to set its value.

Parameter Range: from 1 to 88, the default value is 34.

The keys on the right side to the point that you set is right hand area, and the other side is left hand area (chord area).

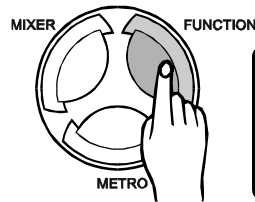

034 Split Pt				
F#	TEMPO VEL	MEASURE	BEAT	MEMORY
	070	001		01
DSP				

## DSP Level

In DSP level menu, press [+] and [-] button or dial or press the key to set its value.

Parameter Range: from off to 7, the default value is 2.

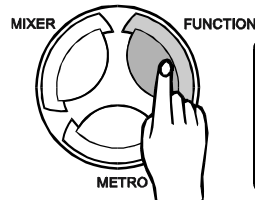

002 DSP Level				
	TEMPO VEL	MEASURE	BEAT	MEMORY
	070	001		01
DSP				

## MIDI IN Channel

In MIDI IN channel menu, press [+] and [-] button or dial or press the key to set its value.

Parameter Range: from 1 to 16, all.

The default receiving channel is all.

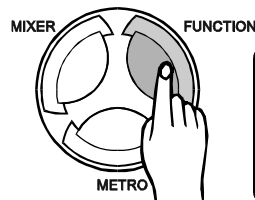

ALL Midi In				
	TEMPO VEL	MEASURE	BEAT	MEMORY
	070	001		01
DSP				

## MIDI OUT Channel

In MIDI OUT channel menu, press [+] and [-] button or dial or press the key to set its value.

Parameter Range: from 1 to 16.

The default transmitting channel is 01.

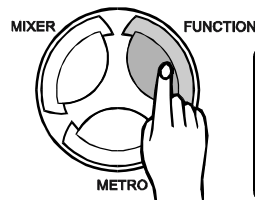

001 Midi Out				
	TEMPO VEL	MEASURE	BEAT	MEMORY
	070	001		01
DSP				

# MIXER

Press [MIXER] button to enter the menu of MIXER.  
The default option of the menu is Drum volume. When you enter this menu next time, you will find the option is the same as last time.

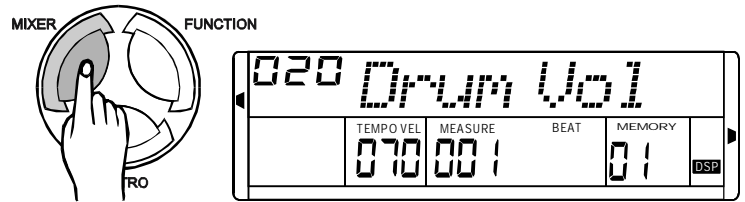

Press [MIXER] button to select the option you want to set.  
You can adjust keyboard voice volume, style volume through MIXER by pressing [+] and [-] button or using dial.

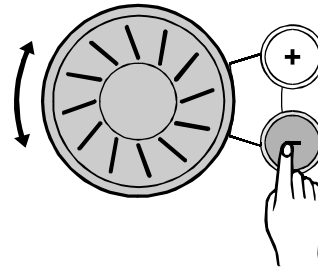

The option and the parameters are as the follow:

Adjust content	LCD Display	Range	Default value
DRUM volume	Drum Vol	000 - 031	020
BASS volume	Bass Vol	000 - 031	018
ORCHESTRA volume	Orc Vol	000 - 031	021
UPPER1 volume	Voice R1	000 - 031	024
UPPER2 volume	Voice R2	000 - 031	012
LOWER volume	Voice L	000 - 031	012

## NOTE:

- If you do not press any button for 5 seconds after entering MIXER menu, it will quit this menu automatically.
- When you press [+] and [-] together, the volume you are setting will turn off.

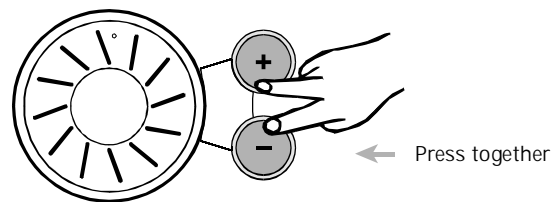

# Memory

Memory can be used to memorize 16 complete control—panel setups (4 banks with 4 presets each) that you can recall whenever needed.

## Memory Bank

1. There are 4 banks in total, each bank has 4 memories (M1—M4).
2. Press [BANK] to select bank 1—bank4 in turn, the LCD displays MEMORY 0X.
3. Press [M1]~[M4], the MEMORY 0X—X will appear on the LCD.

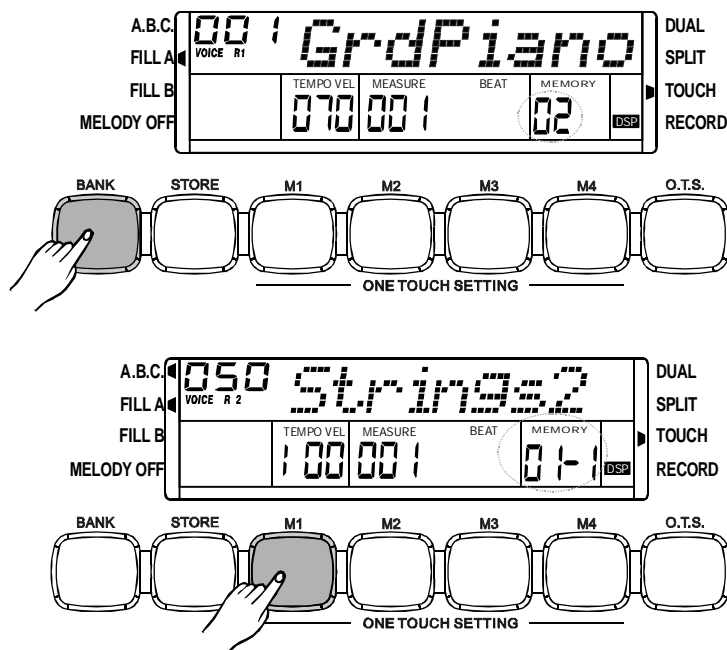

## Store/Load Parameter

1. Press and hold [STORE] button, then press [M1] (or [M2]—[M4]) meanwhile, the data will be stored to M1 (or M2—M4). Please note that it will clear the recorded data.
2. Press M1 (or M2—M4) to load the data from memory, the memory number will appear on LCD.
3. If you power off the piano, the memory data will not be erased.

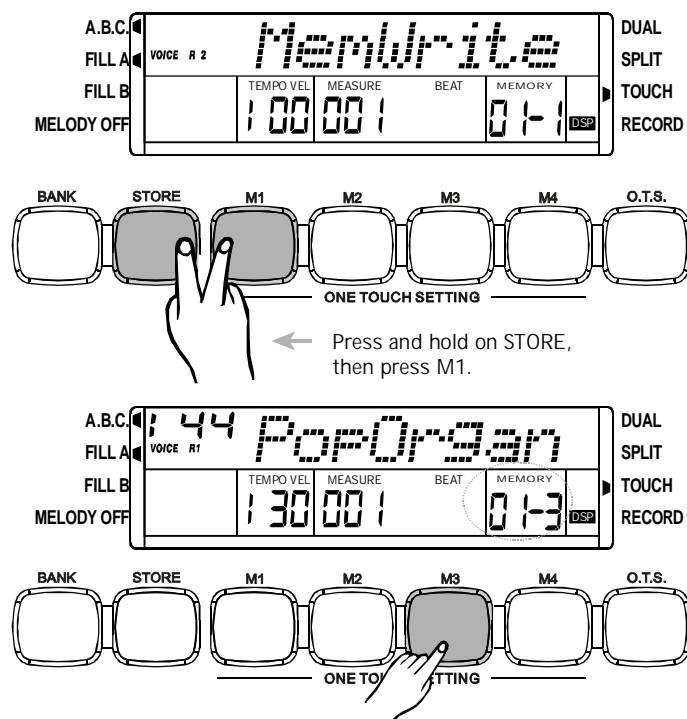

## Memory Data

The memory saving data includes: main voice, dual voice, left—hand voice, styles, tempo, function, mixer, accomp volume, ABC mode, normal/variation mode etc.

### NOTE:

- Once the memory data be modified, the memory number displayed on LCD will disappear.

## Clear Memory Data

1、 Press [STORE] and [M1] together, then turn on the piano, the default data will be loaded to the piano.

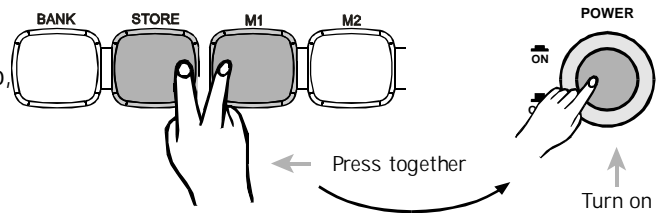

2、 Press [+] and [-] together, then turn on the piano, the default data will be loaded to the piano, and the record song will be lost.

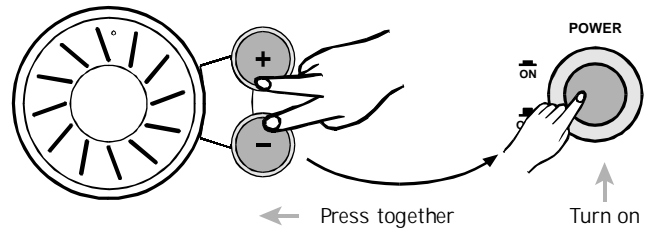

## One Touch Setting

One Touch Setting is a powerful and convenient function that allows you to reconfigure all settings instantly with the touch of a single button. In this function, 4 types of parameters (M1 ~M4) will be loaded for operating the current style.

The parameters stored in the O.T.S. Including:  
 VOICE R1、 VOICE R1 VOLUME、 VOICE R1 OCT  
 VOICE R2、 VOICE R2 VOLUME、 VOICE R2 OCT

1、 Select one of the styles.

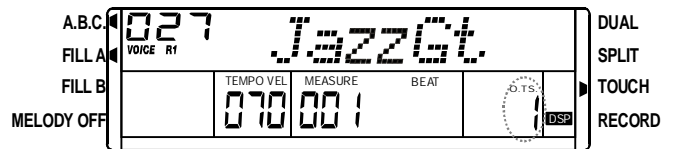

2、 Each style has four presets.

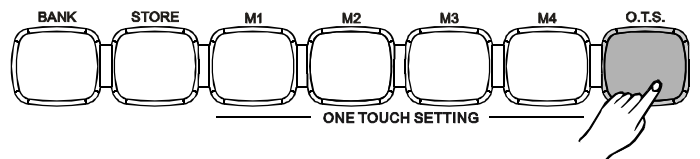

3、 Press the [O.T.S.] button to turn this mode on and the O.T.S. Flag lightens on the LCD. A.B.C. mode would be turned on automatically.

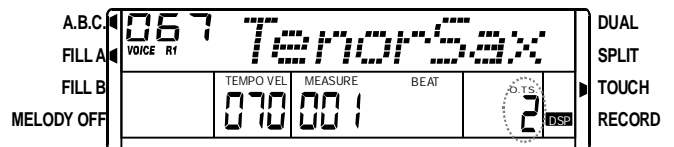

4、 Press any of the [ M1] ~[M4] buttons which is corresponded to your desired setting. LCD displays O.T.S. 1-4.

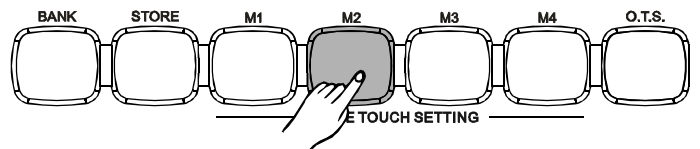

5、 Press [O.T.S.] button again to exit the O.T.S. mode, LCD displays MEMORY.

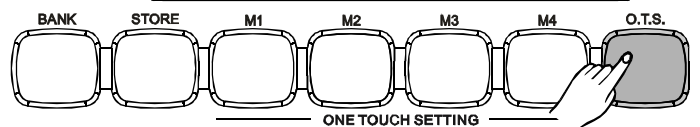
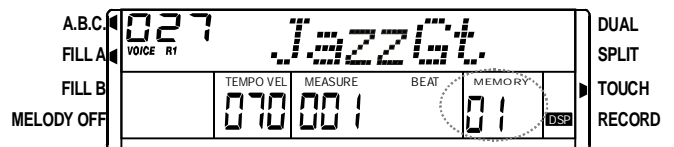

**NOTE:**

- While you are recording or playing back a recorded song, press any of the [M1] ~[M4] button, no "FILL IN" will be inserted.

# Record

## Record Waiting

1. Press [RECORD] to enter record waiting mode, the REC flag lit up on LCD, the beat starts flashing.
2. Then you can select voice number, style number and adjust tempo, mixer parameters.

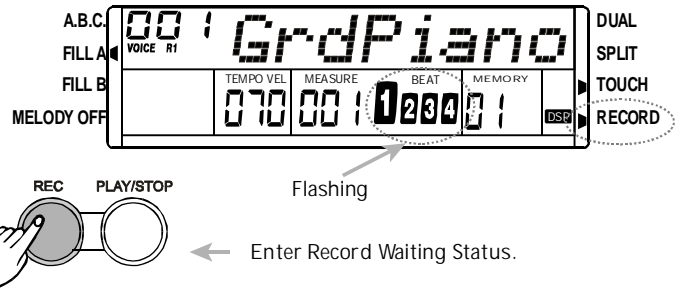

## Start Record

1. In the record waiting mode, press [START/STOP] or press any key on the keyboard to start recording.
2. And the beat will display according to the current tempo.

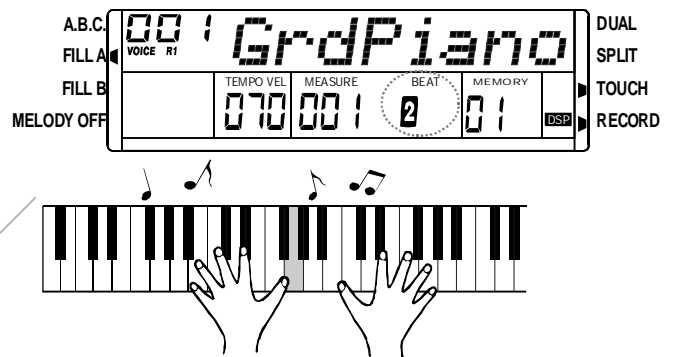
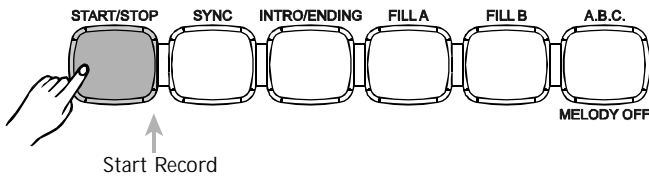

### NOTE:

- If you power off the piano, the recorded data will not be erased.
- Press[+] and [-] together, then turn on the piano, the default data will be loaded to the piano, and the recorded data will be lost.
- Press [RECORD] and [PLAY/STOP] together, then turn on the piano, the recorded data will be lost.

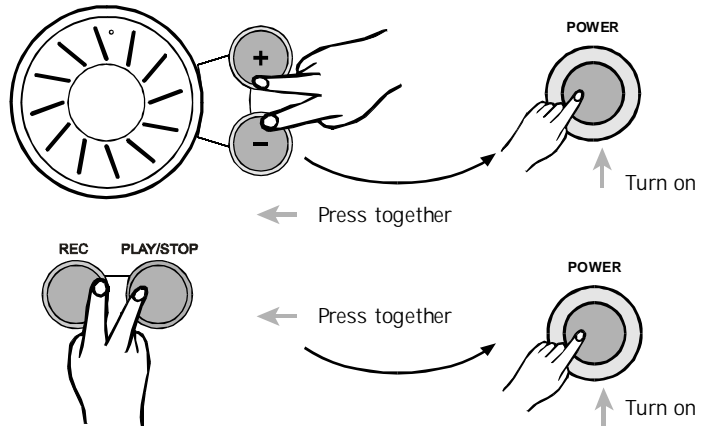

## Stop Record

1. In the recording mode, press [RECORD] to stop recording.
2. If the memory is full, the recording will be stopped automatically, "FULL" will appear on LCD.

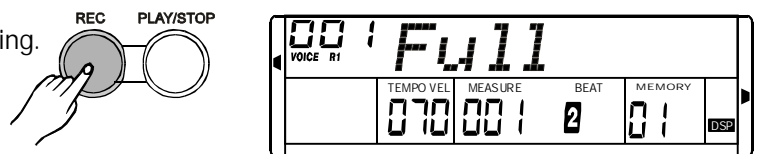

## Playback Record

1. Press [PLAY/STOP] button to start playing the recorded data.
2. Press [PLAY/STOP] button again to stop playing.

### NOTE:

- If the recording memory is empty, when you press [PLAY/STOP], "EMPTY" will appear temporarily on LCD.

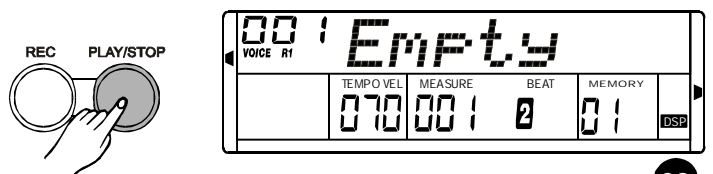

# Song

The piano has 60 songs with MELODY OFF function, which allows you to listen to the Song playback without the melody, useful for you to play with the song.

1. Press [SONG] to enter song mode, the flag of song lit up on the LCD.

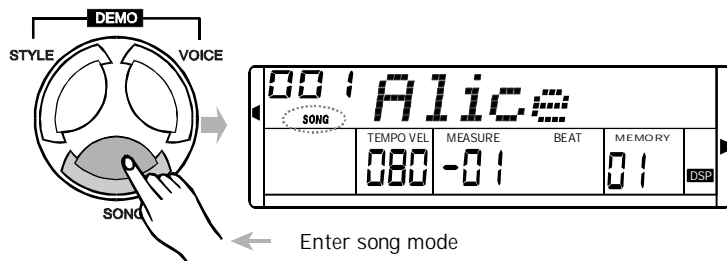

2. Press [START/STOP] to play song, press [START/STOP] again to stop song playing.

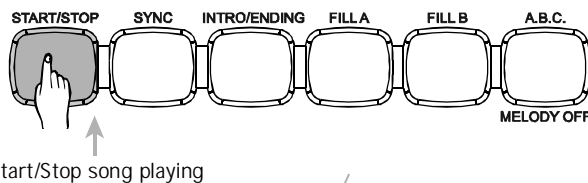

3. When you stop the song play, press [STYLE], [VOICE], [DUAL] or [LOWER] to exit song mode.

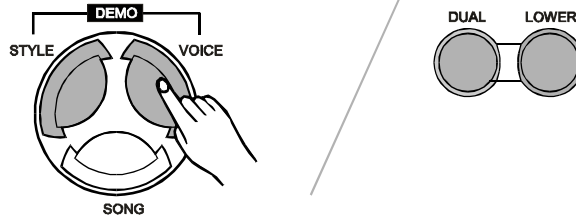

4. Press [+] /[-] or dial to select song number, the name of song will appear on the LCD.

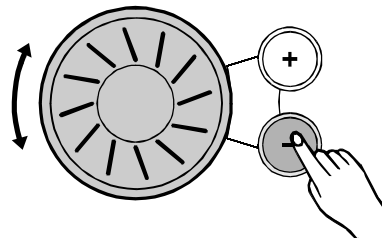

5. The song starts to play with its own introductory beat which measure is from negative value to 001.

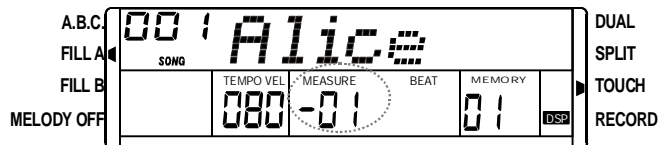

6. When in SONG mode, press [MELODY OFF] could turn on/off the main melody of the song.

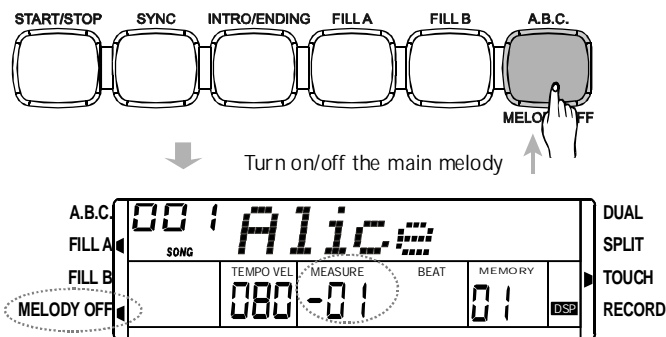

## NOTE:

- When start playing the song with [SONG], it will play all of the songs in circle.
- If you play the song by pressing [START/STOP], it will play the current song repeatedly.

# Specifications

1 Keyboard.....	88 Keys, 3 kinds of touch level.
2 Voices.....	210 Voices.
3 Styles.....	120 Voices.
4 Demo/Song.....	3 Demos, 60 Songs.
5 Polyphony.....	64-note (turn off DSP effect)、38-note (turn on DSP effect) .
6 Display.....	Multi-functional LCD display with blue backlit.
7 Switch and Buttons.....	POWER SWITCH、VOLUME、AUTO BASS CHORD、MELODY OFF、 ACCOMP VOLUME +/-、TEMPO +/-、FUNCTION、MIXER、 METRONOME、DEMO、SONG、VOICE、STYLE、 +/-、BANK、 STORE (M1-M4)、ONE TOUCH SETTING、DUAL、SPLIT、RECORD、 PLAY/STOP.
8 Accompaniment Control.....	START/STOP、SYNC START、INTRO/ENDING、FILL A、FILL B.
9 Record.....	RECORD、PLAY/STOP.
10 Panel Memory.....	4 Banks, each has 4 memories.
11 MIDI.....	Receive / transmit.
12 Connectors.....	AUX.OUT、HEADPHONES、3 PEDALS、USB、AC POWER.
13 Speaker.....	8ohm 25WX2 .
14 Dimension(L×W×H).....	1419×460×832mm.
15 Weight.....	40KG.
16 Accessories.....	Instruction Manual.

\* All specifications and appearances are subject to change without notice.

# Trouble Shooting

Problem	Possible Cause and Solution
No matter the instrument is turned on or off, a popping sound will be temporarily produced.	This is normal and indicates that the instrument is receiving electrical power.
There is no sound even when the keyboard is played or when a song or style is being played.	Check if any cable or headphone is connected to the PHONES jack on the left underneath the piano body.. When a set of headphones is plugged into this jack, no sound is output.

# Appendix 1- Voice List

NO	NAME
1	Acoustic Grand Piano
2	Bright Acoustic Piano
3	Electric Grand Piano
4	Honky - Tonk Piano
5	Electric Piano 1
6	Electric Piano 2
7	Harpsichord
8	Clavi
9	Celesta
10	Glockenspiel
11	Music Box
12	Vibraphone
13	Marimba
14	Xylophone
15	Tubular Bells
16	Dulcimer
17	Drawbar Organ
18	Jazz Organ
19	Rock Organ
20	Church Organ
21	Reed Organ
22	Accordion
23	Harmonica
24	Tango Accordion
25	Nylon Guitar
26	Steel Guitar
27	Jazz Guitar
28	Clean Guitar
29	Muted Guitar
30	Overdriven Guitar
31	Distortion Guitar
32	Guitar Harmonics
33	Acoustic Bass
34	Finger Bass
35	Pick Bass
36	Fretless Bass
37	Slap Bass 1
38	Slap Bass 2
39	Synth Bass 1
40	Synth Bass 2

NO	NAME
41	Violin
42	Viola
43	Cello
44	Contrabass
45	Tremolo Strings
46	Pizzicato Strings
47	Orchestral Harp
48	Timpani
49	StringsEnsemble1
50	StringsEnsemble
51	Synth Strings1
52	Synth Strings 2
53	Choir Aahs
54	Voice Oohs
55	SynthVoice
56	Orchestra Hit
57	Trumpet
58	Trombone
59	Tuba
60	Muted Trumpet
61	French Horn
62	Brass Section
63	Synth Brass 1
64	Synth Brass 2
65	Soprano Sax
66	Alto Sax
67	Tenor Sax
68	Baritone Sax
69	Oboe
70	English Horn
71	Bassoon
72	Clarinet
73	Piccolo
74	Flute
75	Recorder
76	Pan Flute
77	Blown Bottle
78	Shakuhachi
79	Whistle
80	Ocarina

NO	NAME
81	Square
82	Sawtooth
83	Calliope
84	Chiff
85	Charang
86	Voice
87	Fifths
88	Bass Lead
89	Fantasia
90	Warm
91	Poly Synth
92	Choir
93	Bowed
94	Metallic
95	Halo
96	Sweep
97	Fx1(rain)
98	Fx2(soundtrack)
99	Fx3(crystal)
100	Fx4(atmosphere)
101	Fx5(brightness)
102	Fx6(goblins)
103	Fx7(echoes)
104	Fx8(sci - fi)
105	Sitar
106	Banjo
107	Shamisen
108	Koto
109	Kalimba
110	Bag Pipe
111	Fiddle
112	Shanai
113	Tinkle Bell
114	Agogo
115	Steel Drums
116	Wood Block
117	Taiko Drum
118	Melodic Tom
119	Synth Drum
120	Reverse Cymbal
121	Guitar Fret Noise
122	Breath Noise

## Appendix 1- Voice List

NO	NAME
123	Seashore
124	Bird Tweet
125	Telephone Ring
126	Helicopter
127	Applause
128	Gunshot
Keyboard	
129	Pianostr
130	Modern Electric Piano
131	Solo Piano
132	Polar
133	Grand Harpsi
134	Clavi 2
135	Bell
136	Bell 2
137	Vibes 2
138	Vibesma
139	Marimba2
Organ	
140	Electric Organ
141	Jazz Organ 2
142	Jazz Organ 3
143	Clik Organ
144	Pop Organ
145	Church Organ 2
146	ElectricOrgan 2
147	Tremob Organ
148	Q-Organ
Accordion	
149	Accordion2
150	Soft Accordion
151	Soft Accordion 2
152	Harmonic
gt&bass	
153	N-Gthamm
154	12StrGuitar
155	Clean Guitar 2

NO	NAME
156	Solidwa
157	Overdriven Guitar 2
158	Tremolo Guitar
159	Funk Guitar
160	Bass Cymbal
161	Synth Bass 3
162	Synth Bass 4
strings	
163	Viola 2
164	Cello 2
165	Cello 3
166	Strings Ensemble 3
167	Strings Ensemble 4
168	Synth Strings 3
169	Dream Strings
brass&pipe	
170	Trombone2
171	FM Horn
172	Bbbrass
173	Hibrass
174	Tenosax 2
175	Basso 2
lead	
176	Whistle 2
177	Pan Flute 2
178	Lead1
179	Lead3
180	Warplead
pad	
181	Sinepad
182	Softpad

NO	NAME
183	Bellpad
184	Synpad
185	Hornpad
186	Newagpad
187	Bagpipe
chinese instrument	
188	PI PA
189	YUE QIN
190	MID RUAN
191	GU ZHEN
192	YANG QIN
193	ER HU
194	GAO HU
195	SUO NA
196	LU SHEN
197	QU DI
198	BANG DI
199	XIAO
DRUM KIT	
200	Standard Drum 1
201	Standard Drum 2
202	Room Drum
203	Rock Drum
204	Electric Drum
205	Analog Drumset
206	Dance Drumset
207	Jazz Drum
208	Brush Drumset
209	Standard Drumset
210	Chinese Percussion

# Appendix 2-Style List

NO	NAME
8 BEAT & 16 BEAT	
001	8 Beat
002	Guitar Pop 1
003	8 Beat Disco
004	8 Beat Dance
005	60's 8 Beat
006	Pop Funk
007	16 Beat Ballad
008	Pop 16 Beat 1
009	Pop 16 Beat 2
010	16 Beat Modern
011	Modern 16 Beat
012	16 Beat Bossa Nova
013	16 Beat Funk
014	Cool Beat
POP	
015	Guitar Pop 2
016	Pop beat
017	Soft Beat
018	Sting Latin
019	Brit Pop 1
020	BritPop 2
021	New Age
022	Pop Hit
023	Fusion Shuffle
BALLAD	
024	Folk Ballad
025	Pop Ballad 1
026	Pop Ballad 2
027	Rock Ballad
028	Easy Ballad
029	Love Ballad
030	Natural Ballad
031	Piano Ballad
032	EP Ballad
033	New R&B Ballad
ROCK	
034	Rock
035	Folk Rock
036	Slow Rock1
037	Hard Rock

NO	NAME
038	6/8 Rock
039	Rock & Roll
040	70's Rock & Roll
041	Rock Shuffle
042	4/4 Blues
DANCE	
043	Club Dance
044	Disco
045	70's Disco Funk
046	Garage
047	Rap 1
048	Rap 2
049	House
050	Euro Dance
051	Techno
SOUL & FUNK	
052	Jazz Funk
053	Cool Funky
054	Groove
055	Samba Funk
056	Soul
057	Soul Beat
058	Hip Hop Soul
059	British Soul Pop
060	Hip Hop Beat
061	R & B Ballad
JAZZ	
062	Swing
063	Jazz Brush
064	Cool Jazz Ballad
065	Acid Jazz 1
066	Acid Jazz 2
067	Big Band Medium
068	Big Band Ballad
069	Swing Shuffle
070	Fusion
071	Jazz Fusion
COUNTRY	
072	Country 8 Beat
073	Country Pop 1
074	Country Ballad
075	Modern Country

NO	NAME
076	Country Folk
077	2/4 Country
078	Country Pop 2
079	Country Shuffle
080	Country Quick Steps
081	Bluegrass
LATIN/BALLROOM	
082	Bossa Nova 1
083	Rhumba
084	Cha Cha Cha
085	Pop Cha Cha
086	Beguine
087	Tango
088	Swing Fox
089	Mambo
090	Salsa
091	Samba
092	Pasodoble
093	Slow Bolero
094	Habanera
095	Latin Rock
TRADITIONAL	
096	March
097	German March
098	6/8 March
099	Polka
100	Polka Pop 1
101	Polka Pop 2
102	Slow Waltz
103	Country Waltz
104	Jazz Waltz
105	Musette
PIANO	
106	Pianist
107	Ballad
108	Slow Rock 2
109	Bossa Nova2
110	Twist
INDONESIA	
111	Dandut 1
112	Dandut 2
113	Dangdu
114	Dangdut 1
115	Dangdut 2
116	Dangdut 3
117	Kercong 1
118	Kercong 2
119	PopKcong
120	Sdangdut

## Appendix 3-Song List

NO	NAME
<b>PIANO</b>	
1	For Alice
2	Habanera
3	Four Little Swans
4	Moseta Dance
5	Germanic Dance
6	Turkish March
7	March
8	Away In A Manger
9	Chopsticks
10	2-Part Invention # 13 In A Minor.B.W. lli
<b>FOLK &amp; COUNTRY</b>	
11	Country
12	Jambalaya
13	Susanna
14	Bridge
15	Battle Hymne Of The Republic
16	The Old Gray Mare
17	American Patrol
18	In The Rain
19	Sippin`Cider Through A Straw
<b>GOLDEN &amp; POP</b>	
20	Are You Lonesome Tonight
21	Only You
22	End Of The World
23	House Of Rising Sun
24	The Blue-Bells Of Scotland
25	Over The Rainbow
26	Beautiful Dreamer
27	Edelweiss
28	O Sole Mio
29	Silent Night
30	Ave Maria
31	Five Hundred Miles

NO	NAME
32	Happy New Year
33	It`S Beginning To Look A Lot Like Christmas
34	Jeanie With The Light Brown Hair
35	My Bonnie
36	Song Of The Pearlfisher
37	The Stage Coach
38	Entertainer
39	Annie Laurie
40	Killing Me Softly With His Song
41	Last Rose Of Summer
42	The Old King Cole
<b>JAZZ &amp; FUSION</b>	
43	Maple Leaf Rag
44	June Samba
45	Funk
46	I Can.....
47	Sea Shore
48	Guitar&Saxphone
49	The Hip Hop`S Night
50	Blue Lunch
51	Cobweb
52	Wine
53	Jazz Old Man
54	Dark Eyes
55	Carlos
56	Sad
57	The Jazz
<b>CHINESE</b>	
58	South Mud Bay
59	Give You A Rose
60	Flowing Rill

## Appendix 3-Song List

NO	NAME
1	DEMO1
2	DEMO2
3	DEMO3

# Appendix 5-Chord List

	Chord Name[Abbreviation]	Normal Voicing	Chord	Display
0	Major[M]	1-3-5	C	C
1	Major sixth[6]	1-(3)-5-6	C6	C6
2	Major seventh[M7]	1-3-(5)-7	CM7	CM7
3	Major seventh sharp Eleventh[M7#11]	1-(2)-3-#4-(5)-7	CM7#11	CM7(#11)
4	Major add ninth[Madd9]	1-2-3-5	<b>C Madd9</b>	CM(9)
5	Major ninth[M9]	1-2-3-(5)-7	CM9	CM7(9)
6	Major sixth add ninth[6 9]	1-2-3-(5)-6	C6 9	C6(9)
7	augmented[aug]	1-3-#5	Caug	Caug
8	Minor[m]	1-b3-5	Cm	Cm
9	Minor sixth[m6]	1-b3-5-6	Cm6	Cm6
10	Minor Seventh[m7]	1-b3-(5)-b7	Cm7	Cm7
11	Minor seventh flatted fifth[m7b5]	1-b3-b5-b7	Cm7b5	Cm7(b5)
12	Minor add ninth[madd9]	1-2-b3-5	Cmadd9	Cm(9)
13	Minor ninth[m9]	1-2-b3-(5)-b7	Cm9	Cm7(9)
14	Minor eleventh[m11]	1-(2)-b3-4-5-(b7)	Cm11	Cm7(11)
15	Minor major ninth[mM7]	1-b3-(5)-7	CmM7	CmM7
16	Minor major ninth[mM9]	1-2-b3-(5)-7	CmM9	CmM7(9)
17	Diminished[dim]	1-b3-b5	Cdim	Cdim
18	Diminished seventh[dim7]	1-b3-b5-6	Cdim7	Cdim7
19	Seventh[7]	1-3-(5)-b7	C7	C7
20	Seventh suspended Fourth[7sus4]	1-4-5-b7	C7sus4	C7sus4
21	Seventh flatted Fifth[7b5]	1-3-b5-b7	C7b5	C7(b5)
22	Seventh Ninth[79]	1-2-3-(5)-b7	C7 9	C7(9)
23	Seventh sharp eleventh[7#11]	1-2-3-#4-(5)-b7or 1-(2)-3-#4-5-b7	C7#11	C7(#11)
24	Seventh thirteenth[7 13]	1-3-(5)-6-b7or 2-3-5-6-b7	C7 13	C7(13)
25	Seventh flatted Ninth[7b9]	1-b2-3-(5)-b7	C7b9	C7(b9)
26	Seventh flatted Thirteenth[7b13]	1-3-5-b6-b7	C7b13	C7(b13)
27	Seventh Sharp ninth[7#9]	(1)-#2-3-(5)-b7	C7#9	C7(#9)
28	Major Seventh augmented[M7aug]	1-3-#5-7	CM7aug	CM7aug
29	Seventh augmented[7aug]	(1)-3-#5-b7	C7aug	C7aug
30	Suspended Fourth[sus4]	1-4-5	Csus4	Csus4
31	One plus two plus five[1+2+5]	1-2-5	C1+2+5	C

# Appendix 6-MIDI Implementation Chart

Function		Transmitted	Recognized	Remarks
Basic Channel	Default Changed	1ch 1-16ch	1-16ch 1-16ch	
Mode	Default Messages Altered	× × *****	3 × ×	
Note Number :	True voice	9-120 *****	0-127 0-127	
Velocity:	Note on Note off	○ 9nH,V=1-127 ×	○ 9nH,V=1-127 ×	
After Touch	Keys Chs	× ×	× ×	
PitchBend		○	○	
Control Change	0 1 5 6 7 10 11 64 65 66 67 80 81 91 93 120 121 123	○ ○ × ○ ○ × × ○ × × ○ ○ ○ ○ ○ × × ○	○ ○ ○ ○ ○ ○ ○ ○ ○ ○ ○ ○ ○ ○ ○ ○ ○ ○	Bank Select Modulation Portamento Time Data Entry Volume Pan Expression Sustain Pedal Portamento ON/OFF Sostenuto Pedal Soft Pedal Reverb Program Chorus Program Reverb Level Chorus Level All Sound Off Reset All Controllers All Notes Off
Program Change	: True #	○ *****	○ 0-127	
System Exclusive		×	○	
System	: Song Position : Song Select : Tune	× × ×	× × ×	
System Real Time	: Clock : Commands	× ×	× ×	
Aux Messages	: Local on/off : All Notes off : Active sense : Reset	× ○ × ×	× ○ ○ ○	
Note:	*1 When the accompaniment is started, an FAH message is transmitted. When accompaniment is stopped, an FCH message is transmitted. When an FAH message is received, accompaniment is started. When an FCH message is received, accompaniment is stopped.			

Mode 1: OMNI ON , POLY      Mode 2 : OMNI ON , MONO      ○ : YES  
 Mode 3: OMNI OFF , POLY    Mode 4 : OMNI OFF , MONO    × : NO