



User's Guide

C710n
C710dn
C710dtn
C710cdtn



PREFACE

Every effort has been made to ensure that the information in this document is complete, accurate, and up-to-date. The manufacturer assumes no responsibility for the results of errors beyond its control. The manufacturer also cannot guarantee that changes in software and equipment made by other manufacturers and referred to in this guide will not affect the applicability of the information in it. Mention of software products manufactured by other companies does not necessarily constitute endorsement by the manufacturer.

While all reasonable efforts have been made to make this document as accurate and helpful as possible, we make no warranty of any kind, expressed or implied, as to the accuracy or completeness of the information contained herein.

The most up-to-date drivers and manuals are available from:

<http://www.okiprintingsolutions.com>

Copyright © 2009. All rights reserved.

Oki is a registered trademark of Oki Electric Industry Company, Ltd.

Oki Printing Solutions is a registered trademark of Oki Data Corporation.

Energy Star is a trademark of the United States Environmental Protection Agency.

Microsoft, MS-DOS and Windows are registered trademarks of Microsoft Corporation.

Apple, Macintosh, Mac and Mac OS are registered trademarks of Apple Computer.

Other product names and brand names are registered trademarks or trademarks of their proprietors.



As an Energy Star Program Participant, the manufacturer has determined that this product meets the Energy Star guidelines for energy efficiency.



This product complies with the requirements of the Council Directives 2004/108/EC (EMC) and 2006/95/EC (LVD) and 1999/5/EC (R&TTE), as amended where applicable on the approximation of the laws of the member states relating to electromagnetic compatibility, low voltage and radio & telecommunications terminal equipment.

Please note that Microsoft Windows XP was used to produce all screenshots in this manual. These screenshots may vary if you are using any other operating system, but the principle is the same.

EMERGENCY FIRST AID

Take care with toner powder:

If swallowed, give small amounts of cold water and seek medical attention. DO NOT attempt to induce vomiting.



If inhaled, move the person to an open area for fresh air. Seek medical attention.

If it gets into the eyes, flush with large amounts of water for at least 15 minutes keeping eyelids open. Seek medical attention.

Spillages should be treated with cold water and soap to help reduce risk of staining skin or clothing.

MANUFACTURER

Oki Data Corporation,
4-11-22 Shibaura, Minato-ku,
Tokyo 108-8551, Japan

IMPORTER TO THE EU/AUTHORISED REPRESENTATIVE

Oki Europe Limited (trading as OKI Printing Solutions)

Blays House
Wick Road
Egham
Surrey, TW20 0HJ
United Kingdom

For all sales, support and general enquiries contact your local distributor

ENVIRONMENTAL INFORMATION



CONTENTS

Preface	2
Emergency First Aid	3
Manufacturer	3
Importer to the EU/Authorised Representative	3
Environmental information	3
Contents	4
Notes, Cautions and Warnings	5
Introduction	6
Printer overview	7
Front view	7
Rear view	8
Changing the display language	8
Paper recommendations	9
Cassette trays	9
Multi purpose tray	10
Face down stacker	10
Face up stacker	10
Duplex unit	10
Loading paper	11
Cassette trays	11
Multi purpose tray	14
Operation	15
Using the machine	15
Menu functions	16
Operator Panel:	16
How to change the settings - User	17
How to change the settings - Administrator	17
Configuration Menu	18
Print information menu	19
Print secure Job	20
Menus	21
Shutdown menu	24
Admin Setup	25
Calibration	35
Print Statistics	35
Administrator (Boot) Menu	37
Replacing consumable items	40
Toner:	40
Image drum:	40
Transfer belt:	40
Fuser:	40
Consumable order details	40
Toner cartridge replacement	41
Image drum replacement	45
Replacing the Transfer belt unit	48
Fuser replacement	50
Cleaning the LED head	51
Installing upgrades	52
Duplex unit	53
Memory upgrade	54
Hard disk drive	57
Additional paper tray(s)	59
Adjusting Windows printer drivers	60

Storage Cabinet60
Clearing paper jams61
Major Printer components and paper path61
Paper sensor error codes62
Specifications68
Index70
Oki contact details71

NOTES, CAUTIONS AND WARNINGS

NOTE:

A note provides additional information to supplement the main text.

CAUTION!

A caution provides additional information which, if ignored, may result in equipment malfunction or damage.

WARNING!

A warning provides additional information which, if ignored, may result in a risk of personal injury.

For the protection of your product, and in order to ensure that you benefit from its full functionality, this model has been designed to operate only with genuine original toner cartridges. Any other toner cartridge may not operate at all, even if it is described as "compatible", and if it does work, your product's performance and print quality may be degraded.

Use of non-genuine products may invalidate your warranty.

Specifications subject to change without notice. All trademarks acknowledged.

INTRODUCTION

Congratulations on buying this Oki Printing Solutions colour printer. Your new printer is designed with advanced features to give you clear, vibrant colour prints and crisp black and white pages at high speed on a range of print media for the office.

Your printer includes these features:

- > ProQ2400, multi-level technology produces subtler tones and smoother gradations of colour to lend photographic quality to your documents;
- > Up to 30 pages per minute in full colour for fast printing of high impact colour presentations and other documents;
- > Up to 32 pages per minute in black and white for fast and efficient printing of all general purpose documents not requiring colour;
- > 600 x 600, 1200 x 600 dpi (dots per inch) and ProQ2400 print resolution for high quality image production showing the finest detail;
- > Internet Protocol version 6 (IPv6)
- > Single Pass colour Digital LED technology for high speed processing of your printed pages;
- > Profile Assistant utility allows you to download ICC profiles to the hard disc (Hard Disc Drive required);
- > PostScript 3, PCL 5C, PCL 6 and Epson FX emulations for industry standard operation and wide compatibility with most computer software;
- > 10Base-T and 100Base-TX network connection lets you share this valuable resource among users on your office network;
- > Photo Enhance mode to improve printouts of photographic images (Windows PCL driver only);
- > "Ask Oki" – a user-friendly function for Windows that provides a direct link from your printer driver screen to a dedicated web site specific to the exact model you are using. This is where you'll find all the advice, assistance and support you could need to help you get the best possible results from your Oki printer;
- > "WebPrint Internet Explorer plugin" - another function for Windows that enables you to print web pages properly;
- > Template Manager utility for Windows enables the design and print of Business cards, banners, labels with ease.
- > 530 A4 sheet main paper tray capacity.

Additionally, the following optional features are also available:

- > Automatic two-sided (duplex) printing for economical use of paper and compact printing of larger documents (standard on dn models);
- > Additional paper tray for loading a further 530 sheets to minimise operator intervention, or different paper stocks for letterhead stationery, alternative paper sizes or other print media;
- > Additional memory allows printing of more complex pages. For example, high resolution banner printing;
- > Internal hard disk drive for storage of overlays, macros and downloadable fonts, and automatic collation of multiple copies of multipage documents and the download of ICC Profiles;
- > Storage Cabinet

PRINTER OVERVIEW

FRONT VIEW

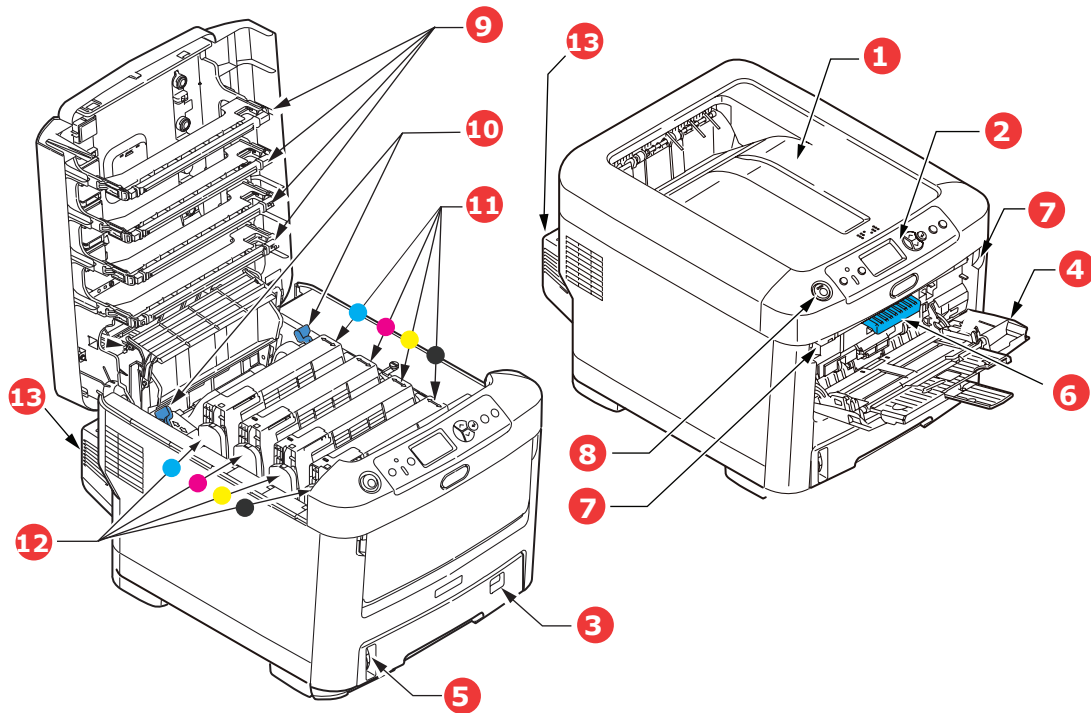

1. Output stacker, face down.

Standard printed copy delivery point. Holds up to 350 sheets at 80g/m².

2. Operator panel.

Menu driven operator controls and LCD display* panel.

3. Paper tray.

Standard paper tray. Holds up to 530 sheets of 80g/m² paper.

4. Multi purpose tray.

Used for feeding heavier paper stocks, envelopes and other special media. Also for manual feeding of single sheets when required.

5. Paper level indicator.

6. Front cover release lever.

7. Multi-purpose tray release recess.

8. Top cover release button.

9. LED heads.

10. Fuser release levers.

11. Toner cartridges (C,M,Y,K).

12. ID units (C,M,Y,K).

13. Duplex unit (when fitted).

*The LCD display language can be changed to show different languages. (see ["Changing the display language"](#) on page 8).

REAR VIEW

This view shows the connection panel, the rear output stacker and the location of the optional duplex (two-sided printing) unit.

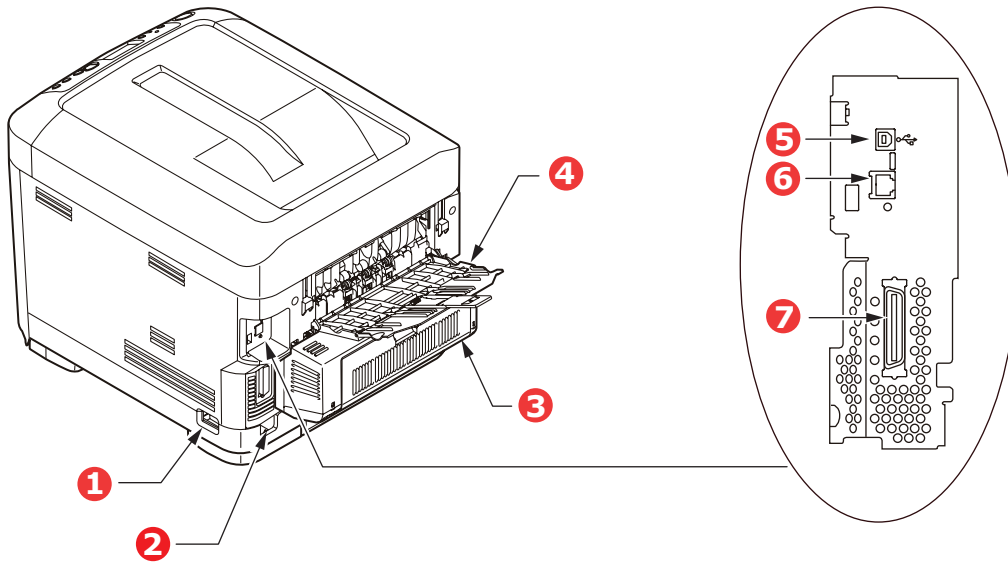

- | | |
|--------------------------------------|-------------------------------|
| 1. ON/OFF switch. | 5. USB interface. |
| 2. AC power socket. | 6. Network interface.* |
| 3. Duplex unit (when fitted). | 7. Parallel interface. |
| 4. Rear, face up stacker. | |

* The Network Interface may have a protective "plug" which must be removed before connection can be made.

When the rear paper stacker is folded down paper exits the printer through the rear of the printer and is stacked here face up. This is mainly used for heavy print media. When used in conjunction with the multi purpose feed tray, the paper path through the printer is essentially straight. This avoids bending the paper around curves in the paper path and enables feeding of up to 220g/m² media.

CHANGING THE DISPLAY LANGUAGE

The default language used by your printer for display messages and for report printing is English. If required, this can be changed to:

German	Danish
French	Dutch
Italian	Turkish
Spanish	Portuguese
Swedish	Polish
Russian	Greek
Finnish	Czech
Hungarian	Norwegian

NOTE:

1. The list above is neither conclusive nor exhaustive.

2. See the information enclosed with the product (*Operator Panel Language Set-up utility*) on the procedure for changing the language setting.

PAPER RECOMMENDATIONS

Your printer will handle a variety of print media, including a range of paper weights and sizes, transparencies and envelopes. This section provides general advice on choice of media, and explains how to use each type.

The best performance will be obtained when using standard 75~90g/m² paper designed for use in copiers and laser printers. A suitable type is Color Copy by Mondi Business paper.

Use of heavily embossed or very rough textured paper is not recommended.

Pre-printed stationery can be used, but the ink must not offset when exposed to the high fuser temperatures used in the printing process.

Envelopes should be free from twist, curl or other deformations. They should also be of the rectangular flap type, with glue that remains intact when subjected to hot roll pressure fusing used in this type of printer. Window envelopes are not suitable.

Transparencies should be of the type designed for use in copiers and laser printers. In particular, avoid office transparencies designed for use by hand with marker pens. These will melt in the fuser and cause damage.

Labels should also be of the type recommended for use in copiers and laser printers, in which the base carrier page is entirely covered by labels. Other types of label stock may damage the printer due to the labels peeling off during the printing process.

CASSETTE TRAYS

SIZE	DIMENSIONS	WEIGHT (G/M ²)	
A6 (MP Tray only)	105 x 148mm	Light	64-74g/m ²
A5	148 x 210mm	Medium Light	75 - 82g/m ²
B5	182 x 257mm	Medium	83 - 104g/m ²
Executive	184.2 x 266.7mm	Heavy	105-120g/m ²
A4	210 x 297mm	Ultra heavy1	121-188g/m ²
Letter	215.9 x 279.4mm	Ultra heavy2	189 -220g/m ² *
Legal 13in.	216 x 330mm	Tray 1:	64 - 188g/m ²
Legal 13.5in.	216 x 343mm	Tray 2/3:	64 - 203g/m ²
Legal 14in.	216 x 356mm	MP Tray:	64 - 220g/m ²

If you have identical paper stock loaded in another tray (2nd or 3rd tray if you have one, or multi purpose tray) you can set the printer to automatically switch to the other tray when the current tray runs out of paper. When printing from Windows applications, this function is enabled in the driver settings. When printing from other systems, this function is enabled in the Print Menu. (See ["Menu functions" on page 16.](#))

MULTI PURPOSE TRAY

The multi purpose tray can handle the same sizes as the cassette trays but in weights up to 220g/m². For very heavy paper stock use the face up (rear) paper stacker. This ensures that the paper path through the printer is almost straight.

The multi purpose tray can feed paper widths from 76mm to 215.9mm and lengths from 127.0mm to 1220mm (banner printing).

The multi purpose tray can feed paper widths as small as 100mm and lengths up to 1200mm (banner printing).

For paper lengths exceeding 356mm (Legal 14in.) use paper stock between 90g/m² and 128g/m² and the face up (rear) paper stacker.

Use the multi purpose tray for printing on envelopes and transparencies. Up to 50 sheets of transparencies or 10 envelopes can be loaded at one time, subject to a maximum stacking depth of 10mm.

Paper or transparencies should be loaded print side up and top edge into the printer. Do not use the duplex (two-sided printing) function.

FACE DOWN STACKER

The face down stacker on the top of the printer can hold up to 350 sheets of 80g/m² standard paper, and can handle paper stocks up to 188g/m². Pages printed in reading order (page 1 first) will be sorted in reading order (last page on top, facing down).

FACE UP STACKER

The face up stacker at the rear of the printer should be opened and the tray extension pulled out when required for use. In this condition paper will exit via this path, regardless of driver settings.

The face up stacker can hold up to 100 sheets of 80g/m² standard paper, and can handle stocks up to 220g/m².

Always use this stacker and the multi purpose feeder for paper stocks heavier than 188g/m².

DUPLEX UNIT

This option provides automatic two-sided printing on the same range of paper sizes as tray 2 (i.e. all cassette sizes except A6), using paper stocks from 64 - 120g/m².

*NOTE:
The duplex unit comes as standard with dn models.*

LOADING PAPER

CASSETTE TRAYS

1. Remove the paper tray from the printer.

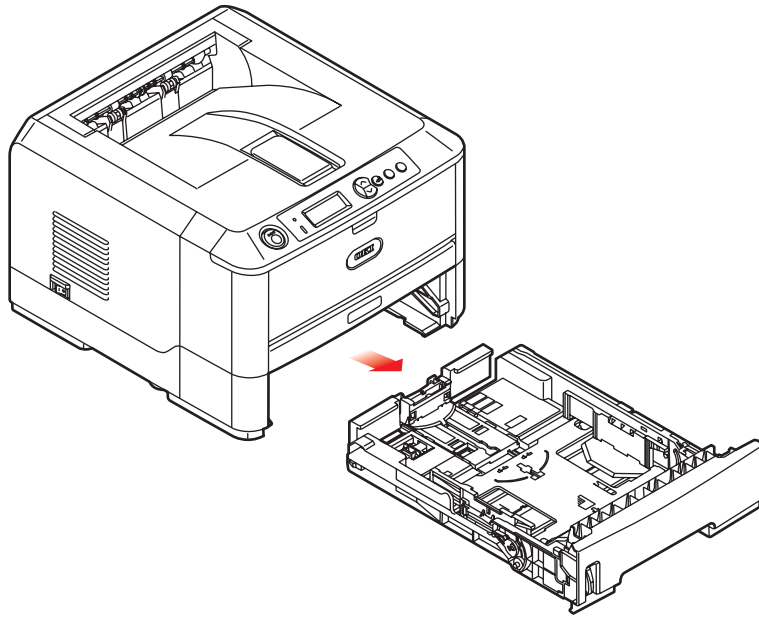

2. Fan the paper to be loaded at the edges (1) and in the middle (2) to ensure that all sheets are properly separated, then tap the edges of the stack on a flat surface to make it flush again (3).

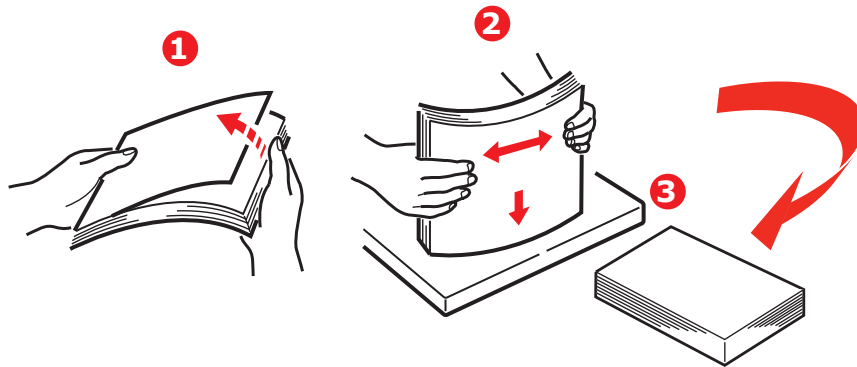

3. Load paper (letter headed paper face down and top edge towards the front of the printer), as shown.

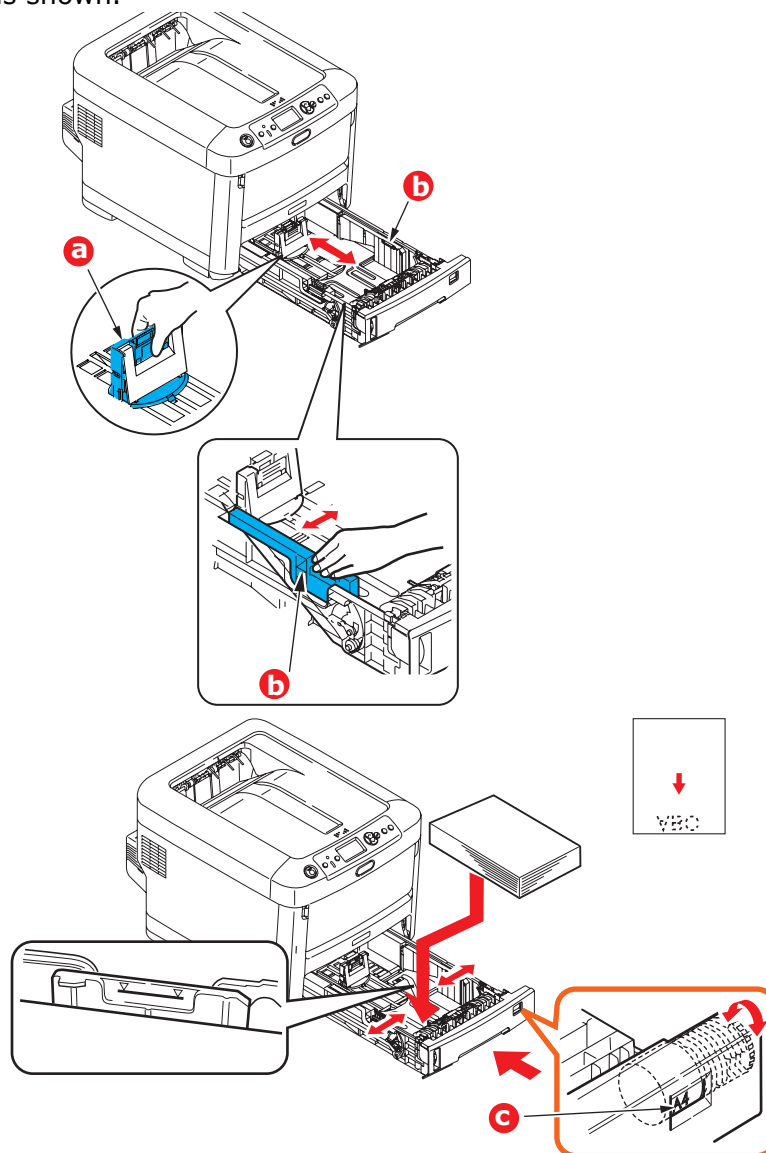

4. Adjust the rear stopper (a) and paper guides (b) to the size of paper being used.
- To prevent paper jams:
- > Do not leave space between the paper and the guides and rear stopper.
 - > Do not overfill the paper tray. Capacity depends on the type of paper stock.
 - > Do not load damaged paper.
 - > Do not load paper of different sizes or types at the same time.
 - > Do not pull the paper tray out during printing (except as described below for the 2nd tray).

CAUTION!

IMPORTANT: Set paper size dial (c) to the size of paper being used (A4 in the above example).

- > Close the paper tray gently.

- > If you have two trays and you are printing from the 1st (upper) tray, you can pull out the 2nd (lower) tray during printing to reload it. However, if you are printing from the 2nd (lower) tray, do not pull out the 1st (upper) tray. This will cause a paper jam.
- > For face down printing, make sure the face up (rear) stacker (a) is closed (the paper exits from the top of the printer). Stacking capacity is approximately 350 sheets, depending on paper weight.
- > For face up printing, make sure the face up (rear) stacker (a) is open and the paper support (b) is extended. Paper is stacked in reverse order and tray capacity is approximately 100 sheets, depending on paper weight.
- > Always use the face up (rear) stacker for heavy paper (card stock etc.).

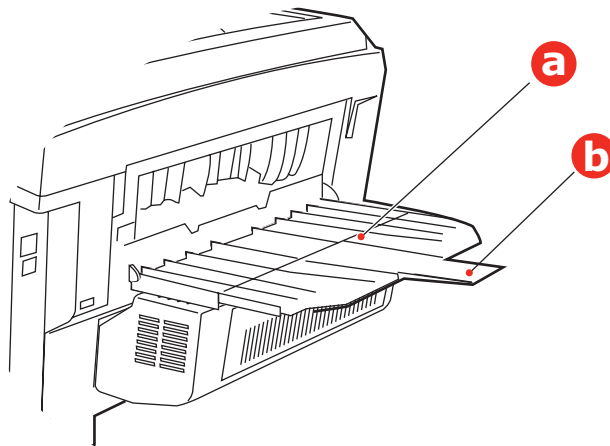

CAUTION!

Do not open or close the rear paper exit while printing as it may result in a paper jam.

MULTI PURPOSE TRAY

1. Open the multi purpose tray (a).
2. Fold out the paper supports (b).

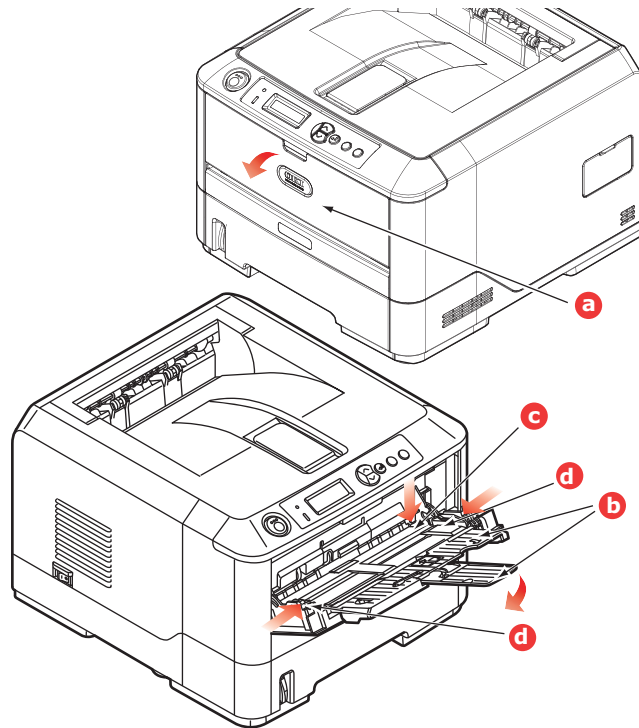

3. Press gently down on the paper platform (c) to ensure it is latched down.
4. Load the paper and adjust the paper guides (d) to the size of paper being used.
 - > For single-sided printing on headed paper load the paper into the multi purpose tray with pre-printed side up and top edge into the printer.
 - > For two-sided (duplex) printing on headed paper load the paper with pre-printed side down and top edge away from the printer. (Optional duplex unit must be installed for this function.)
 - > Envelopes should be loaded face up with top edge to the left and short edge into the printer. Do not select duplex printing on envelopes.
 - > Do not exceed the paper capacity of about 100 sheets or 10 envelopes. Maximum stacking depth is 10mm.
5. Press the tray latch button inwards to release the paper platform, so that the paper is lifted and gripped in place.

Set the correct paper size for the multi purpose tray in the Media Menu (see ["Menu functions"](#) on page 16).

OPERATION

USING THE MACHINE

- > For full details of how to use the machine and any optional accessories to print jobs efficiently and effectively, please refer to the **Printing Guide** and the **Barcode Guide**.
- > For full details of how to access and use the printer security features, please refer to the **Security Guide**.
- > For full details of how to connect and use the network feature, please refer to the **Network Guide**.

MENU FUNCTIONS

This section lists the menus accessed via the controls on the printer's operator panel and displayed in the LCD window.

OPERATOR PANEL:

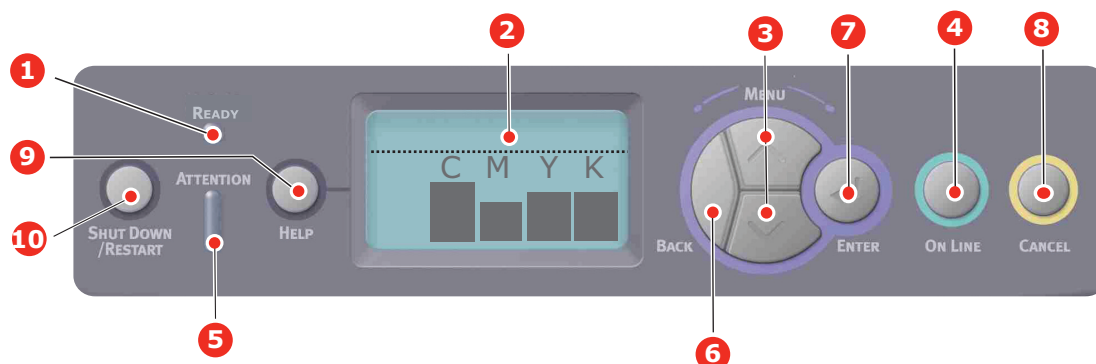

1. Ready LED	ON: Ready to receive data. BLINKING: Processing data. OFF: Offline.	2. Display	Displays the printer status and any error messages.
3. Menu Scroll Buttons	Enters the Menu mode. In Menu mode, forwards or reverses the menu item displayed. Press for 2 secs. or longer to fast forward or reverse.	4. On Line Button	Switches between ONLINE and OFFLINE . Exits the menu and goes ONLINE when pressed in the Menu mode. Scrolls the HELP screen. Forces printing on the paper currently loaded when pressed with "WRONG PAPER" or "WRONG PAPER SIZE" displayed.
5. Attention LED	ON: A warning occurs. Printing may be possible (e.g. low toner). BLINKING: An error occurs. Printing not possible (e.g. toner empty). OFF: Normal condition.	6. Back Button	Returns to the previous higher level menu item.
7. Enter Button	In the ONLINE or OFFLINE mode: enters the Menu mode. In the Menu mode: determines the setting selected.	8. Cancel Button	Deletes the data being printed or received when pressed for two seconds or longer. Deletes the data when pressed for two seconds or longer with WRONG PAPER SIZE, RUN OUT OF PAPER, TRAY 1 IS OPEN, or TRAY 1 IS NOT FOUND is displayed. Exits the menu and goes ONLINE when pressed in the Menu mode.
9. Help Button	Provides advice when an error such as incorrect paper size occurs	10. Shut Down/Restart Button	Carries out the correct shutdown/restart procedure to prevent possible machine damage

HOW TO CHANGE THE SETTINGS - USER

It should be noted that many of these settings can be, and often are, overridden by settings in the Windows printer drivers. However, several of the driver settings can be left at "Printer Setting", which will then default to the settings entered in these printer menus.

Where applicable, factory default settings are shown in bold type in the following tables.

In the normal operating condition, known as "standby," the printer's LCD window will show "Ready to Print". In this condition, to enter the menu system, press the up and down Menu buttons on the operator panel to move up and down through the list of menus until the menu you wish to view is displayed. Then proceed as follows:

1. Press **Enter** to enter the menu.
2. Use the **up and down** MENU buttons on the control panel to scroll through the menus. When the item you want to change is displayed, press **Enter** to view the sub-menus for that item.
3. Use the **up and down** MENU buttons to move up and down through the sub-menu items. When the item you want to change is displayed press Enter to display the setting.
4. Use the **up and down** MENU buttons to move up and down through the available settings for the sub-menu item. When the item you want to change is displayed press **Enter** to display the setting. An asterisk (*) will appear next to the setting, indicating that this setting is currently in effect.
5. Do one of the following:
 - > Press **Back** again to move up to the list of menus;
 - or...
 - > Press **On Line** or **Cancel** to exit from the menu system and return to standby.

HOW TO CHANGE THE SETTINGS - ADMINISTRATOR

You can set whether to **ENABLE** or **DISABLE** each category in the user menu.

Disabled categories are not displayed in the User's menu. Only a system administrator can change these settings.

1. Turn **OFF** the printer. Turn **ON** the printer while pressing the Enter button. When **Boot Menu** appears, take your finger off the button.
2. Press the **Enter** button.
3. When **Enter Password** appears, press the **up or down** MENU button, each time followed by Enter, then **Enter** several times to input the 1st line of the your password, and then press the **Enter** button.
Enter your 4 to 9 digit password.
(The default password is aaaaaa).
4. Press the **Enter** button.
5. Press the **up and down** MENU button until the "category" you want to change is displayed.
6. When it is, press the **Enter** button.
7. Press the MENU **up** button or MENU **down** button until the "item" you want to change is displayed.
8. When it is displayed, press the **Enter** button.
9. Using the MENU **up** button or MENU **down** button, identify the parameter as required.
10. Press the **Enter** button to enter an asterisk (*) on the right side of the setting selected.
11. Press the **On Line** button to switch to online. The machine will automatically re-boot.

CONFIGURATION MENU

ITEM	ACTION	EXPLANATION
Page Count	Tray1 Tray 2* Tray 3* MPT Tray *Note: Only available when optional trays are present	Select an item to display the total number of pages printed from the relevant tray.
Supplies Life	Cyan Drum Magenta Drum Yellow Drum Black Drum Belt Fuser Cyan Toner Magenta Toner Yellow Toner Black Toner	Select item to display the percentage of a consumable remaining.
Network	Printer Name Short Printer Name IP Address Subnet Gateway MAC Address Network FW Version Web Remote version	Displays the full printer name. Displays an abbreviated version. Displays the IP Address Subnet of the network. Displays the Gateway of the network. Displays the Mac Address of the printer. Displays the Network firmware revision. Displays the Web remote version.
System	Serial Number Asset Number Lot Number CU Version PU Version Total Memory Flash Memory HDD	Displays information for these items.

PRINT INFORMATION MENU

This menu provides a quick method of listing various items stored within the printer.

ITEM	ACTION	EXPLANATION
Configuration	Execute	Select execute to print out a configuration report.
Network	Execute	Scroll down to this parameter and select execute to print out Network information.
Demo Page Demo 1	Execute	Scroll down to this parameter and select execute to print out a demonstration page.
File List	Execute	Scroll down to this parameter and select execute to print out a list of job files. (displayed only if FileSystem is installed).
PS font List	Execute	Scroll down to this parameter and select execute to print out a Postscript emulation typeface list.
PCL font List	Execute	Scroll down to this parameter and select execute to print out a PCL font list.
IBM PPR Font List	Execute	Scroll down to this parameter and select execute to print out an IBM PPR font list.
EPSN FX Font List	Execute	Scroll down to this parameter and select execute to print out an Epson FX emulation font list.
Usage Report	Execute	Scroll down to this parameter and select execute to print out a list of colour and mono pages printed.
Error Log	Execute	Scroll down to this parameter and select execute to print out the error log.
Color Profile List	Execute	Scroll down to this parameter and select execute to print out a list of colour profiles.

PRINT SECURE JOB

*NOTE:
Only present if an optional Hard disk Drive (HDD) is fitted.*

ITEM	ACTION	EXPLANATION
Encrypted Job	Not Found Print Delete	<p>Used for printing an encrypted authentication print job (Encrypted Job) stored in HDD.</p> <p>After inputting a password, "Searching Job" is displayed until a job appropriate for the password is found.</p> <p>(Searching time increases in proportion to the number of jobs stored in HDD, and the printer may take up to 20 sec.)</p> <p>The search can be cancelled by holding down the Cancel button.</p> <p>Not Found will be displayed where a file, which could be printed is not available.</p> <p>The following message will appear if a printable file is available.</p> <p>Encrypted Job</p> <p>Print</p> <p>Delete</p> <p>A set of all jobs will be printed if Print is selected and the Enter button is pressed.</p> <p>The following message will appear if Delete is selected:</p> <p>Are You Sure?</p> <p>Yes</p> <p>No</p> <p>The display will return to the source menu if No is selected.</p> <p>All jobs will be deleted if Yes is selected.</p> <p>Print jobs with encrypted authentication stored in HDD are deleted by a delete method specified by the driver after printing or a delete instruction from the menu.</p>
Stored Job	Not Found Print Delete	<p>Used to print out a stored job in a HDD.</p> <p>Not Found will be displayed where a file, which could be printed is not available.</p> <p>The following message will appear if a printable file is available.</p> <p>Stored Job</p> <p>Print</p> <p>Delete</p> <p>When Print is selected, Set Collating Amount is displayed and the number of pages to print can be specified.</p> <p>Specify the number of pages to print and press the Enter button.</p> <p>The following message will appear if Delete is selected:</p> <p>Are You Sure?</p> <p>Yes</p> <p>No</p> <p>If No is selected, the display will return to the previous menu.</p> <p>If Yes is selected, all jobs will be deleted.</p>

MENUS

ITEM	ACTION	EXPLANATION
Tray Configuration	Paper feed Default: Tray 1	Select tray (default condition indicated by *) Select by scroll and Enter button.
	Auto Tray Switch Default: On	Switches Auto ON/OFF (default condition indicated by *). Select by scroll and Enter button.
	Tray Sequence Default: Down	Selects Tray sequence Down/Up/Paper feed Tray (default condition indicated by *). Select by scroll and Enter button.
	Unit of Measurement Default: millimeter	Selects UOM Inches or millimeter (default condition indicated by *). Select by scroll and Enter button.
	Tray1 Configuration Default: Paper size: Cassette /Custom Media Type: Plain /Letterhead/ Bond/recycled/ Card stock/ Rough/Glossy/ *User type 1-5 Media Weight: Light /Medium Light/Medium/ Heavy/Ultra Heavy1	Configure Paper Size/Media Type/Media Weight . Defines default condition (indicated by *) Select by scroll and Enter button. *User type 1 to 5 are displayed only if registered in the host PC.

ITEM	ACTION	EXPLANATION
Tray Configuration (cont.)	<p>MPT Tray Configuration</p> <p>Paper size: A4/A5/A6/B5/ Legal14/Legal 13.5/ Legal13/Letter/ Executive/Custom/ Com-9 Envelope/ Com-10 Envelope Monarch Envelope DL Envelope/C5</p> <p>Media Type: Plain/ Letterhead/ Transparency/ Labels/Bond/ Recycled/Card Stock/Rough/ Glossy/ Usertype 1-5 Media</p> <p>Weight: Light/Medium Light/Medium/ Heavy/ Ultra Heavy 1/ Ultra Heavy 2</p> <p>Tray usage: Do Not Use/ When Mismatching</p>	<p>Configure Paper Size/Media Type/Media Weight/Tray Usage. Defines default condition (indicated by *) Select by scroll and Enter button.</p> <p>User type 1 to 5 are displayed only if registered in the host PC.</p> <p>Paper weight 189 ~ 220g/m²</p> <p>Sets MPTray usage.</p> <p>When Mismatching: if paper mismatch occurs, paper is requested from the MPTray instead of the specified tray.</p> <p>Do Not Use: sets MPTray unavailable both in Auto Tray Select and Auto Tray Switch.</p>
	<p>Tray 2 Config*</p> <p>Tray 3 Config*</p>	<p>*Note: only present if option installed</p>

ITEM	ACTION	EXPLANATION
System Adjust	Power Save Time Default: 5	Select from 5/10/15/30/60 Minutes (default condition indicated by *). Select by scroll and Enter button.
	Clearable Warning Default: ONLINE	Select from: ONLINE/Job (default condition indicated by *). Select by scroll and Enter button. PS job only.
	Auto Continue Default: Off	Select from On/Off (default condition indicated by *). Select by scroll and Enter button.
	Manual Timeout Default: 60	Select from Off/30 seconds/60 seconds (default condition indicated by *). Select by scroll and Enter button.
	Wait Timeout Default: 40	Select from Off/5/10/20/30/40/50/60/90/120/150/180/210/240/270/300 seconds (default condition indicated by *). Select by scroll and Enter button.
	Low Toner Default: Continue	Select action to take when toner sensor indicates low toner. Select from Continue/Stop (default condition indicated by *). Select by scroll and Enter button.
	Jam Rcovery Default: On	Select from On/Off (default condition indicated by *). Select by scroll and Enter button.
	Error Report Default: Off	Select from On/Off (default condition indicated by *). Select by scroll and Enter button.
	Print Position Adjust Default: 0.00	Select from X Adjust/Y Adjust/Duplex X Adjust/Duplex Y adjust (default condition indicated by *). Select by scroll and Enter button. Define measurement.
	Paper Black Settings -2/-1/0/+1/+2 Default: 0	Used for fine adjustment of the black print on paper.
	Paper color Settings -2/-1/0/+1/+2 Default: 0	Used for fine adjustment of the colour print on paper.
	Trans. Black Settings -2/-1/0/+1/+2 Default: 0	Used for fine adjustment of the black print on transparencies.
	Trans. color Settings -2/-1/0/+1/+2 Default: 0	Used for fine adjustment of the colour print on transparencies.
	SMR Setting +3/+2/+1/-1/-2/-3/ Default: 0	To correct variations in print results caused by temperature/humidity conditions and difference in print density/frequency. Change the setting when print quality is uneven.
	BG Setting +3/+2/+1/-1/-2/-3/ Default: 0	To correct variations in print results caused by temperature/humility conditions and difference in print density/frequency. Change the setting when background is dark.

ITEM	ACTION	EXPLANATION
System Adjust (cont.)	Drum Cleaning Default: Off	Sets whether to rotate the drum in idle prior to printing in order to reduce horizontal white lines. Be warned that this will shorten the ID life by as much as this rotation (default condition indicated by *). Select by scroll and Enter button.
	Hex Dump Execute	Prints out data received from the host PC in the hexadecimal Dump. Turning off the power supply switch restores Normal Mode.

SHUTDOWN MENU

This menu only appears if the hard disk drive is installed.

This item should always be selected before switching the printer off, to ensure that no hard disk data is lost.

ITEM	SETTINGS	EXPLANATION
Shutdown Start	Execute	Performs controlled shutdown of the printer, ensuring that all files on the internal hard disk are closed before power is turned off. Only power the printer off when the display indicates that shutdown is complete.

ADMIN SETUP

ITEM		SETTINGS	EXPLANATION
Enter Password		xxxxxxxxxxxx	Enter a password to gain entry to the Admin Setup menu. Password should be from 6 to 12 digits of alpha/numeric characters (or mix) The default value is "aaaaaa"
Network Setup	TCP/IP	Enable Disable	Sets TCP/IP Protocol. Enable: TCP/IP Protocol is available. Disable: TCP/IP Protocol is not available.
	IP Version	IP v4 IP v4+v6	Set up the IP version. Operates with IPv4 for IPv4 (not valid with IPv6). Operates with both IPv4 and IPv6
	NetBEUI	Enable Disable	Sets Enable/Disable of NETBEUI Protocol.
	NetWare	Enable Disable	Sets Enable/Disable of NetWare Protocol.
	EtherTalk	Enable Disable	Sets Enable/Disable of EtherTalk Protocol.
	Frame Type	Auto 802.2 802.3 Ethernet II SNAP	Sets the frame type. Netware should be enabled.
	TypeIP Address Set	Auto Manual	Sets the IP Address setting method. TCP/IP should be enabled.
	IP Address	xxx.xxx.xxx.xxx	Sets the IP Address. TCP/IP should be enabled.
	Subnet Mask	xxx.xxx.xxx.xxx	Sets the Subnet Mask. TCP/IP should be enabled.
	Gateway Address	xxx.xxx.xxx.xxx	Sets the Gateway (default router) address. 0.0.0.0 means that there is no router. TCP/IP should be enabled.
	Web	Enable Disable	Sets Enable/Disable of Web. Enable: Web/IPP is available. Disable: Web/IPP is not available. TCP/IP should be enabled.
	Telnet	Enable Disable	Sets Enable/Disable of Telnet. Enable: Telnet is available. Disable: Telnet is not available. TCP/IP should be enabled.
FTP	Enable Disable	Sets Enable/Disable of FTP. Enable: FTP is available. Disable: FTP is not available. TCP/IP should be enabled.	

ITEM		SETTINGS	EXPLANATION
Network Setup (cont.)	SNMP	Enable Disable	Sets Enable/Disable of SNMP. Enable: SNMP is available. Disable: SNMP is not available. TCP/IP or NetWare should be enabled.
	Network Scale	Normal Small	When Normal is selected, the network can work effectively even when it is connected to a HUB that has a spanning tree feature. However, printer start up time gets longer when computers are connected with two or three small LANs. When Small is selected, computers can cover from two or three small LANs to a large LAN, but may not work effectively when the network is connected to a HUB with a spanning tree feature.
	Hub Link Setting	Auto Negotiate 100Base-TX Full 100Base-TX Half 10Base-T Full 10Base-T Half	Sets a method to link to a HUB. When Auto is set, a connection method to a HUB is selected automatically.
	Factory Defaults?	Execute	Specifies whether to initialize the network factory default settings for the Network.
Print Setup	Personality	Auto PostScript PCL IBM PPR EPSON FX	Selects a printer language.
	Copies	1 - 999	Selects the default number of copies.
	Duplex	On/Off	Specifies Duplex print (option) if a Duplex unit is installed and enabled
	Binding	Long Edge Short Edge	Specifies Binding in duplex printing (if a Duplex unit is installed and enabled)
	Media Check	Enable Disable	Sets whether the printer checks the matching of printed data size and that of the tray. Only standard sizes are checked.
	Resolution	600dpi 600x1200dpi 600dpi multi-level.	Sets default resolution.
	Toner Save Mode	On/Off	This function works effectively only if the data input is color RGB data. This setting is valid in PS and PCL, but does not take effect in the following cases. (1) PS: If Color Matching is set OFF. (2) PS: If any setting other than ASIC Color Matching is set. (3) PS: CMYK data when Ink Simulation Mode is used (valid in any other cases except Case (1) and Case (2) above as long as data is RGB). (4) PCL binary data (Color/Monochrome).

ITEM		SETTINGS	EXPLANATION
Print Setup (cont.)	Mono-Print Speed	Auto Color Speed Normal Speed High Quality	Sets the monochrome print speed. Prints at the most appropriate speed for page process if Auto is set. Prints always at the color print speed if Color is set. Prints always at the monochrome print speed if Normal is set. Prints always at 26ppm of the gradation print speed for both color and monochrome print if High Quality is set.
	Default Orientation	Portrait Landscape	Specifies print orientation. Not valid for PS (valid only for PCL/ IBMPPR/EPSONFX/ HP-GL2).
	Form Length	5 lines ~ 60 lines ~ 128 lines	Sets the number of lines that can be printed on a page Not valid for PS (valid only for PCL/HP-GL2). Default values listed to the left are for Letter/A4. In practice, however, they change according to the size of paper loaded in the tray.
	Edit Size	Cassette Size/ Letter/ Executive/ Legal14/ Legal13.5/ Legal13/A4/A5/ A6/B5/Custom/ C5/Com-10 Envelope/ Monarch Envelope/DL Envelope/C5/ Com-9 Envelope	Sets the size of an area to draw when the host PC does not specify the size via the paper edit size designating command (Not valid for PS - only for PCL).
	Trapping	Off Narrow Wide	Trapping, or spreading and choking, is a prepress technique consisting of creating small overlaps between abutting colors in order to mask registration issues in the graphical production.
	Trapping X Width	0 pixels ~ 4 pixels	Sets the horizontal dimension of the trapping area.
	Trapping Y Width	0 pixels ~ 4 pixels	Sets the vertical dimension of the trapping area.
	X Dimension	64 mm ~ 210 mm ~ 216 mm	Specifies paper width of Custom paper as a default value. Sets a paper size at right angles to the paper run direction.
	Y Dimension	127 mm ~ 297 mm ~ 1220 mm	Specifies paper length of Custom paper as a default value. Sets a paper size in the same direction as the paper run direction.

ITEM		SETTINGS	EXPLANATION
PS Setup	Network Protocol	ASCII/ RAW	Specifies PS communication protocol mode of data from NIC port. (In RAW mode, Ctrl-T is invalid). PS models only.
	Parallel Protocol	ASCII /RAW	Specifies PS communication protocol mode of data from Centronics port. (In RAW mode, Ctrl-T is invalid). PS models only.
	USB Protocol	ASCII/ RAW	Specifies PS communication protocol mode of data from USB port. (In RAW mode, Ctrl-T is invalid). PS models only.
PCL Setup	Font Source	Resident	Specifies the location of PCL default font.
	Font Number	10 ~ I90	Sets the PCL font number. The valid range of this variable changes depending on the FONT SOURCE setting at the time. If the default font is set for FONT SOURCE, the number starts at 0. If it is not, the number starts at 1. The maximum value is equal to the number of fonts installed in FONT SOURCE.
	Font Pitch	99.9 CPI ~ 10.00 CPI ~ 0.44 CPI	Width of the PCL default font in characters per inch (CPI). Default font is fixed-pitch, scalable font. The value of pitch is displayed down to the second decimal place. Displayed only when the font selected in Font No. is a fixed-spacing, scalable font.
	Symbol Set	PC-8	Sets the symbol set of PCL (see machine operator panel for complete list).
	A4 Print Width	78 column 80 column	Sets the number of characters for A4 paper. Auto LF. This is for 10-CPI characters when Auto CR/LF Mode is set to OFF. This menu is enabled only when A4 paper is selected in the menu that sets the print width of A4 paper in portrait orientation. Usually, such A4 paper print width is set slightly narrower than 8 inches (about 7.93 inches). This setting cannot print 80 10-cpi characters (only prints up to 78 10-cpi characters). 80 characters set at A4 Print Width widen the right and left margins. A PCL command selects or selects/deselects Auto CR/LF mode.
	White Page skip	On/ Off	Sets whether to eject a page without any data to print (blank page) upon reception of FF command (OCH) in PCL Mode. OFF: Ejecting.
	CR Function	CR /CR+LF	Sets action when CR code is received in PCL. CR: Carriage Return CR+LF: Carriage Return and Line Feed
	LF Function	LF /LF+CR	Sets action when LF code is received in PCL. LF: Line Feed LF+CR: Line Feed and Carriage Return
	Print Margin	Normal 1/5 inch 1/6 inch	Sets a non-printable area of paper. The width of the area along the right and left sides of paper (left and right sides depend on paper orientation). NORMAL: PCL emulation compatible, approximately 1/4~1/4.3INCH (depending on paper) is outside the printable area.

ITEM		SETTINGS	EXPLANATION
PCL Setup (cont.)	True Black	On/Off	Sets whether to use Composite Black (cmyk mixed) or Pure Black (K only) for the black (100%) in image data. OFF: Mode using Composite Black ON: Mode using Pure Black (PCL only)
	Pen Width Adjust	On/Off	When minimum width is specified in PCL, sometimes a 1-dot line, looks broken. With PEN WIDTH Adjust set to ON, when the minimum width is specified, the line width will be emphasized so as to look wider than a 1-dot line. With PEN WIDTH Adjust set to OFF, the line will appear as before.
	Tray 2 ID#	1 ~ 5 ~ 59	Sets the # to specify Tray 2 for the paper feed destination command (ESC&I#H) in PCL5e emulation. (Displayed only if Tray 2 is installed).
	Tray 3 ID#	1 ~ 20 ~ 59	Sets the # to specify Tray 3 for the paper feed destination command (ESC&I#H) in PCL5e emulation. (Displayed only if Tray 3 is installed).
	MPTray ID#	1 ~ 4 ~ 59	Sets the # to specify the MP tray for the paper feed destination command (ESC&I#H) in PCL5e emulation.

ITEM		SETTINGS	EXPLANATION
IBM PPR Setup	Character Pitch	10 CPI 12 CPI 17 CPI 20 CPI Proportional	Specifies character pitch in IBM PPR emulation.
	Font Condense	12CPI to 20CPI 12CPI to 12CPI	Specifies 12CPI pitch for Condense Mode.
	Character Set	SET-2 SET-1	Sets a character set.
	Symbol Set	IBM 437	Sets the Symbol Set for IBM PPR (see machine operator panel for complete list).
	Letter O Style	Enable/ Disable	Specifies the style that replaces ø (9B) and ¥ (9D) with ø (ou) and Ø (zero).
	Zero Character	Normal /Slashed	Specifies the style of 0(zero). SLASHED: SLASH ZERO
	Line Pitch	6/8 LPI	Sets line space.
	White Page Skip	On/ Off	Sets whether to eject a blank sheet. Available only when simplex is set.
	CR Function	CR /CR+LF	Sets action when CR code is received.
	LF Function	LF /LF+CR	Sets action when LF code is received.
	Line Length	80 /136 Column	Specifies the number of characters per line.
	Form Length	11/ 11.7 /12 inch	Specifies the length of paper.
	TOF Position	0.0 /0.1/~1.0 inch	Sets the position from the top edge of paper.
	Left Margin	0.0 /0.1/~1.0 inch	Sets the amount to shift the horizontal print start position to the right.
Fit to Letter	Enable/ Disable	Sets the printing mode that can fit print data, equivalent to 11 inches (66 lines), in the LETTER-size printable area.	
Text Height	Same /Diff	Sets height of a character. SAME: Regardless of CPI, same height DIFF: According to CPI, character heights vary.	

ITEM		SETTINGS	EXPLANATION
EPSON FX Setup	Character Pitch	10 CPI /12 CPI/ 17 CPI 20 CPI/ Proportional	Specifies character pitch in Epson FX emulation.
	Character Set	SET-2 SET-1	Sets a character set.
	Symbol Set	IBM 437	Sets the Symbol Set for Epson FX Emulation. (see machine operator panel for complete list).
	Letter O Style	Enable/ Disable	Specifies the style that replaces ø (9B) and ¥ (9D) with ø (ou) and Ø (zero).
	Zero Character	Normal /Slashed	Specifies the style of 0(zero). SLASHED: SLASH ZERO
	Line Pitch	6/8 LPI	Sets line space.
	White Page Skip	On/ Off	Sets whether to eject a blank sheet. Available only when simplex is set.
	CR Function	CR /CR+LF	Sets action when CR code is received.
	Line Length	80 /136 Column	Specifies the number of characters per line.
	Form Length	11/ 11.7 /12 inch	Specifies the length of paper.
	TOF Position	0.0 /0.1/~1.0 inch	Sets the position from the top edge of paper.
	Left Margin	0.0 /0.1/~1.0 inch	Sets the amount to shift the horizontal print start position to the right.
	Fit to Letter	Enable/ Disable	Sets the printing mode that can fit print data, equivalent to 11 inches (66 lines), in the LETTER-size printable area.
	Text Height	Same /Diff	Sets height of a character. SAME: Regardless of CPI, same height DIFF: According to CPI, character heights vary.
Color Setup	Ink Simulation	Off SWOP Euroscale Japan	The machine has its own process simulation engine which simulates standard colors in the printer. This function is available only with PS language jobs.
	UCR	Low Medium High	Selects limitation to the toner layer thickness. If paper curl occurs in dark printing, selecting MEDIUM or LIGHT sometimes helps reduce this curl. UCR = Under Color Removal.
	CMY 100% Density	Enable/ Disable	Enable/Disable 100% output against the CMY100% TRC compensation. Ordinarily, the TRC compensation function holds control for the appropriate print density; thus 100% output is not always possible. Selecting ENABLE will enable 100% output in any individual color. The actual print, including the TRC compensation function is limited to an appropriate area. This function is for special purposes such as specification in CMYK color reduction in PS.
	CMYK Conversion	On /Off	Setting to "OFF" will simplify the conversion process of CMYK data, which will reduce the processing time. This setting is ignored when Ink Simulation function is used. PS only

ITEM		SETTINGS	EXPLANATION
Memory Setup	Receive Buffer Size	Auto 0.5 megabyte 1 megabyte 2 megabyte 4 megabyte 8 megabyte 16 megabyte	Sets the size of receive buffer
	Resource Save	Auto Off 0.5 megabyte 1 megabyte 2 megabyte 4 megabyte 8 megabyte 16 megabyte	Sets the size of resource saving area.
HDD Setup	This item is displayed only if a HDD (option) is installed.		
	Initialize	Execute	Initializes the HDD to the factory default setting. Machine performs partition-division, and initializes each partition. When this menu is executed, the following confirmation message appears. Are You Sure? Yes/No If No is selected, you will return to the previous menu. If Yes is selected, the following confirmation message appears. Execute Now? Yes/No If No is selected, you will return to the previous menu. The request to execute HDD initialization is put into the memory and initialization will be executed at the next power cycle. If Yes is selected, shutdown takes place, and the HDD is initialized at power Off/On cycle.

ITEM		SETTINGS	EXPLANATION
HDD Setup (cont.)	Resize Partition	PCL nn%/ Common mm%/ PSll%/<Apply>	<p>Specifies the size of partition. Specifies a size by ratio to the whole HDD in % (1% unit). nn,mm,ll: 1 - 98 and nn+mm+ll=100</p> <p>The sizes are displayed in the partition list and can be changed by selecting the partition size to be changed. If Apply is selected, the following confirmation message appears.</p> <p>Are You Sure? Yes/No If No is selected, you will return to the previous menu. If Yes is selected, the following confirmation message appears.</p> <p>Execute Now? Yes/No If No is selected, you will return to the previous menu. The request to execute the partition size change request is put into the memory and the hard disk initialization and partition size change will be executed at next power cycle.</p> <p>If Yes is selected, shutdown takes place. Hard disk initialization and partition size change will be executed at Power Off/On cycle. (If one partition size is modified, the others are also modified.) If any partition size is modified, Initialization of HDD needs to be executed as well.</p> <p>If a previously used HDD is installed, HDD initialization also takes place. If a HDD, which has been used before, is installed, the layout of this menu may be different from that of each partition. (The previously used layout will be displayed.)</p> <p>In Non-PS machines, PS is replaced by COMMON, so the message is displayed as "PCL/COMMON/COMMON".</p>
	Format Partition	PCL Common PS	<p>Formats a specified partition.</p> <p>When the Enter button is pressed, the following confirmation message appears.</p> <p>Are You Sure? Yes/No If No is selected, you will return to the previous menu. If Yes is selected, the following confirmation message appears.</p> <p>Execute Now? Yes/No If No is selected, you will return to the previous menu. The request to execute partition formatting is put into the memory and formatting will be executed at next power cycle.</p> <p>If Yes is selected, shutdown takes place and the partition is formatted at power Off/On cycle.</p> <p>In Non-PS machines, PS is replaced by Common, so the message is displayed as "PCL/Common/Common".</p>
System Setup	Near Life LED	Enable/Disable	<p>Controls the settings of the Attention LED when near end of life warning of toner, drum, fuser, or belt occurs.</p> <p>Attention LED is lit when enabled, not lit if disabled. (Displays LCD message.)</p> <p>The temporary recovery by opening and closing of the cover in Life error is not included.</p>
	Reset Section Counter	Execute	<p>Resets the section counter of print statistics function to zero.</p> <p>If Execute is selected, exits from the menu.</p>

ITEM		SETTINGS	EXPLANATION
Change Password	New Password	xxxxxxxxxxxxxx	Sets a new password to enter Admin Setup menu From 6 to 12 alpha/numeric digits can be entered.
	Verify password	xxxxxxxxxxxxxx	Forces the User to input the new password to enter Admin Setup. From 6 to 12 alpha/numeric digits can be entered.
Settings	Reset Settings	Execute	Resets EEPROM of CU. Resets User menu to the factory default. If Execute is selected, exits from the menu.
	Save Settings	Execute	Saves menus currently set. With this function, the menus with which operation was last performed are saved, and overwrites with them menus that were previously saved. When the Enter button is pressed, the following confirmation message appears. Are You Sure? Yes/No When No is selected, the preceding menus are restored. When Yes is selected, the current menu settings are saved and this menu is exited.

CALIBRATION

ITEM		SETTINGS	EXPLANATION
Auto Density		On/Off	Enables/disables automatic density adjustment.
Adjust Density		Execute	If Execute is selected, the printer will immediately adjust density and reflect it in TRC compensation. This adjustment must be executed when the printer is idling. It can become invalid if executed in any other state.
Adjust Registration		Execute	When this menu is selected, the printer performs AutoAdjust Registration. This adjustment must be executed when the printer is idling.
Print Tuning Pattern		Execute	Prints the pattern for the user to adjust TRC. Ordinarily, this function is not needed because TRC is automatically adjusted to the recommended levels through density adjustment and TRC compensation. Adjustment results will be reflected as offset values (addition) to the corrections through the Adjust Density/TRC Compensation function.
Cyan/Magenta/ Yellow/Black Tuning	Highlight	-3,-2,-1, 0 ,+1,+2,+3,	Adjusts HIGHLIGHT (light area) of the TRC. + = Darker - = Lighter
	Mid-Tone	-3,-2,-1, 0 ,+1,+2,+3,	Adjusts MID-TONE area of the TRC. + = Darker - = Lighter
	Dark	-3,-2,-1, 0 ,+1,+2,+3,	Adjusts DARK area of the TRC. + = Darker - = Lighter
Cyan/Magenta/ Yellow/Black Darkness		-3,-2,-1, 0 ,+1,+2,+3,	Adjusts the engine density. The Darkness settings for each of CMYK will be reflected as offset values (addition) to the corrections through the Adjust Density/TRC Compensation function.

PRINT STATISTICS

ITEM	SETTINGS	EXPLANATION
Enter Password	XXXX	Enters a password to enter Print Statistics menu. The default value is "0000". The password for entry to Print Statistics is different from the password for entry to Functions-Admin Setup. "Print Statistics" category is not shown when Print Statistics function is not supported.
Section Counter	Enable /Disable	Specifies if the section counter is displayed in Usage Report Print or not. Enable: Displayed, Disable: Not displayed. Enable must be selected in Functions/Print Statistics/Usage Report
Reset Group Counter	Execute	Resets the main counter to zero. When executing this menu, resets the main counter to zero and exits from the menu. Enable must be selected in Functions/Print Statistics/Usage Report.

ITEM	SETTINGS	EXPLANATION
Group Counter	Enable/Disable	Specifies if the Group counter is displayed in the Usage Report Print. Enable: Displayed, Disable: Not displayed. Conditions for display: Enable must be selected in Functions/Print Statistics/Usage Report.
Usage Report	Enable/ Disable	Enables/Disables the printing of the Usage Report. When changing a setting value, the printer is rebooted.
Change Password		Changes the password. Enable must be selected in Functions/Print Statistics/Usage Report
New Password	xxxx	Sets a new password to enter Print Statistics menu.
Verify Password	xxxx	Re-enter new password set to enter Print Statistics set in New Password for confirmation.

ADMINISTRATOR (BOOT) MENU

This menu is only accessible to System Administrators. In order to gain access to this menu, follow the instructions in ["How to change the settings - Administrator" on page 17](#).

This menu is in ENGLISH only (default settings in bold type).

Parallel Setup

This menu controls the operation of the printer's Parallel data interface.

ITEM	SETTINGS	EXPLANATION
Enter Password	xxxxxxxxxxxx	Enter a password to gain entry to the Admin menu. Password should be from 6 to 12 digits of alpha/numeric characters (or mix) The default value is "aaaaaa" The printer will restart after the Boot Menu.
Parallel	Enable / Disable	Enables or disables the parallel port.
Bi-direction	Enable / Disable	ENABLE/DISABLE the bi-directional capability of the parallel interface.
Ecp	Enable / Disable	Extended Capabilities Port, enables/disables this function.
Ack Width	Narrow / Medium/ Wide	Sets ACK width for compatible reception. = 0.5µs = 1.0µs = 3.0µs
Ack / Busy Timing	Ack In Busy / Ack While Busy	Sets the order to output the BUSY and ACK signal for compatible reception.
I-prime	Disable / 3µsec/50µsec	Sets time to enable/disable I-prime signal
Offline Receive	Enable / Disable	To Enable/disable of this function. When set to Enable, the interface retains a receive possible state even when switching to Offline. Interface sends the BUSY signal only when the receive buffer is full or a service call occurs.

USB Setup

This menu controls the operation of the printer's USB data interface.

ITEM	SETTINGS	EXPLANATION
Usb	Enable / Disable	ENABLES / DISABLES the USB port.
Speed	12 / 480 Mbps	Selects the interface speed. After setting change the menu, the printer restarts on exit.
Soft Reset	Enable / Disable	Enables or disables the SOFT RESET command.
Offline Receive	Enable / Disable	OFFLINE RECEIVE.
Serial Number	Enable / Disable	Specifies whether to ENABLE or DISABLE a USB serial number. The USB serial number is used to identify the USB device connected to your PC.

When you have changed any settings in the USB MENU, turn the printer **OFF**, then **ON** again.

Security Setup

Only available when a Hard Disk (option) is fitted.

ITEM	SETTINGS	EXPLANATION
Job Limitations	Off Encrypted Job	Job limitation mode control. Jobs other than specified ones are rejected.
Reset Cipher Key	Execute	Resets a cipher key to be used on an encrypted hard disk. When this processing is done, all data stored on the hard disk cannot be restored. After execution, the following confirmation messages will appear. Are You Sure? Yes No If No is selected, the display will return to the previous menu. If Yes is selected, the printer will be automatically rebooted and the resetting of the cipher key will be executed.

Storage System

Only available when a Hard Disk (option) is fitted.

ITEM	SETTINGS	EXPLANATION
Check File System	Execute	Resolves mismatch between actual memory and displayed memory available in a file system. Performs administration data (FAT information) recovery. Performs recovery only for an HDD.
Check All Sectors	Execute	Performs recovery of defective HDD sector information and a file system mismatch mentioned above. The target device is only a HDD and it takes 30 to 40 minutes to complete this function for an HDD of 10GB.
Enable HDD	Yes No	Even if a machine is inoperable at installation because of a faulty HDD, the machine can be made operable by setting this parameter to No (ignores the existence of the HDD). When No is set, access to a HDD results in FAIL because the HDD is regarded as not attached. After setting change and exit from the menu, the printer will restart.

ITEM	SETTINGS	EXPLANATION
Erase HDD	Execute	<p>Deletion of all data stored in the hard disk. DoD 5220.22-M sanitizing formula is used for clearing the desk. The machine will restart after changing setup. The following message appears after pressing the Enter switch.</p> <p>Are You Sure? Yes No</p> <p>If NO is selected, you will be returned to the source menu</p> <p>If Yes is selected the procedure for clearing disk will start immediately after the machine reboots.</p> <p>If the Cancel button is held down during erasing, the following confirmation messages will appear to discontinue processing.</p> <p>Do You Wish to Cancel? Yes No</p> <p>If NO is selected, the procedure will continue. If YES is selected, the procedure will discontinue.</p>
Enable initialization	No Yes	Prevents a setting change accompanying initialization of Block Device (HDD,FLASH).

Power Setup

ITEM	SETTINGS	EXPLANATION
Power Save	Enable Disable	Sets Enable/Disable of Power Save Mode.

Language Setup

ITEM	SETTINGS	EXPLANATION
Language initialize	Execute	<p>Initialises the message file loaded in FLASH.</p> <p>When you press the Enter button, the following message, requesting confirmation, will appear,</p> <p>Are You Sure? Yes No</p> <p>If NO is selected, you will be returned to the source menu.</p> <p>The procedure for clearing the disk will start immediately after the menu and rebooting.</p>

REPLACING CONSUMABLE ITEMS

This section explains how to replace consumable items when due. As a guide, the life expectancy of these items is:

TONER:

Starter Cartridge:

The machine is shipped with sufficient cyan, magenta, yellow and black toner for 4,000 images (ISO/IEC19798 A4).

Replacement Cartridge:

Black: Replacement cartridges have a capacity of approximately 11,000 images (ISO/IEC19798 A4)

C, M & Y: Replacement cartridges have a capacity of approximately 11,500 images (ISO/IEC19798 A4)

IMAGE DRUM:

K Approximately 20,000 A4 pages @ 3 pages per job.

C, M & Y Approximately 15,000 A4 pages @ 3 pages per job.

TRANSFER BELT:

Approximately 60,000 A4 pages @ 5% coverage.

FUSER:

Approximately 60,000 A4 pages @ 5% coverage.

CONSUMABLE ORDER DETAILS

ITEM	LIFE	ORDER NO.
Toner, black	11,000 images	43866108
Toner, cyan	11,500 images	43866107
Toner, magenta	11,500 images	43866106
Toner, yellow	11,500 images	43866105
Image drum, black	20,000 A4 pages	43913808
Image drum, cyan	15,000 A4 pages	43913807
Image drum, magenta	15,000 A4 pages	43913806
Image drum, yellow	15,000 A4 pages	43913805
Fuser	60,000 A4 pages	43854903
Transfer belt	60,000 A4 pages	43363412

Only use genuine Oki Original consumables to ensure the best quality and performance from your hardware. Non Oki Original products may adversely affect your printer's performance and invalidate your warranty.

TONER CARTRIDGE REPLACEMENT

NOTE:

When the LCD display indicates TONER LOW, or if print appears faded, first open the top cover and try tapping the cartridge a few times to evenly distribute the toner powder. This will enable you to obtain the best "yield" from your toner cartridge.

CAUTION!

To avoid toner wastage and possible toner sensor errors, do not change the toner cartridge(s) until "TONER EMPTY" is displayed.

The toner used in this printer is a very fine dry powder. It is contained in four cartridges: one each for cyan, magenta, yellow and black.

Have a sheet of paper handy so that you have somewhere to place the used cartridge while you install the new one.

Dispose of the old cartridge responsibly, inside the pack that the new one came in. Follow any regulations, recommendations, etc., which may be in force concerning waste recycling.

If you do spill any toner powder, lightly brush it off. If this is not enough, use a cool, damp cloth to remove any residue.

Do not use hot water, and never use solvents of any kind. They will make stains permanent.

WARNING!

If you inhale any toner or get it in your eyes, drink a little water or bathe your eyes liberally in cold water. Seek medical attention immediately.

1. Press the cover release and open the printer's top cover fully.

WARNING

If the printer has been powered on, the fuser may be hot. This area is clearly labelled. Do not touch.

- 2.** Note the positions of the four cartridges.

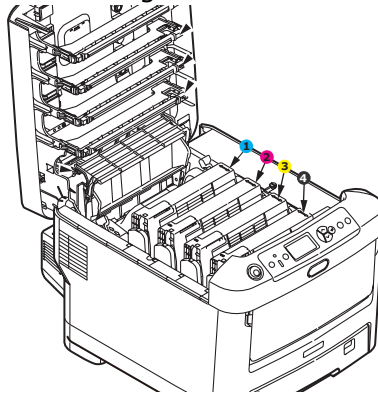

1. Cyan cartridge	2. Magenta cartridge
3. Yellow cartridge	4. Black cartridge

- (a) Pull the coloured toner release lever on the cartridge to be replaced fully towards the front of the printer.

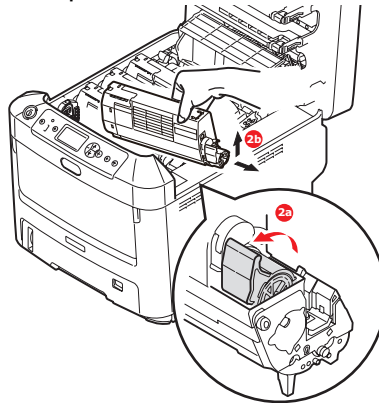

- (b) Lift the right-hand end of the cartridge and then draw the cartridge to the right to release the left-hand end as shown, and withdraw the toner cartridge out of the printer.

- 3.** Clean the top of the ID unit with a clean, lint free cloth.

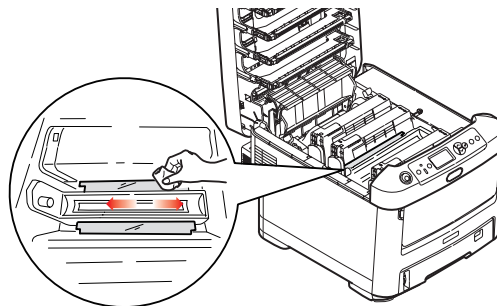

- 4.** Put the cartridge down gently onto a piece of paper to prevent toner from marking your furniture.
- 5.** Remove the new cartridge from its box but leave its wrapping material in place for the moment.

6. Gently shake the new cartridge from end to end several times to loosen and distribute the toner evenly inside the cartridge.

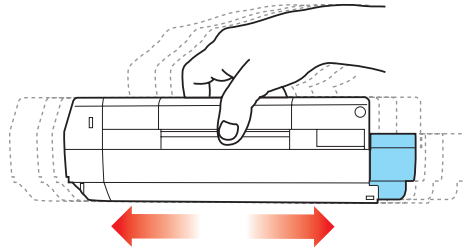

7. Remove the wrapping material and peel off the adhesive tape from the underside of the cartridge.

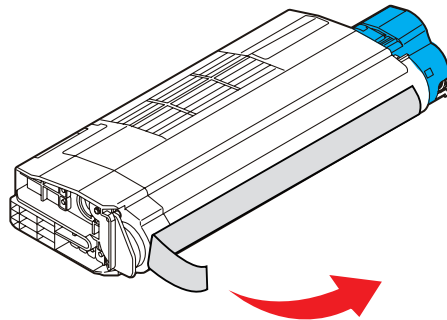

8. Holding the cartridge by its top centre with the coloured lever to the right, lower it into the printer over the image drum unit from which the old cartridge was removed.
9. Insert the left end of the cartridge into the top of the image drum unit first, pushing it against the spring on the drum unit, then lower the right end of the cartridge down onto the image drum unit.

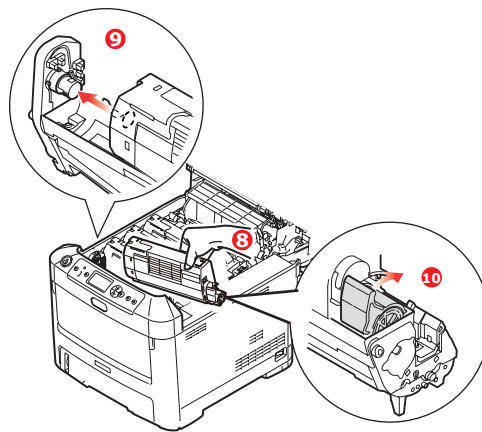

10. Pressing gently down on the cartridge to ensure that it is firmly seated, push the coloured lever towards the rear of the printer. This will lock the cartridge into place and release toner into the image drum unit.

11. Gently wipe the LED head surface with soft tissue.

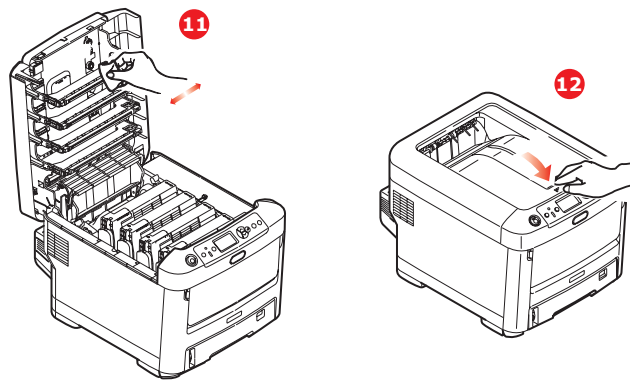

CAUTION!

To avoid toner wastage and possible toner sensor errors, do not change the toner cartridge(s) until "TONER EMPTY" is displayed.

12. Finally, close the top cover and press down firmly at both sides so that the cover latches closed.

IMAGE DRUM REPLACEMENT.

CAUTION!



Static sensitive devices, handle with care.

The printer contains four image drums: cyan, magenta, yellow and black.

1. Press the cover release and open the printer's top cover fully.

WARNING!

If the printer has been powered on, the fuser will be hot. This area is clearly labelled. Do not touch.

2. Note the positions of the four toner cartridges (a) and image drums (b). It is essential that they go back in the same order.

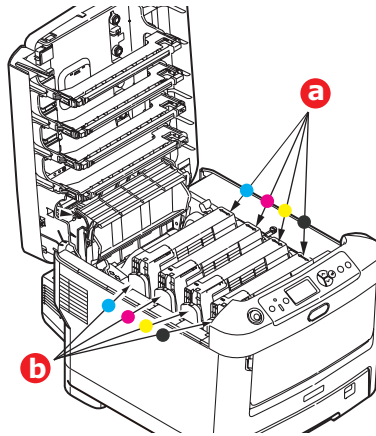

3. Holding it by its top centre, lift the image drum, complete with its toner cartridge, up and out of the printer.

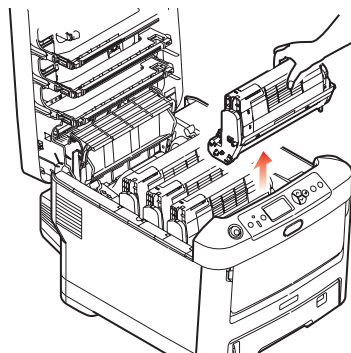

4. Put the assembly down gently onto a piece of paper to prevent toner from marking your furniture and to avoid damaging the green drum surface.

CAUTION!

The green image drum surface at the base of the ID unit is very delicate and light sensitive. Do not touch it and do not expose it to normal room light for more than 5 minutes. If the drum unit needs to be out of the printer for longer than this, please wrap the cartridge inside a black plastic bag to keep it away from light. Never expose the drum to direct sunlight or very bright room lighting.

5. With the coloured toner release lever (1) to the right, pull the lever towards you. This will release the bond between the toner cartridge and the image drum unit.

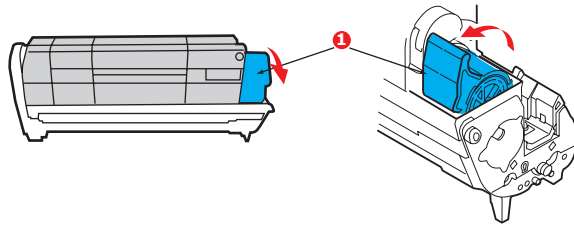

6. Lift the right-hand end of the toner cartridge (1) and then draw the cartridge to the right to release the left-hand end as shown (2), and withdraw the toner cartridge out of the image drum cartridge. Place the cartridge on a piece of paper to avoid marking your furniture.

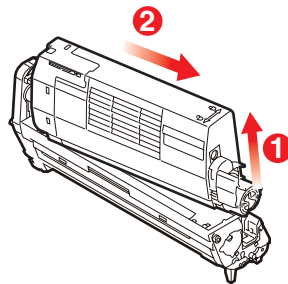

7. Take the new image drum cartridge out of its packaging and place it on the piece of paper where the old cartridge was placed. Keep it the same way round as the old unit. Pack the old cartridge inside the packaging material for disposal.

NOTE:

Follow instructions that come with the new image drum for additional information such as the removal of packaging material etc.

8. Place the toner cartridge onto the new image drum cartridge as shown. Push the left end in first, and then lower the right end in. (It is not necessary to fit a new toner cartridge at this time unless the remaining toner level is very low.)

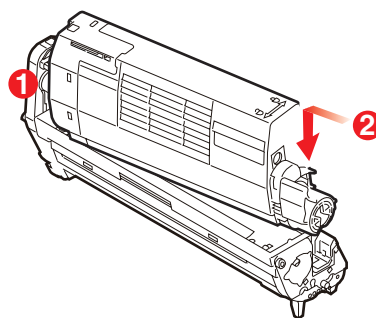

- 9.** Push the coloured release lever away from you to lock the toner cartridge onto the new image drum unit and release toner into it.

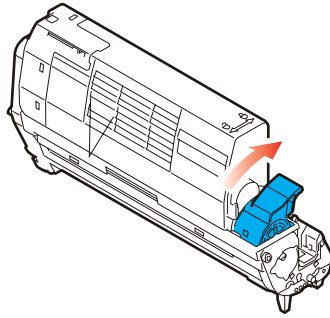

- 10.** Holding the complete assembly by its top centre, lower it into place in the printer, locating the pegs at each end into their slots in the sides of the printer cavity.

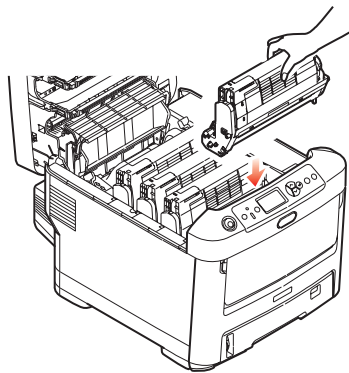

- 11.** Finally, close the top cover and press down firmly at both sides so that the cover latches closed.

NOTE:

If you need to return or transport your printer for any reason, please make sure you remove the image drum unit beforehand and place in the bag provided. This is to avoid toner spillage.

REPLACING THE TRANSFER BELT UNIT

The belt unit is located under the four image drums. This unit requires replacement approximately every 60,000 pages.

Switch off the printer and allow the fuser to cool for about 10 minutes before opening the cover.

1. Press the cover release and open the printer's top cover fully.

WARNING!

If the printer has been powered on, the fuser will be hot. This area is clearly labelled. Do not touch.

2. Note the positions of the four toner cartridges (a) and image drums (b). It is essential that they go back in the same order.

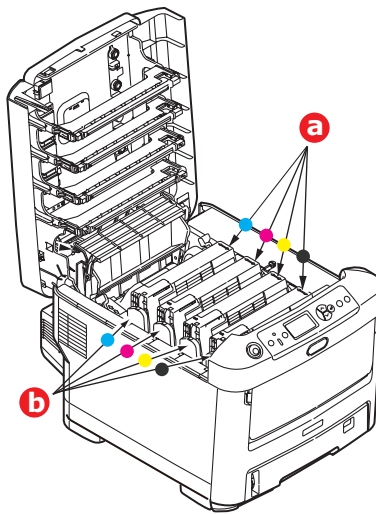

3. Lift each of the image drum units out of the printer and place them in a safe place away from direct sources of heat and light.

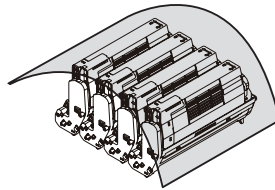

CAUTION!

The green image drum surface at the base of each cartridge is very delicate and light sensitive. Do not touch it and do not expose it to normal room light for more than 5 minutes. If the drum unit needs to be out of the printer for longer than this, please wrap the cartridge inside a black plastic bag to keep it away from light. Never expose the drum to direct sunlight or very bright room lighting.

4. Locate the two fasteners (a) at each side of the belt and the lifting bar (b) at the front end.

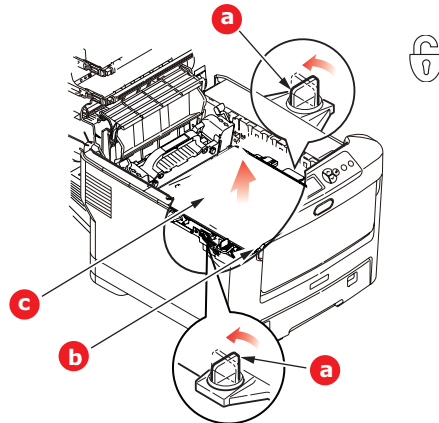

5. Turn the two fasteners 90° to the left. This will release the belt from the printer chassis.
6. Pull the lifting bar (b) upwards so that the belt tilts up towards the front, and withdraw the belt unit (c) from the printer.
7. Lower the new belt unit into place, with the lifting bar at the front and the drive gear towards the rear of the printer. Locate the drive gear into the gear inside the printer by the rear left corner of the unit, and lower the belt unit flat inside the printer.

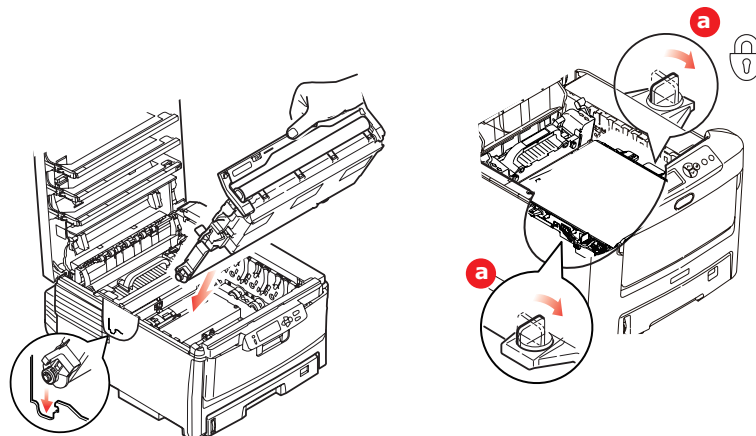

8. Turn the two fasteners (a) 90° to the right until they lock. This will secure the belt unit in place.
9. Replace the four image drums, complete with their toner cartridges, into the printer in the same sequence as they came out: cyan (nearest the rear), magenta, yellow and black (nearest the front).
10. Finally, close the top cover and press down firmly at both sides so that the cover latches closed.

FUSER REPLACEMENT

The fuser is located inside the printer just behind the four image drum units.

WARNING

If the printer has recently been powered on, some fuser components will be very hot. Handle the fuser with extreme care, holding it only by its handle, which will only be mildly warm to the touch. A warning label clearly indicates the area. If in doubt, switch the printer off and wait at least 10 minutes for the fuser to cool before opening the printer cover.

1. Press the cover release and open the printer's top cover fully.
2. Identify the fuser handle (a) on the top of the fuser unit.

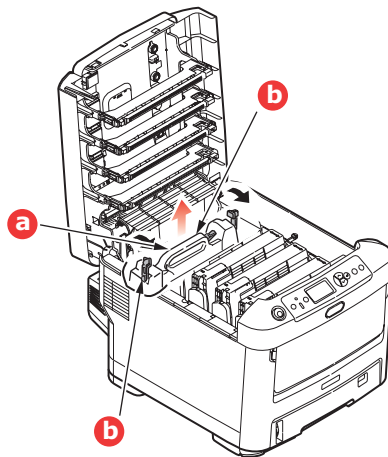

3. Pull the two fuser retaining levers (b) towards the front of the printer so that they are fully upright.
4. Holding the fuser by its handle (a), lift the fuser straight up and out of the printer. If the fuser is still warm, place it on a flat surface which will not be damaged by heat.
5. Remove the new fuser from its packaging and remove the transit material.
6. Holding the new fuser by its handle, make sure that it is the correct way round. The retaining levers (a) should be fully upright, and the two locating lugs (b) should be towards you.

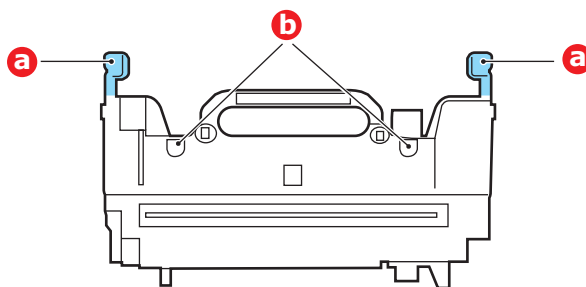

7. Lower the fuser into the printer, locating the two lugs (b) into their slots in the metal partition which separates the fuser area from the image drums.

8. Push the two retaining levers (a) towards the rear of the printer to lock the fuser in place.

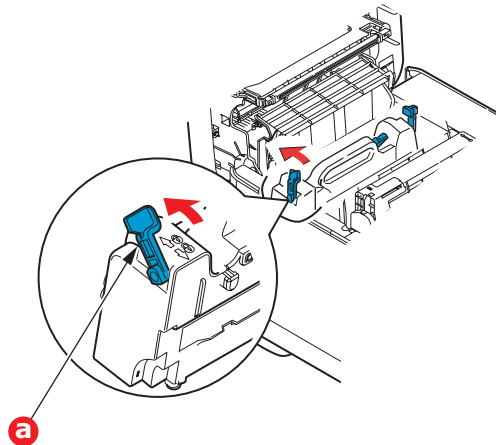

9. Finally, close the top cover and press down firmly at both sides so that the cover latches closed.

CLEANING THE LED HEAD

Clean the LED heads when printing does not come out clearly, has white lines or when text is blurred.

1. Switch off the printer and open the top cover.
2. Gently wipe the LED head surface with a soft tissue

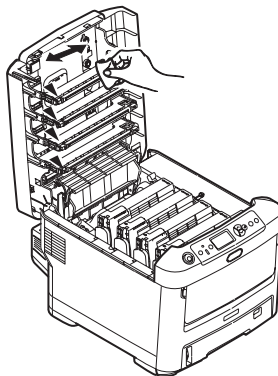

CAUTION!

Do not use methyl alcohol or other solvents on the LED head as damage to the lens surface will occur.

3. Close the top cover.

INSTALLING UPGRADES

This section explains how to install optional equipment into your printer. This includes:

- > duplex (two-sided printing) unit;
[page 53](#):

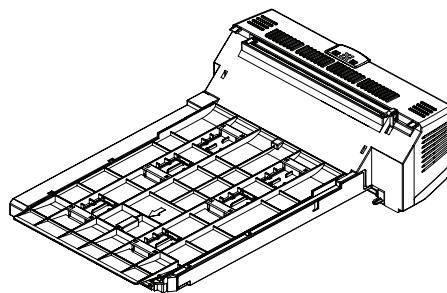

- > additional RAM memory
[page 54](#)

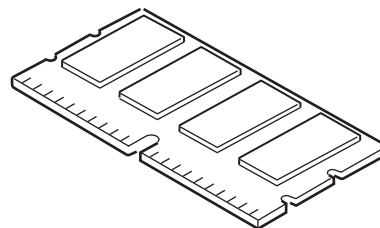

- > hard disk drive.
[page 57](#)

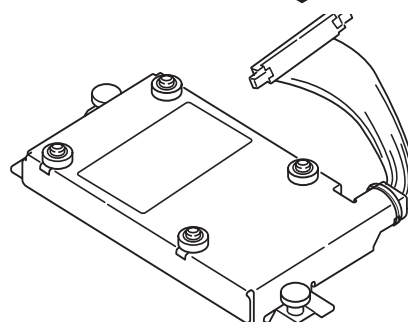

- > additional paper tray(s)
[page 59](#)

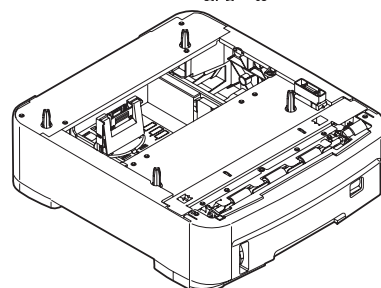

- > cabinet
[page 60](#)

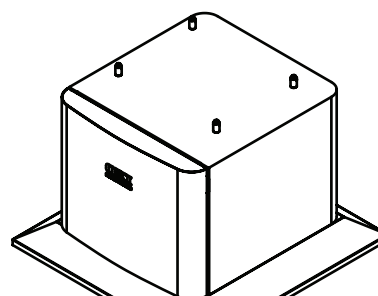

DUPLEX UNIT

The duplex unit adds the function of two-sided printing, using less paper and making large documents easier to handle. It also enables booklet printing, which uses even less paper and makes large documents even easier to handle.

The duplex unit slides straight into the rear of the printer and requires no tools to install.

1. Unpack the new unit and remove any transit material from it.
2. Switch the printer off. It is not necessary to disconnect the AC power cable.
3. Ensure that the unit is the right way up, as shown, and push it into the slot behind the rear panel. The panel will swing inwards as you push the unit into it. Push the unit all the way in until it stops and latches home.

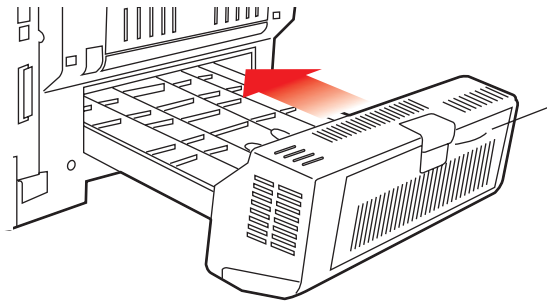

4. Switch the printer on and wait for it to warm up (about 1 minute).
5. Print a menu map as follows:
 - (a) Press the **Enter** button.
 - (b) Press the **Menu down** button, then the **Enter** button to select the Print Information menu.
 - (c) Select **Configuration** with the **Enter** button.
 - (d) Press the **Enter** button once more to execute the Configuration menu.
 - (e) When the Configuration map is printed, press **Online** to exit the menu system.
6. Examine the first page of the menu map.
7. Near the top of the page, between the two horizontal lines, you will see the current printer configuration. This list should indicate that the duplex unit is now installed.

All that remains is to adjust the Windows printer driver to make full use of the new features (["Adjusting Windows printer drivers" on page 60](#)).

MEMORY UPGRADE

The basic printer model comes equipped with 256MB of main memory. This can be upgraded with an additional memory board of 256MB or 512MB, giving a maximum total memory capacity of 768MB.

Installation takes a few minutes, and requires a medium size cross-head (philips type) screwdriver.

1. Switch the printer off and disconnect the AC power cable.

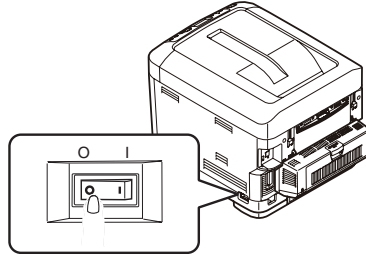

2. Press the cover release and open the printer's top cover fully.

WARNING!

If the printer has been powered on recently, the fuser will be hot. This area is clearly labelled. Do not touch.

3. Pull down the MP Tray using the depressions (b). Lift the front cover release lever and lower the front cover.

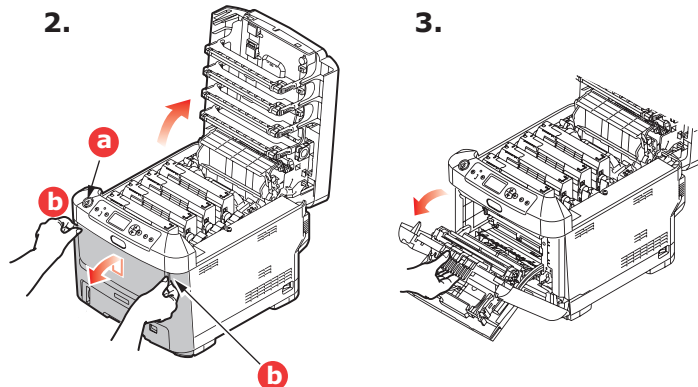

4. Remove the screw (a) securing the right-hand side cover.

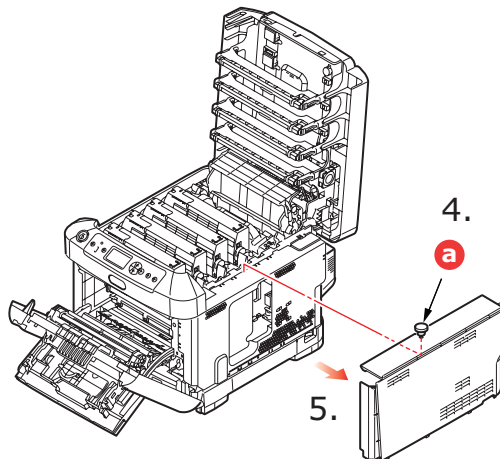

5. Lift the edge of the side cover slightly and pull the cover away from the printer at the top. Lift the cover slightly to detach it from the printer. Place it safely to one side.
6. Carefully remove the new memory board from its wrapping. Try to handle the board only by its short edges, avoiding contact with any metal parts as far as possible. In particular, avoid touching the edge connector.
7. Notice that the memory board has a small cutout in the edge connector, which is closer to one end than the other.

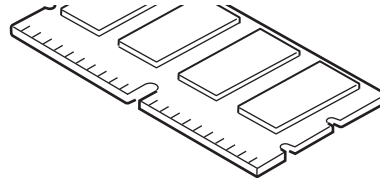

8. Identify the RAM expansion slot in the printer.
9. If the RAM expansion slot already contains a memory upgrade board, that board will have to be removed before you can install the new one. To remove it, proceed as follows, otherwise skip to step 10.
 - (a) Grip the board firmly by its short edges and pull it out of the slot.
 - (b) Place the removed memory board in the antistatic bag which originally contained the new memory board.
10. Hold the new memory board by its short edges, so that the edge connector faces in towards the RAM expansion slot, and the small cutout is closer to the rear of the printer.

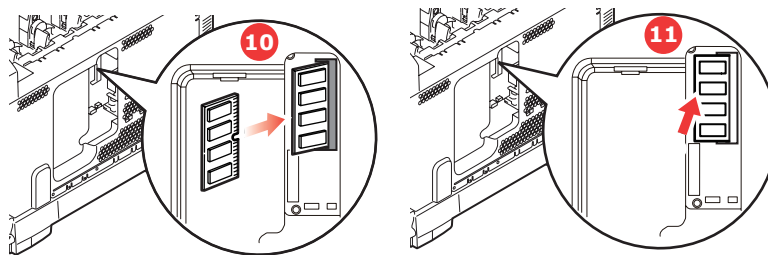

11. Gently push the board into the RAM expansion slot until it latches in and will not go any further.
12. Locate the three retaining clips at the bottom of the side cover into their rectangular holes near the bottom of the printer.

- 13.** Close the top of the side cover up to the printer and refit the securing screw removed in step 4.

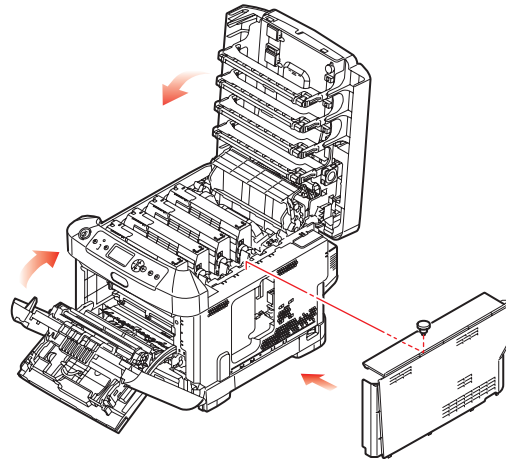

- 14.** Close the front cover, and close the top cover, pressing down firmly at each side to latch it closed.
- 15.** Reconnect the AC power cable and switch the printer on.
- 16.** When the printer is ready, print a menu map as follows:
- (a) Press the **Enter** button.
 - (b) Press the **Menu down** button then the **Enter** button to select the Print Information menu.
 - (c) Select **Configuration** with the **Enter** button.
 - (d) Press the **Enter** button once more to execute the Configuration menu.
 - (e) When the Configuration map is printed, press **On Line** to exit the menu system.
- 17.** Examine the first page of the menu map.

Near the top of the page, between the two horizontal lines, you will see the current printer configuration. This list contains the figure for total memory size.

This should indicate the total memory now installed.

HARD DISK DRIVE

The optional internal hard disk drive (HDD) enables collating of printed pages and can be used to store overlays and macros, fonts, and secure or proof documents waiting to be printed.

Installation takes a few minutes, and requires a medium size cross-head (philips type) screwdriver.

1. Switch the printer off and disconnect the AC power cable.

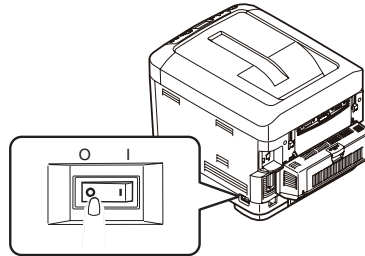

2. Press the cover release and open the printer's top cover fully.

WARNING!

If the printer has been powered on recently, the fuser will be hot. This area is clearly labelled. Do not touch.

3. Pull down the MP Tray using the depressions (b). Lift the front cover release lever and lower the front cover.

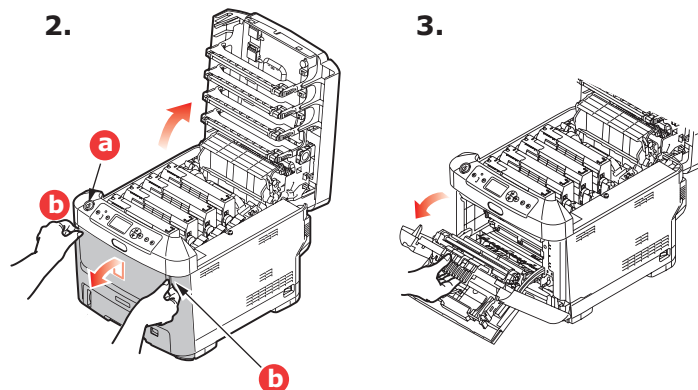

4. Remove the screw (a) securing the right-hand side cover. Lift the edge of the side cover slightly and pull the cover away from the printer at the top. Lift the cover slightly to detach it from the printer. Place it safely to one side.

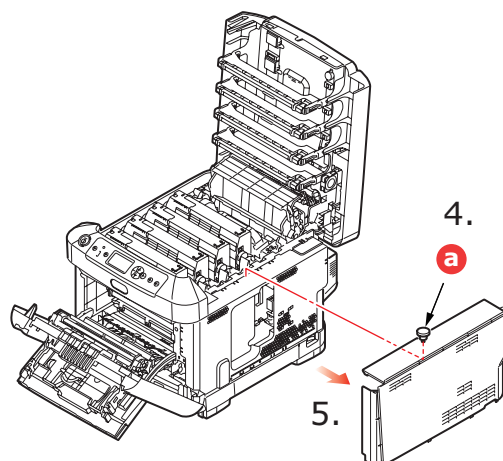

5. Plug the end of the connecting cable (a) into the disk unit connector (b) in the printer.

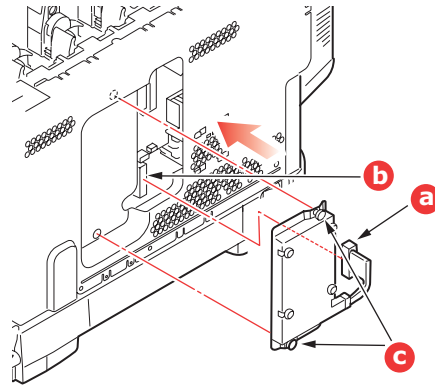

6. Tighten the two thumbscrews (c).
7. Close the top of the side cover up to the printer and refit the securing screw removed in step 4.

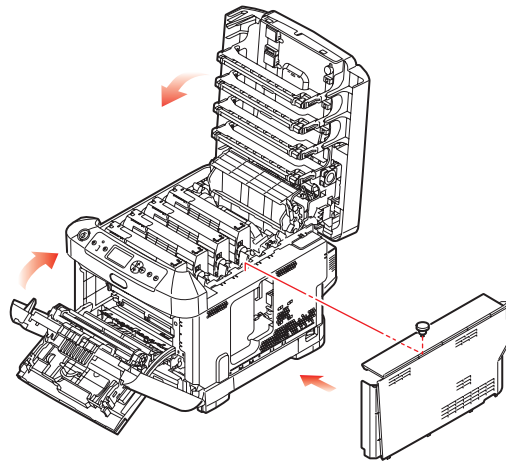

8. Close the front cover and the top cover, pressing down firmly at each side to latch it closed.
9. Reconnect the AC power cable and switch the printer on.
10. When the printer is ready, print a menu map as follows:
 - (a) Press the **Enter** button.
 - (b) Press the **Menu down** button then the **Enter** button to select the Print Information menu.
 - (c) Select **Configuration** with the **Enter** button.
 - (d) Press the **Enter** button once more to execute the Configuration menu.
 - (e) When the Configuration map is printed, press **On Line** to exit the menu system.
11. Examine the first page of the menu map.

Near the top of the page, between the two horizontal lines, you will see the current printer configuration. This should now indicate that the hard disk unit is installed.

ADDITIONAL PAPER TRAY(S)

1. Switch the printer off and disconnect the AC power cable.
2. Place additional paper tray(s) on desired location.

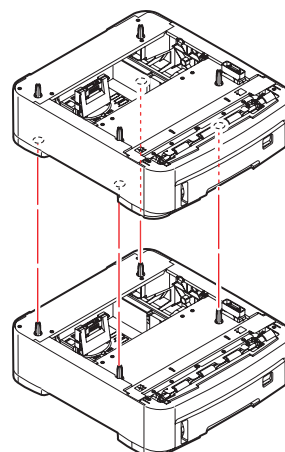

3. Observing safety rules for lifting and, using locating guides, place printer on top of the additional paper tray(s).

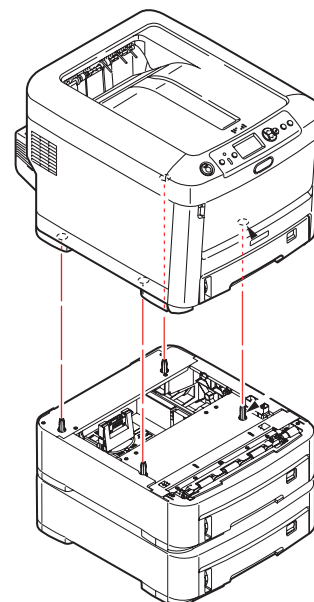

4. Re-connect the AC power cable and switch the printer ON.

ADJUSTING WINDOWS PRINTER DRIVERS

Once your new upgrade has been installed, you may need to update the Windows printer driver so that the additional features are available to your Windows applications.

Remember that if your printer is shared between users on different computers, the driver must be adjusted on each user's machine.

The illustrations shown here are for Windows XP. Other Windows versions may appear slightly different, but the principles are the same.

If you have installed a memory upgrade it is not necessary to change the printer driver, and you can ignore this section.

If you have installed a duplex unit or hard disk, proceed as follows:

1. Open the Printers window (called "Printers and Faxes" in Windows XP) via the **Start** Menu or from the Windows Control Panel.
2. Right-click the printer icon for this printer, and choose **Properties** from the pop-up menu.
3. On the **Device Options** tab, check the box for the upgrade you have just installed.
4. Click **OK** to close the properties window, and then close the Printers window.

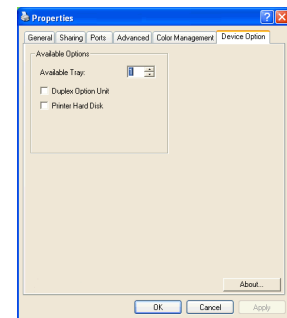

STORAGE CABINET

Instructions for installing the Storage Cabinet are supplied with the Cabinet.

CLEARING PAPER JAMS

Provided that you follow the recommendations in this guide on the use of print media, and you keep the media in good condition prior to use, your printer should give years of reliable service. However, paper jams occasionally do occur, and this section explains how to clear them quickly and simply.

Jams can occur due to paper misfeeding from a paper tray or at any point on the paper path through the printer. When a jam occurs, the printer immediately stops, and the Alert LED on the Status Panel (together with the Status Monitor) informs you of the event. If printing multiple pages (or copies), do not assume that, having cleared an obvious sheet, others will not also be stopped somewhere along the path. These must also be removed in order to clear the jam fully and restore normal operation.

MAJOR PRINTER COMPONENTS AND PAPER PATH

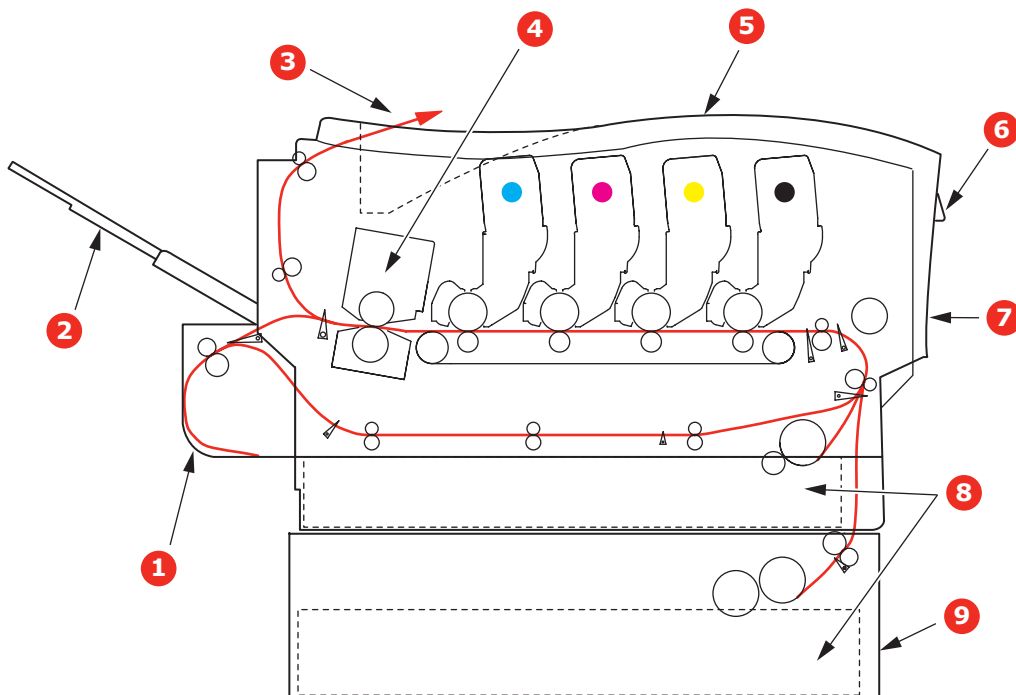

- | | |
|------------------------------------|--|
| 1. Duplex unit (if fitted). | 6. Operator panel. |
| 2. Face-up stacker. | 7. Front cover. |
| 3. Paper exit. | 8. Paper tray. |
| 4. Fuser unit | 9. Additional paper tray (if fitted). |
| 5. Top cover. | |

PAPER SENSOR ERROR CODES

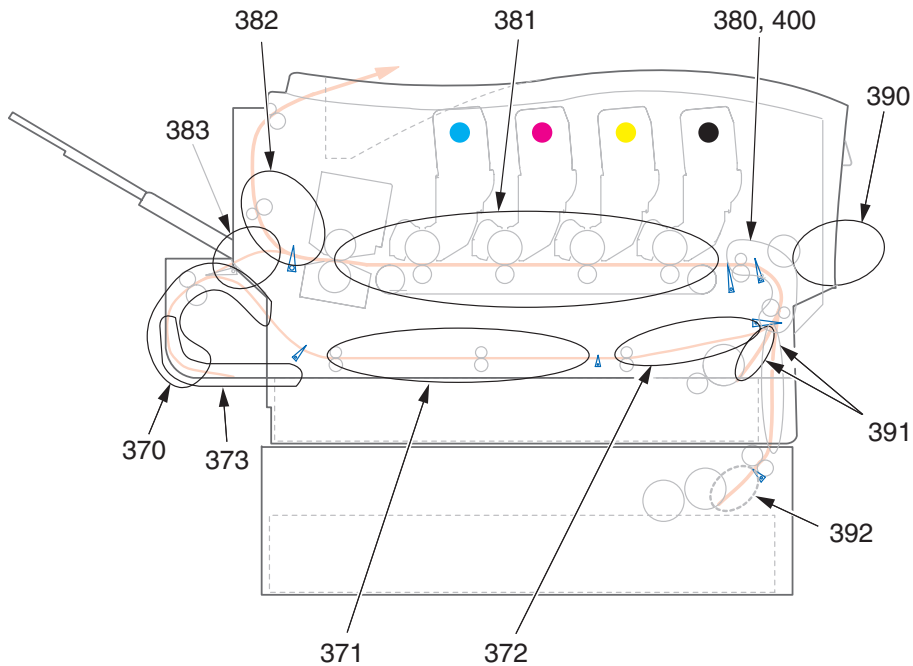

CODE #	LOCATION	CODE #	LOCATION
370	Duplex unit *	382	Paper exit
371	Duplex unit *	383	Duplex unit *
372	Duplex unit *	390	MP Tray
373	Duplex unit *	391	Paper Tray
380	Paper feed	392	2 nd Paper tray *
381	Paper path	400	Paper size

* (if fitted).

1. If a sheet is well advanced out of the top of the printer, simply grip it and pull gently to draw it fully out. If it does not remove easily, do not use excessive force. It can be removed from the rear later.
2. Press the cover release and open the printer's top cover fully.

WARNING!

If the printer has been powered on, the fuser will be hot. This area is clearly labelled. Do not touch.

3. Note the positions of the four toner cartridges (a) and image drums (b). It is essential that they go back in the same order.

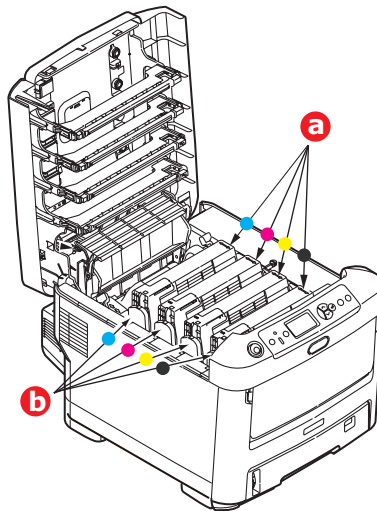

It will be necessary to remove the four image drums to gain access to the paper path.

4. Holding it by its top centre, lift the cyan image drum, complete with its toner cartridge, up and out of the printer.

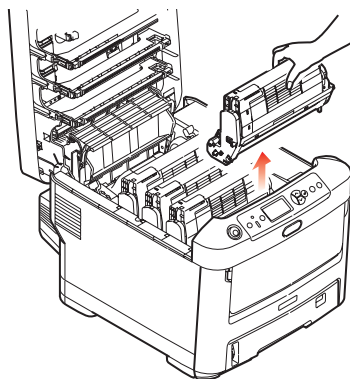

5. Put the assembly down gently onto a piece of paper to prevent toner from marking your furniture and to avoid damaging the green drum surface, and cover.

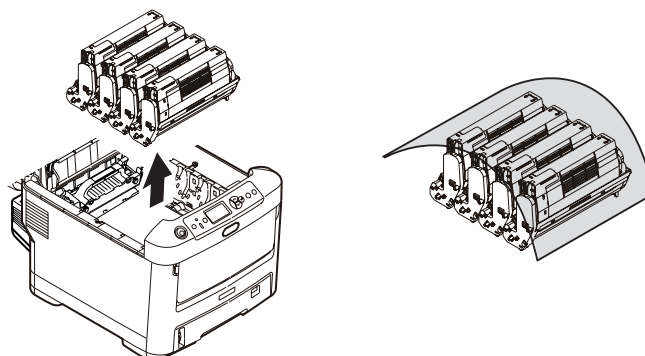

CAUTION!

The green image drum surface at the base of the Image Drum is very delicate and light sensitive. Do not touch it and do not expose it to normal room light for more than 5 minutes.

6. Repeat this removal procedure for each of the remaining image drum units.

7. Look into the printer to check whether any sheets of paper are visible on any part of the belt unit.

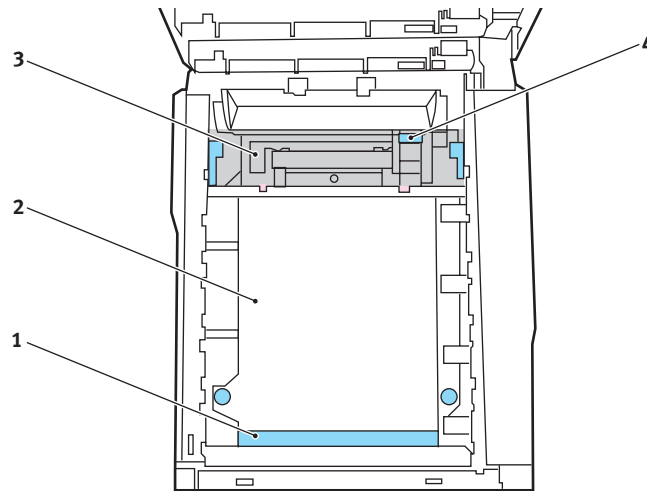

CAUTION!

Do not use any sharp or abrasive objects to separate sheets from the belt. This may damage the belt surface.

- (a) To remove a sheet with its leading edge at the front of the belt (1), carefully lift the sheet from the belt and pull it forwards into the internal drum cavity and withdraw the sheet.

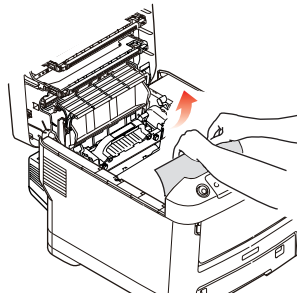

- (b) To remove a sheet from the central area of the belt (2), carefully separate the sheet from the belt surface and withdraw the sheet.

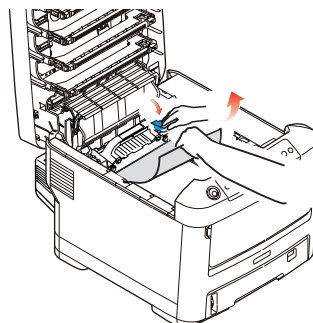

- (c) To remove a sheet just entering the fuser (3), separate the trailing edge of the sheet from the belt, push the fuser pressure release lever (4) towards the front and down to release the fuser's grip on the sheet, and withdraw the sheet through the drum cavity area. Then allow the pressure release lever to rise again.

NOTE:

If the sheet is well advanced into the fuser (only a short length is still visible), do not attempt to pull it back. Follow the next steps.

- (d) To remove a sheet in the fuser; push the two retaining levers (a) towards the rear of the printer to release the fuser. Withdraw the fuser unit using the handle (b).

Press release lever (c) and pull the trapped paper from the fuser.

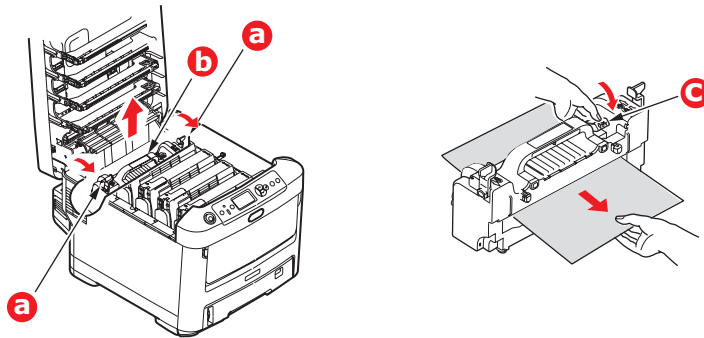

- (e) Replace fuser unit into the machine and move locking levers (a) toward the rear of the machine.

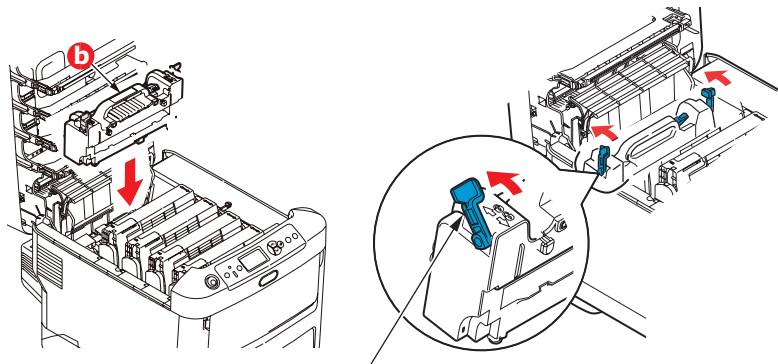

- 8.** Starting with the cyan image drum unit nearest the fuser, replace the four image drums into the drum cavity, making sure to locate them in the correct order.

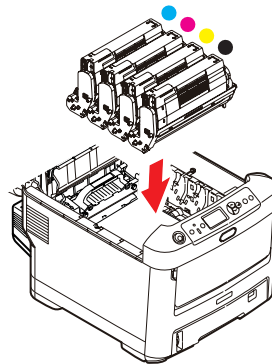

Holding the complete assembly by its top centre, lower it into place in the printer, locating the pegs at each end into their slots in the sides of the printer cavity.

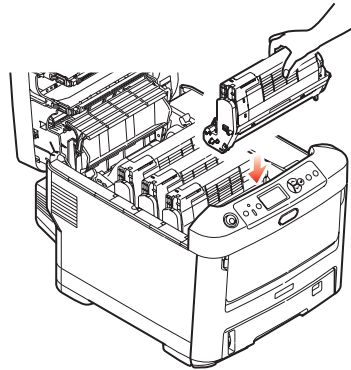

9. Lower the top cover but do not press down to latch it closed yet. This will protect the drums from excessive exposure to room lighting while you check the remaining areas for jammed sheets.
10. Open the rear exit tray (a) and check for a sheet of paper in the rear path area (b).

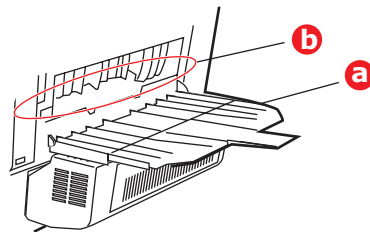

- > Pull out any sheets found in this area.
- > If the sheet is low down in this area and difficult to remove, it is probably still gripped by the fuser. In this case raise the top cover, reach around and press down on the fuser pressure release lever (a).

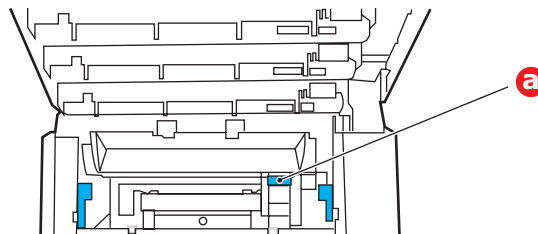

11. If you are not using the rear exit tray, close it once any paper has been removed from this area.
12. If a duplex unit is fitted, lift lever (a) and lower the duplex unit cover and pull out any sheets found in this area. Close the duplex unit cover

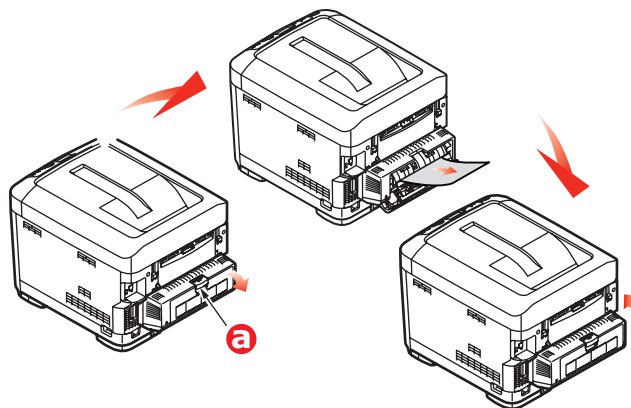

- 13.** Pull down the MP Tray using the depressions. Lift the front cover release lever and lower the front cover.

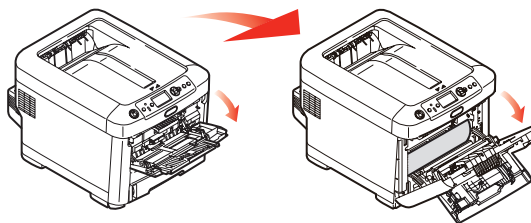

- 14.** Check inside the cover for sheets in this area and remove any that you find, then close the cover.

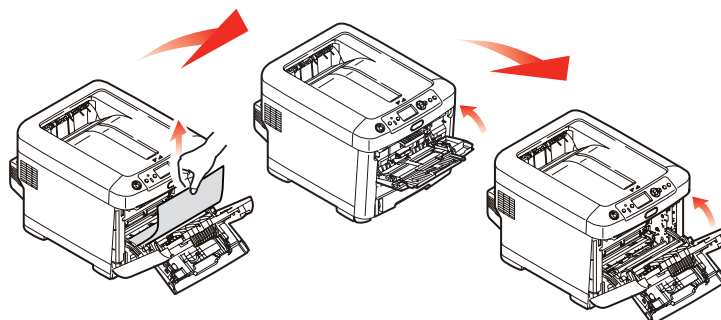

- 15.** Pull out the paper tray and ensure that all paper is stacked properly, is undamaged, and that the paper guides are properly positioned against the edges of the paper stack. When satisfied, replace the tray.

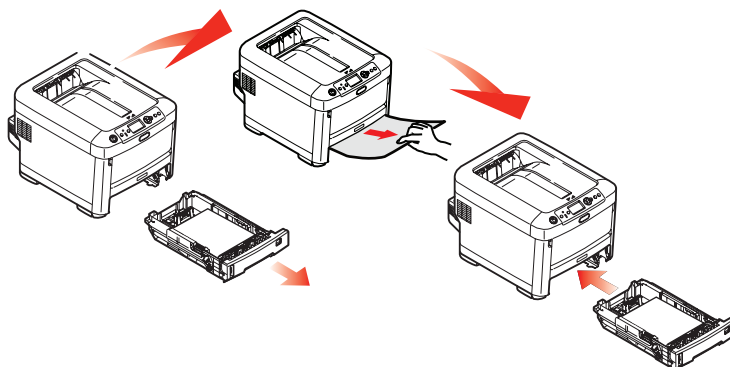

- 16.** Finally, close the top cover and press down firmly so that the cover latches closed. When the jam has been cleared, if Jam Recovery is set to ON in the System Configuration Menu, the printer will attempt to reprint any pages lost due to paper jams.

SPECIFICATIONS

C710 - N31191B

ITEM	SPECIFICATION
Dimensions	435 x 536 x 370mm (W x D x H) without Duplex unit
Weight	27.6Kg approx. (without Duplex unit)
Print method	LED exposed light source electronic photographic method
Print speeds	30 pages per minute colour / 32 pages per minute monochrome
Resolution	600 x 600, 600 x 1200dpi x 1bit or 600 x 600dpi x 2bit
Emulations	PostScript 3 PCL 5c, HP-GL, PCL XL, PCL 6e Epson FX IBM Pro Printer III XL
Auto Features	Auto registration Auto density adjustment Auto consumable counter reset
Memory	256MB standard, upgradable to 512MB or 768MB
Operating platform	Windows 2000/XP/XP Pro x64 bit Edition*/NT4.0 /Server 2003/Server 2003 x64 bit Edition*, Vista 32 & 64 bit. * x86-64 processors only. Itanium is not supported. Mac OS X (10.2.8 - 10.5 on PPC; 10.4.4 - 10.5 on Intel).
Paper capacity at 80g/m ²	530 sheets in main tray 530 sheets in optional 2nd tray 100 sheets in multi purpose tray (or 50 transparencies or 10 envelopes)
Paper weight	64 ~ 176g/m ² in main tray 64 ~ 203g/m ² in 2nd or 3rd tray 64 ~ 220g/m ² in multi purpose tray
Paper output	350 sheets in face down (top) stacker @ 80g/m ² 100 sheets in face up (rear) stacker @ 80g/m ²
Paper feed ^a	Paper tray, manual feed, optional additional paper tray(s)
Media size - any tray	A4, A5, B5, Legal 13/13.5/14 inch, Letter, Executive.
Media size - MP tray	A4, A5, A6, B5, Legal 13/13.5/14 inch, letter, executive, custom (up to 1220mm length), com-9 envelope, com-10 envelope, monarch envelope, DL envelope, C5 envelope, index card (76.2 x 127mm), Photo 101.6 x 127/177.8), Banner (297 x 1220mm)
Media type	Plain, Letterhead, Transparency, Bond, card stock, Rough, Labels
Exit capacity (depending on paper weight)	Face up stacker: 100 sheets approx. Face down stacker: 350 sheets approx.
Print accuracy	Start: ±2 mm Paper skew: ±1 mm/100 mm Image expansion/compression: ±1 mm/100 mm
HDD	Capacity - 40GB

ITEM	SPECIFICATION
Interfaces Universal Serial Bus (USB)	USB specification Version 2.0 Connection: USB type B Cable: USB specification version 2.0 (shielded) Transmission mode: High speed (480Mbps + 0.25% maximum)
Network Parallel Interface	10 Base T, 100 Base T IEEE 1284
Printer life	600,000 pages or 5 years
Duty cycle	80,000 pages per month max., 6,000 pages per month average
Toner life	Starter: CMYK: 4,000 pages at 5% coverage Replacement: CMYK: 10,000 pages at 5% coverage
Image drum life	K Approximately 20,000 A4 pages @ 3 pages per job. CMY Approximately 15,000 A4 pages @ 3 pages per job.
Belt life	60,000 A4 pages at 3 pages per job
Fuser life	60,000 A4 pages
Power supply	220 to 240VAC @ 50/60 Hz ± 1 Hz
Power consumption	Operating: 1200 max.; 530 W av. (25°C) Stand-by: 100 max.; 150 W av. (25°C) Power saving: 17 W max.
Operating environment	Operating 10 to 32 °C/20 to 80% RH (optimum 25 °C wet, 2 °C dry) Off: 0 to 43 °C/10 to 90% RH (optimum 26.8 °C wet, 2 °C dry)
Print environment	30 to 73% RH @ 10 °C; 30 to 54% RH @ 32 °C 10 to 32 °C @ 30% RH; 10 to 27 °C @ 80% RH Colour 17 to 27 °C @ 50 to 0% RH
Noise (Sound pressure level)	Colour Mono Operating: 55dB(A) 55.6dB(A) Standby: 37dB(A)

a. Exit method is limited by paper size, media weight and paper feed.

Specifications subject to change without notice. All trademarks acknowledged.

INDEX

B

- Belt
 - how to replace 48
 - life expectancy..... 40

C

- Cleaning the LED head..... 51

D

- Duplex
 - how to install 53
 - paper size and weight limits 10

E

- Envelopes
 - loading 14

F

- Fuser
 - how to replace 50
 - life expectancy..... 40

H

- Hard disk drive
 - how to install 57

I

- Image drum
 - how to replace 45
 - life expectancy..... 40

L

- Labels
 - recommended types 9

M

- Maintenance menu 37
- Major printer components and paper path 61
- Menu functions..... 16
- Menus
 - factory default settings..... 17
 - how to use 16
 - USB menu..... 37
- Multi purpose tray
 - how to use 14
 - paper metrics 10

O

- Operator Panel 16

P

- Paper
 - jam clearing..... 61
 - jam, error codes 62
 - loading cassette trays..... 11
 - loading letterhead..... 12
 - recommended types 9
 - supported sheet sizes..... 9
- Print order
 - face down stacker..... 13
 - face up stacker 13
- Printer overview 7

S

- Switching off correctly 24

T

- Toner
 - how to replace 41
 - life expectancy 40
- Transparencies
 - recommended types..... 9

U

- Upgrades
 - memory 54

OKI CONTACT DETAILS

Ok Systems (UK) Limited

550 Dundee Road
Slough Trading Estate
Slough, SL1 4LE

Tel: 44 (0) 1753 819819
Fax: 44 (0) 1753 819899
<http://www.okiprintingsolutions.co.uk>

Ok Systems Ireland Limited

The Square Industrial Complex
Tallaght, Dublin 24, Ireland

Tel: +353 1 4049590
Fax: +353 1 4049591
<http://www.oki.ie>

OKI Systems - Northern Ireland

40 Sydenham Park
Belfast, BT4 1PW

Tel: +44 (0)28 90 20 1110
<http://www.oki.ie>

Technical Support for all Ireland:

Tel: +353 1 4049570
Fax: +353 1 4049555
E-mail: tech.support@oki.ie

Ok Data Corporation

4-11-22 Shibaura, Minato-ku, Tokyo
108-8551, Japan

Tel: (81) 3 5445 6158
Fax: (81) 3 5445 6189
<http://www.okidata.co.jp>

Ok Data (Singapore) Pte. Ltd.

78 Shenton Way, #09-01,
Singapore 079120

Tel: (65) 6221 3722
Fax: (65) 6421 1688
<http://www.okidata.com.sg>

Ok Systems (Thailand) Ltd.

1168/81-82 Lumpini Tower,
27th Floor, Rama IV Rd.,
Tungmahamek, Sathorn,
Bangkok 10120

Tel: +662 6799235
Fax: +662 6799245
<http://www.okisysthai.com/oki>

Ok Hong Kong Limited

Unit 607, 6/F, Island Place Tower,
510 Kings Road, North Point,
Hong Kong

Tel: (852) 3543 9200
Fax: (852) 3549 6040

The IPL Group

146 O'Riordan Street
Mascot NSW 2020 Australia

Tel : (61) 2 9667 7000
Fax : (61) 2 9667 7094
<http://www.oki.com.au>

Comworth Systems Ltd.

10 Constellation Drive, Mairangi Bay,
Auckland, New Zealand

Tel: (64) 9 477 0500
Fax: (64) 9 477 0549
<http://www.comworth.co.nz>

Ok Data(S) P Ltd. Malaysia Rep Office

Suite 21.03, 21st Floor Menara IGB,
Mid Valley City,
Lingkaran Syed Pura 59200,
Kuala Lumpur, Malaysia

Tel: (60) 3 2287 1177
Fax: (60) 3 2287 1166

OKI EUROPE LIMITED

Blays House

Wick Road

Egham

Surrey TW20 0HJ

United Kingdom

Tel: +44 (0) 208 219 2190

Fax: +44 (0) 208 219 2199

WWW.OKIPRINTINGSOLUTIONS.COM

