

# OLYMPUS®

---

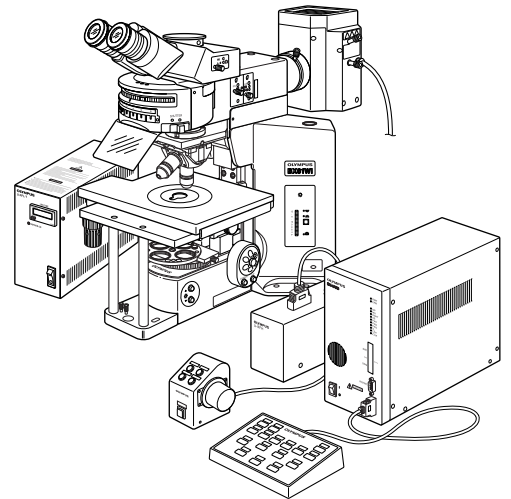

## INSTRUCTIONS

---

# BX61WI

## FIXED-STAGE MOTORIZED UPRIGHT MICROSCOPE

This instruction manual is for the Olympus Fixed-Stage Motorized Upright Microscope Model BX61WI. To ensure the safety, obtain optimum performance and to familiarize yourself fully with the use of this microscope, we recommend that you study this manual thoroughly before operating the microscope. Retain this instruction manual in an easily accessible place near the work desk for future reference.



A X 6 1 1 8



This device complies with the requirements of directive 98/79/EC concerning in vitro diagnostic medical devices. CE marking means the conformity to the directive.

**NOTE:** This equipment has been tested and found to comply with the limits for a Class A digital device, pursuant to Part 15 of the FCC Rules. These limits are designed to provide reasonable protection against harmful interference when the equipment is operated in a commercial environment. This equipment generates, uses, and can radiate radio frequency energy and, if not installed and used in accordance with the instruction manual, may cause harmful interference to radio communications. Operation of this equipment in a residential area is likely to cause harmful interference in which case the user will be required to correct the interference at his own expense.

**FCC WARNING:** Changes or modifications not expressly approved by the party responsible for compliance could void the user's authority to operate the equipment.

# CONTENTS

Correct assembly and adjustments are critical for the microscope to exhibit its full performance. If you are going to assemble the microscope yourself, please read Chapter 9, "ASSEMBLY" (pages 42 to 49) carefully. For the modules provided with instruction manuals, also read the assembly procedures in their instruction manuals.

**IMPORTANT – Be sure to read this section for safe use of the equipment. – 1-3**

<b>1</b>	<b>MODULE NOMENCLATURE</b>	<b>4</b>
<b>2</b>	<b>CONTROLS</b>	<b>5-11</b>
<b>3</b>	<b>TRANSMITTED LIGHT BRIGHTFIELD OBSERVATION PROCEDURE</b>	<b>12, 13</b>
<b>4</b>	<b>USING THE CONTROLS</b>	<b>14-23</b>
4-1	Microscope Frame .....	14, 15
1	Voltage Indication	
2	Transmitted/Reflected Light Switch	
3	Light Preset Switch	
4	Using the Filter Turret	
4-2	Focusing Block.....	15, 16
1	Replacing the Focus Adjustment Knob	
2	F/C Button	
3	Objective Up/Down Buttons	
4	Objective Escape/Return Button	
5	Using the Frost Filter Insertion/Removal Lever	
4-3	Stage (IX-SVL2) .....	17, 18
1	Placing the Specimen	
2	Moving the Specimen	
3	Setting the Grounding	
4	Adjusting the X-Axis/Y-Axis Knob Rotation Tension	
5	Using the Light Shielding Sheet	
6	Lowering the Stage Height	
4-4	Revolving Nosepiece .....	18
1	Switching the Objectives	
4-5	Observation Tube .....	19, 20
1	Adjusting the Interpupillary Distance	
2	Adjusting the Diopter	
3	Using the Eye Shades	
4	Using Eyepiece Micrometer Disks	
5	Selecting the Light Path of Trinocular Tube	
4-6	Condenser .....	21 ,22
1	Centering the Condenser	
2	Oblique Illumination (WI-OB CD)	
4-7	Water Immersion Objectives .....	23
1	Using Water Immersion Objectives (Water Immersion Cap)	

<b>5</b>	<b>OTHER OBSERVATION METHODS</b>	<b>24-35</b>
5-1	Differential Interference Contrast Observation .....	24-28
	<b>1</b> Attaching the Analyzer <b>2</b> Attaching the Polarizer	
	<b>3</b> Attaching the DIC Prisms (for Revolving Nosepiece)	
	<b>4</b> Attaching the DIC Prisms (for Condenser)	
	<b>5</b> Adjusting the Polarizer Position (except the U-UCD8)	
	<b>6</b> Observation Method	
5-2	Reflected Light Fluorescence Observation.....	29
5-3	Infrared Light (IR)/Differential Interference Contrast (DIC) Observation .....	29-32
	<b>1</b> Introduction <b>2</b> Attaching the IR Modules	
	<b>3</b> DIC Observation Using IR	
5-4	Macro Reflected Light Fluorescence Observation .....	33-35
	<b>1</b> Introduction <b>2</b> Attaching the Modules	
	<b>3</b> Filter Characteristics of Fluorescence Mirror Units	
	<b>4</b> Fabricating Optional Mirror Units	
<b>6</b>	<b>TROUBLESHOOTING GUIDE</b>	<b>36-38</b>
<b>7</b>	<b>SPECIFICATIONS</b>	<b>39, 40</b>
<b>8</b>	<b>OPTICAL CHARACTERISTICS</b>	<b>41</b>
<b>9</b>	<b>ASSEMBLY – See this section for the replacement of the light bulb. –</b>	<b>42-49</b>
<b>10</b>	<b>LAMP HOUSING INSPECTION SHEET</b>	<b>50</b>

# IMPORTANT

This microscope employs a UIS2 (UIS) (Universal Infinity System) optical design, and should be used only with modules designed for the BX2 series (which belong to the Olympus BX series). For the applicable modules, please consult Olympus or the latest catalogues. Less than optimum performance may result if inappropriate module combinations are used.

### Configuration of Instruction Manuals

Since this microscope is expandable to a variety of systems, separate instruction manuals are prepared so that the user has to read only the manuals according to the user's own system.

Manual Name	Main Contents
BX61WI	Observation procedures including transmitted light brightfield, DIC and IR observations
BX-UCB/U-HSTR2	Functions of the Control Box (incorporating the power supply) and Hand Switch
BX2 Software for PC (CD-ROM) * BX2-BSW Ver. 03.01 or higher	Methods of PC control of functions * Normal operation is not available unless the specified software is used.
TH4	External halogen lamp power supply
BX-RFAA/BX-URA2/BX-RFA	Reflected light fluorescence observation procedure
U-FWT/FWR/FWO	Motorized filter wheels (The U-FWT cannot be used with this microscope.)
WI-DPMC	Information on the dual-port magnification changer tube
WI-XYM/XYS	Information on the XY mover and bridge stage
WI-SSNP	Information on the swing-slide revolving nosepiece



## SAFETY PRECAUTIONS

- After the equipment has been used in an observation of a specimen that is accompanied with a potential of infection, clean the parts coming in contact with the specimen to prevent infection.
  - Moving this product is accompanied with the risk of dropping the specimen. Be sure to remove the specimen before moving this product.
  - In case the specimen is damaged by erroneous operation, promptly take the infection prevention measures.
  - The product becomes unstable if its height is increased by an accessory mounted on it. In this case, take anti-toppling measures to prevent the specimen from being dropped when the product topples down.
- Culture liquid or water spilt on the stage, condenser or microscope may damage the equipment. Immediately wipe the liquid or water off if it is spilt on them.
- If a foreign object is caught during motorized focusing operation, there will be an error in the focusing block and the motorized focusing operation will be suspended.

### Recovery procedure

- If there is no error in motorized operation, the caught object can be removed by turning the focusing knob.
  - If there is an error in motorized operation, the focusing knob becomes inoperable. Disassemble the relevant modules to remove the caught object. Replace the relevant modules afterward.
  - Turn off the power and then on again. The system will restart unless there is a malfunction in the motor.
- Emergency stop of focus operation is possible by turning the focus adjustment knob (or dial) on the microscope frame or on the U-FH (in either direction), or by pressing the FOCUS control button (  $\Delta$  ,  $\nabla$  , F/C or ESC), after focus operation has been activated (except when data is being downloaded to a PC).

When the BX-UCB control box's main switch is set to "I" (ON), the focus operates automatically (the objective raises once and then returns to the original position) for initialization. (It takes about one minute.)

If the above emergency procedure is performed during this automatic focus operation, the microscope stops operating. Should this happen, set the main switch to "O" (OFF) and then "I" (ON) again.

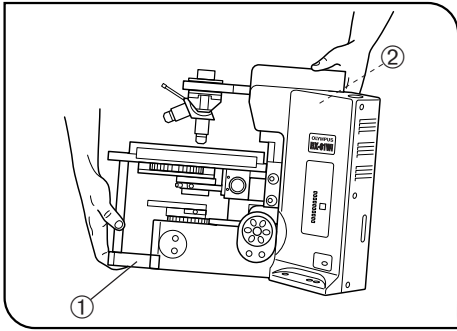

Fig. 1

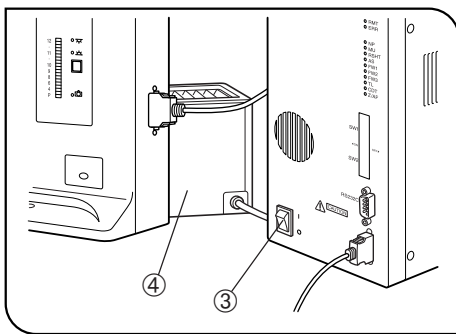

Fig. 2

5. When moving the microscope, disconnect the reflected light illuminator, observation tube and transmitted light lamp housing and carefully carry the microscope by the base (front edge) ① and the grasping part on the rear of the arm ② as shown in Fig. 1. (Weight: approx. 15 kg.)

Also be careful against slipping of hands during carrying.

★ **Damage to the microscope will occur if you grasp it by other parts including the stage, focus adjustment knob, etc.**

6. The surfaces of the lamp housing on the rear of the microscope will become extremely hot during operation. When installing the microscope, make sure to allow ample free space (10 cm or more) around and in particular above the lamp housing.

7. When installing the microscope, route the power cord away from the lamp housing. Should the power cord come in contact with the hot lamp housing, the power cord could melt and cause electric shock.

8. To avoid potential shock hazards and burns when replacing the light bulb, set the main switch ③ to “○” (OFF) then disconnect the power cord from the wall outlet in advance. Whenever you replace the bulb during use or right after use, allow the lamp housing ④ and bulb to cool before touching. (Fig. 2)

Designated Bulbs	12V100WHAL (PHILIPS 7724) 12V50WHAL-L (LIFE JC)
------------------	--

★ **The microscope also incorporate a fuse (this should be replaced by the manufacturer or an Olympus-authorized agent).**

9. Always use the power cord provided by Olympus. If the proper power cord is not used, product safety performance cannot be warranted.

10. Always ensure that the **grounding terminal** of the microscope and that of the wall outlet are properly connected. If the equipment is not grounded, Olympus can no longer warrant the electrical safety performance of the equipment.

11. Never insert metallic objects into the air vents of the microscope frame as this could result in electrical shock, personal injury and equipment damage.

### Safety Symbols

The following symbols are found on the microscope. Study the meaning of the symbols and always use the equipment in the safest possible manner.

Symbol	Explanation
	Indicates that the surface becomes hot, and should not be touched with bare hands.
	Before use, carefully read the instruction manual. Improper use could result in personal injury to the user and/or damage to the equipment.
	Indicates that the main switch is ON.
	Indicates that the main switch is OFF.

### Warnings

Warning engraving is placed at parts where special precaution is required when handling and using the microscope. Always heed the warnings.

Warning engraving position	Lamp housing (U-LH100-3/U-LH100IR) (Warning against high temperature)
----------------------------	--

## 1 Getting Ready

1. A microscope is a precision instrument. Handle it with care and avoid subjecting it to sudden or severe impact.
2. The U-SWTR-3 super-widefield observation tube (FN 26.5) cannot be used with the BX61WI microscope.
3. The BX61WI microscope can be used with an intermediate attachment (such as a BX-RFAA, BX-URA2 or BX-RFA reflected light illuminator, U-ECA or U-CA magnification changer, etc).  
Two intermediate attachments can be used only in the following conditions:
  - The U-CA or U-ECA magnification changer or U-FWO filter wheel can be mounted as the second attachment.
  - When a TV adapter with 1X or higher power is used, 2/3-inch CCD TV observation is possible.
  - The peripheral areas of the field of view may be obscured or cut off in binocular observation using the U-TR30-2, U-ETR3 or U-TR30IR (FN 22) super-widefield observation tube.
4. In IR (infrared) observation, the U-CA or U-ECA magnification changer can be used only when the U-ETR3 or U-TR30IR observation tube is used.
5. In photomicrography with visible light, correct exposure may be impossible if the microscope is set for IR observation. Be sure to engage the provided IR cut filter (light blue) before photomicrography.
6. When the XLUMPlanFLN20XW objective is used, only the U-TV1X, U-TVAC, U-PMTVC2XIR or U-PMTVC4XIR TV adapter can be used.
7. Do not attempt to remove or loosen the click springs and screws. Otherwise, Olympus can no longer warrant the performance of the microscope.  
The clicking force of the revolving nosepiece has been set weak in order to reduce vibrations during objective switching. To reproduce the correct click position, switch the objectives gently by operating the lever.
8. Caution for use of the U-ETR3 upright trinocular tube:  
When the aperture stop of the condenser is reduced using a reflected light fluorescence illuminator and the LUMPlanFI60XW objective, part of the observed field of view may be obscured slightly. This is due to the reduction of the light intensity in the field of view due to the narrow aperture and is not due to a defective optical adjustment of the microscope. This phenomenon does not affect the photomicrography or TV camera light path.

## 2 Maintenance and Storage

1. To clean the lenses and other glass components, simply blow dirty away using a commercially available blower and wipe gently using a piece of cleaning paper (or clean gauze).  
If a lens is stained with fingerprints or oil smudges, wipe it gauze slightly moistened with commercially available absolute alcohol.  
**▲ Since the absolute alcohol is highly flammable, it must be handled carefully.**  
**Be sure to keep it away from open flames or potential sources of electrical sparks — for example, electrical equipment that is being switched on or off, which could cause ignition of a fire.**  
**Also remember to always use it only in a well-ventilated room.**
2. Do not attempt to use organic solvents to clean the microscope components other than the glass components. To clean them, use a lint-free, soft cloth slightly moistened with a diluted neutral detergent.
3. Never attempt to disassemble any part of the microscope.
4. When not using the microscope, make sure to set the main switch to “○” (OFF), confirm that the lamp housing is cool enough and cover the microscope with the provided dust cover.

## 3 Caution

If the microscope is used in a manner not specified by this manual, the safety of the user may be imperiled. In addition, the equipment may also be damaged. Always use the equipment as outlined in this instruction manual.

The following symbols are used to set off text in this instruction manual.

- ▲ : Indicates that failure to follow the instructions in the warning could result in bodily harm to the user and/or damage to equipment (including objects in the vicinity of the equipment).
- ★ : Indicates that failure to follow the instructions could result in damage to equipment.
- ◎ : Indicates commentary (for ease of operation and maintenance).

## 4 Intended use

This instrument has been designed to be used to observe magnified images of specimens in routine and research applications.  
Do not use this instrument for any purpose other than its intended use.

# 1 MODULE NOMENCLATURE

©The modules shown below are only the representative modules. As there are other modules which can be combined with the microscope but are not shown below, please also refer to the latest Olympus catalogues or your dealer.

**CAUTION**

The Z board combined with the BX61WI must always be the U-ZPCB(T2). Also note that the DIP switch setting should be changed when the Z board is used (see page 44).

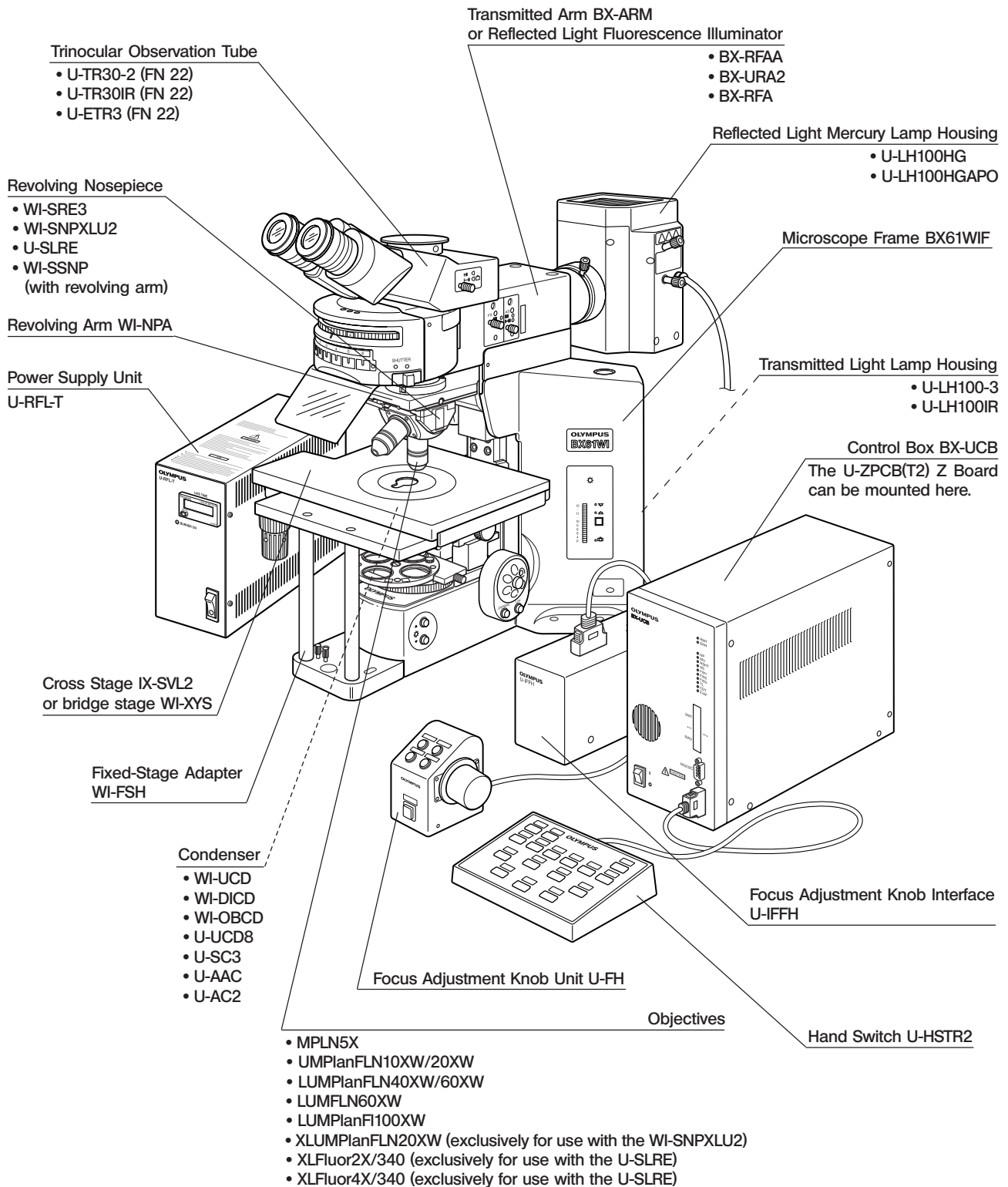

# 2 CONTROLS

© If you have not yet assembled the microscope, read Chapter 9, "ASSEMBLY" (pages 42 to 49).

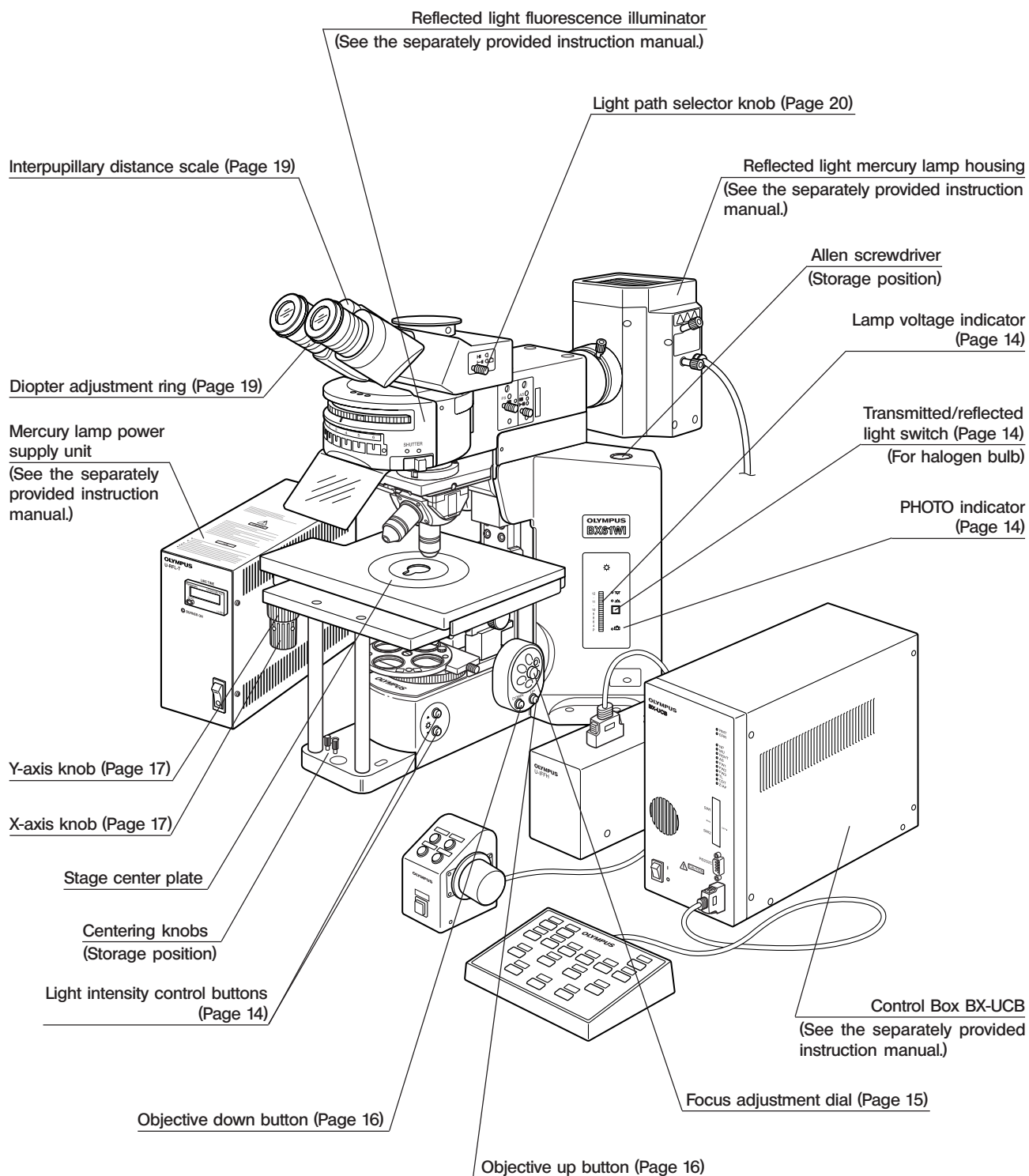

© The descriptions on the left side of the microscope frame, filter turret, revolving nosepiece, condenser, etc. will be given in the subsequent pages.

## Left Side View of Microscope Frame

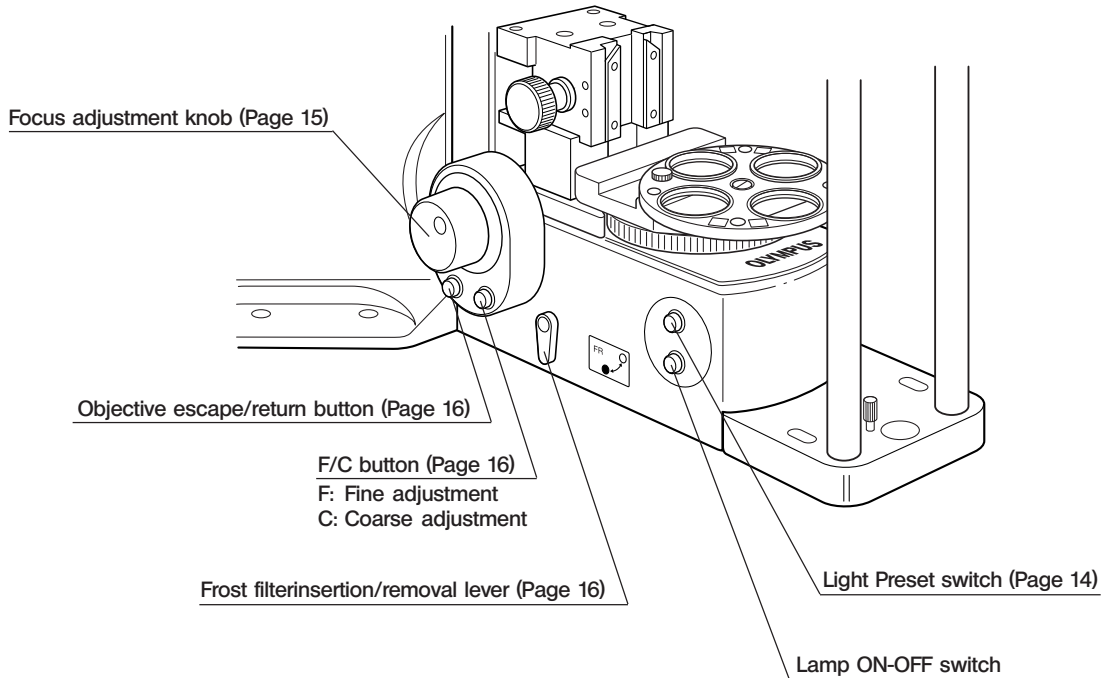

## Filter Turret

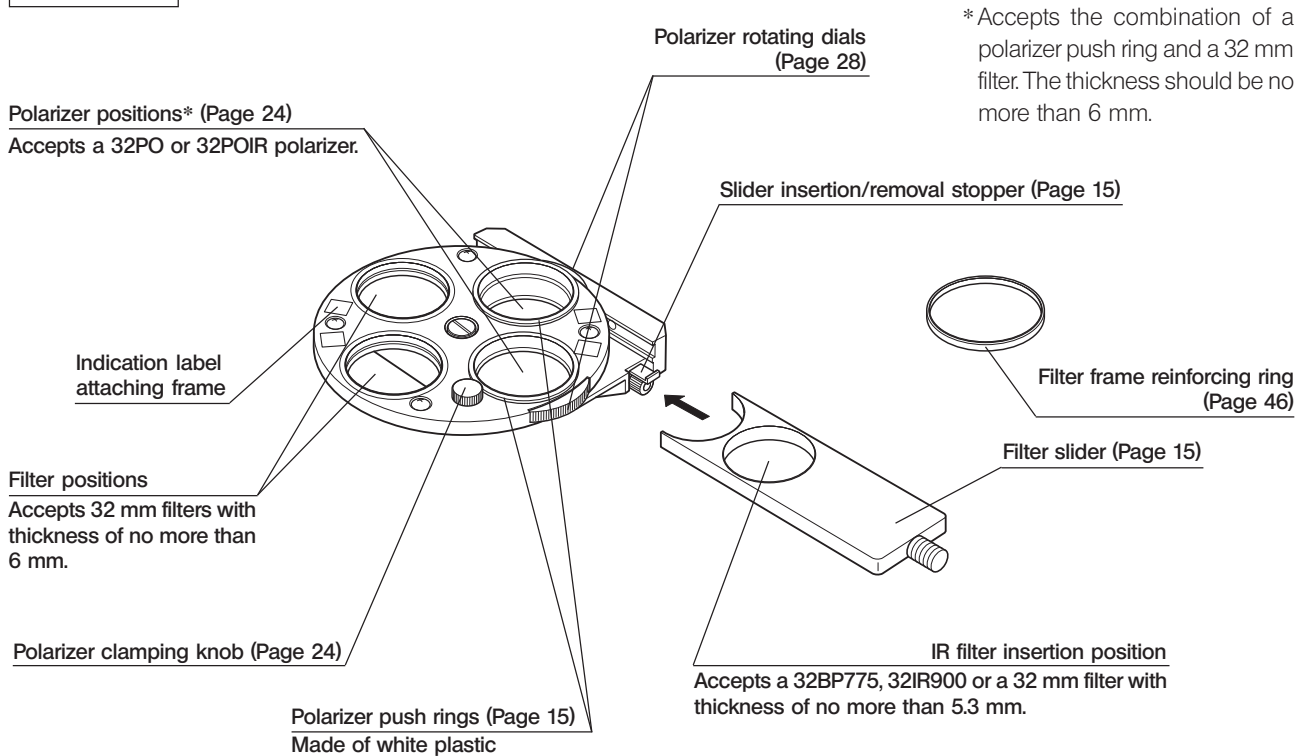

**Revolving Arm WI-NPA**

★ Note that the revolving arm can be mounted only before the reflected light illuminator or transmitted light arm and the IX-SVL2 stage are mounted (page 45).

© This revolving arm accepts the U-SLRE, WI-SNPXLU2 or WI-SRE3 revolving nosepiece.

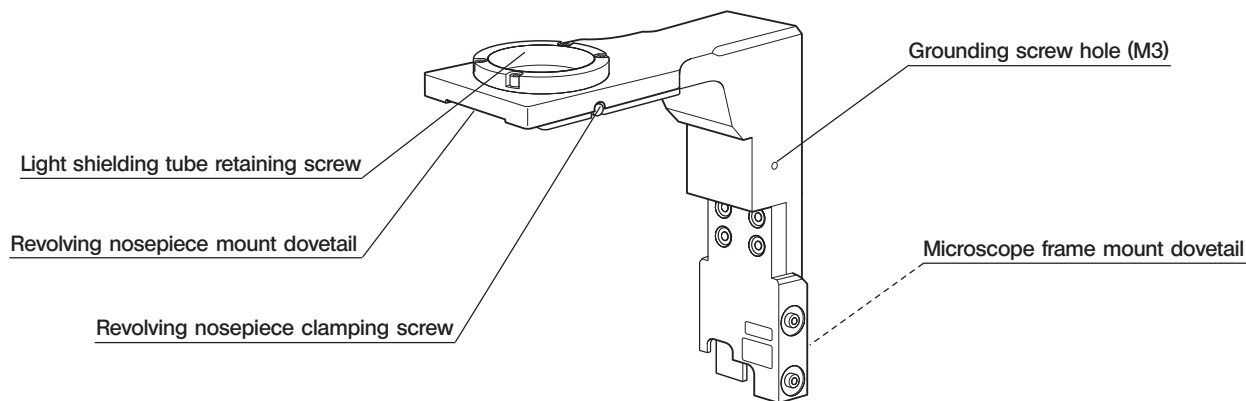

**Sliding Revolving Nosepiece U-SLRE**

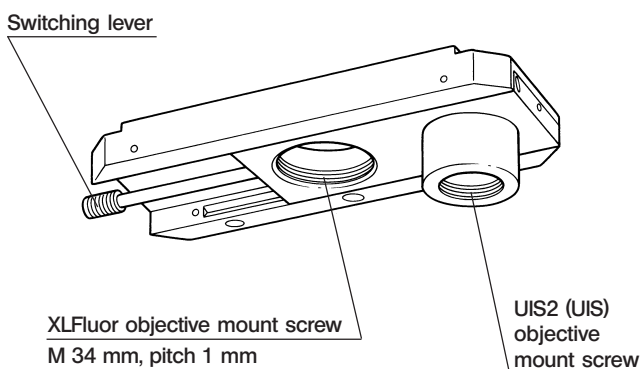

**Single-Position Revolving Nosepiece XLU WI-SNPXLU2**

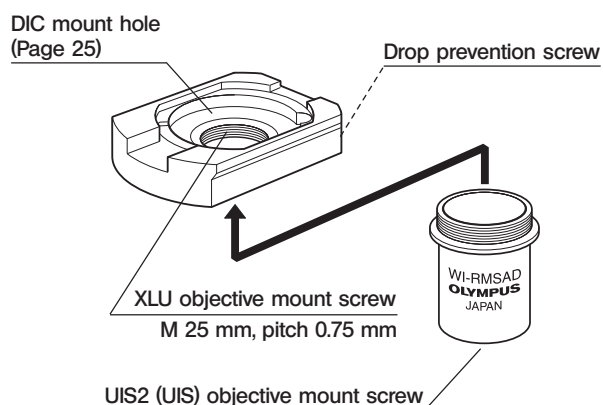

**RMS Adapter WI-RMSAD**

**Swinging Revolving Nosepiece WI-SRE3**

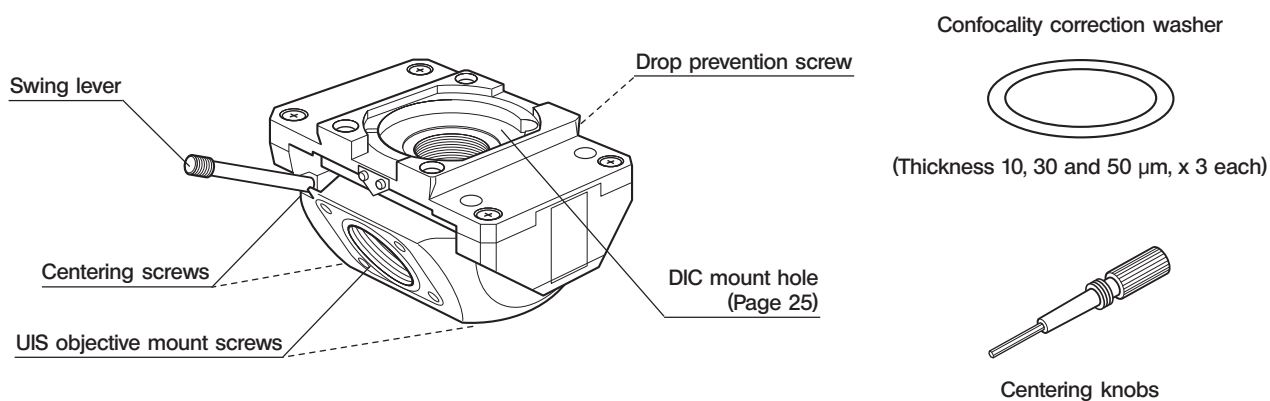

### Long-WD Universal Condenser WI-UCD

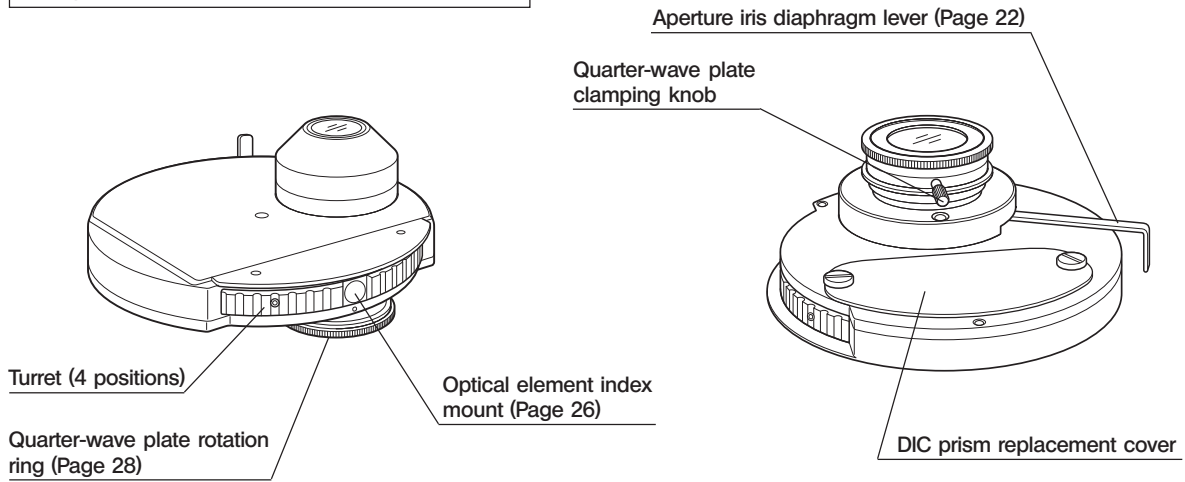

### Long-WD DIC Condenser WI-DICD

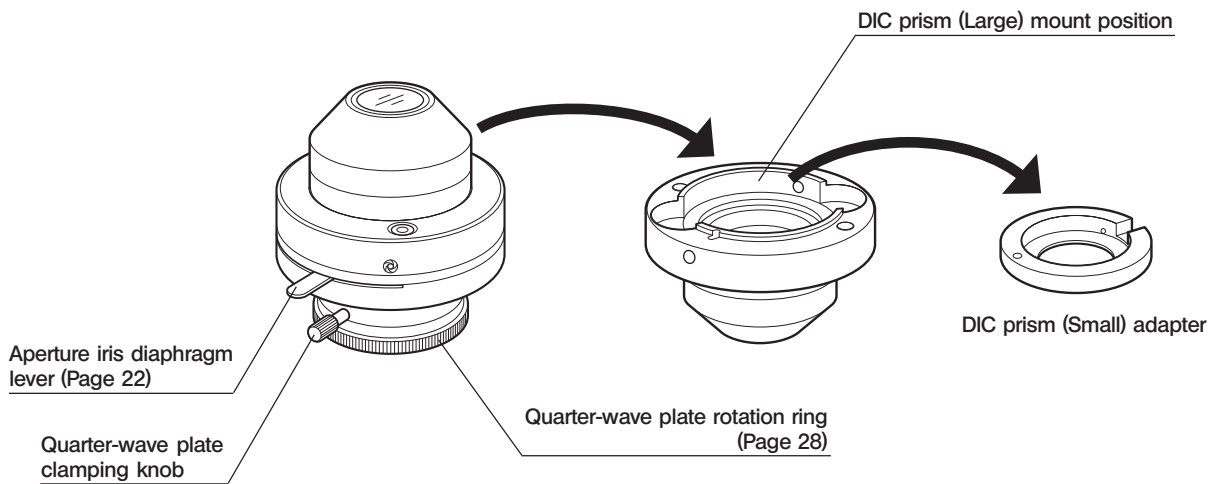

### Differential Interference Contrast Prisms (For Condenser)

©The WI-UCD condenser accepts two large and two small DIC prisms while the WI-DICD condenser accepts one large or small DIC prism.

When selecting the brightfield (BF) light path using the WI-UCD, leave one DIC prism (large) mount position empty.

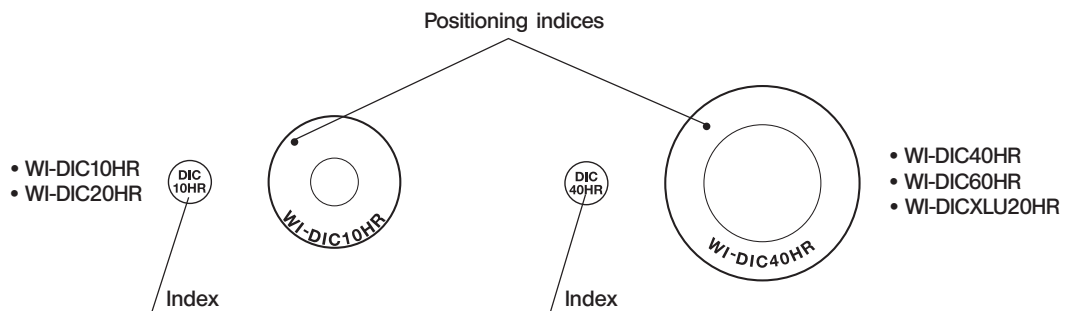

**Long-WD Oblique Condenser WI-OBCD**

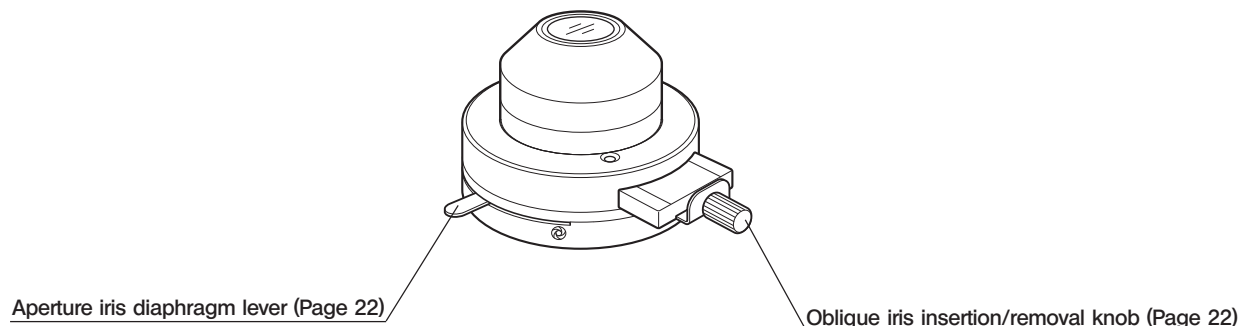

**High-Resolution DIC Prism A WI-DICTHRA2  
DIC Prism WI-DICT2**

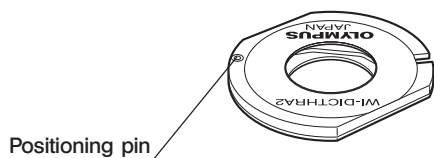

© This prism can be mounted in the DIC prism position of the WI-SNPXLU2 or WI-SRE3.

**Applicable condensers**

WI-DICTHRA2: WI-UCD, W-DICD  
WI-DICT2: U-UCD8

■ Condensers and Applicable Objective Magnifications

Condenser	Applicable Objective Magnification
WI-UCD WI-DICD WI-OBCD	5X or more
U-UCD8 U-SC3	2X or more
U-AAC	10X or more
U-AC2	5X or more

©The following modules are required to eliminate electrical noise, which may affect the potential measurement data during patch clamping.

**Halogen Lamp Power Supply TH4** (See the separately provided instruction manual for details.)

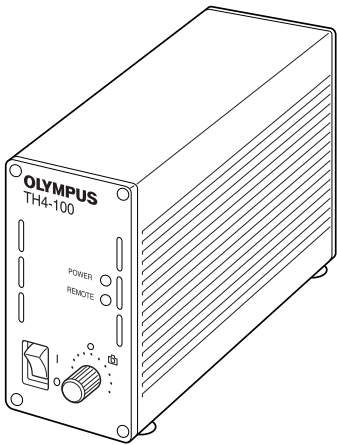

**Hand Switch TH4-HS**

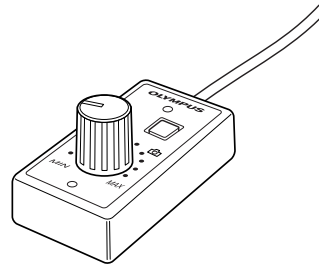

**Focus Adjustment Knob Interface U-IFFH**

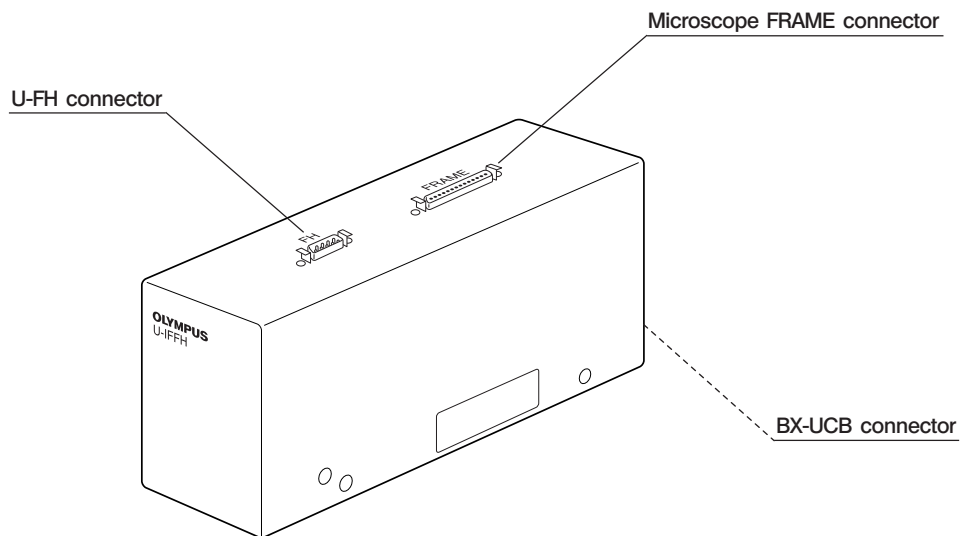

**Focus Adjustment Knob Unit U-FH**

The button functions described below are those when the microscope is used stand-alone.  
 The buttons functions inside  are the initial setups for PC control (remote operation).  
 The button functions can also be assigned as required by the user. For the assignment, refer to the instructions for the BX2-BSW BX Software (Ver. 03.01 or higher).  
 After setting up the button functions, attach the provided stickers near the buttons. For the function abbreviations and symbols on the stickers, see the following table.

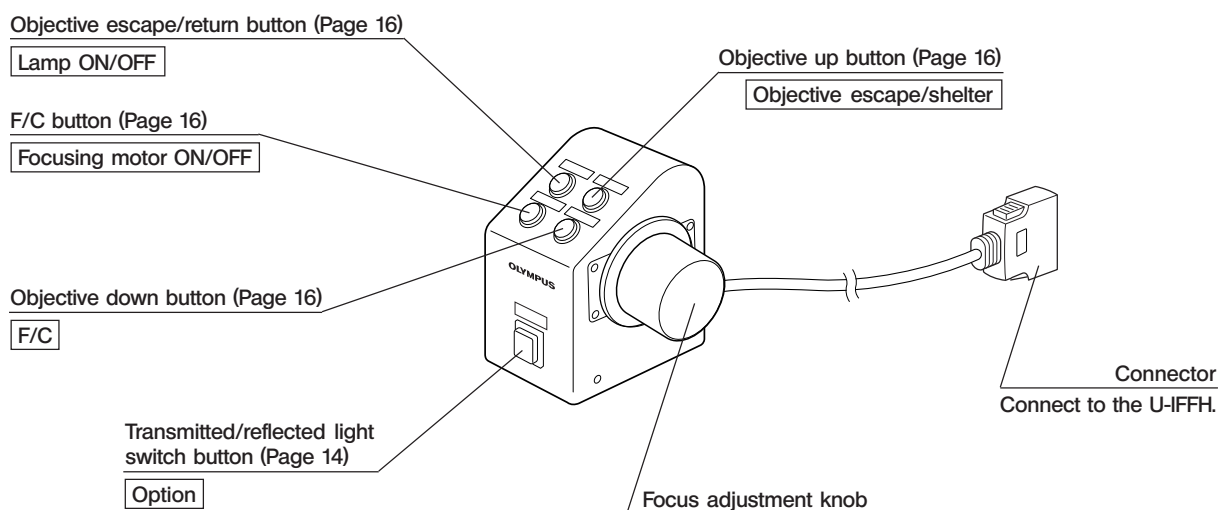

Abbreviations & Symbols	Function	Note
<span style="border: 1px solid black; padding: 2px; text-align: center;"><b>F/C</b></span>	Fine/Coarse switching	
<span style="border: 1px solid black; padding: 2px; text-align: center;">⏻</span>	Lamp ON/OFF	
<span style="border: 1px solid black; padding: 2px; text-align: center;">📷</span>	Set/cancel photo voltage	
<span style="border: 1px solid black; padding: 2px; text-align: center;"><b>FRM/FH</b></span>	Focus adjustment knob FRAME/U-FH	
<span style="border: 1px solid black; padding: 2px; text-align: center;"><b>Z.EX.</b></span>	Z-focusing motor ON/OFF	OFF: Electrical noise reduction
<span style="border: 1px solid black; padding: 2px; text-align: center;"><b>ESC</b></span>	Escape/return objective	
<span style="border: 1px solid black; padding: 2px; text-align: center;"><b>SHUT</b></span>	Shutter IN/OUT	
<span style="border: 1px solid black; padding: 2px; text-align: center;"><b>T.LENS</b></span>	Condenser top lens IN/OUT	Not used with the BX61WI.
<span style="border: 1px solid black; padding: 2px; text-align: center;">▼</span> <span style="border: 1px solid black; padding: 2px; text-align: center;">▲</span>	Up/down operation for brightness adjustment, objective, etc.	The function name can be written in the blank area using an oil-ink pen.
<span style="border: 1px solid black; padding: 2px; text-align: center;">◀</span> <span style="border: 1px solid black; padding: 2px; text-align: center;">▶</span>	Left/right operation of mirror unit, filter wheel, etc.	
<span style="border: 1px solid black; padding: 2px; text-align: center;"> </span>		

# 3 TRANSMITTED LIGHT BRIGHTFIELD OBSERVATION PROCEDURE

©The following flow shows the operating procedure for the transmitted light brightfield observation which is the basic observation method of this microscope. The operating procedures for DIC observation, fluorescence DIC observation and IR DIC observation will be described separately in Chapter 5, "OTHER OBSERVATION METHODS" on page 24.

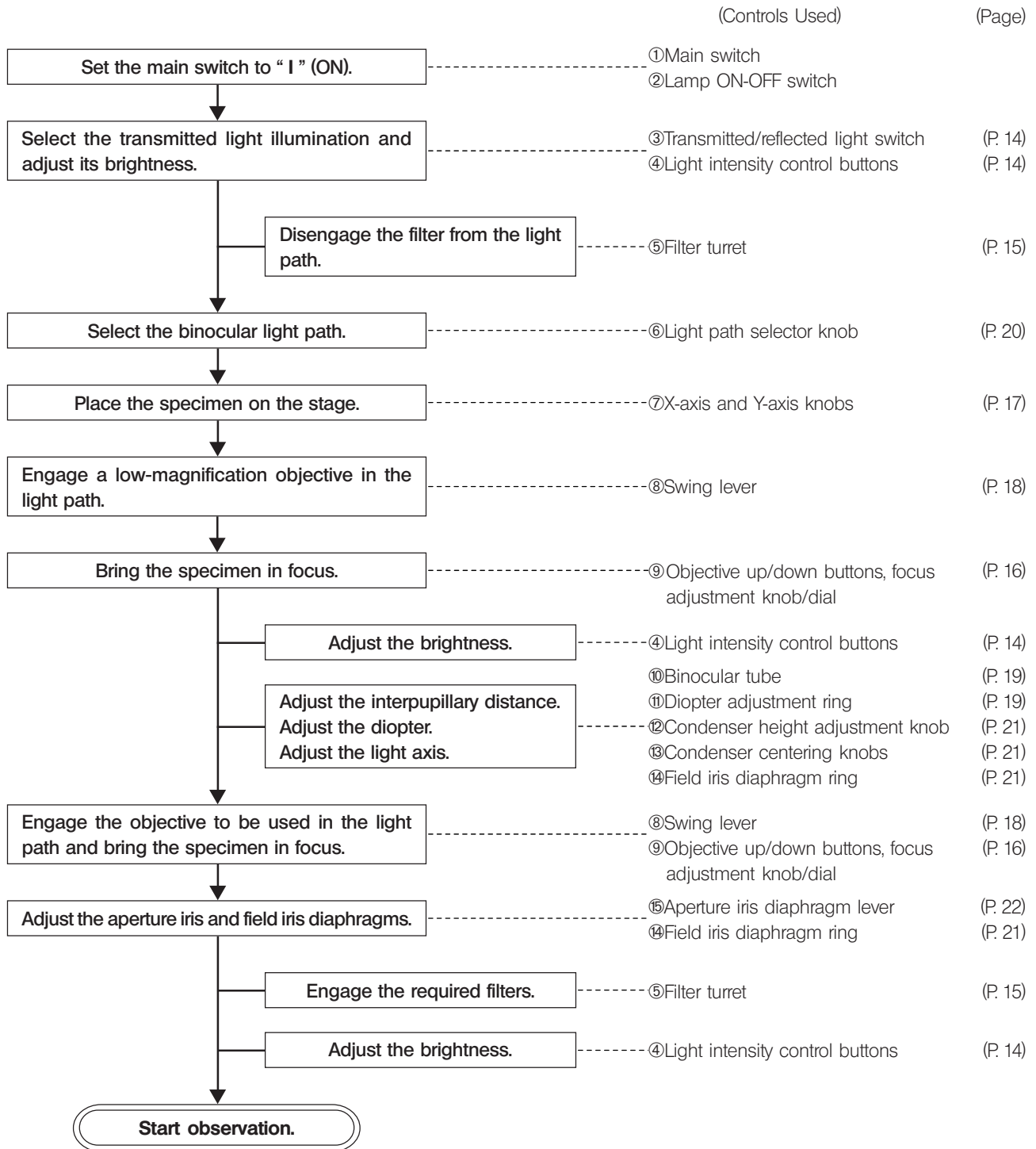

**Tip for microscope operation**  
In patch-clamp testing, switch the microscope controls cautiously and gently so that the patch electrodes do not slip off.

(Note) Controls with numbers inside □ can perform the same functions as the controls with numbers inside ○. However, the function of control 9 is not available when the U-FH is in use.

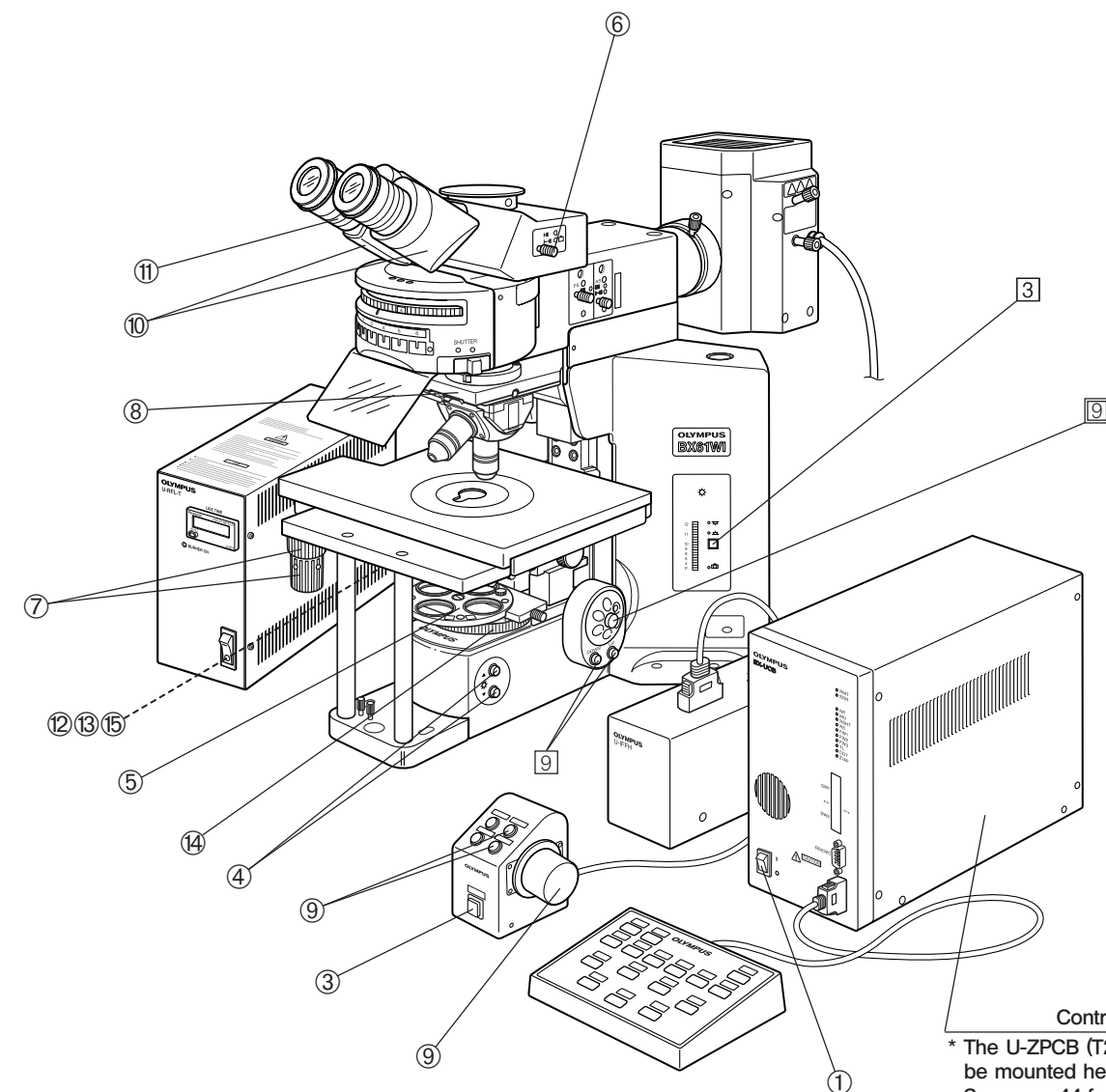

Control Box BX-UCB

\* The U-ZPCB (T2) Z board can be mounted here. See page 44 for the setup and installation of the Z board.

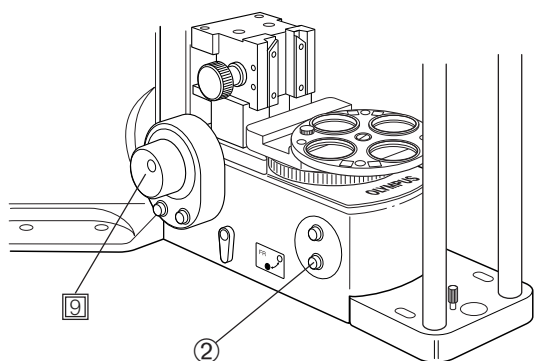

© Make a photocopy of the observation procedure pages and post it near your microscope.

# 4 USING THE CONTROLS

## 4-1 Microscope Frame

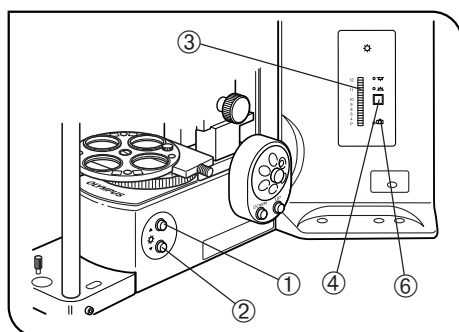

Fig. 3

### 1 Voltage Indication (Fig. 3)

1. Press the light intensity control button ① to increase the voltage and make illumination brighter.  
Pressing the button ② makes the illumination darker.
2. The numerals to the left of the lamp voltage indicator LEDs ③ indicate the reference values of the voltages.

★ The LEDs may turn off (temporarily) when the motor is driven, but the illumination intensity even if this occurs.

### 2 Transmitted/Reflected Light Switch (Fig. 3)

⊙ The same effect as this switch can also be obtained using the switch on the U-FH focus adjustment knob unit (see page 15).

The illumination can be switched between the transmitted light and reflected light by pressing the transmitted/reflected light switch ④.

☞ : Reflected light illumination

☞ : Transmitted light illumination

The LED indicator of the selected illumination lights.

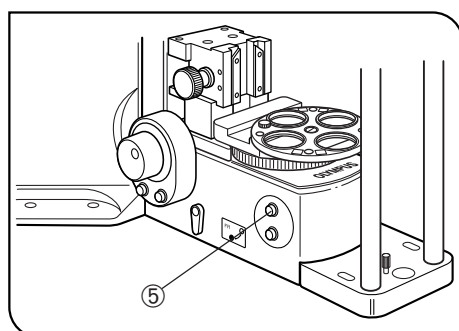

Fig. 4

### 3 Light Preset Switch (Fig. 4)

⊙ The Light Preset switch sets the light intensity voltage to a voltage suitable for color photography\* (the factory default is 9 V) regardless of the current setting of the light intensity control buttons.

\* Achieved by engaging the LBD filter.

#### Setting the Desired Brightness (Figs. 3 & 4)

1. Press the Light Preset switch ⑤. The PHOTO indicator LED ⑥ lights up.
2. Press one of the light intensity control buttons ① and ② to set the desired brightness.
3. Press the Light Preset switch again. The LED turns off, the brightness returns to the original brightness but the setting made above is stored in memory.
4. Hereafter, pressing the Light Preset switch sets the brightness to the intensity value set in step 2 above.

★ Be sure to return to the 9 V setting when performing color photography.

⊙ When the Light Preset switch ⑤ is pressed, an announcement tone (short beep) is generated at the 9 V position of the switch.

⊙ When the external TH-4 power supply unit is used instead of the microscope's built-in power supply circuitry, refer to the instruction manual provided with the TH4.

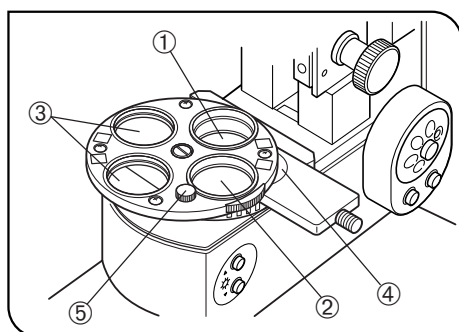

Fig. 5

#### 4 Using the Filter Turret

(Fig. 5)

- ◎ Filters with a diameter of 32 mm can be inserted in positions ① to ④.
- 1. Positions ① and ② are rotatable. When the 32PO or 32POIR polarizer is placed in either position, the polarizer can be fixed by means of the push ring (made of white plastic).
- ◎ When filter position ① is engaged in the light path, the polarizer clamping knob ⑤ comes at the front where the operation is easy.
- 2. Filter position ③ accepts any type of 32 mm filter.
- ★ When using two filters together, the thickness of the lower filter should be no more than 2 mm. Otherwise, the upper filter may drop during rotation.
- 3. Filter position ④ accepts the 32BP775 or 32IR900 IR filter. As the filter cannot be inserted unless the filter slider is removed, remove it by releasing the insertion/removal stopper below the slider and loosening the slider clamping screw using the provided Allen screwdriver.

## 4-2 Focusing Block

◎ The same effect as the focus adjustment knob on the microscope frame can also be obtained using the U-FH focus adjustment knob unit. However, when the microscope is used stand-alone while the cable to the U-FH is connected, the focus adjustment is available only from the focusing knob on the U-FH.

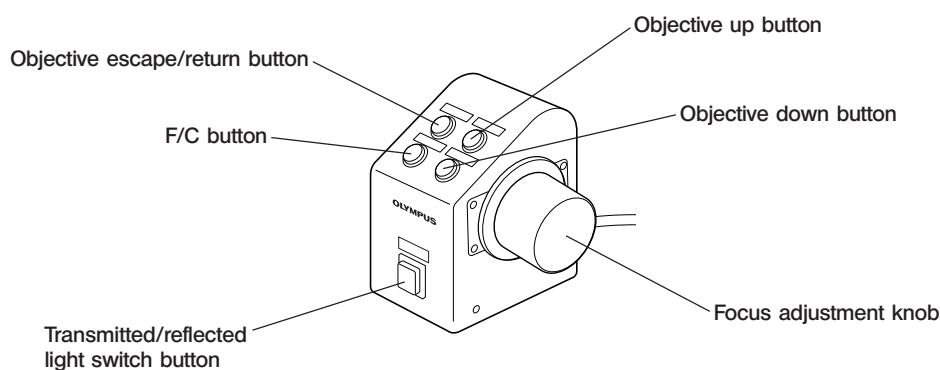

Focus Adjustment Knob Unit U-FH

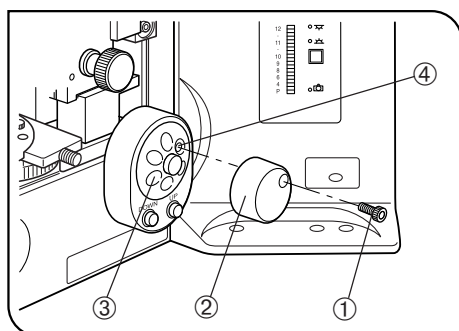

Fig. 6

#### 1 Replacing the Focus Adjustment Knob

(Fig. 6)

- ◎ The focus adjustment knob is installed on the right side of the microscope when it is shipped from the factory. (Detachable)
- 1. Loosen the clamping screw ① with the Allen screwdriver and remove the focus adjustment knob ②.
- 2. Remove the seal from the focus adjustment knob screw hole on the other side and attach the knob by reversing the removal procedure.
- 3. Attach a provided seal on the screw hole ④ of the removed focus adjustment knob ③.

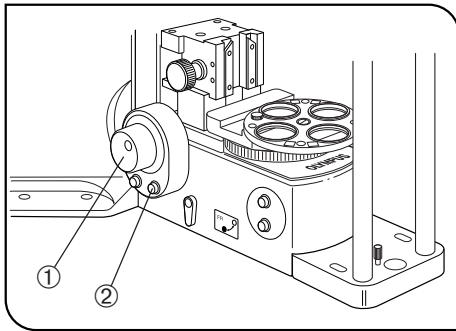

Fig. 7

## 2 F/C Button (Fig. 7)

Ⓞ The F/C button switches the function of the focus adjustment knob ① and focus adjustment dial between F (fine) and C (coarse). (For safety, the F/C button is set automatically to F at the moment the main switch of the BX-UCB control box is set to "I" (ON))

- Each press of the F/C button ② switches F and C alternately.

Objective fine movement:	0.1 mm per turn
Objective coarse movement:	0.3 mm per turn

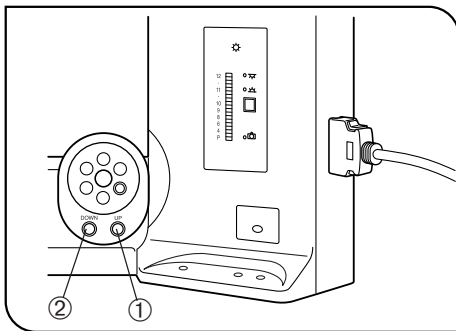

Fig. 8

## 3 Objective Up/Down Buttons (Fig. 8)

★ When the objective is lowered, be careful not to let it collide with the specimen.

- Press the objective up button ① to raise the objective and press the objective down button ② to lower the objective.
- The stroke is 25 mm.

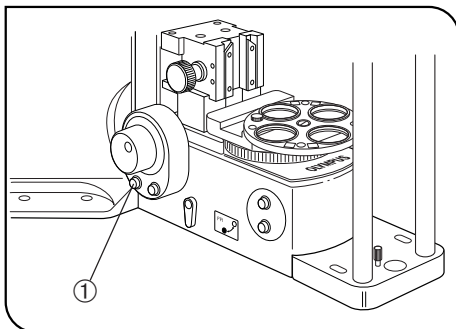

Fig. 9

## 4 Objective Escape/Return Button (Fig. 9)

When replacing the specimen, press the Objective Escape/Return button ① The objective will rise by 5 mm (in 1 sec.). Pressing the button again returns the objective to the original height.

★ Even after escaping, care is still required during objective switching, for the objective may still interfere with the edge of the container. If this happens, raise the objective higher using the objective up button.

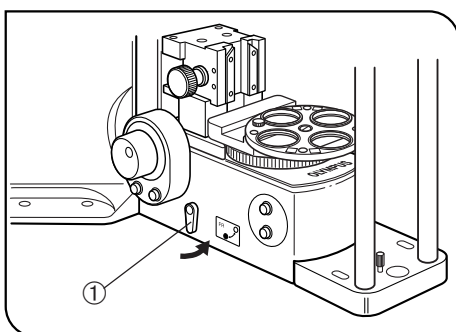

Fig. 10

## 5 Using the Frost Filter Insertion/Removal Lever (Fig. 10)

Ⓞ Low observation light can be brightened by turning the frost filter insertion/removal lever ① which controls the built-in frost filter, in the direction of the arrow. However, although the brightness is increased, irregularity in lighting may also increase.

## 4-3 Stage (IX-SVL2)

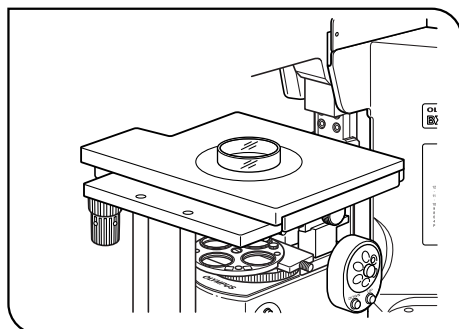

Fig. 11

### 1 Placing the Specimen (Fig. 11)

1. Place the specimen on the center of the stage.
- ◎ The optional stage center plate (IX-CP50) makes it possible to observe a wide range of a big petri dish, etc. (Central hole diameter: 50 mm)

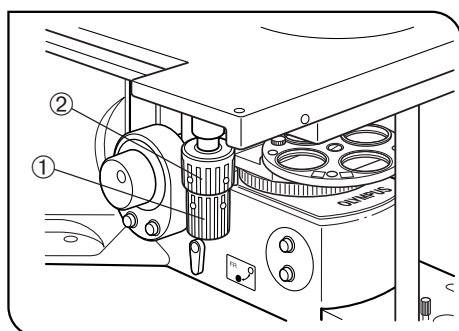

Fig. 12

### 2 Moving the Specimen (Fig. 12)

1. The specimen can be moved by turning the X-axis knob ① and Y-axis knob ②.
- The movement strokes are 50 mm (X-axis) x 43 mm (Y-axis).

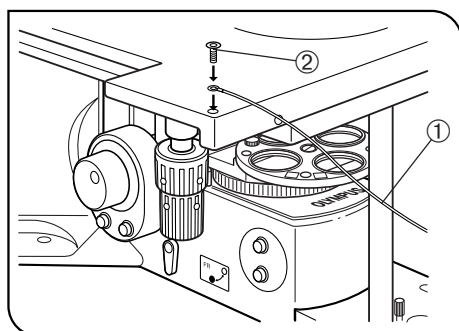

Fig. 13

### 3 Setting the Grounding (Fig. 13)

- ◎ In case of electrical physiological experiment, etc., the specimen can be grounded from the stage.
- Prepare a grounding wire ① and M4 screw ② and attach grounding as shown in Fig. 13.
- ★ The screw hole may sometimes be stuck by paint, etc. In such a case, screw in the M4 screw a few times to expose the metallic thread inside the screw hole and improve the contact before attaching the grounding wire firmly.

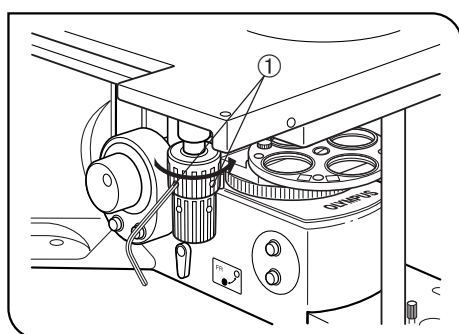

Fig. 14

### 4 Adjusting the X-Axis/Y-Axis Knob Rotation Tension (Fig. 14)

- ◎ The rotation tension of the X-axis and Y-axis knobs can be adjusted independently.
1. Loosen the 2 set screws ① of a knob using the provided Allen wrench, hold the stage so that it will not move, then turn the knob to adjust the tension. Turning it in the direction of the arrow increases the tension and turning in the opposite direction decreases the tension.
  2. After adjustment, tighten the set screws firmly.
- ★ If the tension of a knob is too heavy or too light, skipping or returning of image may occur during the stage movement.

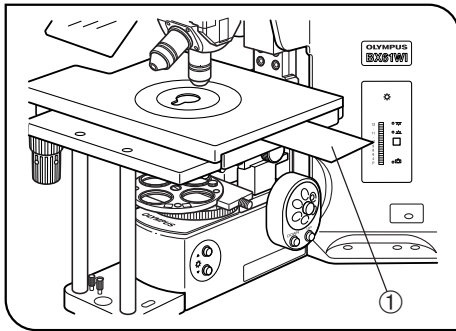

Fig. 15

## 5 Using the Light Shielding Sheet (Fig. 15)

★ The light shielding sheet provided with the reflected light fluorescence illuminator is too small to be used with the BX61WI. Always use the light shielding sheet provided with the BX61WI.

⊙ During fluorescence observation using a low-magnification objective, the fluorescence image may be deteriorated due to light reflected from the condenser or the surroundings. In this case, use the light shielding sheet.

1. Lower the condenser to the lower limit position using the condenser height adjustment knob.
2. Insert the light shield sheet ① all the way into the gap between the upper and lower stages on the side of the stage (IX-SVL2).

★ If the condenser is lowered insufficiently, the sheet cannot be inserted into the normal position and the light shielding effect cannot be obtained.

## 6 Lowering the Stage Height

The stage can be lowered by 50 mm by removing the condenser holder. See page 49 for details.

## 4-4 Revolving Nosepiece

▲ If the petri dish in use is filled with liquid, it may splash when the objective is switched. As such liquids are sometimes toxic, be sure to move the revolving nosepiece away from the petri dish before switching the objective. Even after the revolving nosepiece has been moved, re-focusing is easy by making use of the objective escape/return button (page 16).

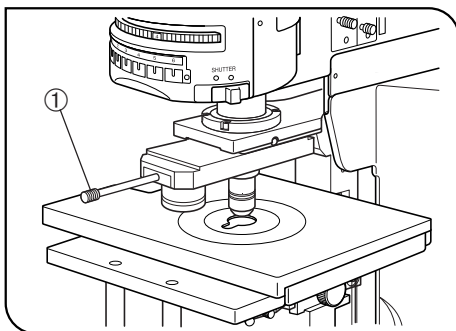

Fig. 16

## 1 Switching the Objectives (Figs. 16 & 17)

⊙ The clicking force of the revolving nosepiece has been set weak in order to reduce vibrations during objective switching. To reproduce the correct click position, switch the objectives gently by operating the lever.

### Sliding Revolving Nosepiece U-SLRE

Switch the objective by holding the objective switching lever ① and gently moving it back and forth.

⊙ By attaching the objective switching lever ① on the opposite side, a UIS objective can be positioned on the front side of the microscope.

### Swinging Revolving Nosepiece WI-SRE3

Switch objectives by gently pulling up or pushing down the swing lever ①. Handle the lever gently till it contacts a stopper on the revolving nosepiece.

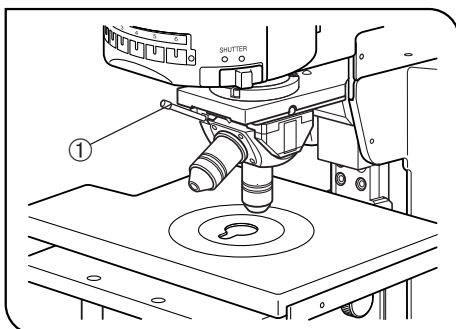

Fig. 17

## 4-5 Observation Tube

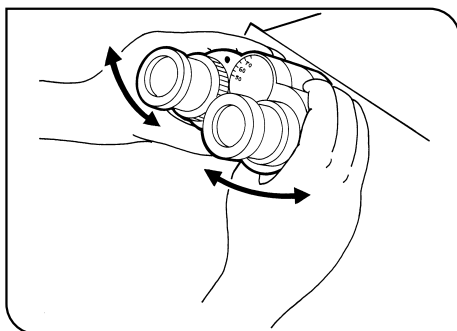

Fig. 18

### 1 Adjusting the Interpupillary Distance (Fig. 18)

While looking through the eyepieces, adjust for binocular vision until the left and right fields of view coincide completely. The index dot • indicates the interpupillary distance.

©Note your interpupillary distance so that it can be quickly duplicated.

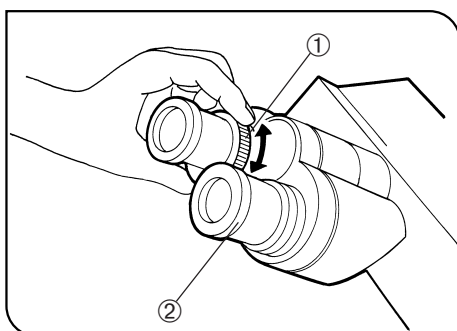

Fig. 19

### 2 Adjusting the Diopter (Figs. 19 & 20)

1. Looking through the eyepiece without the diopter adjustment ring, adjust the focusing using the objective up/down buttons to bring the specimen into focus.
2. Looking through an eyepiece sleeve with the diopter adjustment ring ① turn only the ring to focus on the specimen. (Fig. 19)

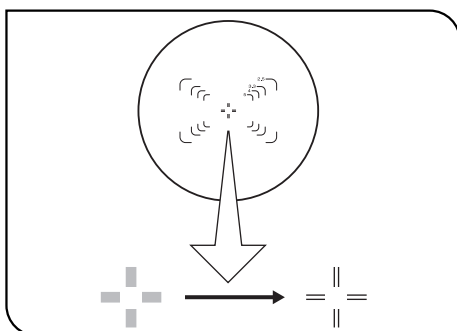

Fig. 20

#### Using Finder Eyepieces

1. Looking through the right eyepiece with your right eye, turn the top of the eyepiece ② until a clearly defined double crosslines can be seen in the field of view. (Figs. 19 & 20)
2. Looking through the right eyepiece, adjust the focusing using the objective up/down buttons to bring the specimen and double crosslines into simultaneous focus.
3. Looking through the left eyepiece with your left eye, turn the diopter adjustment ring ① to focus on the specimen.

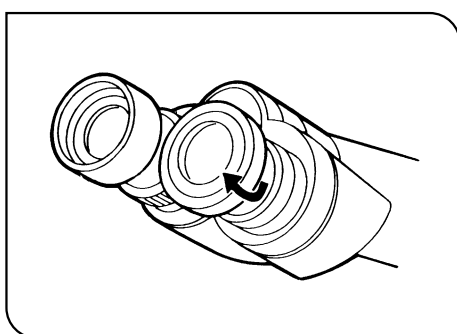

Fig. 21

### 3 Using the Eye Shades (Fig. 21)

#### When Wearing Eyeglasses

Use with the eye shades in the normal, folded-down position. This will prevent the eyeglasses from being scratched.

#### When Not Wearing Eyeglasses

Extend the folded eye shades in the direction of the arrow to prevent extraneous light from entering between the eyepieces and eyes.

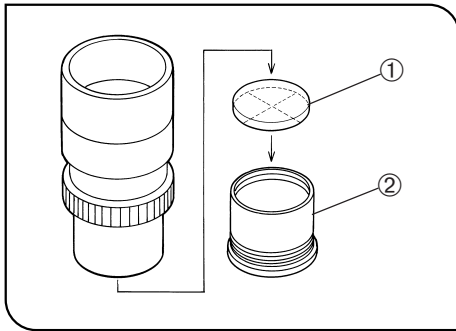

Fig. 22

#### 4 Using Eyepiece Micrometer Disks (Fig. 22)

Eyepiece micrometer disks can be inserted into the WHN10X-H (or WHN10X) eyepieces.

Use 24 mm dia. x 1.5 mm micrometer disks.

Following Fig. 22, remove the micrometer mounting frame ② from the eyepiece and place a micrometer disk ① into the mounting frame so that the surface with the model indication faces downward.

Re-attach the micrometer mounting frame in the original position.

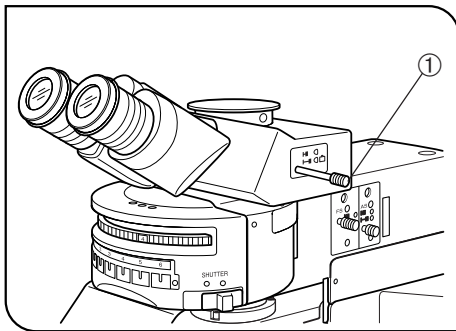

Fig. 23

#### 5 Selecting the Light Path of Trinocular Tube (Fig. 23)

Slide the light path selector knob ① to select the desired light path.

Trinocular Tube	Light Path Selector Position		
	Pushed In	Intermediate	Pulled Out
U-TR30-2	Binocular 100%	Binocular 20%, TV/photo 80%	TV/photo 100%
U-ETR3	Binocular 100%		TV/photo 100%
U-TR30IR	Binocular 100%	Shuttered	TV/photo 100%

## 4-6 Condenser

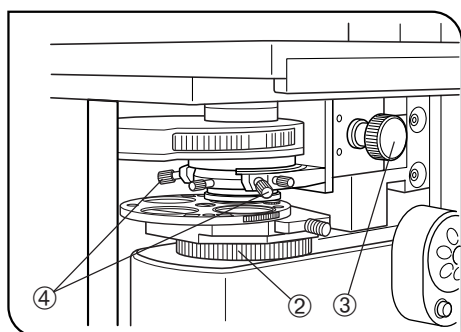

Fig. 24

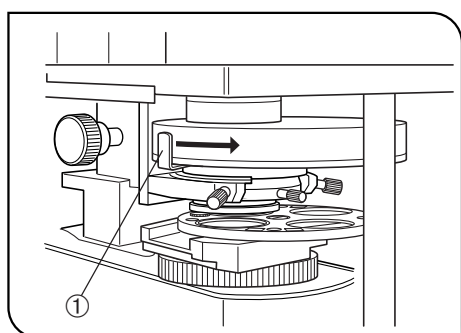

Fig. 25

### 1 Centering the Condenser

(Figs. 24 to 26)

1. Set the aperture iris diaphragm lever ① to the open position. (Fig. 25)
  2. Set the field iris diaphragm ring ② to the open position (⊗ → ○). (Fig. 24)
  3. Focus on the specimen using the 10X objective.
  4. Close the field iris diaphragm ring ② so that the diaphragm image comes inside the field of view.
  5. Manipulate the condenser height adjustment knob ③ to focus on the diaphragm image.
  6. Turn the two condenser centering knobs ④ on the condenser holder to move the iris diaphragm image to the center of the field of view. (Fig. 24, Fig. A → Fig. B).
  7. Gradually open the field iris diaphragm. The condenser is properly centered if the iris image is centered and inscribed in the field of view (Fig. B → Fig. C).
- Ⓞ During actual use, open the field diaphragm slightly until its image circumscribes the field of view.

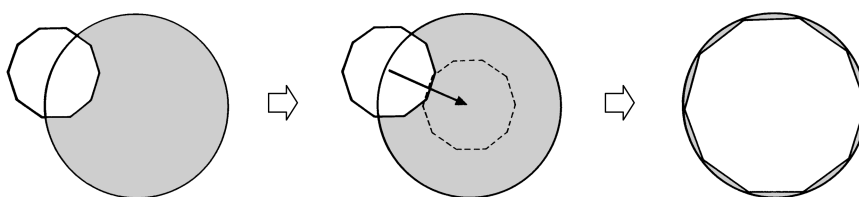

Fig. A

Fig. B

Fig. C

#### Field Iris Diaphragm

The field iris diaphragm restricts the diameter of the beam of light entering the objective and thus excludes extraneous light, improving image contrast. The diameter of the field iris should be adjusted for objective magnification to the extent that it just circumscribes the field of view.

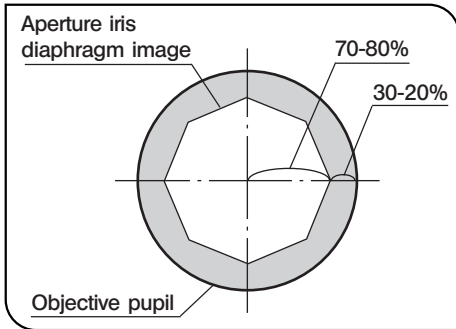

Fig. 26

#### Aperture Iris Diaphragm

- The aperture iris diaphragm determines the numerical aperture of the illumination system. Matching the numerical aperture of the illumination system with that of the objective provides better image resolution and contrast, and also increases the depth of focus.
- Since the contrast of microscope specimens is ordinarily low, setting the condenser aperture iris diaphragm to between 70% and 80% of the NA of the objective in use is usually recommended. If necessary, adjust the ratio by removing the eyepieces and looking into the eyepiece sleeve while adjusting the aperture iris diaphragm lever ① until the image shown in Fig. 26 is seen. (Fig. 25)

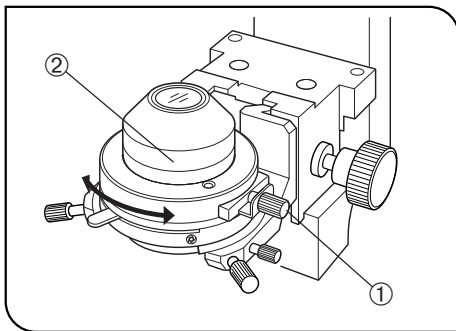

Fig. 27

## 2 Oblique Illumination (WI-OBCD) (Figs. 27 & 28)

☉ The shading and 3D feeling of the specimen can be adjusted by varying the width and orientation of the area subjected to oblique illumination. This is possible with objectives from 5X to 100X.

★ When the XLUMPlanF120XW objective is used, oblique illumination cannot provide a satisfactory effect due to the high NA (0.95) of the objective.

#### IMPORTANT

The effect of oblique illumination assumes that the field iris image is focused correctly.

Before proceeding to the following, pull out the oblique iris insertion/removal knob ① and bring the field iris image in focus (this is the same operation as that described on page 21).

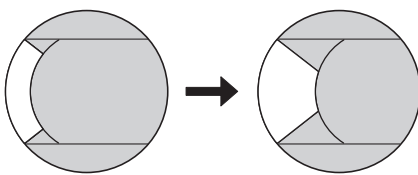

Fig. 28

1. Push in the oblique iris insertion/removal knob ①.
2. Turn the knob ① to adjust the width of the area illuminated by oblique illumination. (Fig. 28)
3. Adjust the orientation of the oblique illumination by turning the top part ② of the condenser.

☉ Pull out the oblique iris insertion/removal knob when using the condenser as usual.

The width of the oblique illumination area is maintained even after the insertion/removal knob ① has been pulled out, so the same condition can be reproduced the next time the knob is pushed in.

## 4-7 Water Immersion Objectives

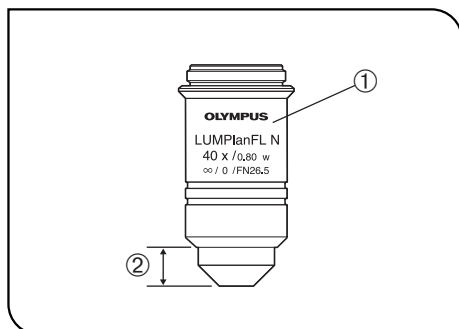

Fig. 29

### 1 Using Water Immersion Objectives (Figs. 29 & 30)

©When the UMPlanFLN series, LUMPlanFLN series or XLUMPlanFI20XW objective is used, cultured tissue specimens which are often very thick can be observed by immersing the specimen, objective front lens and manipulator extremity in a medium (water) with the same refractive index.

★ The electrically insulated area and immersion depth of the objective ① are shown by the range of ②.

#### CAUTION

Do not immerse the entire objective, for this will cause malfunction.

After every immersed use, be sure to clean the front lens with neutral detergent.

#### Water Immersion Cap for XL Objectives XL-CAP

In photometry with a film potential-sensitive fluorochrome, the water surface fluctuations can be reduced and S/N can be improved by fitting this cap ② onto the top of the objective ① (XLFluor2X/340 or XLFluor4X/340).

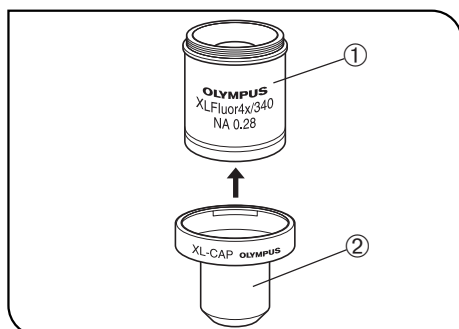

Fig. 30

# 5 OTHER OBSERVATION METHODS

## 5-1 Differential Interference Contrast Observation

★ The normal optical performance of DIC observation cannot be manifested if a plastic petri dish is used.

⊙ DIC prisms (for revolving nosepiece and condenser), an analyzer and a polarizer are required for DIC observation.

When the reflected light fluorescence illuminator is not used, the U-KPA intermediate tube is required to attach the analyzer.

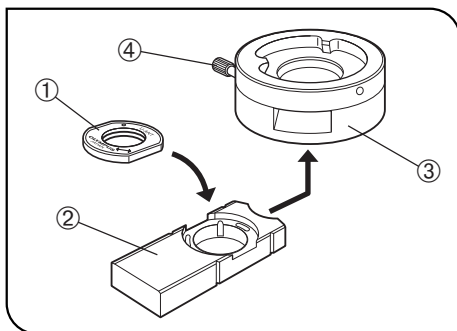

Fig. 31

### 1 Attaching the Analyzer (Fig. 31)

#### U-ANT Analyzer

⊙ Drop the U-ANT analyzer in the dummy slider of the U-KPA intermediate tube.

1. Place the U-ANT ① with the side with indications facing up, align the indices and drop the analyzer into the dummy slider ② (the analyzer will be absorbed by magnet).
2. Set the dummy slider ② back into the U-KPA ③ and tighten the clamping knob ④.

#### U-AN Analyzer

⊙ Insert the U-AN into the analyzer insertion slot of the reflected light fluorescence illuminator. (Refer also to the instruction manual of your reflected light fluorescence illuminator)

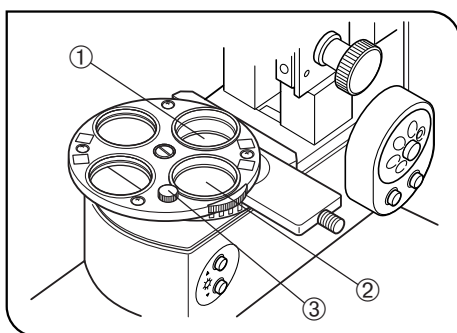

Fig. 32

### 2 Attaching the Polarizer (Figs. 32 & 33)

⊙ The performance of a polarizer deteriorates after it has been subjected to light for a long period (about 500 hours of continuous use). Replace the polarizer when it has been used for a long period.

Drop the polarizer into the filter insertion position with a push ring ① or ②, and clamp with the push ring.

⊙ It is recommended to insert the polarizer in insertion position ①. This is because the polarizer rotation clamping knob ③ comes on the front of the microscope when the insertion position ① is engaged in the light path.

⊙ When the 32PO polarizer is used, adjustment is easier than with the 32POIR since images are brighter with the 32PO.

Besides, removal of the IR filter (32BP775 or 32IR900) makes images brighter during adjustment although infrared light observation is to be performed.

#### When Using the U-UCD8

★ The polarizer built into the U-UCD8 is not necessary with this microscope. Remove it as described below.

1. Using a Phillips precision screwdriver, remove the 6 clamping screws ① retaining the polarizer cover at the bottom side of the condenser. (Fig. 33)
2. Remove the cover to expose the polarizer and remove it together with the frame. (Retain the removed polarizer carefully for future use with a microscope other than the BX61WI.)
3. Attach the polarizer cover to the original position.

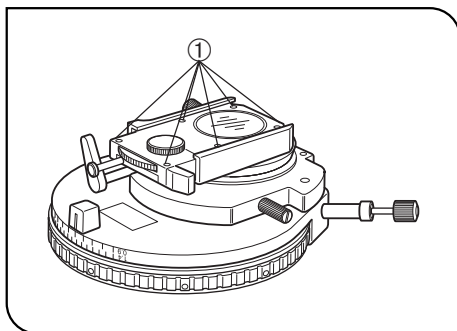

Fig. 33

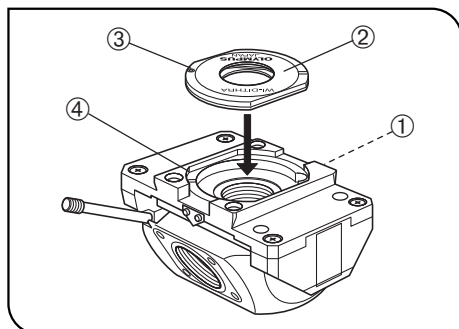

Fig. 34

### 3 Attaching the DIC Prisms (for Revolving Nosepiece) (Fig. 34)

◎The DIC prisms for use in the revolving nosepiece include the W-DICTHRA2 (high-resolution type) and WI-DICT2 (middle-contrast type). The revolving nosepieces in which a DIC prism can be inserted are the WI-SRE3 and WI-SNPXLU2.

The DIC prisms (WI-DICT or WI-DICTHRA) cannot be attached to the revolving nosepieces (WI-SRE3 or WI-SNPXLU2) because of their shapes and sizes.

1. Remove the revolving nosepiece from the revolving arm, then fully loosen the drop prevention screw ① with a Phillips precision screwdriver.
2. Hold a DIC prism ② with the side with indications facing up, and insert it by aligning the positioning pin ③ with the groove ④ on the revolving nosepiece.

After the insertion, tighten the drop prevention screw ① securely.

3. Attach the revolving nosepiece onto the revolving arm.

### 4 Attaching the DIC Prisms (for Condenser) (Figs. 35 to 38)

◎DIC prisms can be inserted in three types of condensers including the WI-UCD, WI-DICD and U-UCD8\*.

\* Do not use the U-UCDTP530 one-wave plate for the U-UCD8 but use the exclusive WI-TP137 quarter-wave plate.

#### ■ List of DIC System Combinations

		Shearing Amount	
		Small (High resolution)	Medium (Middle contrast)
Condenser		WI-UCD WI-DICD	U-UCD8 (with WI-TP137)*
DIC prism (for revolving nosepiece)		WI-DICTHRA2	WI-DICT2
Objective		DIC prism (for condenser)	
Magnification	10X	WI-DIC10HR (small)	DIC10
	20X	WI-DIC20HR (small)	—
	40X	WI-DIC40HR (large)	DIC40
	60X	WI-DIC60HR (large)	DIC60
	100X		DIC100
	XLU20X	**WI-DICXLU20HR	—
Application	CCD observation (Surface to deep)	Observation of relatively shallow area (0 to 100 μm)	Observation of relatively deep area (50 to 150 μm)
	Binocular observation (Surface layer only)	Optimum for surface layer observation.	Less suitable for surface layer observation than the high-resolution type.

\*\* The actual view is equivalent to the middle-contrast type because of lower magnification and higher NA than usual.

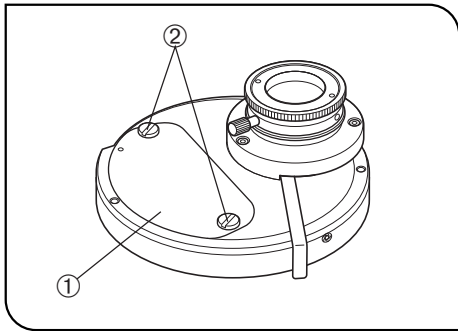

Fig. 35

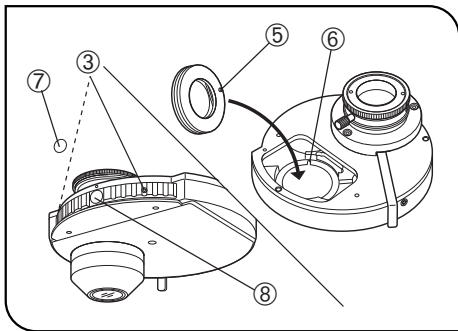

Fig. 36

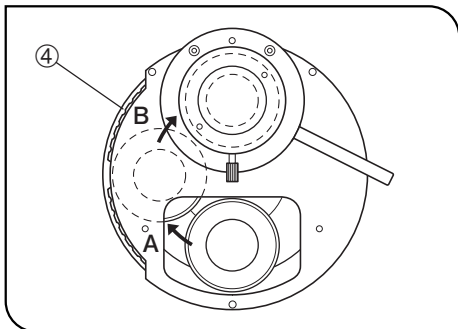

Fig. 37

#### With the WI-UCD Condenser (Figs. 35 - 37)

Ⓞ When selecting the brightfield (BF) light path using the WI-UCD, leave one DIC prism (large) mount position empty.

1. Remove the WI-UCD condenser from the microscope frame.
2. Remove the condenser cover ① by loosening the retaining screws ② using a coin, etc.

3. Attach the suitable DIC prism for the objective in use as described below.
  - Using the dedicated knob provided with the condenser, loosen the two DIC prism clamping screws ③ until the rotatable limits.
  - Rotate the turret by 90° counterclockwise, and drop in the DIC prism by aligning its positioning pin ⑤ with the positioning groove ⑥ in the hole of the turret ④ (Fig. 36).

★ **Be careful not to touch the prism inside the frame.**

- A. Rotate the turret ④ by 90° clockwise (Fig. 37) and tighten the two DIC prism clamping screws ③ uniformly using the dedicated knob provided with the condenser. (Figs. 36 & 37)

★ **Do not tighten the screws too much, or the prism frame may be deformed.**

- B. Rotate the turret ④ by 90° clockwise (Fig. 37), and attach the index sticker ⑦ provided with the DIC prism onto the side ⑧ of the condenser turret ④ so that the index sticker is upside down. (Figs. 36 & 37)

4. After attaching all of the required DIC prisms, attach the cover ① and tighten the retaining screws ②. (Fig. 35)

5. Attach the condenser back onto the microscope frame.

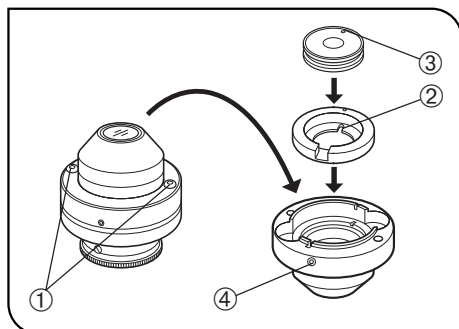

Fig. 38

**With the WI-DICD Condenser (Fig. 38)**

⊙The WI-DICD should be attached after completing the polarizer position as described in item **5**.

1. Remove the WI-DICD condenser from the microscope frame.
2. Remove the two clamping screws ① using the Allen screwdriver provided with the microscope, then place the top of the condenser upside down.
3. When the DIC prism for use with the objective in use is a small DIC prism, drop it in by aligning the positioning groove ② on the adapter located on the inner side with the pin ③ of the prism.

When the DIC prism for use with the objective is a large DIC prism, remove the adapter and drop in the DIC prism.

⊙Retain the adapter for future possible use.

4. Tighten the clamping screws ④ with the knob provided with the condenser.
5. Attach the condenser on the microscope again.

**With the U-UCD8**

⊙Attach the DIC prism by referring to the instruction manual provided with the U-UCD8.

**5 Adjusting the Polarizer Position (except the U-UCD8) (Fig. 39)**

★ This adjustment is not necessary when the U-UCD8 is used. However, be sure to insert the WI-TP137 quarter-wave plate in a position where the U-UCDTP530 one-wave plate for the U-UCD8 is otherwise inserted.

⊙This adjustment is possible without removing the DIC prism (for revolving nosepiece). However, it is not possible if a DIC prism for condenser is engaged in the light path. Remove or disengage the DIC prism for condenser as described below.

- WI-DICD: Remove the DIC prism.
- WI-UCD : Rotate the turret to engage a position without DIC prism.

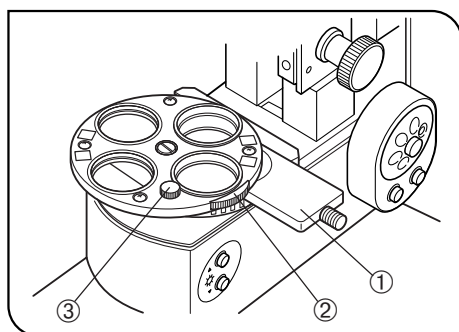

Fig. 39

**When the U-LH100IR Lamp Housing Is Used**

▲ Be sure to take the following measure to protect your eyes from the IR rays.

⊙Insert the IR cut filter (light blue) provided with the microscope into the filter slider ① then push it in to engage it.

1. Remove the condenser from the microscope.
2. Remove an objective and engage the position without the objective in the light path.
3. Engage the polarizer and analyzer in the light path (page 24) and turn the transmitted light on.

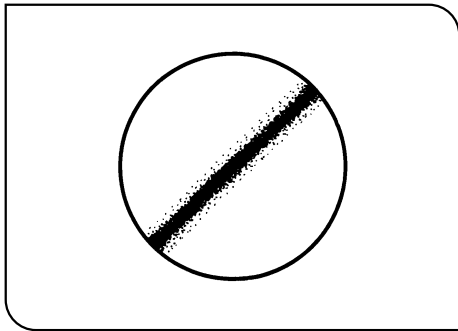

Fig. 40

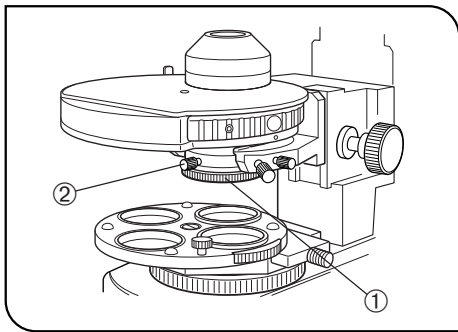

Fig. 41

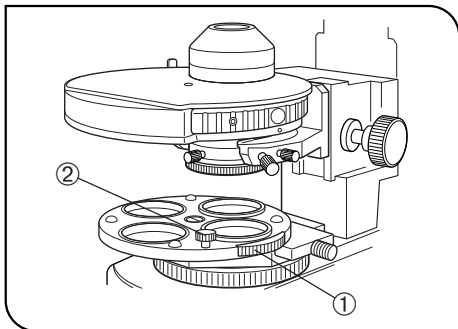

Fig. 42

4. Remove the eyepiece from the eyepiece sleeve, look into the sleeve, turn the polarizer rotation dial ② so that the black interference stripe (Fig. 40) is darkest, and tighten the clamping knob ③.
5. Engage an objective (as low-magnification as possible) in the light path, attach the condenser and bring the specimen surface into focus.

**IMPORTANT**

The interference stripe is less clearly visible when the specimen is thick. In this case, it is recommended to bring a scratch or like on the bottom of the petri dish to facilitate the subsequent adjustment operation.

- ⊙With the WI-DICD, do not attach the DIC prism. With the WI-UCD, engage a position without DIC prism in the light path.
- 6. If the condenser has not been centered yet, center it (page 21).
- ⊙The interference stripe is not visible clearly if the field iris is focused insufficiently.
- 7. Turn the quarter-wave plate rotation ring ① so that the black interference stripe seen at the center of the eyepiece sleeve's field of view, then tighten the clamping knob ②. Ignore the short interference stripes in the surroundings in this adjustment. Since this adjustment renders the field of view dark, observation cannot be started unless the observation method described in the next item is employed. Now the adjustment is complete.
  - Attach the eyepiece and objective again to the microscope frame.
  - With the WI-DICD, remove it and mount the required DIC prism.
  - When an IR cut filter is used, remove it and mount the required filter.

**6 Observation Method**

(Fig. 42)

1. Engage the objective to be used in the light path.
2. When the WI-UCD or U-UCD8 condenser is used, engage the DIC prism matching the objective in the light path by rotating the turret.
3. Place the specimen on the stage and bring the specimen into focus.
  - ⊙The contrast may be improved by stopping down the aperture iris diaphragm to an optimum aperture.
4. Rotate the polarizer dial ① on the filter turret to obtain optimum contrast for the specimen. Tighten the clamping knob ② if required.

## 5-2 Reflected Light Fluorescence Observation

◎ Refer to the instruction manual of your reflected light fluorescence system. If you are using a reflected light illuminator which is not motorized, it is recommended to use the WI-RSH illuminator shutter.

### Illuminator Shutter WI-RSH

◎ The shock during observation can be reduced by using this optional shutter in place of using the shutter built into the BX-URA2 or BX-RFA reflected light illuminator.

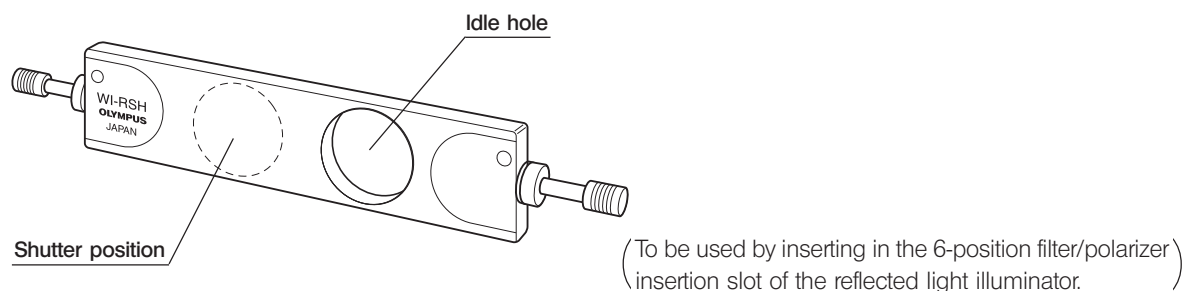

## 5-3 Infrared Light (IR)/Differential Interference Contrast (DIC) Observation

◎ The IR rays (775 or 900 nm) transmit the specimen by about 4 or 5 times more than visible light (550 nm). Therefore, the IR observation is suitable for observing deep areas of a thick brain slice or optic nerve specimen.

### 1 Introduction

1. Since the IR wavelength used is 775 or 900 nm, the TV camera in use should be sensitive in the wavelength used. (Example: C2741-79 CCD camera mfd. by Hamamatsu Photonics)

▲ **The IR light is harmful to your eyes. Avoid visual observation and use the TV monitor whenever possible. Should visual observation be used, mount the IR cut filter (light blue) provided with the filter turret and engage the IR cut filter in the light path.**

2. To reduce the influence of heat on the specimen, stop down the field iris diaphragm of the BX61WI microscope as small as possible. However, the contrast may sometimes be improved by circumscribing the field iris diaphragm with the field of view.

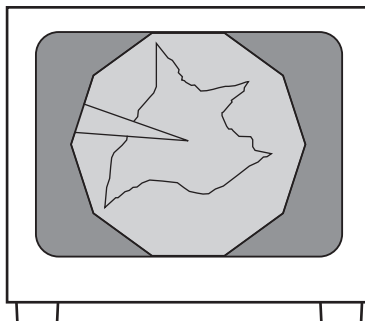

3. To enable IR observation, the following modules should be replaced with those based on the IR specifications.

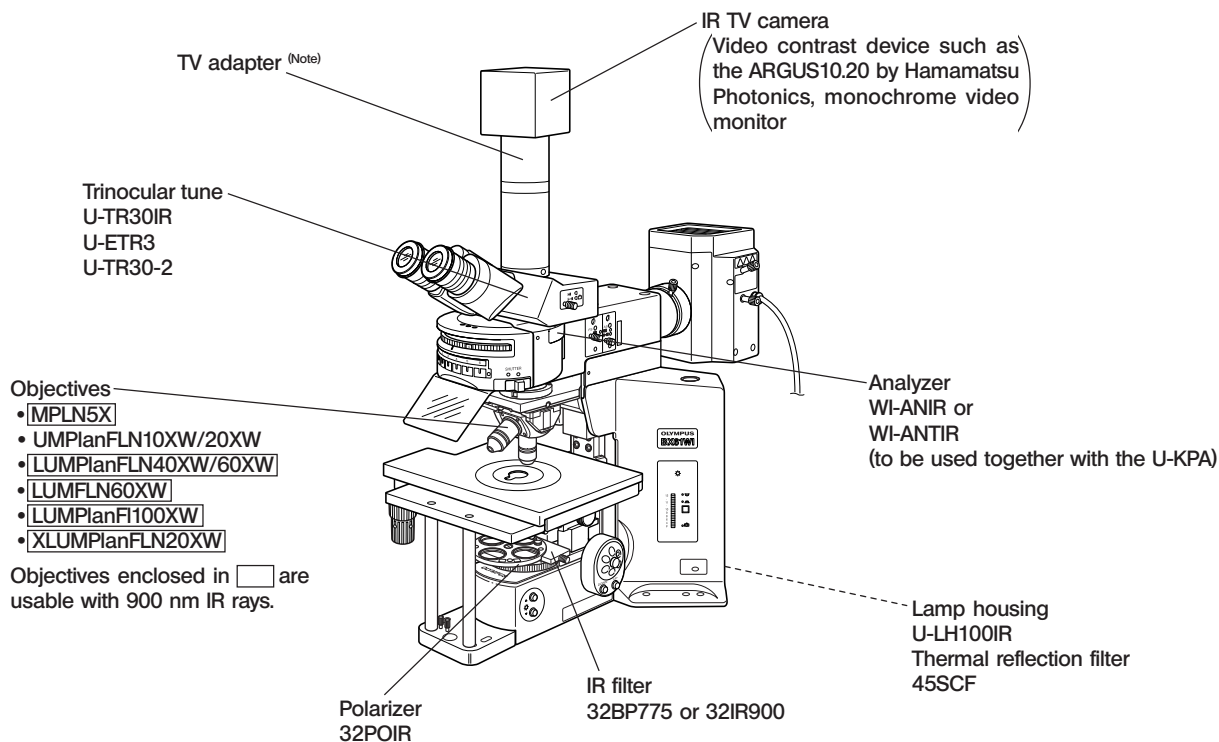

**(Note) Notes for combination of the TV adapter, intermediate attachment and observation tube**

When an observation tube other than the U-TR30IR is used, select the TV adapter by referring to combinations a) to c) below.

★ With IR observation, the combination with the U-PMTVC or U-DPT cannot manifest full performance.

a) Combination for observing a wide field (direct image 1X)

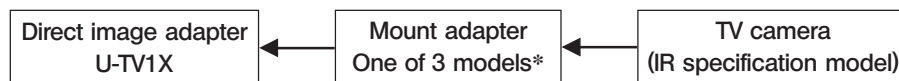

\* The mount adapter should be one of: 1) U-CMAD3 mount adapter; 2) U-BMAD bayonet mount adapter; 3) U-SMAD Sony camera mount adapter.

Note) When the contrast is enhanced rather excessively by an image processor, the central area of the monitored image may be made bright and noticeable.

b) Combination using C-mount adapter IR system (visible light to 1000 nm)

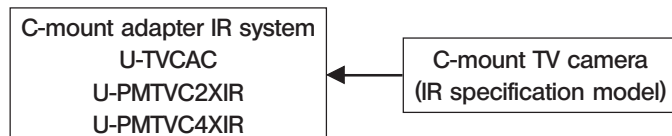

c) Combination using U-CA or U-ECA intermediate tube

One of these intermediate tubes can be used only in combination with the U-ETR3 or U-TR30IR trinocular tube. The TV adapter used in this combination should be one of that used in a) or b).

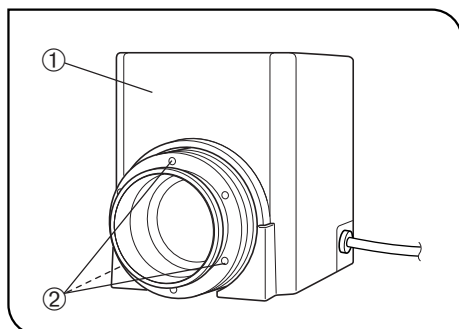

Fig. 43

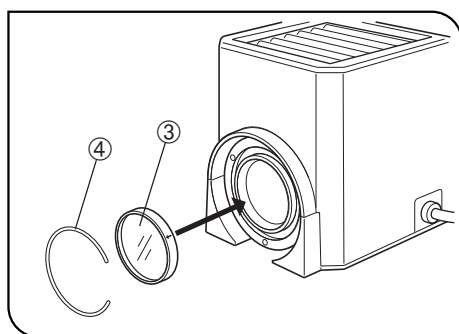

Fig. 44

## 2 Attaching the IR Modules

(Figs. 43 & 44)

### Thermal Reflection Filter 45SCF

1. Remove the collector lens of the U-LH10IR lamp housing ① by loosening the 3 clamping screws ② with an Allen wrench (width across flats of 2.5 mm).

2. While positioning the 45SCF filter ③ so that the arrow on its frame points in the opposite direction of the lamp housing, insert the filter in the lamp housing, and clamp by tightening the ring spring ④ provided with the filter.

3. Attach the collector lens to the original position.

### IR Filter 23BP775 or 32IR900

Ⓞ Be sure to insert the 32BP775 or 32IR900 IR filter in the filter slider below the filter turret. (For the mounting method, see page 15.)

★ If the IR filter is inserted above the polarizer in the filter turret, the polarizer will be burnt.

### Other IR Modules

Also replace other required modules with the IR modules (see page 30).

### 3 DIC Observation Using IR

▲ Since IR light is harmful to your eyes, use the monitor observation whenever possible even in adjustments.

1. First, perform adjustments for DIC observation without using IR.

◎ Do not mount the IR filter and see Section 5-1, "Differential Interference Contrast Observation" on page 24.

#### IMPORTANT

- Focus the field iris diaphragm image (page 21).  
Be sure to perform this adjustment accurately because it determines the visual performance using the IR light.
- With DIC observation using IR, do not stop down the aperture iris diaphragm lever ① but leave the diaphragm open. Since the contrast can be enhanced by the video enhancement function of the CCD camera controller, the diaphragm should be left open here so that the system can manifest full performance.

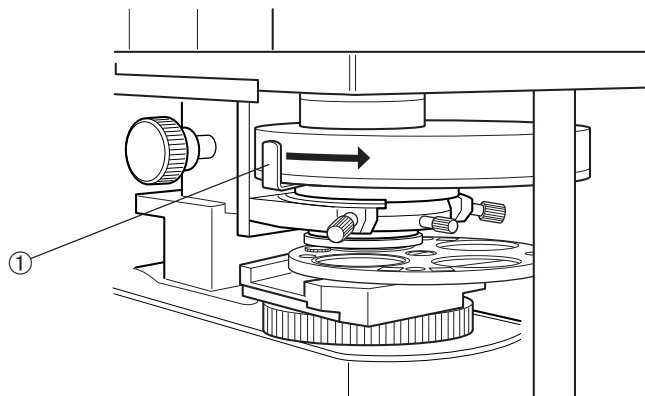

2. Then engage the IR filter (32BP775 or 32IR900) in the light path by pushing in the filter slider.

3. While observing the monitor, perform DIC observation using IR.

a) Turn the condenser turret (other than the WI-DICD) to select the DIC prism matching the objective to be used.

b) Engage the objective to be used in the light path.

★ Penetration of air bubbles inside the front lens of objective will deteriorate the view. To prevent this by removing the bubbles, turn the revolving nosepiece slightly to move the immersed objective to the left and right for a few times.

c) Bring the specimen into focus by moving the objective up and down.

4. Turning the 32POIR polarizer varies the density of the background. Set the polarizer to obtain optimum contrast for the specimen.

## 5-4 Macro Reflected Light Fluorescence Observation

©The macro reflected light fluorescence observation makes possible bright, low-magnification fluorescence observation by combining low-magnification fluorescence mirror units and fluorescence objective.

### 1 Introduction

1. For the low-magnification fluorescence observation, use a low-magnification fluorescence mirror units.  
The increased observation beam diameter of the fluorescence mirror units brightens the fluorescence by about 25%. However, due to the large size of the fluorescence mirror units, they can be mounted only in every other position when the BX-URA2 or BX-RFA reflected fluorescence illuminator is used (a total of 3 units can be mounted on each illuminator).
2. When performing transmitted light brightfield observation using a low-magnification fluorescence objective (2X or 4X), also use the U-SC3 or U-UCD8 swinging condenser. If other condenser is combined, it will not be possible to illuminate the entire field of view.
3. During low-magnification fluorescence observation, objective switching or stage movement, be careful so that the UIS2 (UIS) objective does not interfere with the specimen or culture container.
4. The low-magnification fluorescence objectives have been designed to manifest performances with no-covered dry specimens to specimens located 5 mm below water surface level.  
As a result, with water immersed specimens, the focused positions of these objectives are different from UIS2 (UIS) objectives.
5. To enable macro reflected light fluorescence observation, the following modules should be replaced.

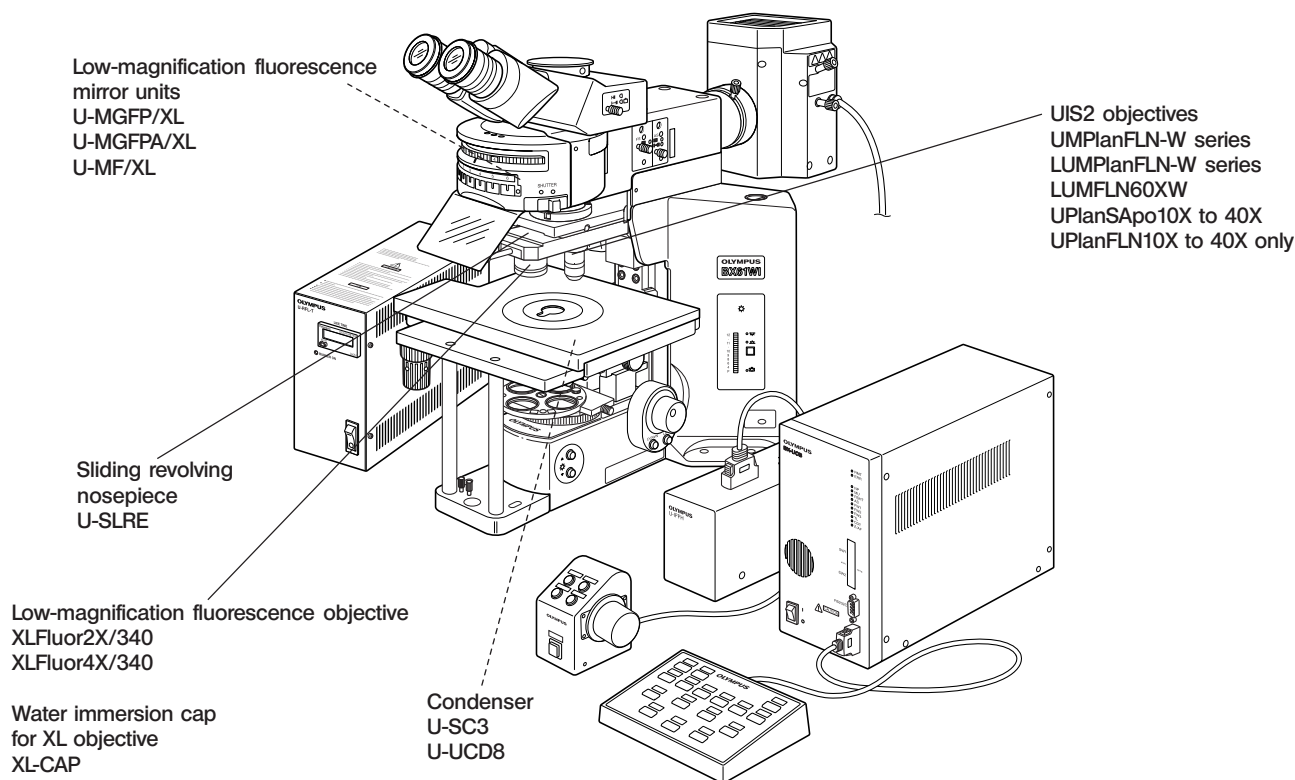

## 2 Attaching the Modules

(Figs. 45 & 46)

### Low-Magnification Fluorescence Mirror Units

- ⊙ Select the suitable mirror units for purpose of observation by referring to page 35.
  - ⊙ If you want to fabricate optional mirror units, see page 35.
  - Mount the mirror units as indicated in the instruction manual of your reflected light fluorescence system.
- Note that mirror units can be mounted only in every other positions.

### Objective

1. Screw a UIS2 objective ② into the position on the deeper side of the U-SLRE sliding revolving nosepiece ①.
2. Screw a XLFluor2X/340 or XLFluor4X/340 low-magnification fluorescence objective ③ into the position on the shallower side of the U-SLRE.

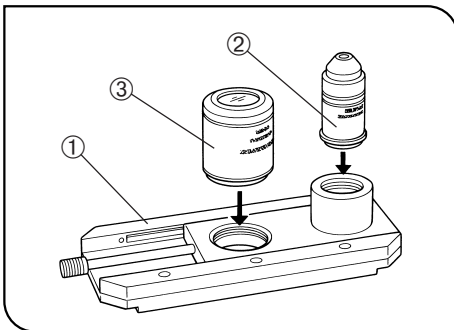

Fig. 45

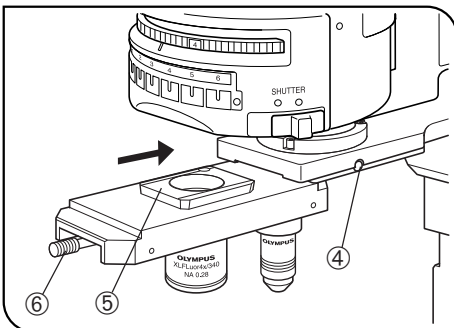

Fig. 46

### Sliding Revolving Nosepiece U-SLRE

1. Raise the revolving nosepiece mount fully.
2. Loosen the revolving nosepiece mount screw ④ on the microscope frame using the Allen screwdriver provided with it.
3. Align the mount dovetail ⑤ of the sliding revolving nosepiece with the revolving nosepiece mount dovetail and gently slide the sliding revolving nosepiece all the way in from the front as shown in the figure.
4. Clamp the revolving nosepiece by tightening the revolving nosepiece mount screw ④.

### Swinging Condenser U-SC3/U-UCD8

- ★ Attach the U-SC3 with the top lens swung out.
- The condenser top lens should be swung out when using the 2X or 4X objective.

### 3 Filter Characteristics of Fluorescence Mirror Units

Excitation Method	Mirror Unit	Dichroic Mirror	Excitation Filter	Barrier Filter	Application
IB	U-MGFP/XL	DM505	BP460-490	BA510IF	For EGFP, S65T, RSGFP. (U-MGFP/XL is for fluorochrome separation.)
	U-MGFPA/XL			BA510-550	

1. IB excitation (wide bandwidth) **U-MGFP/XL**

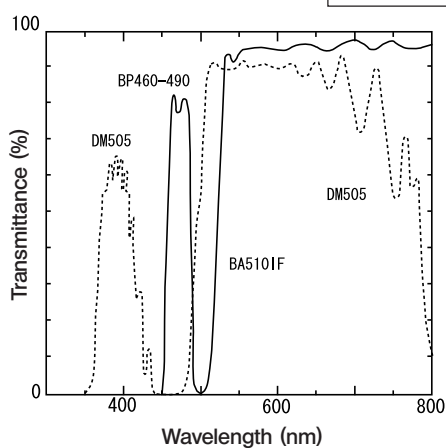

2. IB excitation (wide bandwidth) **U-MGFPA/XL**

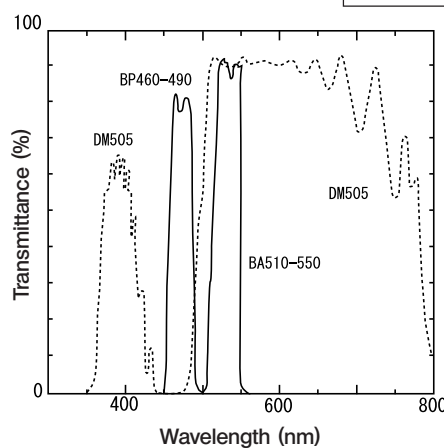

### 4 Fabricating Optional Mirror Units

◎An optional mirror unit can be fabricated by attaching the custom-order barrier filter, excitation filter and dichroic mirror to the U-MF/XL

#### Dimension Conditions of Optical Components of Mirror Unit

- Barrier filter:  $\phi 32^{+0.1/-0.2}$  mm, max. thickness 4 mm
- Excitation filter:  $\phi 25^{+0.1/-0.2}$  mm, max. thickness 6 mm
- Dichroic mirror: See figure on the right.

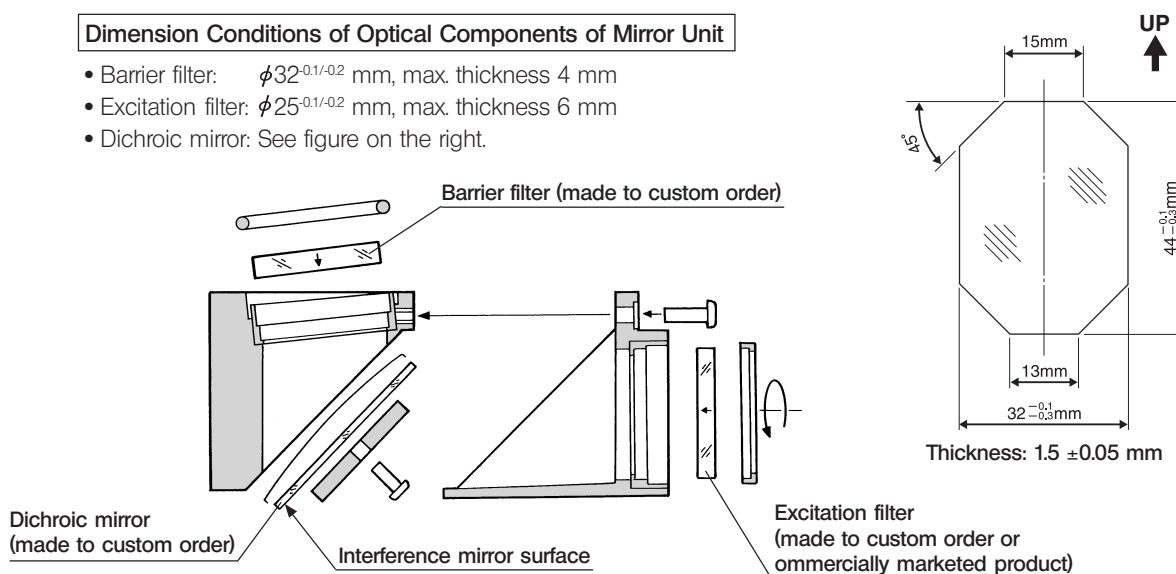

★ When replacing the dichroic mirror, take special care not to stain it by leaving fingerprints, etc.

# 6 TROUBLESHOOTING GUIDE

Under certain conditions, performance of the microscope may be adversely affected by factors other than defects. If problems occur, please review the following list and take remedial action as needed.

If you cannot solve the problem after checking the entire list, please contact your local Olympus representative for assistance.

Problem	Cause	Remedy	Page
<b>1. Optical System</b>			
a) The bulb does not light.	The power cord of the BX-UCB is unplugged.	Plug the power cord into a power outlet.	-
	The main switch of the BX-UCB is not ON.	Set the main switch to " I " (ON).	-
	The Lamp ON/OFF switch on the BX61WI is not ON.	Set the Lamp ON/OFF switch to ON.	-
	The bulb is burnt out.	Replace the bulb.	48
	The transmitted/ reflected light switch is set to reflected light ( ㄣ ).	Set the switch so that the LED indicating transmitted light ( ㄥ ) lights.	14
b) The bulb lights but the field of view is dark.	The aperture or field iris diaphragm is opened in sufficiently.	Open the aperture and field iris diaphragms.	21/22
	The condenser is in too low a position.	Adjust the condenser height.	21
	The light path selector knob of is set to position ㊦.	Set the light path selector knob to position ㊤ or ㊥.	20
c) Field of view is obscured or not evenly illuminated.	The light path selector knob is in an intermediate position.	Set the light path selector knob to a click position according to the purpose..	20
	The revolving nosepiece is not in a click position.	Set it in a click position.	18
	The condenser is installed incorrectly.	Re-install it.	47
	The revolving nosepiece is installed incorrectly.	Secure it by pushing in the sliding dovetail all the way until the stopper.	45
	The filter turret or filter slider is incorrectly engaged in the light path.	Engage them correctly in the light path.	15
	The frost insertion/removal lever is set to an intermediate position or OUT.	Engage the frost filter correctly in the light path.	16
	An objective outside the illumination range of the condenser is in use.	Use an appropriate condenser for the purpose.	9
	The condenser is not centered.	Adjust the centering.	21
	The field iris diaphragm is closed too much.	Open it until it circumscribes the field of view.	21
	The lamp bulb is not installed correctly.	Push the halogen bulb terminals all the way into stop position.	48
d) Dirt or dust is visible in the field of view.	Dirt/dust on eyepieces.	Clean thoroughly.	3
	Dirt/dust on condenser top lens.		
	Dirt/dust on specimen.		

Problem	Cause	Remedy	Page
e) Visibility of observed image is poor. <ul style="list-style-type: none"> <li>• Image is not sharp.</li> <li>• Contrast is poor.</li> <li>• Details are poorly visible</li> </ul>	The objective in use is not designed for UIS2 (UIS) series.	Replace with a specified objective for UIS2 (UIS) series.	41
	The condenser is set to too low a position.	Adjust the condenser height.	21
	The aperture iris diaphragm is closed too much.	Open it sufficiently.	22
	The objective is engaged incorrectly in the light path	Make sure that revolving nosepiece clicks into place correctly.	18
	Air in the objective front lens.	Remove the air.	32
	The specimen such as a brain slice is fixed poorly.	Fix it correctly.	-
	Bubbles attached to the objective front lens.	Remove the bubbles.	32
	Too small quantity of solution in the petri dish.	Supply sufficient solution in the petri dish.	-
	The petri dish is tilted.	Place the petri dish correctly on the stage.	17
	Dirt/dust on the objective front lens.	Clean it thoroughly using neutral detergent.	3
	Dust/dirt on the condenser.	Clean it thoroughly.	3
f) One side of image is blurred.	The revolving nosepiece is installed incorrectly.	Secure it by pushing in the sliding dovetail all the way until the stopper.	45
	The objective is engaged incorrectly in the light path.	Make sure that revolving nosepiece clicks into place correctly.	18
	The objective is placed incorrectly (may be loose) in the revolving nosepiece position.	Insert the objective all the way into the revolving nosepiece position until it is stopped.	-
	The stage center plate is tilted.	Correct the tilt.	-
g) Image appears to waver.	The revolving nosepiece is installed incorrectly.	Secure it by pushing in the sliding dovetail all the way until the stopper.	45
	The objective is engaged incorrectly in the light path.	Make sure that revolving nosepiece clicks into place correctly.	18
	The objective is placed incorrectly (may be loose) in the revolving nosepiece position.	Insert the objective all the way into the revolving nosepiece position until it is stopped.	-
	The condenser is centered incorrectly.	Center it correctly.	21
h) Focusing is lost when the objective is switched (with the WI-SRE3).	The confocality is adjusted incorrectly.	Adjust it correctly.	45/46
i) The field of view becomes only slightly brighter when the voltage is raised.	The condenser is centered incorrectly.	Center it correctly.	21
	The condenser is in too low a position.	Adjust the condenser height.	21

Problem	Cause	Remedy	Page
<b>2. Electrical System</b>			
a) The bulb intermittently lights and goes out.	The bulb is nearly burnt out.	Replace the bulb.	48
	A cord or connector is not properly connected.	Connect cords and plugs securely.	-
b) The lamp bulb burns out soon after lighting.	The bulb in use is not the specified lamp.	Replace with a standard bulb.	48
c) The brightness cannot be varied with the light intensity control.	No lamp bulb is installed.	Attach a lamp bulb.	48
	The lamp bulb is burnt out.	Replace the lamp bulb.	48
	The lamp housing output connector is unplugged.	Plug the lamp housing output connector.	-
d) The brightness cannot be varied with the light intensity control.	The lamp bulb is burnt out.	Replace the lamp bulb.	48
e) The BX-UCB's Z/AF gets into the error status immediately after the control box is turned on, and no operation is possible.	Emergency stop is activated because the focus adjustment knob is operated during initialization.	Turn the control box off and then on again to perform the initialization operation.	1
<b>3. Observation Tube</b>			
a) The field of view of one eye does not match that of the other.	The interpupillary distance is incorrect.	Adjust interpupillary distance.	19
	Incorrect diopter adjustment.	Adjust diopter.	19
	Different eyepieces are used on the left and right.	Change one eyepiece to match the other so that both sides are of the same type.	-
	You are not accustomed to parallel optical axis.	When looking into eyepieces, do not stare at image from the beginning but see the overall field of view. It is sometimes recommended to turn your eyes away from eyepieces, look far off and look into eyepieces again.	-
<b>4. Stage</b>			
a) Stage travel in the horizontal (X-axis) direction stops in the middle.	The specimen is set incorrectly.	Place the specimen correctly.	17
b) The X-axis and/or Y-axis stage knobs are too light or too heavy to rotate.	The X-axis and/or Y-axis rotation tension is not adjusted properly.	Adjust the knobs to optimum tension.	17

# 7 SPECIFICATIONS

Item	Specification			
1. Optical system	UIS2 (UIS) (Universal Infinity System) optical system (Infinity correction)			
2. Illumination system	Transmitted Kohler illumination built in (FN 22) 12 V, 100 W long-life halogen bulb (pre-centered) 12V100WHAL-L (PHILIPS 7724) or 12 V, 50 W long-life halogen bulb (precentered) 12V50WHAL-L (LIFE JC) Average life time: Approximately 2000 hr. when used as directed. Light intensity voltage range: Below 2.0 up to 12.0 V DC (continuously variable). With a light intensity preset switch (Voltage variation range: Below 2.0 up to 12.0 V DC) External power supply rating (BX-UCB): AC 100-120/220-240 V ~ , 50/60 Hz, 3.5/1.5 A Power consumption: 50 to 300 W (variable depending on the number of connected modules.) (Example – About 200 W with the 100 W halogen bulb and motorized focusing)			
3. Focusing system	Drive system: Motorized focusing using a stepping motor and ball screw. Revolving nosepiece height movement by cross-roller guide Finest adjustment scale: 1 μmm (fine adjustment sensitivity of 1 μm) Resolution: 0.01 μm Maximum stage speed: 3 mm/sec. Stroke per rotation: 0.1 mm (fine), 1 mm (coarse) Full stroke range: 25 mm			
4. Revolving nosepiece	Model	WI-SRE3 Swinging Revolving Nosepiece	U-SLRE Sliding Revolving Nosepiece	WI-SNPXLU2 Single-Position Revolving Nosepiece
	Attachable modules	DIC prisms mountable	————	DIC prisms mountable
5. Observation tube	Model	U-TR30-2 Widefield Trinocular		U-ETR3 Widefield, Upright-Image Trinocular
	Field number	22		
	Tube tilting	30°		25°
	Interpupillary distance adjustment	50 mm to 76 mm		
	Light path selection	3-step switching: ①Binocular 100% ②Binocular 20% TV/Photo 80% ③TV/photo 100%		2-step switching: ①Binocular 100% ②TV/photo 100%
6. Stage	Model	IX-SVL2 Stage with Bottom-Side Knobs		
	X/Y movement mechanism	X-axis/Y-axis knob tension adjustable Movement range: 50 mm (X-axis) x 43 mm (Y-axis)		
7. Long-WD condenser	Model	WI-UCD Universal Condenser	WI-DICD DIC Condenser	WI-OBCD Oblique Condenser
	NA	0.8		
	Working distance	5.7 mm		
	Aperture iris	Variable aperture iris diaphragm		
	Turret	4-position		————
	DIC prisms	Max 4 prisms can be mounted.	Only 1 prism can be mounted.	————
	Other	Quarter-wave plate built in		Variable oblique iris built in

Item	Specification
8. Operating environment	<ul style="list-style-type: none"><li>• Indoor use</li><li>• Altitude: Max. 2000 m</li><li>• Ambient temperature: 10° to 40°C (50°F to 104°F)</li><li>• Maximum relative humidity: 80% for temperatures up to 31°C (88°F), decreasing linearly through 70% at 34°C (93°F), 60% at 37°C (99°F), to 50% relative humidity at 40°C (104°F)</li><li>• Supply voltage fluctuations: ±10%</li><li>• Pollution degree: 2 (in accordance with IEC60664)</li><li>• Installation (overvoltage) category: II (in accordance with IEC60664)</li></ul>

# 8 OPTICAL CHARACTERISTICS

— **UIS series objectives not listed here can also be combined with this microscope.** —

The following table shows the optical characteristics of combinations of eyepieces and objectives. The figure on the right shows the performance data engraved on the objectives.

**NOTE**

Refer to the latest catalogue or consult your local Olympus representative for the updated information on the eyepieces and objectives that can be combined with this microscope.

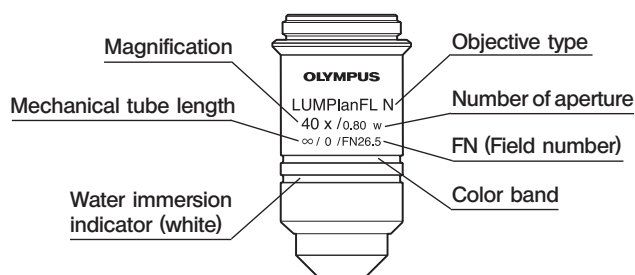

Optical character  Objective		Power	N.A.	W.D. (mm)	Resolution (μm)	Eyepiece			Remark
						WHN10X (FN22)			
						Total Power	Focal Depth (μm)	Actual Field	
UIS2 series	MPLN Plan Achromat (FN 22)	5X	0.1	20.0	3.36	50X	98	φ 4.4	Water immersion impossible
	UMPlanFLN-W Water Immersion Universal Plan Semi-Apochromat (FN 26.5)	10XW 20XW	0.30 0.50	3.50 3.50	1.10 0.67	100X 200X	20 6.1	φ 2.2 φ 1.1	
	LUMPlanFLN-W Long-WD Water Immersion Universal Plan Semi-Apochromat (FN 26.5)	40XW* 60XW*	0.80 1.00	3.30 2.00	0.42 0.34	400X 600X	2.0 1.3	φ 0.55 φ 0.37	*Usable with IR 900 nm.
	LUMFLN-W Long-WD Water Immersion Universal Semi-Apochromat (FN 26.5)	60XW*	1.10	1.50	0.31	600X	0.7	φ 0.37	Correction collar
	XLUMPlanFLN-W High-NA Water Immersion (FN 22)	20XW*	1.00	2.00	0.34	200X	0.83	φ 1.1	
UIS series	LUMPlanFI-W Long-WD Water Immersion Universal Plan Semi-Apochromat (FN 26.5)	100XW*	1.00	1.50	0.34	1000X	0.83	φ 0.22	
	XLFluor Low-Power Fluorescence (FN 22)	2X/340 4X/340	0.14 0.28	20.0 28.4	2.40 1.20	20X 40X	132 33.0	φ 11 φ 5.5	Water immersion impossible Water immersion impossible

**NOTE**

Be sure to clean the extremity of water immersion objective using neutral detergent. If the extremity is left without cleaning, contamination remains and the objective performance will deteriorate.

## 9-1 Assembly Diagram

The diagram below shows the sequence of assembly of the modules. The numbers indicate the order of assembly. The module numbers shown in the following diagram are merely the typical examples. For the modules with which the module numbers are not given, please consult your Olympus representative or the latest catalogues.

★ When assembling the microscope, make sure that all parts are free of dust and dirt, and avoid scratching any parts or touching glass surfaces.

Assembly steps enclosed in **■** will be detailed on the subsequent pages.

◎ All assembly operations are possible by using the Allen screwdriver (  ) provided with the microscope. However, the reflected light illuminator should be attached using the Allen wrench provided with the illuminator to clamp the internal screws. (To assure the performance, please have your dealer assemble the illuminator.)

The filter turret and cross stage are to be clamped respectively using the special tools provided with them.

(Note) For the detailed assembly procedures of the reflected light fluorescence system, the BX-UCB control box and the TH4 power supply unit, refer to their instruction manuals.

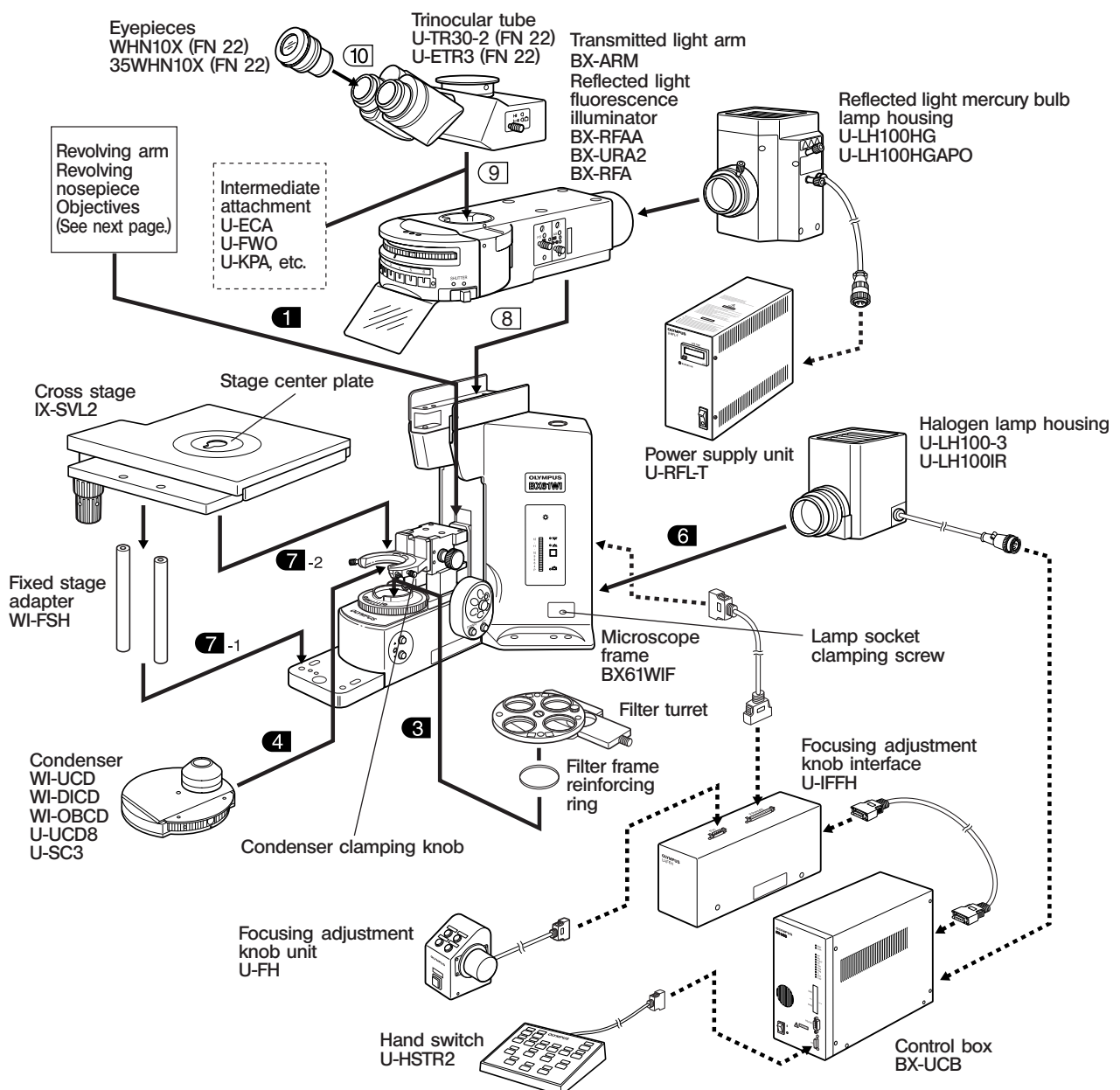

**Revolving Arm, Revolving Nosepiece, Objectives**

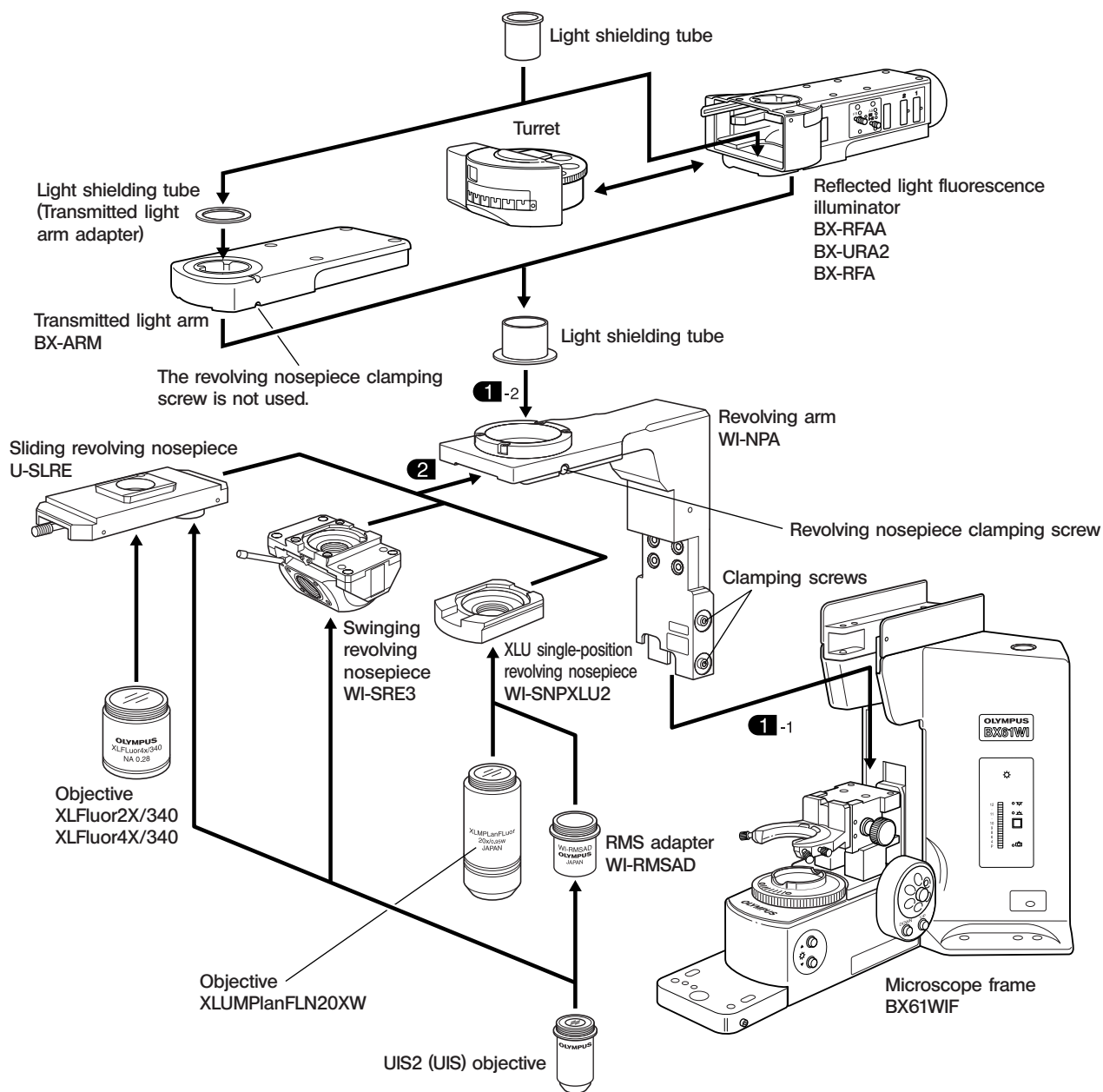

**5** Waterproof covers (x 3): Biorepellent polyethylene

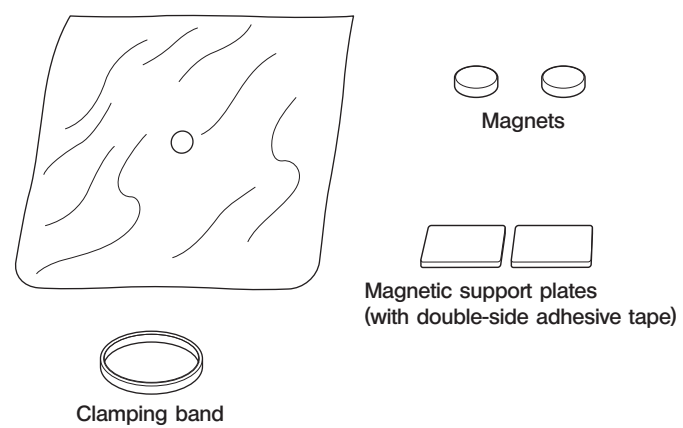

## 9-2 Detailed Assembly Procedures

★ **Be always sure to use the U-ZPCB(T2) Z board which is designed to be compatible with the BX61WI.**

The following phenomena will occur with the U-ZPCB even though the correct setup is performed.

- The rotation direction of the focus adjustment knob is opposite to the actual movement direction of the objectives.
- Initialization may not be possible depending on the position of the focusing block. (The microscope may not start up.)

### Setting Up and Mounting the Z Board

Ⓞ The on-board DIP switches on the Z board have been designed for use with the BX61 or BX62 microscope at the factory (i.e. all of the S1, S2 and S3 switches at the OFF positions).

Change the setup of the DIP switches to enable the use of the Z board with the BX61WI.

### Changing the On-Board DIP Switch Setting (Fig. 47)

★ **Set all other switches than those listed below to the OFF positions.**

- **S2** Set No. 2 and No. 3 to ON.
- **S3** Set No. 2, No. 4 and No. 5 to ON.

★ **If the setting is not correct, the objective may lower and hit the specimen during initialization.**

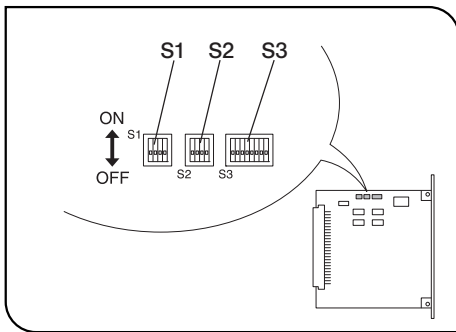

Fig. 47

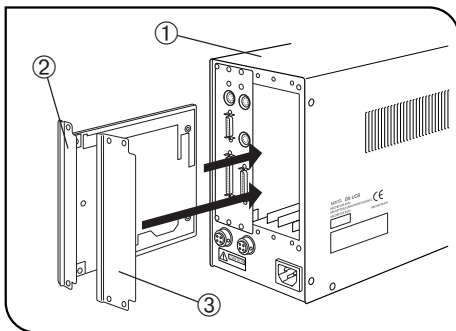

Fig. 48

### Mounting the Z Board (Fig. 48)

Ⓞ Set the main switch of the BX-UCB control box ① to "○" (OFF) before mounting the Z board.

1. Loosen the 6 knobs clamping the 2 option slot covers on the rear of the BX-UCB and remove the knobs and covers.
2. Align the connector of the Z board ② with that inside the BX-UCB and insert the board along the board rails.
3. Clamp the Z board ② using the clamping knobs removed above. Attach the other cover ③ in the same way.

Ⓞ Retain the cover removed for mounting the Z board carefully.

ⓄWhen performing observation on a desktop, attach the provided rubber feet (x 4) to the front (x 2) and rear (x 2) parts on the bottom of the base. Note that the rubber feet are not necessary when installing the microscope on an anti-vibration bench.

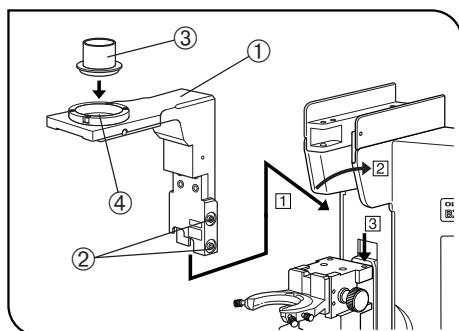

Fig. 49

## 1 Attaching the Revolving Arm (Fig. 49)

1. Loosen the 2 clamping screws ② of the revolving arm ① using an Allen screwdriver and fit the arm into the mount dovetail on the microscope frame along the direction of arrow from ① to ③.
2. Push the revolving arm all the way until it is stopped, then tighten the clamping screws.
3. Screw in the light shielding tube ③ into the retaining screw ④.

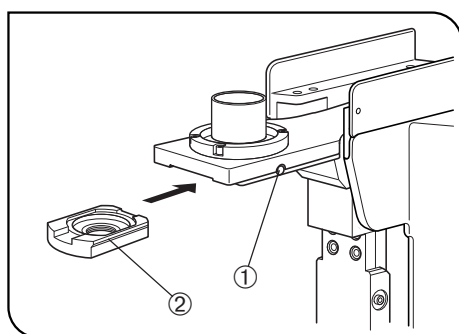

Fig. 50

## 2 Attaching the Revolving Nosepiece (Fig. 50)

ⓄThe attaching procedure is common for the U-SLRE, WI-SRE3 and WI-SNPXLU2 revolving nosepieces, except that the WI-SNPXLU2 ② should be inserted so that the round end comes on the front.

**CAUTION** In DIC observation using the WI-SRE3 or WI-SNPXLU2 revolving nosepiece, attach the DIC prisms before attaching the revolving nosepiece (see page 25).

1. Loosen the revolving nosepiece clamping screw ① using an Allen screwdriver, and slide in the revolving nosepiece ② along the mount dovetail.
2. Push the revolving nosepiece all the way in and tighten the clamping screw.

### WI-SRE3 Only

ⓄWhen the microscope has been assembled, the confocality adjustment and centering of the two objectives can be performed.

### Adjusting the Confocality of Objective (Figs. 51 & 52)

ⓄTo maintain the accurate focusing even after the objective is switched, the height of the objective with the higher focal point is corrected by attaching a washer.

Nine washers with three kinds of thickness (10, 30 and 50 μm), three per kind, are provided with the microscope.

1. Engage the objective on the front side in the light path. Use the coarse/fine adjustment knobs on the front side to adjust focusing.

ⓄAccurate focus cannot be achieved if the coarse/fine adjustment knobs on the back side are used.

2. To find the confocality difference, read the scale indication of the fine adjustment dial ② (1 scale graduation: 1 μm).

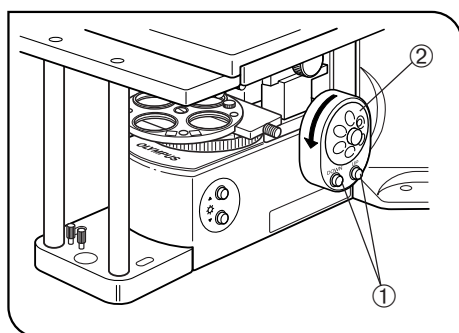

Fig. 51

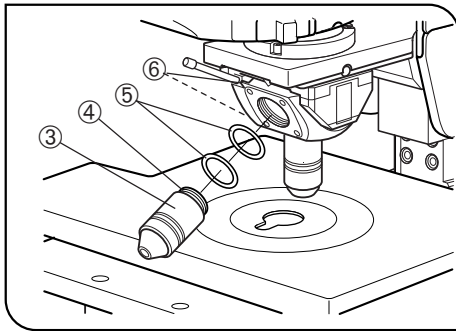

Fig. 52

3. Engage the objective on the back side in the light path.  
Adjust focusing, read the scale indication of the fine adjustment knob and obtain the difference from the value read in step 2 above.
  4. The objective to use the washer is determined by the rotation direction of the fine adjustment dial ②. (Fig. 51)
    - Direction of the arrow: Objective on the front side.
    - Opposite direction to the arrow: Objective on the back side.
  5. Remove the objective ③, fit the washer ⑤ with the required thickness on the screw ④, and then attach the objective again.
  6. Switch the objective and confirm that confocality is implemented.
- ★ The confocality adjustment may sometimes be unable to implement perfect confocality.

#### Centering the Objective (Fig. 52)

- Ⓞ The centering mechanism is provided only for the objective on the front side.
1. Adjust focusing using the objective on the front side, then move the target region in the specimen on the center of the field.
  2. Switch the objective to that on the front side.
  3. Insert the centering knobs into the threaded holes ⑥ and turn them to move the target in the objective on the center.
- Ⓞ After completing centering, store the centering knobs in the accommodation position on the front side of the microscope (page 5) so as not to lose them.

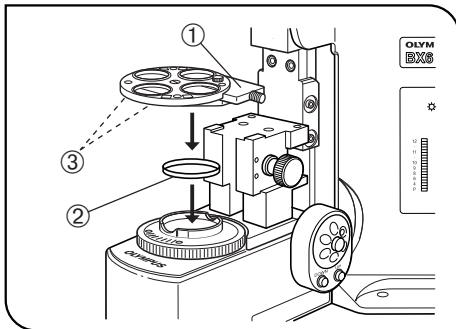

Fig. 53

### 3 Attaching the Filter Turret

(Fig. 53)

- Ⓞ When a bridge stage or a stage with similar design is used, the filter slider ① can be attached so that it faces toward the front of the microscope.
1. Drop in the filter frame reinforcing ring ② into the filter holder on the microscope frame.
  2. Loosen the 2 filter turret clamping screws ③ using the provided Allen wrench.
  3. Fit the filter turret on the filter holder and tighten the clamping screws ③ lightly to a degree at which the filter turret will not rotate.
  4. For the insertion of the polarizer and filters, see page 15.

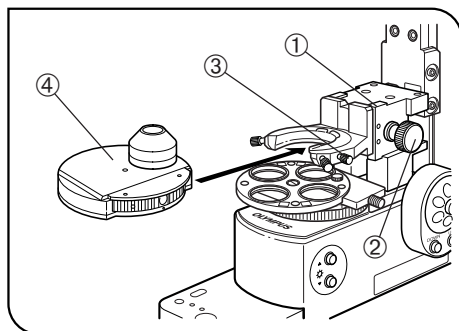

Fig. 54

#### 4 Attaching the Condenser (Fig. 54)

★ When attaching a condenser other than the WI-UCD, remove the upper limit stopper screw ① of the condenser holder with an Allen screwdriver.

Ⓞ In DIC observation, attach the DIC prism (for condenser) before attaching the condenser onto the microscope frame (page 25). However, with the WI-DICD condenser, the DIC prism should be attached after adjusting the polarizer position.

1. Rotate the condenser height adjustment knob ② to raise the condenser holder to an optimum height.
2. Fully loosen the condenser clamping knob ③.
3. Slide in the condenser ④ from the front along the mount dovetail all the way until it is stopped.

★ When the microscope frame has a positioning pin on the rear position of the condenser, align the condenser with the groove on the condenser holder.

4. Tighten the condenser clamping knob and lower the condenser holder to the lowest limit position.

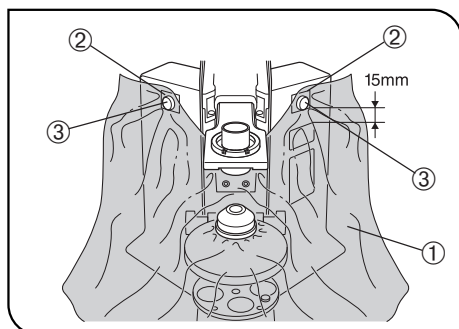

Fig. 55

#### 5 Attaching the Waterproof Cover (Fig. 55)

Ⓞ Attach the waterproof cover onto the condenser if required.

The waterproof cover is applicable only to the WI-UCD, WI-DICD and WI-OBCD condensers.

1. Fit the hole of the waterproof cover ① in the extremity of the condenser and clamp with the clamping band.

#### CAUTION

In DIC observation, the condenser has to be removed and attached during adjustments. Therefore, in this case, do not attach the clamping band but just fit the hole of the waterproof cover in the extremity of the condenser and attach the clamping band after completing the adjustments.

2. To hold the skirt of the waterproof cover, attach the pieces of double-sided adhesive tape on the magnetic support plates ② on both side of the microscope frame and press the tape firmly against the microscope frame.

Ⓞ The magnetic support plates ② are most effective when they are attached symmetrically at positions by about 15 mm above the **BX61WI** indication.

3. Fix the waterproof cover using the magnets ③.

Ⓞ When the cross stage is used, the stage mounting screw holes (x 4 on the front and rear) are hidden by the waterproof cover. However, this does not pose problem because the screws can later be attached by passing through the waterproof cover.

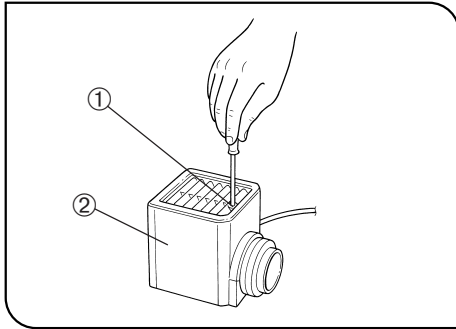

Fig. 56

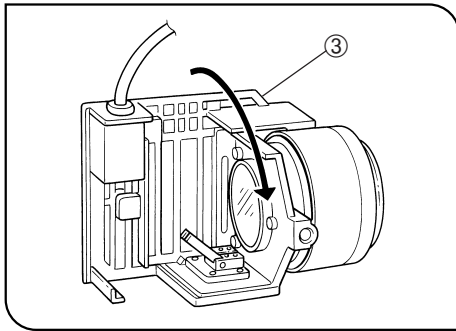

Fig. 57

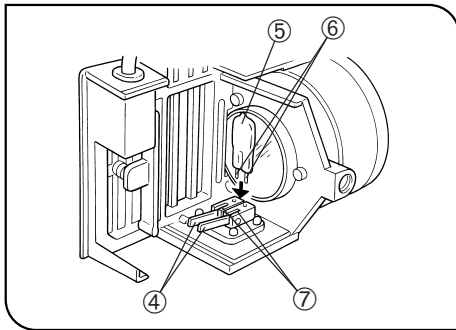

Fig. 58

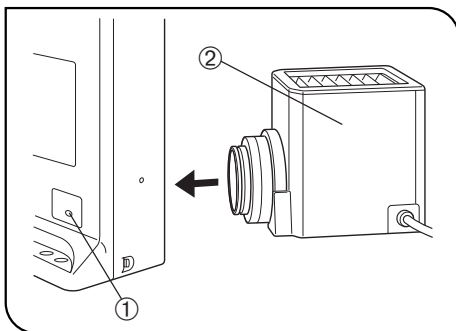

Fig. 59

## 6 Attaching the Halogen Lamp Housing (Figs. 56 to 59)

### Attaching the Halogen Bulb

Ⓞ The applicable lamp bulb model is the 12V100WHAL-L (PHILIPS 7724) or the 12V50WHAL-L (LIFE JC).

1. Fully loosen the clamping screw ① at the top of the lamp housing using the Allen screwdriver provided with the microscope frame.
  2. Remove the lamp housing ② by lifting it up.
  3. Tilt the bulb socket ③ by 90° in the direction of the arrow.
  4. While pushing down the bulb clamping lever ④ down, hold the halogen bulb ⑤ with gloves or a piece of gauze, insert the bulb pins ⑥ straight and fully into the pin sections ⑦ on the lamp socket.
- Then return the lamp clamping lever gently back to the original position to clamp the bulb.

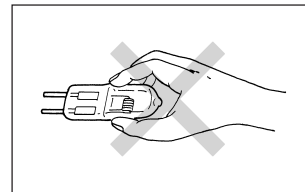

▲ To prevent reduced bulb life or cracking, do not touch the bulb with bare hands. If fingerprints are accidentally left on the bulb, wipe the bulb with a soft cloth.

5. Fit the lamp housing from up and tighten the clamping screw ① by applying downward pressure. (Fig. 56)

### ▲ Caution for Bulb Replacement During or Right after Use

The bulb, lamp housing and areas near these will be extremely hot during and right after use.

Set the main switch to "O" (OFF), disconnect the power cord from the wall outlet, then allow the old bulb and lamp housing to cool before replacing the bulb with a new of the designated type.

### Attaching the Halogen Lamp Housing (Fig. 59)

1. Loosen the bulb socket clamping screw ① using the Allen screwdriver.
2. Push in the halogen lamp housing ② with bulb and tighten the clamping screw ①.

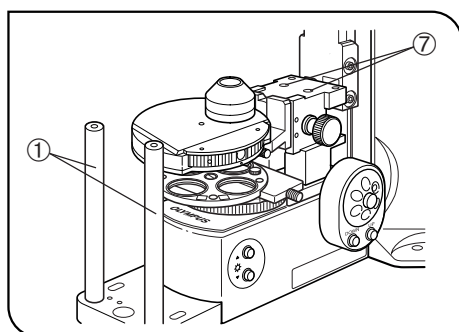

Fig. 60

## 7 Attaching the Cross Stage (Figs. 60 & 61)

Ⓞ When using a WI-XYX bridge stage, attach it by referring to its instruction manual.

1. Align the two WI-FSH fixed stage adapters ① with the front of the microscope frame and clamp the adapters by tightening the hex-socket screws from the bottom side using the Allen wrench provided with the microscope frame.
2. Lower the condenser, align the mounting holes ③ and ⑤ of the IX-SVL2 cross stage ② with the mounting screw holes ④ and ⑥, and clamp the cross stage by tightening the hex-socket screws with the Allen wrench provided with the microscope frame.

Ⓞ When the waterproof cover is used, attach hex-socket screws to the screw holes ④ and ⑥ by passing through the waterproof cover.

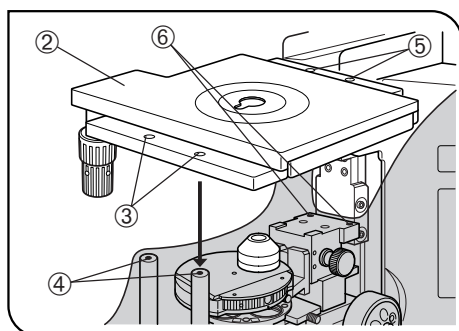

Fig. 61

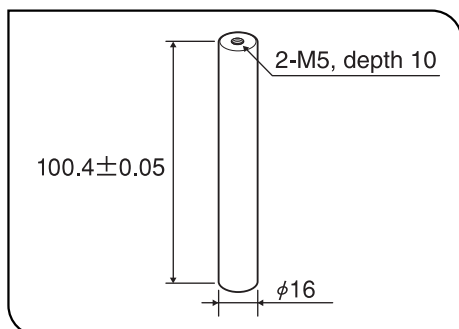

Fig. 62

### Lowering the Stage Height

When no condenser is used, the stage height can be lowered by 50 mm by loosening the 2 holder clamping screws (7 in Fig. 60) and removing the condenser holder.

In this case, however, the length of the WI-FSH fixed stage adapter becomes excessive. To deal with this, order custom fabrication of two support pillars as shown in Fig. 62 or fabricate them by yourself.

# 10 LAMP HOUSING INSPECTION SHEET

- Study the instruction manual for the lamp housing before inspection.
- For safe use of the lamp housing, we recommend performing the following inspection periodically (every time you replace the lamp bulb and at least every 6 months).
- The table below identifies the check items to be observed. Put (X) if not applicable or (√) if applicable.
- If there is any (√) mark noted, immediately stop use of the product, and contact Olympus for detailed inspections or replace the lamp housing.
- If you detect an abnormality other than that listed below or with other Olympus product, also stop the use of the product and contact Olympus for detailed inspections.
- Note that the service, replacement and detailed inspections are charged after expiration of the warranty period.

If you have any questions, please contact Olympus.

Check items	Check results (Date)			
	/	/	/	/
1. More than 8 years have passed since original purchase or the total power ON time has exceeded 20,000 hours.				
2. Lamp does not light sometimes even though the main switch is set to on. (Except discharge burners* <sup>1</sup> .)				
3. Illumination flickers when you move the lamp cable or lamp housing.				
4. Lamp cable is unusually hot to the touch.				
5. Scorching or burning odor is produced during use.				
6. Illumination still flickers after replacement with a new lamp bulb. (Except discharge burners* <sup>1</sup> .)				
7. Deformation, backlash, or looseness, etc. when you assemble the lamp housing. (Impossibility of removing the top section of lamp housing when you attempt to replace the lamp bulb, etc.)				
8. Extreme discoloration of the lamp housing connection terminal or lamp socket. Uneven discoloration of the left and right sections of these parts. (Except discharge burners* <sup>1</sup> .)				
9. Discoloration, deformation or cracking of the lamp housing.				
10. Melting, crack, deformation or solidification of the lamp cable or a wiring part.				
11. Increased frequency of servicing compared to similar devices put into use at the same time as the lamp housing.				

\* When the Check Result columns become insufficient, copy this sheet.

\*<sup>1</sup> Discharge burners: Mercury burner / Xenon burner / Metall halide burner



# **OLYMPUS®**

---



**OLYMPUS CORPORATION**

Shinjuku Monolith, 3-1, Nishi Shinjuku 2-chome, Shinjuku-ku, Tokyo, Japan



**OLYMPUS EUROPA HOLDING GMBH**

Wendenstraße 14-18, 20097 Hamburg, Germany

**OLYMPUS AMERICA INC.**

3500 Corporate Parkway, P.O. Box 610, Center Valley, PA 18034-0610, U.S.A.

**OLYMPUS SURGICAL & INDUSTRIAL AMERICA INC.**

One Corporate Drive, Orangeburg, NY 10962, U.S.A.

**OLYMPUS SINGAPORE PTE LTD.**

491B River Valley Road, #12-01/04 Valley Point Office Tower, Singapore 248373

**OLYMPUS AUSTRALIA PTY. LTD.**

31 Gilby Road, Mount Waverley, VIC., 3149, Australia

**OLYMPUS LATIN AMERICA, INC.**

5301 Blue Lagoon Drive, Suite 290 Miami, FL 33126, U.S.A.

