

OLYMPUS®

INSTRUCTIONS

DP73

MICROSCOPE DIGITAL CAMERA

This instruction manual is for the Olympus Microscope Digital Camera Model DP73. To ensure the safety, obtain optimum performance and familiarize yourself fully with the use of this camera, we recommend that you study this manual thoroughly before operating the camera.

For image operations including recording, editing and saving, please refer to the online manual for the cellSens / OLYMPUS Stream Software.

Retain this instruction manual in an easily accessible place near the work desk for future reference.

AX8080



This device complies with the requirements of both directive 2004/108/EC concerning electromagnetic compatibility and directive 2006/95/EC concerning low voltage.



In accordance with European Directive 2002/96/EC on Waste Electrical and Electronic Equipment, this symbol indicates that the product must not be disposed of as unsorted municipal waste, but should be collected separately.

Refer to your local Olympus distributor in EU for return and/or collection systems available in your country.

NOTE: This equipment has been tested and found to comply with the limits for a Class A digital device, pursuant to Part 15 of the FCC Rules. These limits are designed to provide reasonable protection against harmful interference when the equipment is operated in a commercial environment. This equipment generates, uses, and can radiate radio frequency energy and, if not installed and used in accordance with the instruction manual, may cause harmful interference to radio communications. Operation of this equipment in a residential area is likely to cause harmful interference in which case the user will be required to correct the interference at his own expense.

FCC WARNING: Changes or modifications not expressly approved by the party responsible for compliance could void the user's authority to operate the equipment.



CONTENTS

IMPORTANT	- Be sure to read this chapter for safe use of the equipment. -	1-11
1	Intended Use.....	5
2	Conformity of the System.....	5
3	Handling Precautions.....	13
4	Maintenance and Storage.....	14
1	SYSTEM CHART	15
2	NOMENCLATURE	16
2-1	DP73/DP73 (For Desktop Computer).....	16
2-2	[OPTIONAL] DP-PXU PCIe Extension Unit (For Laptop Computer).....	18
3	HARDWARE INSTALLATION	19
1	Installing the Low-Profile Bracket.....	19
2	Installing the PCIe Interface Board.....	19
3	Installing the Camera Head.....	23
4	Connecting the Cables.....	25

4 SOFTWARE INSTALLATION.....	29
5 IMAGE ACQUISITION PROCEDURE.....	31
6 EXTERNAL TRIGGERING.....	33
7 SPECIFICATIONS.....	35
9 TROUBLESHOOTING GUIDE.....	40

IMPORTANT

The DP73 microscope digital camera is designed to be connected to a camera adapter mounted on an Olympus UIS2/UIS series of optical microscope (not applicable to the LB series) for use in recording of microscopic magnified images at high speed and highest resolution while maintaining high picture quality and high color reproduction. The DP73 incorporates a variety of functions for supporting image recording under optimum conditions.

When the DP73 microscope digital camera is used with a camera adapter or a microscope from a manufacturer other than Olympus, the optical performance may not be manifested fully.

If the equipment is used in a manner not specified by this manual, the safety of the user may be endangered. In addition, the equipment may also be damaged. Always use the equipment as outlined in this instruction manual.

The following symbols are used to set off text in this instruction manual.

CAUTION: Indicates a potentially hazardous situation which, if not avoided, may result in minor or moderate injury or damage to the equipment or other property. It may also be used to alert against unsafe practices.



⊙ : Indicates commentary (for ease of operation and maintenance).



SAFETY PRECAUTIONS

CAUTION

Never connect or disconnect the interface cable while the standby switch  of the computer is set to ON. Otherwise, malfunction may result.

1. Before connecting or disconnecting the interface cable, make sure that the standby switch  of the computer is set to OFF.
When connecting the interface cable, push in the connector all the way and ensure that the connector will not slip out before setting the standby switch  to ON.
Do not move the computer or apply an impact to it while it is powered ON.
2. The cords and interface cables are vulnerable to bends or twists. Do not apply excessive force to them.
3. To prevent the microscope from toppling down, avoid using microscope attachments that may make the total height of the microscope above 1 meter when they are attached.
4. When installing the PCIe interface board, be sure to hold it by the edge. Never touch the board surface directly, as this will lead to malfunction.



The area (IC) of the PCIe interface board becomes very hot during and immediately after use of the camera. Be careful never to touch them during and after use.

5. For handling of the computer, refer to the separately provided "Computer User's Manual".
6. Connect the power cord correctly and ensure that the **grounding terminal** of the power supply and wall outlet are properly connected. If the equipment is not grounded/earthed, Olympus can no longer warrant the electrical safety performance of the equipment.
7. Lay out the interface cable so that it does not contact the heat generating section such as the lamp housing of the microscope.
8. After operation or in case of abnormality, be sure to disconnect the power cord from the connector on the microscope or from the wall power outlet.
9. Never insert foreign objects into the air vents as this could result in fire and electrical shock.

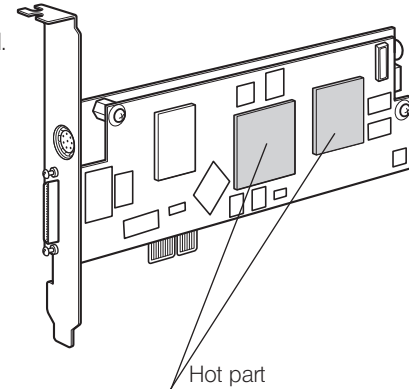



Computer and Software

The computer data may be destroyed by an unexpected event. Be sure to keep a backup of the data.

1. Olympus will not assume any liabilities for any damage incurred due to the use or non-usability of this system, including compensation for the lost data.
2. The computer used with this system should set up and run Microsoft Windows 7 Professional or Ultimate. For the OS in the computer, the user is requested to create a backup and retain it carefully. (Olympus does not support the matters related to the OS including its backup.)
For details on the computer and Microsoft Windows 7, refer to their respective manuals.
3. Olympus guarantees the quality of this product in the factory shipment condition.
Olympus will not assume any liabilities for the operation errors and functional faults incurred due to the alteration of the environmental setup (including BIOS change), installation of other software or addition of hardware to the computer by the user.
4. When the HDD free space reduces, the data processing speed may slow extremely or errors may occur frequently. To prevent this, delete unnecessary data files frequently. For how to delete data files, refer to the manuals for Microsoft Windows 7.
5. Never attempt to delete or rename the folders and files installed by the provided installer software. Otherwise, the software may get unable to be started up.

6. Do not open the housing of the computer and touch the power supply or the circuit board's heat generating section right after use as it may burn your hand. Wait until the internal temperature drops sufficiently.
7. Sharp edges inside the computer may cut your fingers, so take extra care.
8. Use a computer that complies with the safety standards of your country.

1 Intended Use

This device is intended to be used for the capture of digital images for non-clinical diagnostic purposes.

2 Conformity of the System

Restrictions in Use

1. The applicable camera adapter is the U-TV0.5XC-3, U-TV0.63XC-1-2, MVX-TV0.63XC, U-TV1XC or the combination of U-TV1X-2 and U-CMAD3.
The U-TV0.5XC should not be used because it deteriorates the image flatness.
A camera adapter with a magnification below 0.5X cannot be used because part of image will be obscured.
2. When the DP73 is connected to the rear port of the U-DPT(double port tube) or U-MPH(multi port head), the peripheral part of the recorded image may be deteriorated due to the optical performance of the U-DPT or U-MPH.

3. When the U-TV0.5/C-2/U-TV0.5/C-3/U-TV0.63XC-1-2(C mount camera adapter) is used, using two or more intermediate attachments* may obscure the peripheral part of the field of view or may make flare noticeable.

* Example of two intermediate attachments with BX microscope :

Reflected light illuminator + intermediate attachment equivalent to the U-CA.

4. Under fluorescent ring illumination or other AC-driven illumination such as a phase control light intensity adjusting illumination system, the following phenomena may be observed by illumination light flickering because of high light intensity and shortened exposure time :

- Flickering of the displayed image.
- Instability in exposure.
- Hatching patterns in pixel shift recording (4800 x 3600 or 2400 x 1800 pixels, 3CCD mode).

However, provided that the brightness can be adjusted using the light intensity control knob or ND filters, the above phenomena may be attenuated by adjusting the brightness so that the exposure time exceeds 1/50 sec.

For details on the microscope models using AC-driven illumination, contact Olympus.

5. Combinations of this product and non-Olympus microscopes have not been evaluated extensively.

Non-Olympus microscopes and commercially available C-mount lenses can be used provided that they match a CCD with a size of no less than 1/1.8 inch and the lens projection length from the C-mount body attaching section is no more than 4.5 mm. However, problems due to optical adaptability, such as shading, may be observed.

6. When the specimen has a low contrast (near transparent) or high reflectance (mirror status) and the aperture iris diaphragm is stopped down near the smallest aperture, spot flare may be noticeable.
7. When the edge of a non-transmitting object is observed under the STM6 (small measuring microscope) transmitted illumination, flare may be noticeable due to the difference in brightness between the transmitted sections (over-exposure) and non-transmitting sections (under-exposure). To reduce the flare, set a lower exposure using the exposure correction function or setting the exposure manually.
8. When a low-power objective (below 4X) is used, the peripheral part of the field of view may be obscured. In this case, use an ultralow-magnification condenser (U-ULC-2).
9. When the U-CFU (real time confocal unit) is used, it is required to set the exposure to a longer period than 1/30 sec. using the manual exposure mode and control the brightness by engaging or disengaging ND filters.
10. When the specimen has large difference in brightness, particularly when the bright part of the specimen comes on the upper part of the image, red and horizontal flare may be observed. It is noticeable when the AS is being closed. The flare will get unnoticeable when the AS is being opened, though the flare may not be completely removed.
11. When a specimen with high reflectivity is observed with reflected light brightfield observation through the beam splitter of the eyepiece/camera light path of a trinocular tube in combination with the U-TV0.5XC camera adapter, the image in the area outside the CCD's effective image pickup area may be observed as vague ghosts in the peripheral area of the visual field of eyepiece.

12. Flare may be produced during reflected light darkfield observation under overexposure. To reduce the flare, use the exposure correction function or reduce the exposure with manual exposure control.
13. During image acquisition with pixel shifting (4800 x 3600 or 2400 x 1800 pixels, 3CCD mode), the image may be disturbed if the specimen is moved.
14. If the camera or microscope is vibrated during image acquisition with pixel shifting (44800 x 3600 or 2400 x 1800 pixels, 3CCD mode), the image will be disturbed. There are several causes for the vibration which are for example the operation of keyboard/mouse on the same table where the microscope equipped with the camera is placed, or vibration from the instrument equipped with an air cooling fan, etc.

Operating Environment

Temperature: 10 to 35°C.

Humidity: 20% to 85% (without condensation).

See page 39 for details.

Recommended Monitor Specifications

- A monitor with the 1280 x 1024 or larger full-color display capability.
- An Adobe RGB compatible monitor, provided that the camera head is used in the Adobe RGB mode.

Recommended Computer Specifications – Desktop Computer –

1. Computer requirements

	PC/AT compatible
CPU	Intel Core series 1.8 GHz or greater [Core2 Duo E6400, 2.13 GHz or greater recommended]
RAM	4 GB or more
HDD	Free space 1 GB or more
Graphic	PCI Express X16 VGA card with 1280 x 1024 or more and 32-bit color capability. On-board graphic also acceptable.
Extension slot	PCI Express Rev. 1.0a or later. Half-size or low-profile PCIe board compatible (106.7 mm x 174.6 mm)
OS	Windows 7 Professional/Ultimate (64 bit) Language: English or Japanese
Power	250 W or more. (With CE marking) * There needs to be the FDD power cable, HDD(4-pin) power cable or SATA power cable which is not occupied.

2. CPU

We do not guarantee performance if the computer uses a CPU other than or incompatible with Core series or uses a non-Intel chipset.

3. HDD free space

The HDD free space (the value 1GB or more in Page 9) is the space that does not cause a special problem when the system is installed or run. The space required for saving an image file in the HDD is slightly more than 5.6 MB with a 1600 x 1200-pixel (24-bit) non-compressed image and slightly more than 50 MB with a 4800 x 3600-pixel (24-bit) non-compressed image. In consequence, the HDD should also provide a considerably large space for saving these image files.

When saving movies in the HDD stack, the space required for saving a movie is about 80 MB (max.) per second. The movie recording time is limited according to the HDD free space.

4. RAM

If a RAM other than a PC2700 or greater, dual-channel RAM is used, the full-size live frame rate may drop.

5. Monitor

Use an Adobe RGB compatible monitor when using the camera head in the Adobe RGB mode.

Optimum color reproduction is not available if the sRGB/Adobe RGB setting of the camera head does not match the setting of the monitor.

6. Sequential connection of PCIe units

Up to two PCIe units including the DP73 and a PCI interface board of the DP72/DP71/DP70/DP30BW or FV1000 (FV10-ASW-V1.5 or later) can be connected in series. Series connection of the FV300/FV500 is not possible.

However, their simultaneous operation is not available so it is required to select either PCI interface operation.

7. Power supply

The PCIe interface board should be powered by connecting the FDD power supply connector from the ATX power supply in the computer.

If your computer does not have an available FDD power cable or the FDD power cable is too short, use the provided HDD(4-pin) to FDD power conversion cable for the power supply.

And if your computer does not have an available HDD power cable (4-pin), use the provided SATA-to-HDD(4-pin) power conversion adapter and HDD(4-pin)-to-FDD power conversion cable for the power supply.

Recommended Computer Specifications – Laptop Computer –

1. Computer requirements

	PC/AT compatible
CPU	Intel Core series 1.8 GHz or greater [Core2 Duo T7300, 2.0 GHz or greater recommended]
RAM	4 GB or more
HDD	Free space 1GB or more
Graphic	On-board graphic with 1280 x 1024 or more and 32-bit color capability.
Card slot	ExpressCard/34 or ExpressCard/54
OS	Windows 7 Professional/Ultimate (64 bit) Language: English or Japanese

2. CPU

We do not guarantee performance if the computer uses a CPU other than or incompatible with Core series or uses a non-Intel chipset.

3. HDD free space

The HDD free space (the value 1GB or more in Page 9) is the space that does not cause a special problem when the system is installed or run. The space required for saving an image file in the HDD is slightly more than 5.6 MB with a 1600 x 1200-pixel (24-bit) non-compressed image and slightly more than 50 MB with a 4800 x 3600-pixel (24-bit) non-compressed image. In consequence, the HDD should also provide a considerably large space for saving these image files.

When saving movies in the HDD stack, the space required for saving a movie is about 80 MB (max.) per second. The movie recording time is limited according to the HDD free space.

4. RAM

If a RAM other than a PC2700 or greater, dual-channel RAM is used, the full-size live frame rate may drop.

5. Monitor

Use an Adobe RGB compatible monitor when using the camera head in the Adobe RGB mode.

Optimum color reproduction is not available if the sRGB/Adobe RGB setting of the camera head does not match the setting of the monitor.

6. ExpressCard

The ExpressCard tends to slip out easily from the computer. Be sure not to disconnect the ExpressCard during operation. For protection from possible damage, do not apply excessive force to the ExpressCard.

Insert or remove the ExpressCard after the PC is shut down.

Handling Precautions

1. This camera head is a precision instrument. Handle it with care and avoid subjecting it to a sudden or severe impact.
2. The image displayed on the monitor may be affected when it is used at a place close to equipment generating strong electromagnetic waves. This is not a malfunction and will not affect the actual image being recorded. To avoid interference during operation, keep the system far from any source of electromagnetic waves.
3. As the camera head is heavy, hold it carefully not to drop when mounting or storing.
4. Do not use the camera in areas where it may be subjected to direct sunlight, high temperature, humidity, dust, or vibrations. (For the operating environment conditions, see chapter 8, "SPECIFICATIONS" on page 35.)
5. Be sure to install the PCIe Extension Unit without blocking the opening for ventilation provided on it.
6. The camera head needs to be calibrated periodically (approx. every 3 months) for the level variations caused by the influence of cosmic rays. For the calibration method, refer to the CCD Calibration in the online manual for the cellSens or OLYMPUS Stream software.
7. As a countermeasure against computer virus infection, it is recommended to install an anti-virus software on the PC. Operation speeds of the cellSens/OLYMPUS Stream may slow down depending on the anti-virus software.

4 Maintenance and Storage

1. To clean the lenses and other glass components, simply blow away dirt using a commercially available blower and wipe gently using a piece of cleaning paper (or clean gauze).
If a lens is stained with fingerprints or oil smudges, wipe it with gauze slightly moistened with commercially available absolute alcohol.

CAUTION Since the absolute alcohol is highly flammable, it must be handled carefully. To prevent fire ignition, be sure to keep it away from open flames or potential sources of electric sparks – for example, electrical equipment that is being switched on or off.

Also remember to always use these chemicals only in a well-ventilated room.

2. Parts other than the glass components should be cleaned by wiping with a clean cloth. Do not use organic solvents to remove major stains. Use a soft cloth slightly moistened with a neutral detergent solution.
3. Do not disassemble any part of the camera as this could result in malfunction or reduced performance.
4. When the camera is removed from microscope for storage, be sure to put the C-mount cap included in the camera, which is necessary to protect the IR cut filter provided inside.
5. When the camera is stored, be sure to keep the C-mount portion downward, since it tends to roll over.
6. When disposing of this product, check your local regulations and rules and be sure to observe them strictly.

1 SYSTEM CHART

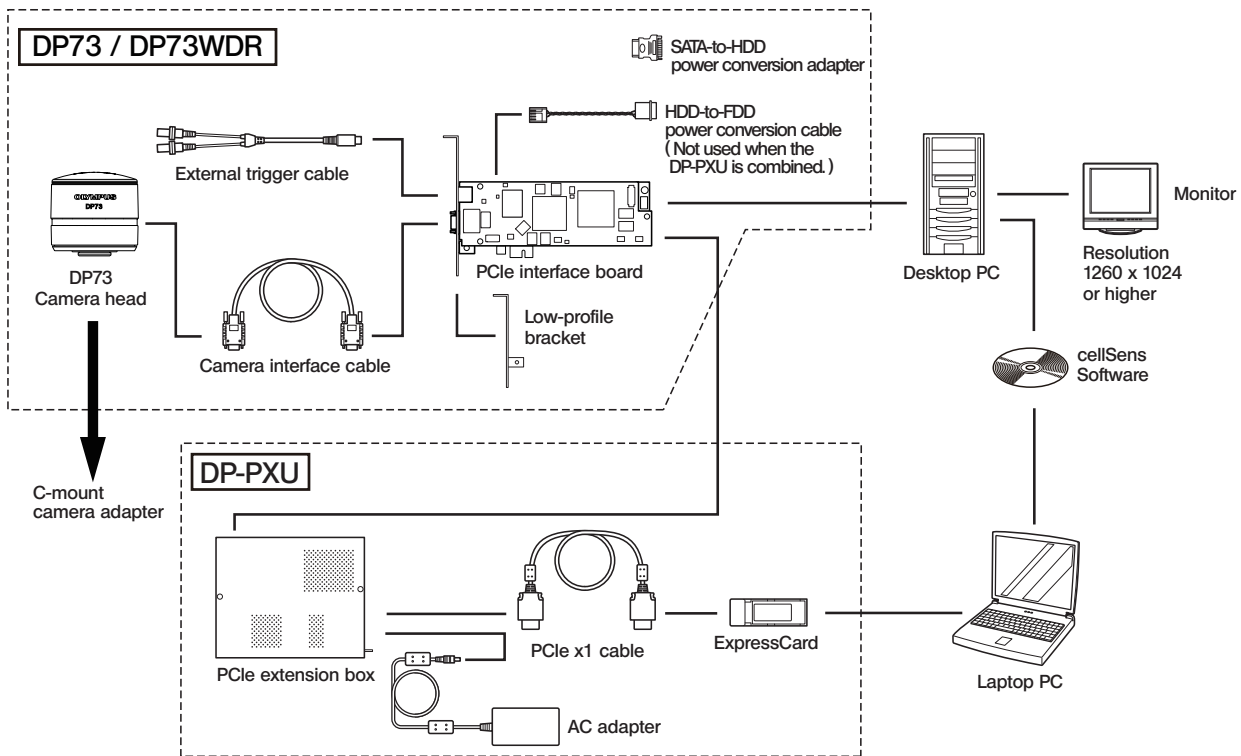

© Consult Olympus for the microscope, camera adapter and DP2-TWAIN to be used together.

2 NOMENCLATURE

2-1 DP73 / DP73WDR (For Desktop Computer)

Camera Head

CAUTION Any equipment connected to the camera head should be an Olympus-designated product or a product in compliance with the requirements of IEC60950 or CISPR22/24. If equipment other than these products is connected, Olympus cannot guarantee any performance of the camera.

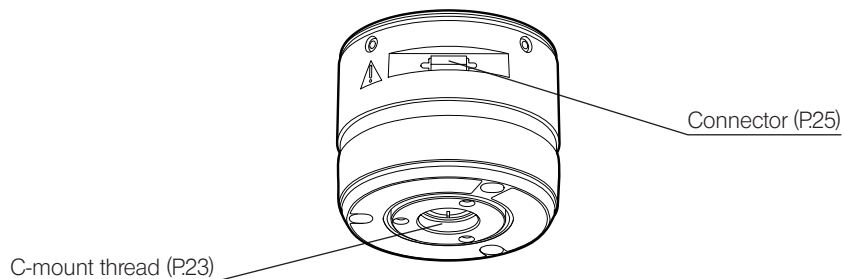

PCIe Interface Board (PCI standard half-size, low-profile size compatible)

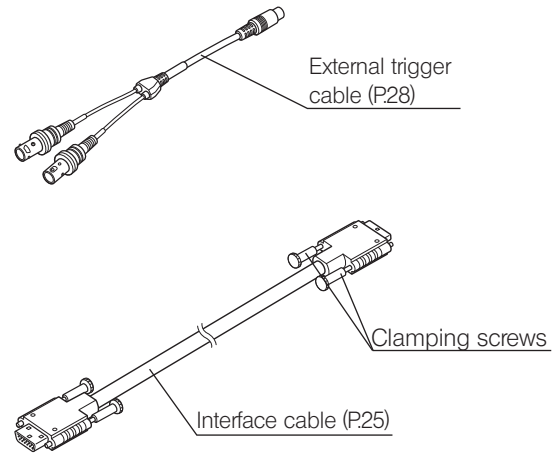
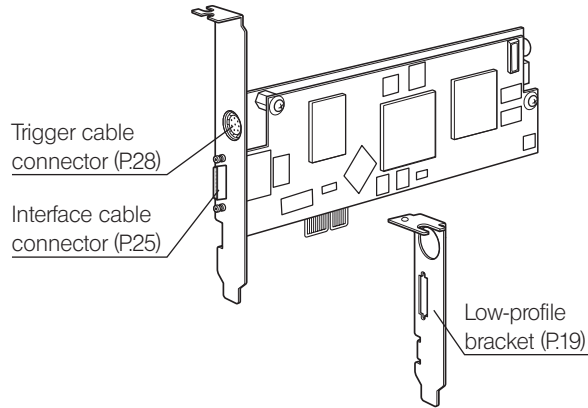

Software (DVD-ROM)

Software (optional)
cellSens / OLYMPUS Stream

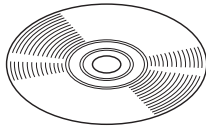

Dongle

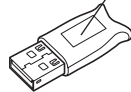

SATA-to-HDD(4-pin)
power conversion adapter

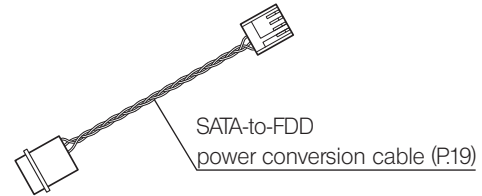

2-2 [OPTIONAL] DP-PXU PCIe Extension Unit (For Laptop Computer)

PCIe Extension Box

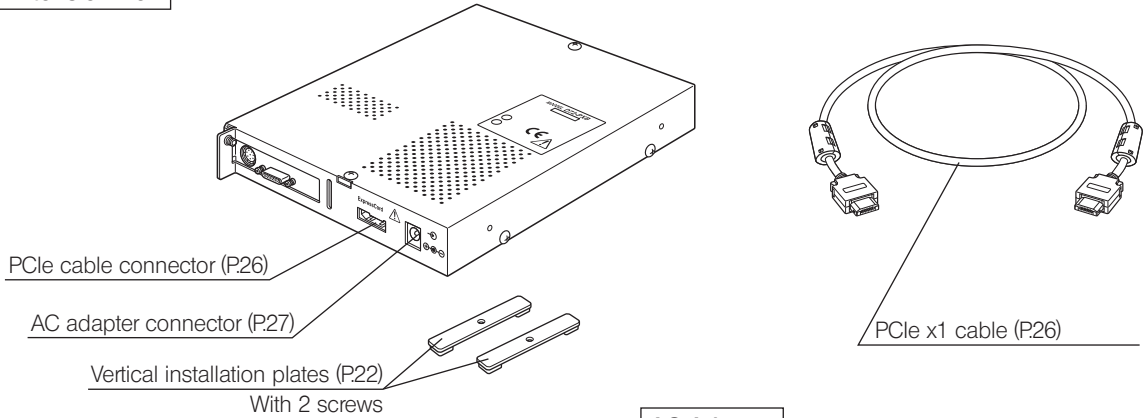

ExpressCard

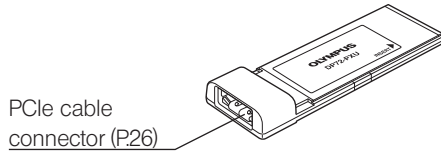

AC Adapter

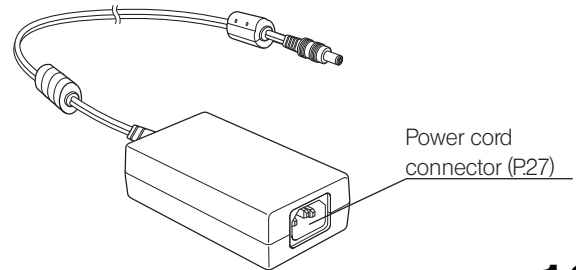

3 HARDWARE INSTALLATION

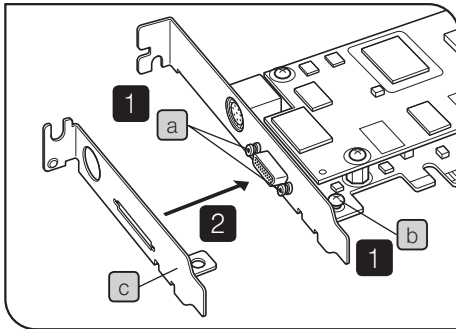

Fig. 1

1 Installing the Low-Profile Bracket (Fig. 1)

If the computer's extension slot is of the low-profile specifications or the PCIe extension box is used, it is required to replace the existing bracket with the low-profile bracket.

- 1 Prepare flat-blade and Phillips screwdrivers and remove the “ - ” screws **a** and the “ + ” screw **b**.
- 2 Replace the existing bracket with the low-profile bracket **c** and attach screws **a** **b**.

CAUTION Do not provide excessive force when tightening the screws of PCIe I/F board, since they may be damaged if tightened excessively.

2 Installing the PCIe Interface Board (Fig. 2 - Fig. 6)

DP73 / DP73WDR (For Desktop Computer) Set (Figs. 2 & 3)

- CAUTION**
- Before installing the PCIe interface board in the computer, be sure to read the instruction manual for the computer in order not to damage it.
 - Be sure to turn off the computer and peripherals and unplug their power cords before installing the PCIe interface board.
 - To avoid damage due to static electricity, touch an unpainted metallic surface of the computer with your hand to discharge the static electricity before installation.
 - The SATA-to-HDD(4-pin) power conversion adapter is sensitive to excessive force. Please handle it with care.

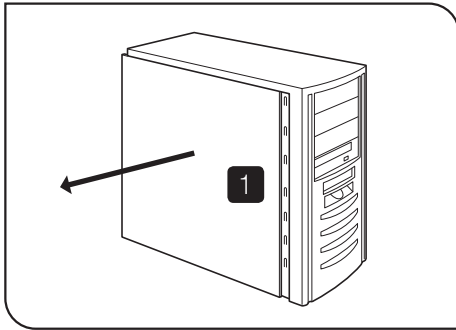

Fig. 2

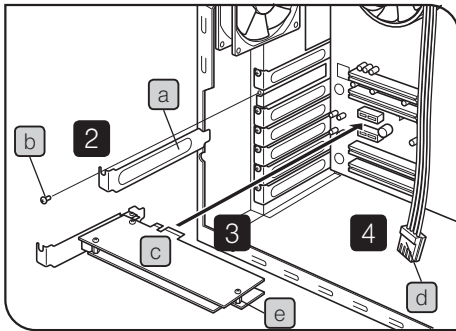

Fig. 3

- 1 Open the housing of the computer.
- 2 Remove the clamping screw **b** of the slot cover **a** of an unused PCIe slot on the motherboard and remove the cover.
- 3 Insert the PCIe interface board **c** carefully without touching the board surface directly by hand, and attach the slot cover using the clamping screw **b** removed above.
- 4 Connect the FDD power cable **d** from the computer's power supply to the power connector **e** on the PCIe interface board **c**. If your computer does not have an available FDD power cable or the FDD power cable is too short, connect the provided HDD-to-FDD power conversion cable from the computer's HDD power cable to the power connector **e** on the PCIe interface board **c**. And if your computer does not have an available HDD(4-pin) power cable, connect the provided SATA-to-HDD(4-pin) power conversion adapter and HDD(4-pin)-to-FDD power conversion cable from the computer's SATA power cable to the power connector **e** on the PCIe interface board **c**.
- 5 Close the computer housing.

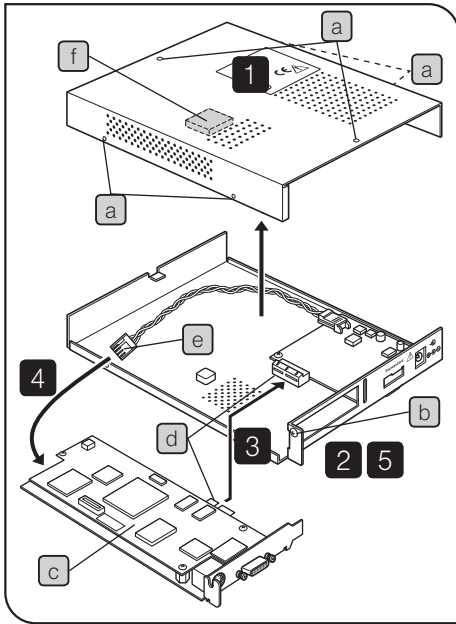

Fig. 4

Optional DP-PXU (Figs. 4 & 5)

- 1 Using a Phillips screwdriver, remove the six screws **a** of the top cover of the extension box and then remove the cover .
- 2 Remove the bracket clamping screw **b**.
- 3 Connect the PCIe interface board **c** with low-profile bracket to the connector **d**.
- 4 Connect the connector **e** to the PCIe interface board.
- 5 Attach the clamping screw **b** removed above.
- 6 A thermal conduction sheet **f** is attached on the back of the top cover. Remove the tapes **g** and the protective sheet **h** carefully without displacing the thermal conductive sheet (Fig. 5).
- 7 Place the top cover in the original position and attach the clamping screws **a**.

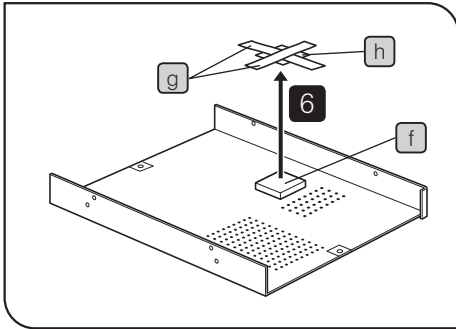

Fig. 5

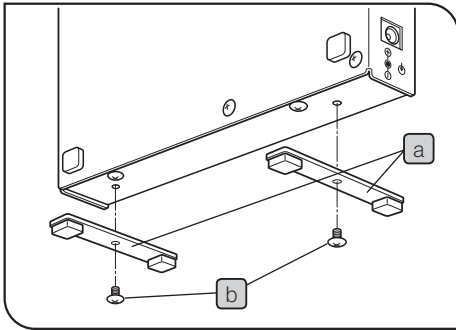

Fig. 6

Installing the PCIe Extension Box (Fig. 6)

- The PCIe extension box can be installed either horizontally or vertically.

Horizontal Installation

Place the PCIe extension box on the desktop so that the surface with rubber feet faces down.

Vertical Installation

Attach the provided plates **a** to the side panel of the extension box using provided screws **b**.

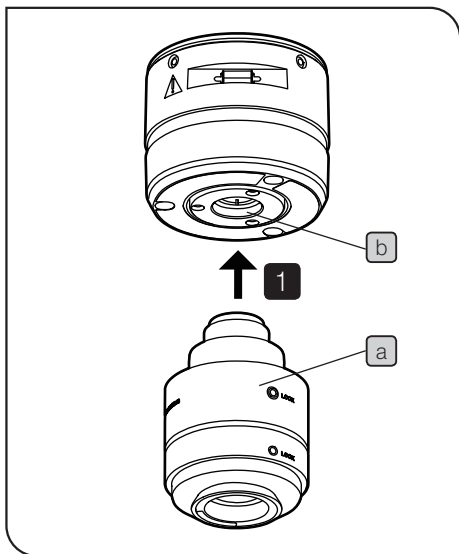

Fig. 7

3 Installing the Camera Head

(Fig. 7)

CAUTION

- The C-mount thread has a sharp edge that should not be touched.
 - The camera head and camera adapter are precision modules. Be careful not to drop them during attaching or detaching.
- ◎ The following procedure deals with the case using the U-TV1XC C-mount camera adapter.
- 1 Screw in the U-TV1XC C-mount camera adapter **a** into the mount thread **b** at the bottom of the camera head.

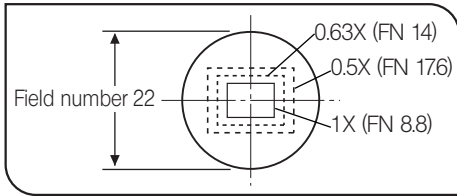
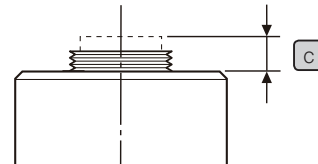

Fig. 8

- If the acquired field is as shown in Fig. 8, use a camera adapter having magnification of 0.5X to 1X. (If a 0.35X camera adapter is used, the peripheral part of the image will be obscured.)
- If a C-mount camera adapter from other manufacturer than Olympus is used, the optical performance of the system may not be manifested fully.

CAUTION Be careful in using other manufacturer's C-mount camera adapter or C-mount lens having a thread length c over 4.5 mm. Otherwise, the threaded section will hit the inside of the camera head and cause damage to it.

Be sure to adjust the parfocality between the C-mount camera adapter and the eyepieces. Otherwise, the image through the camera and the image through the eyepieces are not parfocal. For the parfocality adjustment method, refer to the instruction manual for the camera adapter in use.



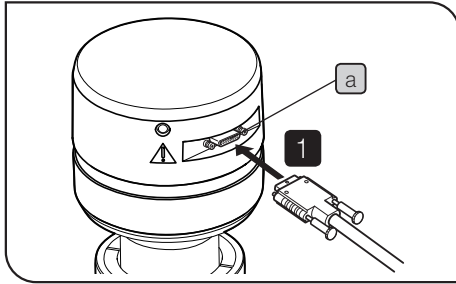

Fig. 9

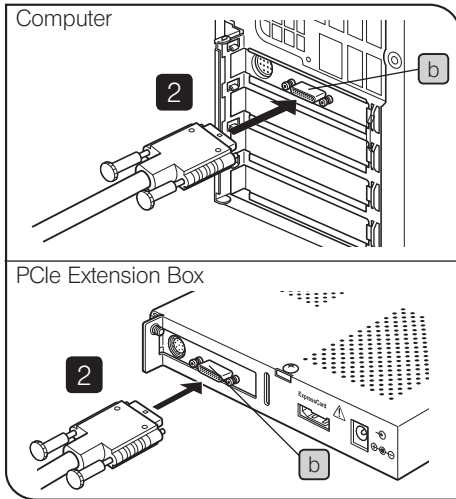

Fig. 10

4 Connecting the Cables

(Fig. 9 - Fig. 13)

CAUTION

- The cords and cables are vulnerable to bend or twist. Do not apply excessive force to them.
- Be sure to switch off the computer before proceeding to the connections.
- Always use the cables designated by Olympus.
- When connecting the cable, insert the connector plug in the proper direction.
- Keep the cables well away from the equipments generating high heats, such as the lamp housing of microscope.

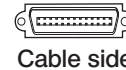

Cable side



Camera head/
Computer/
PCIe Extension Box side

Connecting the Interface Cable (Figs. 9 & 10)

- 1 Insert the connector of the interface cable all the way into the connector **a** of the camera head and secure the clamping screws on both sides of the connector, and check that the interface cable will not slip out.
- 2 Insert the connector of the interface cable all the way into the connector **b** of the Computer or PCIe Extension Box and secure the clamping screws on both sides of the connector, and check that the interface cable will not slip out.

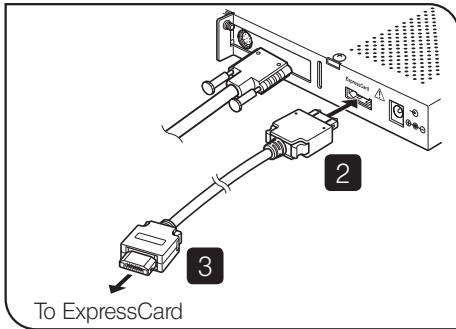

Fig. 11

Connecting the ExpressCard and PCIe x1 Cable (Fig. 11)

CAUTION Insert the cable connectors all the way.

- 1** Insert the ExpressCard all the way into the card insertion slot* of the laptop computer.
 - * ExpressCard/34 slot: Hold the card with the surface marked "INSERT" facing up and insert.
 - ExpressCard/54 slot: Hold the card with the surface marked "INSERT" facing up and insert it along the left edge of the slot.
- 2** Check the orientation of the connector of the PCIe x1 cable and insert it into the connector on the PCIe extension box.
- 3** Insert the connector into the ExpressCard.

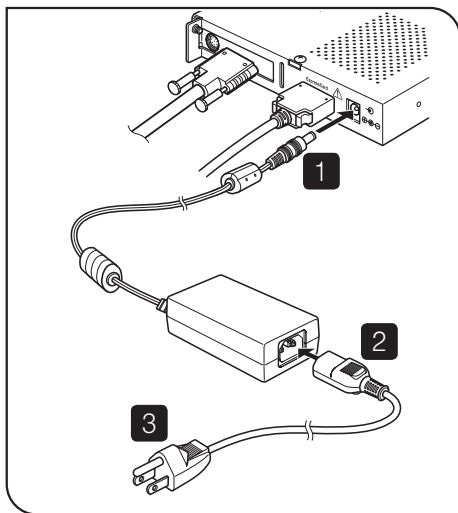

Fig. 12

Connecting the AC Cable (Fig. 12)

CAUTION

- Insert the cable and power cord connectors all the way.
- Always use the power cord provided by Olympus. If no power cord is provided with the camera head, please select the proper power cord by referring to chapter “PROPER SELECTION OF THE POWER SUPPLY CORD” at the end of this instruction manual.
- If the equipment is not grounded/earthed, Olympus can no longer warrant the electrical safety performance of the equipment.

- 1 Insert the connector of the AC adapter into the connector on the PCIe extension box.
- 2 Insert the connector of the power cord to the connector on the AC adapter.
- 3 Insert the power cord plug into the power outlet.

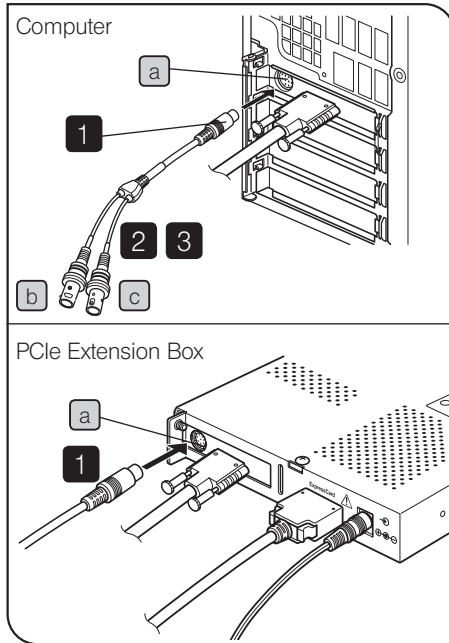

Fig. 13

Connecting the External Trigger Cable (Fig. 13)

- 1 Insert the connector of the external trigger cable to the connector **a** on the PCIe interface board in the computer or the PCIe extension box.
- 2 When using the trigger input, connect the red cable (marked "I") **b** to the BNC connector.
- 3 When using the trigger output, connect the white cable (marked "O") **c** to the BNC connector.

CAUTION The external triggering is available only when the cellSens / OLYMPUS Stream software is run.

4 SOFTWARE INSTALLATION

Software cellSens / OLYMPUS Stream

Install the software cellSens / OLYMPUS Stream by referring to the cellSens / OLYMPUS Stream instruction manual.

Image acquisition software DP2-TWAIN

When you want to use the Image acquisition software DP2-TWAIN, consult Olympus.

Before Installation (Applicable OS: Windows® 7)

- Quit all running applications before installing cellSens or OLYMPUS Stream.
- The software cannot be installed unless the user account is registered as “computer administrator.”
If the user account is registered as a “Restricted account,” change it to the “Computer administrator” account.
(For the user account registration, refer to the instruction manuals for your computer.)

Trademark Information

Windows is a registered trademark of Microsoft Corporation.
All other brand and product names are trademarks or registered trademarks of their respective owners.

Selection of the devices for DP-PC-S/DP-PC and DP-PCWDR

Refer to the following windows at the selection of devices in the cellSens / OLYMPUS Stream. An device list is displayed at the time of first start up of the software. The device list can be also displayed by clicking the tabs of [Acquire], [Devices] and then [Device list] on the Menu bar.

In case DP73 is used

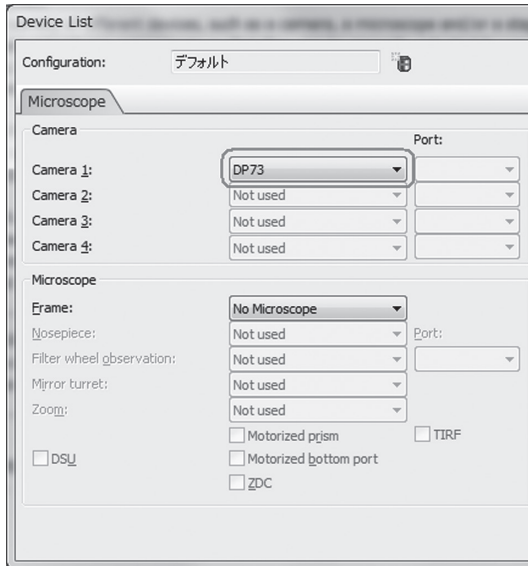

In case DP73WDR is used

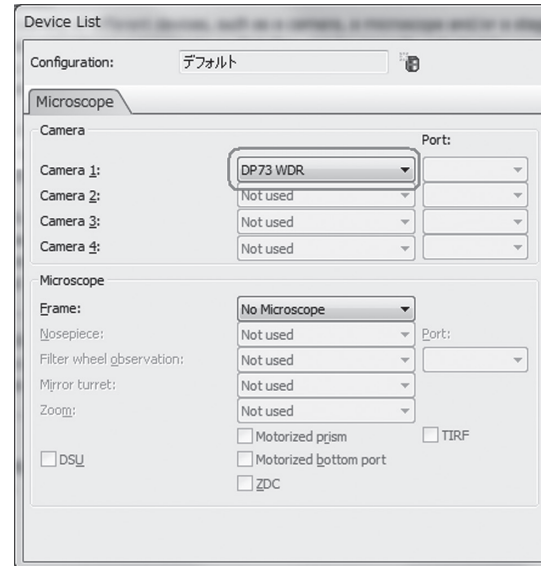

5 IMAGE ACQUISITION PROCEDURE

For the details, refer to the Instruction Manual or Help of Software you will use.

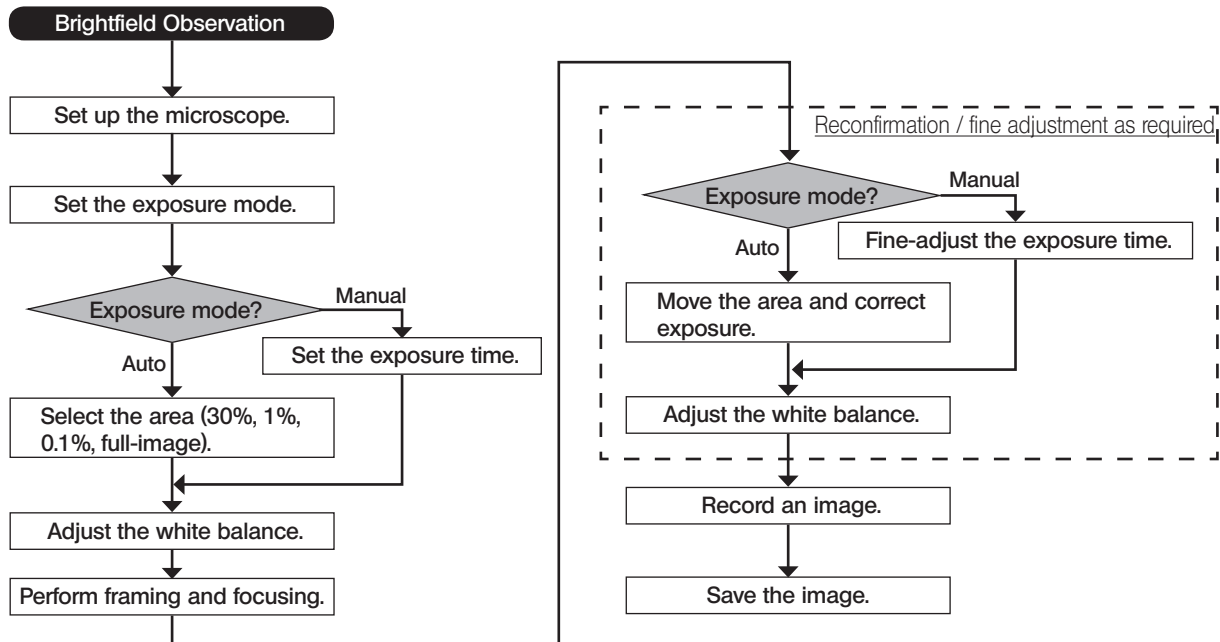

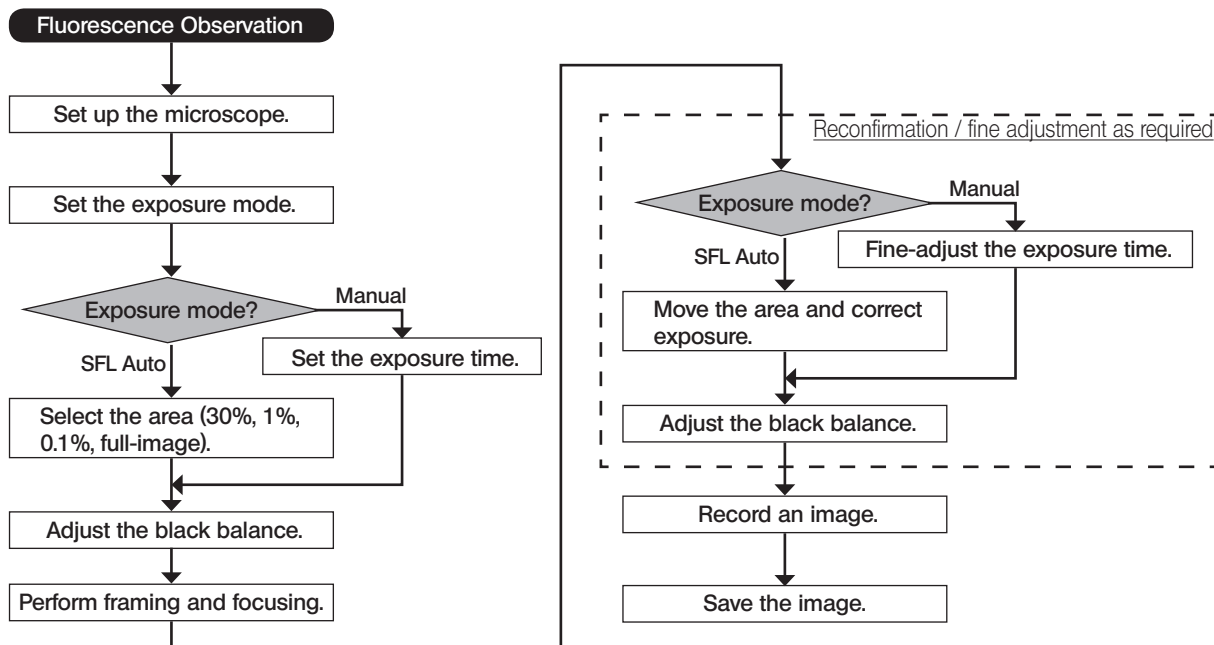

6 EXTERNAL TRIGGERING

- When the cellSens / OLYMPUS Stream software is used, the DP73 can record still images or control a commercially available shutter based on an external trigger signal.

Trigger Input

- The trigger input from external equipment can be used to start still image acquisition using the cellSens / OLYMPUS Stream.
- The trigger input is detected at the edge and the cellSens / OLYMPUS Stream starts to acquire the images based on the preset exposure time. The positive and negative logics can be switched with the cellSens / OLYMPUS Stream.
- The exposure is started within 100 μ sec after the trigger input.
- The trigger input is a TTL compatible signal.

V_{IH} : 2.0 V (min.). V_{IL} : 0.8 V (max.).

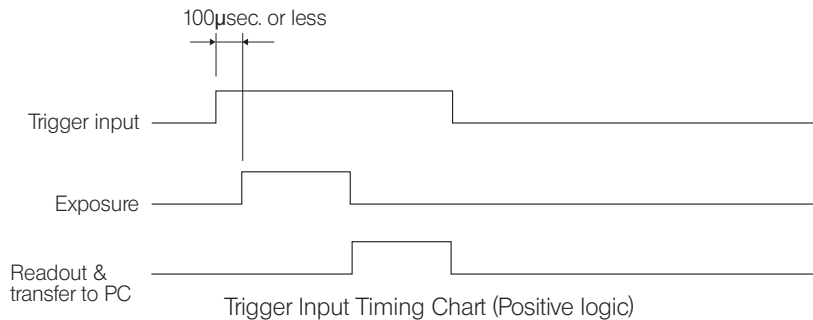

Trigger Output

- The trigger output can be used to control a commercially available shutter.
- The positive and negative logics of the trigger output can be switched with the cellSens / OLYMPUS Stream.
- The trigger output is interlocked with the shutter release/close operations of the cellSens / OLYMPUS Stream.
- The external trigger signal is output by starting still image acquisition when the shutter is closed.
- The time lag from the trigger output to the start of exposure can be set between 0 and 2 sec. on the cellSens / OLYMPUS Stream.
- The trigger output is a TTL compatible signal.

V_{OH} : 2.4 V (min). V_{OL} : 0.4 V (max).

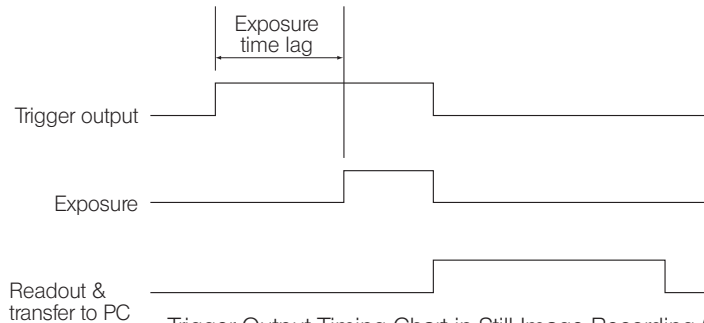

Trigger Output Timing Chart in Still Image Recording (Positive logic)

7 SPECIFICATIONS

DP73 Specifications

* These items can be set from the cellSens / OLYMPUS Stream.

** The values of these items are variable depending on the exposure time setting and the computer operating situations.

Item	Specifications
Camera system	Single-CCD color camera Pixel shifting type
Image pickup device	1/1.8-inch color CCD Total pixels: 2.1 million pixels Effective pixels: 2.01 million pixels Pixel pitch: 4.40 μm (H) x 4.40 μm (V) Scanning method: progressive scanning
Cooling	Peltier cooling Natural air cooling CCD temperature: room temperature - 10°C (max.)
Recorded image sizes	4800 x 3600 (pixel shifting, 3CCD mode*) 2400 x 1800 (pixel shifting, 3CCD mode*) 1600 x 1200 (1 x 1, 3CCD mode)* 800 x 600 (1 x 1) 800 x 600 (2 x 2) * 3CCD mode is an application of the pixel shift function, which is the mode to acquire the image with RGB color in every pixel.
Camera mount	C-mount

Item		Specifications
ISO speed		ISO 100/200/400/800/1600 equivalent
A/D		14 bits
Exposure control	Exposure modes	Auto SFL Auto Manual
	AE lock	Available
	Exposure correction	Correction range: ±2.0 EV. Step: 1/3 EV
	Metering area	Full image 30% 1% 0.1% The metering area is freely movable.
Exposure time		1/44,000 to 60 sec
Binning		2 x 2
Live frame rate**		1600 x 1200 (1 x 1): 15 fps 800 x 600 (1 x 1): 15 fps 800 x 600 (2 x 2): 27 fps
Color modes		Color standard gray scale custom gray scale

Item		Specifications
External triggering*		Input: Random trigger input (Edge trigger mode) Output: Trigger output With exposure time lag (0 to 2 sec. in 10 msec. steps) TTL compatible
Image accumulation*	Modes	Integral, averaging
	Accumulation count	64 frames (max.)
White balance modes		Area-specified auto Manual
Black balance modes		Area-specified auto Manual
Contrast modes		Low Standard High Linear
Sharpness filter		Low Standard High
Wide dynamic range correction		Available (only with the DP-PCWDR)
Pixel shift bleaching correction		Available
Color space*		sRGB Adobe RGB

Item	Specifications
Focus indicator	Contrast bar Line profile
Interval recording*	Interval: 1 sec. to 24 h.59 m.59 sec Number of shootable frames: 3000
Image file formats	Dependent on the application software
Preview quality modes	Standard / Medium / High
Computer interface	PCI Express Rev. 1.0a or later ◁Desktop computer▷ Compatible with half-size or low-profile size ◁Laptop computer▷ ExpressCard/34 (also usable for ExpressCard/54)
Compatible OS	RAM: 4 GB or more OS: Windows 7 Professional/Ultimate (64 bit) Language: English or Japanese

Item		Specifications
Dimensions & weight	〈DP73〉	
	Camera head	185.4(φ) x 776(H) mm (excluding projections), approx. 900 grams
	PCIe interface board	181(W) x 121(D) x 21.6(H) mm (excluding projections), approx. 200 grams
	Interface cable	Approx. 2.8 meters
	External trigger cable	Approx. 0.2 meter
	〈 PCIe Extension Unit 〉	
	PCIe extension box	203(W) x 165(D) x 28(H) mm (excluding projections), approx. 720 grams
	ExpressCard	100(W) x 34(D) x 11(H) mm (excluding projections), approx. 25 grams
	AC adapter	61(W) x 133(D) x 41(H) mm (excluding projections), approx. 480 grams Cord length: Approx. 2.0 meter 100-240V 2A 50/60Hz
	PCIe x1 cable	Approx. 1.7 meter
Storage environment		-20 to 60 °C 10 % to 90 % (without condensation)
Operating environment		<ul style="list-style-type: none"> • Indoor use. • Altitude: max. 2000 meters • Ambient temperature: 10° to 35°C (50° to 95° F) • Relative humidity: 20% to 85% (without condensation) • Supply voltage fluctuations; ±10%. • Pollution degree: 2 (in accordance with IEC60664-1) • Installation/Overvoltage category: II (in accordance with IEC60664-1)

9 TROUBLESHOOTING GUIDE

Under certain conditions, the performance of the camera may be adversely affected by factors other than defects. If problems occur, please review the following list and take remedial action as needed. If you cannot solve the problem after checking the entire list, please contact Olympus for assistance.

Problem	Cause	Remedy	Page
The computer will not start up.	The camera and computer are connected improperly.	Connect the camera head and computer properly.	25
	The software is installed improperly.	Install the software.	29
Live image is not displayed.	The camera and computer are connected improperly.	Connect the camera head and computer properly.	25
	The microscope illumination is off. The microscope is not set to the camera light path. The illumination or specimen focusing is adjusted improperly.	Turn on the microscope illumination, adjust the lighting and focusing correctly, and select the camera light path.	–
	The ISO speed or exposure time is set improperly.	Set the ISO speed, exposure mode, exposure time and level properly.	(Online manual)

Problem	Cause	Remedy	Page
Still images cannot be recorded.	The camera and computer are connected improperly.	Connect the camera head and computer properly.	25
	The cellSens or OLYMPUS Stream is processing recording.	Wait until the recording processing completes before starting recording of the next image. In certain cases, it may be required to press the Cancel button on the status bar and record the image again.	(Online manual)
	The cellSens / OLYMPUS Stream is processing file save, etc.	Wait until the processing completes before starting recording of the next image.	(Online manual)
	The computer memory is insufficient.	Exit from other software before retrying recording.	-

Problem	Cause	Remedy	Page
Picture is too bright.	Exposure correction is set in the + direction.	Return the exposure correction value to 0 and set the desired exposure correction value.	(Online manual)
	The metering area is set to a dark area outside the region of interest.	Move the metering area to the area where you want to obtain optimum exposure.	(Online manual)
	AE lock, which was set when the exposure time was longer than the currently required exposure time, is active.	Cancel AE lock.	(Online manual)
	The input highlight level adjustment is too low.	Reset the current level adjustment and adjust the optimum level again.	(Online manual)
	The microscope illumination is too bright.	Reduce the microscope illumination intensity or engage an ND filter to reduce brightness.	-

Problem	Cause	Remedy	Page
Picture is too dark.	Exposure correction is set in the – direction.	Return the exposure correction value to 0 and set the desired exposure correction value.	(Online manual)
	The metering area is set to a bright area outside the region of interest.	Move the metering area to the area where you want to obtain optimum exposure.	(Online manual)
	AE lock, which was set when the exposure time was shorter than the currently required exposure time, is active.	Cancel AE lock.	(Online manual)
	The output highlight level adjustment is too low.	Reset the current level adjustment and adjust the optimum level again.	(Online manual)
	The microscope illumination is too dark.	Increase the microscope illumination intensity or disengage the existing ND filter to increase brightness.	–

Problem	Cause	Remedy	Page
The colors in the picture are strange.	The area selected in white balance adjustment was improper.	Select a white area with the rectangular white balance adjustment area.	(Online manual)
	The RGB balance is adjusted improperly in manual white balance adjustment.	Perform manual white balance adjustment to adjust the RGB color balance to obtain optimum colors.	(Online manual)
	The area selected in black balance adjustment was improper.	Select a black area with the rectangular black balance adjustment area.	(Online manual)
	The screen color setting of the computer is incorrect.	Set the computer display color to 24-bit color or higher. The recommended setting is 32-bit color.	-
	Color spaces (sRGB/AdobeRGB) of the camera and the monitor are different.	Set the Color space (sRGB/Adobe RGB) of the camera so that it becomes identical to that of the monitor.	(Online manual)

Problem	Cause	Remedy	Page
The picture is not in focus.	The specimen is not in focus properly.	Adjust the focus correctly with the fine adjustment knob.	-
	The aperture iris diaphragm of the condenser is open too wide.	Close the aperture iris diaphragm a little.	-
	The field iris diaphragm is not set properly.	Adjust the field iris diaphragm until the image circumscribes the field of view.	-
	Lens components of the microscope are contaminated or the cover glass on the front of the camera is stained.	Clean the objective, camera adapter lens, condenser and/or window lens of the microscope, or clean the cover glass on the bottom of the camera head.	14
	The microscope and/or camera are subjected to vibration during recording.	Acquire images in an environment in which the microscope and camera are not vibrated. It is effective to use an anti-vibration bench.	-
The 4140 x 3096 and 2070 x 1548 images are not neat.	The camera is subjected to vibration during recording.	Acquire images in an environment in which the microscope and camera are not vibrated. It is effective to use an anti-vibration bench.	-

Problem	Cause	Remedy	Page
It is impossible to open the file correctly, by the software other than cellSens/OLYMPUS Stream, in which the image acquired by 12bit color/12bit grey scale is saved. Or, the image in black color is displayed (including the icon on the window).	Effective data is low 12 bits out of 16 bits file format. However, your software does not accept 16 bits format or use high 8 bits for display.	Use cellSens/OLYMPUS Stream to open the file.	-
The cellSens or OLYMPUS Stream window is not displayed correctly or the menu characters are not displayed correctly.	The resolution setting of the screen is incorrect.	Set the resolution setting at 1280 x 1024 or more in the property of the screen.	-
	The large font has been selected for the font size of the screen.	Select a small font in the property of the screen.	-
External trigger signal is not output.	External triggering is not enabled.	Enable external triggering on the cellSens / OLYMPUS Stream.	(Online manual)
Still image cannot be acquired using the external trigger input.	External triggering is not enabled.	Enable external triggering on the cellSens / OLYMPUS Stream.	(Online manual)

■ PROPER SELECTION OF THE POWER SUPPLY CORD

If no power supply cord is provided, please select the proper power supply cord for the equipment by referring to “Specifications” and “Certified Cord” below:













CAUTION In case you use a non-approved power supply cord for Olympus products, Olympus can no longer warrant the electrical safety of the equipment.

Specifications

Voltage Rating	125V AC (for 100-120V AC area) or, 250V AC (for 220-240V AC area)
Current Rating	6A minimum
Temperature Rating	60°C minimum
Length	3.05 m maximum
Fittings Configuration	Grounding type attachment plug cap. Opposite terminates in molded-on IEC configuration appliance coupling.

Table 1 Certified Cord

A power supply cord should be certified by one of the agencies listed in Table 1 , or comprised of cordage marked with an agency marking per Table 1 or marked per Table 2. The fittings are to be marked with at least one of agencies listed in Table 1. In case you are unable to buy locally the power supply cord which is approved by one of the agencies mentioned in Table 1, please use replacements approved by any other equivalent and authorized agencies in your country.

Country	Agency	Certification Mark	Country	Agency	Certification Mark
Argentina	IRAM		Italy	IMQ	
Australia	SAA		Japan	JET, JQA, TÜV, UL Japan/METI	
Austria	ÖVE		Netherlands	KEMA	
Belgium	CEBEC		Norway	NEMKO	
Canada	CSA		Spain	AEE	
Denmark	DEMKO		Sweden	SEMKO	







Country	Agency	Certification Mark	Country	Agency	Certification Mark
Finland	FEI		Switzerland	SEV	
France	UTE		United Kingdom	ASTA BSI	
Germany	VDE		USA	UL	
Ireland	NSAI				

Table 2 HAR Flexible Cord

APPROVAL ORGANIZATIONS AND CORDAGE HARMONIZATION MARKING METHODS

Approval Organization	Printed or Embossed Harmonization Marking (May be located on jacket or insulation of internal wiring)	Alternative Marking Utilizing Black-Red-Yellow Thread (Length of color section in mm)		
		Black	Red	Yellow
Comite Electrotechnique Belge (CEBEC)	CEBEC <HAR>	10	30	10
Verband Deutscher Elektrotechniker (VDE) e.V. Prüstelle	<VDE> <HAR>	30	10	10
Union Technique de l'Electricite' (UTE)	USE <HAR>	30	10	30
Instituto Italiano del Marchio di Qualita' (IMQ)	IEMMEQU <HAR>	10	30	50
British Approvals Service for Electric Cables (BASEC)	BASEC <HAR>	10	10	30
N.V. KEMA	KEMA-KEUR <HAR>	10	30	30
SEMKO AB Svenska Elektriska Materielkontrollanstalter	SEMKO <HAR>	10	10	50

Österreichischer Verband für Elektrotechnik (ÖVE)	⟨ÖVE⟩	⟨HAR⟩	30	10	50
Danmarks Elektriske Materialkontroll (DEMKO)	⟨DEMKO⟩	⟨HAR⟩	30	10	30
National Standards Authority of Ireland (NSAI)	⟨NSAI⟩	⟨HAR⟩	30	30	50
Norges Elektriske Materiellkontroll (NEMKO)	NEMKO	⟨HAR⟩	10	10	70
Asociacion Electrotecnica Y Electronica Espanola (AEE)	⟨UNED⟩	⟨HAR⟩	30	10	70
Hellenic Organization for Standardization (ELOT)	ELOT	⟨HAR⟩	30	30	70
Instituto Portages da Qualidade (IPQ)	np	⟨HAR⟩	10	10	90
Schweizerischer Elektro Technischer Verein (SEV)	SEV	⟨HAR⟩	10	30	90
Elektriska Inspektoratet	SETI	⟨HAR⟩	10	30	90

Underwriters Laboratories Inc. (UL)

SV, SVT, SJ or SJT, 3 X 18AWG

Canadian Standards Association (CSA)

SV, SVT, SJ or SJT, 3 X 18AWG

MEMO

MEMO

MEMO

OLYMPUS®

OLYMPUS CORPORATION

Shinjuku Monolith, 3-1, Nishi Shinjuku 2-chome, Shinjuku-ku, Tokyo, Japan

OLYMPUS EUROPA HOLDING GMBH

Wendenstrasse 14-18, 20097 Hamburg, Germany

OLYMPUS AMERICA INC.

3500 Corporate Parkway, Center Valley, Pennsylvania 18034-0610, U.S.A.

OLYMPUS SINGAPORE PTE LTD.

491B River Valley Road, #12-01/04 Valley Point Office Tower, Singapore 248373

OLYMPUS AUSTRALIA PTY. LTD.

31 Gilby Road, Mount Waverley, VIC., 3149, Melbourne, Australia

OLYMPUS LATIN AMERICA, INC.

5301 Blue Lagoon Drive, Suite 290 Miami, FL 33126, U.S.A.

