

OLYMPUS®



ZUIKO DIGITAL
ED35-100mm f2.0

EN Instructions

For customers in Europe



The "CE" mark indicates that this product complies with the European requirements for safety, health, environment and customer protection. CE-mark products are for sale in Europe.

For customers in USA

FCC Notice

This device complies with part 15 of the FCC rules. Operation is subject to the following two conditions: (1) This device may not cause harmful interference, and (2) this device must accept any interference received, including interference that may cause undesired operation.

Any unauthorized changes or modifications to this equipment would void the user's authority to operate.

For customers in CANADA

This Class B digital apparatus complies with Canadian ICES-003.

Checking the Package Contents

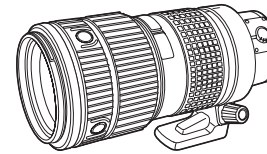

Lens main body

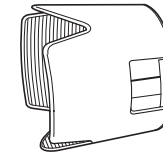

Lens Hood LH-82

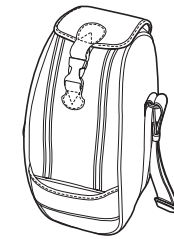

Lens Case LSH-1326

Features

- The ED35-100mm f2.0 is a lens with high imaging capability, designed exclusively for use with Olympus FOUR THIRDS single-lens-reflex digital cameras.
- Dustproof and drip-proof construction.
- Telephoto zoom lens equivalent to a 70-200 mm lens on a 35 mm film camera.
- High-image-quality, 18-group, 21-element F2.0 lens system that includes one Super ED lens and four ED elements (Extra-low Dispersion glass lenses).
- Can be used in combination with the optional EC-14 teleconverter. Set the aperture at composite f-stop of f4 or more.
- Can be used in combination with the optional EX-25 extension tube under the following conditions:

Focal Distance	Focusing Method	Shooting Range	Magnification (Equivalent 35mm values are shown in parentheses)
35 mm		Not usable because focusing is impossible.	
60 mm	MF	30.9 cm – 32.1 cm (1.03 ft – 1.07 ft)	0.40x – 0.42x (0.80x – 0.84x)
100 mm	MF	52.9 cm – 54.4 cm (1.76 ft – 1.81 ft)	0.25x – 0.30x (0.50x – 0.60x)

This lens cannot be used in combination with the Olympus Macro Flash System.

Nomenclature

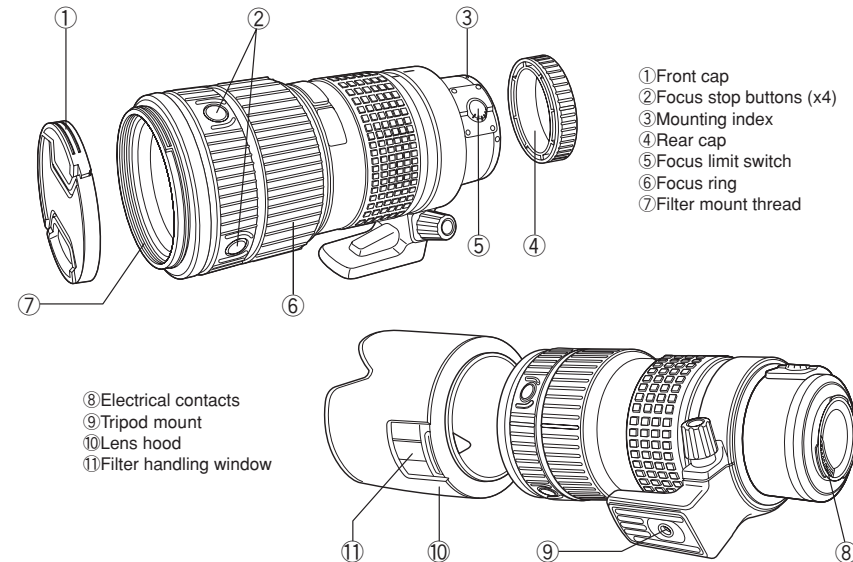

Contents

• Features	10
• Checking the Package Contents	11
• Nomenclature	11
• Lens Case (Provided)	11
• Attaching the Hood	12
• Storing the Hood	12
• Using the Filter Handling Window	12
• Attaching and Detaching the Tripod Mount	13
• Focus Limit Switch	13
• Focus Stop Buttons	13
• Shooting Cautions	13
• Precautions: Be Sure to Read the Following	14
• Main Specifications	15

Lens Case (Provided)

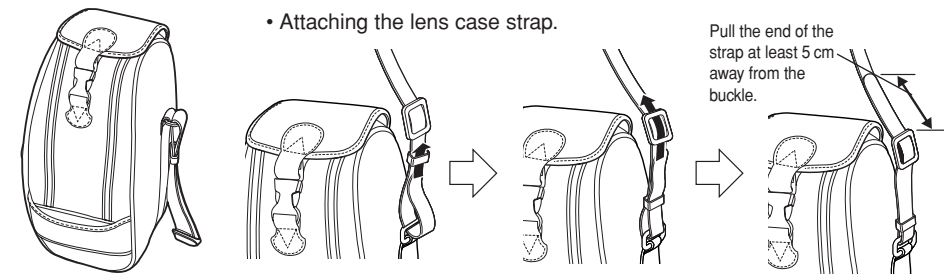

Attaching the Hood

- Turn it until it clicks.

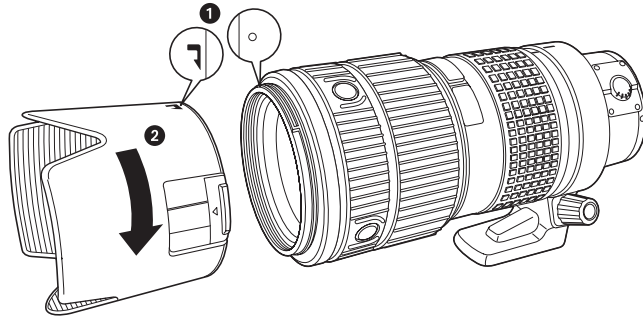

Storing the Hood

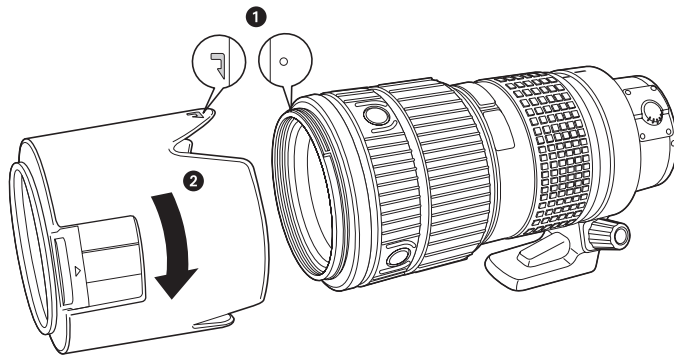

Using the Filter handling window

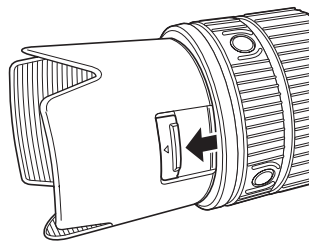

- This opening provides access to the circular polarizing filter without having to remove the hood. Open the sliding lid and manipulate the circular polarizing filter as required.
- Be sure to close the sliding lid before you start shooting.

Attaching and Detaching the Tripod Mount

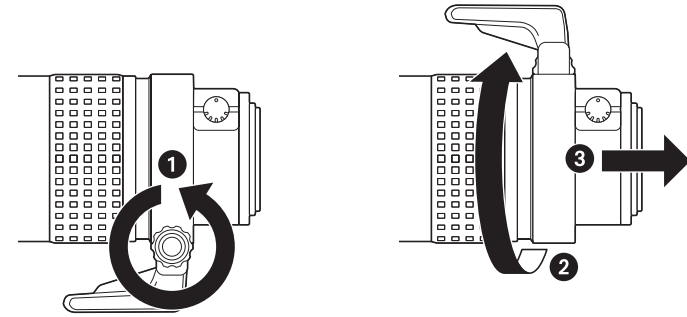

Focus Limit Switch

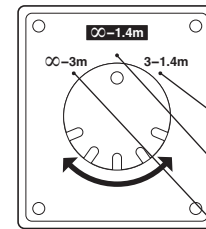

This switch limits the autofocus range to speed up focusing in each range.

Select the optimum mode according to the shooting distance.

- Close-up shooting : Autofocus is performed between 3 meters (9.8 ft) and 1.4 meters (4.6 ft).
- Normal shooting : Autofocus is performed from ∞ (infinity) to 1.4 meters (4.6 ft).
- Distant shooting : Autofocus is performed from ∞ (infinity) to 3 meters (9.8 ft).

Focus Stop Buttons

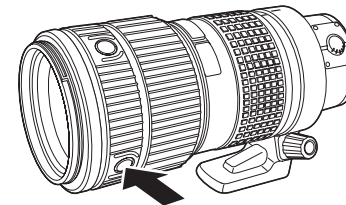

- By holding down one of the focus stop buttons, you can deactivate autofocus operation and fix focus at the point where the button was pressed.
- Four buttons are provided. All have the same effect.

Shooting Cautions

- Be sure to attach the hood when shooting against the light.
- When two or more filters are used or a thick filter is used, part of the picture may be cut off or obscured.

Precautions: Be Sure to Read the Following

⚠ Warnings: Safety Precautions



Do not view the sun through the lens.

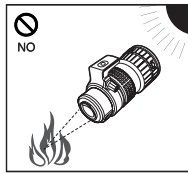

Do not leave the lens without the cap. If solar light is converged through the lens, a fire may result.

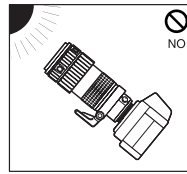

Do not point the camera lens at the sun. Sunlight will converge in the lens and focus inside the camera, possibly causing a malfunction or fire.

Handling Precautions

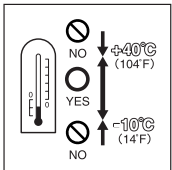

Working temperature range

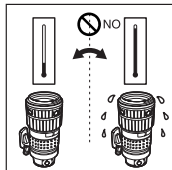

Abrupt temperature changes

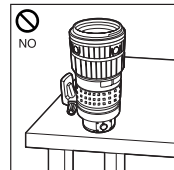

Do not put the lens with its contacts facing down.

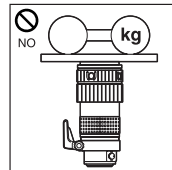

Too much pressure



Do not touch the lens.

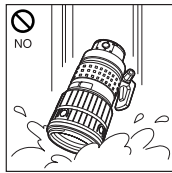

Submergence

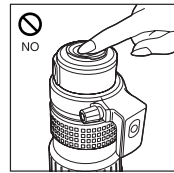

Do not touch the contacts.

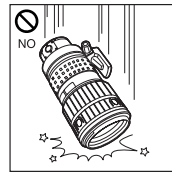

Do not drop

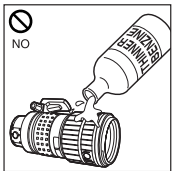

Organic solvents



Excessive moisture

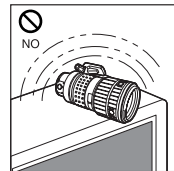

Magnetism

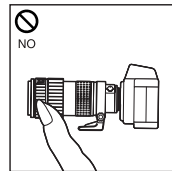

Do not hold the camera by the section of the lens extruded by the focusing operation.

Storage Precautions

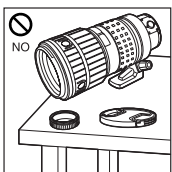

Cap the lens when it is not used.

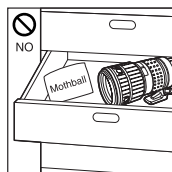

Moth repellents

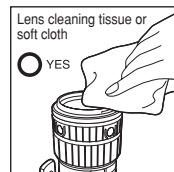

Lens cleaning

Main Specifications

Mount	: Four Thirds mount
Focal distance	: 35-100 mm
Max. aperture	: f2.0
Image angle	: 34°-12°
Lens configuration	: 21 elements in 18 groups Multi-layer coating (partial single-layer coating)
Iris control	: f2.0 to f22
Shooting range	: 1.4 m (4.6 ft) to ∞ (infinity)
Focus adjustment	: AF/MF switching
Weight	: 1650 g (58.2 oz) (w/o tripod mount. Tripod mount weight: 150 g (5.3 oz))
Dimensions	: Max. dia. ø96.5 mm (3.8 in) x Overall length 213.5 mm (8.4 in)
Lens hood mount	: Bayonet
Filter mount thread diameter	: 77 mm (3.0 in)

- Design and specifications are subject to change without any notice or obligation on the part of the manufacturer.

Lens configuration diagram

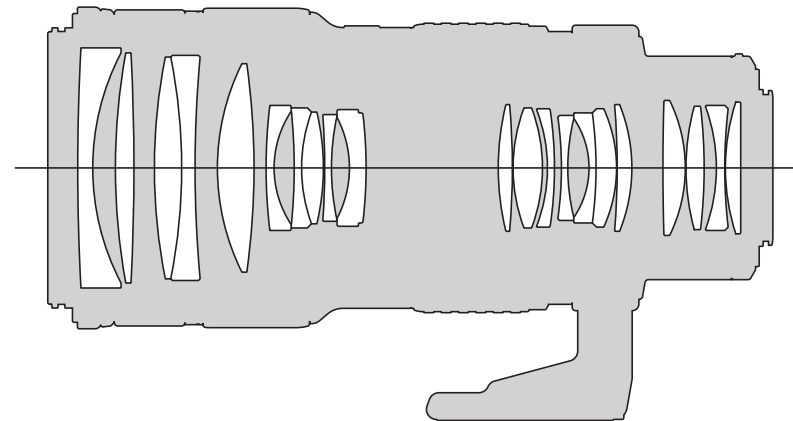

● Technical Support (USA)

24/7 online automated help: <http://www.olympusamerica.com/E1>

Phone customer : Tel.1-800-260-1625 (Toll-free)

Our phone customer support is available from 8 am to
10 pm (Monday to Friday) ET

E-Mail : e-slrpro@olympusamerica.com

● European technical Customer Support

Please visit our homepage <http://www.olympus-europa.com>

or call NUMBER : Tel.00800-67 10 83 00 (Toll-free)

+49 1805-67 10 83 or +49 40-23 77 38 99 (Charged)