

PENTAX

A RICOH COMPANY

Digital Camera

PENTAX Q7

Operating Manual

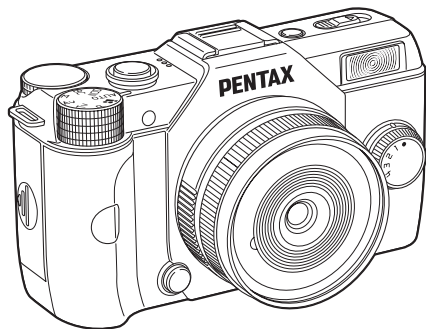

Introduction **1**

Getting Started **2**

Shooting **3**

Playback **4**

Settings **5**

Appendix **6**

To ensure the best performance from your camera, please read the Operating Manual before using the camera.

Checking the Contents of the Package



Hot shoe cover Fk
(Installed on camera)



Q body mount cover
(Installed on camera)

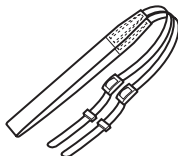

Strap
O-ST131

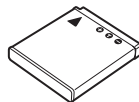

Rechargeable lithium-ion
battery D-LI68

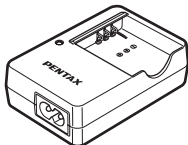

Battery charger
D-BC68P



AC plug cord

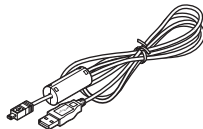

USB cable
I-USB7

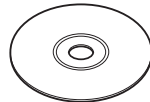

Software (CD-ROM)
S-SW133

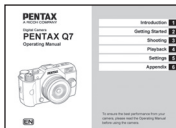

Operating Manual
(this manual)

Lenses that can be used with the PENTAX Q7

Lenses that can be used with the camera are Q-mount lenses. A K-mount lens can be attached to the camera with the use of the optional Adapter Q for K Mount Lens. (p.73)

Introducing the PENTAX Q7

1

Getting Started

2

Taking Pictures

3

Playback Functions

4

Changing the Settings

5

Appendix

6

How to Use This Manual

1

Introducing the PENTAX Q7 p.7

Gives you an overview of the PENTAX Q7.
Read this and get to know your Q7!

- Names and Functions of the Working Parts** p.7
- How to Change Function Settings** p.13
- Menu List** p.15

2

Getting Started p.21

Explains how to get your PENTAX Q7 ready for shooting as well as basic operations.

- Attaching a Lens** p.21
- Using the Battery and Charger** p.22
- Inserting a Memory Card** p.24
- Initial Settings** p.25
- Basic Shooting Operation** p.27
- Reviewing Images** p.28

3

Taking Pictures p.29

Once you've confirmed that the camera works properly, try out the camera and take lots of pictures!

- Selecting the Appropriate Capture Mode** ... p.29
- Setting the Exposure** p.33
- Using the Built-in Flash** p.34
- Focusing** p.36
- Setting the Drive Mode** p.38
- Setting a File Format** p.43
- Adjusting the Color and Brightness of Images** p.43
- Controlling the Image Finishing Touch** p.46

4

Playback Functions p.50

Explains various operations for playing back and editing images.

- Playback Mode Palette Items** p.50
- Changing the Playback Method** p.51
- Connecting the Camera to a Computer** ... p.55
- Editing and Processing Images** p.56

5

Changing the Settings..... p.62

Explains how to change other settings.

- Camera Settings** p.62
- File Management Settings** p.65

6

Appendix..... p.69

Provides various resources.

- Restrictions on Each Capture Mode** p.69
- Functions Available with Various Lenses** p.72
- Functions when Using an External Flash** p.74
- Troubleshooting** p.75
- Main Specifications** p.78
- Index** p.85
- For Using Your Camera Safely** p.89
- Care to be Taken During Handling** p.90
- WARRANTY POLICY** p.93

Contents

How to Use This Manual	2
Introducing the PENTAX Q7	7
Names and Functions of the Working Parts	7
Buttons and Dials	8
Monitor Display	9
How to Change Function Settings	13
Using the Direct Keys	13
Using the Control Panel	13
Using the Menus	14
Menu List	14
Rec. Mode Menus	15
Movie Menu	17
Playback Menu	17
Set-up Menu	17
Custom Setting Menus	19
Getting Started	21
Attaching a Lens	21
Using the Battery and Charger	22
Charging the Battery	22
Inserting/Removing the Battery	22
Using the AC Adapter	23
Inserting a Memory Card	24
Initial Settings	25
Turning the Camera On	25
Setting the Display Language	25
Setting the Date and Time	26
Formatting a Memory Card	26

Basic Shooting Operation	27
Reviewing Images	28
Taking Pictures	29
Selecting the Appropriate Capture Mode	29
Scene Modes	29
Blur Control Mode	30
Exposure Modes	31
Movie Mode	32
Setting the Exposure	33
Sensitivity	33
AE Metering	34
Using the Built-in Flash	34
Focusing	36
Focus Method	36
Setting the Autofocus Method	36
Adjusting the Focus Manually (Manual Focus)	37
Setting the Drive Mode	38
Continuous Shooting	39
Self-timer Shooting	40
Remote Control Shooting	40
Exposure Bracketing	41
Multi-exposure	41
Interval Shooting	42
Interval Movie Record	42
Setting a File Format	43
Still Pictures	43
Movies	43

Adjusting the Color and Brightness of Images	43	Changing the Settings	62
White Balance	43	Camera Settings	62
Adjusting Brightness	45	Setting the  Functions	62
Controlling the Image Finishing Touch	46	Saving the Settings of a Captured Image	63
Custom Image	46	Displaying the Local Date and Time	
Digital Filter	47	of the Specified City	64
Saving Frequently Used Functions		Selecting Settings to Save in the Camera	65
to the Quick Dial	48	File Management Settings	65
Playback Functions	50	Protecting Images from Deletion (Protect)	65
Playback Mode Palette Items	50	Selecting the Folder/File Number Settings	66
Changing the Playback Method	51	Transferring Images via Wireless LAN	67
Displaying Multiple Images	51	Setting Print Information (DPOF)	68
Displaying Images by Folder	52	Appendix.....	69
Displaying Images by Shooting Date	52	Restrictions on Each Capture Mode	69
Playing Back Images Continuously (Slideshow)	53	Restrictions on the Combinations of Special Functions ...	71
Displaying Rotated Images	53	Functions Available with Various Lenses	72
Connecting the Camera to an AV Device	54	Using a K-Mount Lens	73
Connecting the Camera to a Computer	55	Functions when Using an External Flash	74
Editing and Processing Images	56	Troubleshooting	75
Changing the Image Size	56	Error Messages	76
Removing the Red-eye Effect	57	Main Specifications	78
Processes images with Digital Filters	57	Operating Environment for USB Connection	
Creating a Composite Image (Index)	58	and Provided Software	83
Editing Movies	59	Index	85
RAW Development	60	For Using Your Camera Safely	89
		Care to be Taken During Handling	90
		WARRANTY POLICY	93

Regarding copyrights

Images taken with this camera that are for anything other than personal enjoyment cannot be used without permission according to the rights as specified in the Copyright Act. Please take care, as there are cases where limitations are placed on taking pictures even for personal enjoyment during demonstrations, performances or of items on display. Images taken with the purpose of obtaining copyrights also cannot be used outside the scope of use of the copyright as laid out in the Copyright Act, and care should be taken here also.

Regarding User Registration

In order to better serve you, we request that you complete the user registration, which can be found on the CD-ROM supplied with the camera or on our website. Thank you for your cooperation.

Names and Functions of the Working Parts

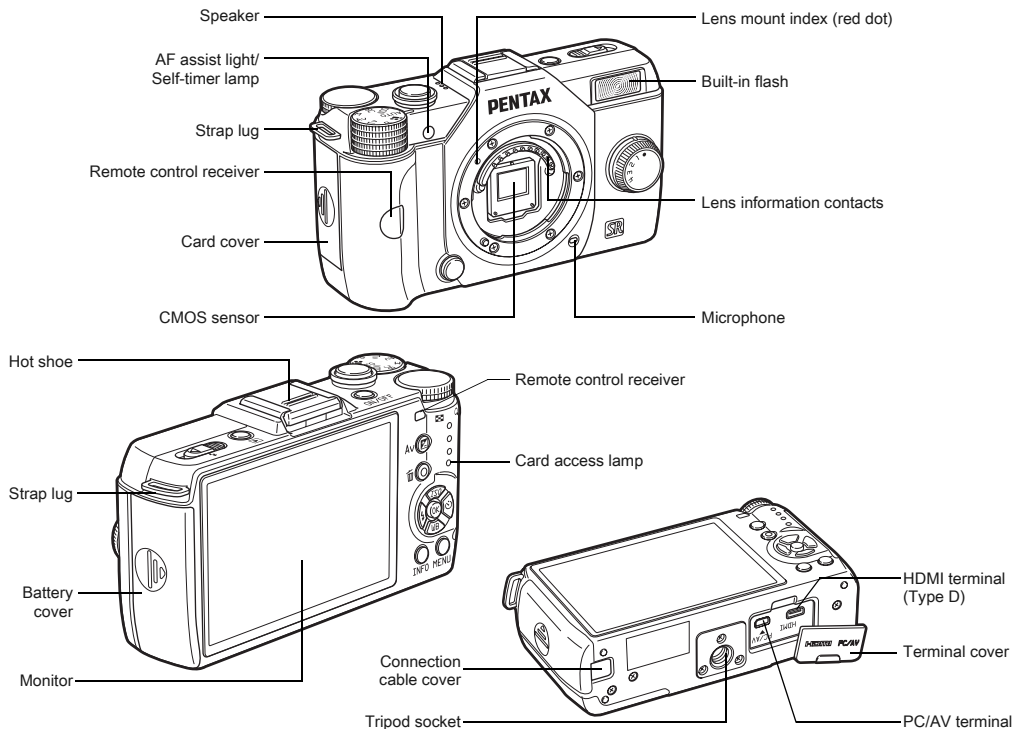

Buttons and Dials

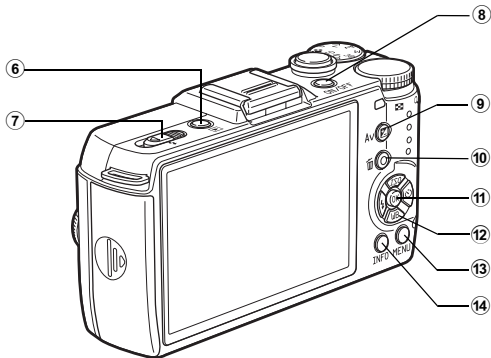
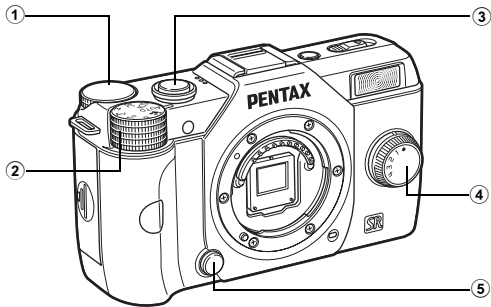

- ① **E-dial** 

Sets the shutter speed, aperture, and exposure compensation values. (p.31)
 You can change the settings when the control panel is displayed. (p.13)
 You can change the menu tabs when a menu screen is displayed. (p.14)
 In playback mode, use this to magnify an image or display multiple images at the same time. (p.51)
- ② **Mode dial**

Changes the capture mode. (p.27)
- ③ **Shutter release button**

Press to capture images. (p.28)
 In playback mode, press halfway to switch to capture mode.
- ④ **Quick dial**

You can save your preferred shooting settings and then retrieve them easily later on. (p.48)
- ⑤ **Lens unlock button**

Press to detach a lens. (p.21)
- ⑥ **Playback button** 

Switches to playback mode. (p.28) Press the button again to switch to capture mode.
- ⑦ **Flash pop-up switch**

Slide to pop up the built-in flash. (p.35)
- ⑧ **Power switch**

Press to turn the camera on and off. (p.25)
- ⑨ **EV compensation button** 

Press to change the exposure compensation and aperture values. (p.31)
 In playback mode, the JPEG data remaining in the buffer memory is saved in RAW format. (p.28)

10 Green/Delete button (O/⏏)

Resets the values being adjusted. Also, you can assign a function to this button. (p.62)

Press to delete images during playback. (p.28)

11 OK button (OK)

When the control panel or a menu is displayed, press this button to confirm the selected item.

12 Four-way controller (▲▼◀▶)

Displays the Sensitivity/White Balance/Flash Mode/Drive Mode setup menu. (p.13)

When the control panel or a menu is displayed, use this to move the cursor or change the item to set.

Press ▼ during playback to display the playback mode palette. (p.50)

13 MENU button (MENU)

Displays a menu. Press this button while the menu is displayed to return to the previous screen. (p.14)

14 INFO button (INFO)

Changes the style of the display on the monitor. (p.9, p.11)

Monitor Display**Capture Mode**

When the camera enters capture mode, the subject and the current shooting function settings are displayed on the monitor. This state is referred to as "standby mode". Press **INFO** in standby mode to display the "control panel" and change settings. (p.13) If you press **INFO** while the control panel is displayed, you can change the type of information displayed in standby mode. (p.11)

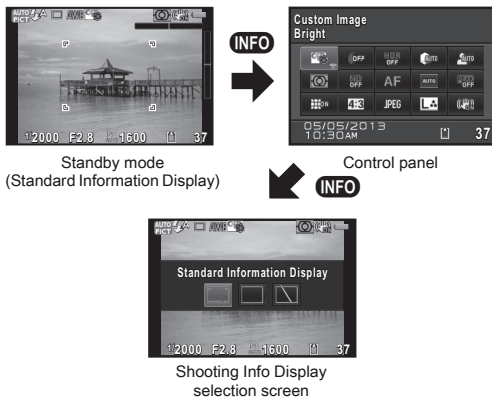

Standby Mode

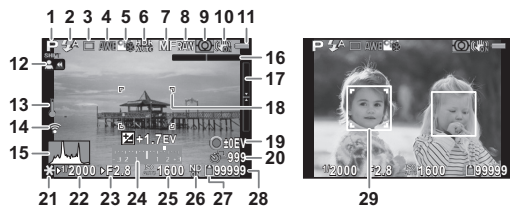

- | | |
|--|---|
| 1 Capture mode (p.29) | 17 Electronic Level (vertical) |
| 2 Flash Mode (p.34) | 18 AF frame |
| 3 Drive Mode (p.38) | 19 Reset exposure compensation value |
| 4 White Balance (p.43) | 20 Interval Shooting/ Multi-exposure (p.41)/ Smart Effect (p.49) |
| 5 Custom Image (p.46) | 21 AE Lock |
| 6 HDR Capture (p.45)/ Digital Filter (p.47) | 22 Shutter speed |
| 7 MF mode | 23 Aperture value |
| 8 File Format | 24 EV bar scale |
| 9 AE Metering (p.34) | 25 Sensitivity (p.33) |
| 10 Shake Reduction/ Movie SR | 26 ND Filter |
| 11 Battery level | 27 Memory card |
| 12 Turning the focus ring in MF mode (p.37) | 28 Image storage capacity |
| 13 Temperature warning | 29 Face detection frame (when [Autofocus Method] is set to [Face Detection]) (p.36) |
| 14 Eye-Fi communication status | |
| 15 Histogram | |
| 16 Electronic Level (horizontal) | |

Memo

- The displayed items vary depending on the current camera setup.
- In [Live View] of the menu, you can change the style of the display in standby mode. (p.16)

Control Panel

mode

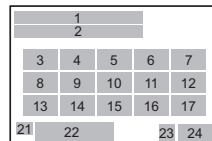

mode

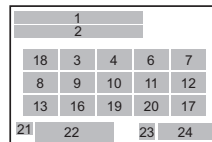

- | | |
|---|----------------------------|
| 1 Function name | 8 AE Metering (p.34) |
| 2 Setting | 9 ND Filter |
| 3 Custom Image (p.46)/ SCN mode (p.29) | 10 Focus Method (p.36) |
| 4 Digital Filter (p.47) | 11 Autofocus Method (p.36) |
| 5 HDR Capture (p.45) | 12 Focus Peaking (p.38) |
| 6 Highlight Correction (p.45) | 13 Distortion Correction |
| 7 Shadow Correction (p.45) | 14 Aspect Ratio (p.43) |
| | 15 File Format (p.43) |

- 16 JPEG Recorded Pixels and Quality Level (p.43)
- 17 Shake Reduction/ Movie SR
- 18 Exposure Setting
- 19 Framerate
- 20 Recording Sound Level
- 21 Destination (p.64)
- 22 Current date and time
- 23 Memory card
- 24 Number of recordable still pictures/movie recordable time

Memo

- Items that can be selected vary depending on the current camera setup.
- If no operations are made within 1 minute while the control panel is displayed, the camera will return to standby mode.
- You can change the display color of the control panel and menus in [LCD Display] of the 1 menu. (p.18)

Shooting Info Display

If you press **INFO** while the control panel is displayed, you can select the type of information displayed in standby mode. Use **◀▶** to select the type and press **OK**.

Standard Information Display	An image and the current shooting function settings are displayed.
No Information Display	Only an image is displayed.
Display Off	Nothing is displayed on the monitor.

Caution

- [Display Off] cannot be selected in mode.

Playback Mode

The captured image and shooting information are displayed in single image display of the playback mode.

Press **INFO** to select the type of information displayed in single image display. Use **◀▶** to select the type and press **OK**.



Single image display
(Standard Information Display)



Playback Info Display
selection screen

Standard Information Display	Captured image, file format, exposure value, and operation guide indicators are displayed.
Detailed Information Display	Detailed information on how and when the image was taken is displayed. (p.12)
Histogram Display	Captured image and brightness histogram are displayed. (p.12) Not available during movie playback.
RGB Histogram Display	Captured image and RGB histogram are displayed. (p.12) Not available during movie playback.
No Information Display	Only the captured image is displayed.

Memo

- The screen selected in Playback Info Display selection screen is displayed in playback mode when the camera is turned off and on again. If [Playback Info Display] is set to [Off] in [Memory] of the 3 menu, the [Standard Information Display] always appears first when the camera is turned on. (p.65)

Detailed Information Display

Still pictures

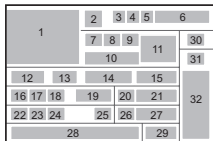

Movies

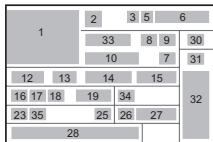

- | | |
|------------------------------------|---|
| 1 Captured image | 13 Aperture value |
| 2 Capture mode (p.29) | 14 Sensitivity (p.33) |
| 3 Transferred via Eye-Fi (p.67) | 15 EV Compensation |
| 4 DPOF setting (p.68) | 16 Highlight Correction (p.45) |
| 5 Protect setting (p.65) | 17 Shadow Correction (p.45) |
| 6 Folder number-File number (p.66) | 18 Distortion Correction |
| 7 Drive Mode (p.38) | 19 Smart Effect (p.49) |
| 8 AE Metering (p.34) | 20 Flash Mode (p.34) |
| 9 Shake Reduction/ Movie SR | 21 Flash Exposure Compensation |
| 10 Lens focal length | 22 File Format (p.43) |
| 11 Focus Method (p.36) | 23 JPEG Recorded Pixels (p.43)/Movie Recorded Pixels (p.43) |

- | | |
|--|--------------------------------|
| 24 JPEG Quality (p.43) | 31 Custom Image setting (p.46) |
| 25 ND Filter | 32 Custom Image parameters |
| 26 White Balance (p.43) | 33 Recording time |
| 27 White Balance fine-tuning | 34 Sound |
| 28 Shooting date and time | 35 Framerate (p.43) |
| 29 Color Space | |
| 30 HDR Capture (p.45)/ Digital Filter (p.47) | |

Histogram Display/RGB Histogram Display

Use ▲▼ to switch between the Histogram Display and RGB Histogram Display.

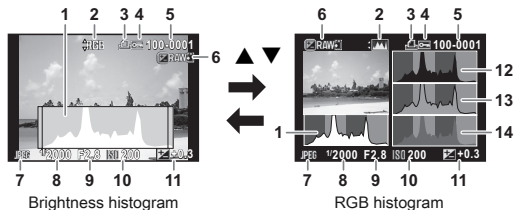

- | | |
|--|--------------------|
| 1 Histogram (Brightness) | 7 File Format |
| 2 Switch RGB histogram/ Brightness histogram | 8 Shutter speed |
| 3 DPOF setting | 9 Aperture value |
| 4 Protect setting | 10 Sensitivity |
| 5 Folder number-File number | 11 EV Compensation |
| 6 Save RAW Data | 12 Histogram (R) |
| | 13 Histogram (G) |
| | 14 Histogram (B) |

How to Change Function Settings

The camera functions and their settings can be selected and changed by using the following ways.

Direct keys	Press ▲▼◀▶ in standby mode.
Control panel	Press INFO in standby mode. (indicated with the  mark in this manual)
Menus	Press MENU .

Using the Direct Keys

▲	Sensitivity	p.33
▼	White Balance	p.43
◀	Flash Mode	p.34
▶	Drive Mode	p.38

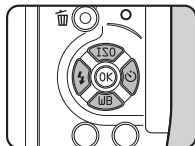

Using the Control Panel

INFO

You can set frequently used shooting functions. Press **INFO** in standby mode.

Use **▲▼◀▶** to select an item.

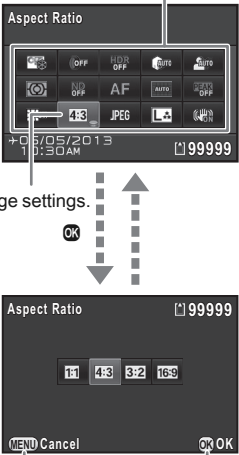

Use **OK** to change settings.

Press **MENU** to cancel setting operation.

Press **OK** to confirm the selected item and return to the control panel.

Most functions are set from the menu. Functions that can be set on the control panel can also be set from the menus.

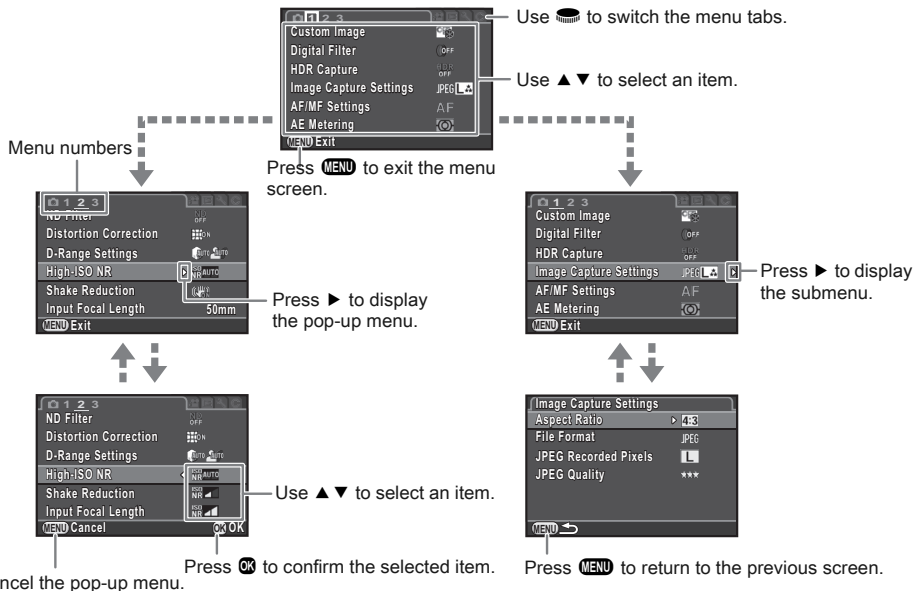





Memo

- In capture mode, the 1 menu is always displayed first when **MENU** is pressed. To display the menu tab selected the last time first, set in [15. Save Menu Location] of the 3 menu.
- Settings are returned to their default values with [Reset] of the 3 menu (excluding some functions).



Rec. Mode Menus

Menu	Item	Function	Default Setting	Page	
	Custom Image *1	Sets the image finishing touch such as color and contrast before shooting an image.	Bright	p.46	
	Digital Filter *1	Applies a digital filter effect when taking pictures.	No Filter	p.47	
	HDR Capture *1	Enables capturing images with high dynamic range.	Off	p.45	
	Image Capture Settings	Aspect Ratio *1	Sets the horizontal and vertical ratio of images.	4:3	p.43
		File Format *1	Sets the file format of images.	JPEG	
		JPEG Recorded Pixels *1	Sets the recording size of images saved in JPEG format.	L	
		JPEG Quality *1	Sets the quality of images saved in JPEG format.	★★★	
	AF/MF Settings	Focus Method *1	Selects the autofocus or manual focus mode.	AF	p.36
		Autofocus Method *1	Selects the autofocus method in AF mode.	Multiple AF Points	p.36
		AF Assist Light	Sets whether to use the assist light when autofocusing in dark locations.	On	p.36
		MF Autozoom	Magnifies the monitor display and makes it easier to focus on the subject.	Off	p.37
		Focus Peaking *1	Emphasizes the outline of the subject in focus and makes it easier to check the focus.	Off	p.38
	AE Metering *1	Selects the part of the sensor to use for measuring brightness and determining exposure.	Multi-segment	p.34	

Menu	Item	Function	Default Setting	Page	
 2	ND Filter *1	Sets whether to use the ND filter built-in to the lens.	Off	-	
	Distortion Correction *1	Reduces distortions occurring due to lens properties.	On	-	
	D-Range Settings *1	Expands the dynamic range and prevents bright and dark areas from occurring.	Auto	p.45	
	High-ISO NR	Sets the Noise Reduction setting when shooting with a high ISO sensitivity.	Auto	p.34	
	Shake Reduction *1	Activates the Shake Reduction function.	On	-	
	Input Focal Length	Sets the focal length when using a lens for which focal length information cannot be obtained.	0.0 mm	p.73	
 3	Live View	Electronic Level	Displays the camera angle (horizontal and vertical) in standby mode.	On	p.10
		Grid Display	Displays the grid in standby mode.	Off	
		Histogram Display	Displays the histogram in standby mode.	Off	
		Highlight Alert	Bright (overexposed) areas blink red in standby mode.	Off	
	Instant Review	Display Time	Sets the Instant Review display time.	1sec.	p.28
		Zoom Instant Review	Sets whether to display magnified image during Instant Review.	Off	
		Save RAW Data	Sets whether to save the RAW image during Instant Review.	On	
		Delete	Sets whether to delete the image during Instant Review.	On	
		Histogram Display	Displays the histogram during Instant Review.	Off	
		Highlight Alert	Bright (overexposed) areas blink red during Instant Review.	Off	
	Quick Dial	Assigns functions to the quick dial.	Smart Effect	p.48	
	Green Button	Green Button	Assigns a function to  .	Green Button	p.62
		Action in M/TAv Mode	Sets the action for when  is pressed in M / TAv mode.	P LINE	p.63
		E-dial in Program	Sets the value to change when  is turned in P mode.	P SHIFT	p.62
Memory		Determines which settings to save when the power is turned off.	All On except Focus Position/ Digital Filter/ HDR Capture	p.65	

*1 The functions can also be set from the control panel.

Movie Menu

Menu	Item	Function	Default Setting	Page
 1	Exposure Setting *1	Sets whether to adjust the shutter speed and aperture value manually.	Auto	p.33
	Digital Filter *1	Applies a digital filter effect when taking pictures.	No Filter	p.47
	Movie Capture Settings *1	Sets the number of recorded pixels and framerate of the movie.	 /30 fps	p.43
	Recording Sound Level *1	Sets the volume level for recording.	Volume level 3	-
	Movie SR *1	Activates the Movie Shake Reduction function.	On	-

*1 Can also be set from the control panel.

Playback Menu





Menu	Item	Function	Default Setting	Page	
 1	Slideshow	Display Duration	Sets an image display interval.	3sec.	p.53
		Screen Effect	Sets a transition effect when the next image is displayed.	Off	
		Repeat Playback	Starts the slideshow again from the beginning after the last image is displayed.	Off	
		Auto Movie Playback	Plays back movies during the slideshow.	On	
	Quick Zoom	Sets the initial magnification when magnifying images.	Off	-	
	Highlight Alert	Bright (overexposed) portions blink red in Standard Information Display or Histogram Display in playback mode.	Off	-	
	Auto Image Rotation	Images are rotated when playing back images captured with the camera held vertically or images for which the rotation information has been changed.	On	p.53	
	Delete All Images	Deletes all saved images at once.	-	-	

Set-up Menus

1

Introduction

Menu	Item	Function	Default Setting	Page	
1	Language/言語	Changes the display language.	English	p.25	
	Date Adjustment	Sets the date and time or display format.	01/01/2013	p.26	
	World Time	Switches the displayed date and time to that of your hometown or a specified city.	Hometown	p.64	
	Sound Effects	Switches the operation sound on/off and changes the volume for In-focus, AE-L, Self-timer, Remote Control, One Push File Format and Shutter Sound.	Volume 3 Shutter Sound: 1 Others: On	-	
	LCD Display	Guide Display	Sets whether to display the operation guides when the capture mode is changed.	On	p.11
		Display Color	Sets the display color of the control panel and menus.	1	
		LCD Display Settings	Adjusts the brightness and the color of the monitor.	0	-
2	Flicker Reduction	Cuts down on screen flicker by setting the power frequency.	50Hz	-	
	Interface Options	Video Out	Sets the output format when connecting to an AV device with a video input terminal.	-	p.54
		HDMI Out	Sets the output format when connecting to an AV device with an HDMI input terminal.	Auto	p.54
		USB Connection	Sets the USB connection mode when connecting to a computer.	MSC	p.75
		Folder Name	Sets the naming system for folders to store images.	Date	p.66
		Create New Folder	Creates a new folder on the memory card.	-	p.66
	File No.	Sequential Numbering	Sets whether to continue the sequential numbering for the file name even if a new folder is created.	On	p.66
		Reset File Number	Resets the file number and starts numbering from 0001 again.	-	
		Eye-Fi	Sets the camera action for when an Eye-Fi card is used.	Off	p.67

Menu	Item	Function	Default Setting	Page
3	Power Saving	Enables saving battery power by setting the display to dim automatically if no operations are made within 5 seconds.	On	-
	Auto Power Off	Sets the time until the camera turns off automatically if no operations are made for a certain period of time.	1 min.	p.25
	Reset	Resets the settings of the direct keys and for the items of the  menu,  menu,  menu,  menu, control panel, and playback mode palette.	-	p.14
4	Pixel Mapping	Maps out and corrects any defective pixels on the CMOS sensor.	-	p.76
	Dust Removal	Cleans the CMOS sensor by shaking it.	-	p.76
	Format	Formats a memory card.	-	p.26
	Firmware Info/Options	Displays the camera's firmware version. If an update file is saved on your card, you can run the update.	-	-

Custom Setting Menus

Menu	Item	Function	Default Setting	Page
C1	1. Lens Shutter Options	Sets whether to use the lens shutter and/or the electronic shutter.	Lens shutter only	p.72
	2. Sensitivity Steps	Sets the adjustment steps for ISO sensitivity.	1 EV Step	p.34
	3. AE-L with AF Locked	Sets whether to lock the exposure value when the focus is locked.	Off	-
	4. Link AE and AF Point	Sets whether to link the exposure and AF point in the focusing area during multi-segment metering.	Off	p.34
	5. Bracketing Order	Sets the order for Exposure Bracketing shooting.	0 - +	p.41
	6. WB When Using Flash	Sets the white balance setting when using flash.	Auto White Balance	p.44

Menu	Item	Function	Default Setting	Page
C2	7. AWB in Tungsten Light	Sets the tungsten light color tone when the white balance is set to AWB (Auto White Balance).	Subtle Correction	-
	8. AF Release Options	Sets the action priority for when the shutter release button is fully pressed in AF mode.	Focus-priority	p.36
	9. AF with Remote Control	Sets whether to use autofocus when shooting with a remote control unit.	Off	p.40
	10. Focus Ring in AF Mode	Disables the focus ring operation during AF mode.	Enable	p.36
	11. Flash When Retracted	Sets whether to discharge the built-in flash when retracted.	Discharge Flash	p.35
	12. Release While Charging	Sets whether to release the shutter while the built-in flash is charging.	Off	p.35
C3	13. Color Space	Sets the color space to use.	sRGB	-
	14. Save Rotation Info	Sets whether to save rotation information when shooting.	On	p.53
	15. Save Menu Location	The last menu tab displayed on the monitor is saved, and it is displayed again the next time MENU is pressed.	Reset Menu Location	p.14
	16. Auto SR Off	Automatically turns off the Shake Reduction function when Self-timer or Remote Control is set.	Enable Auto SR Off	p.39
	Reset Custom Functions	Resets all the settings in the C 1-3 menus to the defaults.	-	-

Attaching a Lens

1 Make sure that the camera is turned off.

2 Remove the body mount cover (①) and lens mount cover (②).

After removing the cover, be sure to put the lens down with the lens mount side facing upward.

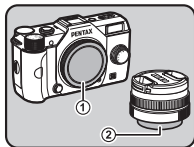

3 Align the lens mount index (red dots: ③) on the camera and the lens, and secure by turning the lens clockwise until it clicks.

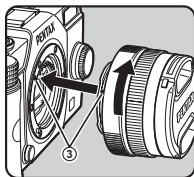

To remove the lens

Attach the lens cap → turn the lens counterclockwise while pushing the lens unlock button (④).

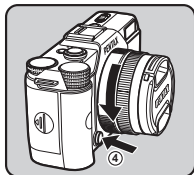

⚠ Caution

- If the lens is removed while the power is on, the shutter release button will be locked. Do not attach or remove the lens while the power is on.

- When attaching or removing the lens, choose an environment that is relatively free of dirt and dust.
- Keep the body mount cover on the camera when a lens is not attached.
- Be sure to attach the lens mount cover and lens cap to the lens after removing it from the camera.
- Do not insert your fingers inside the lens mount of the camera or touch the CMOS sensor.
- The camera body and lens mount incorporate lens information contacts. Dirt, dust, or corrosion may damage the electrical system. Please contact your nearest service center for professional cleaning.
- We assume no responsibility nor liability for accidents, damages and malfunctions resulting from the use of lenses made by other manufacturers.

Using the Battery and Charger

Use the battery D-LI68 and battery charger D-BC68P exclusively developed for this camera.

Charging the Battery

1 Connect the AC plug cord to the battery charger.

2 Plug the AC plug cord into the power outlet.

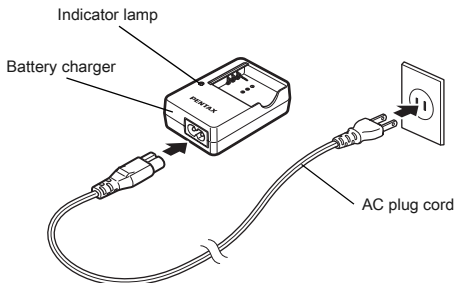

3 Face the ▲ mark on the battery up, and insert it into the battery charger.

The indicator lamp is lit while charging and turns off when the battery is fully charged.

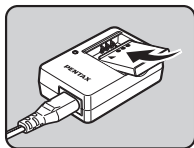

Caution

- Do not use the battery charger D-BC68P to charge batteries other than D-LI68. Charging other batteries may cause damage or heating.
- Replace the battery with a new one in the following cases:
 - If the indicator lamp blinks or does not light after the battery is inserted correctly
 - If the battery starts to run down more quickly even after being charged (the battery may have reached the end of its service life)

Memo

- The maximum charging time is approximately 115 minutes (it depends on temperature and remaining battery power). Charge in a location where the temperature is between 0°C and 40°C (32°F and 104°F).

Inserting/Removing the Battery

Caution

- Insert the battery correctly. If the battery is inserted incorrectly, it may not be removed.
- Wipe the electrodes of the battery with a soft dry cloth before inserting.
- Do not open the battery cover or remove the battery while the power is on.
- Be careful as the camera or battery may become hot when the camera is used continuously for a long period of time.
- Remove the battery when you will not use the camera for a long time. The battery may leak and damage the camera if left installed during prolonged periods of non-use. If the removed battery will not be used for six months or longer, charge the battery for about 30 minutes before storing it. Be sure to recharge the battery every six to twelve months.
- Store the battery in a location where the temperature will remain at or below room temperature. Avoid locations with high temperatures.

- The date and time may be reset if you leave the battery out of the camera for long periods of time. If this happens, set the current date and time.

1 Slide the battery cover in the direction of ①.

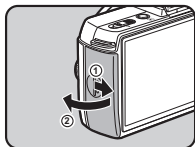

2 Insert the battery until it locks into place with the ▲ mark facing toward the lens.

To remove the battery, push the battery lock lever in the direction of ③.

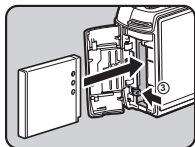

3 Close the battery cover, and slide it in the direction of ⑤.

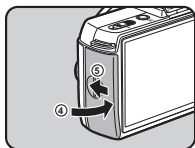

Memo

- The battery level may not be displayed properly if the camera is used at low temperatures or when performing continuous shooting for a long time.
- Battery performance temporarily decreases as the temperature decreases. When using the camera in cold climates, have extra batteries at hand and keep them warm

in your pocket. Battery performance will return to normal when returned to room temperature.

- Have extra batteries ready when traveling overseas, or taking a lot of pictures.

Using the AC Adapter

We recommend the use of the AC adapter kit K-AC115 (optional) when using the monitor for a long time or when connecting the camera to a computer or AV device.

1 Make sure that the camera is turned off, and open the battery cover.

Remove the battery if it is inserted in the camera.

2 Pull down the connection cable cover (①) on the bottom side of the battery chamber, and insert the DC coupler into the battery chamber.

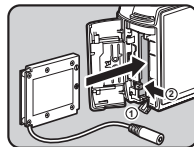

To remove the DC coupler, push the battery lock lever in the direction of ②.

3 Close the battery cover.

Pull out the connection cable from the connection cable cover section.

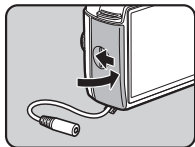
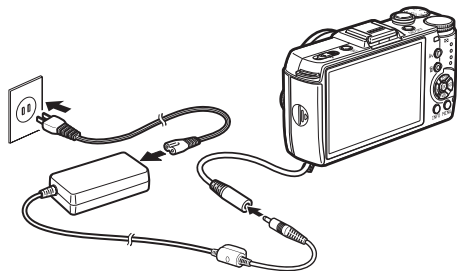
**4 Connect the DC coupler and the AC adapter.****5 Connect the AC adapter to the AC plug cord, and plug the cord into the power outlet.****⚠ Caution**

- Make sure the camera is turned off before connecting or disconnecting the AC adapter.
- Make sure connections are secure between the terminals.
The memory card or data may be corrupted if the connection to the power supply is lost while the card is being accessed.
- After removing the DC coupler, return the connection cable cover to its original position.
- Be sure to read the manual of the AC adapter kit before using the AC adapter.

Inserting a Memory Card

This camera uses a commercially available SD Memory Card, SDHC Memory Card, or SDXC Memory Card. An SD Memory Card with a built-in wireless LAN (Eye-Fi card) can also be used. (In this manual, they are referred to as memory cards.)

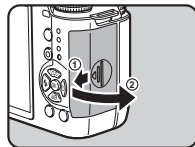
1 Make sure that the camera is turned off.**2 Slide the card cover in the direction of ①.****3 Insert the card all the way with the memory card label facing toward the monitor.**

Push the memory card in once to remove.

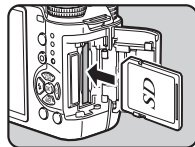

- 4** Close the card cover, and slide it in the direction of ④.

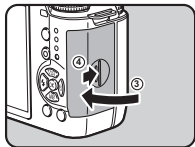

⚠ Caution

- Do not remove the memory card while the card access lamp is lit.
- If the card cover is opened while the power is on, the camera will turn off. Do not open the cover while the camera is in use.
- Use this camera to format (initialize) a memory card that is unused or has been used on other devices. (p.26)
- Use a high-speed memory card when recording movies. If a write speed cannot keep up with a recording speed, the writing may stop during recording.

Initial Settings

Turn the camera on and make the initial settings

Turning the Camera On

1 Press the power switch.

Press the switch again to turn off the camera.
The first time the camera is turned on after purchasing, the [Language/言語] screen appears.

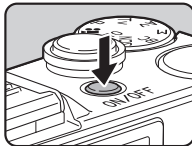

ⓘ Memo

- The power will automatically turn off when you do not perform any operations within a set period of time. (Default setting: 1min.) You can change the setting in [Auto Power Off] of the 3 menu.

Setting the Display Language

1 Use to select the desired language and press .

The [Initial Setting] screen appears in the selected language. Proceed to Step 6 if (Hometown) does not need to be changed.

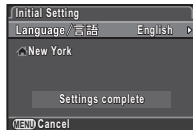

2 Press to move the frame to and press .

The [Hometown] screen appears.

3 Use ◀▶ to select a city.

Use  to change the region. Refer to "List of World Time Cities" (p.82) for cities that can be selected as a hometown.

**4 Press ▼ to select [DST] (daylight saving time), and use ◀▶ to select or .****5 Press OK.**

The camera returns to the [Initial Setting] screen.

6 Press ▼ to select [Settings complete] and press OK.

The [Date Adjustment] screen appears.

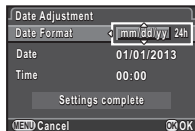
**Setting the Date and Time****1 Press ▶, and use ▲▼ to select the date format.****2 Press ▶, and use ▲▼ to select 24h or 12h.****3 Press OK.**

The frame returns to [Date Format].

4 Press ▼, and then press ▶.

The frame moves to the month if the date format is set to [mm/dd/yy].

5 Use ▲▼ to set the month.

Set the day, year and time in the same manner.

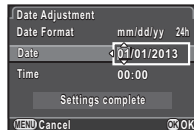
**6 Press ▼ to select [Settings complete] and press OK.**

The camera switches to capture mode and is ready to take a picture.

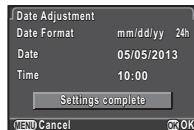
**Memo**

- You can change the language and date and time settings from the  1 menu. (p.18)

Formatting a Memory Card**1 Press MENU.**

The  1 menu appears.

2 Use  to display  4 menu.**3 Use ▲▼ to select [Format] and press ▶.**

The [Format] screen appears.

4 Press ▲ to select [Format] and press OK.

Formatting starts. When formatting is completed, the screen that was displayed before selecting the menu appears again.

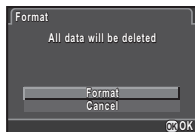

⚠ Caution

- Do not remove the memory card while formatting, or the card may be damaged.
- Formatting deletes all data, both protected and unprotected.

📝 Memo

- When a memory card is formatted, the volume label assigned to the card is "Q7". When this camera is connected to a computer, the memory card is recognized as a removable disk with the name "Q7".

Basic Shooting Operation

Take pictures in **AUTO** mode in which the camera automatically selects the optimal capture mode.

- 1 Remove the front lens cap by pushing the top and bottom portions as indicated in the illustration.

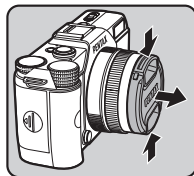

- 2 Turn the camera on.
- 3 Set the mode dial to **AUTO**.

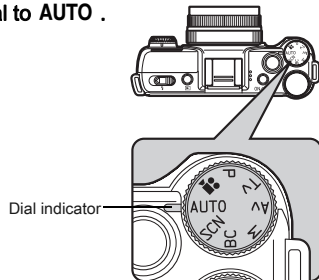

The selected capture mode is displayed on the monitor (Guide Display).



4 View the subject on the monitor.

5 When using a zoom lens, turn the zoom ring to the right or left to adjust the composition of the image.

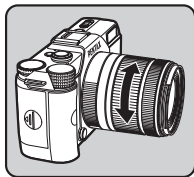

6 Position the subject inside the AF frame and press the shutter release button halfway.

The AF frame turns green and you will hear a beep when the subject comes into focus.



AF frame

🔗 Setting the Sound Effects (p.18)

7 Press the shutter release button fully.

The captured image is displayed on the monitor (Instant Review).

Available operations

🗑 Deletes the image.

📄 Saves the RAW image.

🔗 Setting the display for Instant Review (p.16)

Reviewing Images

Review the captured image on the monitor.

1 Press .

The camera enters playback mode and the most recently captured image is displayed (single image display).

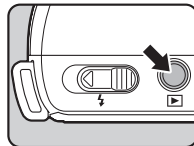

2 Review the captured image.

Available operations

◀	Displays the previous image.
▶	Displays the next image.
🗑	Deletes the image.
🔍 to the right	Magnifies the image (up to 16×). Use ▲▼◀▶ to change the display area. Press ● to return the display area to the center.
🔍 to the left	Thumbnail display (p.51)
📄	Saves the RAW image (only when the data is available).
ℹ	Changes the type of information displayed (p.11)

📄 Memo

- When  RAW is displayed on the monitor, the JPEG image that was just taken can also be saved in RAW format (Save RAW Data).

Selecting the Appropriate Capture Mode

Select the capture mode that suits the subject and shooting conditions.

The following capture modes are available on this camera.

Capture Mode	Application	Page
AUTO (Auto Picture modes)	The camera automatically selects the optimal capture mode from ☺ (Standard), 🗿 (Portrait), ▲ (Landscape), * (Macro), 🌃 (Night Scene Portrait), 🌅 (Sunset), 🌤 (Blue Sky) or 🌲 (Forest).	p.27
SCN (Scene modes)	You can choose the capture mode from various scene modes.	p.29
BC (Blur Control mode)	Enables you to create a picture that looks as if it was taken with a wide-open aperture and shallow depth of field, by shooting multiple images with different focus positions and merging them into a single image.	p.30
P/Tv/Av/M (Exposure modes)	Changes the shutter speed and aperture value.	p.31
🎥 (Movie mode)	Records a movie.	p.32

📌 Memo









- The functions that can be set vary depending on the capture mode. Refer to "Restrictions on Each Capture Mode" (p.69) for details.

Scene Modes

- 1 Set the mode dial to SCN.
The Scene mode selection screen appears.
- 2 Use ▲▼◀▶ to select a scene mode and press **OK**.



	Portrait	For capturing portraits. Reproduces a healthy and bright skin tone.
	Landscape	For capturing landscape views. Reproduces the vivid green of trees.
	Macro	For capturing tiny objects at close focus range like flowers, coins, jewelry, and more.
	Moving Object	For capturing images of fast moving subjects.
	Night Scene Portrait	For capturing images of people in low light conditions, such as dusk or at night.
	Sunset	For capturing sunrises or sunsets in beautiful, vivid color.
	Blue Sky	For capturing images of blue sky. Produces a more impressive deep blue.
	Forest	Enhances colors of trees and sunbeams through foliage and produces a vivid color image.
	Night Scene	Used for shooting at night.
	Night Scene HDR	Takes three consecutive images at three different exposure levels to create a single composite image with them.
	Night Snap	For taking snapshots in poorly lit place.
HDR	HDR	Captures 3 images to generate a single HDR image and provides a wider dynamic range.

 Quick Macro	For quick capture of tiny objects at close focus range.
 Food	For capturing images of food. Saturation will be rather high to make food look appetizing.
 Pet	For capturing moving pets.
 Kids	For capturing moving kids. Reproduces healthy and bright skin tone.
 Surf & Snow	For capturing images of dazzling backgrounds, such as snowy mountains.
 Backlight Silhouette	Produces a silhouette image of subject in backlight condition.
 Candlelight	For capturing scenes in candlelight.
 Stage Lighting	For capturing moving subjects in poorly lit place.
 Museum	For capturing images in places where a flash is prohibited.

Memo

- You can change the scene mode from the control panel or the  1 menu.

Blur Control Mode

- Set the mode dial to BC.



- Use  to adjust the level of blur.

Check the blur effect in the image by viewing it in playback mode.

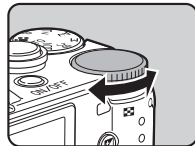

Caution

- The Blur Control mode is available only when an AF lens is used. (p.72)
- Do not move the camera while taking a picture.
- Some functions cannot be used in this mode. (p.69)
- The blur effect may not turn out as well as expected for the following situations and objects:
 - When the contrast is low overall
 - Fountains and other objects that change color or shape constantly
 - Moving objects
 - Small objects
 - Objects at the edge of the screen
 - Backlit scenes
 - When a special filter is used
 - Far-off objects

Exposure Modes

✓: Available #: Restricted ✕: Not available

Mode	Change Shutter Speed	Change Aperture value	Change Sensitivity	EV Compensation
P Program Automatic Exposure	# *1	# *1	✓	✓
Tv Shutter Priority Automatic Exposure	✓	✕	✓	✓
Av Aperture Priority Automatic Exposure	✕	✓	✓	✓
M Manual Exposure	✓	✓	✓ *2	✕

*1 You can set the value to be changed in [Green Button] of the  menu. (p.62)

*2 When the sensitivity is set to [ISO AUTO], the camera operates in **TAv** (Shutter & Aperture Priority Automatic Exposure) mode.

1 Set the mode dial to **P**, **Tv**, **Av** or **M**.

▶ appears next to the value that can be changed.



2 Use to adjust the value.

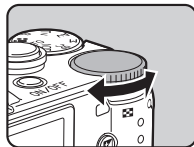

3 In **M** mode, press (1), and use (2) to change the aperture value.

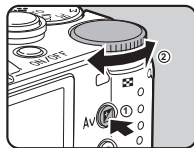



In **P/Tv/Av** mode, the exposure compensation value can be adjusted (from -3 to +3 EV in increments of 1/3 EV) by the same operation.





EV bar scale

Available operations

-  Starts/ends adjusting the compensation value.
-  Resets the adjustment value to the default setting.

Memo

- Exposure Bracketing shooting enables you to take pictures while automatically changing exposure. (p.41)
- A proper exposure may not be obtained with the selected shutter speed and aperture value when the sensitivity is set to the fixed value.
- In **M** mode, the difference from the proper exposure is displayed in the EV bar scale while the shutter speed or aperture value is adjusted.
- You can set the function of the  button for when the camera is in **M/TAv** mode. Set in [Green Button] of the 3 menu. (p.63)
- Sensitivity values higher than ISO 1600 are not available when the shutter speed is set to 2 seconds or slower in **Tv/M** mode.

Bulb Shooting

1 Set the mode dial to **M**.

2 Turn to the left.

Bulb appears after the slowest shutter speed.



3 Press the shutter release button.

The shutter remains open as long as the shutter release button is kept pressed (up to 30 seconds).



4 Take your finger off the shutter release button.

Exposure ends.

Caution





- Bulb shooting is available only when using a lens that has a lens shutter. (p.72)
- Some functions cannot be used in this mode. (p.69)

Checking the Depth of Field (Preview)

When [Preview] is assigned to  in [Green Button] of the 3 menu, you can check the depth of field before taking pictures. (p.62)

Movie Mode

1 Set the mode dial to .

Use  and  to adjust the exposure compensation value when [Exposure Setting] of the 1 menu is set to .

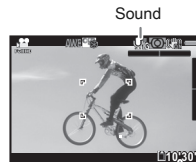

Recordable Time

2 Press the shutter release button halfway.

3 Press the shutter release button fully.

Movie recording starts.

 blinks at the top left of the screen.

When [Focus Method] is set to **AF**, press  to perform autofocus.

4 Press the shutter release button fully.

Movie recording stops.

⚠ Caution

- When recording a movie with sound, the camera operation sounds are also recorded.
- When recording a movie using any image processing function, such as Digital Filter, some frames may be omitted from the recorded movie file.
- If the internal temperature of the camera becomes high during recording, the recording may be terminated.

📄 Memo

- You can change the movie settings from the control panel or the 1 menu. (p.17)
- You can record a movie continuously up to 4 GB or 25 minutes. When the memory card is full, recording stops and the movie is saved.
- You can also use an optional remote control unit to record a movie. Select in the Drive Mode screen. (p.40)

Playing Back Movies



Available operations

▲	Plays back/pauses a movie.
▶	Forwards a frame (when paused).
Press and hold ▶	Fast-forwards playback.
◀	Reverses a frame (when paused).
Press and hold ◀	Fast-reverses playback.

▼	Stops playback.
	Adjusts the volume (6 levels).
	Saves the displayed frame as a JPEG file (when paused).

📄 Memo

- In [Movie Edit] of the playback mode palette, movies can be divided or selected frames can be deleted. (p.59)

Setting the Exposure

Sensitivity



- 1 Press ▲ in standby mode.
- 2 Use ▲ ▼ to select an item.

ISO AUTO	Automatic adjustment (default setting) The upper limit can be changed.
ISO	Sets a fixed value between ISO 100 to ISO 12800.



- 3 Use to change the value.

- 4 Press .

The camera returns to standby mode.

Memo

- Sets the adjustment steps for ISO sensitivity in [2. Sensitivity Steps] of the **C1** menu (default setting: 1 EV Step).
- Captured images may show more noise if a higher sensitivity is set. You can reduce image noise by using [High-ISO NR] of the **M2** menu.

Auto	Applies Noise Reduction at optimally calculated levels throughout ISO range. (Default setting)
Low/High	Applies Noise Reduction at constant chosen level throughout ISO range.

AE Metering



Choose the part of the sensor to use for measuring brightness and determining exposure.

Set in the control panel or [AE Metering] of the **M1** menu.

Multi-segment	The sensor meters the brightness in multiple different zones. (Default setting) In backlit locations, this mode automatically adjusts exposure. In [4. Link AE and AF Point] of the C1 menu, you can link the exposure and AF point in the focusing area.
Center-weighted	Metering is weighted at the center of the sensor. The sensitivity increases at the center and no automatic adjustment is performed even during backlit scenes.
Spot	The brightness is measured only within a limited area at the center of the sensor. Useful when the subject is small.

Using the Built-in Flash



- 1 Press **◀** in standby mode.
- 2 Use **◀▶** to select an item.



Auto Flash Discharge	Automatically measures the ambient light and determines whether to use the flash.
Auto Flash +Red-eye Reduction	Discharges a pre-flash for red-eye reduction before an automatic flash.
Flash On	Discharges a flash for each picture.
Flash On +Red-eye Reduction	Discharges a pre-flash for red-eye reduction before the main flash.
Slow-speed Sync	Sets to a slow shutter speed. Use this when shooting a portrait with the sunset in the background.
Slow-speed Sync+Red-eye	Discharges a pre-flash for red-eye reduction before the main flash is discharged with Slow-speed Sync.
Trailing Curtain Sync	Discharges a flash immediately before closing the shutter. Sets to a slow shutter speed. Captures moving objects as if they are leaving a light trail behind them.
Flash Off	The flash is deactivated.

- 3** Press **▼**, and use  to compensate the flash output. Press **○** to reset the value.



- 4** Press **OK**.
The camera returns to standby mode.

- 5** Slide the flash pop-up switch.

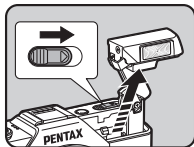

Caution

- Be sure to retract the built-in flash if not planning to use it. Be careful not to get your fingers pinched when retracting the flash.
- The built-in flash discharges even when retracted, which may cause vignetting to occur depending on the lens being used. If you do not want to let the built-in flash discharge while it is retracted, set [11. Flash When Retracted] in the **C2** menu.
- You cannot take pictures while the flash is being charged. If you want to take pictures while charging the flash, set [12. Release While Charging] in the **C2** menu.
- Depending on the lens being used, the use of the built-in flash may be limited. (p.72)

Memo

- The flash modes that can be selected vary depending on the capture mode.

Capture Mode	Selectable Flash Mode
AUTO, SCN *1	A,
BC	A, 1A, 1, 2, 3
P, Av	A, 1A, 1, 2, 3, 4, 5, 6, 7, 8, 9, 10, 11, 12, 13, 14, 15, 16, 17, 18, 19, 20, 21, 22, 23, 24, 25, 26, 27, 28, 29, 30, 31, 32, 33, 34, 35, 36, 37, 38, 39, 40, 41, 42, 43, 44, 45, 46, 47, 48, 49, 50, 51, 52, 53, 54, 55, 56, 57, 58, 59, 60, 61, 62, 63, 64, 65, 66, 67, 68, 69, 70, 71, 72, 73, 74, 75, 76, 77, 78, 79, 80, 81, 82, 83, 84, 85, 86, 87, 88, 89, 90, 91, 92, 93, 94, 95, 96, 97, 98, 99, 100, 101, 102, 103, 104, 105, 106, 107, 108, 109, 110, 111, 112, 113, 114, 115, 116, 117, 118, 119, 120, 121, 122, 123, 124, 125, 126, 127, 128, 129, 130, 131, 132, 133, 134, 135, 136, 137, 138, 139, 140, 141, 142, 143, 144, 145, 146, 147, 148, 149, 150, 151, 152, 153, 154, 155, 156, 157, 158, 159, 160, 161, 162, 163, 164, 165, 166, 167, 168, 169, 170, 171, 172, 173, 174, 175, 176, 177, 178, 179, 180, 181, 182, 183, 184, 185, 186, 187, 188, 189, 190, 191, 192, 193, 194, 195, 196, 197, 198, 199, 200, 201, 202, 203, 204, 205, 206, 207, 208, 209, 210, 211, 212, 213, 214, 215, 216, 217, 218, 219, 220, 221, 222, 223, 224, 225, 226, 227, 228, 229, 230, 231, 232, 233, 234, 235, 236, 237, 238, 239, 240, 241, 242, 243, 244, 245, 246, 247, 248, 249, 250, 251, 252, 253, 254, 255, 256, 257, 258, 259, 260, 261, 262, 263, 264, 265, 266, 267, 268, 269, 270, 271, 272, 273, 274, 275, 276, 277, 278, 279, 280, 281, 282, 283, 284, 285, 286, 287, 288, 289, 290, 291, 292, 293, 294, 295, 296, 297, 298, 299, 300, 301, 302, 303, 304, 305, 306, 307, 308, 309, 310, 311, 312, 313, 314, 315, 316, 317, 318, 319, 320, 321, 322, 323, 324, 325, 326, 327, 328, 329, 330, 331, 332, 333, 334, 335, 336, 337, 338, 339, 340, 341, 342, 343, 344, 345, 346, 347, 348, 349, 350, 351, 352, 353, 354, 355, 356, 357, 358, 359, 360, 361, 362, 363, 364, 365, 366, 367, 368, 369, 370, 371, 372, 373, 374, 375, 376, 377, 378, 379, 380, 381, 382, 383, 384, 385, 386, 387, 388, 389, 390, 391, 392, 393, 394, 395, 396, 397, 398, 399, 400, 401, 402, 403, 404, 405, 406, 407, 408, 409, 410, 411, 412, 413, 414, 415, 416, 417, 418, 419, 420, 421, 422, 423, 424, 425, 426, 427, 428, 429, 430, 431, 432, 433, 434, 435, 436, 437, 438, 439, 440, 441, 442, 443, 444, 445, 446, 447, 448, 449, 450, 451, 452, 453, 454, 455, 456, 457, 458, 459, 460, 461, 462, 463, 464, 465, 466, 467, 468, 469, 470, 471, 472, 473, 474, 475, 476, 477, 478, 479, 480, 481, 482, 483, 484, 485, 486, 487, 488, 489, 490, 491, 492, 493, 494, 495, 496, 497, 498, 499, 500, 501, 502, 503, 504, 505, 506, 507, 508, 509, 510, 511, 512, 513, 514, 515, 516, 517, 518, 519, 520, 521, 522, 523, 524, 525, 526, 527, 528, 529, 530, 531, 532, 533, 534, 535, 536, 537, 538, 539, 540, 541, 542, 543, 544, 545, 546, 547, 548, 549, 550, 551, 552, 553, 554, 555, 556, 557, 558, 559, 560, 561, 562, 563, 564, 565, 566, 567, 568, 569, 570, 571, 572, 573, 574, 575, 576, 577, 578, 579, 580, 581, 582, 583, 584, 585, 586, 587, 588, 589, 590, 591, 592, 593, 594, 595, 596, 597, 598, 599, 600, 601, 602, 603, 604, 605, 606, 607, 608, 609, 610, 611, 612, 613, 614, 615, 616, 617, 618, 619, 620, 621, 622, 623, 624, 625, 626, 627, 628, 629, 630, 631, 632, 633, 634, 635, 636, 637, 638, 639, 640, 641, 642, 643, 644, 645, 646, 647, 648, 649, 650, 651, 652, 653, 654, 655, 656, 657, 658, 659, 660, 661, 662, 663, 664, 665, 666, 667, 668, 669, 670, 671, 672, 673, 674, 675, 676, 677, 678, 679, 680, 681, 682, 683, 684, 685, 686, 687, 688, 689, 690, 691, 692, 693, 694, 695, 696, 697, 698, 699, 700, 701, 702, 703, 704, 705, 706, 707, 708, 709, 710, 711, 712, 713, 714, 715, 716, 717, 718, 719, 720, 721, 722, 723, 724, 725, 726, 727, 728, 729, 730, 731, 732, 733, 734, 735, 736, 737, 738, 739, 740, 741, 742, 743, 744, 745, 746, 747, 748, 749, 750, 751, 752, 753, 754, 755, 756, 757, 758, 759, 760, 761, 762, 763, 764, 765, 766, 767, 768, 769, 770, 771, 772, 773, 774, 775, 776,

Focusing

Focus Method



Set [Focus Method] to **AF** or **MF** in the control panel or [AF/MF Settings] of the 1 menu.

Memo

- In **AF** mode, when the subject is in a dark location, the AF assist light is used when the shutter release button is pressed halfway. To change the setting, set [AF Assist Light] in [AF/MF Settings] of the 1 menu.
- You can use to focus on the subject. In that case, the autofocus by pressing the shutter release button halfway is disabled. (p.62)
- In **AF** mode, focus ring operations can be disabled to prevent accidentally moving the lens focus ring and causing the picture to be out of focus. Set in [10. Focus Ring in AF Mode] of the **C2** menu.

Setting the Autofocus Method



You can choose from the following autofocus methods.



Face Detection	Detects and tracks faces of people. The main face detection frame for AF and AE is displayed in yellow.
Tracking	Tracks the subject in focus. The shutter can be released by pressing the shutter release button fully even if the subject is not in focus.
Multiple AF Points	Sets the focusing area to the desired area. (Default setting) The sensor is divided into 49 areas (7 horizontal by 7 vertical), and you can select a wider or narrower focusing area by using 25, 9, or just 1 of those 49 areas available.
Select	Sets the focusing area by the number of pixels.
Spot	Sets the focusing area to a limited area at the center.

Memo

- Fixed to or depending on the capture mode. (p.69)
- In **AF** mode, you can take pictures only when the subject is in focus. To take pictures when the subject is not in focus, set [8. AF Release Options] to [Release-priority] in the **C2** menu.
- Selecting , , or enables to lock the focus and recompose the picture while the shutter release button is pressed halfway.





Selecting the Desired Focusing Area

You can set the position and range of the autofocus area (AF area).

- 1 Set [Autofocus Method] to  or .
- 2 Press **MENU**.
The camera is in standby mode.
- 3 Press **OK**.
- 4 Select the AF area.



Available operations

-
- | | |
|---|--|
|  | Changes the position of the AF area. |
|  | When  is selected: increases/reduces the size of the AF area. |
-
- | | |
|---|------------------------------------|
|  | Returns the AF area to the center. |
|---|------------------------------------|
-

- 5 Press **OK**.
The AF area is set.

Adjusting the Focus Manually (Manual Focus)

- 1 Set [Focus Method] to MF.
- 2 Press **MENU**.
The camera is in standby mode.
- 3 While viewing the monitor, turn the focus ring.
The shutter is released by pressing the shutter release button fully even if the subject is not in focus.

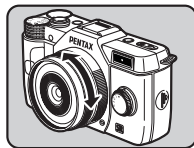

Focusing with the Image Magnified



The image in the center of the monitor is automatically magnified when the focus ring is turned.

- 1 Select [MF Autozoom] in [AF/MF Settings] of  1 menu.
- 2 Select the magnification level and press **OK**.
- 3 Press **MENU** twice.
The camera is in standby mode.

4 Turn the focus ring.

The image on the monitor is magnified.



Available operations



Magnifies the image (x2, x4, or x6).



Changes the area to display.
Press **○** to change the display area to the center.



Returns to the original size.

Memo





- When [Focus Peaking] is set to [On] in the control panel or [AF/MF Settings] of the 1 menu, the outline of the subject in focus is emphasized and makes it easier to check the focus. This function works in both **AF** and **MF** modes.

Setting the Drive Mode



You can choose from the following drive modes.

<input type="checkbox"/>	Single Frame Shooting	Normal capture mode
	Continuous Shooting (Hi)	Pictures are taken continuously while the shutter release button is kept pressed. You can capture up to approx. 5 frames at once. Not available when [File Format] is set to [RAW] or [RAW+].
	Continuous Shooting (Lo)	You can capture up to approx. 100 frames at once.
	Self-timer (12 sec.)	The shutter is released about 12 seconds after the shutter release button is pressed.
	Self-timer (2 sec.)	The shutter is released about 2 seconds after the shutter release button is pressed.
	Remote Control	The shutter is released immediately after the shutter release button on the remote control unit is pressed.
	Remote Control (3 sec. delay)	The shutter is released about 3 seconds after the shutter release button on the remote control unit is pressed.
	Remote Continuous Shooting	Continuous shooting starts when the shutter release button on the remote control unit is pressed. Continuous shooting ends when the shutter release button is pressed again.
	Exposure Bracketing	Takes three consecutive images at three different exposure levels. Three images are saved with each release in the order of standard exposure, underexposure and overexposure.
	Exposure Bracket+ Remote Ctrl	Enables Exposure Bracketing shooting with remote control.
	Multi-exposure	Creates a picture by taking multiple exposures and merging them into a single image.

 Self-timer+ Multi-exposure	Enables Multi-exposure shooting with the self-timer.
 Remote Control+ Multi-exposure	Enables Multi-exposure shooting with remote control.
 Interval Shooting	Takes pictures at a set interval from a set time.
 Interval Movie Record	Takes still pictures at a set interval from a set time and saves it as a single movie file. Available only in  mode.

Caution

- The Drive Mode settings that can be set vary depending on the capture mode. (p.69)

Memo

- The Drive Mode setting is saved even after the power is turned off. If [Drive Mode] is set to [Off] in [Memory] of the  3 menu, the setting returns to Single Frame Shooting when the power is turned off. (p.65)
- The Shake Reduction function is automatically turned off when Self-timer or Remote Control is selected. If you do not want to turn it off, set [16. Auto SR Off] in the **C3** menu.

Continuous Shooting

- 1 Press  in standby mode.**
The Drive Mode screen appears.

- 2 Use  to select  and press .**



- 3 Use  to select  or  and press .**
The camera returns to standby mode.

Caution

- The number of recordable frames varies according to the set aspect ratio.
- You cannot take pictures while the flash is being charged. If you want to take pictures while the flash is charging, set [12. Release While Charging] in the **C2** menu.

Memo

- The focus position is locked in the first frame.

Self-timer Shooting

- 1 Press **▶** in standby mode.
The Drive Mode screen appears.

- 2 Use **◀▶** to select  and press **▼**.



- 3 Use **◀▶** to select  or  and press **OK**.
The camera returns to standby mode.



- 4 Press the shutter release button halfway → fully.
The self-timer lamp blinks.
The shutter will be released about 12 seconds or 2 seconds.

Remote Control Shooting

- 1 Press **▶** in standby mode.
The Drive Mode screen appears.

- 2 Use **◀▶** to select  and press **▼**.



- 3 Use **◀▶** to select , , or  and press **OK**.
The camera returns to standby mode.
The self-timer lamp blinks.



- 4 Press the shutter release button halfway.

- 5 Point the remote control unit towards the remote control receiver on the front or back of the camera, and press the shutter release button on the remote control unit.

Memo

- The maximum operating distance of the remote control unit is approx. 4 m from the front of the camera and approx. 5 cm from the back of the camera.
- To use the remote control unit to adjust the focus, set in [9. AF with Remote Control] of the **C2** menu.
- When using the Remote Control Waterproof O-RC1, the autofocus system can be operated with the  button. The **Fn** button cannot be used.



Exposure Bracketing

- 1 Press \blacktriangleright in standby mode.**
The Drive Mode screen appears.
- 2 Use $\blacktriangleleft \blacktriangleright$ to select  and press \blacktriangledown .**
- 3 Use $\blacktriangleleft \blacktriangleright$ to select  or  and press \blacktriangledown .**
- 4 Set the bracket value.**

The bracket value can be set in increments of 1/3 EV.



Available operations





-
- | | |
|---|---|
|  | Changes the bracket value. |
|  | Adjusts the exposure compensation value. |
|  | Resets the adjustment value to the default setting. |
-

- 5 Press OK .**
The camera returns to standby mode.

Memo

- You can set the bracketing order in [5. Bracketing Order] of the **C1** menu.

Multi-exposure

- 1 Press \blacktriangleright in standby mode.**
The Drive Mode screen appears.
- 2 Use $\blacktriangleleft \blacktriangleright$ to select  and press \blacktriangledown .**
- 3 Use $\blacktriangleleft \blacktriangleright$ to select ,  or , and press \blacktriangledown .**
- 4 Use $\blacktriangleleft \blacktriangleright$ to select the number of shots.**



Select from 2 to 9 shots.

Set [Auto EV Adjustment] to to adjust exposure automatically according to the number of shots.



- 5 Press OK .**
The camera returns to standby mode.
- 6 Shoot.**
Instant Review is displayed.

Available operations

-
- | | |
|---|---|
|  | Discards pictures taken up to that point and takes pictures again from the first picture. |
|  | Saves pictures taken up to that point and returns to standby mode. |
-

After the set number of pictures are taken, the camera returns to normal capture mode.

Interval Shooting

- 1 Press **▶** in standby mode.
The Drive Mode screen appears.
- 2 Use **◀▶** to select  and press **▼**.
- 3 Use **▲▼◀▶** to set the shooting conditions.

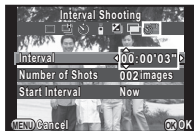

Interval	For taking two or more pictures, set the wait time until the next picture is taken from 3 seconds to 24 hours.
Number of Shots	Set the number of shots to be taken from 2 to 999.
Start Interval	Select whether to take the first picture now or at a set time.
Start Time	When [Start Interval] is set to [Set Time], set the time at which to start shooting.



- 4 Press **OK** to finish the setting.
The camera returns to standby mode.
- 5 **Shoot.**
When [Start Interval] is set to [Now], the first picture is taken. When set to [Set Time], shooting starts at the set time. To cancel shooting, press **MENU**.
After the set number of pictures are taken, the camera returns to normal capture mode.

Memo

- The focus position is locked in the first frame.

Interval Movie Record

In  mode, you can use [Interval Movie Record] to take still pictures at a set interval from a set time and save them as a single movie file (Motion JPEG, file extension: .AVI).

- 1 Set the mode dial to  and press **▶**.
The Drive Mode screen appears.
- 2 Use **◀▶** to select  and press **▼**.
- 3 Use **▲▼◀▶** to set the shooting conditions.



Interval	Select from 3 sec., 5 sec., 10 sec., 30 sec., 1min., 5 min., 10 min., 30 min., or 1 hour.
Recording Time	Set the time at which to start and stop recording from 12 seconds to 99 hours. The time that can be set varies depending on [Interval] setting.
Start Interval	Select whether to take the first picture now or at a set time.
Start Time	When [Start Interval] is set to [Set Time], set the time at which to start shooting.

- 4 Press **OK** to finish the setting.
The camera returns to standby mode.

5 Shoot.

When [Start Interval] is set to [Now], the first picture is taken.
Instant Review is displayed, and then the monitor turns off.
After the set number of pictures are taken, the camera returns to normal movie recording mode.

Setting a File Format

Still Pictures



Set the file format for still pictures in the control panel or [Image Capture Settings] of the 1 menu.

Aspect Ratio	(default setting),
File Format	JPEG (default setting), RAW, RAW+
JPEG Recorded Pixels	(default setting), ,
JPEG Quality	★★★ (default setting), ★★, ★

⚠ Caution

- When [File Format] is set to [RAW] or [RAW+], some functions are not available. [RAW] and [RAW+] cannot be selected for some capture modes. (p.69)

📝 Memo

- When [File Format] is set to [RAW+], a JPEG image and RAW image with the same file number are saved at the same time.
- By assigning [One Push File Format] to , you can take pictures with a different file format setting only when the button is pressed. (p.62)

Movies



Set the file format for movies in the control panel or [Movie Capture Settings] of the 1 menu.

Recorded Pixels	(default setting), ,
Framerate	30 fps (default setting), 25 fps, 24 fps

Adjusting the Color and Brightness of Images

White Balance



1 Press in standby mode.

The White Balance setting screen appears.

2 Use to select an item.

When is selected, press and use to select , , or .



White Balance	Color Temperature
AWB Auto	Approx. 4,000 to 8,000K
Daylight	Approx. 5,200K
Shade	Approx. 8,000K
Cloudy	Approx. 6,000K
Fluorescent - Daylight Color	Approx. 6,500K
Fluorescent - Daylight White	Approx. 5,000K
Fluorescent - Cool White	Approx. 4,200K
Fluorescent - Warm White	Approx. 3,000K
Tungsten	Approx. 2,850K
Flash	Approx. 5,400K
CTE Color Temperature Enhancement	—
Manual 1 to 3	—

Proceed to Step 5 if you do not need to change the parameters.

3 Press .

The fine-tuning screen appears.

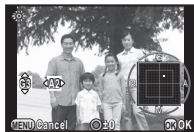

Available operations

	Adjust: Green-Magenta
	Adjust: Blue-Amber
	Resets the adjustment value to the default setting.

4 Press .

The screen of Step 2 reappears.

5 Press .

The camera returns to standby mode.

Memo

- You can set the white balance for when the flash discharges in [6. WB When Using Flash] of the **C1** menu.

Adjusting the White Balance Manually

Measure the white balance of a location.

1 Select in Step 2 on p.43 and press .

2 Use to select 1 to 3.



3 Under the light you wish to measure the white balance of, select a white area as the subject, and press the shutter release button fully.

Adjust the white balance as necessary.

[The operation could not be completed correctly] appears when measuring is unsuccessful. Press to remeasure the white balance.

4 Press .

The camera returns to standby mode.

Memo

- You can copy the white balance settings of a captured image and save it as 1 to 3 in [Save as Manual WB] of the playback mode palette. (p.50)

Adjusting Brightness

Highlight Correction/ Shadow Correction



Expands the dynamic range and enables a wider range of tones by the CMOS sensor and reduces the occurrence of overexposed/underexposed areas.

Set in the control panel or [D-Range Settings] of the 2 menu.



Caution

- When the sensitivity is set to ISO 100, [Highlight Correction] cannot be set to [On].

HDR Capture



Takes three consecutive images at three different exposure levels to create a single composite image with them.

Set in the control panel or [HDR Capture] of the 1 menu.

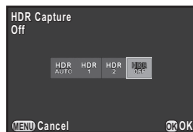

Caution

- This function cannot be used in some capture modes or in combination with some other functions. (p.69)

- During HDR Capture, multiple images are combined together to create a single image, so it will take time to save the composite image.

Memo

- Specific HDR settings are used and HDR Capture cannot be set when or **HDR** of **SCN** mode is selected.

Controlling the Image Finishing Touch

When you want to take images with a slightly different style, you can set the desired picture style before you start shooting. The following functions are available. Try out the various settings, and find the shooting method that best suits your style.

Custom Image	Sets the image finishing touch such as [Bright] and [Portrait].
Digital Filter	Takes images using various filters.
Smart Effect	Takes images using various effects.

Custom Image



- 1 Select [Custom Image] from or 1 menu, and press **OK**.

The Custom Image setting screen appears.

- 2 Use **▲▼◀▶** to select an image finishing touch.



Bright
Natural
Portrait
Landscape
Vibrant
Radiant

Muted
Bleach Bypass
Reversal Film
Monochrome
Cross Processing

Proceed to Step 6 if you do not need to change the parameters.

- 3 Press **OK**.

The parameter setting screen appears.

- 4 Use **▲▼** to select a parameter.



Available operations

- Adjusts the values.
- Switches between [Sharpness] and [Fine Sharpness]. (Not available in mode).
- Resets the adjustment value to the default setting.

- 5 Press **OK**.

The screen of Step 2 reappears.

- 6 Press **OK**.

- 7 Press **MENU**.

The camera returns to standby mode.

Saving the Cross Processing Settings of a Captured Image

The outcome of Cross Processing for Custom Image and Smart Effect varies each time a picture is taken. If you take a cross processed image that you like, you can save the Cross Processing settings used in that image, so you can load and use the same settings again.

1 Press **▼** in single image display of playback mode.
The playback mode palette appears.

2 Use **▲▼◀▶** to select  and press **OK**.

The camera will search for cross processed images starting from the most recent image taken.

[No cross processed image] appears if there are no cross processed images.

3 Use  to select a cross processed image.



4 Use **▲▼** to select a number and press **OK**.

The settings of the selected image are saved to [Favorite 1 - 3].

Memo

- Saved cross processing settings can be loaded by selecting [Cross Processing] in [Custom Image], and selecting [Favorite 1 - 3] for the parameter.

Digital Filter



1 Select [Digital Filter] from  or  menu and press **OK**.

The Digital Filter setting screen appears.

2 Use **▲▼◀▶** to select a filter.

Select [No Filter] to not shoot with a digital filter.



Toy Camera
High Contrast
Shading
Tone Expansion
Invert Color
Extract Color

Unicolor Bold
Water Color
Posterization
Slim
Fish-eye

Proceed to Step 6 if you do not need to change the parameters.

3 Press **☑**.

The parameter setting screen appears.

4 Use **▲▼** to select a parameter, and use **◀▶** to adjust the value.



5 Press **OK**.
The screen of Step 2 reappears.

6 Press **OK**.

7 Press **MENU**.
The camera returns to standby mode.

⚠ Caution

- This function cannot be used in some capture modes or in combination with some other functions. (p.70)
- Depending on the filter used, it may take longer to save images.

📄 Memo

- Images can be processed with digital filters in playback mode. (p.57)

Saving Frequently Used Functions to the Quick Dial



One of the following functions can be saved in the quick dial located on the front side of the camera. You can save frequently used functions to the quick dial to easily change the settings.

Smart Effect (default setting)	Focus Method
Aspect Ratio	Focus Peaking
	ND Filter

1 Select **[Quick Dial]** in **Q3** menu and press **▶**.
The [Quick Dial] screen appears.

2 Press **▶**, and use **▲▼** to select the function to save.

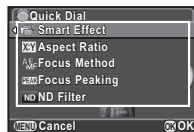

3 Press **OK**, and then press **▼**.

4 Use **▲▼** to select the position 1-4 of the quick dial.



5 Use **◀▶** to select the desired setting.
Select a Smart Effect setting from those listed below.



Brilliant Color	Tone Expansion
Unicolor Bold	Bold Monochrome
Vintage Color	Water Color
Cross Processing	Vibrant Color Enhance
Warm Fade	USER 1 to 3

6 Press **OK**.
The screen of Step 4 reappears.
Repeat Steps 4 to 6 to save the settings to the other positions.

7 Press **MENU** twice.

The camera returns to standby mode.

Memo

- The shooting settings of your favorite images can be saved in [USER1 - 3] of [Smart Effect]. You can quickly shoot images with your favorite settings by using the quick dial. (p.63)

Loading Settings for Taking Pictures

You can take pictures with the settings saved in the quick dial. When you use the quick dial to take pictures, priority is given to the settings saved in the quick dial.

- 1 In standby mode, turn the quick dial to select the position 1 to 4.

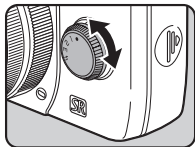

- 2 Shoot.

- 3 After taking pictures, return the quick dial to the position 0.

The camera returns to the original settings.

Caution

- You cannot use the menus to change the settings when taking pictures with the quick dial. To change the settings of the quick dial, save other settings again.

Shooting with Smart Effect

- 1 Save [Smart Effect] for [Quick Dial].

- 2 In standby mode, turn the quick dial to select the position 1 to 4.

- 3 Press **▼** to change the parameters.
The parameter setting screen appears.

- 4 Use **◀▶** to change the parameters.





- 5 Press **OK**.
The camera returns to standby mode.

Caution









- This function cannot be used in combination with some other functions. (p.70, 71)







Playback Mode Palette Items

Playback functions can be specified in the playback mode palette as well as the  1 menu (p.17).

Press  in single image display of the playback mode to display the playback mode palette.



Item	Function	Page
 Image Rotation *1	Changes the rotation information of images.	p.53
 Digital Filter *1	Processes images with digital filters.	p.57
 Red-eye Edit *1 *2	Corrects images of a subject captured with red eyes.	p.57
 Resize *1 *2	Changes the number of recorded pixels or size of the image.	p.56
 Cropping *1 *2	Crops out only the desired area of an image.	p.56
 Index	Joins a number of images together and creates an index image with them.	p.58
 Protect	Protects images from being accidentally erased.	p.65
 DPOF *1 *2	Embeds the number of prints and date in images.	p.68
 Slideshow	Plays back images one after another.	p.53

Item	Function	Page
 Save as Manual WB *1	Saves the white balance settings of the captured image as Manual White Balance.	p.44
 Save Cross Processing	Saves the settings used for an image captured in Cross Processing mode of Custom Image or Smart Effect as your "Favorite" settings.	p.47
 Save Smart Effect *1	Saves the shooting settings of your favorite image to the quick dial.	p.63
 RAW Development *3	Converts RAW images to JPEG format.	p.60
 Movie Edit *4	Divides a movie or deletes unwanted segments.	p.59
 Eye-Fi Image Transfer	Transfers selected images wirelessly using an optional Eye-Fi card.	p.67

*1 Not available when a movie is displayed.

*2 Not available when a RAW image is displayed.

*3 Available only when a RAW image is saved.

*4 Available only when a movie is displayed.

Changing the Playback Method

Displaying Multiple Images

You can display 4, 9, 30 or 56 thumbnail images at the same time. (Default setting: 9 Thumbnail Display)

- 1 Turn  to the left in playback mode.

The multi-image display screen appears.



Available operations

 Moves the selection frame.

 Shows the display style selection screen.



 Deletes the selected images.

- 2 Press .

The selected image appears in single image display.

Deleting Selected Images

- 1 Press  in Step 1 of "Displaying Multiple Images".



- 2 Select the images to delete.



Available operations

 Moves the selection frame.

 Confirms/cancels the selection of the image to delete.

 Shows the selected image in single image display.
Use  to select a different image.

- 3 Press .
The delete confirmation screen appears.

- 4 Select [Select & Delete] and press .

Memo

- You can select up to 100 images at a time.
- Protected images cannot be selected.

Displaying Images by Folder

- 1 Turn  to the left in Step 1 of “Displaying Multiple Images”.

The folder display screen appears.



Available operations

   Moves the selection frame.

 Deletes the selected folder.

- 2 Press **OK**.

The images in the selected folder are displayed.

Deleting a Folder

- 1 Select a folder to delete in Step 1 of “Displaying Multiple Images by Folder”, and press .

The delete confirmation screen appears.

- 2 Select [Delete] and press **OK**.

The selected folder and all images in it are deleted. When there are protected images in the folder, select [Delete all] or [Leave all].

Displaying Images by Shooting Date

Images will be grouped and displayed by the shooting date.

- 1 Select **INFO** in Step 1 of “Displaying Multiple Images”.

The display style selection screen appears.

- 2 Select [Calendar Filmstrip Display].

Number of images shot on this date





Shooting date

Thumbnail

Available operations

  Selects a shooting date.

  Selects an image taken on the selected shooting date.

 to the right Shows the selected image in single image display.

 Deletes the selected image.

- 3 Press **OK**.

The selected image appears in single image display.

⚠ Caution





- Calendar Filmstrip Display is not available when there are more than 100,000 image files saved on the memory card.

Playing Back Images Continuously (Slideshow)

1 Select in the playback mode palette.

Slideshow starts.

Available operations

	Pauses/resumes playback.
	Displays the previous image.
	Displays the next image.
	Stops playback.

After all images are played back, the camera returns to the single image display.

Memo

- You can change the [Display Duration], [Screen Effect], [Repeat Playback] and [Auto Movie Playback] settings for slideshow in [Slideshow] of the 1 menu. Slideshow can be started from the Slideshow setting screen.

Displaying Rotated Images

When you take pictures with the camera held vertically, the image rotation information is saved when shooting. During playback, the image is automatically rotated based on the rotation information when [Auto Image Rotation] in the 1 menu is set to [On] (default setting).

The rotation information of an image can be changed by following the procedure below.

1 Display the image to edit in single image display.

2 Select in the playback mode palette.

The selected image is rotated in 90° increments and the four thumbnail images are displayed.

3 Use to select the desired rotation direction and press .

The image rotation information is saved.



Caution

- When [14. Save Rotation Info] is set to [Off] in the **C3** menu, the image rotation information is not saved when shooting.
- You cannot change the rotation information for the following images and situation.
 - Protected images
 - Images without a rotation information tag
 - When [Auto Image Rotation] is set to [Off] in the 1 menu
- Movie files cannot be rotated.

Connecting the Camera to an AV Device

You can connect the camera to a TV or other device with a video input terminal or HDMI input terminal and play back images. Have a cable according to the terminal of the device to which you connect.

Terminal of AV Device	Cable Used
Video terminal	AV cable I-AVC7 (optional)
HDMI terminal	HDMI cable with an HDMI terminal (Type D) (commercially available)

- 1 Turn the AV device and camera off.
- 2 Open the terminal cover of the camera, and connect the cable to either the PC/AV terminal or HDMI terminal.

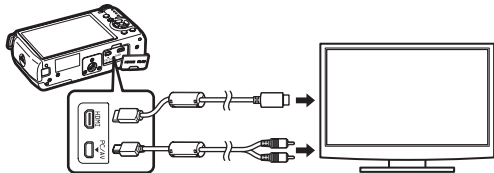

- 3 Connect the other end of the cable to the input terminal on the AV device.
- 4 Turn the AV device and camera on.
The camera turns on in video mode or HDMI mode, and the camera information is displayed on the screen of the connected AV device.

⚠ Caution

- When using the video output, images are output at normal resolution regardless of the resolution supported by the AV device. To output HD video, use the HDMI output or transfer to and play back on a computer.
- While the camera is connected to an AV device, nothing is displayed on the camera monitor. Also, you cannot adjust the volume on the camera. Adjust the volume on the AV device.
- You cannot output both composite and HDMI video signals at the same time.

📝 Memo

- Check the operating manual of the AV device and select a suitable input terminal for connecting the camera.
- If you intend to use the camera continuously for a long period, use of the AC adapter kit (optional) is recommended.
- When the hometown is set at the time of initial setting (p.25), the video output format is also set in accordance with that region. When you set [Time Setting] to [Destination] in [World Time] of the **↖1** menu, the video output setting changes to the video output format for that city. Depending on the country or region, images may fail to be played back with the set video output format. If this happens, change the setting in [Video Out] of [Interface Options] in the **↖2** menu. Refer to "List of World Time Cities" (p.82) for video output format for cities that can be selected as a hometown or destination.
- By default, the maximum resolution is automatically selected to suit the AV device and camera. If it fails to play back images properly, change the setting in [HDMI Out] of [Interface Options] in the **↖2** menu.

Connecting the Camera to a Computer

Connect the camera to a computer using the provided USB cable I-USB7.

- 1 Turn the computer on.
- 2 Turn the camera off.
- 3 Open the terminal cover of the camera, and connect the USB cable to the PC/AV terminal.

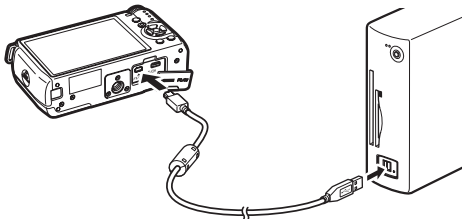

- 4 Connect the USB cable to the USB port of the computer.

- 5 Turn the camera on.

The camera is recognized as a removable disk.

If the "Q7" dialog appears when the camera is turned on, select [Open folder to view files using Windows Explorer] and click the OK button.

- 6 Save the captured images to the computer.

- 7 Disconnect the camera from the computer.

Caution

- The camera cannot be operated while it is connected to a computer. To operate the camera, terminate the USB connection on the computer, then turn off the camera and remove the USB cable.

Memo

- Refer to p.83 for system requirements to connect the camera to a computer or to use the software.

Editing and Processing Images

Changing the Image Size

⚠ Caution

- Only JPEG images captured with this camera can be resized or cropped.
- Images already resized or cropped to the minimum file size with this camera cannot be processed.



Changing the Number of Recorded Pixels (Resize)

Changes the number of recorded pixels, and saves the image as a new file.

1 Display the image to edit in single image display.

2 Select  in the playback mode palette.

The screen to select the recorded pixels appears.

3 Use   to select the number of recorded pixels and press **OK**.

You can select one of the image sizes starting from one size smaller than that of the original image.



4 Select **[Save as]** and press **OK**.

Cropping Out Part of the Image (Cropping)

Crops out only the desired area of the selected image and saves it as a new image.

1 Display the image to edit in single image display.







2 Select  in the playback mode palette.

The cropping frame to specify the size and position of the area to crop appears on the screen.

3 Specify the size and position of the area to crop by using the cropping frame.



Available operations

	Changes the size of the cropping frame.
   	Moves the cropping frame.
	Changes the aspect ratio.
	Rotates the cropping frame (only when possible).

4 Press **OK**.

5 Select **[Save as]** and press **OK**.

Removing the Red-eye Effect

You can correct images where the flash has caused the subject to appear with red eyes.

1 Display the image to edit in single image display.

2 Select  in the playback mode palette.

[The operation could not be completed correctly] appears when red eyes cannot be detected on the camera.

3 Select [Save as] and press **OK**.

Caution

- The Red-eye Edit function can be used only for the JPEG images captured with this camera.

Processes images with Digital Filters

1 Display the image to edit in single image display.

2 Select  in the playback mode palette.

The screen to select a filter appears.

3 Use **▲▼◀▶** to select a filter.

Use  to select a different image.



Base Parameter Adj
Toy Camera
High Contrast
Shading
Tone Expansion
Invert Color
Extract Color
Unicolor Bold
Water Color

Posterization
Slim
Fish-eye
Retro
Sketch
Miniature
Soft
Starburst

Proceed to Step 6 if you do not need to change the parameters.

4 Press **OK**.

The parameter setting screen appears.

5 Use **▲▼** to select a parameter, and use **◀▶** to adjust the value.

The parameters that can be set varies depending on the selected filter.



6 Press **OK**.

The save confirmation screen appears.

7 Select [Apply additional filter(s)] or [Save as] and press **OK**.

Select [Apply additional filter(s)] when you want to apply additional filters to the same image. The screen of Step 3 reappears.

Caution

- Only JPEG and RAW images captured with this camera can be edited with the digital filters.

Memo

- Up to 20 filters, including a digital filter used during shooting (p.47), can be applied to the same image.

Recreating Filter Effects

Retrieves the filter effects of a selected image and applies the same filter effects to other images.

1 Display a filter-processed image in single image display.

2 Select **0** in the playback mode palette.

3 Select [Recreating filter effects] and press **OK**.

The filter effects used for the selected image appear.



4 To check the parameter details, press **INFO**.

Press **INFO** again to return to the previous screen.



5 Press **OK**.

The image selection screen appears.

6 Use **0** to select an image for applying the same filter effects, and press **OK**.

You can only select an image that has not been processed with a filter.



7 Select [Save as] and press **OK**.

Memo

- If [Searching for the original image] is selected in Step 3, the original image prior to digital filter application can be retrieved.

Creating a Composite Image (Index)

Joins a number of images together and creates a new image with them.

1 Select **0** in the playback mode palette.

The Index setting screen appears.

2 Select [Layout].

Select from **0** (Thumbnail), **1** (Square), **2** (Random1), **3** (Random2), **4** (Random3) or **5** (Bubble).

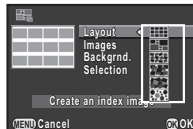





3 Select the number of images from 12, 24 or 36 in [Images].

When the number of saved images is smaller than the number selected, empty spaces will appear when [Layout] is set to **0** and some images may be duplicated for other layouts.

4 Select the background color from white, black, wood grain, cork, or water in [Backgrnd.].

5 Select a type of image selection in [Selection].

 Auto	Picks images automatically from all of the images saved.
 Select image(s)	Lets you select images that you want to include in the index image. If  is selected, [Select image(s)] appears and leads you to the image selection screen.
 Select a folder	Picks images automatically from the folder selected. If  is selected, [Select a folder] appears and leads you to the folder selection screen.

6 Select [Create an index image] and press **OK**.

The index image appears.

7 Select [Save] or [Reshuffle] and press **OK**.

When [Reshuffle] is selected, you can reselect the images to be included in the index and display a new index image.

Memo

- The file name format for index image is "INDXxxxx.JPG".

Editing Movies

1 Display the movie to edit in single image display.

2 Select  in the playback mode palette.





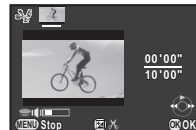

The movie editing screen appears.

3 Select the point where you want to divide the movie.

The frame at the dividing point is displayed at the top of the screen. Up to four points can be selected to divide the original movie into five segments.



Available operations

	Plays back/pauses a movie.
	Forwards a frame (when paused).
Press and hold 	Fast-forwards playback.
	Reverses a frame (when paused).
Press and hold 	Fast-reverses playback.
	Confirms/cancels a dividing point.
	Adjusts the volume.

Proceed to Step 7 if you do not delete any segment.

4 Press .

The screen to select segments to delete is displayed.

5 Use ◀▶ to move the selection frame and press OK.

The segment(s) to delete are specified.

(Multiple segments can be deleted at once.)

Press OK again to cancel the selection.

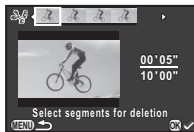

6 Press MENU.

The screen of Step 3 reappears.

7 Press OK.

The save confirmation screen appears.

8 Select [Save as] and press OK.

Memo

- Select dividing points in chronological order from the beginning of the movie. When canceling the selected dividing points, cancel each of them in reverse order (from the end of the movie to the beginning). In an order other than specified, you can neither select frames as a dividing point nor cancel the selections of the dividing points.

RAW Development

You can convert RAW images into JPEG images, and save them as a new file.

1 Select RAW in the playback mode palette.

The screen for selecting a RAW image processing option appears.

2 Select the desired option and press OK.

Develop a single image	Develops an image.
Develop multiple images	Develops up to 500 images with the same settings.
Develop images in folder	Develops up to 500 images in the selected folder with the same settings.

When [Develop a single image] is selected, proceed to Step 5. The image/folder selection screen appears.

3 Press OK to select images or folders.

When [Develop multiple images] is selected, up to 500 images can be selected. Press [OK] to finish the setting.

The screen for selecting the parameter setting method appears.



4 Select the parameter setting method and press **OK**.



Develop images as shot	Allows you to change Image Capture Settings only.
Develop images with modified settings	Allows you to change Image Capture Settings, White Balance, Custom Image, Digital Filter, Sensitivity, High-ISO NR, Shadow Correction, and Distortion Correction.

5 Use **▲▼** to select the parameter to change, and use **◀▶** to change the value.

For Image Capture Settings, press **▶** and use **▲▼** to select an item.

For White Balance, Custom Image and Digital Filter, press **▶** to display the setting screen.



6 Press **OK**.

The save confirmation screen appears.

7 Select **[Save as]** and press **OK**.

When **[Develop a single image]** is selected, select **[Continue]** or **[Exit]** and press **OK**.

⚠ Caution

- Only RAW images captured with this camera can be developed.



📝 Memo

- When **[Develop multiple images]** or **[Develop images in folder]** is selected in Step 2, a "xxxR_JPG" folder with a new number is created, and the JPEG images are stored in the new folder.
- With the provided software "SILKYPIX Developer Studio 3.0 LE", you can develop RAW files on a computer.

Camera Settings

Setting the / Functions





The functions assigned to  and  can be changed with [Green Button] of the 3 menu.

Setting the Operation

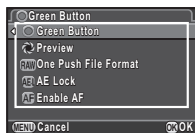



One of the following functions can be assigned to .





Setting	Function
Green Button	Resets the values being adjusted. (Default setting)
Preview	While  is pressed, you can check the depth of field by stopping down the aperture of the lens to the actually set value.
One Push File Format	Temporarily changes the file format regardless of the [File Format] setting. You can set whether to apply the setting to only one image or not, and select the file format when  is pressed.
AE Lock	The exposure setting is locked.
Enable AF	Autofocus is performed only when  is pressed and not when the shutter release button is pressed halfway.

Setting the One Push File Format

- 1 Select [One Push File Format] in [Green Button] of 3 menu.
- 2 Select or for [Cancel after 1 shot].

<input checked="" type="checkbox"/>	The recording format returns to the original file format after a picture is taken. (Default setting)
<input type="checkbox"/>	Settings are retained until any of the following operations is performed: <ul style="list-style-type: none">• When  is pressed again• When , ,  or power switch is pressed• When the mode dial is turned

- 3 For each file format, select the file format for when  is pressed.

The left side is the [File Format] setting and the right side is the file format when  is pressed.

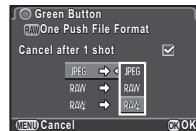

Setting the Operation in P Mode

Set the value to be changed with  when in **P** mode.

- 1 Select [Green Button] in [Green Button] of 3 menu.

2 Select [E-dial in Program] and change the setting.

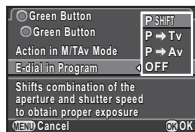

P SHIFT	Automatically adjusts the shutter speed and aperture value to obtain a proper exposure (Program Shift). (Default setting)
P → Tv	Adjusts the shutter speed (Shutter Priority Automatic Exposure).
P → Av	Adjusts the aperture value (Aperture Priority Automatic Exposure).
OFF	Disables the operation when turned in P mode.

Memo

- If is pressed after turning in **P** mode, the settings return to normal **P** mode.

Setting the Operation in M/TAv Mode

You can set the function of when in **M** or **TAv** mode.

- 1 Select [Green Button] in [Green Button] of 3 menu.
- 2 Select [Action in M/TAv Mode] and change the setting.

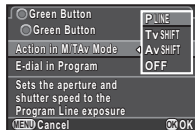

P LINE	Adjusts the aperture value and shutter speed to obtain a proper exposure according to the Program Line. (Default setting)
Tv SHIFT	Adjusts the shutter speed while the aperture value remains fixed.
Av SHIFT	Adjusts the aperture value while the shutter speed remains fixed.
OFF	Disables the operation when pressed in M or TAv mode.

Saving the Settings of a Captured Image

If you take an image that you like, you can save the settings used in that image to make it even easier to replicate the look of the image.

- 1 Display the image to edit in single image display of playback mode.
- 2 Select in the playback mode palette. The screen for changing the settings appears.
- 3 Save the White Balance, Custom Image and Digital Filter settings as necessary. Select [-] to not save a setting.



Available operations

- Changes the function.
- Changes the value.
- Selects a different image.
- Resets the adjustment value to the default setting.

4 Press **OK**.

The save confirmation screen appears.

5 Select a **USER mode number** and press **OK**.

The selected image along with the settings used in that image are saved in USER1 to 3.



Using the Saved Settings

You can load and use the saved settings when taking pictures.

1 Select **[Quick Dial]** in **Q3** menu.

2 Select **[Smart Effect]** in **[Quick Dial]** screen.

3 Save **USER1**, **USER2**, and **USER3** to any of the dial positions 1 to 4.

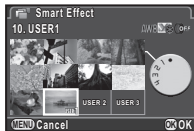

4 In standby mode, set the quick dial to the position 1 to 4.

The shooting settings saved in the selected position is loaded.

Memo

- Refer to p.48 for details about Quick Dial.

Displaying the Local Date and Time of the Specified City



1

The date and time set in Initial Setting (p.25) serve as the date and time of your present location and are reflected in the shooting date and time for images.

Setting the destination to a location other than your present location enables you to display the local date and time on the monitor when traveling abroad and also save images time-stamped with the local date and time.

1 Select **[World Time]** in **1** menu.

2 Select the time you wish to display in **[Time Setting]**.

Select  (Hometown) or  (Destination).

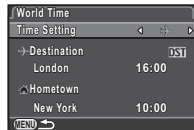

3 Press **▼** to select **[→ Destination]** and press **▶**.

The **[→ Destination]** screen appears.

4 Use **◀▶** to select a city.

Use  to change the region.

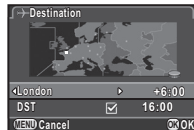

5 Press **▼** to select **[DST]** (daylight saving time), and use **◀▶** to select or .

6 Press **OK**.

The **[World Time]** screen reappears.

Memo

- Refer to “List of World Time Cities” (p.82) for cities that can be selected as a hometown or destination.
- Select [Hometown] in Step 3 to change the city and DST settings for the hometown.
- appears in the control panel and guide display if [Time Setting] is set to . Also, the video output setting changes to the video output format for that city.

Selecting Settings to Save in the Camera 3

Most of the functions set on this camera are saved even if the camera is turned off. For the following function settings, you can select whether to save the settings () or to return the settings to their default values () when the camera is turned off. Set in [Memory] of the 3 menu.

Function	Default Setting
Flash Mode	<input checked="" type="checkbox"/>
Drive Mode	<input checked="" type="checkbox"/>
White Balance	<input checked="" type="checkbox"/>
Custom Image	<input checked="" type="checkbox"/>
Sensitivity	<input checked="" type="checkbox"/>
EV Compensation	<input checked="" type="checkbox"/>

Function	Default Setting
Flash Exposure Compensation	<input checked="" type="checkbox"/>
Focus Position	<input type="checkbox"/>
Digital Filter	<input type="checkbox"/>
HDR Capture	<input type="checkbox"/>
Playback Info Display	<input checked="" type="checkbox"/>

Memo

- When [Reset] of the 3 menu is performed, all Memory settings return to the default values.

File Management Settings

Protecting Images from Deletion (Protect)

You can protect images from being accidentally deleted.

Caution

- Even protected images are deleted if the inserted memory card is formatted.

1 Select in the playback mode palette.
The screen for selecting the unit for processing appears.

2 Select the unit and press .
If you selected [All images], proceed to Step 4.

3 Use to select an image.



4 Select [Protect] and press .
Repeat Steps 3 and 4 to protect other images.

5 Press to finish the setting.

Folder

When images are captured with this camera, a folder is automatically created and the captured images are stored in the new folder. Each folder name consists of a sequential number from 100 to 999 and a string of 5 characters. You can change the folder name in [Folder Name] of the menu.

Date	The two digits of the month and day on which the picture was taken are assigned after the folder number. (Default setting) [MMDD] appears according to the date format set in [Date Adjustment]. Example) 101_0125: for images taken on January 25th
PENTX	The character string "PENTX" is assigned after the folder number. Example) 101PENTX

A folder with a new number is created when the folder name is changed.

Memo

- A maximum of 500 images (100 images for Eye-Fi card) can be stored in a single folder. When the number of captured images exceeds 500, a new folder is created with the number following the number of the folder currently being used. In Exposure Bracketing shooting, images will be stored in the same folder until shooting is completed.
- When [Create New Folder] is selected in the menu, a folder is created with the number following the number of the folder currently being used. Only one folder can be created using this feature. Multiple empty folders cannot be created consecutively.

- When [Develop multiple images] or [Develop images in folder] of [RAW Development] is performed, a "xxxR_JPG" folder with a new number is created, and the JPEG images are stored in the new folder. (p.60)

Caution

- The maximum folder number is 999. After the folder number reaches 999, you cannot capture new images if you attempt to change the folder name or create a new folder, or when the file name number reaches 9999.

File No.

Each file name consists of a string of 4 characters and a sequential number from 0001 to 9999. You can set whether to continue the sequential numbering for the file name even if a new folder is created in [Sequential Numbering] of [File No.] in the menu.

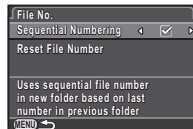

<input checked="" type="checkbox"/>	Continue the sequential numbering for the file name even if a new folder is created. (Default setting)
<input type="checkbox"/>	The file number of the first image saved to a folder returns to 0001 each time a new folder is created.

Select [Reset File Number] to reset the file number to its default setting.

Memo

- When the file number reaches 9999, a new folder is created and the file number is reset.
- One of the following string of characters is used as the file name prefix depending on the [13. Color Space] setting of the menu.

Color Space	File Name
sRGB	IMGFxxx.JPG
AdobeRGB	_IMGxxx.JPG

Transferring Images via Wireless LAN



You can transfer images to your computer via wireless LAN by using a memory card with a built-in wireless LAN (Eye-Fi card). Select the camera action when using an Eye-Fi card in [Eye-Fi Communication] of [Eye-Fi] in the menu.

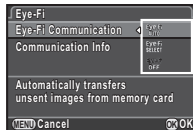

Auto	Transfers automatically when images are taken, new images are saved, or images are overwritten. Only movies under 2 GB can be transferred.
Select	Transfers images that are selected in playback mode. Only JPEG and RAW images can be transferred.
Off	Turns off the wireless LAN function. (Default setting)

⚠ Caution

- Be sure to set up a wireless LAN access point on a computer for the Eye-Fi card connection.
- For RAW images and movie files, the success of transfer depends on the specifications and settings of the Eye-Fi card in use.
- Images may not be transferred when the battery level is low.
- It may take time to transfer a large number of images. The camera may turn off if the internal temperature of the camera becomes high.
- For precautions on the Eye-Fi card, refer to "About Eye-Fi Cards" (p.91).

📝 Memo

- [Eye-Fi] of the menu cannot be selected when an Eye-Fi card is not inserted.

- When an Eye-Fi card is used, 100 images can be stored in a single folder. For RAW+ images, two files are counted as one image.
- Select [Communication Info] to check the firmware version of the Eye-Fi card.

Transferring Selected Images

You can select the images to transfer.

- 1** Set [Eye-Fi Communication] to [SELECT] in [Eye-Fi] of menu.
- 2** Select in the playback mode palette. The screen for selecting a transfer option appears.
- 3** Select the desired option and press **OK**.

Select image(s)	Up to 100 images can be selected in one folder.
Select a folder	Transfers all images that can be transferred in the selected folder.



The folder selection screen appears.

- 4** Select a folder and press **OK**. The image selection screen appears. When [Select a folder] is selected, proceed to Step 7.
- 5** Select the image(s) to transfer.

Images that have already been transferred and movies cannot be selected.



Available operations

▲▼◀▶	Moves the selection frame.
	Shows the single image display.
	Confirms/cancels the image selection.

6 Press .

The confirmation screen appears.

7 Select [Transfer] and press .

The single image display reappears after an operation message is displayed.

Setting Print Information (DPOF)

The DPOF settings (number of copies and whether to imprint the date on images) can be added to the stored images on the memory card. By taking this card to a store for printing, you can order conventional photo prints.

1 Select  in the playback mode palette.

The screen for selecting a DPOF setting option appears.



2 Select the desired option and press .

Single image	Applies the DPOF settings to each individual image.
All images	Applies the same DPOF settings to all the images, and cancels the settings specified for each individual image.

3 Select the number of copies and date setting.

You can specify the desired DPOF settings for multiple images.

**Available operations**

	Selects a different image (when [Single image] is selected).
▲▼	Specifies the number of copies.
	Switches selecting or canceling the check box for printing the date.

 appears for images with DPOF settings.

4 Press .** Memo**

- The DPOF settings cannot be set for RAW images and movies.
- You can set the DPOF settings for up to 999 images.

Restrictions on Each Capture Mode

#: Restricted x: Not available

Capture Mode		AUTO	SCN										BC	Bulb	⊞		
Function																	
Sensitivity		AUTO*1	AUTO*1	AUTO*1	AUTO*1	AUTO*1	x	AUTO*1	AUTO*1	AUTO*1	AUTO*1	AUTO*1	AUTO*1		- ISO 1600		
Flash		*2	*2	x	*2	*2	x	*2	*2	x	*2	x	x			x	
Drive Mode	Single Frame Shooting					x				x	x					x	
	Continuous Shooting					*3	x		x	*3	*3			x	x	x	
	Self-timer Shooting					x				x	x					x	
	Remote Control	0 sec./ 3 sec.					x				x	x					
		Continuous Shooting					x	x		x	x	x			x	x	x
	Exposure Bracketing						x	x		x	x	x			x	x	x
	Multi-exposure						x	x		x	x	x			x		x
Interval Shooting						x	#		x	x	x			x	x		
Focus Method		*1	*1			*1		*1		*1	*1	*1					
File Format	RAW/RAW+						x		x							x	
Shake Reduction							x									x	

Capture Mode Function	AUTO	SCN											BC	Bulb		
							HDR									
White Balance	AWB ^{*1}	AWB ^{*1}	AWB ^{*1}	AWB ^{*1}	AWB ^{*1}	AWB ^{*1}	AWB ^{*1}	AWB ^{*1}	AWB ^{*1}	AWB ^{*1}	AWB ^{*1}	AWB ^{*1}				
Custom Image	×	×	×	×	×	×	×	×	×	×	×	×				
Digital Filter						×										
Smart Effect																
HDR Capture						*4		×						×	×	×
Save RAW Data					×	×			×	×						×

*1 Fixed to; the setting cannot be changed.

*2 Limited to; available settings are limited.

*3 Fixed to; for JPEG, for RAW/RAW

*4 Specific settings are used.

Restrictions on the Combinations of Special Functions

x: Not available

		Continuous Shooting	Exposure Bracketing	Multi-exposure	Interval Shooting	Digital Filter	Smart Effect	HDR Capture
Flash								x
Drive Mode	Continuous Shooting		x	x	x			x
	Self-timer Shooting	x	x	x	x			
	Remote Continuous Shooting	x	x	x	x			x
	Exposure Bracketing	x		x	x			x
	Multi-exposure	x	x		x	x	x	x
	Interval Shooting	x	x	x				
File Format	RAW/ RAW+	Ⓜ ^{*1}		x				x
Custom Image							x	
Digital Filter				x			x	x
Smart Effect				x		x		x
Save RAW Data		x	x	x				x

*1 Fixed to; the setting cannot be changed.

Functions Available with Various Lenses

A group	01 STANDARD PRIME 02 STANDARD ZOOM 06 TELEPHOTO ZOOM
B group	04 TOY WIDE 05 TOY TELEPHOTO 07 MOUNT SHIELD
C group	03 FISH-EYE
D group	ADAPTER Q FOR K MOUNT LENS

✓: Available #: Restricted X: Not available

Lens Type	A group	B group	C group	D group
Function				
AF	✓	X	X	X
MF	✓	✓ ^{*1}	✓	✓
Quick-shift focus	✓	X	X	X
Autofocus Method	✓	X	X	X
Aperture control	✓	X	X	# ^{*2}
ND filter on the lens	✓	X	X	X
Shutter on the lens	✓	X	X	✓ ^{*3}
Electronic shutter	✓ ^{*4}	✓	✓	✓ ^{*4}
AUTO/SCN/BC mode	✓	# ^{*5}	# ^{*5}	# ^{*2}
P/Tv/Av mode	✓	# ^{*5}	# ^{*5}	# ^{*2}
M mode	✓	# ^{*5} *6	# ^{*5} *6	# ^{*2}
 mode	✓	# ^{*5}	# ^{*5}	# ^{*2}
P-TTL auto flash	✓ ^{*7}	✓ ^{*8}	# ^{*8} *9	# ^{*8} *10

- *1 No focusing mechanism on 07 MOUNT SHIELD
- *2 Set the aperture manually.
- *3 Lens shutter built-in to the adapter used.
- *4 Set [1. Lens Shutter Options] to [Lens and electronic shutters] or [Electronic shutter only] in the **C1** menu. When [Lens and electronic shutters] is selected, you can take pictures at higher speeds with the electronic shutter than with the lens shutter. Ex.) With a 01 STANDARD lens
Pictures are taken at 1/2000 sec. or slower with the lens shutter and 1/2000 sec. or faster with the electronic shutter.
- *5 Aperture value fixed.
- *6 **Bulb** mode is not available. Allows the use of a slow shutter speed of up to 2 sec.
- *7 Built-in flash: 1/2000 sec., external flash: 1/250 sec.
- *8 Flash sync speed is approx. 1/13 sec.
- *9 Light is unevenly distributed.
- *10 Light may be unevenly distributed.

Compatibility with the Built-in Flash

Depending on the lens being used, the use of the built-in flash may be limited.

Lens	Restrictions when using the built-in flash
02 STANDARD ZOOM	If the focal length is less than 6 mm, vignetting may occur at the wide-angle setting.
03 FISH-EYE	The built-in flash is not available due to vignetting.

About Hoods

When using a hood with a 02 STANDARD ZOOM lens, be sure to use the PH-RBB 40.5mm. If the PH-SBA 40.5mm is used, vignetting may occur at the wide-angle setting.

About Filters

Vignetting will occur at the wide-angle setting if a PL100 filter is used with a 02 STANDARD ZOOM lens.

Using a K-Mount Lens

A K-mount lens can be attached to this camera with the use of the optional Adapter Q for K Mount Lens. When a K-mount lens is used, the focal length must be set manually for some functions such as Shake Reduction, since the focal length cannot be obtained automatically.

1 Turn the camera off.

2 Attach the adapter and lens to the camera, and turn the camera on.

The [Input Focal Length] screen appears.

3 Set the lens focal length.



Available operations

▲ ▼ Changes the value of each digit.

◀ ▶ Selects a digit.

☰ Selects a value from the list.

When using a zoom lens, select the actual focal length which the zoom is set to.

4 Press **OK**.

The camera returns to standby mode.

Memo

- The focal length setting can be changed in [Input Focal Length] of the **2** menu.
- When the Adapter Q for K Mount Lens is used, the camera operates in **Av** mode when the capture mode is set to other than **M** mode.
- Refer to the Adapter Q for K mount lens manual for details.

Functions when Using an External Flash

Using an optional external flash AF540FGZ, AF360FGZ, AF200FG or AF160FC enables a variety of flash modes, such as P-TTL auto flash mode.

✓ : Available X : Not available

Camera Function \ Flash	Built-in flash	AF540FGZ AF360FGZ	AF200FG AF160FC
Red-eye reduction flash	✓	✓	✓
Auto Flash Discharge	✓	✓	✓
Automatically switching to the flash sync speed	✓	✓	✓
Aperture value is automatically set in P mode and Tv mode.	✓	✓	✓
P-TTL auto flash	✓	✓	✓
Slow-speed Sync	✓	✓	✓
Flash Exposure Compensation	✓	✓	✓
Auto zoom flash head	X	✓	X
AF assist light of external flash	X	X	X
Trailing Curtain Sync *1	✓	✓	X
Contrast control sync flash mode	X	X	X
Slave flash	X	X	X
Wireless flash	X	X	X

*1 1/2000 sec. or slower for a 01 STANDARD PRIME/02 STANDARD Zoom/06 TELEPHOTO ZOOM lens (1/250 sec. or slower for external flash units), 1/13 sec. or slower for a 03 FISH-EYE/04 TOY WIDE/05 TOY TELEPHOTO/07 MOUNT SHIELD lens.

⚠ Caution

- The built-in flash will not discharge if the camera is connected to an external flash.
- Combining with flashes from other manufacturers may cause equipment breakdown.

📌 Memo

- When an external flash is attached directly to the hot shoe of the camera, the camera's center of gravity is shifted, making it difficult to take pictures. Attach the Hot Shoe Adapter Fg (optional) to the camera hot shoe and an Off-Camera Shoe Adapter F (optional) to the bottom of the external flash, and connect these with the Extension Cord F5P (optional) as shown in the illustration. The Off-Camera Shoe Adapter F can be mounted to your tripod using the tripod screw.

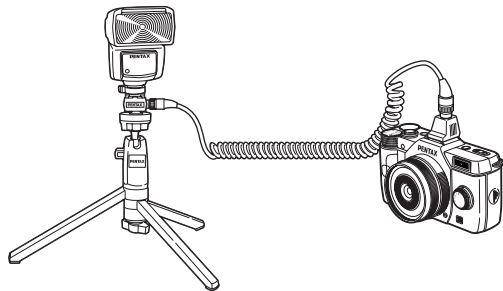

- To use an AF160FC flash with the camera, a commercially available step-up ring or similar accessory is needed.



Troubleshooting

Memo

- In rare cases, the camera may not operate correctly due to static electricity. This can be remedied by taking the battery out and putting it back in again. If the camera operates correctly, it does not require any repairs.

Problem	Cause	Remedy
The camera does not turn on.	Battery is not installed properly.	Check the orientation of battery.
	The battery power is low.	Charge the battery.
The shutter cannot be released.	The built-in flash is charging.	Wait until charging is finished.
	There is no available space on the memory card.	Insert a memory card with available space or delete unwanted images.
	Data being processed.	Wait until processing is finished.
Autofocus does not work.	The subject is difficult to focus on.	AF cannot work well for low-contrast objects (the sky, white walls, etc.), dark colors, intricate designs, rapidly-moving objects or scenery shot through a window or a net-like pattern. Lock focus on another object located at the same distance as your subject, then aim at the target and take a picture. Alternatively, use MF . (p.37)
	The subject is too close.	Move away from the subject and take a picture.

Problem	Cause	Remedy
The focus cannot be locked.	[Autofocus Method] is set to .	Set [Autofocus Method] to , or . (p.36)
	The capture mode is set to , , or of SCN mode.	[Autofocus Method] is fixed to in these modes. Set a capture mode other than those shown to the left.
The built-in flash does not discharge.	When the flash mode is set to or , the flash will not discharge if the subject is bright.	Change the flash mode. (p.34)
	The capture mode is set to , , , , , , , , or of SCN mode.	The flash mode is fixed to in these modes. Set a capture mode other than those shown to the left.
The camera is not recognized when it is connected to a computer.	The USB connection mode is set to [PTP].	Set [USB Connection] to [MSC] in [Interface Options] of the 2 menu.
The shooting settings cannot be changed.	The quick dial is set to the position 1 to 4.	When you use the quick dial to take pictures, priority is given to the settings saved in the quick dial.

Problem	Cause	Remedy
Dust or dirt particles appear in images.	The CMOS sensor is dirty or dusty.	Activate [Dust Removal] from the  4 menu. The Dust Removal function can be activated every time the camera is turned on and off. Use a brush-less blower to remove dirt and dust from the CMOS sensor. Using a blower with a brush may scratch the CMOS sensor. Do not wipe the CMOS sensor with a cloth.
There are pixels in the monitor that do not light up or remain lit.	There are defective pixels in the CMOS sensor.	Attach a lens cap to a lens that has a lens shutter, such as the 01 STANDARD PRIME, and perform [Pixel Mapping] of the  4 menu. It takes about 30 seconds to correct the defective pixels, so be sure to install a fully charged battery.

Error Messages

Error Messages	Description
Memory card full	The memory card is full and no more images can be saved. Insert a new memory card or delete unwanted files.
No image	There are no images that can be played back on the memory card.
This image cannot be displayed	You are trying to play back an image in a format not supported by this camera. You may be able to play it back on a computer.
No card in the camera	There is no memory card inserted in the camera.
Memory card error	The memory card has a problem, and image capture and playback are impossible. You may be able to play it back on a computer. Failed to initialize Eye-Fi function when using the Eye-Fi card. Press  .
Card is not formatted	The memory card you have inserted is unformatted or has been used on another device and is not compatible with this camera. Use the card after formatting it with this camera.
Card is locked	The write-protect switch on the memory card you have inserted is locked. (p.90)
This image cannot be magnified	You are trying to magnify an image that cannot be magnified.
This image is protected	You are trying to delete an image that is protected. Remove protection from the image. (p.65)

Error Messages	Description
Not enough battery power remaining to activate Pixel Mapping	Appears during Pixel Mapping or when trying to update the firmware if the battery level is insufficient. Install a fully charged battery.
Not enough battery power remaining to update the firmware	
Unable to update firmware. There is a problem with the firmware update file	Unable to update the firmware. The update file is damaged. Try downloading the update file again.
Image folder cannot be created	The maximum folder number (999) and file number (9999) are being used, and no more images can be saved. Insert a new memory card or format the card.
Unable to store image	The image could not be saved because of a memory card error.
Settings not stored	The DPOF settings could not be saved because the memory card is full. Delete unwanted images and perform DPOF setting again. (p.68)
The operation could not be completed correctly	The camera was unable to adjust the manual white balance. Try the operation again.
No more images can be selected	You cannot select more than the maximum number of images for Index, Select & Delete, RAW Development, Select image(s) for Eye-Fi, and DPOF.
No image can be processed	There are no images that can be processed using Digital Filter or RAW Development function.

Error Messages	Description
This image cannot be processed	Appears when you try to perform Resize, Cropping, Red-eye Edit, Digital Filter, Movie Edit, RAW Development, Save as Manual WB, or Save Smart Effect for images captured with other cameras, or when you try to perform Resize or Cropping for minimum file size images.
The camera failed to create an image	The creation of an index print image failed.
This function is not available in the current mode	You are trying to set a function that is not available for the capture mode that is set. (p.69)
The camera will turn off to prevent damage from overheating	The camera will turn off because its internal temperature gets too hot. Leave the camera turned off until it has had time to cool down before turning on the camera again.
Set the Eye-Fi communication to "SELECT"	Images cannot be transferred when [Eye-Fi Communication] is not set to [SELECT] in [Eye-Fi] of the  menu. (p.67)
Image not found	There are no images that can be transferred when an Eye-Fi card is used.
Cannot be selected	This folder cannot be selected because the number of files exceeds the maximum number allowed. (p.67)

Main Specifications

Model Description

Type	Lens-interchangeable SL digital camera
Lens Mount	PENTAX bayonet Q-mount
Compatible Lens	Q-mount lenses

Image Capture Unit

Image Sensor	Type: CMOS sensor with a primary color filter Size: 1/1.7-inch
Effective Pixels	Approx. 12.4 megapixels
Total Pixels	Approx. 12.76 megapixels
Dust Removal	Image sensor cleaning using ultrasonic vibrations "DR II"
Sensitivity (Standard Output)	ISO AUTO: ISO 100 to ISO 12800 (1/3 EV steps) • Up to ISO 1600 when the shutter speed is set to 2 sec. or slower.
Image Stabilizer	Sensor shift Shake Reduction

File Format

Recording Formats	RAW (DNG), JPEG (Exif 2.3), DCF 2.0 compliant
Recorded Pixels	JPEG: 16:9 L 9M (4000×2248) M 5M (3072×1728) S 2M (1920×1080) 3:2 L 10M (4000×2664) M 6M (3072×2048) S 2M (1920×1280) 4:3 L 12M (4000×3000) M 7M (3072×2304) S 3M (1920×1440) 1:1 L 9M (2992×2992) M 5M (2304×2304) S 2M (1440×1440)
	RAW: 4:3 L 12M (4000×3000)

Quality Level	RAW: DNG (12 bit) JPEG: ★★★ (Best), ★★ (Better), ★ (Good) • RAW and JPEG simultaneously recordable
Color Space	sRGB, AdobeRGB
Storage Media	SD Memory Cards, SDHC Memory Cards, SDXC Memory Cards and Eye-Fi Cards
Storage Folder	Date (100_1018, 100_1019...)/ PENTX (100PENTX, 101PENTX...)

Monitor

Type	TFT color LCD monitor, wide angle viewing, with AR coating
Size	3.0 inches
Dots	Approx. 460,000 dots
Adjustment	Brightness and colors adjustable
Display	Field of View: approx. 100%, Electronic Level, Grid Display (4 × 4 Grid, Golden Section, Scale), Highlight Alert, Histogram

White Balance

Auto	TTL by CMOS image sensor
Preset	Daylight, Shade, Cloudy, Fluorescent Light (D : Daylight Color, N : Daylight White, W : Cool White, L : Warm White), Tungsten, Flash, CTE , Manual
Manual	Configuration on monitor (3 types can be saved), configuration on captured image
Fine Adjustment	Adjustable ±7 steps on A-B axis and G-M axis

Focusing Mechanism

Type	Contrast detection AF
Brightness Range	EV 0 to 18 (ISO100)
Focus Method	AF/MF switching
Autofocus Method	Face Detection, Tracking, Multiple AF Points (49 Points), Select, Spot
AF Assist Light	Dedicated LED AF assist light
MF Autozoom	Off/×2/×4/×6

Exposure Control

Type	TTL image sensor metering Metering modes: Multi-segment metering, Center-weighted metering, and Spot metering
Metering Range	EV 1 to 17 (ISO 100, F1.9 lens), +2 EV with Electronic Shutter enabled, +2 EV with an ND filter
Exposure Modes	Auto Picture modes: Standard, Portrait, Landscape, Macro, Night Scene Portrait, Sunset, Blue Sky, Forest Scene modes: Portrait, Landscape, Macro, Moving Object, Night Scene Portrait, Sunset, Blue Sky, Forest, Night Scene, Night Scene HDR*, Night Snap, HDR*, Quick Macro*, Food, Pet, Kids, Surf & Snow, Backlight Silhouette, Candlelight, Stage Lighting, Museum Program, Shutter Priority, Aperture Priority, Manual, Bulb, Blur Control* *JPEG only
EV Compensation	± 3 EV (1/3 EV steps)
AE Lock	Can be assigned to the O button from the menu.
Shutter	Lens shutter: 1/2000 - 30 seconds (1/3 EV step, 1/8000 - 30 seconds with Electronic Shutter enabled), Bulb • When using a lens that has no lens shutter; shooting at 1/8000 - 2 seconds with the electronic shutter is available, Bulb shooting is not available.
Aperture	From wide open to F8 • Aperture is fixed when using a lens that has no lens shutter.
ND Filter	Off/On • Not available when using a lens that has no lens shutter.

Drive Modes

Mode Selection	Single frame, Continuous (Hi, Lo), Self-timer (12s, 2s), Remote Control (0 sec., 3 sec., continuous), Exposure Bracketing (3 frames, remote control), Multi-exposure (Multi-exposure, Self-timer+Multi-exposure, Remote Control+Multi-exposure), Interval Shooting
----------------	--

Continuous FPS	Approx. 5 fps, JPEG (4:3 □ 12M/★★★/Continuous Hi): up to 5 frames Approx. 1.5 fps, JPEG (4:3 □ 12M/★★★/Continuous Lo): up to 100 frames
----------------	--

Built-in Flash









Type	Built-in retractable P-TTL flash, Guide number: approx. 4.9 (ISO100/m), approx. 7 (ISO200/m) Angle of view coverage: equivalent to 28 mm in 35 mm format
Flash Modes	P-TTL, Red-eye Reduction, Slow-speed Sync, Trailing Curtain Sync
Sync Speed	Lens shutter: built-in flash 1/2000 seconds, Used with external flash units: 1/250 seconds, Electronic shutter: 1/13 seconds
Flash Exposure Compensation	-2.0 to +1.0 EV

Capture Functions

Custom Image	Bright, Natural, Portrait, Landscape, Vibrant, Radiant, Muted, Bleach Bypass, Reversal Film, Monochrome, Cross Processing
Noise Reduction	High-ISO NR
Dynamic Range Setting	Highlight Correction, Shadow Correction
Lens Correction	Distortion Correction
Digital Filter	Toy Camera, High Contrast, Shading, Tone Expansion, Invert Color, Extract Color, Unicolor Bold, Water Color, Posterization, Slim, Fish-eye
HDR Capture	Auto, HDR 1, HDR 2
Multi-exposure	Number of shots: 2-9 Exposure adjusted automatically.
Interval Shooting	Shooting interval: 3 sec. to 24 hr., Start Interval setting: immediately, from the set time, Number of shots: up to 999 images

Smart Effect	Brilliant Color, Unicolor Bold, Vintage Color, Cross Processing, Warm Fade, Tone Expansion, Bold Monochrome, Water Color, Vibrant Color Enhance, USER 1-3
Electronic Level	Displayed on LCD monitor (horizontal and vertical directions)

Movies

Recording Format	MPEG-4 AVC/H.264 (.MOV)						
Recorded Pixels	<table border="0"> <tr> <td></td> <td>(1920×1080, 16:9, 30 fps/25 fps/24 fps)</td> </tr> <tr> <td></td> <td>(1280×720, 16:9, 30 fps/25 fps/24 fps)</td> </tr> <tr> <td></td> <td>(640×480, 4:3, 30 fps/25 fps/24 fps)</td> </tr> </table>		(1920×1080, 16:9, 30 fps/25 fps/24 fps)		(1280×720, 16:9, 30 fps/25 fps/24 fps)		(640×480, 4:3, 30 fps/25 fps/24 fps)
	(1920×1080, 16:9, 30 fps/25 fps/24 fps)						
	(1280×720, 16:9, 30 fps/25 fps/24 fps)						
	(640×480, 4:3, 30 fps/25 fps/24 fps)						
Sound	Built-in monaural microphone; recording sound level can be adjusted.						
Recording Time	Up to 25 minutes; automatically stops recording if the internal temperature of the camera becomes high.						
Custom Image	Bright, Natural, Portrait, Landscape, Vibrant, Radiant, Muted, Bleach Bypass, Reversal Film, Monochrome, Cross Processing						
Digital Filter	Toy Camera, High Contrast, Shading, Tone Expansion, Invert Color, Extract Color, Unicolor Bold, Water Color, Posterization, Slim, Fish-eye						
Interval Movie Record	Recording format: Motion JPEG (.AVI) Recording interval: 3 sec., 5 sec., 10 sec., 30 sec., 1 min., 5 min., 10 min., 30 min., 1 hr. Recording time: 12 sec. to 99 hr. Start Interval: immediately, from the set time						

Playback Functions

Playback View	Single frame, multi-image display (4, 9, 30, and 56 thumbnails), display magnification (up to 16×, scrollable, quick zoom), rotating, histogram (Y histogram, RGB histogram), highlight alert, auto image rotation, detailed information display, folder display, calendar filmstrip display, slideshow, wireless image transfer with Eye-Fi
Delete	Single image, all images, select & delete, folder, instant review image

Digital Filter	Base Parameter Adj, Toy Camera, High Contrast, Shading, Tone Expansion, Invert Color, Extract Color, Unicolor Bold, Water Color, Posterization, Slim, Fish-eye, Retro, Sketch, Miniature, Soft, Starburst
RAW Development	File Format (JPEG), Aspect Ratio, Color Space, White Balance, Custom Image, Digital Filter, Sensitivity, High-ISO NR, Shadow Correction, Distortion Correction
Edit	Resize, Cropping (aspect ratio adjustment available), Index, Movie Edit (divide or delete selected frames), Capturing a JPEG still picture from a movie, Red-eye Edit, Save the RAW file data in the buffer memory

Customization

Custom Functions	16 items
Mode Memory	11 items
Button/Dial Customization	● button: Green Button, Preview, One Push File Format, AE Lock, Enable AF Quick Dial: Smart Effect, Aspect Ratio, Focus Method, Focus Peaking, ND Filter
World Time	World Time settings for 75 cities (28 time zones)

Power Supply

Battery Type	Rechargeable Lithium-ion Battery D-LI68
AC Adapter	AC Adapter Kit K-AC115 (optional)
Battery Life	Number of recordable images (with 50% flash usage): approx. 250 images, (without flash usage): approx. 260 images Playback time: approx. 160 minutes • Tested in compliance with CIPA standard using a new rechargeable lithium-ion battery under the temperature of 23°C. Actual results may vary depending on the shooting conditions/circumstances.

Interfaces

Connection Port	USB 2.0 (high-speed compatible)/AV output terminal, HDMI output terminal (Type D)
USB Connection	MSC/PTP
Video Output Format	NTSC/PAL

Dimensions and Weight

Dimensions	Approx. 102.0 mm (W) × 58.0 mm (H) × 33.5 mm (D) (excluding the operation parts and protrusion)
Weight	Approx. 200 g (loaded and ready with the dedicated battery and SD Memory Card), Approx. 180 g (body only)

Accessories

Package Contents	USB Cable I-USB7, Strap O-ST131, Rechargeable Lithium-ion Battery D-LI68, Battery Charger D-BC68P, AC plug cord, Software (CD-ROM) S-SW133 <Mounted on the camera> Hot shoe cover FK, Body mount cover
Software	SILKYPIX Developer Studio 3.0 LE

Approximate Image Storage Capacity and Playback Time

(When using the fully charged battery)

Battery	Temperature	Normal Shooting	Flash Photography		Playback Time
			50% Use	100% Use	
D-LI68	23°C	260	250	240	160 minutes

- The image storage capacity (normal recording and flash use 50%) is based on measuring conditions in accordance with CIPA standards, while other data is based on our measuring conditions. Some deviation from the above figures may occur in actual use depending on the selected capture mode and shooting conditions.

Approximate Image Storage Capacity by Size

(When using a 2 GB memory card)

Aspect Ratio	Recorded Pixels	JPEG Quality			RAW
		★★★	★★	★	
16:9	L 9M	545	755	1265	103
	M 5M	908	1250	2060	–
	S 2M	2184	2941	4600	–
3:2	L 10M	461	641	1077	103
	M 6M	771	1064	1764	–
	S 2M	1872	2534	4013	–
4:3	L 12M	410	571	961	103
	M 7M	688	951	1582	–
	S 3M	1680	2282	3641	–
1:1	L 9M	547	759	1270	103
	M 5M	908	1250	2060	–
	S 2M	2184	2941	4600	–

- The number of storable images may vary depending on the subject, shooting conditions, selected capture mode and memory card, etc.

List of World Time Cities

Region	City	Video Output Format
North America	Honolulu	NTSC
	Anchorage	NTSC
	Vancouver	NTSC
	San Francisco	NTSC
	Los Angeles	NTSC
	Calgary	NTSC
	Denver	NTSC
	Chicago	NTSC
	Miami	NTSC
	Toronto	NTSC
	New York	NTSC
Halifax	NTSC	
Central and South America	Mexico City	NTSC
	Lima	NTSC
	Santiago	NTSC
	Caracas	NTSC
	Buenos Aires	PAL
	Sao Paulo	PAL
	Rio de Janeiro	NTSC
Europe	Lisbon	PAL
	Madrid	PAL
	London	PAL
	Paris	PAL
	Amsterdam	PAL
	Milan	PAL

Region	City	Video Output Format
Europe	Rome	PAL
	Copenhagen	PAL
	Berlin	PAL
	Prague	PAL
	Stockholm	PAL
	Budapest	PAL
	Warsaw	PAL
	Athens	PAL
	Helsinki	PAL
	Moscow	PAL
	Africa/ West Asia	Dakar
Algiers		PAL
Johannesburg		PAL
Istanbul		PAL
Cairo		PAL
Jerusalem		PAL
Nairobi		PAL
Jeddah		PAL
Tehran		PAL
Dubai		PAL
Karachi		PAL
Kabul		PAL
Male		PAL
Delhi		PAL
Colombo	PAL	

Region	City	Video Output Format
Africa/ West Asia	Kathmandu	PAL
	Dacca	PAL
East Asia	Yangon	NTSC
	Bangkok	PAL
	Kuala Lumpur	PAL
	Vientiane	PAL
	Singapore	PAL
	Phnom Penh	PAL
	Ho chi Minh	PAL
	Jakarta	PAL
	Hong Kong	PAL
	Beijing	PAL
	Shanghai	PAL
	Manila	NTSC
	Taipei	NTSC
	Seoul	NTSC
	Tokyo	NTSC
Guam	NTSC	
Oceania	Perth	PAL
	Adelaide	PAL
	Sydney	PAL
	Noumea	PAL
	Wellington	PAL
	Auckland	PAL
	Pago Pago	NTSC

Operating Environment for USB Connection and Provided Software

With the provided software "SILKYPIX Developer Studio 3.0 LE", you can develop RAW files on a computer. Install the software from the provided CD-ROM (S-SW133). We recommend the following system requirements to connect the camera to a computer or to use the software.

Windows

OS	Windows XP (SP3 or later, 32-bit Home/Pro), Windows Vista (32-bit, 64-bit), Windows 7 (32-bit, 64-bit), Windows 8 (32-bit, 64-bit) <ul style="list-style-type: none">• Installation requires administrator rights• Can be run as a 32-bit application on any 64-bit Edition of Windows
CPU	Intel Pentium-compatible processor (Pentium 4, Athlon XP or higher recommended) <ul style="list-style-type: none">• Supports multi-core processors (Intel Core i5, i7; Core 2 Quad, Duo; AMD Phenom II X4, X6; Athlon II X2, X4; and other)
RAM	1 GB minimum (2 GB or more recommended)
HDD	For installing and starting up the program: 100 MB minimum of free space For saving image files: Approx. 10 MB/file
Monitor	1024×768 dots, 24-bit full color or higher
Other	Input devices such as a keyboard and mouse



















Macintosh

OS	Mac OS X 10.5, 10.6, 10.7 or 10.8
CPU	Intel processor-compatible, Power PC
RAM	1 GB minimum (2 GB or more recommended)
HDD	For installing and starting up the program: 100 MB minimum of free space For saving image files: Approx. 10 MB/file
Monitor	1024×768 dots, 24-bit full color or higher
Other	Input devices such as a keyboard and mouse

Memo

- QuickTime is required to play back movies transferred to a computer. You can download it from the following site: <http://www.apple.com/quicktime/download/>

Symbols

 menu	15
 menu	17
 menu	17
 menu	17
C menu	19
 Portrait	29
 Landscape	29
 Macro	29
 Moving Object	29
 Night Scene Portrait... ..	29
 Sunset	29
 Blue Sky	29
 Forest	29
 Night Scene	29
 Night Scene HDR	29
 Night Snap	29
 Quick Macro	30
 Food	30
 Pet	30
 Kids	30
 Surf & Snow	30
 Backlight Silhouette... ..	30
 Candlelight	30
 Stage Lighting	30
 Museum	30
 mode	32

A

AC adapter	23
Action in M/TAv Mode	63

AE Lock	62
AE Metering	34
AE-L with AF Locked	19
AF	36
AF area	37
AF Assist Light	7, 36
AF frame	28
AF Release Options	36
AF with Remote Control... ..	40
AF/MF Settings	15
Aperture Priority Automatic Exposure	31
Aspect Ratio	43
Auto Image Rotation	53
AUTO mode	27, 29
Auto Picture modes	27, 29
Auto Power Off	25
Auto SR Off	39
Autofocus	36
Autofocus Method	36
AV device	54
Av mode	31
AWB in Tungsten Light	20

B

Backlight Silhouette 	30
Base Parameter Adj (Digital Filter)	57
Battery	22
Battery cover	7
BC mode	30

Bleach Bypass (Custom Image)	46
Blue Sky 	29
Blur Control mode	30
Bold Monochrome (Smart Effect)	48
Bracketing Order	41
Bright (Custom Image)	46
Brightness adjustment	45
Brightness histogram	12
Brilliant Color (Smart Effect)	48
Built-in flash	34
Bulb	32
Bulb Shooting	32

C













Calendar Filmstrip Display	52
Candlelight 	30
Capture mode	29
Card access lamp	7
Card cover	7
Center-weighted metering	34
Charging the battery	22
City names	25, 82
CMOS sensor	7
Color Space	20, 66
Computer	55
Connection cable	

cover	7, 23
Continuous playback	53
Continuous Shooting	39
Control panel	10, 13
Create New Folder	66
Cropping	56
Cross Processing	47
Cross Processing (Custom Image)	46
Cross Processing (Smart Effect)	48
Custom Image	46
Custom Image setting	46
Custom Setting menus	19

D

Date Adjustment	26
DC coupler	23
Delete	28
Delete All Images	17
Depth of field	32
Destination	64
Detailed Information Display	12
Developing RAW images	60
Dial indicator	27
Digital Filter	47, 57
Direct keys	13
Display Color	18
Display style selection	51

Displaying multiple images.....	51	Firmware	19	(Digital Filter)	47, 57	(Custom Image).....	46
Distortion Correction.....	16	Firmware Info/Options	19	High-ISO NR	34	Landscape ▲	29
DPOF	68	Fish-eye		Highlight Alert	16, 17	Language setting	25
D-Range Settings	45	(Digital Filter)	47, 57	Highlight Correction	45	Language/言語	25
Drive Mode	38	Flash.....	34, 74	Histogram Display	12, 16	LCD Display.....	18
DST	26	Flash compensation	35	Hometown	25, 64	LCD Display Settings.....	18
DST		Flash pop-up switch	35	Hot shoe	7	Lens	21, 72
(daylight saving time)	64	Flash When Retracted.....	35			Lens focal length	73
Dust Removal	76	Flicker Reduction.....	18	I		Lens information contacts ...	7
Dynamic range	45	Focus Method.....	36	Image Capture Settings... ..	43	Lens mount index	7, 21
E		Focus Peaking.....	38	Image finishing touch	46	Lens Shutter Options.....	72
E-dial in Program.....	63	Focus ring	37	Image storage capacity	81	Lens unlock button	21
Electronic Level	10, 16	Focus Ring in AF Mode... ..	36	Imprint the date	68	Link AE and AF Point	34
Electronic shutter	72	Focusing	36	Index.....	58	Live View	10, 16
Enable AF	62	Focus-priority.....	20	Initial settings.....	25		
Error messages	76	Folder Display	52	Initializing		M	
EV bar scale	31	Folder Name.....	66	a memory card	26	M mode.....	31
EV Compensation	31	Food 🍴.....	30	Input Focal Length.....	73	Macintosh	84
Exposure	33	Forest 🌲.....	29	Instant Review	16, 28	Macro 📷.....	29
Exposure Bracketing	41	Format	26	Interface Options	18, 54	Magnify	28
Exposure Modes	31	Framerate	43	Interval Movie Record	42	Manual Exposure.....	31
Exposure Setting	17, 32	Function Restrictions.....	69	Interval Shooting	42	Manual focus	37
External flash.....	74	G		Invert Color		Manual White Balance.....	44
Extract Color		Green Button	62	(Digital Filter)	47, 57	Memory.....	65
(Digital Filter)	47, 57	Grid Display	16	ISO sensitivity.....	33	Memory card.....	24
Eye-Fi card	24, 67	Guide Display	28			Menus	14
		Guide number	35	J		MF	37
				JPEG	43	MF Autozoom	37
F		H				Microphone.....	7
Face Detection		HDMI output format	54	K		Miniature (Digital Filter) ...	57
(Autofocus Method)	36	HDMI terminal	54	Kids 🧒	30	Mode dial	27
File Format	43	HDR	29	K-mount lens	73	Monitor display	9
File No.	66	HDR Capture.....	45			Monochrome	
Filter	47, 57	High Contrast		L		(Custom Image).....	46
				Landscape		Motion JPEG	42

Movie Edit.....	59	Playback mode.....	28	Charging.....	35, 39	Shadow Correction.....	45
Movie menu.....	17	Playback mode palette....	50	Release-priority.....	36	Shake Reduction.....	16
Movie mode.....	32	Portrait (Custom Image)....	46	Remote control receiver....	7	Shooting.....	27
Movie SR.....	17	Portrait 	29	Remote Control		Shooting Info Display	
Moving Object 	29	Posterization		shooting.....	40	selection screen.....	11
MSC.....	75	(Digital Filter).....	47, 57	Reset.....	19, 20, 66	Shutter & Aperture Priority	
Multi-exposure.....	41	Power.....	25	Resets the adjustment		Automatic Exposure.....	31
Multi-image display.....	51	Power Saving.....	19	value.....	20	Shutter Priority Automatic	
Multiple AF Points		Preview.....	32, 62	Resize.....	56	Exposure.....	31
(Autofocus Method).....	36	Print.....	68	Retro (Digital Filter).....	57	SILKYPIX Developer	
Multi-segment metering...	34	Print information.....	68	Reversal Film		Studio.....	61, 83
Museum 	30	Program Automatic		(Custom Image).....	46	Single Frame Shooting....	38
Muted (Custom Image)....	46	Exposure.....	31	RGB Histogram Display...	12	Single image display ...	11, 28
N		Protect.....	65	Rotating images.....	53	Sketch (Digital Filter).....	57
Natural (Custom Image)....	46	Provided software.....	83	S		Slideshow.....	53
ND Filter.....	16, 72	PTP.....	75	Save as Manual WB.....	44	Slim (Digital Filter).....	47, 57
Night Scene HDR 	29	Q		Save Menu Location.....	14	Smart Effect.....	49
Night Scene 	29	Quality Level.....	43	Save RAW Data.....	16, 28	Soft (Digital Filter).....	57
Night Scene Portrait 	29	Quick Dial.....	48, 64	Save Rotation Info.....	53	Sound.....	32
Night Snap 	29	Quick Macro 	30	Save Smart Effect.....	63	Sound Effects.....	18
Noise Reduction.....	34	Quick Zoom.....	17	Scene modes.....	29	Speaker.....	7
O		QuickTime.....	84	SCN mode.....	29	Specifications.....	78
One Push File Format.....	62	R		SD Memory Card.....	24	Spot	
Operating environment....	83	Radiant		Select		(Autofocus Method).....	36
P		(Custom Image).....	46	(Autofocus Method).....	36	Spot metering.....	34
P mode.....	31	RAW.....	43	Select & Delete.....	51	Stage Lighting 	30
PC/AV terminal.....	54	RAW Development.....	60	Self-timer.....	7	Standby mode.....	10
Pet 	30	Rec. Mode menus.....	15	Self-timer lamp.....	40	Starburst (Digital Filter)....	57
Pixel Mapping.....	76	Recordable time.....	32	Self-timer shooting.....	40	Sunset 	29
Playback Info Display		Recorded Pixels.....	43	Sensitivity.....	33	Surf & Snow 	30
selection screen.....	11	Recording Sound Level ...	17	Sensitivity Steps.....	34		
Playback menu.....	17	Red-eye Edit.....	57	Sequential Numbering....	66		
		Release While		Set-up menus.....	17		
				Shading			
				(Digital Filter).....	47, 57		

T

- TA**v mode..... 31
- Terminal cover..... 7
- Thumbnail display 28, 51
- Tone Expansion
(Digital Filter) 47, 57
- Tone Expansion
(Smart Effect) 48
- Toy Camera
(Digital Filter) 47, 57
- Tracking
(Autofocus Method) 36
- Tripod socket..... 7
- Tv** mode 31

U

- Unicolor Bold
(Digital Filter) 47, 57
- Unicolor Bold
(Smart Effect) 48
- Updating firmware 19
- USB 55
- USB Connection..... 75, 83
- USER 48, 64
- User registration 6

V

- Vibrant (Custom Image)... 46
- Vibrant Color Enhance
(Smart Effect) 48
- Video output format 54
- Video terminal 54
- Vintage Color
(Smart Effect) 48
- Volume label..... 27

W

- Warm Fade
(Smart Effect) 48
- WARRANTY POLICY..... 93
- Water Color
(Digital Filter) 47, 57
- Water Color
(Smart Effect) 48
- WB When Using Flash 44
- White Balance 43
- Windows 83
- Wireless LAN..... 67
- World Time 64

Z

- Zoom lens..... 28

For Using Your Camera Safely

We have paid close attention to the safety of this camera. When using this camera, we request your special attention regarding items marked with the following symbols.



Warning

This symbol indicates that ignoring this item could cause serious personal injuries.



Caution

This symbol indicates that ignoring this item could cause minor or medium personal injuries, or loss of property.

About the Camera



Warning

- Do not disassemble or modify the camera. High voltage areas are present inside the camera, with the risk of electric shock.
- If the camera interior is exposed due to dropping or otherwise damaging the camera, never touch the exposed portion. There is a risk of electric shock.
- Do not aim the camera at the sun or other strong light sources when taking pictures or leave the camera sitting in direct sunlight with the lens cap off. Doing so may cause the camera to malfunction or cause a fire.
- Do not look at the sun or other strong light sources through the lens. Doing so may lead to a loss of eyesight or cause vision to be impaired.
- If any irregularities occur during use, such as smoke or a strange odor, stop use immediately, remove the battery or the AC adapter, and contact your nearest service center. Continued use can cause a fire or electrical shock.



Caution

- Do not place your finger over the flash when discharging the flash. You may burn yourself.
- Do not cover the flash with clothing when discharging the flash. Discoloration may occur.
- Some portions of the camera heat up during use. There is a risk of low temperature burns when holding such portions for long periods.

- Should the monitor be damaged, be careful of glass fragments. Also, be careful not to allow the liquid crystal to get on your skin or in your eyes or mouth.
- Depending on your individual factors or physical condition, the use of the camera may cause itching, rashes or blisters. In case of any abnormality, stop using the camera and get medical attention immediately.

About the Battery Charger and AC Adapter



Warning

- Always use the battery charger and AC adapter exclusively developed for this camera, with the specified power and voltage. Using a battery charger or AC adapter not exclusive to this camera, or using the exclusive battery charger or AC adapter with an unspecified power or voltage can cause a fire, electric shock, or camera breakdown. The specified voltage is 100 - 240V AC.
- Do not disassemble or modify the product. This can cause a fire or electrical shock.
- If the generation of smoke or strange odor from the product or other abnormality occurs, immediately discontinue using and consult your nearest service center. Continued use can cause a fire or electrical shock.
- If water should happen to get inside the product, consult your nearest service center. Continued use can cause a fire or electrical shock.
- If you see a lightning flash or hear thunder during use of the battery charger or AC adapter, unplug the power plug and discontinue use. Continued use can cause damage to the product, fire or electrical shock.
- Wipe off the power plug if it should become covered with dust. Accumulated dust may cause a fire.
- To reduce the risk of hazards, use only CSA/UL certified power supply cord set, cord is Type SPT-2 or heavier, minimum NO.18 AWG copper, one end with a molded-on male attachment plug cap (with a specified NEMA configuration), and the other is provided with a molded-on female connector body (with a specified IEC nonindustrial type configuration) or the equivalent.



Caution

- Do not place or drop heavy objects on or forcefully bend the AC plug cord. Doing so may damage the cord. Should the AC plug cord be damaged, consult your nearest service center.

- Do not touch or short-circuit the terminal area of the AC plug cord while the cord is plugged in.
- Do not handle the power plug with wet hands. This can cause an electric shock.
- Do not drop the product, or subject it to violent impact. This can cause the product to breakdown.
- Do not use the battery charger D-BC68P to charge batteries other than the rechargeable lithium-ion battery D-LI68. Attempting to charge other types of batteries may cause an explosion or heating, or may damage the battery charger.

About the Rechargeable Lithium-ion Battery

Warning

- If any leakage from the battery should come in contact with your eyes, do not rub them. Flush your eyes with clean water and get medical attention immediately.

Caution

- Only use the specified battery with this camera. Use of other batteries may cause an explosion or fire.
- Do not disassemble the battery. Disassembling the battery may cause an explosion or leakage.
- Remove the battery from the camera immediately if it becomes hot or begins to smoke. Be careful not to burn yourself during removal.
- Keep wires, hairpins, and other metal objects away from the + and - contacts of the battery.
- Do not short the battery or dispose of the battery in fire. This can cause an explosion or fire.
- If any leakage from the battery should come in contact with skin or clothing, it may cause irritation to the skin. Wash the affected areas thoroughly with water.
- Precautions for D-LI68 Battery Usage:
 - USE SPECIFIED CHARGER ONLY.
 - DO NOT INCINERATE.
 - DO NOT DISASSEMBLE.
 - DO NOT SHORT CIRCUIT.
 - DO NOT EXPOSE TO HIGH TEMP. (140°F / 60°C)

Keep the Camera and its Accessories out of the Reach of Small Children

Warning

- Do not place the camera and its accessories within the reach of small children.
 1. If the product falls or is operated accidentally, it may cause serious personal injuries.
 2. Wrapping the strap around a neck may cause suffocation.
 3. To avoid the risk of a small accessory such as the battery or SD Memory Cards from being swallowed by mistake, keep them out of the reach of small children. Seek medical attention immediately if an accessory is accidentally swallowed.

Care to be Taken During Handling

Before Using Your Camera

- When traveling, take the Worldwide Service Network listing that is included in the package. This will be useful if you experience problems abroad.
- When the camera has not been used for a long time, confirm that it is still working properly, particularly prior to taking important pictures (such as at a wedding or when traveling). Contents of the recording cannot be guaranteed if recording, playback or transferring your data to a computer, etc. is not possible due to a malfunction of your camera or recording media (SD Memory Card), etc.

About the Battery and Charger

- To keep the battery in optimum condition, avoid storing it in a fully charged state or in high temperatures.
- If the battery is left inserted and the camera is not used for a long time, the battery will over-discharge and shorten the battery's life.
- Charging the battery a day before use or on the day of use is recommended.
- The AC plug cord provided with this camera is developed exclusively for the battery charger D-BC68P. Do not use it with other devices.

Precautions on Carrying and Using Your Camera

- Do not subject the camera to high temperatures or high humidity. Do not leave the camera in a vehicle, as the temperature can get very high.
- Do not subject the camera to strong vibrations, shocks, or pressure. Use a cushion to protect the camera from vibrations of motorcycles, automobiles, or ships.
- The temperature range for camera use is 0°C to 40°C (32°F to 104°F).
- The monitor may appear black at high temperatures, but will return to normal at normal temperatures.
- The monitor may respond more slowly at low temperatures. This is due to liquid crystal properties, and is not a malfunction.
- Sudden temperature changes will cause condensation on the inside and outside of the camera. Place the camera in your bag or a plastic bag, and remove it after temperatures of the camera and surroundings are equalized.
- Avoid contact with garbage, mud, sand, dust, water, toxic gases, or salt. These could cause the camera to breakdown. Wipe the camera to dry off any rain or water drops.
- Do not press the monitor with excessive force. This could cause it to break or malfunction.
- Be careful not to overtighten the screw in the tripod socket when using a tripod.

Cleaning Your Camera

- Do not clean the camera with organic solvents such as thinner, alcohol, and benzene.
- Use a lens brush to remove dust accumulated on the lens. Never use a spray blower for cleaning as it may damage the lens.
- Please contact your nearest service center for professional cleaning of the CMOS sensor. (This will involve a fee.)
- Periodic inspections are recommended every one to two years to maintain high performance.

Storing Your Camera

- Do not store the camera with preservatives or chemicals. Storage in high temperatures and high humidity can cause mold to grow on the camera. Remove the camera from its case and store it in a dry and well-ventilated place.
- Avoid using or storing the camera where it may be exposed to static electricity or electrical interference.
- Avoid using or storing the camera in direct sunlight or in locations where it may be exposed to rapid changes in temperature or to condensation.

About SD Memory Cards

- The SD Memory Card is equipped with a write-protect switch. Setting the switch to LOCK prevents new data from being recorded on the card, the stored data from being deleted, and the card from being formatted by the camera or computer.
- The SD Memory Card may be hot when removing the card immediately after using the camera.
- Do not remove the SD Memory Card or turn off the power while the card is being accessed. This may cause the data to be lost or the card to be damaged.
- Do not bend the SD Memory Card or subject it to violent impact. Keep it away from water and store away from high temperatures.
- Do not remove the SD Memory Card while formatting. The card may be damaged and become unusable.
- Data on the SD Memory Card may be deleted in the following circumstances. We do not accept any liability for data that is deleted if
 1. the SD Memory Card is mishandled by the user.
 2. the SD Memory Card is exposed to static electricity or electrical interference.
 3. the SD Memory Card has not been used for a long time.
 4. the SD Memory Card or the battery is removed while the card is being accessed.
- If the SD Memory Card is not used for a long time, the data on the card may become unreadable. Be sure to regularly make a backup of important data on a computer.

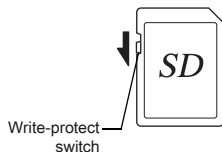

- Format new SD Memory Cards. Also format SD Memory Cards previously used with other cameras.
- Please note that deleting data stored on an SD Memory Card, or formatting an SD Memory Card does not completely erase the original data. Deleted files can sometimes be recovered using commercially available software. If you are going to discard, give away or sell your SD Memory Card, you should ensure that the data on the card is completely deleted or the card itself is destroyed if it contains any personal or sensitive information.
- The data on your SD Memory Card should be managed at your own risk.

About Eye-Fi Cards

- An SD Memory Card with a built-in wireless LAN ("Eye-Fi card") can be used with this camera.
- Use of an access point and an Internet connection are required for transferring images via wireless LAN. For details, refer to the Eye-Fi website. (<http://www.eye.fi>)
- Use Eye-Fi cards which have been updated to the newest firmware.
- Set [Eye-Fi] to [Off], or do not use an Eye-Fi card in a location where the use of wireless LAN devices is restricted or prohibited, such as airplanes.
- Eye-Fi cards can be used only in the country in which the card was purchased. Please observe all local laws governing Eye-Fi card usage.
- This camera features a function to enable/disable the communication function of the Eye-Fi card, however, we do not guarantee the operability of all Eye-Fi card functions.
- Refer to the Eye-Fi card manual for details on how to use the card.
- Please contact the Eye-Fi card manufacturer regarding any malfunctions or problems concerning Eye-Fi cards.

Trademarks

Windows and Windows Vista are registered trademarks of Microsoft Corporation in the United States of America and other countries. Macintosh, Mac OS, and QuickTime are trademarks of Apple Inc., registered in the U.S. and other countries.

Intel, Intel Core, and Pentium are trademarks of Intel Corporation in the U.S. and/or other countries.

SDXC Logo is a trademark of SD-3C, LLC.

Eye-Fi, the Eye-Fi logo and Eye-Fi *connected* are trademarks of Eye-Fi, Inc.

This product includes DNG technology under license by Adobe Systems Incorporated.

The DNG logo is either a registered trademark or trademark of Adobe Systems Incorporated in the United States and/or other countries.

HDMI, the HDMI logo and High-Definition Multimedia Interface are trademarks or registered trademarks of HDMI Licensing, LLC in the United States and/or other countries.

All other trademarks are the property of their respective owners.

This product supports PRINT Image Matching III. PRINT Image Matching enabled digital still cameras, printers and software help photographers to produce images more faithful to their intentions. Some functions are not available on printers that are not PRINT Image Matching III compliant. Copyright 2001 Seiko Epson Corporation. All Rights Reserved. PRINT Image Matching is a trademark of Seiko Epson Corporation. The PRINT Image Matching logo is a trademark of Seiko Epson Corporation.



AVC Patent Portfolio License

This product is licensed under the AVC Patent Portfolio License for the personal use of a consumer or other uses in which it does not receive remuneration to (i) encode video in compliance with the AVC standard ("AVC video") and/or (ii) decode AVC video that was encoded by a consumer engaged in a personal activity and/or was obtained from a video provider licensed to provide AVC video. No license is granted or shall be implied for any other use.

Additional information may be obtained from MPEG LA, L.L.C. See <http://www.mpegla.com>.

WARRANTY POLICY

All our cameras purchased through authorized bona fide photographic distribution channels are guaranteed against defects of material or workmanship for a period of twelve months from the date of your purchase. Service will be rendered, and defective parts will be replaced without cost to you within that period, provided the camera does not show evidence of impact, sand or liquid damage, mishandling, tampering, battery or chemical corrosion, operation contrary to operating instructions, or modification by an unauthorized repair shop. The manufacturer or its authorized representatives shall not be liable for any repair or alterations except those made with its written consent and shall not be liable for damages from delay or loss of use or from other indirect or consequential damages of any kind, whether caused by defective material or workmanship or otherwise; and it is expressly agreed that the liability of the manufacturer or its representatives under all guarantees or warranties, whether expressed or implied, is strictly limited to the replacement of parts as hereinbefore provided. No refunds will be made on repairs by non-authorized service facilities.

Procedure During 12-month Warranty Period

Any camera which proves defective during the 12-month warranty period should be returned to the dealer from whom you purchased the camera or to the manufacturer. If there are no representatives of the manufacturer in your country, send the camera to the manufacturer, with postage prepaid. In this case, it will take a considerable length of time before the camera can be returned to you owing to the complicated customs procedures required. If the camera is covered by warranty, repairs will be made and parts replaced free of charge,

and the camera will be returned to you upon completion of servicing. If the camera is not covered by warranty, regular charges of the manufacturer or of its representatives will apply. Shipping charges are to be borne by the owner. If your camera was purchased outside of the country where you wish to have it serviced during the warranty period, regular handling and servicing fees may be charged by the manufacturer's representatives in that country. Notwithstanding this, your camera returned to the manufacturer will be serviced free of charge according to this procedure and warranty policy. In any case, however, shipping charges and customs clearance fees to be borne by the sender. To prove the date of your purchase when required, please keep the receipt or bills covering the purchase of your camera for at least a year. Before sending your camera for servicing, please make sure that you are sending it to the manufacturer's authorized representatives or their approved repair shops, unless you are sending it directly to the manufacturer. Always obtain a quotation for the service charge, and only after you accept the quoted service charge, instruct the service station to proceed with the servicing.

- **This warranty policy does not affect the customer's statutory rights.**
- **The local warranty policies available from our distributors in some countries can supersede this warranty policy. Therefore, we recommend that you review the warranty card supplied with your product at the time of purchase, or contact our distributor in your country for more information and to receive a copy of the warranty policy.**



The CE Mark is a Directive conformity mark of the European Union.

For customers in USA

STATEMENT OF FCC COMPLIANCE

This device complies with Part 15 of the FCC Rules. Operation is subject to the following two conditions: (1) This device may not cause harmful interference, and (2) this device must accept any interference received, including interference that may cause undesired operation.

Changes or modifications not approved by the party responsible for compliance could void the user's authority to operate the equipment.

This equipment has been tested and found to comply with the limits for a Class B digital device, pursuant to part 15 of the FCC Rules.

These limits are designed to provide reasonable protection against harmful interference in a residential installation.

This equipment generates, uses and can radiate radio frequency energy and, if not installed and used in accordance with the instructions, may cause harmful interference to radio communications. However, there is no guarantee that interference will not occur in a particular installation.

If this equipment does cause harmful interference to radio or television reception, which can be determined by turning the equipment off and on, the user is encouraged to try to correct the interference by one or more of the following measures:

- Reorient or relocate the receiving antenna.
 - Increase the separation between the equipment and receiver.
 - Connect the equipment into an outlet on a circuit different from that to which the receiver is connected.
- * Consult the dealer or an experienced radio/TV technician for help.

For customers in Canada

This Class B digital apparatus complies with Canadian ICES-003.

Pour les utilisateurs au Canada

Cet appareil numérique de la classe B est conforme à la norme NMB-003 du Canada.

FOR CALIFORNIA, U.S.A. ONLY

Perchlorate Material-special handling may apply.

The lithium battery used in this camera contains perchlorate material, which may require special handling.

See www.dtsc.ca.gov/hazardouswaste/perchlorate

Declaration of Conformity According to 47CFR, Parts 2 and 15 for Class B Personal Computers and Peripherals

We: PENTAX RICOH IMAGING
AMERICAS CORPORATION

Located at: 633 17th Street, Suite 2600
Denver, Colorado 80202 U.S.A.
Phone: 800-877-0155
FAX: 303-790-1131

Declare under sole responsibility that the product identified herein complies with 47CFR Parts 2 and 15 of the FCC rules as a Class B digital device. Each product marketed is identical to the representative unit tested and found to be compliant with the standards. Records maintained continue to reflect the equipment being produced can be expected to be within the variation accepted, due to quantity production and testing on the statistical basis as required by 47CFR §2.909. Operation is subject to the following two conditions: (1) This device may not cause harmful interference, and (2) This device must accept any interference received, including interference that may cause undesired operation. The above named party is responsible for ensuring that the equipment complies with the standards of 47CFR §15.101 to §15.109.

Product Name: Digital Camera
Model Number: PENTAX Q7
Contact person: Customer Service Manager
Date and Place: June, 2013, Colorado

Information for Users on Collection and Disposal of Old Equipment and Used Batteries



1. In the European Union

These symbols on the products, packaging and/or accompanying documents mean that used electrical and electronic equipment and batteries should not be mixed with general household waste.

Used electrical/electronic equipment and batteries must be treated separately and in accordance with legislation that requires proper treatment, recovery and recycling of these products.



By disposing of these products correctly you will help ensure that the waste undergoes the necessary treatment, recovery and recycling and thus prevent potential negative effects on the environment and human health which could otherwise arise due to inappropriate waste handling.

If a chemical symbol is added beneath the symbol shown above, in accordance with the Battery Directive, this indicates that a heavy metal (Hg = Mercury, Cd = Cadmium, Pb = Lead) is present in the battery at a concentration above an applicable threshold specified in the Battery Directive.

For more information about collection and recycling of used products, please contact your local authorities, your waste disposal service or the point of sale where you purchased the products.

2. In other countries outside the EU

These symbols are only valid in the European Union. If you wish to discard used products, please contact your local authorities or dealer and ask for the correct method of disposal.

For Switzerland: Used electrical/electronic equipment can be returned free of charge to the dealer, even when you don't purchase a new product. Further collection facilities are listed on the home page of www.swico.ch or www.sens.ch.

RICOH IMAGING COMPANY, LTD.	2-35-7, Maeno-cho, Itabashi-ku, Tokyo 174-8639, JAPAN (http://www.ricoh-imaging.co.jp)
RICOH IMAGING EUROPE S.A.S.	112 Quai de Bezons, B.P. 204, 95106 Argenteuil Cedex, FRANCE (http://www.ricoh-imaging.fr)
RICOH IMAGING DEUTSCHLAND GmbH	Am Kaiserkai 1, 20457 Hamburg, GERMANY (http://www.ricoh-imaging.de)
RICOH IMAGING UK LTD.	PENTAX House, Heron Drive, Langley, Slough, Berks SL3 8PN, U.K. (http://www.ricoh-imaging.co.uk)
RICOH IMAGING AMERICAS CORPORATION	633 17th Street, Suite 2600, Denver, Colorado 80202, U.S.A. (http://www.ricoh-imaging.com)
RICOH IMAGING CANADA INC.	1770 Argentia Road Mississauga, Ontario L5N 3S7, CANADA (http://www.ricoh-imaging.ca)
RICOH IMAGING CHINA CO., LTD.	23D, Jun Yao International Plaza, 789 Zhaojiabang Road, Xu Hui District, Shanghai, 200032, CHINA (http://www.ricoh-imaging.com.cn)

- Specifications and external dimensions are subject to change without notice.