

# Always there to help you

Register your product and get support at  
[www.philips.com/welcome](http://www.philips.com/welcome)



CEM3100



## User manual

# PHILIPS



# Contents

---

<b>1 Important</b>	2
Safety	2
Notice	2

---

<b>2 Your car audio system</b>	4
Introduction	4
What's in the box	4
Overview of the main unit	5
Overview of the remote control	6

---

<b>3 Get started</b>	7
Install the car audio	7
Install remote control battery	10
Turn on	10
Set clock	10

---

<b>4 Listen to radio</b>	11
Tune to a radio station	11
Store radio stations in memory	11
Tune to a preset station	11
Play with RDS	12

---

<b>5 Play audio files</b>	14
Play a disc	14
Play from USB	14
Play from iPod/iPhone	14
Play options	16
Connect external sound source	16

---

<b>6 Adjust sound</b>	17
Adjust volume	17
Mute	17
Turn Dynamic Bass Boost (DBB) on/off	17
Turn on/off MAX sound	17
Select preset equalizer	17
Switch music listening zone	17
Turn on/off full sound	17
Other sound settings	18

---

<b>7 Adjust system settings</b>	18
Turn beep sound on/off	18
Select blackout setting	18
Turn demo mode on/off	18
Dimmer	19
Dance	19
Rear Aux	19
LCD Color	19
Audiobook	19
Reset	20

---

<b>8 Additional information</b>	20
Detach the front panel	20
Replace fuse	20
Remove the unit	21

---

<b>9 Product information</b>	21
------------------------------	----

---

<b>10 Troubleshooting</b>	22
---------------------------	----

# 1 Important

---

## Safety

- Read and understand all instructions before you use your apparatus. If damage is caused by failure to follow instructions, the warranty does not apply.
- This apparatus is designed for negative ground (earth) 12V DC operation only.
- To ensure safe driving, adjust the volume to a safe and comfortable level.
- Improper fuses can cause damage or fire. When you need to change the fuse, consult a professional.
- Use only the supplied mounting hardware for a safe and secure installation.
- To avoid short circuit, do not expose the apparatus, remote control or remote control batteries to rain or water.
- Never insert objects into the ventilation slots or other openings on the apparatus.
- Clean the apparatus and frame with a soft, damp cloth. Never use substances such as alcohol, chemicals or household cleaners on the apparatus.
- Never place any objects other than discs into the apparatus.
- Never use solvents such as benzene, thinner, cleaners available commercially, or anti-static sprays intended for discs.
- Visible and invisible laser radiation when open. Avoid exposure to beam.
- Risk of damage to the apparatus screen! Never touch, push, rub or strike the screen with any object.



### Caution

- Use of controls or adjustments or performance of procedures other than herein may result in hazardous radiation exposure or other unsafe operation.

- The apparatus shall not be exposed to dripping or splashing.
- Do not place any sources of danger on the apparatus (e.g. liquid filled objects, lighted candles).

---

## Notice

Any changes or modifications made to this device that are not expressly approved by WOOX Innovations may void the user's authority to operate the equipment.

---

## Recycling



Your product is designed and manufactured with high quality materials and components, which can be recycled and reused. When you see the crossed-out wheel bin symbol attached to a product, it means the product is covered by the European Directive 2002/96/EC:



Never dispose of your product with other household waste. Please inform yourself about the local rules on the separate collection of electrical and electronic products. The correct disposal of your old product helps prevent potentially negative consequences on the environment and human health.

Your product contains batteries covered by the European Directive 2006/66/EC, which cannot be disposed of with normal household waste. Please inform yourself about the local rules on separate collection of batteries. The correct disposal of batteries helps prevent potentially negative consequences on the environment and human health.

## Environmental information

All unnecessary packaging has been omitted. We have tried to make the packaging easy to separate into three materials: cardboard (box), polystyrene foam (buffer) and polyethylene (bags, protective foam sheet.)

Your system consists of materials which can be recycled and reused if disassembled by a specialized company. Please observe the local regulations regarding the disposal of packaging materials, exhausted batteries and old equipment.



The making of unauthorized copies of copy-protected material, including computer programs, files, broadcasts and sound recordings, may be an infringement of copyrights and constitute a criminal offence. This equipment should not be used for such purposes.



Windows Media and the Windows logo are trademarks, or registered trademarks of Microsoft Corporation in the United States and/or other countries.



"Made for iPod" and "Made for iPhone" mean that an electronic accessory has been designed to connect specifically to iPod, or iPhone respectively, and has been certified by the developer to meet Apple performance standards. Apple is not responsible for the operation of this device or its compliance with safety and regulatory standards. Please note that the use of this accessory with iPod, or iPhone may affect wireless performance.

Apple is not responsible for the operation of this device or its compliance with safety and regulatory standards.

iPod and iPhone are trademarks of Apple Inc., registered in the U.S. and other countries.

**This apparatus includes this label:**



2014 © WOOX Innovations Limited. All rights reserved.

Specifications are subject to change without notice. WOOX reserves the right to change products at any time without being obliged to adjust earlier supplies accordingly.

# 2 Your car audio system

Congratulations on your purchase, and welcome to Philips! To fully benefit from the support that Philips offers, register your product at [www.philips.com/welcome](http://www.philips.com/welcome).

## Introduction

With the in-car audio system, you can enjoy your drive while listening to:

- FM or AM (MW) radio
- Audio from CD or MP3 disc
- Audio from USB devices
- Audio from iPod/iPhone
- Audio from other external devices

The unit supports the following media format:



## What's in the box

Check and identify the contents of your package:

- ① Main unit (with a sleeve)
- ② Remote control
- ③ Front panel
- ④ Trim plate
- ⑤ Carrying case for front panel
- ⑥ Rubber cushion
- ⑦ Screw x 1 pc
- ⑧ Disassembly tools x 2 pcs
- ⑨ User manual
- ⑩ Quick start guide

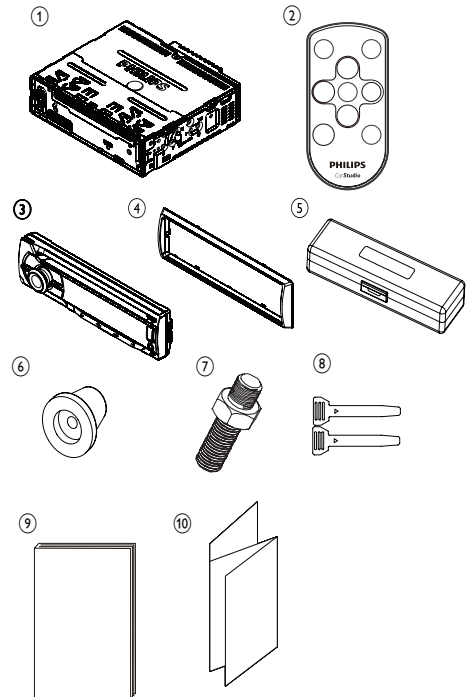



## Overview of the remote control

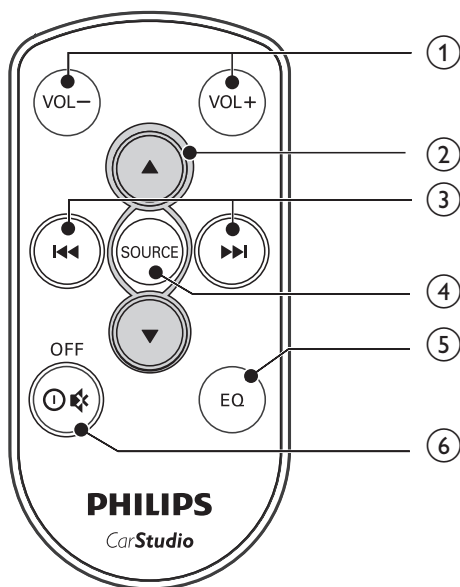

- ① **VOL +/-**
  - Adjust volume.
- ② **▲ / ▼**
  - Select tuner band.
  - Scroll up/down menu.
  - Select MP3/WMA folder.
- ③ **◀◀ / ▶▶**
  - Tune to a radio station
  - Skip track.
  - Fast backward/forward playback
- ④ **SOURCE**
  - Select audio source.
- ⑤ **EQ**
  - Select equalizer (EQ) settings.
- ⑥ **OFF / Ⓛ / 🔊**
  - Turn the unit on or off.
  - Mute or restore volume.

- ⑥ **▲**
  - Eject disc.
- ⑦ **◀◀**
  - USB socket.
- ⑧ **MP3 LINK**
  - Connect external audio device.
- ⑨ **MAX SOUND**
  - Turn on or off Maximizing volume.
  - View clock.
- ⑩ **DBB**
  - Turn on or off Dynamic Bass Boost (DBB) sound.
  - Access to tuner auto store.
- ⑪ **▶▶**
  - Select preset radio station No.6.
  - Start play.
  - Pause or resume play.
- ⑫ **REP / SHUF**
  - Access to repeat play.
  - Access to shuffle play.
  - Select preset radio station No.3/4.
- ⑬ **♪ / 📁**
  - Select preset radio station No.1/2.
  - Search for track/folder.
- ⑭ **◀◀ / ▶▶**
  - Tune for radio station.
  - Skip/search for track.
  - Fast backward/forward playback.
- ⑮ **DISP**
  - Display current status.
  - Turn the dimmer on and off.
- ⑯ **EQ / AUDIO**
  - Select equalizer (EQ) setting.
  - Access audio setting menu.
- ⑰ **🔒**
  - Unlock the panel.
- ⑱ **BAND**
  - Select tuner band.
- ⑲ **RESET**
  - Restore default settings.
- ⑳ **Disc slot**

# 3 Get started

## ! Caution

- Use the controls only as stated in this user manual.

Always follow the instructions in this chapter in sequence.

If you contact the Consumer Care, you will be asked for the model and serial number of this apparatus. The model number and serial number are on the bottom of your apparatus. Write the numbers here:

Model No. \_\_\_\_\_

Serial No. \_\_\_\_\_

## Install the car audio

These instructions are for a typical installation. However, if your car has different requirements, make the corresponding adjustment. If you have any question regarding installation kits, consult your local retailer.

## ! Caution

- This unit is designed for negative ground (earth) 12V DC operation only.
- Always install this unit in the car dashboard. Other locations can be dangerous as the rear of the unit heats up during use.
- To avoid short-circuit: before you connect, ensure that the ignition is off.
- Ensure that you connect the yellow and red power supply leads after all other leads are connected.
- Ensure that all loose leads are insulated with electrical tape.
- Ensure that the leads do not get caught under screws or in parts that will move (e.g. seat rail).
- Ensure that all ground (earth) leads are run to a common ground (earth) point.
- Use only the supplied mounting hardware for a safe and secure installation.
- Improper fuses can cause damage or fire. When you need to change the fuse, consult a professional.

## Note on the power supply lead (yellow)

- When you connect other devices to this apparatus, ensure that the rating of the car circuit is higher than the total fuse value of all the connected devices.

## Notes on speaker connection

- Never connect speaker wires to the metal body or chassis of the car.
- Never connect speaker wires with stripes to one another.

## Connection: for cars with ISO connectors

## ! Caution

- Ensure that all loose leads are insulated with electrical tape.

## ≡ Note

- Consult a professional to connect CEM3100 as instructed below.
- The ISO male connectors are not supplied.

1 Connect the male connector to the unit.

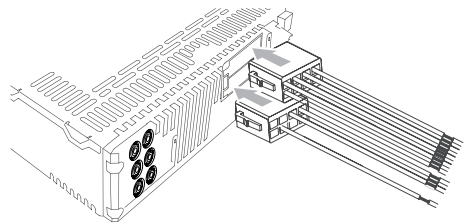

2 Check the car's wiring carefully and connect them to the the male connector.

## ≡ Note

- Risk of danger! Please consult a professional to perform the below steps!

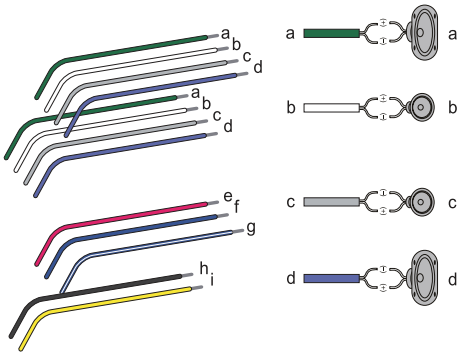

1	Green/black strip	Left speaker (Rear)
2	White/black strip	Left speaker (Front)
3	Gray/black strip	Right speaker (Front)
4	Purple/black strip	Right speaker (Rear)
e	Red	Ignition key +12V DC when ON/ACC
f	Blue	Motor/electric antenna relay control lead
g	White-edged blue strip	Amplifier relay control lead
h	Black	Ground
i	Yellow	To the +12V car battery which is energized at all times

- 3** Connect the antenna and amplifier as illustrated, if applicable.

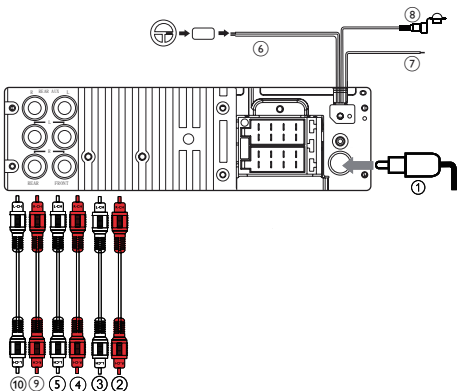

Connector	Connect to
1 ANTENNA	Antenna
2 FRONT LINE OUT R (Socket)	Front right speaker
3 FRONT LINE OUT L (Socket)	Front left speaker
4 REAR LINE OUT R (Socket)	Rear right speaker
5 REAR LINE OUT L (Socket)	Rear left speaker
6 OE REMOTE (Purple)	OE Remote
7 TEL MUTING (Blue)	To cellular phone system
8 SUBWOOFER (Blue)	Subwoofer
9 REAR AUX LINE OUT R	Rear Aux right
10 REAR AUX LINE OUT L	Rear Aux left

#### Tip

- The pin arrangement for the ISO connectors depends on the type of vehicle you drive. Be sure to make proper connections to prevent damage to the unit.

## Mount into the dashboard

- If the car does not have an on-board drive or navigation computer, disconnect the negative terminal of the car battery.
  - If you disconnect the car battery in a car that has an on-board drive or navigation computer, the computer may lose its memory.
  - If the car battery is not disconnected, to avoid short-circuit, ensure that the bare wires do not touch each other.

- 2 Ensure that car dashboard opening is within these measurements:

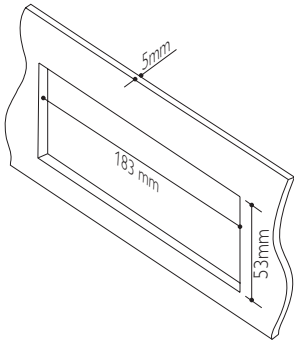

- 3 Remove the mounting sleeve with the supplied disassembly tools.

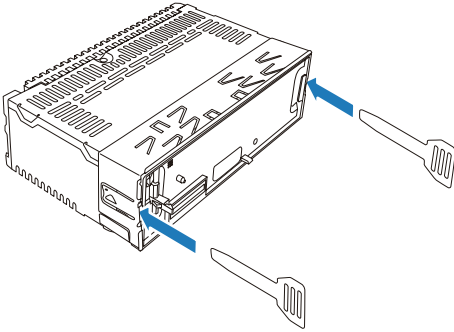

- 4 Install the sleeve into the dashboard and bend the tabs outward to fix the sleeve.

**Note**

- If the unit is not fixed by sleeve but by the supplied screws, skip this step.

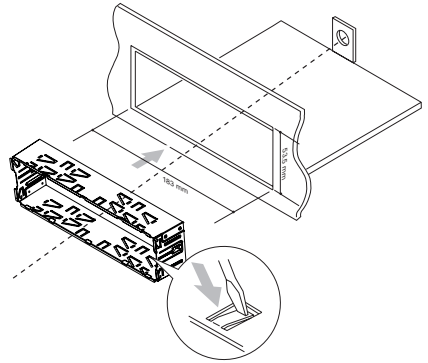

- 5 Place the supplied rubber cushion over the end of the mounting bolt.

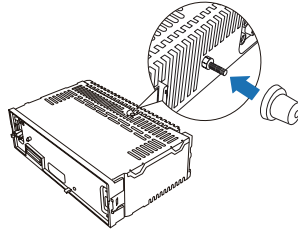

- 6 Slide the unit into the dashboard until you hear a click sound.

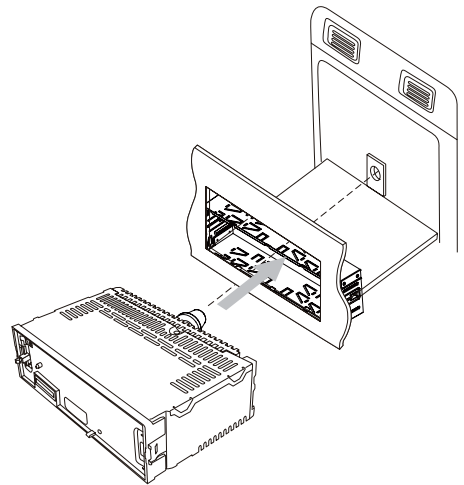

- 7 Reconnect the negative terminal of the car battery.

---

## Attach the front panel

- 1 Attach the trim plate.
- 2 Insert the right side of the panel in the chassis until it is correctly engaged.
- 3 Press the left side of the panel until the mechanism locks it into place.

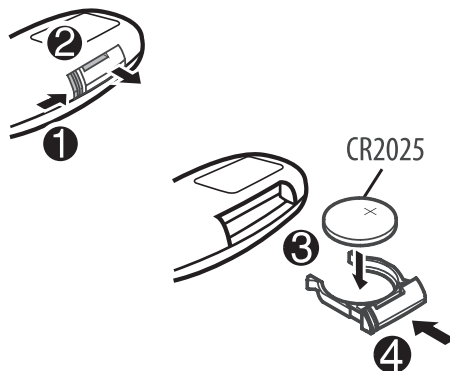
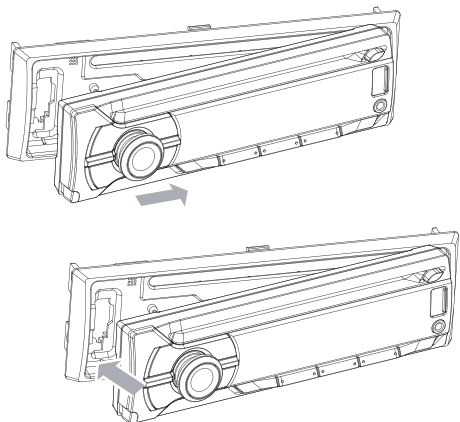

---

## Turn on

To turn on the unit,

- Press  $\odot$ .

To turn off the unit,

- press and hold  $\odot$  until the unit is turned off.

---

## Install remote control battery

### ! Caution

- Risk of explosion! Keep batteries away from heat, sunshine or fire. Never discard batteries in fire.
- Risk of decreased battery life! Never mix different brands or types of batteries.
- Risk of product damage! When the remote control is not used for long periods, remove the batteries.
- Perchlorate Material - special handling may apply. See [www.dtsc.ca.gov/hazardouswaste/perchlorate](http://www.dtsc.ca.gov/hazardouswaste/perchlorate).

### For first-time use:

Remove the protective tab to activate the remote control battery.

### To replace the remote control battery:

- 1 Open the battery compartment.
- 2 Insert one CR2025 battery with correct polarity (+/-) as indicated.
- 3 Close the battery compartment.

---

## Set clock

- 1 Press **MENU** repeatedly until current time is flashed.
- 2 Rotate  $\odot$  to set hour.
- 3 Press  $\odot$  to confirm.
- 4 Rotate  $\odot$  to set minute.
- 5 Press  $\odot$  to confirm.

---

## Set clock format

- 1 Press **MENU**.
- 2 Press  $\blacktriangle$  or  $\blacktriangledown$  repeatedly until **[CLOCK FORMAT]** is displayed.
- 3 Rotate  $\odot$  to select a setting:
  - **[CLOCK 12H]**
  - **[CLOCK 24H]**

---

## View clock

In any mode, press and hold **MAX SOUND** until the clock is displayed.

- Press any key to cancel the clock display.

# 4 Listen to radio

---

## Tune to a radio station

- 1 Press **SOURCE** repeatedly to select radio mode.
- 2 Press **BAND** or ▲ / ▼ repeatedly to select band: **[FM1]**, **[FM2]**, **[FM3]**, **[AM1]**, or **[AM2]**.
- 3 Press and hold **◀◀** or **▶▶** until the frequency digit is flashed.
- 4 Press **◀◀** or **▶▶** to tune to a radio station manually.
  - ↳ The radio station is broadcast.
  - To search for a radio station automatically, press **◀◀** or **▶▶**.

---

## Select tuner region

You can select suitable country/region of the radio.

- 1 Press **SOURCE** to select radio mode.
- 2 Press **MENU** repeatedly until **[AREA]** is displayed..
- 3 Rotate **⊙** to select:
  - **[USA]** (United States)
  - **[LATIN]** (Latin America)
  - **[EUROPE]** (Western Europe)
  - **[M-EAST]** (Middle East)
  - **[ASIA]** (Asia Pacific)
  - **[JAP]** (Japan)
  - **[AUST]** (Australia)
- 4 Press **⊙** to confirm.

---

## Select tuner sensitivity

To receive more radio stations or only stations with strong signal, you can adjust the tuner sensitivity.

- 1 Press **MENU** repeatedly until **[LOCAL]** is displayed.
- 2 Rotate **⊙** to select a setting:
  - **[LOCAL ON]** (local on): Only stations with strong signal can be broadcast.
  - **[LOCAL OFF]** (local off): Stations with strong and weak signals can be broadcast.

---

## Store radio stations in memory

You can store up to 6 stations in each band.

---

## Store stations automatically

- 1 In Radio mode, press and hold **DBB** until **[STORE - - -]** is displayed.
- 2 Press **⊙** to confirm.
  - ↳ The six strongest stations of the selected band are saved in preset channel automatically.

---

## Store stations manually

- 1 Tune to a station that you want to store (see 'Tune to a radio station' on page 12).
- 2 Press a numeric button for 3 seconds.
  - ↳ The station is saved in the selected channel.

---

## Tune to a preset station

- 1 Press **BAND** to select band.
- 2 Press a numeric key to select a preset station.

---

## Play with RDS

The RDS (Radio Data System) function operates only in areas with FM stations broadcasting RDS signals. If you tune to an RDS station, the station name are displayed.

---

### Turn on RDS



Note

- The default setting for RDS is on.

- 1 Press **MENU**.
- 2 Press **▲** or **▼** repeatedly until **[RDS]** is displayed.
- 3 Rotate **⊙** to select **[RDS ON]**.  
↳ The RDS function is turned on.

---

### Select program type

Before tuning to RDS stations, you can select program type and let the unit search only for programs of the selected category.

- 1 Press **MENU**.
- 2 Press **▲** or **▼** repeatedly until **[PTY]** is displayed.
- 3 Press **⊙** to confirm.
- 4 Rotate **⊙** to select a type, then press **⊙** to confirm.

---

Item	Program type	Description
1	<b>NEWS</b>	News services
2	<b>AFFAIRS</b>	Politics and current affairs
3	<b>INFO</b>	Special information programs
4	<b>SPORT</b>	Sports
5	<b>EDUCATE</b>	Education and advanced training
6	<b>DRAMA</b>	Radio plays and literature

---

---

7	<b>CULTURE</b>	Culture, religion and society
8	<b>SCIENCE</b>	Science
9	<b>VARIED</b>	Entertainment programs
10	<b>POP M</b>	Pop music
11	<b>ROCK M</b>	Rock music
12	<b>EASY M</b>	Light music
13	<b>LIGHT M</b>	Light classical music
14	<b>CLASSICS</b>	Classical music
15	<b>OTHER M</b>	Special music programs
16	<b>WEATHER</b>	Weather
17	<b>FINANCE</b>	Finance
18	<b>CHILDREN</b>	Children's programs
19	<b>SOCIAL</b>	Social Affairs
20	<b>RELIGION</b>	Religion
21	<b>PHONE IN</b>	Phone In
22	<b>TRAVEL</b>	Travel
23	<b>LEISURE</b>	Leisure
24	<b>JAZZ</b>	Jazz Music
25	<b>COUNTRY</b>	Country Music
26	<b>NATION M</b>	National Music
27	<b>OLDIES</b>	Oldies Music
28	<b>FOLK M</b>	Folk Music
29	<b>DOCUMENT</b>	Documentary
30	<b>TEST</b>	Alarm Test
31	<b>ALARM</b>	Alarm

---

### Select alternate frequencies

If the radio signal is poor, turn on AF (Alternate Frequency) to search for another station with stronger signal.

- 1 Press **MENU**.
- 2 Press **▲** or **▼** repeatedly until **[AF]** is displayed.
- 3 Rotate **⊙** to select a setting:
  - **[AF ON]**: turn AF mode on.
  - **[AF OFF]**: turn AF mode off.

## Set region for AF tuning

You can define AF tuning region:

[REG ON]	Only stations in current region can be tuned to automatically.
[REG OFF]	All stations can be tuned to automatically.

- 1 Press **MENU**.
- 2 Press **▲** or **▼** repeatedly until **[REG]** is displayed.
- 3 Rotate **⊖** to select a setting.

## Receive traffic announcement

If you do not want to miss traffic announcement when enjoying music, turn on the TA (Traffic Announcement) function.

- 1 Press **MENU**.
- 2 Press **▲** or **▼** repeatedly until **[TA]** is displayed.
- 3 Rotate **⊖** to select a setting:
  - **[TA ON]**: when there is traffic announcement, the unit switches to the tuner mode (regardless of the current mode) and begins to broadcast the traffic conditions. When the traffic announcement is over, it returns to the previous mode.
  - **[TA OFF]**: traffic announcement does not cut in.



### Note

- If the current received TA signal remains weak for over 120 seconds, the unit will activate TA Seek mode automatically. The TA Seek will seek for other station with good condition of TA signal.



### Tip

- When a traffic announcement cuts in, user can short press **↵** to terminate the traffic announcement, and the unit will resume to previous playback mode.

## Set RDS clock

You can use time signal that is broadcast together with the RDS signal to set the clock of the unit automatically.

- 1 Press **MENU**.
- 2 Press **▲** or **▼** repeatedly until **[CT]** is displayed.
- 3 Rotate **⊖** to select a setting:
  - **[CT ON]**: turn on the RDS clock. Time shown on the unit synchronizes with that on the RDS station.
  - **[CT OFF]**: turn off the RDS clock.



### Tip

- The accuracy of the transmitted time depends on the RDS station that transmits the time signal.

# 5 Play audio files

## Note

- Ensure that the disc or device contains playable files.

## Play a disc

## Note

- You cannot play CDs encoded with copyright protection technologies.

You can play commercially available audio CDs and these discs:

- CD-Recordables (CD-R)
- CD-Re-writables (CD-RW)
- MP3 CDs
- WMA CDs

## Note

- Ensure that the disc contains playable content.

Insert a CD with the printed side facing up.

↳ Play starts automatically.

- To pause CD play, press **▶||**.
- To resume CD play, press **▶||** again.
- To skip to the previous/next track, press **◀◀** or **▶▶**.
- To search backward/forward rapidly within the current track, press **◀◀** or **▶▶** for 3 seconds.

## Remove the CD

To take out the CD, press **▲** on the front panel.

## Tip

- If the disc is blocked in the disc compartment, press and hold **▲** until the disc comes out.

## Play from USB

## Note

- Ensure that the USB device contains playable music.

## Insert the USB device

- 1 Slide the USB socket cover marked **↔** to the left.
- 2 Insert the USB device into the USB socket.  
↳ The unit starts playing from the USB device automatically.



## Remove the USB device

- 1 Press **⊖** to turn off the unit.
- 2 Remove the USB device.

## Play from iPod/iPhone

You can enjoy audio from iPod/iPhone through this unit.

## Compatible iPod/iPhone

Apple iPod and iPhone models with a 30-pin dock connector:

Made for:

- iPod nano (2nd generation)
- iPod nano (3rd generation 4GB)
- iPod nano (3rd generation 8GB)
- iPod nano (4th generation)
- iPod nano (5th generation)
- iPod nano (6th generation)
- iPod classic (1st generation)

- iPod classic (2nd generation)
- iPod touch (1st generation)
- iPod touch (2nd generation)
- iPod touch (3rd generation)
- iPod video (30GB & 80GB)

Works with:

- iPhone
- iPhone 3G
- iPhone 3GS
- iPhone 4
- iPhone 4S

---

## Connect iPod/iPhone

- 1 Slide the USB socket cover marked  to the left.
- 2 Insert USB adaptor on one end of iPod/iPhone cable to the USB socket on the main unit.
- 3 Insert the other end of the iPod/iPhone cable to the iPod/iPhone socket.
  - ↳ The unit starts playing from the iPod/iPhone automatically.

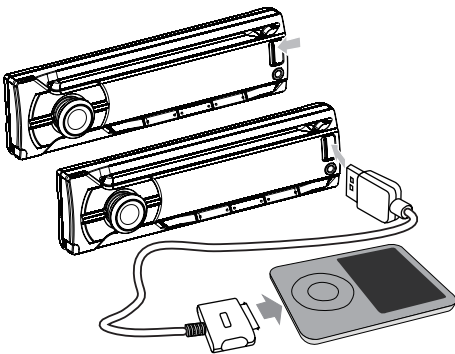









---

## Control music playback on iPod/iPhone

- 1 Ensure that the iPod/iPhone is connected correctly.
- 2 Press **SOURCE** to select iPod USB mode.







- 3 Press  repeatedly to toggle between the two control modes:
  - **iPod control mode:** Use the buttons/touch screen on iPod/iPhone to control the music.
  - **Audio control mode:** Use the control buttons on car audio to control the music.

### To control playback under audio control mode:

- To pause/resume play, press .
- To skip to a track, press  / .
- To search during play, press and hold  / , then release to resume normal play.
- To navigate the menu, press , rotate  to select, then press  to confirm.

---

## Search for a track

- 1 Press **SOURCE** repeatedly to select iPod mode.
- 2 Press  to browse iPod/iPhone menu.
- 3 Rotate  to select the Artist search mode, and press  to confirm.
- 4 Press **DISP** to search alphabetically.
- 5 Rotate  to select desired artist, then press  to confirm.
- 6 Rotate  to select desired song in current album.
- 7 Press  to start play.

### Note

- User cannot control the music via iPod/iPhone under audio control mode.

---

## Play options

---

### Search for an MP3/WMA track

#### Search within the current folder

- 1 Press **↵**.  
↳ The name of the current track is displayed.
- 2 Rotate **⊙** to select another track in current folder.
- 3 Press **⊙** to confirm.

#### Search in other folder

- 1 Press **⏪**.  
↳ The name of the current folder is displayed.
- 2 Rotate **⊙** to navigate through all folders.
- 3 Press **⊙** to access the selected folder.  
↳ The unit starts playing the first song from the selected folder automatically.



Tip

- To go back to upper level of a folder, press **⏪**.

---

### View play information

During playing, press **DISP** repeatedly to view:

- Track number and elapsed play time
- Folder
- File
- Album
- Artist
- Title

---

### Repeat play

- 1 During play, press **REP**.  
↳ **[REPEAT]** is displayed.

- 2 Rotate **⊙** to select a setting.
  - **[REPEAT TRK]** (repeat one track): play current track repeatedly.
  - **[REPEAT FLD]** (repeat a folder): play all tracks in the current folder repeatedly.
  - **[REPEAT ALL]** (repeat all tracks): play all tracks repeatedly.

---

### Shuffle play

You can play the tracks in random order:

- 1 During play, press **SHUF**.  
↳ **[SHUFFLE]** is displayed.
- 2 Rotate **⊙** to select a setting:
  - **[SHUFFLE FLD]**: start random play for all tracks in the current folder.
  - **[SHUFFLE ALL]**: start random play for all tracks.
  - **[SHUFFLE OFF]**: cancel shuffle play.

---

### Connect external sound source

- 1 Connect the external sound source to **MP3 LINK** socket with a 3.5 mm cable.
- 2 Press **SOURCE** repeatedly until **[MP3 LINK]** is displayed.
- 3 Operate the external component (refer to the instructions supplied with the external component).

# 6 Adjust sound

---

## Adjust volume

Turn  clockwise/counterclockwise to increase/decrease volume.

## Mute

You can turn off the sound of your audio. During play, press .

- To resume sound, press  again.

## Turn Dynamic Bass Boost (DBB) on/off

- 1 Press **DBB** and the current setting is displayed:
  - ↳ **[DBB ON]**: Dynamic Bass Boost (DBB) function is on.
  - ↳ **[DBB OFF]**: Dynamic Bass Boost (DBB) function is off.
- 2 Press **DBB** again to change the DBB setting.

## Turn on/off MAX sound

- 1 Press **MAX SOUND**.
  - ↳ The current setting displays
    - **[MAX ON]**: The maximum sound (MAX sound) function is on.
    - **[MAX OFF]**: The maximum sound function is off.
- 2 Press **MAX SOUND** again to select an option.

---

## Select preset equalizer

- 1 Press **EQ / AUDIO**.
  - ↳ Current Equalizer setting is displayed.
- 2 Press **EQ / AUDIO** again to select a preset EQ setting:
  - **[OPTIMAL]** (optimal)
  - **[FLAT]** (flat)
  - **[POP]** (pop)
  - **[USER]** (user)
  - **[TECHNO]** (techno)
  - **[ROCK]** (rock)
  - **[CLASSIC]** (classic)
  - **[JAZZ]** (jazz)

---



## Switch music listening zone

Philips' innovative Zone technology enables driver or passengers to enjoy music with the best speakers balance and experience more vivid spacial effect as the artist is intended to create. You can switch the music listening zone from driver to passengers for the best speaker sound settings in car.

- 1 Press and hold **ZONE**.
  - ↳ The current setting is displayed.
- 2 Press **▲ / ▼** to select a setting:
  - **[ALL]**
  - **[FRONT LEFT]** (Front left)
  - **[FRONT RIGHT]** (Front right)
  - **[FRONT]**

---

## Turn on/off full sound

- 1 Press and hold .
  - ↳ The current setting displays:
    - **[FULL ON]** :The full sound function is on.
    - **[FULL OFF]** :The full sound function is off.
- 2 Press  again to select an option.

---

## Other sound settings

You can also adjust the preset **EQ / AUDIO** settings.

- 1 Press **EQ / AUDIO** for 3 seconds.
- 2 Press **▲** or **▼** repeatedly to select the item to be adjusted:
  - **[SUBWOOFER ON/OFF]** : Rotate **⊙** to turn on or off the subwoofer.
  - **[SUBWOOFER]** range: 0 to 12.
  - **[SUBWOOFER LPF]** (Subwoofer low pass filter) range: 80, 120, 160.
  - **[BALANCE]** range: 12L to 12R. (L=left speaker, R=right speaker)
  - **[FADER]** range: 12R to 12F. (R=rear speaker, F=front speaker)
  - **[BASS]** range: -7 to +7.
  - **[BASS CFQ]** (bass center frequency) range: 60, 80, 100, 200.
  - **[MIDDLE]** range: -7 to +7.
  - **[MIDDLE CFQ]** (middle center frequency) range: 0.5k, 1.0k, 1.5k, 2.5k.
  - **[TREBLE]** range: -7 to +7.
  - **[TREBLE CFQ]** (treble center frequency) range: 10.0k, 12.5k, 15.0k, 17.5k.
  - **[RESUME]** : Resume the preset EQ value to factory default value.
- 3 Rotate **⊙** to select a value.

---

## 7 Adjust system settings

---

### Turn beep sound on/off

Each time you press a button, the unit beeps. You can turn off/on this beep sound.

- 1 Press **MENU**.
- 2 Press **▲** or **▼** repeatedly until **[BEEP]** is displayed.
- 3 Rotate **⊙** to select a setting:
  - **[BEEP ON]**: Turn on the beep sound.
  - **[BEEP OFF]**: Turn off the beep sound.

---

### Select blackout setting

You can set the screen to turn off automatically after the unit is idle for 10 or 20 seconds.

- 1 Press **MENU**.
- 2 Press **▲** or **▼** repeatedly until **[BLACK OUT]** is displayed.
- 3 Rotate **⊙** to select a setting:
  - **[BLK OUT 10 S]** : Turn off the screen automatically 10 seconds after last operation.
  - **[BLK OUT 20 S]** : Turn off the screen automatically 20 seconds after last operation.
  - **[BLK OUT OFF]** : Never turn off the screen.

---

### Turn demo mode on/off

- 1 Press **MENU**.
- 2 Press **▲** or **▼** repeatedly until **[DEMO]** is displayed.
  - ↳ The screen shows current Demo mode setting.

- 3 Rotate  $\odot$  to select a setting:
  - **[DEMO ON]**: Turn on the demo mode. When the unit is idle for more than 120 seconds, all functions are displayed.
  - **[DEMO OFF]**: Turn off the demo mode.

---

## Dimmer

- 1 Press **MENU**.
- 2 Press  $\blacktriangle$  or  $\blacktriangledown$  repeatedly until **[DIMMER]** is displayed.
- 3 Rotate  $\odot$  to select a setting:
  - **[DIMM HIGH]** (dimmer high)
  - **[DIMM LOW]** (dimmer low)

---

## Dance

You can turn on or off the spectrum on the LCD display.

- 1 Press **MENU**.
- 2 Press  $\blacktriangle$  or  $\blacktriangledown$  repeatedly until **[DANCE]** is displayed.
- 3 Rotate  $\odot$  to select a setting:
  - **[DANCE ON]**: Turn on the spectrum.
  - **[DANCE OFF]**: Turn off the spectrum.

---

## Rear Aux

- 1 Press **MENU**.
- 2 Press  $\blacktriangle$  or  $\blacktriangledown$  repeatedly until **[TEL MUTE]** is displayed.
- 3 Rotate  $\odot$  to select a setting:
  - **[NORMAL]**: Mute the telephone, **[MUTE]** is displayed.
  - **[REAR AUX]**: Mute the telephone, **[PHONE IN]** is displayed.

### Note

- To support telephone call with this unit, connect **TEL MUTING** wire to your hands-free kit and audio out jack to the **REAR AUX** in jack of the unit.

---

## LCD Color

You can select your desired LCD color on this car audio.

- 1 Press **MENU**.
- 2 Press  $\blacktriangle$  or  $\blacktriangledown$  repeatedly until **[LCD COLOR]** is displayed.
- 3 Press  $\odot$ .
- 4 Rotate  $\odot$  to select a setting:
  - **[DEFAULT]** (default setting)
  - **[COLOR SCAN]** (color scan)
  - **[WHITE]** (white)
  - **[GREEN 1]** (green 1)
  - **[GREEN 2]** (green 2)
  - **[GREEN 3]** (green 3)
  - **[AMBER]** (amber)
  - **[PINK 1]** (pink 1)
  - **[PINK 2]** (pink 2)
  - **[PURPLE 1]** (purple 1)
  - **[PURPLE 2]** (purple 2)
  - **[BLUE 1]** (blue 1)
  - **[BLUE 2]** (blue 2)
  - **[USER COLOR]** (user color)

---

## Audiobook

In iPod/iPhone mode, you can set the audiobook playback speed on this car audio.

- 1 Press **MENU**.
- 2 Press  $\blacktriangle$  or  $\blacktriangledown$  repeatedly until **[AUDIOBOOK]** is displayed.
- 3 Rotate  $\odot$  to select a setting:
  - **[FAST]**
  - **[SLOW]**
  - **[NORMAL]**

---

## Reset

You can reset the unit to its default setting.

- 1 Detach the front panel.
- 2 Press the reset button by using a ball-point pen or a similar tool.  
↳ Preset adjustments such as preset channels and sound adjustments are erased.

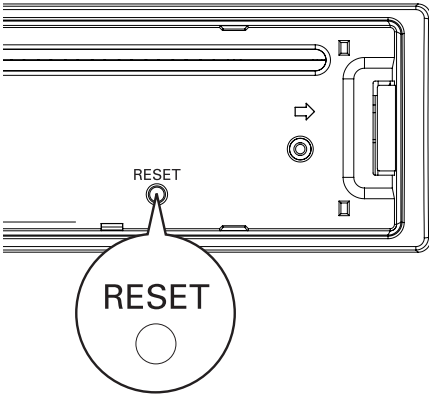

---

## 8 Additional information

---

### Detach the front panel

You can detach the front panel to deter theft.

- 1 Press  to release the panel.
- 2 Pull the panel towards you to disengage it from the classis.

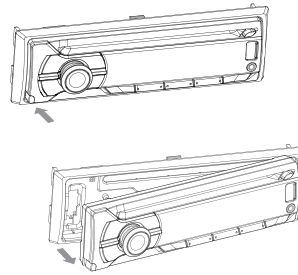

- 3 Store the panel in the supplied carrying case to protect it from dirt or damage.

---

### Replace fuse

If the fuse is damaged,

- 1 Check the electric connection.
- 2 Buy a fuse that matches the voltage of the damaged fuse.
- 3 Replace the fuse.

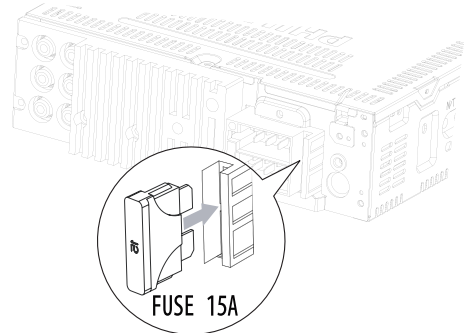

## Note

- If the new fuse gets damaged again, there may be an internal malfunction. Consult your dealer.

## Remove the unit

You can remove the unit from the dashboard.

- 1 Detach the front panel.
- 2 Pull out the unit by using the disassembly tools.

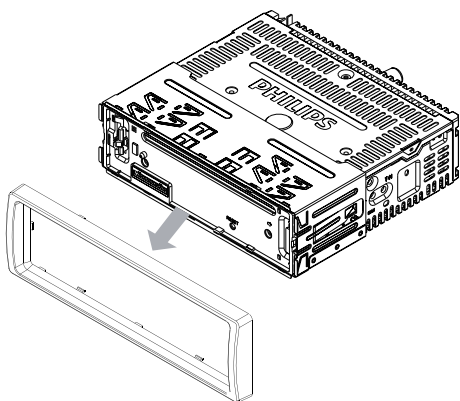

## 9 Product information

### Note

- Product information is subject to change without prior notice.

Power supply	12V DC (11V - 16V), negative ground
Fuse	15 A
Suitable speaker impedance	4 - 8 $\Omega$
Maximum power output	50 W $\times$ 4 channels
Continuous power output	24 W $\times$ 4 RMS (4 $\Omega$ 10% T.H.D.)
Pre-Amp output voltage	2.5V
Aux-in level	$\geq$ 500 mV
Dimensions (W $\times$ H $\times$ D)	181.5 $\times$ 52 $\times$ 191.4 mm
Weight	1.32 kg

### Radio

Frequency range - FM	87.5 - 108.0 MHz (100 kHz per step in auto search and 50 kHz per step in manual search)
Frequency range - AM(MW)	522 - 1620 KHz (9 kHz) 530 - 1710 kHz (10 kHz)
Usable sensitivity - FM	8 $\mu$ V
Usable sensitivity - AM(MW) (S/N = 20 dB)	30 $\mu$ V

### Compatible USB devices:

- USB flash memory: USB 1.1 host with interface reading all speed support (1.1, 2.0)
- USB flash players: USB 1.1 host with interface reading all speed support (1.1, 2.0)

### Supported formats:

- USB or memory file format: FAT16, FAT32
- MP3 bit rate (data rate): 32-320 Kbps and variable bit rate
- WMA V4, V7, V8, V9 (L1, L2)
- ISO9660, Joliet
- Supported sampling frequencies: 2 kHz, 44.1 kHz, 48 kHz
- Supported Bit-rates: 2~256 (kbps), variable bit rates
- Directory nesting up to a maximum of 8 levels
- Number of albums/ folders: CD maximum 99, USB maximum 99
- Number of tracks/titles: maximum 999
- ID3 tag v2.0 or later

### Unsupported formats:

- Empty albums: an empty album is an album that does not contain MP3/WMA files, and is not be shown in the display.
- Unsupported file formats are skipped. For example, Word documents (.doc) or MP3 files with extension .dlf are ignored and not played.
- AAC, WAV, PCM audio files
- DRM protected WMA files (.wav, .m4a, .m4p, .mp4, .aac)
- WMA files in Lossless format

# 10 Troubleshooting



### Caution

- Never remove the casing of this apparatus.

To keep the warranty valid, never try to repair the system yourself.

If you encounter problems when using this apparatus, check the following points before requesting service. If the problem remains unsolved, go to the Philips web site ([www.philips.com/support](http://www.philips.com/support)). When you contact the Consumer Care, make sure that the product is nearby and the model number and serial number are available.

### No power or no sound.

- Car engine is not on. Turn the car engine on.
- Cable is not correctly connected. Check connections.
- Fuse is burnt. Replace fuse.
- Volume is too low. Adjust volume.
- If the above solutions cannot help, press the RESET button.
- Ensure that the track played is of a compatible format.

### Noise in broadcasts.

- Signals are too weak. Select other stations with stronger signals.
- Check the connection of the car antenna.
- Change broadcast from Stereo to mono.

### Cannot play disc

- Ensure that the disc label is inserted with the printed side facing up.
- Wipe the disc with fibre cleaning cloth from the centre to the edge in a straight line.
- This disc may be defective. Play another disc.
- Ensure that the CD is a finalised CD/CD-R/CD-RW.
- Ensure that the CD is not encoded with copyright protection technologies.

### **The CD skips tracks**

- Ensure that the CD is not damaged or dirty.
- Ensure that random mode is deactivated.

### **Disc cannot be ejected**

- Press and hold ▲.

### **Preset stations lost.**

- Battery cable is not correctly connected.  
Connect the battery cable to the terminal that is always live.

### **Display show ERR-12**

- USB data error. Check the USB device.

# 11 Glossary

---

## M

### **MP3**

A file format with a sound data compression system. MP3 is the abbreviation of Motion Picture Experts Group 1 (or MPEG-1) Audio Layer 3. With the MP3 format, one CD-R or CD-RW can contain about 10 times more data than a regular CD.

---

## W

### **WMA (Windows Media Audio)**

An audio format owned by Microsoft, is a part of Microsoft Windows Media technology. Includes Microsoft Digital Rights Management tools, Windows Media Video encoding technology, and Windows Media Audio encoding technology.





2014 © WOOX Innovations Limited. All rights reserved.  
Philips and the Philips' Shield Emblem are registered  
trademarks of Koninklijke Philips N.V. and are used by WOOX  
Innovations Limited under license from Koninklijke Philips N.V.

CEM3100\_12\_UM\_V4.0

