

PARTS MANUAL

Model

**RGX3000
GENERATOR**

PUB-GP6794
Rev. 07/09

Robin America, Inc.

905 Telser Road • Lake Zurich, IL 60047 • Phone: 847-540-7300 • Fax: 847-438-5012
e-mail: sales@robinamerica.com • www.subarupower.com

© Copyright 2009 Robin America, Inc.

HOW TO USE THIS MANUAL

Robin engines are identified by MODEL, SPECIFICATION, and CODE NUMBER. For each model there may be many different versions called specifications. Each specification will be unique in some way. The difference may only be the paint color or it may have a different type of PTO or some other significant difference.

In order to identify the correct service part number, it is important to confirm the specification and code numbers for your engine. The specification and code number together are known as the PRODUCT NUMBER.

All Robin 4 cycle engines have a Product Number label similar to the label illustrated below.

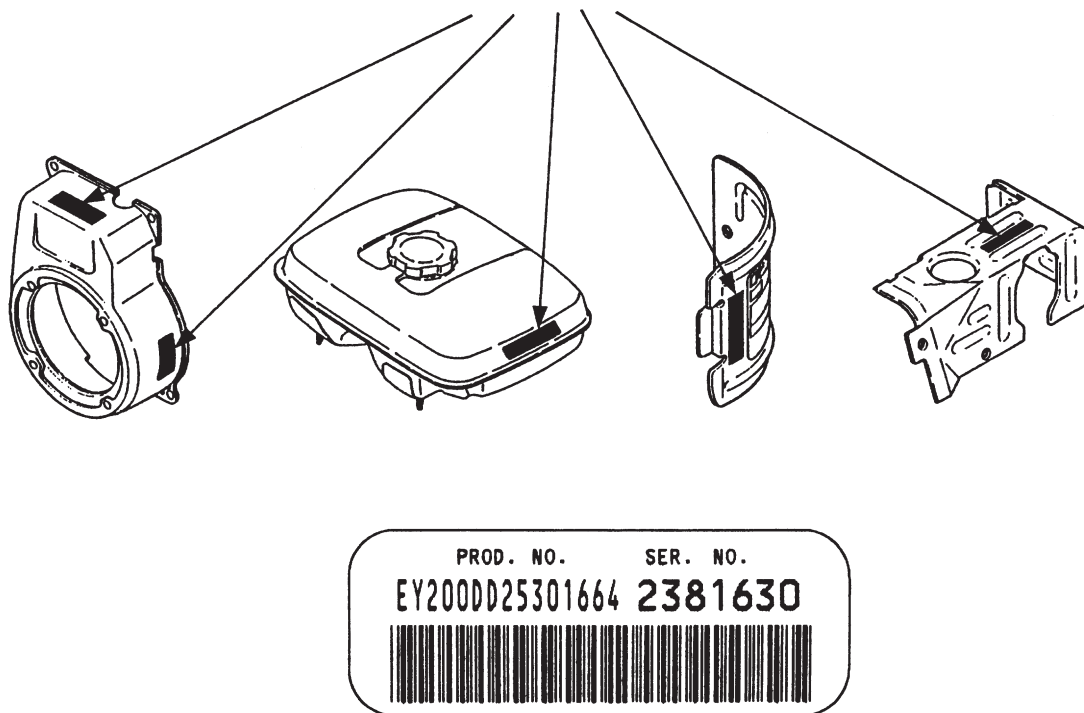

The Product Number Label has a 15 digit alphanumeric string that consists of the SPECIFICATION (SPEC) number (11 digits) and the CODE number (4 digits). Please note the illustration below:

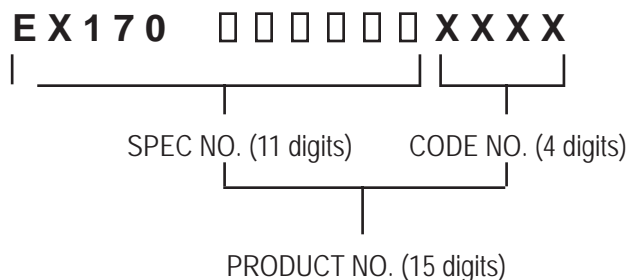

MANUAL LAYOUT

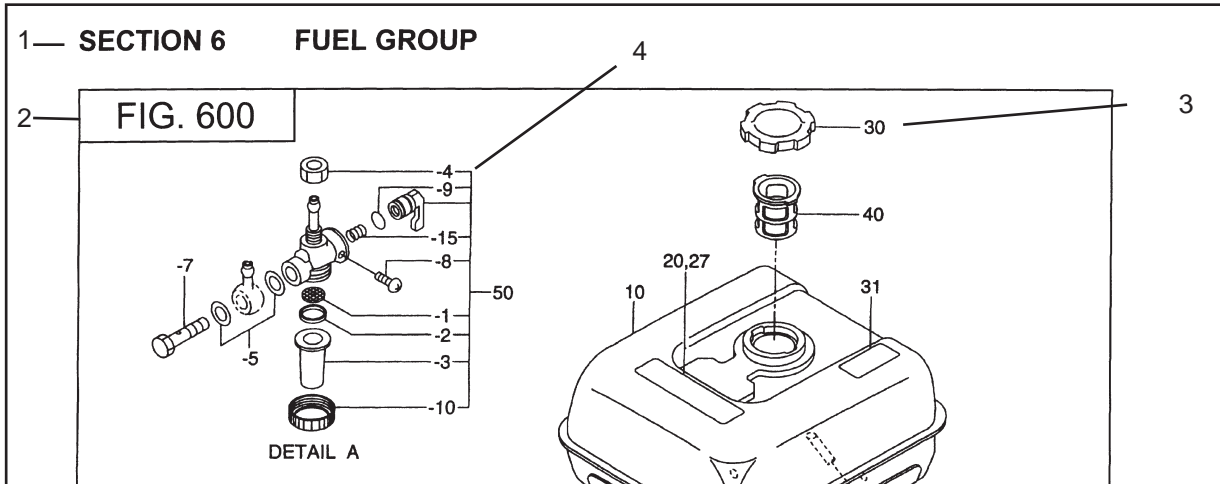

REF.	PART NO.	DESCRIPTION	QTY.	REMARKS	FROM-TO	FIG.
10	267-60103-01	FUEL TANK CP	1	YD, YS TYPE, BLACK		600
	267-60101-01	FUEL TANK CP	1	YELLOW		600
27	073-20039-00	LABEL, WARNING	1	YD, YS TYPE		600
30	043-04300-15	FUEL TANK CAP CP	1			600
31	267-95201-03	LABEL, EMISSION	1	YD, YS TYPE		600
40	064-13600-10	FUEL FILTER	1			600
50	064-20021-01	FUEL STRAINER AY	1			600
-1	064-20002-20	FILTER	1			600
-2	064-20002-30	GASKET	1			600
-3	064-20019-10	CUP	1			600

1. SECTION NAME Parts are broadly classified according to their functions. Refer to the Group Index (table of contents) for respective section name.
2. FIG. No. The FIG. number indexes the reference and part numbers to the illustration. Figure numbers that vary only in the tens place (i.e.: 700 and 710) are in a group of the same section (i.e.: Electrical Device Group).
3. REF. No. The Reference number identifies the part illustration with the corresponding part number in the part list.
4. SUBASSEMBLY SUBASSEMBLY parts of part assembly are listed below the assembly part. The subassembly part reference number is indicated by the number led by "-" such as "-1", "-2".
5. PART NUMBER It is the number assigned for sales unit. Use the PART No. when making an order.
6. DESCRIPTION It is designation of the part.
7. QTY. Quantity of each part used for each product.
8. REMARKS This gives a distinctive feature and/or a supplementary comment for the type, the specification, and the part concerned. It also shows part number(s) interchangeable for the part.
9. FROM-TO This section shows the CODE No. to indicate the history of progress in which improved parts have been introduced in the product. The FROM-TO CODE No. helps to identify PART No. being employed in the product concerned. See the examples below:
 - The part is used in the product irrespective of CODE No.
 - 2101- The part is used in the products with CODE No. of 2101 and after this number.
 - 2100 The part is used in the products with CODE No. of 2100 and before this number.

GROUP INDEX

Group Name	Page
CRANKCASE GROUP	6
CRANKSHAFT GROUP	8
INTAKE and EXHAUST GROUP	10
GOVERNOR GROUP	14
COOLING and STARTING GROUP	16
FUEL, LUBRICANT GROUP	18
CARBURETOR GROUP	20
ELECTRIC DEVICE GROUP	22
GENERATOR GROUP	24

INDEX OF DESCRIPTION SYMBOLS			
SYMBOL	DESCRIPTION	SYMBOL	DESCRIPTION
AY	ASSEMBLY	P=	PITCH (in mm)
CP	COMPLETE	P.T.O. (PTO)	POWER TAKE OFF
EX	EXPORT (from Japan)	REF	REFERENCE
FIG	FIGURE	R.H. (RH)	RIGHT HAND SIDE
FR	FRONT	RR	REAR
"	INCH	STD.	STANDARD
INCL.	INCLUDE	SW	SWITCH
-L	LITER	T=	THICKNESS (in mm)
L=	LENGTH (in. mm)	UN	UNIT
L.H. (LH)	LEFT-HAND SIDE	U.S.	UNDER SIZE
MECH	MECHANICAL	~V	VOLTAGE
NO (NON)	NONE	~W	WATT
OPT	OPTIONAL	W/	WITH
O.S.	OVER SIZE	W/O	WITHOUT

SECTION 1 CRANKCASE GROUP

FIG. 100

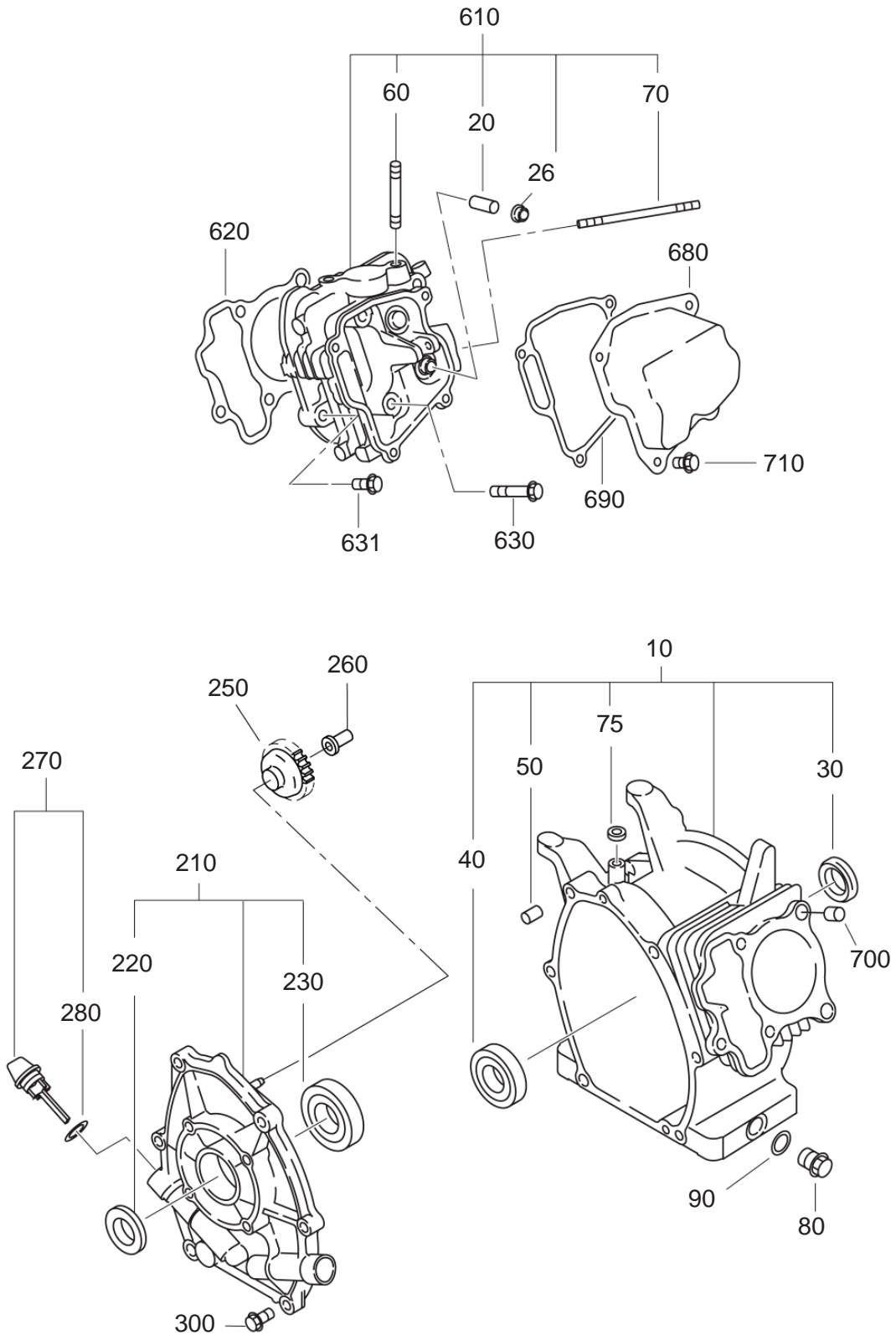

SECTION 2 CRANKSHAFT GROUP

FIG. 200

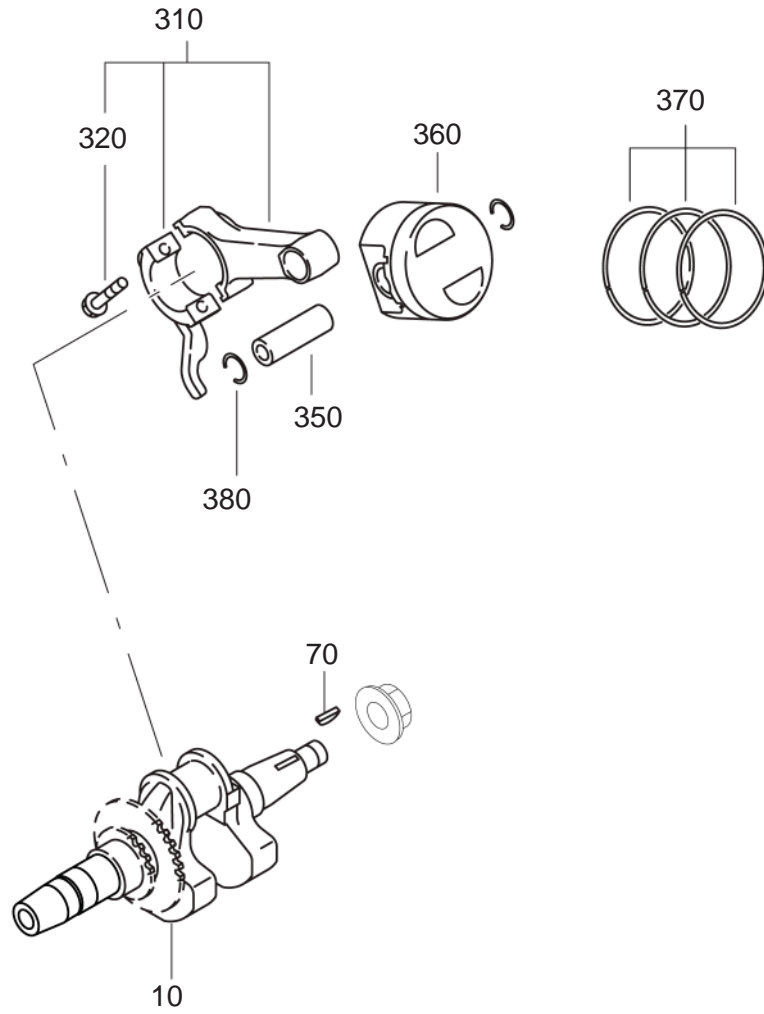

SECTION 3 INTAKE and EXHAUST GROUP

FIG. 300

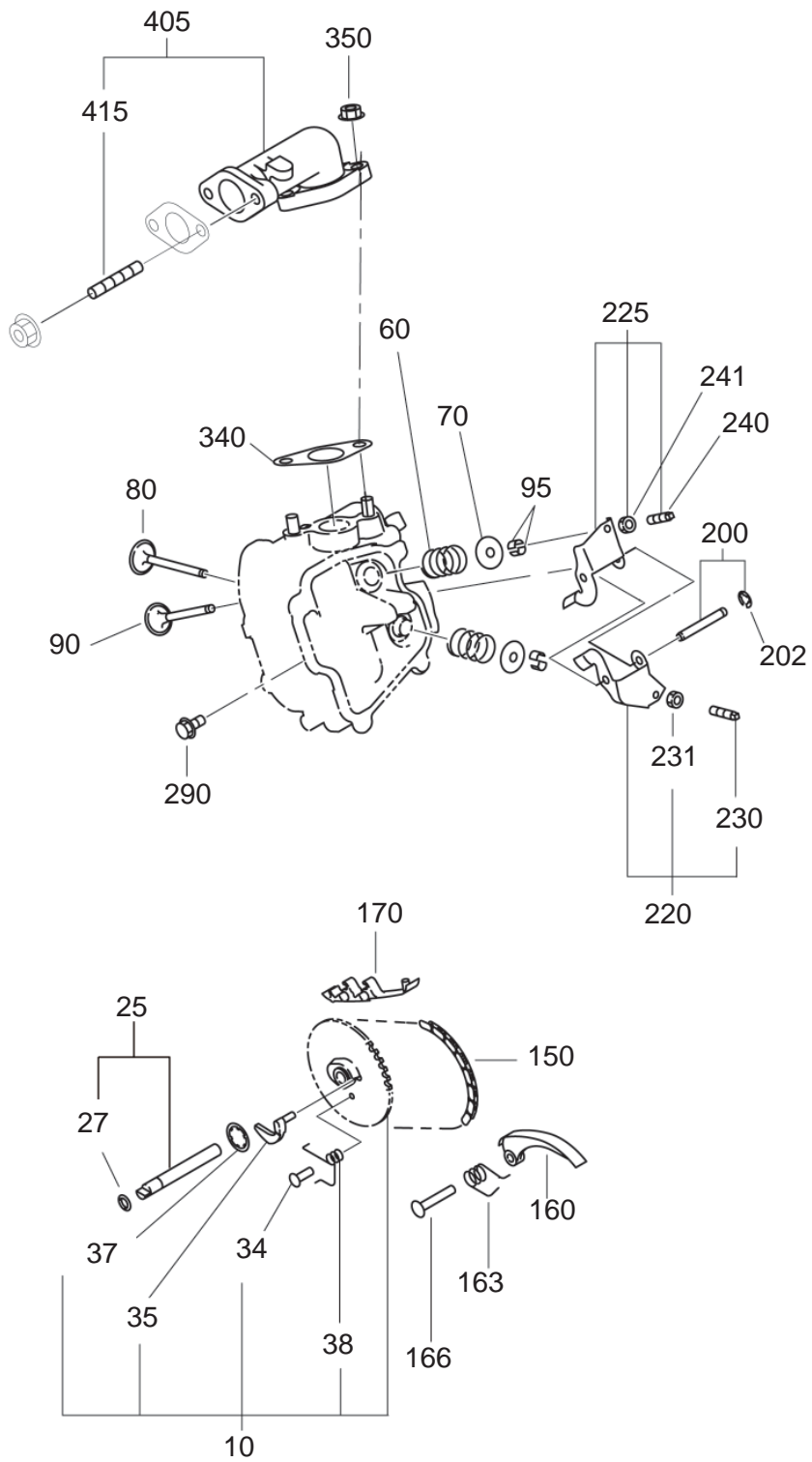

SECTION 3 INTAKE and EXHAUST GROUP

FIG. 315

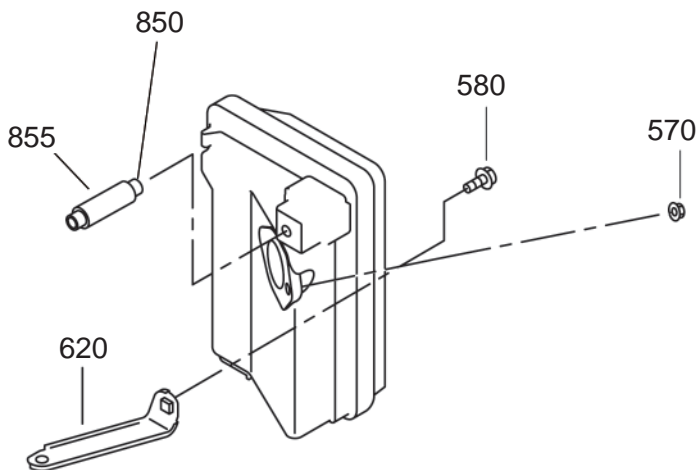

510

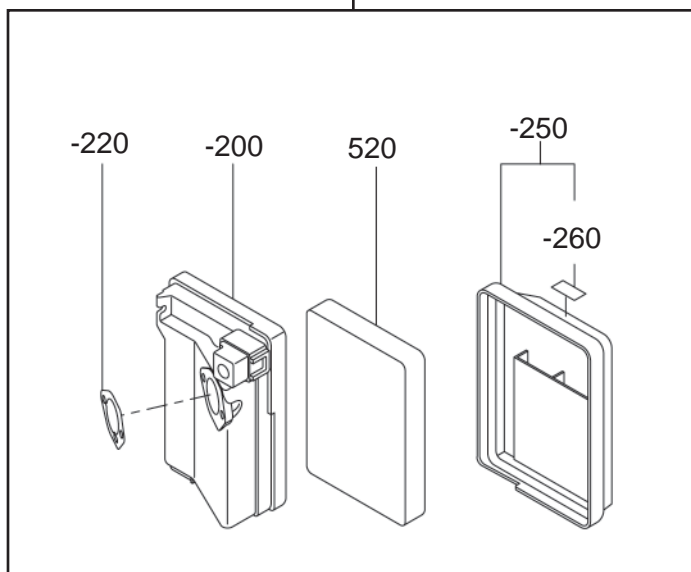

SECTION 4 GOVERNOR GROUP

FIG. 400

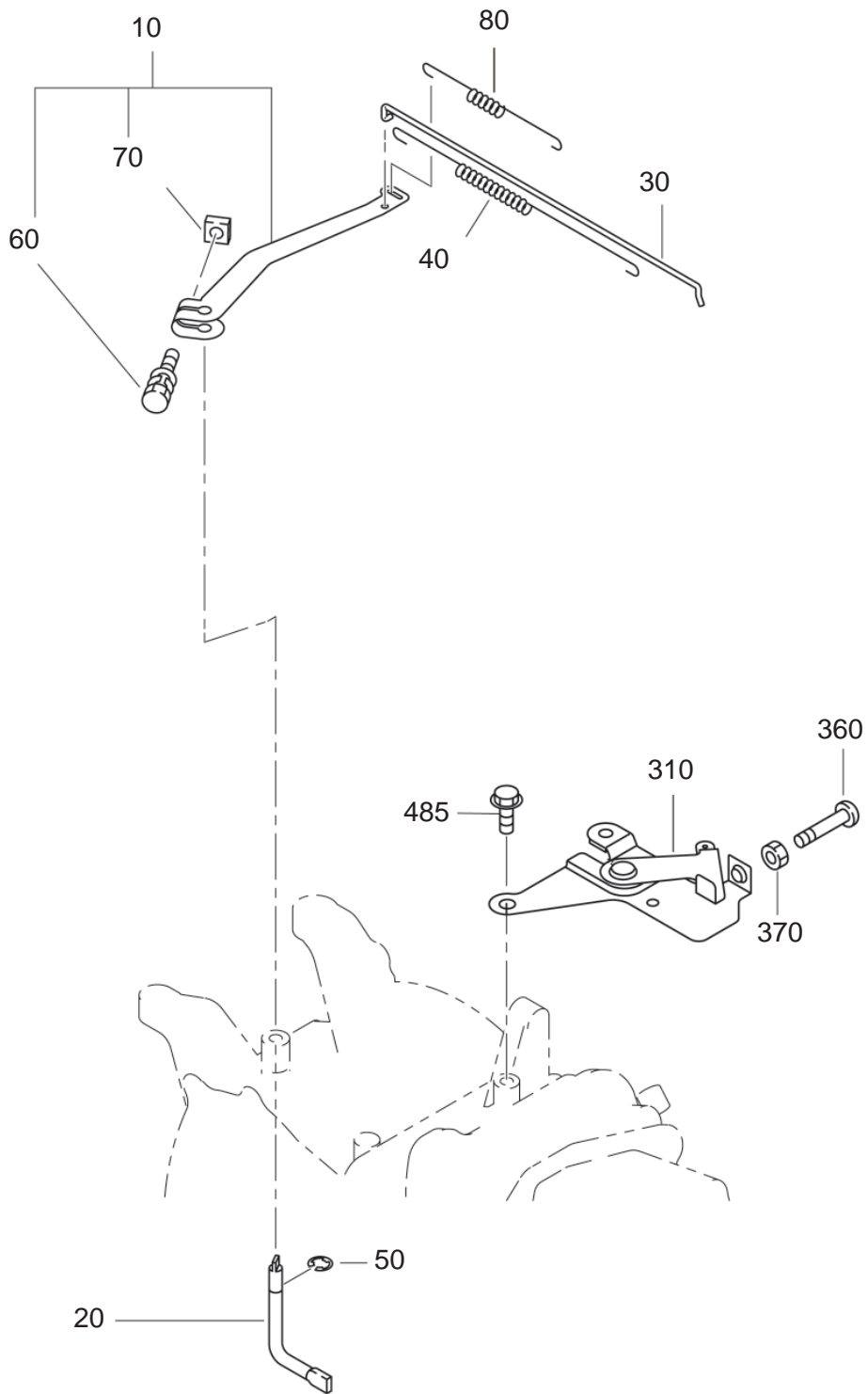

SECTION 5 COOLING and STARTING GROUP

FIG. 500

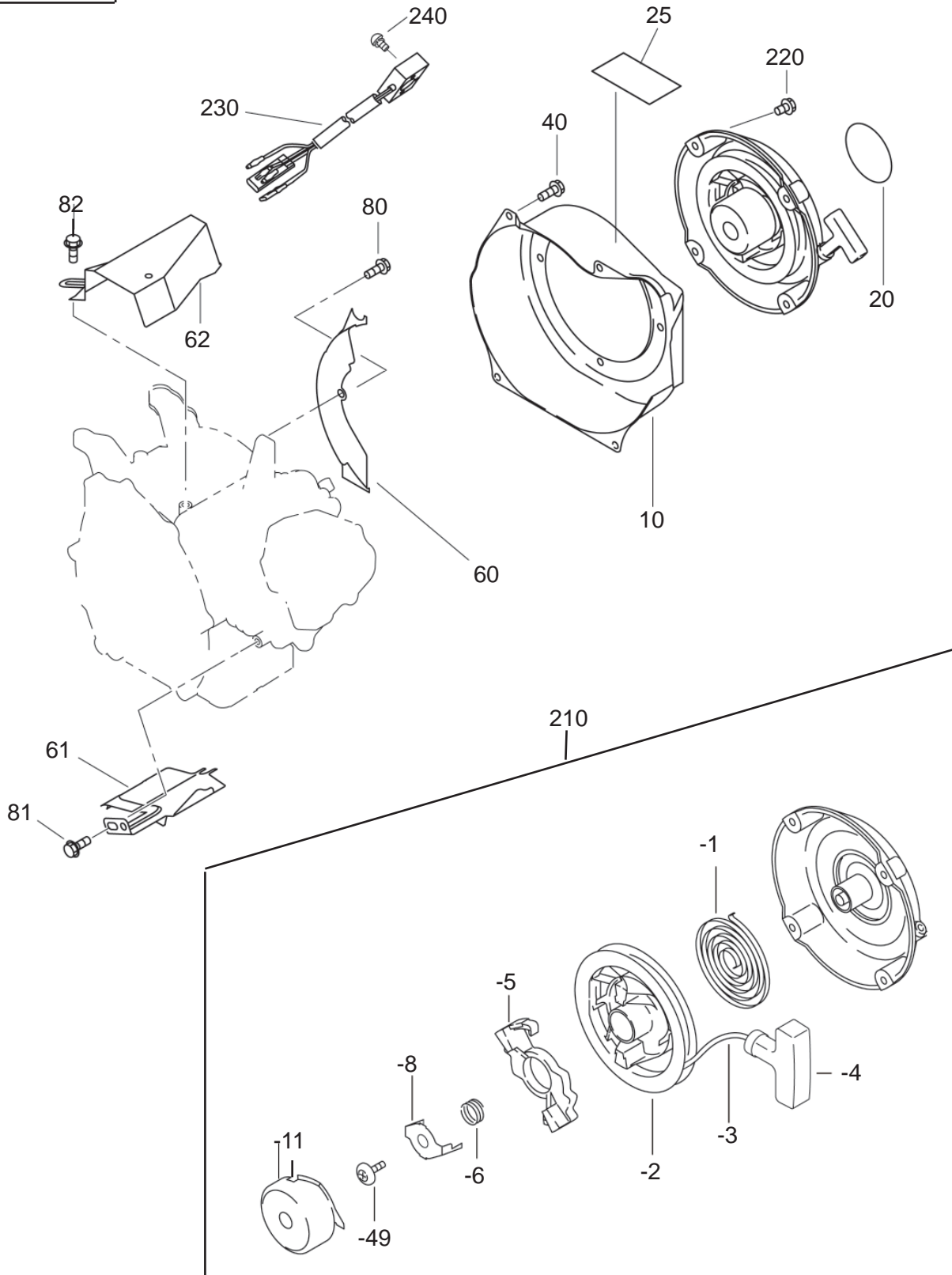

SECTION 6 FUEL, LUBRICATION GROUP

FIG. 600

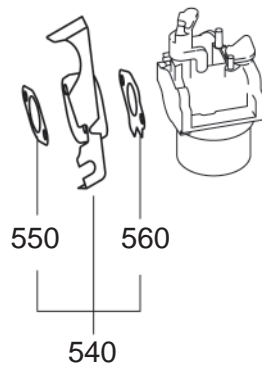

SECTION 6 FUEL, LUBRICATION GROUP

FIG. 640

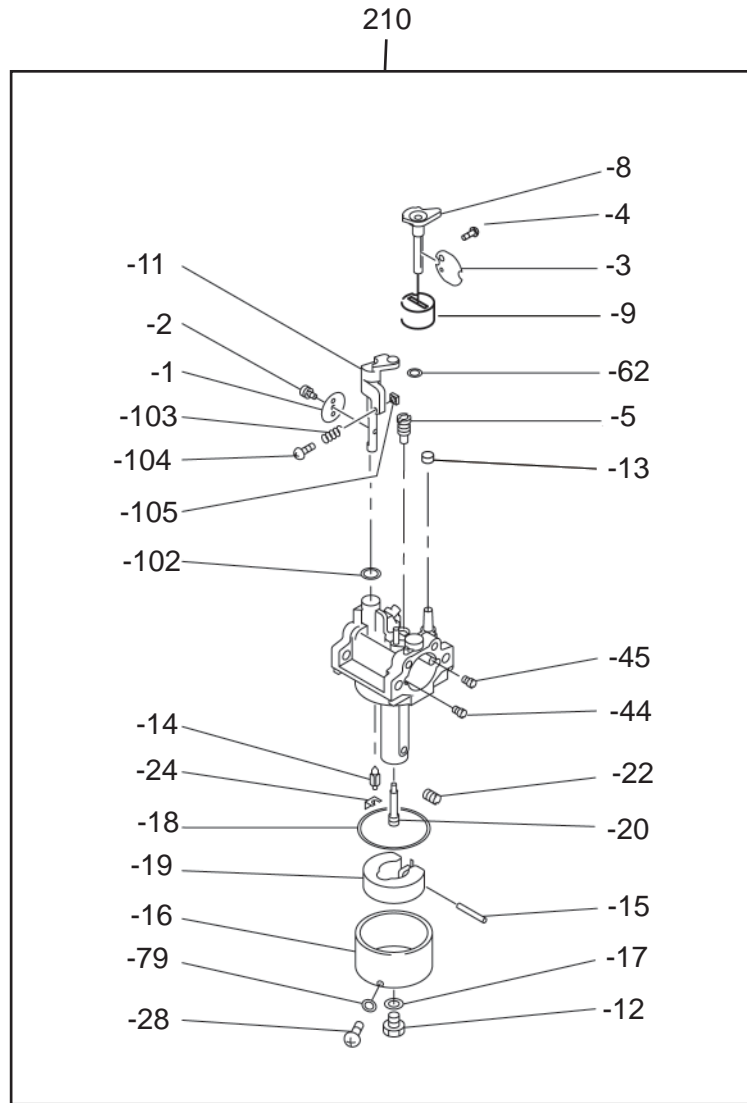

SECTION 7 ELECTRIC DEVICE GROUP

FIG. 700

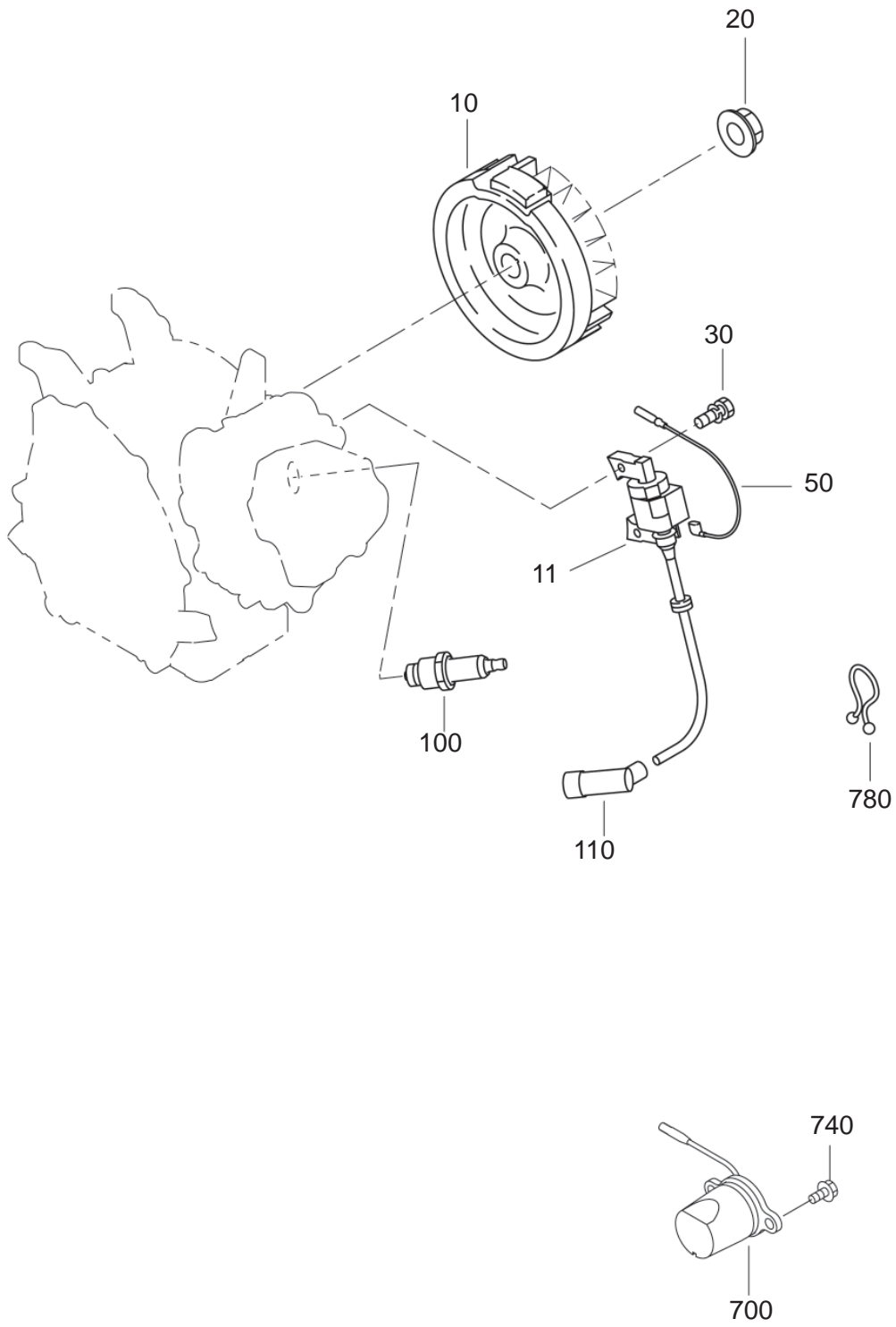

SECTION 21 ENGINE GROUP

FIG. 2130

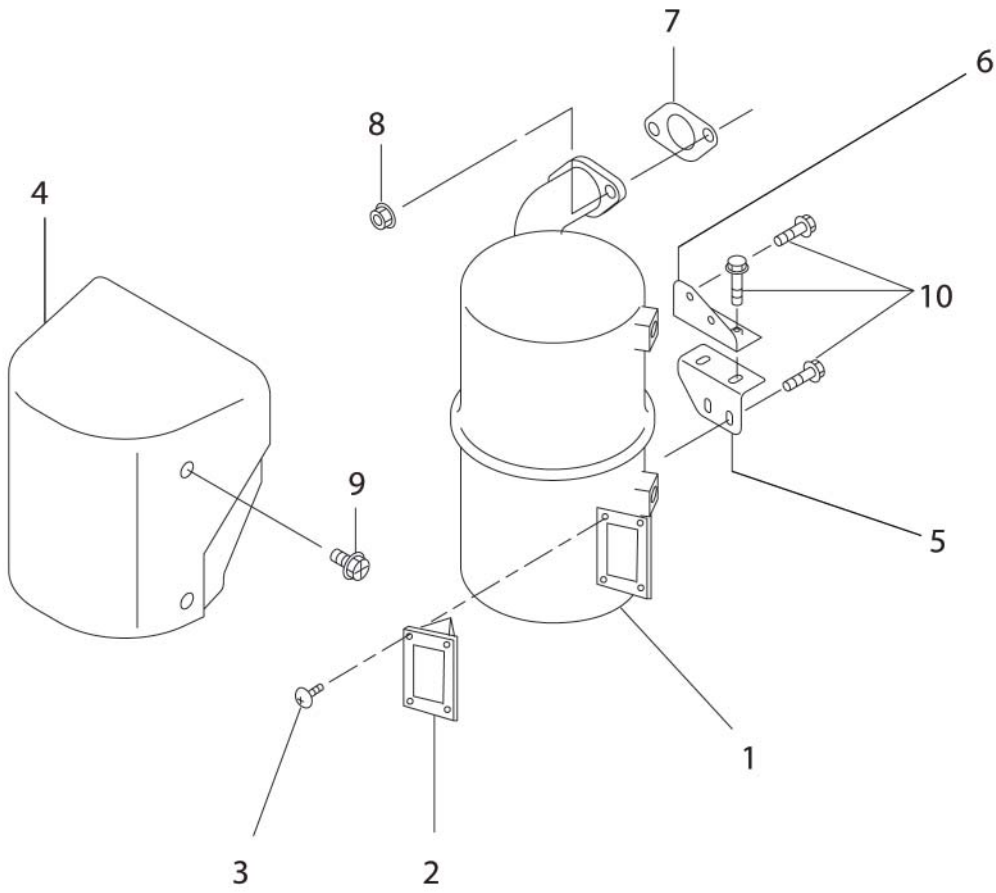

SECTION 22 GENERATOR GROUP

FIG. 2200

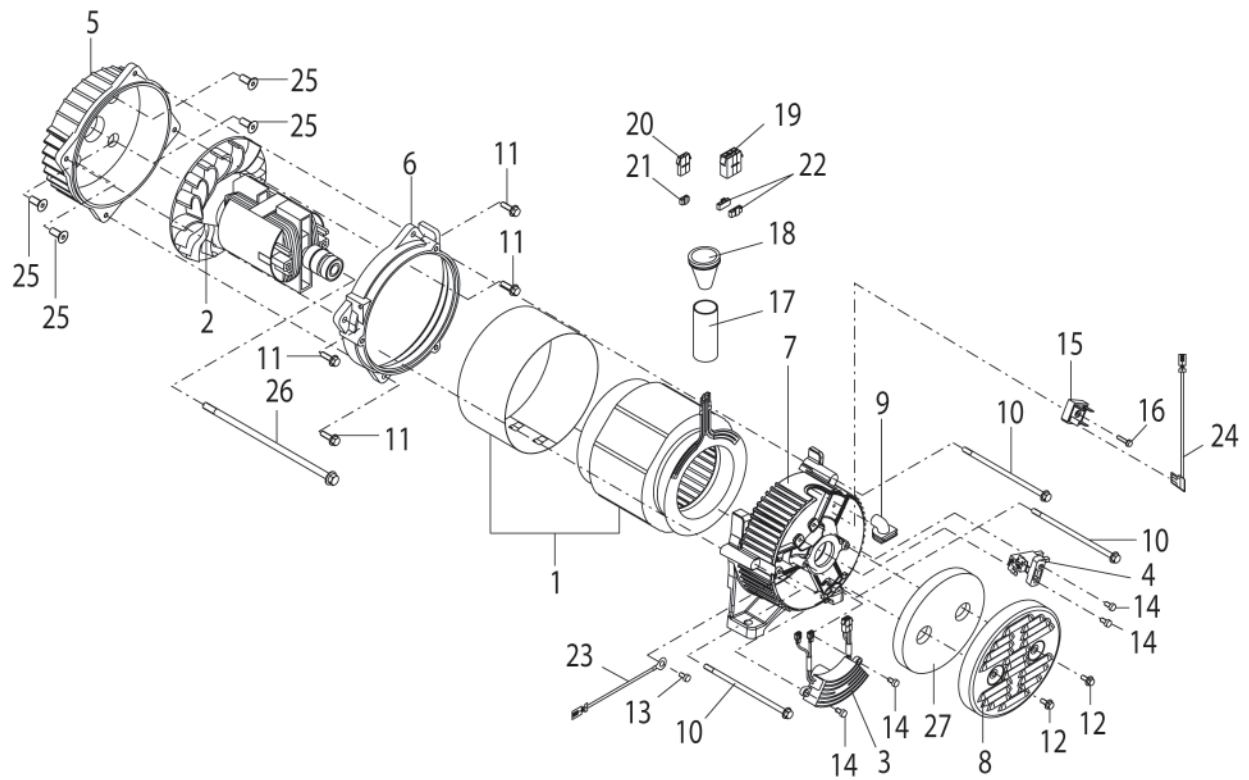

SECTION 23 BASE, FRAME GROUP

FIG. 2300

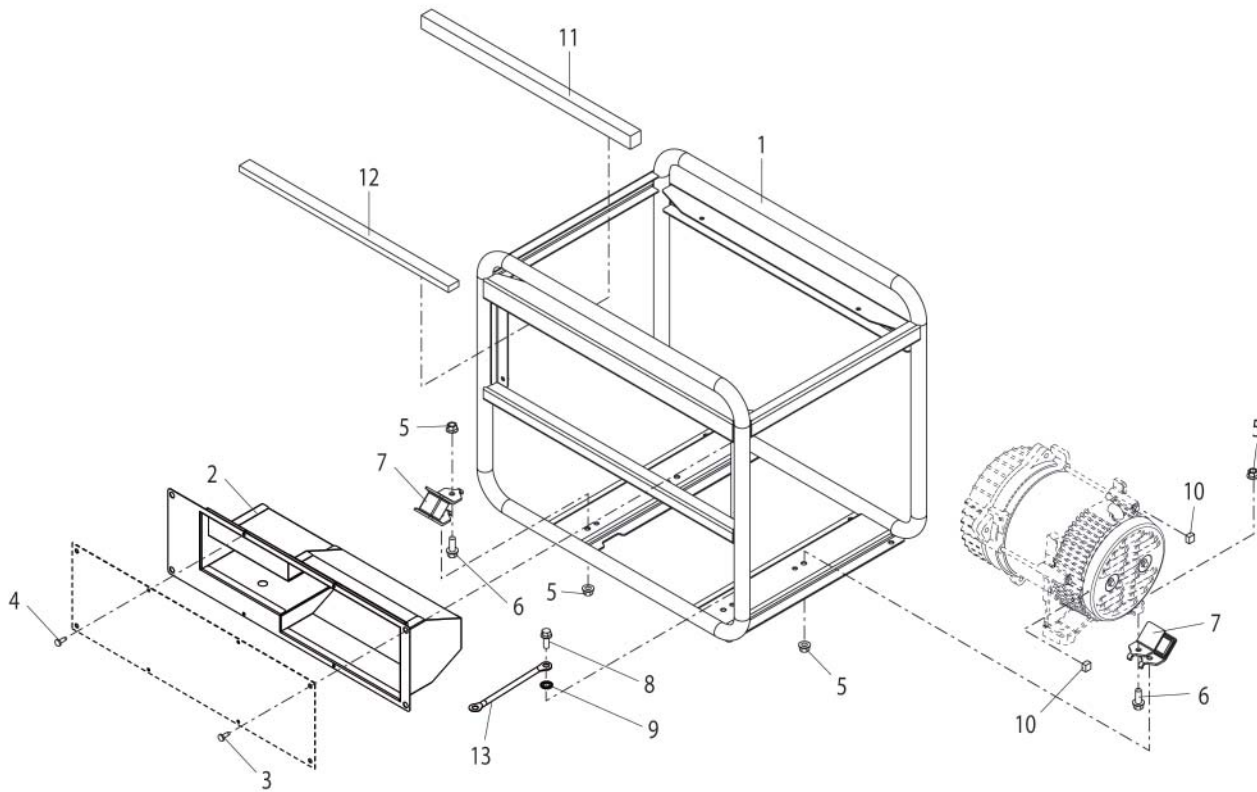

SECTION 24 CONTROL GROUP

FIG.2400

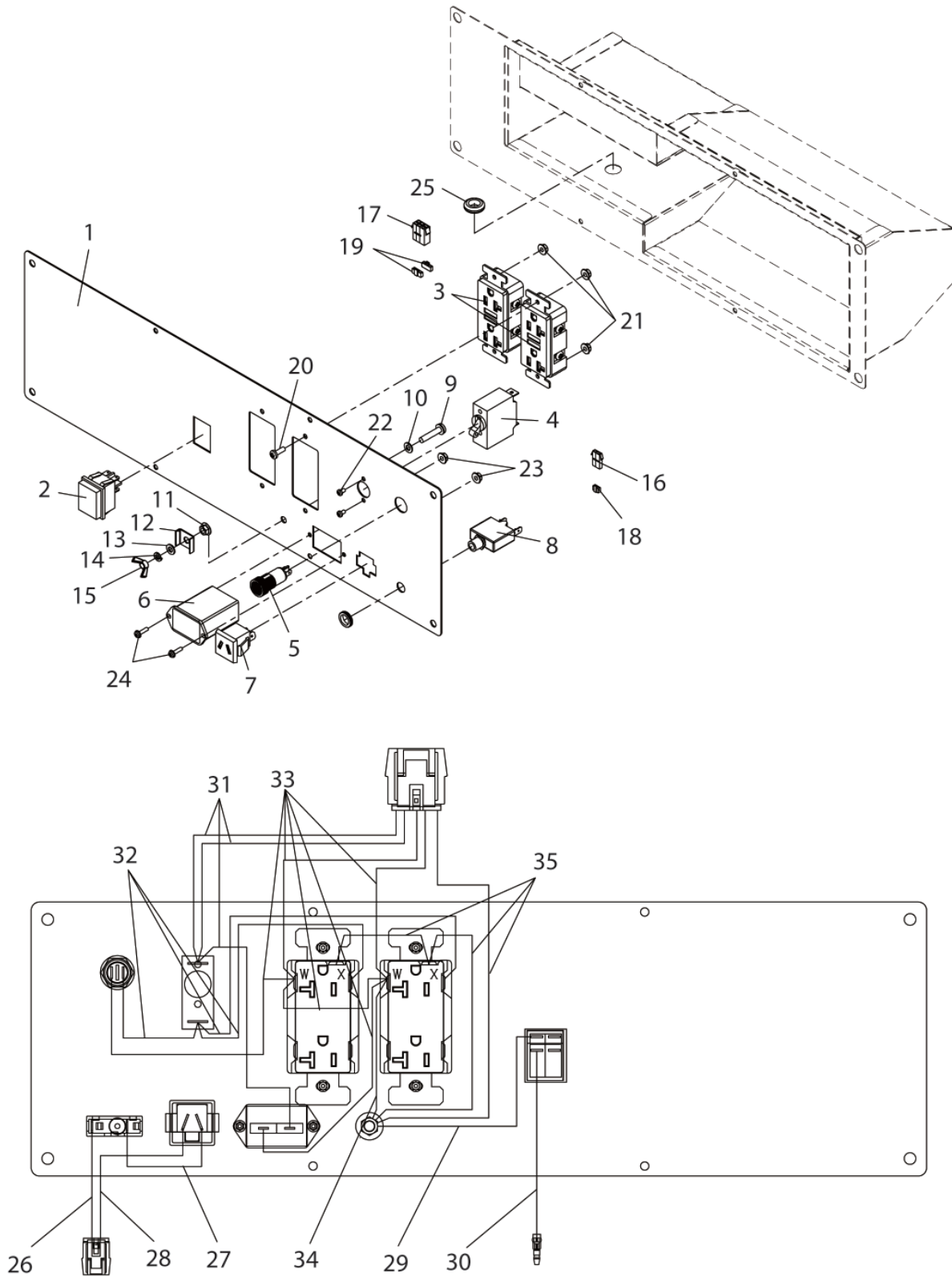

SECTION 26 FUEL TANK GROUP

FIG.2600

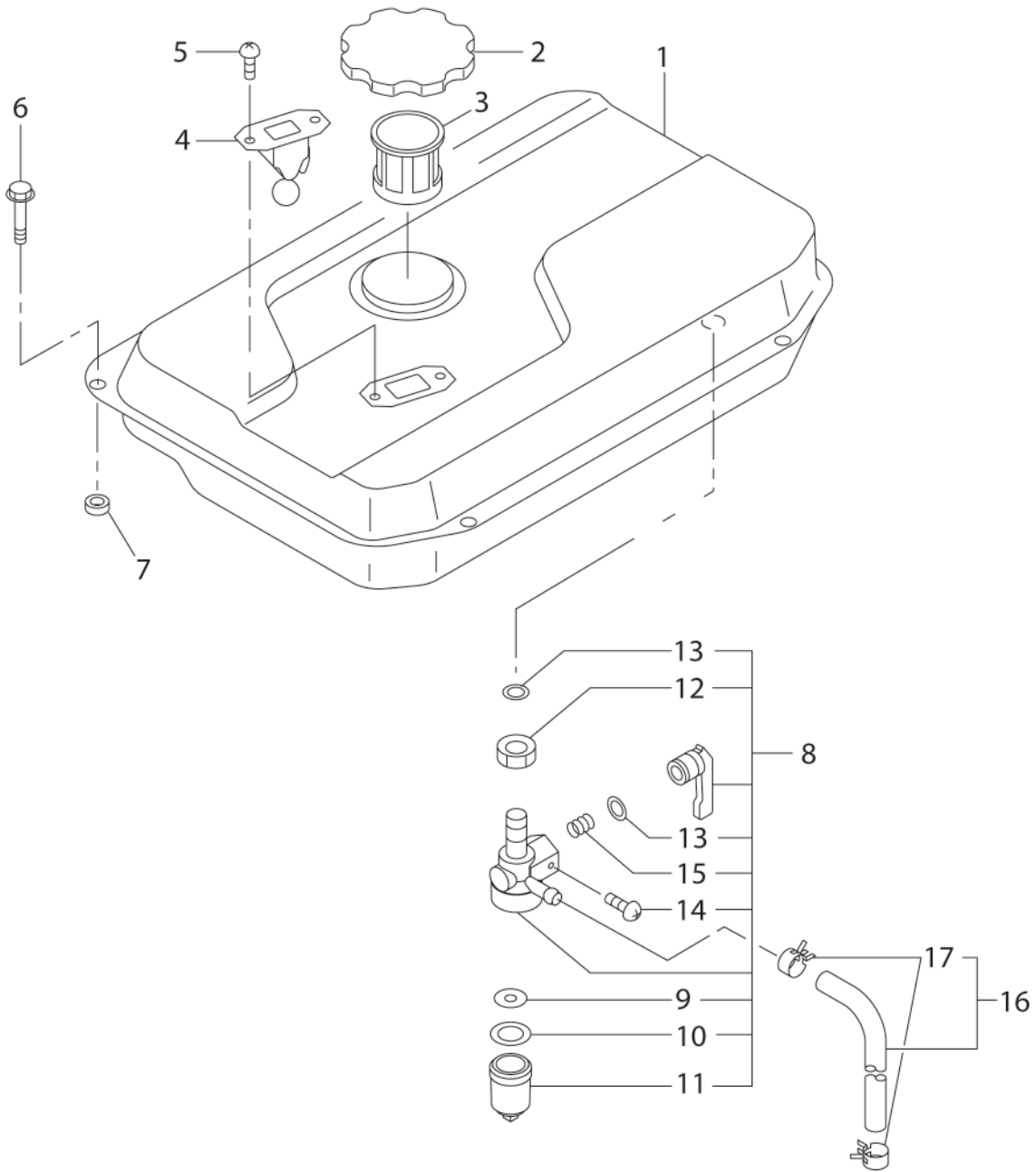

SECTION 29 ACCESSORY GROUP

FIG.2900

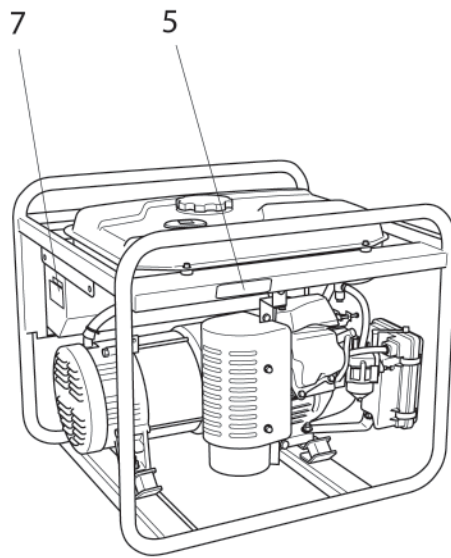
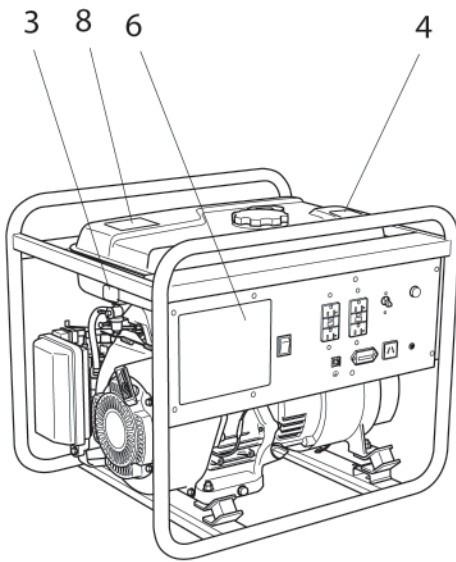
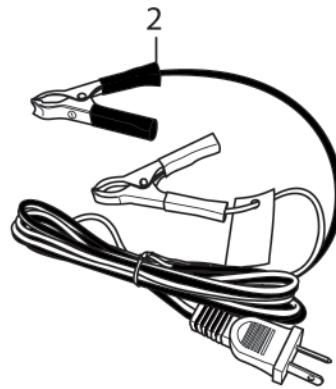
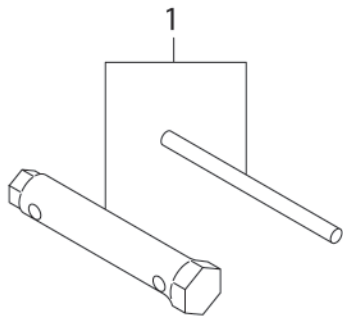

PRINTED IN THE USA