

# **PARTS MANUAL**

**Model**

**RGX5100  
GENERATOR**

PUB-GP6767  
Rev. 07/09

**Robin America, Inc.**

905 Telser Road • Lake Zurich, IL 60047 • Phone: 847-540-7300 • Fax: 847-438-5012  
*e-mail: [sales@robinamerica.com](mailto:sales@robinamerica.com) • [www.subarupower.com](http://www.subarupower.com)*

© Copyright 2009 Robin America, Inc.

## HOW TO USE THIS MANUAL

Robin engines are identified by MODEL, SPECIFICATION, and CODE NUMBER. For each model there may be many different versions called specifications. Each specification will be unique in some way. The difference may only be the paint color or it may have a different type of PTO or some other significant difference.

In order to identify the correct service part number, it is important to confirm the specification and code numbers for your engine. The specification and code number together are known as the PRODUCT NUMBER.

All Robin 4 cycle engines have a Product Number label similar to the label illustrated below.

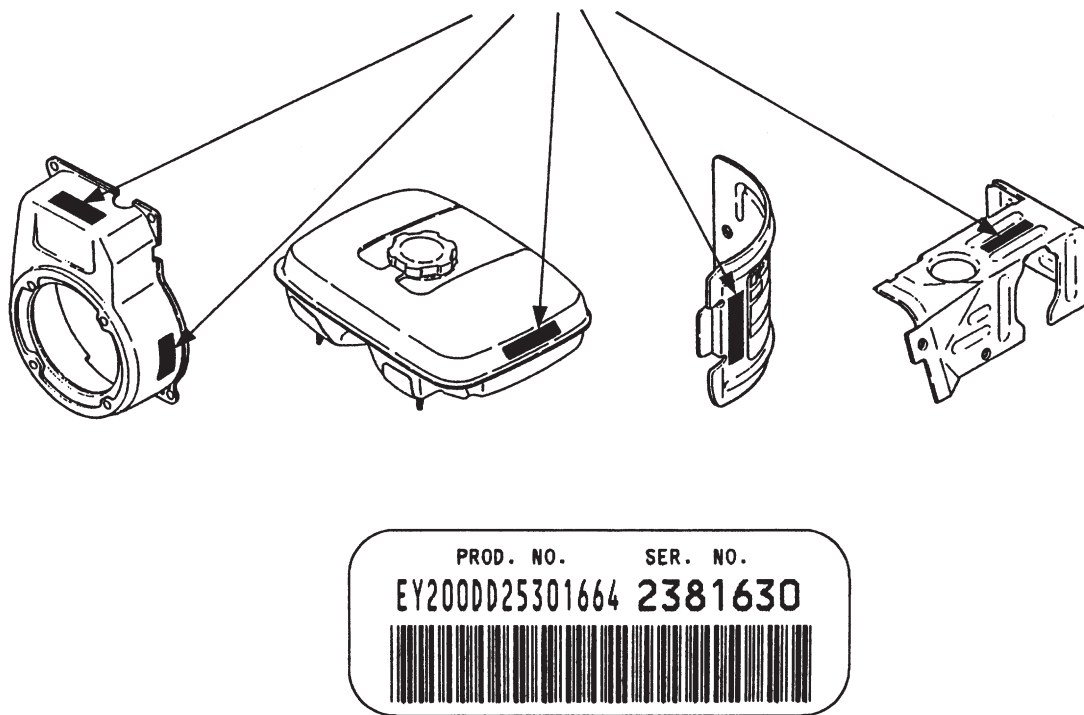

The Product Number Label has a 15 digit alphanumeric string that consists of the SPECIFICATION (SPEC) number (11 digits) and the CODE number (4 digits). Please note the illustration below:

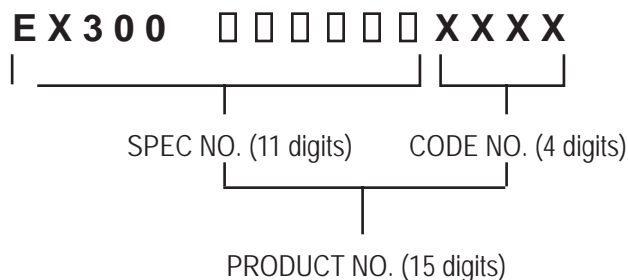

# MANUAL LAYOUT

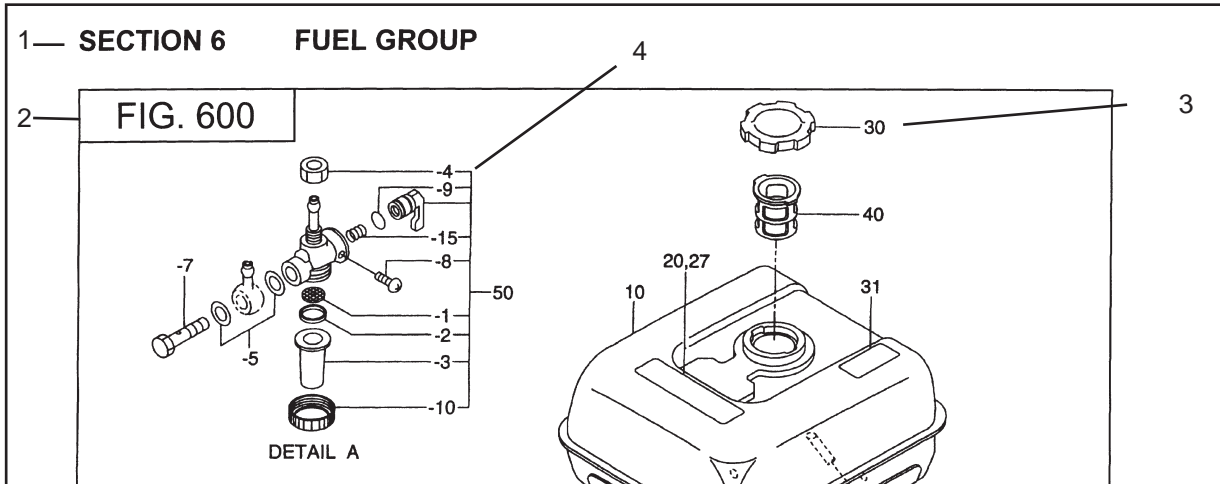

REF.	PART NO.	DESCRIPTION	QTY.	REMARKS	FROM-TO	FIG.
10	267-60103-01	FUEL TANK CP	1	YD, YS TYPE, BLACK		600
	267-60101-01	FUEL TANK CP	1	YELLOW		600
27	073-20039-00	LABEL, WARNING	1	YD, YS TYPE		600
30	043-04300-15	FUEL TANK CAP CP	1			600
31	267-95201-03	LABEL, EMISSION	1	YD, YS TYPE		600
40	064-13600-10	FUEL FILTER	1			600
50	064-20021-01	FUEL STRAINER AY	1			600
-1	064-20002-20	FILTER	1			600
-2	064-20002-30	GASKET	1			600
-3	064-20019-10	CUP	1			600

1. SECTION NAME      Parts are broadly classified according to their functions. Refer to the Group Index (table of contents) for respective section name.
2. FIG. No.            The FIG. number indexes the reference and part numbers to the illustration. Figure numbers that vary only in the tens place (i.e.: 700 and 710) are in a group of the same section (i.e.: Electrical Device Group).
3. REF. No.            The Reference number identifies the part illustration with the corresponding part number in the part list.
4. SUBASSEMBLY      SUBASSEMBLY parts of part assembly are listed below the assembly part. The subassembly part reference number is indicated by the number led by "-" such as "-1", "-2".
5. PART NUMBER      It is the number assigned for sales unit. Use the PART No. when making an order.
6. DESCRIPTION      It is designation of the part.
7. QTY.                Quantity of each part used for each product.
8. REMARKS            This gives a distinctive feature and/or a supplementary comment for the type, the specification, and the part concerned. It also shows part number(s) interchangeable for the part.
9. FROM-TO            This section shows the CODE No. to indicate the history of progress in which improved parts have been introduced in the product. The FROM-TO CODE No. helps to identify PART No. being employed in the product concerned. See the examples below:
  - The part is used in the product irrespective of CODE No.
  - 2101-                 The part is used in the products with CODE No. of 2101 and after this number.
  - 2100                The part is used in the products with CODE No. of 2100 and before this number.

# GROUP INDEX

Group Name	Page
CRANKCASE GROUP .....	6
CRANKSHAFT GROUP .....	8
INTAKE and EXHAUST GROUP .....	10
GOVERNOR GROUP .....	14
COOLING and STARTING GROUP .....	16
FUEL, LUBRICANT GROUP .....	18
CARBURETOR GROUP .....	20
ELECTRIC DEVICE GROUP .....	22
GENERATOR GROUP .....	30

INDEX OF DESCRIPTION SYMBOLS			
SYMBOL	DESCRIPTION	SYMBOL	DESCRIPTION
AY .....	ASSEMBLY	P= .....	PITCH (in mm)
CP .....	COMPLETE	P.T.O. (PTO) .....	POWER TAKE OFF
EX .....	EXPORT (from Japan)	REF .....	REFERENCE
FIG .....	FIGURE	R.H. (RH) .....	RIGHT HAND SIDE
FR .....	FRONT	RR .....	REAR
" .....	INCH	STD. ....	STANDARD
INCL. ....	INCLUDE	SW .....	SWITCH
-L .....	LITER	T= .....	THICKNESS (in mm)
L= .....	LENGTH (in. mm)	UN .....	UNIT
L.H. (LH) .....	LEFT-HAND SIDE	U.S. ....	UNDER SIZE
MECH .....	MECHANICAL	~V .....	VOLTAGE
NO (NON) .....	NONE	~W .....	WATT
OPT .....	OPTIONAL	W/ .....	WITH
O.S. ....	OVER SIZE	W/O .....	WITHOUT





SECTION 2 CRANKSHAFT GROUP

FIG. 200

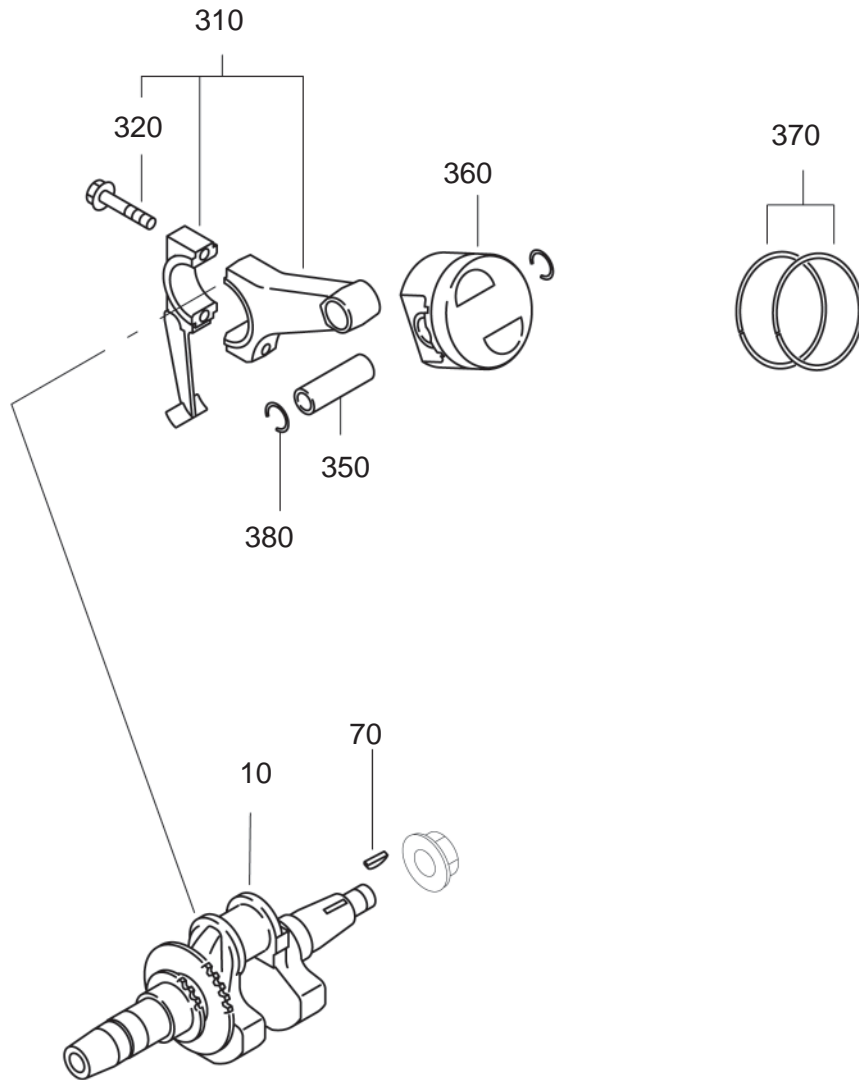



SECTION 3 INTAKE and EXHAUST GROUP

FIG. 300

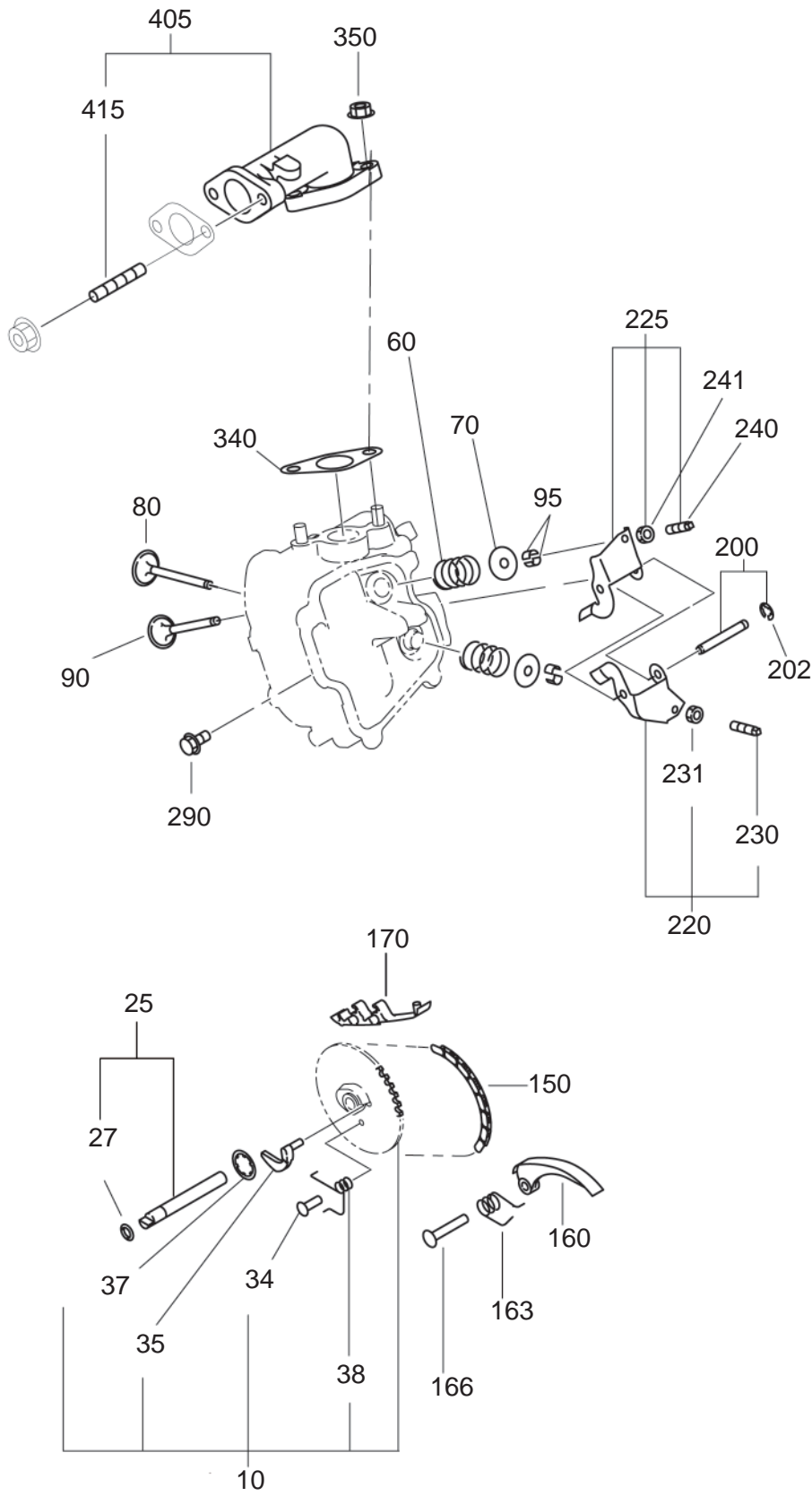



# SECTION 3 INTAKE and EXHAUST GROUP

FIG. 315

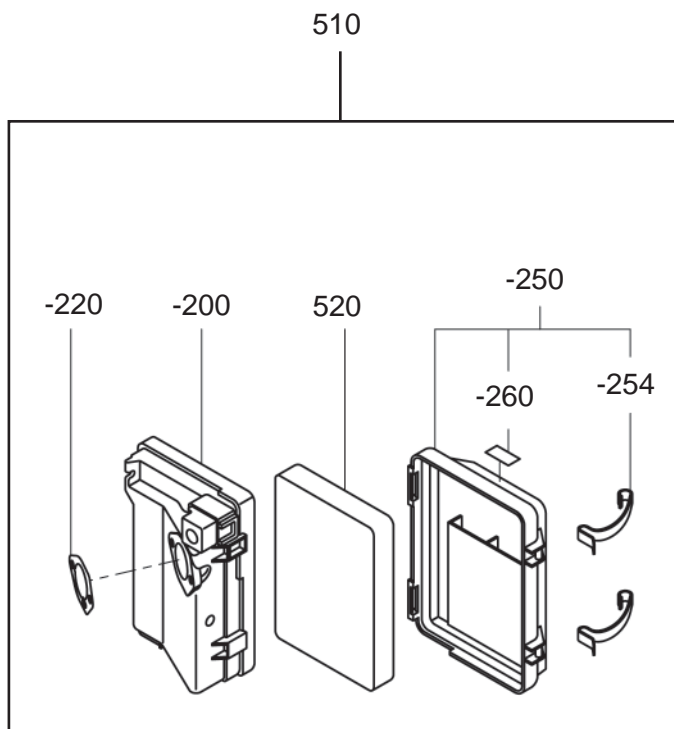
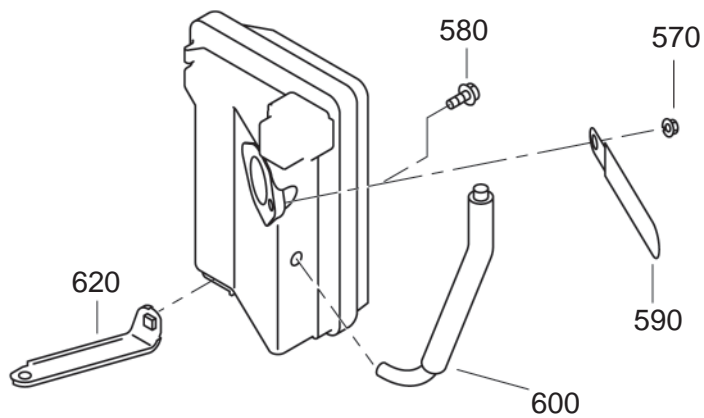



SECTION 4 GOVERNOR GROUP

FIG. 400

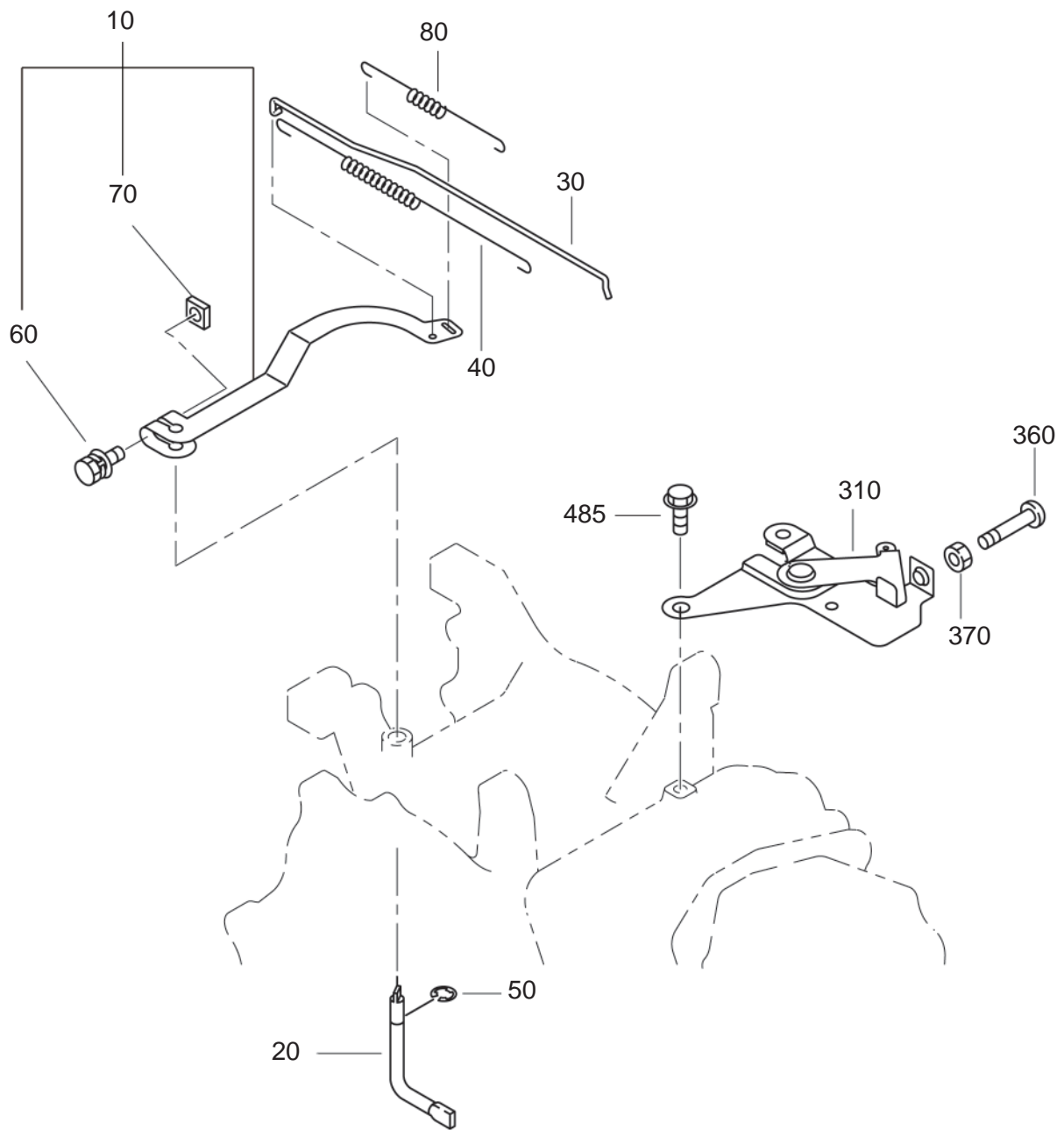







SECTION 6 FUEL, LUBRICATION GROUP

FIG. 600

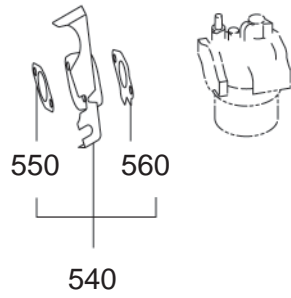



SECTION 6 FUEL, LUBRICATION GROUP

FIG. 640

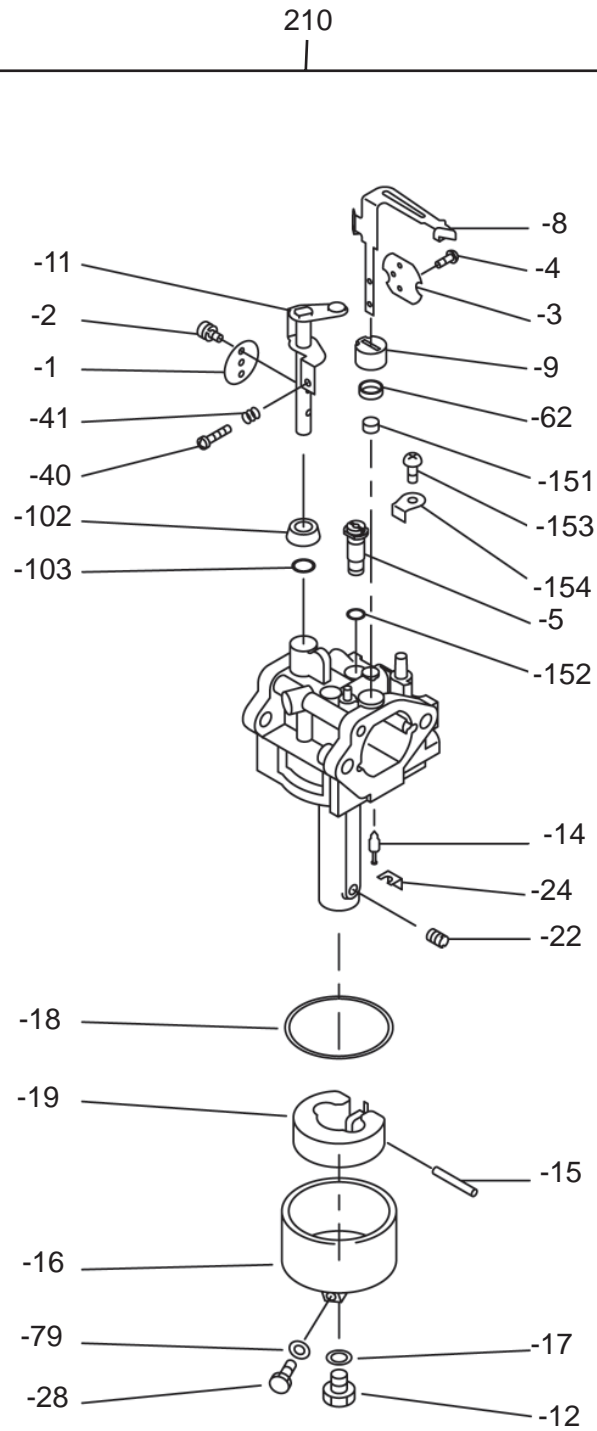



SECTION 7 ELECTRIC DEVICE GROUP

FIG. 700

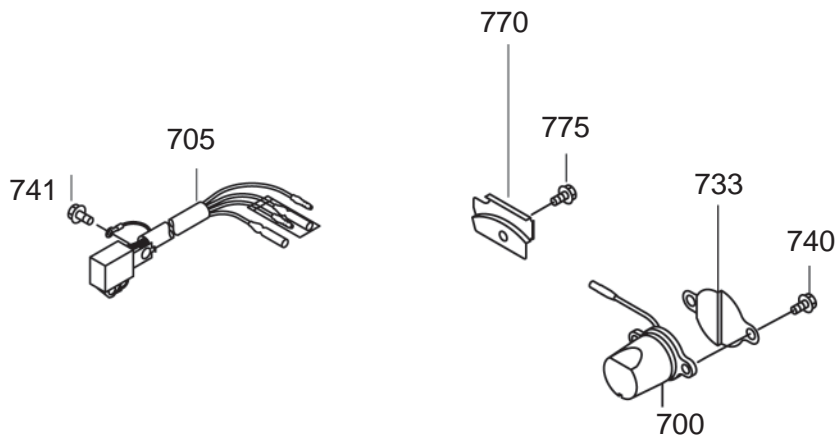
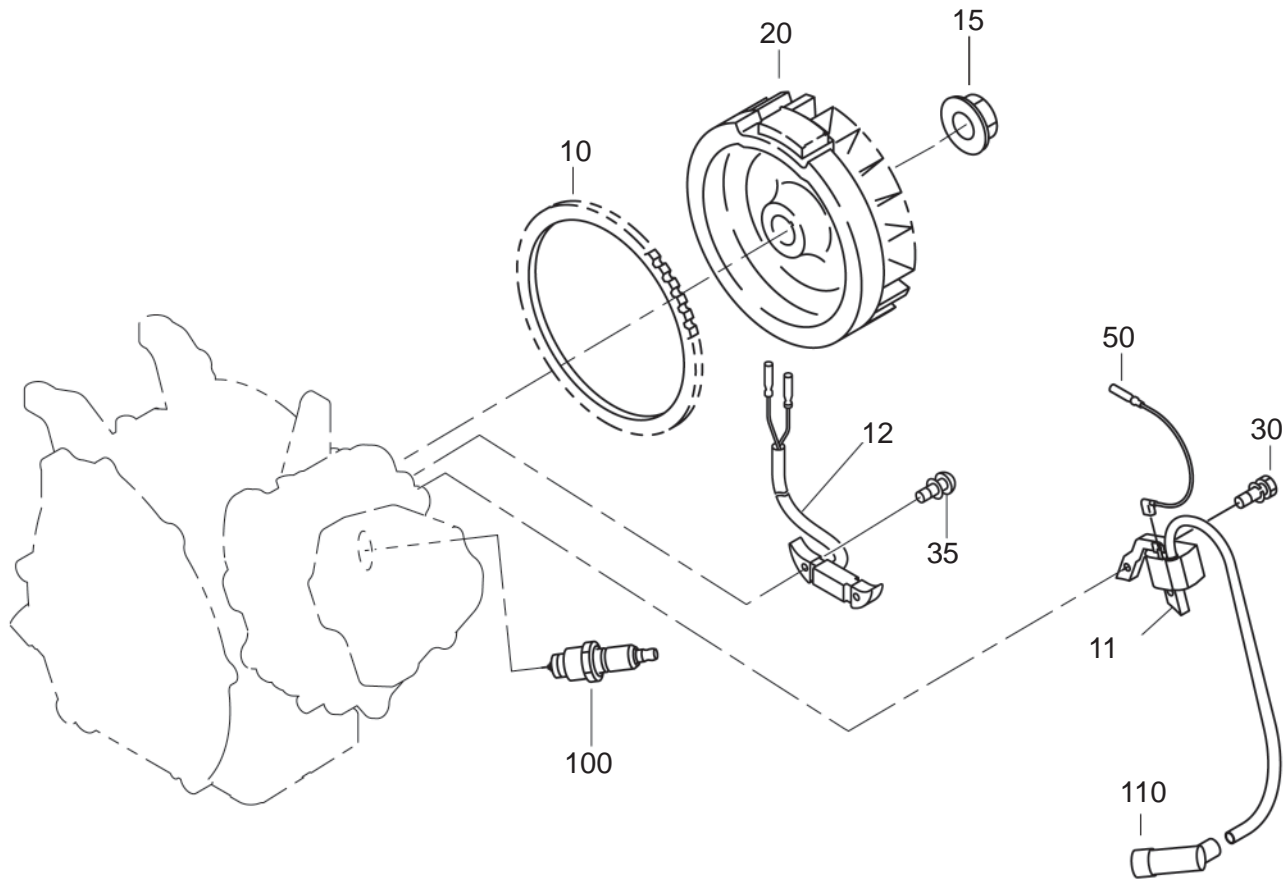



SECTION 7 ELECTRIC DEVICE GROUP

FIG. 730

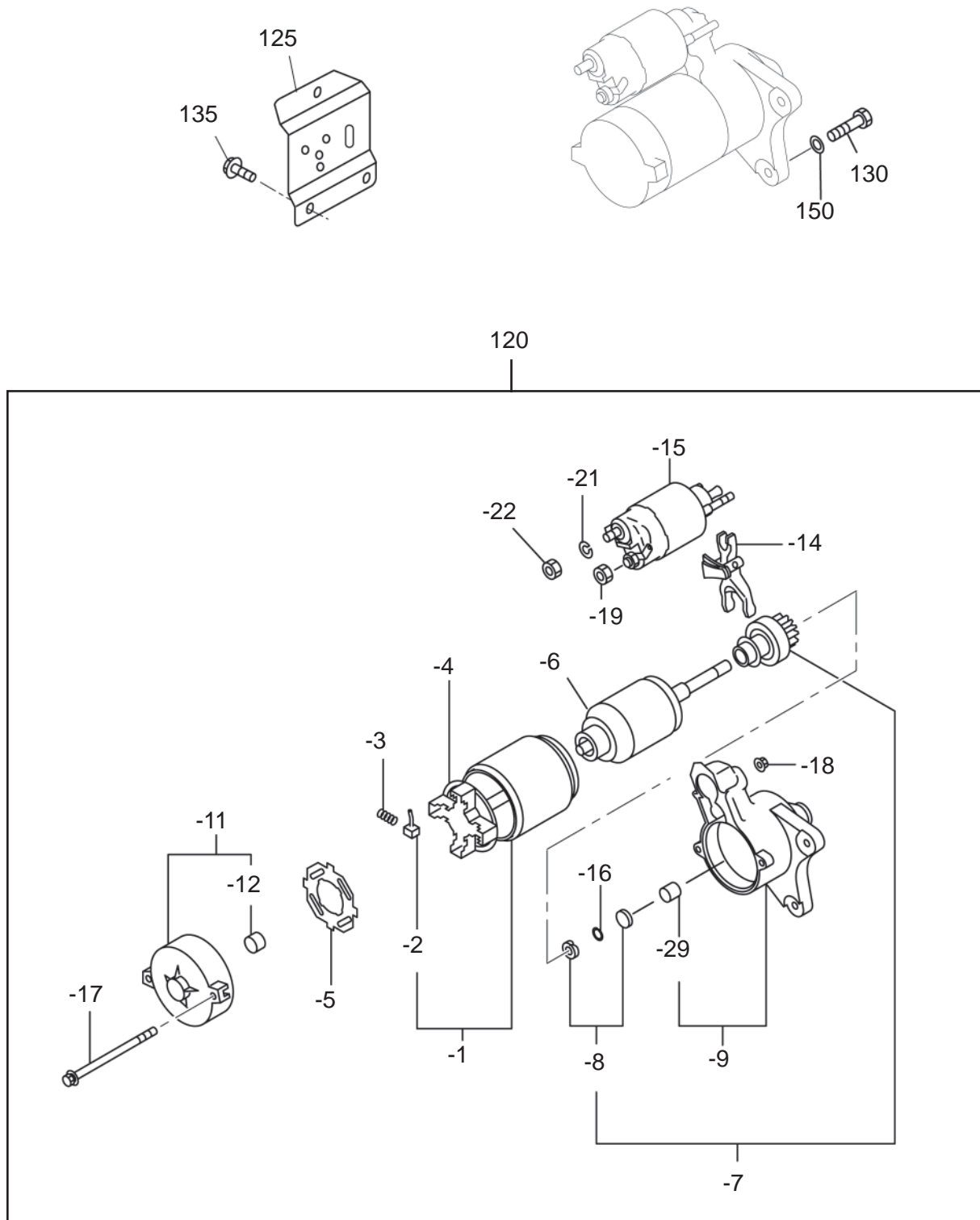



SECTION 7 ELECTRIC DEVICE GROUP

FIG. 740

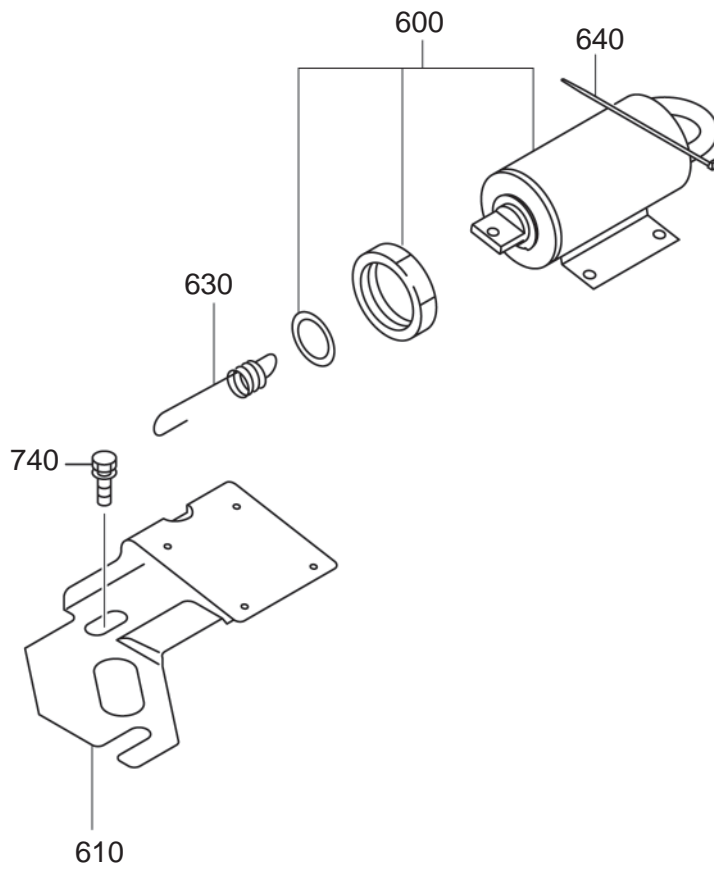



SECTION 21 ENGINE GROUP

FIG. 2130

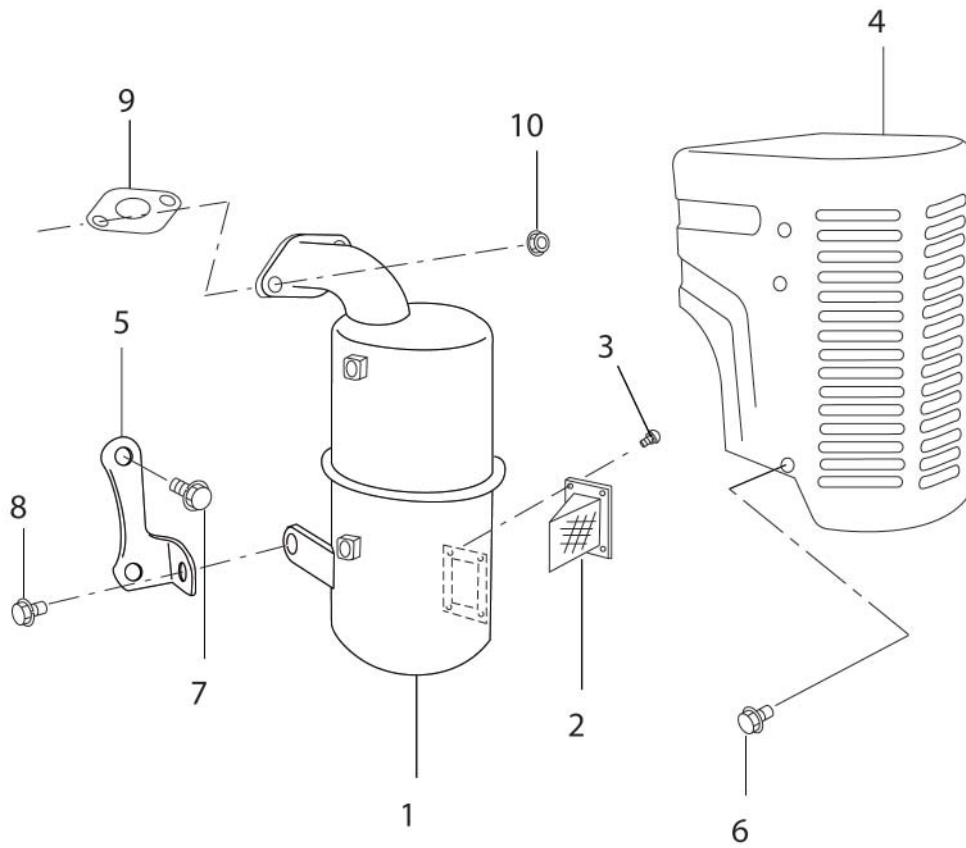



SECTION 22 GENERATOR GROUP

FIG. 2200

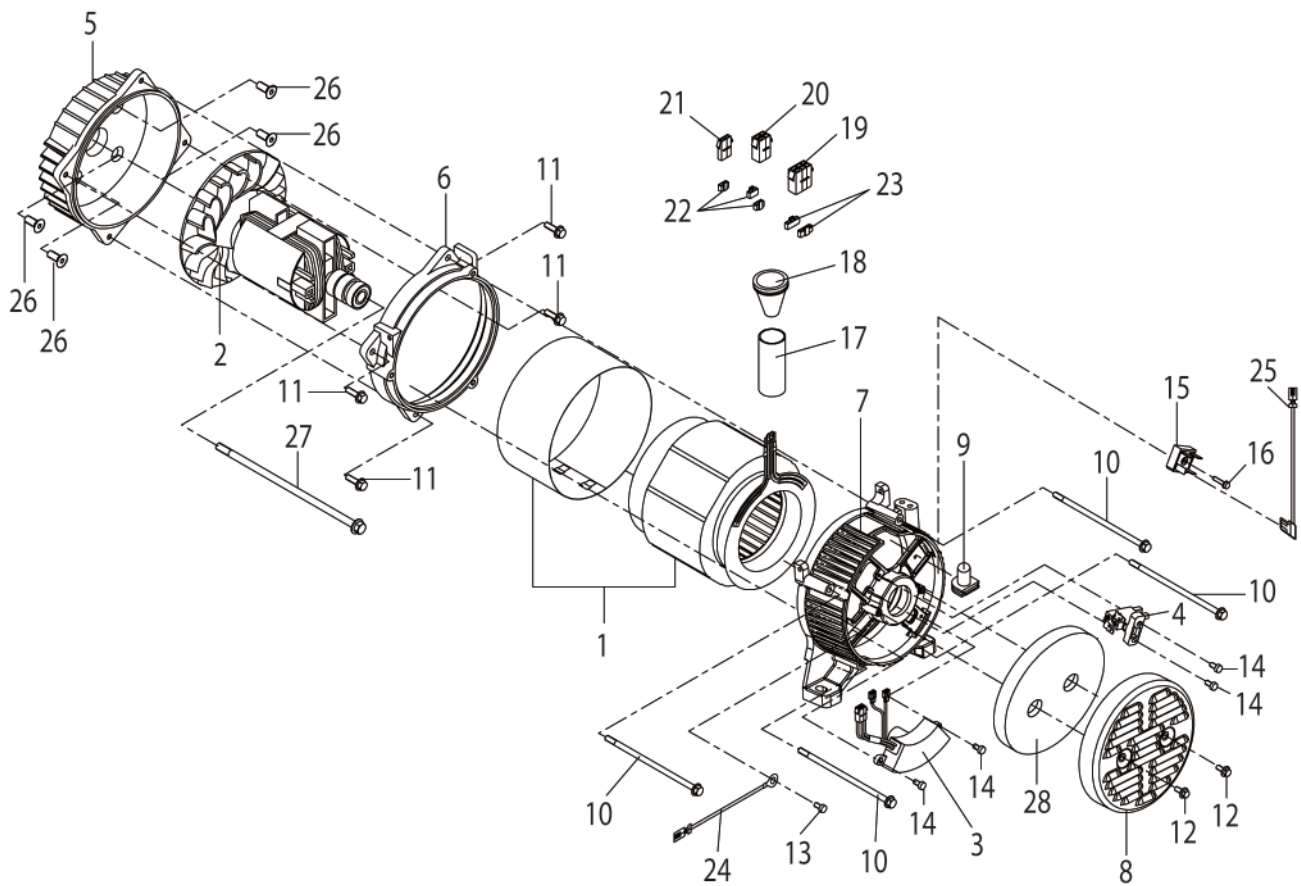



SECTION 23 BASE, FRAME GROUP

FIG. 2300

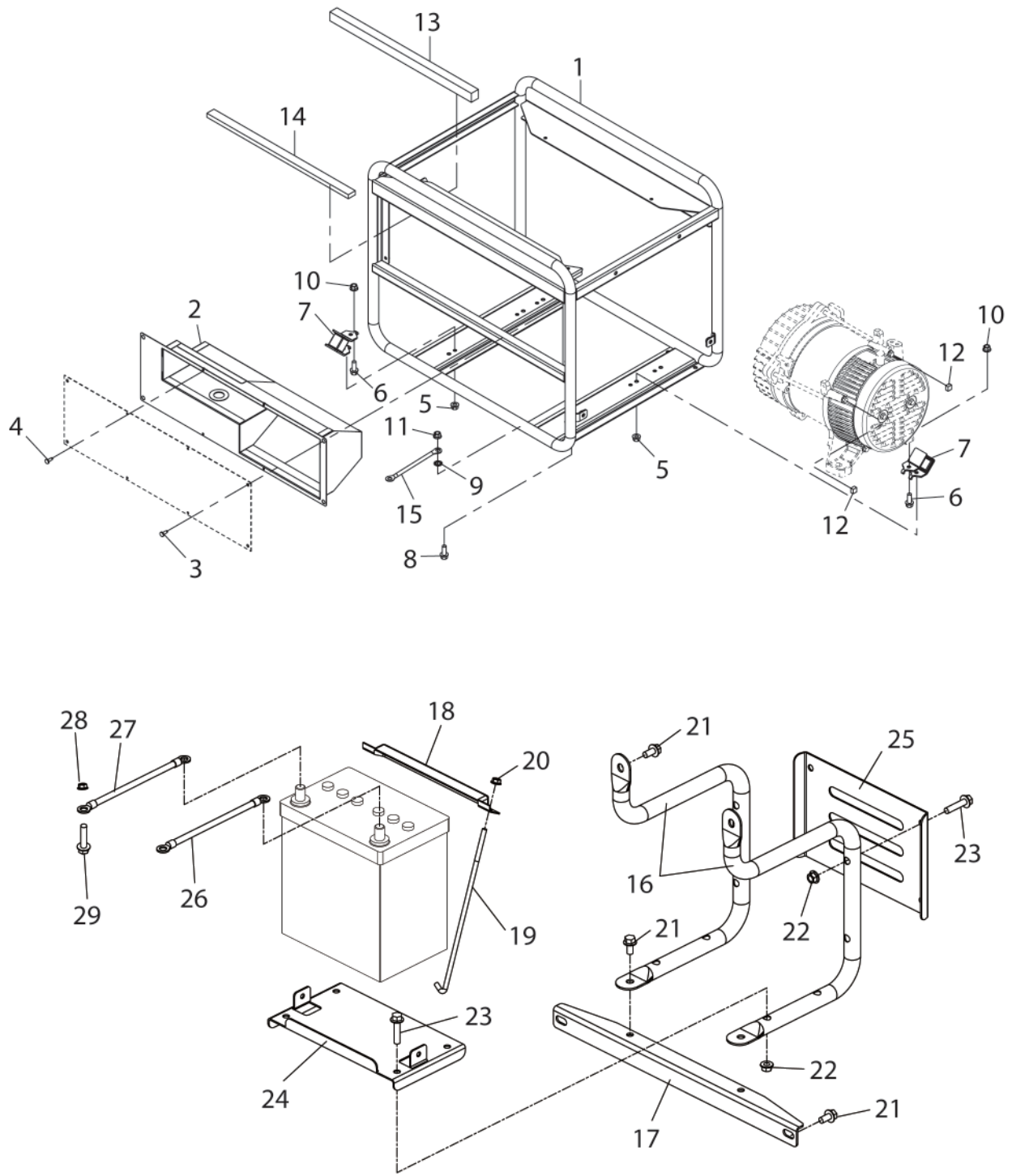



# SECTION 24 CONTROL GROUP - RECOIL

FIG.2400

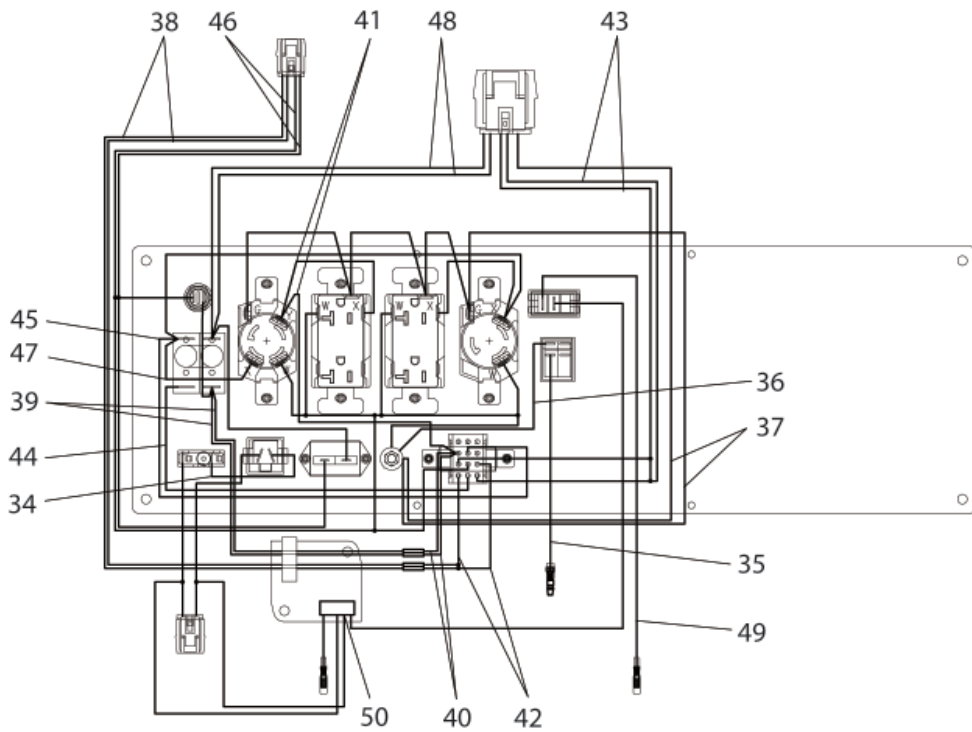
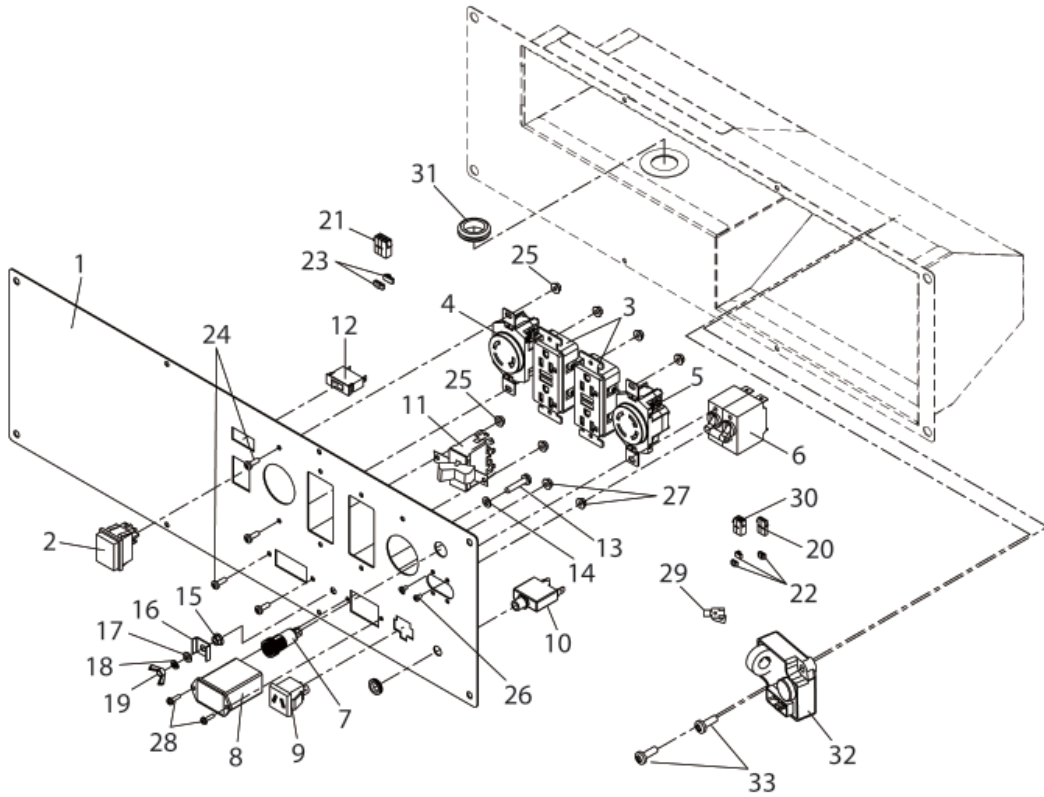

## SECTION 24      CONTROL GROUP - RECOIL

REF.	PART NO.	DESCRIPTION	QTY.	REMARKS	FROM-TO	FIG.
1	36C-41002-08	Control Panel Cp	1			2400
2	36A-49000-08	Switch, engine	1			2400
3	36A-47002-08	AC Concent	2	GFCI		2400
4	36B-47000-08	AC Concent	1	L5-30		2400
5	36B-47001-08	AC Concent	1	L14-30		2400
6	36C-48001-08	Circuit Breaker	1	20A		2400
7	36A-49003-08	Pilot Lamp	1			2400
8	36A-49002-08	Hour Meter	1			2400
9	36A-47101-08	DC Concent	1			2400
10	36A-48001-08	Circuit Breaker	1	10A		2400
11	36B-49000-08	Switch, v select	1			2400
12	36B-49001-08	Switch, i/c	1			2400
13	36A-80102-08	Screw and Washer Ay	1			2400
14	36A-82000-08	Lock Washer	1			2400
15	36A-81000-08	Flange Nut	1			2400
16	36A-82100-08	Cap Washer	1			2400
17	36A-82200-08	Washer	1			2400
18	36A-82300-08	Spring Washer	1			2400
19	36A-81100-08	Wing Nut	1			2400
20	36A-70003-08	Connector	1	2 p		2400
21	36A-70001-08	Connector	1	6 p		2400
22	36A-70101-08	Retainer	3	2 p		2400
23	36A-70100-08	Retainer	2	3 p		2400
24	36A-80202-08	Screw	10			2400
25	36A-81001-08	Flange Nut	10			2400
26	36A-80103-08	Screw and Washer Ay	4			2400
27	36A-81005-08	Flange Nut	2			2400
28	36A-80203-08	Screw	2			2400
29	36A-70300-08	Terminal	1			2400
30	36A-70007-08	Connector	1	4 p		2400
31	36C-49900-08	Grommet	1			2400
32	KU3-11015-01	Idle C/U Cp	1	150V		2400
33	36A-80204-08	Screw	2			2400
34	36A-71003-08	Wire	1	white		2400
35	36A-71006-08	Wire	1	black		2400
36	36A-71036-08	Wire	1	green		2400
37	36A-71037-08	Wire	1	green		2400
38	36A-71029-08	Wire	2	orange		2400
39	36A-71038-08	Wire	1	red		2400
40	36A-71039-08	Wire	1	red		2400
41	36A-71040-08	Wire	1	red		2400
42	36A-71041-08	Wire	1	orange		2400
43	36A-71042-08	Wire	1	blue		2400
44	36A-71043-08	Wire	1	blue		2400
45	36A-71044-08	Wire	1	blue		2400
46	36A-71045-08	Wire	1	gray		2400

# SECTION 24 CONTROL GROUP - RECOIL

FIG.2400

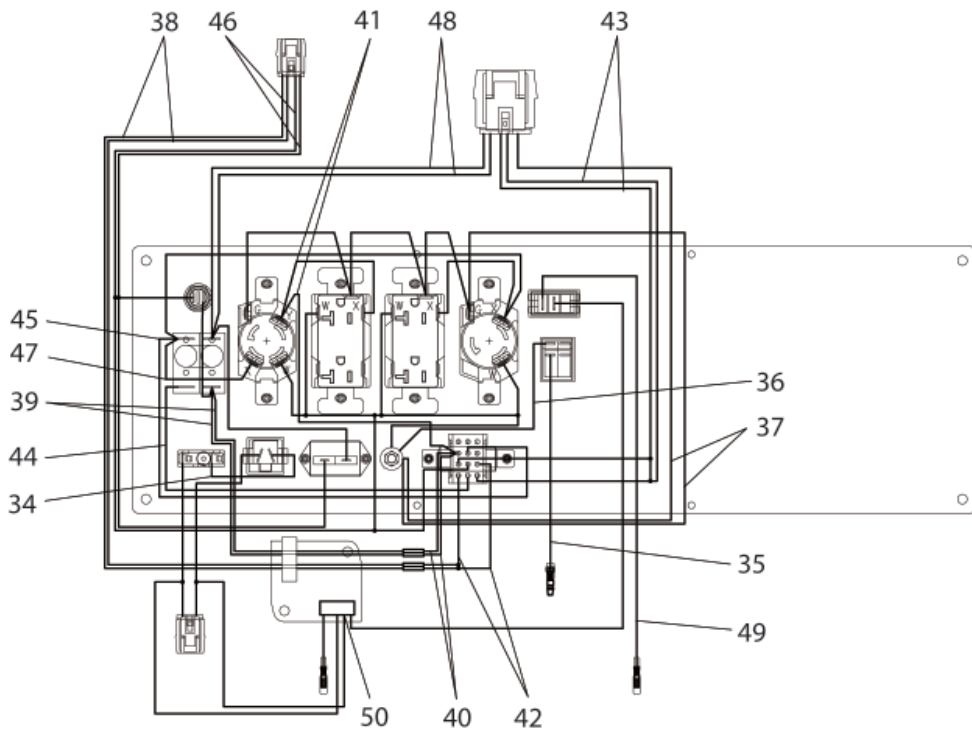
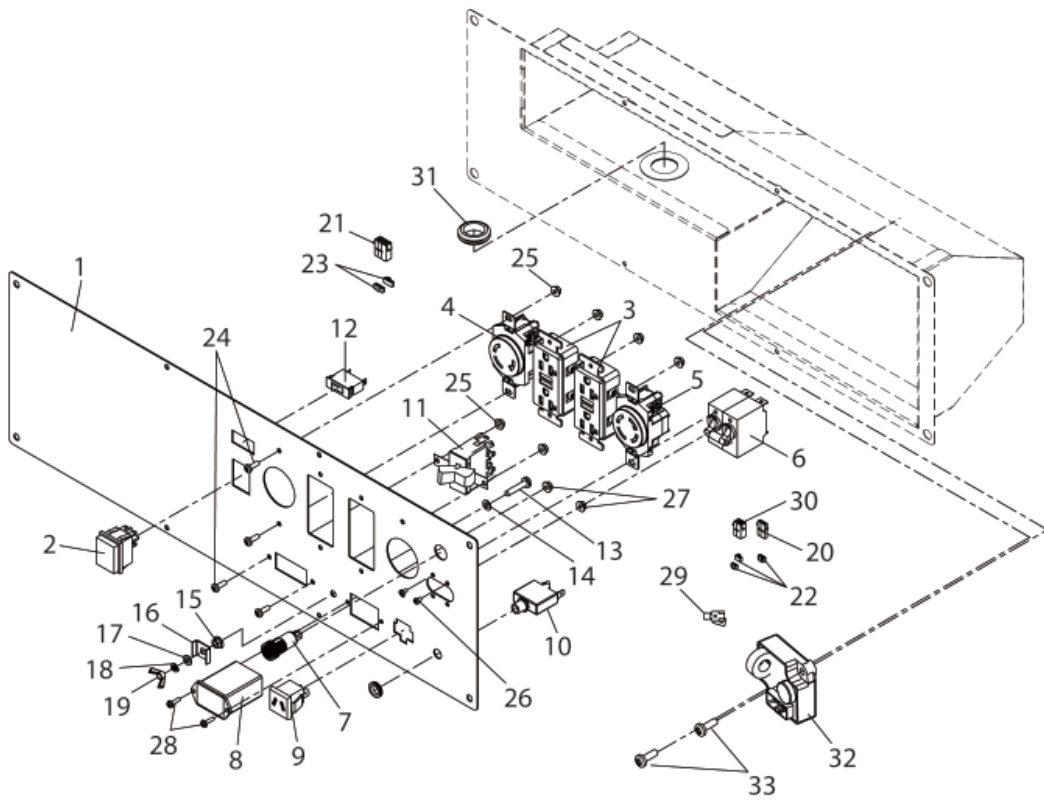



# SECTION 24 CONTROL GROUP - ELECTRIC START

FIG.2400

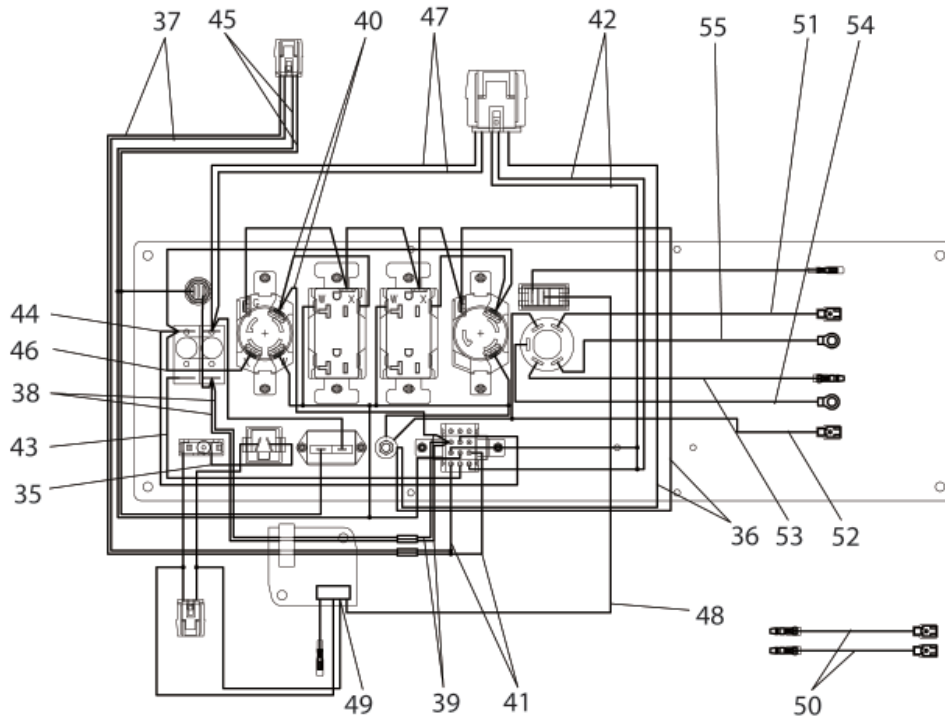
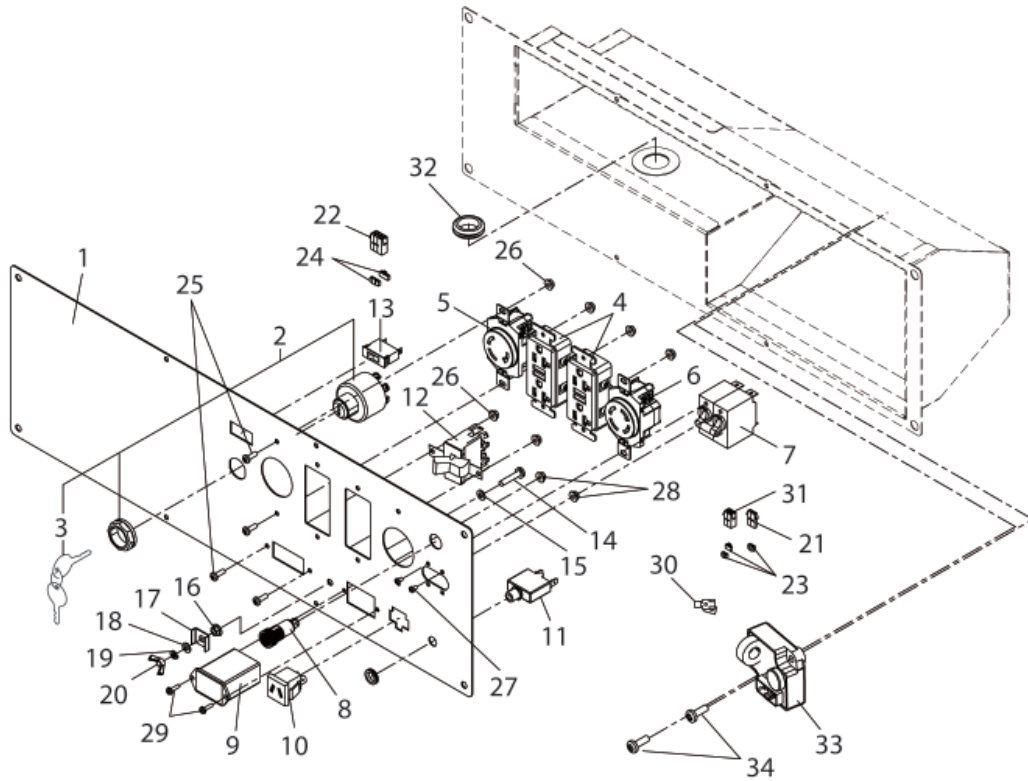

## SECTION 24      CONTROL GROUP - ELECTRIC START

REF.	PART NO.	DESCRIPTION	QTY.	REMARKS	FROM-TO	FIG.
1	36C-41003-08	Control Panel Cp	1			2400
2	066-00003-30	Switch, engine	1			2400
3	066-00099-80	Key, switch	2			2400
4	36A-47002-08	AC Concent	2	GFCI		2400
5	36B-47000-08	AC Concent	1	3 p		2400
6	36B-47001-08	AC Concent	1	4 p		2400
7	36C-48001-08	Circuit Breaker	1	20A		2400
8	36A-49003-08	Pilot Lamp	1			2400
9	36A-49002-08	Hour Meter	1			2400
10	36A-47101-08	DC Concent	1			2400
11	36A-48001-08	Circuit Breaker	1	10A		2400
12	36B-49000-08	Switch, v select	1			2400
13	36B-49001-08	Switch, i/c	1			2400
14	36A-80102-08	Screw and Washer Ay	1			2400
15	36A-82000-08	Lock Washer	1			2400
16	36A-81000-08	Flange Nut	1			2400
17	36A-82100-08	Cap Washer	1			2400
18	36A-82200-08	Washer	1			2400
19	36A-82300-08	Spring Washer	1			2400
20	36A-81100-08	Wing Nut	1			2400
21	36A-70003-08	Connector	1	2 p		2400
22	36A-70001-08	Connector	1	6 p		2400
23	36A-70101-08	Retainer	3	2 p		2400
24	36A-70100-08	Retainer	2	3 p		2400
25	36A-80202-08	Screw	10			2400
26	36A-81001-08	Flange Nut	10			2400
27	36A-80103-08	Screw and Washer Ay	4			2400
28	36A-81005-08	Flange Nut	2			2400
29	36A-80203-08	Screw	2			2400
30	36A-70300-08	Terminal	1			2400
31	36A-70007-08	Connector	1	4 p		2400
32	36C-49900-08	Grommet	1			2400
33	KU3-11015-01	Idle C/U Cp	1	150V		2400
34	36A-80204-08	Screw	2			2400
35	36A-71003-08	Wire	1	white		2400
36	36A-71037-08	Wire	1	green		2400
37	36A-71029-08	Wire	2	orange		2400
38	36A-71038-08	Wire	1	red		2400
39	36A-71039-08	Wire	1	red		2400
40	36A-71040-08	Wire	1	red		2400
41	36A-71041-08	Wire	1	orange		2400
42	36A-71042-08	Wire	1	blue		2400
43	36A-71043-08	Wire	1	blue		2400
44	36A-71044-08	Wire	1	blue		2400
45	36A-71045-08	Wire	1	gray		2400
46	36A-71046-08	Wire	1	blue		2400

# SECTION 24 CONTROL GROUP - ELECTRIC START

FIG.2400

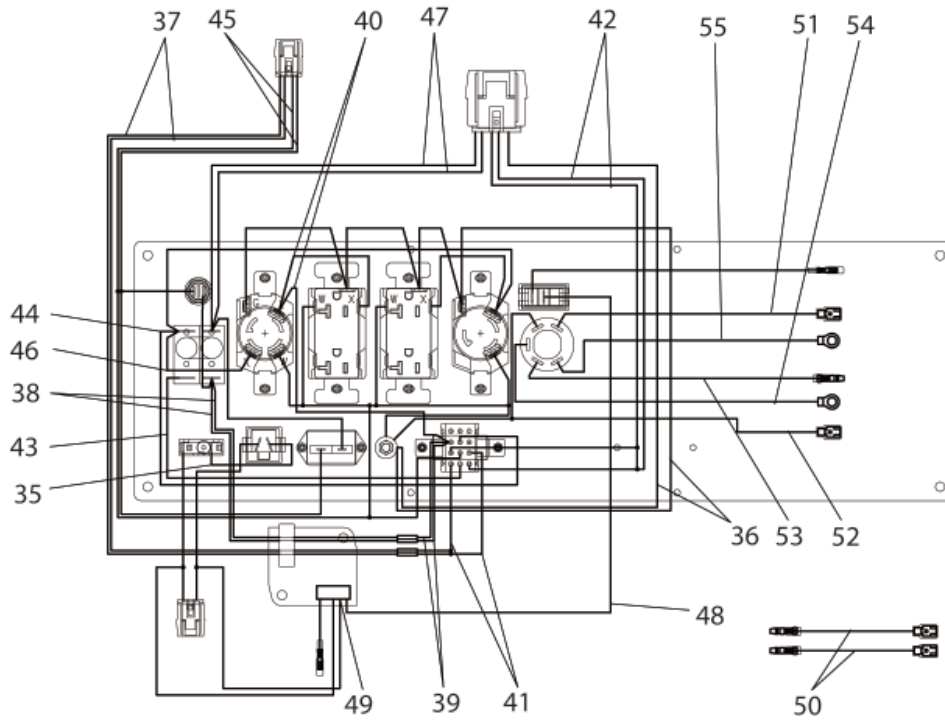
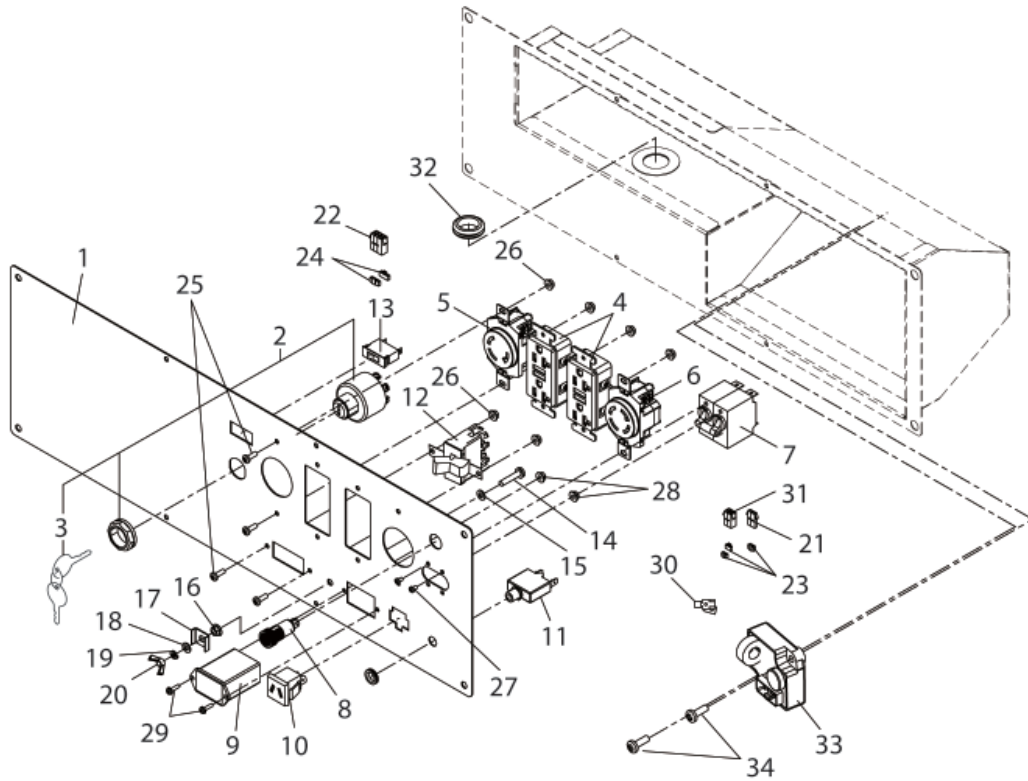



SECTION 26 FUEL TANK GROUP

FIG.2600

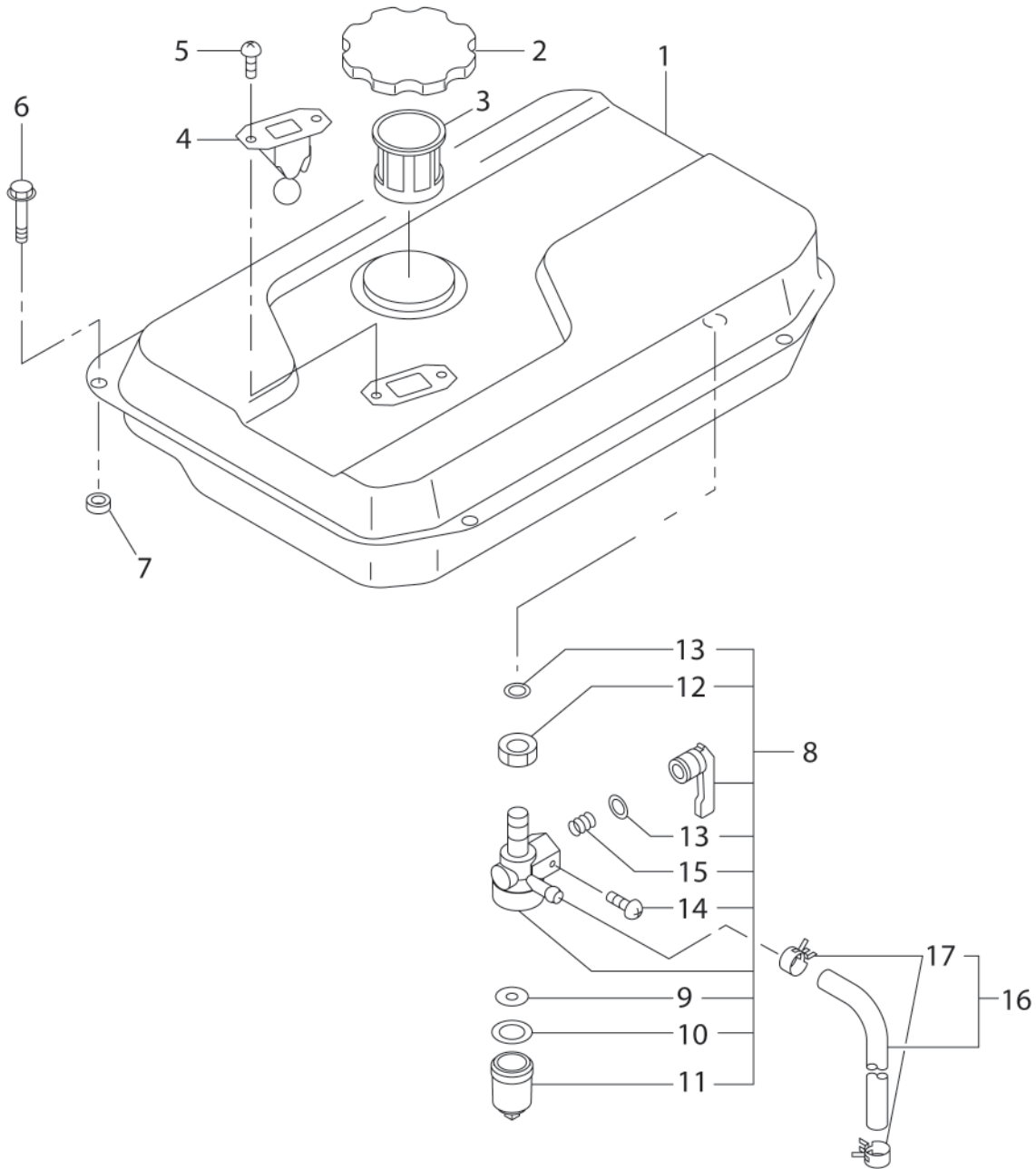



SECTION 29 ACCESSORY GROUP

FIG.2900

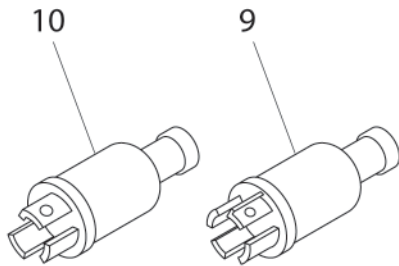
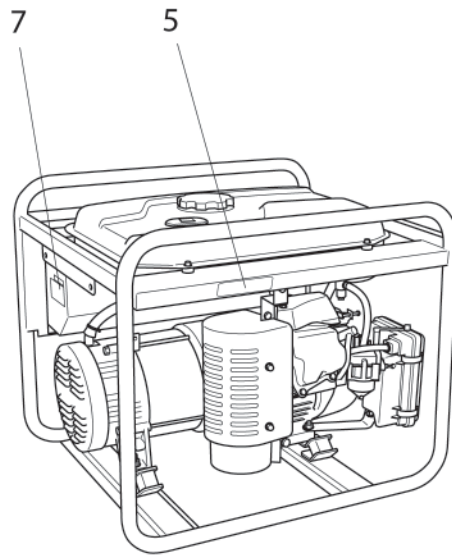
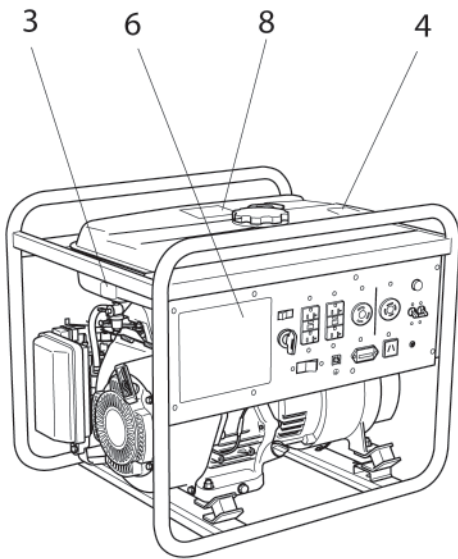
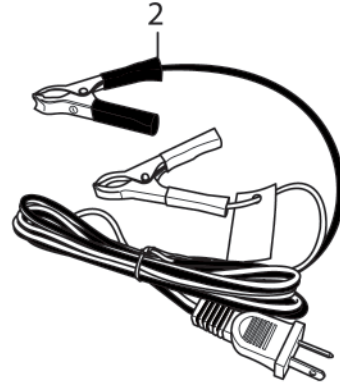
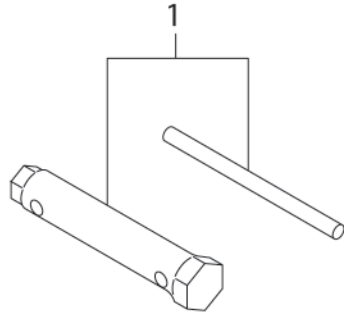



PRINTED IN THE USA