

Roland

FR-18 diatonic



Owner's Manual

WARNING – To reduce the risk of fire or electric shock, do not expose this device to rain or moisture.

For EU countries



This product complies with the requirements of European Directive EMC 2004/108/EC.
Dieses Produkt entspricht der europäischen Richtlinie EMC 2004/108/EC.
Ce produit est conforme aux exigences de la directive européenne EMC 2004/108/EC.
Questo prodotto è conforme alle esigenze della direttiva europea EMC 2004/108/EC.
Este producto cumple con la directrice EMC 2004/108/EC de la CE.
Dit product beantwoordt aan de richtlijn EMC 2004/108/EC van de Europese Unie.

For the USA

FEDERAL COMMUNICATIONS COMMISSION RADIO FREQUENCY INTERFERENCE STATEMENT

This equipment has been tested and found to comply with the limits for a Class B digital device, pursuant to Part 15 of the FCC Rules. These limits are designed to provide reasonable protection against harmful interference in a residential installation. This equipment generates, uses, and can radiate radio frequency energy and, if not installed and used in accordance with the instructions, may cause harmful interference to radio communications. However, there is no guarantee that interference will not occur in a particular installation. If this equipment does cause harmful interference to radio or television reception, which can be determined by turning the equipment off and on, the user is encouraged to try to correct the interference by one or more of the following measures:

- Reorient or relocate the receiving antenna.
- Increase the separation between the equipment and receiver.
- Connect the equipment into an outlet on a circuit different from that to which the receiver is connected.
- Consult the dealer or an experienced radio/TV technician for help.

This device complies with Part 15 of the FCC Rules. Operation is subject to the following two conditions:

- (1) This device may not cause harmful interference, and
- (2) This device must accept any interference received, including interference that may cause undesired operation.

Unauthorized changes or modification to this system can void the users authority to operate this equipment.
This equipment requires shielded interface cables in order to meet FCC class B Limit.

For Canada

NOTICE

This Class B digital apparatus meets all requirements of the Canadian Interference-Causing Equipment Regulations.

AVIS

Cet appareil numérique de la classe B respecte toutes les exigences du Règlement sur le matériel brouilleur du Canada.

For the UK

IMPORTANT: THE WIRES IN THIS MAINS LEAD ARE COLOURED IN ACCORDANCE WITH THE FOLLOWING CODE.

BLUE: NEUTRAL
BROWN: LIVE

As the colours of the wires in the mains lead of this apparatus may not correspond with the coloured markings identifying the terminals in your plug, proceed as follows:

The wire which is coloured BLUE must be connected to the terminal which is marked with the letter N or coloured BLACK.
The wire which is coloured BROWN must be connected to the terminal which is marked with the letter L or coloured RED.
Under no circumstances must either of the above wires be connected to the earth terminal of a three pin plug.

For the USA

DECLARATION OF CONFORMITY Compliance Information Statement

Model Name : V-Accordion FR-18 diatonic
Type of Equipment : Digital accordion
Responsible Party : Roland Corporation U.S.
Address : 5100 S. Eastern Avenue, Los Angeles, CA 90040-2938
Telephone : (323) 890-3700

The technology used in the FR-18 diatonic is covered by U.S. Patent No. 6.946.594.

Roland

FR-18 diatonic

Owner's Manual

Thank you and congratulations on your choice of the Roland FR-18 diatonic V-Accordion.

The FR-18 diatonic is an amazingly versatile electronic instrument that can emulate the sounds of a vast array of diatonic accordions. Its major advantage is that it allows you to change sounds, keyboard layouts (tablatures) and key note without changing instruments. Apart from the financial benefit, this also means that you can use your familiar playing style and techniques while covering a host of different musical genres.

To ensure that you obtain the maximum enjoyment and take full advantage of your FR-18 diatonic, please read this owner's manual carefully.

About this manual

You should first read the chapter "Before you start playing" on p. 15. It explains how to connect the AC adaptor or install batteries and turn on the power. This owner's manual explains everything, from the basic functions of the FR-18 diatonic to more advanced functions.

Conventions in this manual

In order to explain the operations as clearly as possible, this manual uses the following conventions:

- Text enclosed in square brackets [] indicates the name of a button or knob. Example: the [USER PROG.] button.
- Paragraphs that begin with "NOTE" are cautionary statements that you must read.
- The numbers of pages that you can turn to for additional or related information are given like this: (p. **).

Before using this instrument, carefully read "USING THE UNIT SAFELY" on p. 5 and "Important notes" on p. 9. Those sections provide information concerning the proper operation of the FR-18 diatonic. Additionally, in order to feel assured that you have gained a good grasp of every feature provided by your new unit, the manual should be read in its entirety. The manual should be saved and kept on hand as a convenient reference.

1. Features

Adjustable keyboard layout (tablature) and key note

The FR-18 diatonic grants you the possibility to easily configure your favorite keyboard layout. You can choose from among 12 factory tablatures.

Changing the instrument's tonality is also possible, so that you can play in any key with your FR-18 diatonic. There are 12 different musical keys that can be selected at the press of a button.

Super realistic accordion simulations

The FR-18 diatonic contains sounds that were obtained by sampling popular traditional acoustic diatonic accordions. This diatonic V-Accordion allows you to switch from a traditional Italian "Organetto" to a typical "Tex-Mex" sound without changing instruments, for instance.

Different tuning systems and scales are also available.

Orchestral sounds

8 orchestral sounds are available and can be used in combination with traditional diatonic accordion sounds—complete with full bellows articulation, and unique keyboard modes (Solo, Dual).

In addition, the FR-18 diatonic provides 3 orchestral bass and orchestral chord sounds for the bass and chord sections.

Virtual Tone Wheel organ sounds

The FR-18 diatonic allows you to play amazing organ parts in almost the same way as an organ player using the treble section. Every organ sound features a Rotary effect (both slow and fast).

Drum sounds

You can also use the FR-18 diatonic to play simple drum parts with your left hand (bass and chord sections).

Sound expansion

The FR-18 diatonic provides two internal memory banks that allow you to add new sounds.

PBM (Physical Behavior Modeling)

The FR-18 diatonic is based on Roland's sound generation technology called "PBM" (Physical Behavior Modeling) whose sonic result is very close to the sound of traditional diatonic accordions.

The digital advantage

The FR-18 diatonic includes all functions and sounds of a traditional diatonic instrument, thus conveying a truly natural feel and sound. Yet it also provides the advantages only an electronic musical instrument can give you:

- you can play using any desired keyboard layout (tablature) and in any key.

- possibility to choose among a variety of sounds.
- you can play with headphones, i.e. without disturbing your neighbors or family.
- tuning stability over time and wear resistance of all mechanical parts.
- reduced overall weight.

Superb performance flexibility

The FR-18 diatonic allows you to control external MIDI-compatible instruments. The treble buttons are velocity-sensitive, while the bellows controller provides more articulation possibilities than any other MIDI keyboard, MIDI wind instrument, etc., you may know.

Sophisticated bellows response

You will love the instrument's fast response, high sensitivity and detection accuracy of opening/closing movements of the bellows, which have become possible thanks to a new bellows pressure sensing circuitry.

A bellows resistance regulator knob allows you to adjust the bellows' inertia to your preference.

Save your settings (User Programs) to a USB memory

You can save your settings (User Programs) by connecting an optional USB memory to the FR-18 diatonic's USB port, allowing you to use them on another FR-18 diatonic, or to share your settings with other FR-18 diatonic users.

Useful accessory

The FR-18 diatonic has a compartment for optional rechargeable Ni-MH (AA-type) batteries, so that you don't need to connect it to a wall outlet. Consider purchasing such batteries (you will need 8) when performing on stage.

USING THE UNIT SAFELY

INSTRUCTIONS FOR THE PREVENTION OF FIRE, ELECTRIC SHOCK, OR INJURY TO PERSONS

About **WARNING** and **CAUTION** Notices

WARNING	Used for instructions intended to alert the user to the risk of death or severe injury should the unit be used improperly.
CAUTION	Used for instructions intended to alert the user to the risk of injury or material damage should the unit be used improperly. * Material damage refers to damage or other adverse effects caused with respect to the home and all its furnishings, as well to domestic animals or pets.

About the Symbols

	The symbol alerts the user to important instructions or warnings. The specific meaning of the symbol is determined by the design contained within the triangle. In the case of the symbol at left, it is used for general cautions, warnings, or alerts to danger.
	The symbol alerts the user to items that must never be carried out (are forbidden). The specific thing that must not be done is indicated by the design contained within the circle. In the case of the symbol at left, it means that the unit must never be disassembled.
	The symbol alerts the user to things that must be carried out. The specific thing that must be done is indicated by the design contained within the circle. In the case of the symbol at left, it means that the power-cord plug must be unplugged from the outlet.

ALWAYS OBSERVE THE FOLLOWING

WARNING

- Do not open (or modify in any way) the unit or its AC adaptor.

- Do not attempt to repair the unit, or replace parts within it (except when this manual provides specific instructions directing you to do so). Refer all servicing to your retailer, the nearest Roland Service Center, or an authorized Roland distributor, as listed on the "Information" page.

- Never install the unit in any of the following locations.
 - Subject to temperature extremes (e.g., direct sunlight in an enclosed vehicle, near a heating duct, on top of heat-generating equipment); or are
 - Damp (e.g., baths, washrooms, on wet floors); or are
 - Exposed to steam or smoke; or are
 - Subject to salt exposure; or are
 - Humid; or are
 - Exposed to rain; or are
 - Dusty or sandy; or are
 - Subject to high levels of vibration and shakiness.

- Make sure you always have the FR-18 diatonic placed so it is level and sure to remain stable. Never place it on stands that could wobble, or on inclined surfaces.

- Be sure to use only the AC adaptor supplied with the unit. Also, make sure the line voltage at the installation matches the input voltage specified on the AC adaptor's body. Other AC adaptors may use a different polarity, or be designed for a different voltage, so their use could result in damage, malfunction, or electric shock.

- Use only the supplied power-supply cord. Also, the supplied power cord must not be used with any other device.

- Do not excessively twist or bend the power cord, or place heavy objects on it. Doing so can damage the cord, producing severed elements and short circuits. Damaged cords are fire and shock hazards!

WARNING

- The FR-18 diatonic, either alone or in combination with an amplifier and headphones or speakers, may be capable of producing sound levels that could cause permanent hearing loss. Do not operate for a long period of time at a high volume level, or at a level that is uncomfortable. If you experience any hearing loss or ringing in the ears, you should immediately stop using the unit, and consult an audiologist.

- Do not allow any objects (e.g., flammable material, coins, pins); or liquids of any kind (water, soft drinks, etc.) to penetrate the FR-18 diatonic.

- Immediately turn the power off, remove the AC adaptor from the outlet, and request servicing by your retailer, the nearest Roland Service Center, or an authorized Roland distributor, as listed on the "Information" page when:
 - The AC adaptor, the power-supply cord, or the plug has been damaged; or
 - If smoke or unusual odor occurs
 - Objects have fallen into, or liquid has been spilled onto the unit; or
 - The unit has been exposed to rain (or otherwise has become wet); or
 - The unit does not appear to operate normally or exhibits a marked change in performance.



- In households with small children, an adult should provide supervision until the child is capable of following all the rules essential for the safe operation of the FR-18 diatonic.

- Protect the FR-18 diatonic from strong impact. (Do not drop it!)

⚠ WARNING

- Do not force the FR-18 diatonic's power-supply cord to share an outlet with an unreasonable number of other devices. Be especially careful when using extension cords—the total power used by all devices you have connected to the extension cord's outlet must never exceed the power rating (watts/amperes) for the extension cord. Excessive loads can cause the insulation on the cord to heat up and eventually melt through. 

- Before using the FR-18 diatonic in a foreign country, consult with your retailer, the nearest Roland Service Center, or an authorized Roland distributor, as listed on the "Information" page. 

- Batteries must never be heated, taken apart, or thrown into fire or water. 



- Never expose batteries to excessive heat such as sunshine, fire or the like. 

- Incorrect handling of batteries, rechargeable batteries, or battery charger can cause leakage, overheating, fire, or explosion. Before use, you must read and strictly observe all of the precautions that accompany the batteries, rechargeable batteries, or battery charger. 
When using rechargeable batteries and a charger, use only the combination of rechargeable batteries and charger specified by battery manufacturer.

⚠ CAUTION

- The unit and the AC adaptor should be located so its location or position does not interfere with their proper ventilation. 

- Always grasp only the plug on the AC adaptor cord when plugging into, or unplugging from, an outlet or this unit. 

- At regular intervals, you should unplug the AC adaptor and clean it by using a dry cloth to wipe all dust and other accumulations away from its prongs. Also, disconnect the power plug from the power outlet whenever the unit is to remain unused for an extended period of time. Any accumulation of dust between the power plug and the power outlet can result in poor insulation and lead to fire. 

- Try to prevent cords and cables from becoming entangled. Also, all cords and cables should be placed so they are out of the reach of children. 

- Never climb on top of, or place heavy objects on the unit. 

- Never handle the AC adaptor or its plugs with wet hands when plugging into, or unplugging from, an outlet or this unit. 

- Before moving the unit, disconnect the AC adaptor and all cords coming from external devices. 

⚠ CAUTION

- Before cleaning the unit, turn off the power and unplug the AC adaptor from the outlet (see p. 15). 

- Whenever you suspect the possibility of lightning in your area, disconnect the AC adaptor from the outlet. 

- If used improperly, batteries may explode or leak and cause damage or injury. In the interest of safety, please read and observe the following precautions. 

- Carefully follow the installation instructions for batteries, and make sure you observe the correct polarity. 

- Avoid using new batteries together with used ones. In addition, avoid mixing different types of batteries. 

- Remove the batteries whenever the unit is to remain unused for an extended period of time.

- If a battery has leaked, use a soft piece of cloth or paper towel to wipe all remnants of the discharge from the battery compartment. Then install new batteries. To avoid inflammation of the skin, make sure that none of the battery discharge gets onto your hands or skin. Exercise the utmost caution so that none of the discharge gets near your eyes. Immediately rinse the affected area with running water if any of the discharge has entered the eyes.

- Never keep batteries together with metallic objects such as ball-point pens, necklaces, hairpins, etc.

- Used batteries must be disposed of in compliance with whatever regulations for their safe disposal that may be observed in the region in which you live. 

- Keep any button caps and screws you may remove in a safe place out of children's reach, so there is no chance of them being swallowed accidentally. 

Contents

1. Features	4
2. Important notes	9
3. A first look at your FR-18 diatonic	11
The sections of your FR-18 diatonic	11
Bellows resistance regulator	11
4. Panel descriptions	12
Treble control panel	12
5. Before you start playing	15
Getting ready to play	15
Connecting the AC adaptor	15
Installing and removing batteries	16
Energy saving function	16
Connecting the FR-18 diatonic to an amplifier, mixer, etc.	17
Attaching the straps	17
Bass strap	18
Securing the adapter and/or MIDI cable	19
Personalizing your FR-18 diatonic	20
Switching the power on and off	21
Turning on the power	21
Turning off the power	21
Using headphones	21
6. Listening to the demo songs	23
7. Using Sets	24
8. Selecting and playing sounds	25
Treble section	25
Selecting sounds for the right hand	25
Selecting the ORCHESTRA/ORGAN mode	26
Transposing the treble section in octave steps	27
Bass and chord section	27
Selecting accordion sounds for the left hand	27
Selecting orchestral sounds for the left hand	28
Orchestral sounds for the bass section and the chord section	29
Switching off sections you don't need (Mute function)	30
Playing drum/percussion sounds	30
Selecting a Drum Set	30
9. Highlighting some practical functions	31
How to balance the various sections	31
Adjusting the chorus and reverb effects	32
Changing the key note of the keyboard	32
Saving the 'Key' setting	32
Changing the configuration of the keyboards (Tablature)	33
Selecting a tablature with its original key	33
Saving your preferred tablature	33
Using the metronome	34
Checking the battery status	34
Musette Detune	34
10. Saving your settings (User Programs)	35
Using User Programs during your performance	35
Saving your current settings	35
Editing a User Program	36

11. Data management via the USB port	37
Saving a User Program Set to a USB memory (optional)	37
Loading User Program Sets from a USB memory (optional)	38
Loading User Set memories from a USB memory	38
Importing Tablature sets	39
Importing optional expansion sounds	39
12. Editing Function settings	41
Selecting the desired function	42
About the indications provided by the treble registers	42
Parameters	43
13. Connecting to MIDI devices	47
Connecting an external MIDI device to the FR-18 diatonic	47
About MIDI channels	47
Communication via the USB MIDI port	48
MIDI parameters	48
14. Miscellaneous	51
Restoring the factory defaults	51
Recovering the factory User Set data	51
Troubleshooting	52
15. Specifications	53
16. Appendix	54
Tablatures (default: key of G unless specified otherwise)	54
Demo Songs	60
Sounds contained in the various Sets	60
Program Change numbers	64
Bank Select and Program Change RX/TX	65
17. Index	69

2. Important notes

In addition to the items listed under "USING THE UNIT SAFELY" on p. 5, please read and observe the following:

Power supply

- Do not connect this unit to same electrical outlet that is being used by an electrical appliance that is controlled by an inverter (such as a refrigerator, washing machine, microwave oven, or air conditioner), or that contains a motor. Depending on the way in which the electrical appliance is used, power supply noise may cause this unit to malfunction or may produce audible noise. If it is not practical to use a separate electrical outlet, connect a power supply noise filter between this unit and the electrical outlet.
- The AC adaptor will begin to generate heat after long hours of consecutive use. This is normal, and is not a cause for concern.
- When installing or replacing batteries, always turn off the power on this unit and disconnect any other devices you may have connected. This way, you can prevent malfunction and/or damage to speakers or other devices.
- Before connecting this unit to other devices, turn off the power to all units. This will help prevent malfunctions and/or damage to speakers or other devices.

Placement

- Using the unit near power amplifiers (or other equipment containing large power transformers) may induce hum. To alleviate the problem, change the orientation of this unit; or move it farther away from the source of interference.
- This device may interfere with radio and television reception. Do not use this device in the vicinity of such receivers.
- Noise may be produced if wireless communications devices, such as cell phones, are operated in the vicinity of this unit. Such noise could occur when receiving or initiating a call, or while conversing. Should you experience such problems, you should relocate such wireless devices so they are at a greater distance from this unit, or switch them off.
- Do not expose the unit to direct sunlight, place it near devices that radiate heat, leave it inside an enclosed vehicle, or otherwise subject it to temperature extremes. Excessive heat can deform or discolor the unit.
- When moved from one location to another where the temperature and/or humidity is very different, water droplets (condensation) may form inside the unit. Damage or malfunction may result if you attempt to use the unit in this condition. Therefore, before using the unit, you must allow it to stand for several hours, until the condensation has completely evaporated.
- Do not allow objects to remain on top of the keyboard. This can be the cause of malfunction, such as keys ceasing to produce sound.
- Depending on the material and temperature of the surface on which you place the unit, its rubber feet may discolor or mar the surface.
You can place a piece of felt or cloth under the rubber feet to prevent this from happening. If you do so, please make sure that the unit will not slip or move accidentally.
- Avoid the use of insecticides, perfumes, alcohol, nail polish, spray cans, etc., near the unit. Swiftly wipe away any liquid that spills on the unit using a dry, soft cloth.

Maintenance

- For everyday cleaning wipe the FR-18 diatonic with a soft, dry cloth or one that has been slightly dampened with water. To remove stubborn dirt, use a mild, non-abrasive detergent. Afterwards, be sure to wipe the instrument thoroughly with a soft, dry cloth.
- Never use benzine, thinner, alcohol or solvents of any kind, to avoid the possibility of discoloration and/or deformation.

Repairs and data

- Please be aware that all data contained in the unit's memory may be lost when the unit is sent for repairs. Important data should always be backed up on a USB memory or written down on paper (when possible). During repairs, due care is taken to avoid the loss of data. However, in certain cases (such as when circuitry related to memory itself is out of order), we regret that it may not be possible to restore the data, and Roland Europe S.p.a. assumes no liability concerning such loss of data.

Precautions for batteries (not supplied)

- The temperature range for use of the batteries depends on the battery type being used. Please see the documentation that came with the batteries.
- Do not use or store batteries at high temperature, such as in strong direct sunlight, in cars during hot weather or directly in front of heaters. This may cause battery fluid leakage, impaired performance and shorten the batteries' service life.
- Do not splash fresh or saltwater on a battery or allow the terminals to become damp. This may cause heat generation and formation of rust on the battery and its terminals.
- Keep the batteries out of reach of babies or small children.
- Do not strike or drop the batteries. Strong impact can cause leakage of battery fluid, heat generation, bursting or fire.
- Never try to connect several batteries in parallel as this may cause leakage of battery fluid, heat generation, bursting or fire.
- Do not alter or remove protective mechanisms or other parts. Never disassemble the batteries.

Additional precautions

- Please be aware that the contents of memory can be irretrievably lost as a result of a malfunction, or the improper operation of the unit. To protect yourself against the risk of losing important data, we recommend that you periodically save a backup copy of important data you have stored in the unit's memory to a USB memory.
- Unfortunately, it may be impossible to restore the contents of data that was stored on a USB memory once it has been lost. Roland Europe S.p.a. assumes no liability concerning such loss of data.
- Use a reasonable amount of care when using the unit's buttons, sliders, or other controls; and when using its jacks and connectors. Rough handling can lead to malfunctions.
- When connecting/disconnecting all cables, grasp the connector itself—never pull on the cable. This way you will avoid causing shorts, or damage to the cable's internal elements.
- To avoid disturbing your neighbors, try to keep the unit's volume at reasonable levels. You may prefer to use headphones, so you do not need to be concerned about those around you (especially when it is late at night).
- When you need to transport the unit, package it in the box (including padding) that it came in, if possible. Otherwise, you will need to use equivalent packaging materials.
- Some connection cables contain resistors. Do not use cables that incorporate resistors for connecting to this unit. The use of such cables can cause the sound level to be extremely low, or impossible to hear. For information on cable specifications, contact the manufacturer of the cable.

Storage devices that can be connected to the FR-18 diatonic's USB port

- The FR-18 diatonic allows you to connect commercially available USB memories. You can purchase such devices at a computer store, a digital camera dealer, etc.
- Use USB memory sold by Roland. We cannot guarantee operation if any other USB memory is used.

Before using external USB memories

- When connecting a USB memory, firmly insert it all the way into the FR-18 diatonic's USB port.
- Do not touch the pins of the FR-18 diatonic's USB port or allow them to become dirty.
- While using an external USB memory, please observe the following points when handling it:
 - To prevent damage from static electrical charges, discharge any static electricity that might be present in your body before handling a USB memory.
 - Do not touch the terminals with your fingers or any metal object.
 - Do not bend or drop a USB memory, or subject it to strong impact.
 - Do not leave a USB memory in direct sunlight or in locations such as a closed-up automobile.
 - Do not allow a USB memory to become wet.
 - Do not disassemble or modify your external USB memory.
- Do not insert anything other than a USB memory (e.g., wire, coins, other types of device) into the USB port. Doing so will damage the FR-18 diatonic's USB port.
- Do not apply excessive force to the connected USB memory or the FR-18 diatonic's USB port.
- Never connect your USB memory to the FR-18 diatonic via a USB hub.
- Never insert or remove a USB memory while this unit's power is on. Doing so may corrupt the unit's data or the data on the USB memory.
- Carefully insert the USB memory all the way in—until it is firmly in place.

Notice

- Roland and V-Accordion are either registered trademarks or trademarks of Roland Corporation in the United States and/or other countries.
- MMP (Moore Microprocessor Portfolio) refers to a patent portfolio concerned with microprocessor architecture, which was developed by Technology Properties Limited (TPL). Roland has licensed this technology from the TPL Group.
- All product names mentioned in this document are trademarks or registered trademarks of their respective owners.

3. A first look at your FR-18 diatonic

Let us first take a look at how the FR-18 diatonic is organized and how it is operated.

The sections of your FR-18 diatonic

Let's briefly look at the various "sections" of your instrument, as that will help you understand how your FR-18 diatonic works.

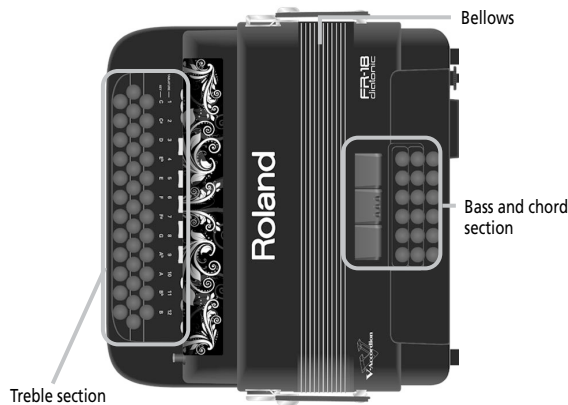

① **Treble section (right-hand manual)**

This section is normally used for playing the melody. It is velocity sensitive.

② **Bass and chord section (left-hand manual)**

This section is normally used to play the accompaniment. The FR-18 diatonic's bass and chord section is velocity sensitive.

③ **Bellows**

The bellows is an extremely important part of any accordion. The movement of the bellows indeed lends expression and dynamics to the sound.

The bellows of the FR-18 diatonic is so accurate and responsive that you have perfect control over your performance.

The bellows' inertia can be set with the resistance regulator and air button.

Bellows resistance regulator

Your FR-18 diatonic is equipped with a bellows resistance regulator and air button that allows you to specify the bellows' inertia (the force needed to push and pull it).

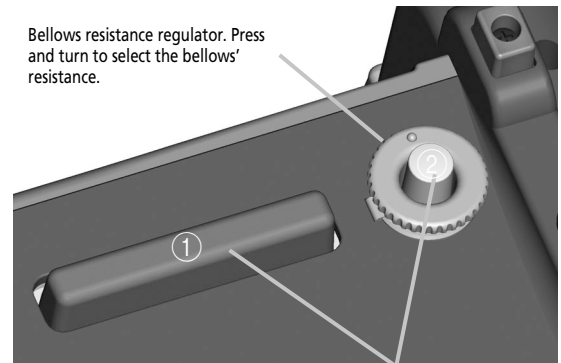

It is located next to one of the bellows clips and mounted onto the air button (which allows you to release remaining air from the bellows without producing sound).

- Press the wheel and rotate it clockwise to select a stronger inertia.
- Press the wheel and rotate it counterclockwise to select a lighter inertia.
- Press either of the two air buttons (1, 2) to purge the remaining air from the bellows and close it without sound.

4. Panel descriptions

Treble control panel

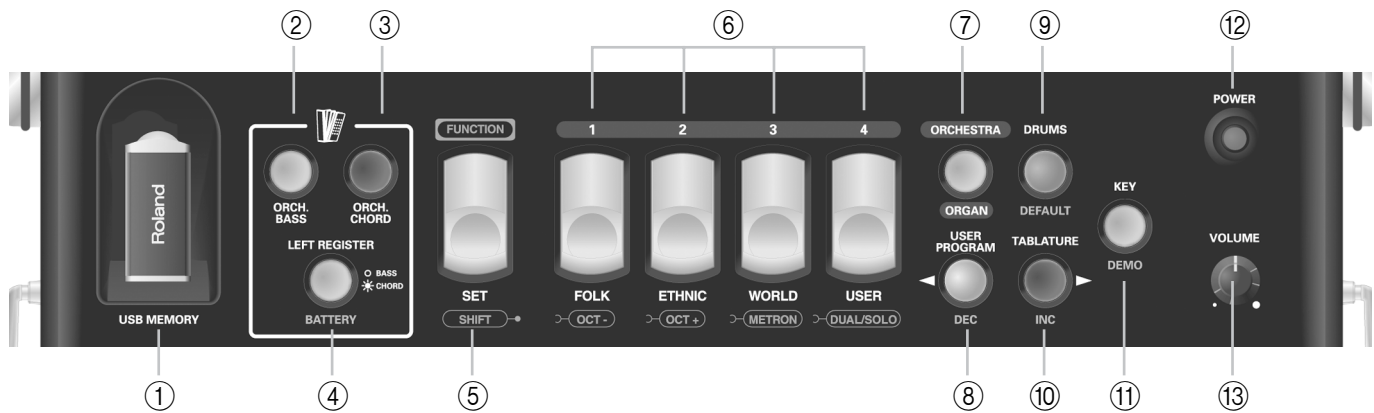

Note: In addition to their main function (top legend), most buttons and registers shown here have a second (sometimes even a third) function (bottom legend), that is usually available in Function mode (see p. 41).

① USB MEMORY port

The USB MEMORY port allows you to connect an optional USB memory to the FR-18 diatonic. It can be used to save and load User Programs, to load User Sets as well as new sounds and new tablatures.

NOTE

Use a USB memory sold by Roland. We cannot guarantee operation if any other USB memory is used.

② ORCH. BASS button

This button allows you to switch orchestral bass mode on/off. When it is on, the bass section plays the selected orchestral sound.

③ ORCH. CHORD button

This button allows you to turn the orchestral chord mode on/off. When it is on, the chord section plays the selected orchestral sound.

④ LEFT REGISTER button

This button is used to assign the three bass registers (the large gray registers) either to the BASS (light off) or to the CHORD (light on) section. See p. 28 for details. It also allows you to check the battery status (page 34).

⑤ FUNCTION/SET register

This register allows you:

- to recall one of the 12 diatonic accordion types (accordion SETs). There are 4 families.
- (FUNCTION mode) to access "hidden" parameter and MIDI functions, such as:
 - editing settings and MIDI parameters
 - changing octaves (page 27)

⑥ Treble registers (1~4)

The Treble section provides 4 switches ("registers") allowing you to select:

- a diatonic accordion type (12 accordion types divided over 4 families – "accordion sets").
- the desired accordion sound of the selected accordion family.

- the desired Orchestral/Organ sound (total 12).
- (FUNCTION mode) the desired preset parameter value, User Program settings.

⑦ ORCHESTRA/ORGAN button

This button allows you to turn the Orchestral/Organ sounds on/off.

⑧ USER PROGRAM/DEC button

This button allows you:

- to turn the User Program On/Off.
- (FUNCTION mode) to decrease parameter values.

⑨ DRUMS/DEFAULT button

This button allows you:

- to switch the Drums function (page 30) on and off.
- (FUNCTION mode) to recall the saved setting for the selected parameter.

⑩ TABLATURE/INC button

This button allows you:

- to select your desired tablature.
- (FUNCTION mode) to increase parameter values.

⑪ KEY/DEMO button

This button allows you:

- to select the Key note in which you want to play your music
- to listen to the FR-18 diatonic's demo songs (press and hold the button).

⑫ POWER button

Press this button to switch FR-18 diatonic on (the button lights) and off (the button goes dark).

NOTE

If you need to turn off the power completely (when using the supplied AC adaptor), first turn off the [POWER] switch, then disconnect the AC adaptor's plug from the wall outlet.

⑬ VOLUME knob

This knob allows you to set the overall volume.

Bass control panel

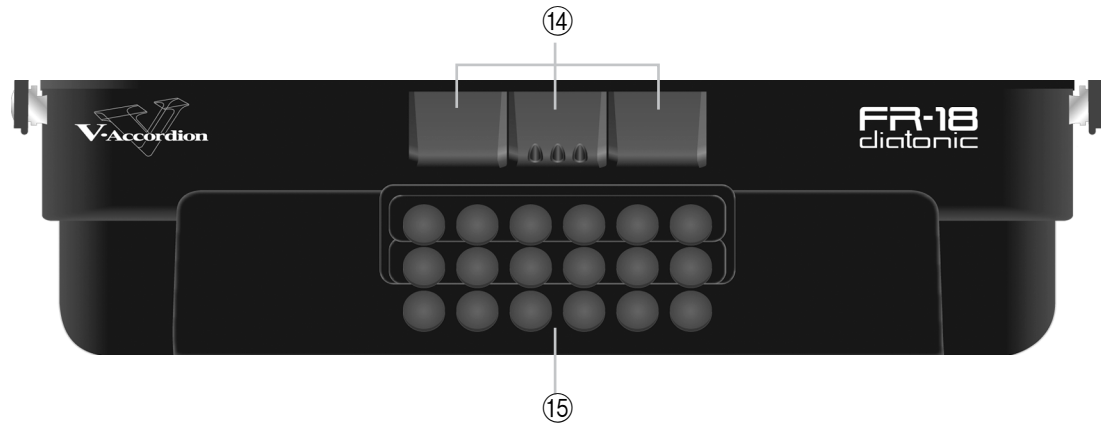

⑭ Bass registers

These switches allow you to select the desired bass and chord sounds. These registers do not illuminate. They include the following types (footages) for accordion sounds:

Bass registers		
Register	Bass	Chord
1	8'	8', 4'
2	16', 8', 4'	8', 4'
3	16', 8'	8', 4'



16'/8'
Full Chord



16'/8'
Chord-3^

The bass registers are also used to select orchestral sounds for the bass or chord section.

⑮ Bass and chord buttons

These 18 button keys are used to play:

- bass notes and chords (like on an acoustic diatonic accordion).
- orchestral bass and orchestral chord sounds;
- drum sounds;.

They are velocity-sensitive.

Battery compartment

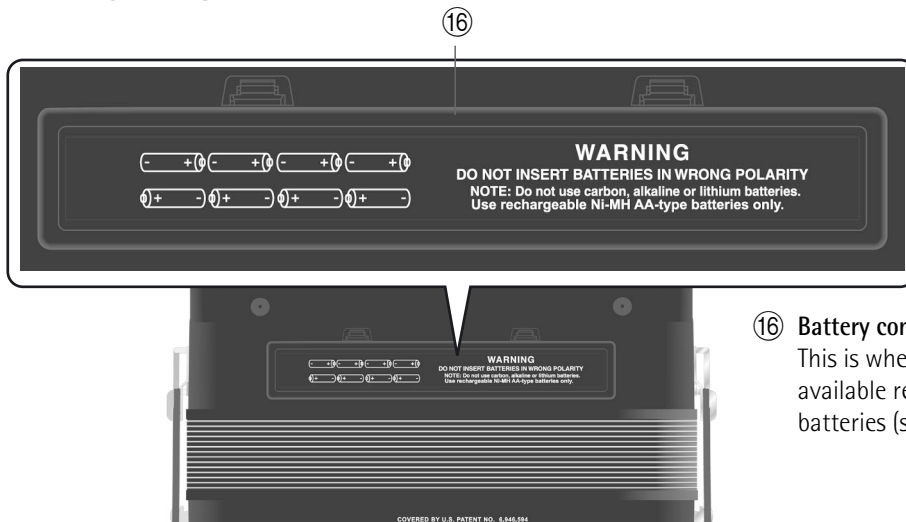

- ①⑥ **Battery compartment**
This is where you install 8 commercially available rechargeable AA-type Ni-MH batteries (see p. 16).

Connection panel

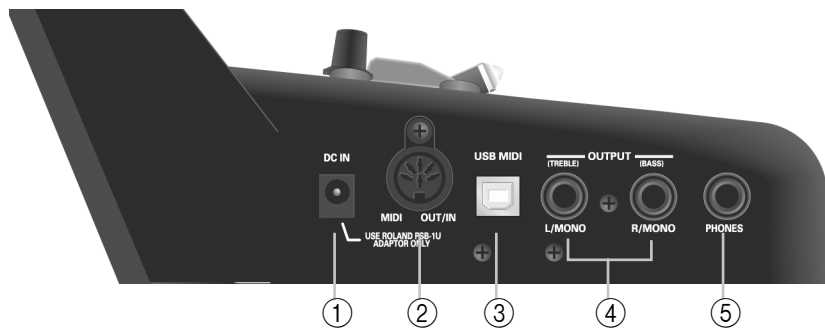

- ① **DC IN socket**
This is where you need to connect the supplied power adapter (PSB-1U). Note that you can also purchase 8 rechargeable AA-type Ni-MH batteries and use the FR-18 diatonic without the adapter.
- ② **MIDI OUT/IN socket**
This socket can be used to connect the FR-18 diatonic to an external MIDI device to receive or transmit MIDI data. When the "MIDI OUT/IN" parameter (see p. 50) is set to "In", the FR-18 diatonic doesn't play: it only receives MIDI messages.
- ③ **USB MIDI port**
This port can be connected to a USB port of your computer (see p. 48). Please use a commercially available USB cable.
- ④ **OUTPUT L/MONO (TREBLE) & R/MONO (BASS) sockets**
These sockets can be connected to an amplifier, a mixing console or a commercially available wireless system. If you use both connectors, the FR-18 diatonic's output is stereo. In that case the signals of the Treble section is transmitted to the L/MONO socket, while the R/MONO socket transmits the bass (and chord) signals. If you only use one audio cable (connected to the "L" or "R" socket), the FR-18 diatonic's output is mono.

- ⑤ **PHONES socket**
This is where you can connect the supplied earphones or optional stereo headphones (Roland RH-series). Doing so does not mute the OUTPUT sockets.

NOTE

When using the supplied earphones, do not set the volume too high (i.e. past "12 o'clock") to avoid distortion.

■ Important handling notes

- After connecting any cable to the FR-18 diatonic, be sure to never place it on the side when not using it.
- Always let FR-18 diatonic stand on its rubber feet (and in the corresponding direction) to avoid damaging the plugs.
- Always handle and move the FR-18 diatonic with care and pay special attention to the cable slack to avoid damaging or bending the cables.
- If you place the FR-18 diatonic on your lap, ensure that the audio and adaptor cables run between your legs (not sideways) to avoid damaging or bending the cables.

5. Before you start playing

Getting ready to play

The FR-18 diatonic is an electronic instrument that requires some form of electrical power. This chapter explains how to power your V-Accordion using the supplied adaptor or 8 commercially available rechargeable batteries (AA type Ni-MH). Consider purchasing such batteries when performing on stage. In addition, since the FR-18 diatonic has no loudspeakers inside, you will learn how to connect it to an external amplification system.

Connecting the AC adaptor

NOTE

To prevent malfunction and/or damage to speakers or other devices, always turn down the volume, and turn off the power on all devices before making any connections.

1. Turn the [VOLUME] knob all the way towards the small dot to minimize the volume.
2. Connect the included power cord to the AC adaptor.

The indicator will light once you plug the AC adaptor into a wall outlet.

Place the AC adaptor so that the side with the indicator (see illustration) faces upwards and the side with textual information faces downwards.

To the FR-18 diatonic's DC IN connector

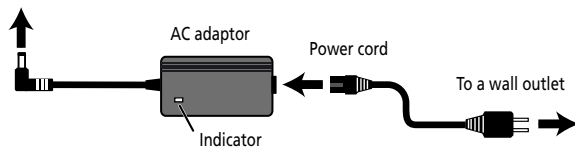

NOTE

Depending on your region, the included power cord may differ from the one shown above.

NOTE

Be sure to use only the AC adaptor supplied with the unit (PSB-1U). Also, make sure the line voltage at the installation matches the input voltage specified on the AC adaptor's body. Other AC adaptors may use a different polarity, or be designed for a different voltage, so their use could result in damage, malfunction, or electric shock.

3. Connect the AC adaptor to the FR-18 diatonic's DC IN jack.

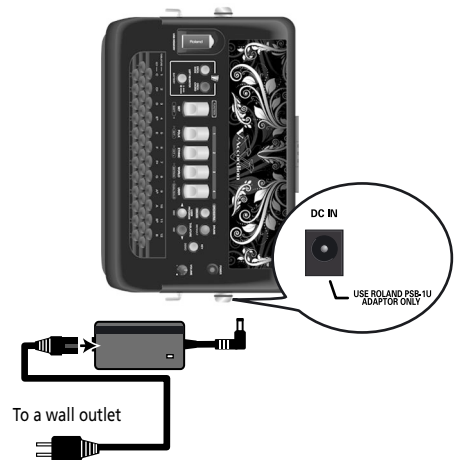

4. Plug the power cord into a power outlet.

Now that the FR-18 diatonic is connected to a wall outlet, you can continue with the section "Switching the power on and off" on p. 21. To use the FR-18 diatonic with batteries, see "Installing and removing batteries" on p. 16.

NOTE

If the FR-18 diatonic is to remain unused for an extended period of time, unplug the adaptor.

NOTE

To prevent the inadvertent disruption of power to your unit (should the plug be pulled out accidentally), and to avoid applying undue stress to the AC adaptor jack, anchor the power cord. "Securing the adapter and/or MIDI cable" on p. 19.

Installing and removing batteries

Your FR-18 diatonic has a compartment into which you can install 8 optional rechargeable AA-type Ni-MH batteries (not supplied). You can therefore play your instrument without connecting the supplied adapter.

1. Switch off the FR-18 diatonic.
2. Remove the cover from the FR-18 diatonic's battery compartment by pressing the two tabs and lifting the cover.

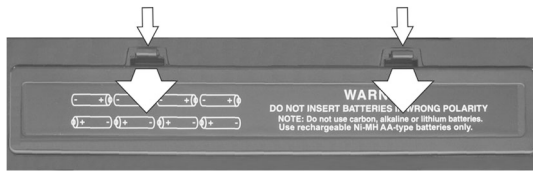

3. Insert 8 rechargeable AA-type batteries into the compartment, taking care to orient them in accordance with the "+" and "-" indications.



4. Close the FR-18 diatonic's battery compartment.

Note about rechargeable batteries

Certain batteries can be recharged several times before they need to be replaced with a new ones. Note that it is normal for the batteries to last increasingly shorter as time goes by. At the end of their life cycle, they may only last one hour, for example. But that is a gradual process.

Battery duration

New or fully charged batteries should last about 5.5 hours (for 2000mAh Ni-MH batteries) during continuous operation.

NOTE

Though it is perfectly possible to use rechargeable batteries, be aware that they cannot be recharged simply by leaving them in the FR-18 diatonic's compartment and connecting the adapter. You will need an external charging unit.

NOTE

We recommend using rechargeable AA-type Ni-MH batteries.

NOTE

When replacing batteries, be sure to insert them correctly (ensure correct polarity).

NOTE

Remove the batteries whenever FR-18 diatonic is to remain unused for an extended period of time.

NOTE

Actual battery life varies according to usage conditions, the quality of the batteries and the number of charging cycles.

Energy saving function

NOTES

This unit has an Auto Power Off function, which automatically switches off the power after a certain amount of time has passed without any buttons being operated.

You can disable the Auto Power Off function. For more about the Auto Power Off function, refer to "Auto Power Off" on p. 46.

Connecting the FR-18 diatonic to an amplifier, mixer, etc.

The FR-18 diatonic needs to be connected to an amplification system. If you are using optional batteries and need to connect the FR-18 diatonic to a PA system or mixer, we recommend using a commercially available wireless system to avoid having to use excessively long signal cables.

You can also use the supplied earphones or a pair of optional headphones (Roland RH-series).

NOTE

To prevent malfunction and/or damage to speakers or other devices, always turn down the volume, and turn off the power on all devices before making any connections.

NOTE

When using the supplied earphones, do not set the volume too high (i.e. past "12 o'clock") to avoid distortion.

1. Turn the [VOLUME] knob all the way towards the small dot to minimize the volume.
2. Switch off all devices.
3. Connect the FR-18 diatonic's OUTPUT jacks to the inputs of your external device.

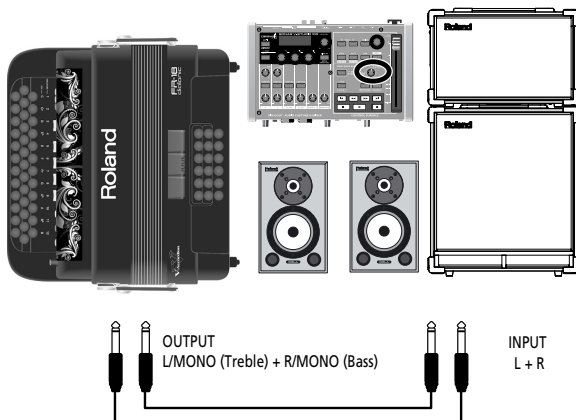

Use either a long signal cable (10m or more) or a commercially available wireless system (recommended).

Please choose unbalanced (mono) cables with 1/4" jacks at one end (for the FR-18 diatonic). The connectors at the other end need to match the input sockets of the device to which you are connecting the FR-18 diatonic.

NOTE

Be sure to read "Important handling notes" on p. 14.

NOTE

If your amplifier is monaural, you only need to connect the L/MONO socket.

NOTE

If you use a commercially available wireless transmitter, the FR-18 diatonic's output signals may distort. In that case, change the FR-18 diatonic's volume setting.

NOTE

You can also use a pair of headphones (Roland RH-series).

Attaching the straps

Proceed as follows to attach the straps to your FR-18 diatonic:

1. Unpack the straps.

The FR-18 diatonic comes with two straps, each with two ends: the upper end is fitted with a velcro strip and the clip, the lower end is not. See the illustration below:



2. Put the FR-18 diatonic on a stable surface as shown in the illustration below.

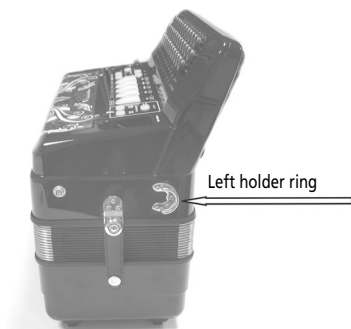

3. Slide the upper end (with the velcro strip) of one strap through the left holder ring (see the illustration).



4. Attach the strap's upper part to the velcro layer below it.

5. Close the security clip to ensure that the strap cannot come loose.



6. Repeat steps (3)~(5) for the other strap.
The upper strap ends should look as follows:



7. Slide the lower end of one strap through the right holder ring as shown.



8. Slide the strap end through the upper eyelet of its plastic buckle (see the illustration).

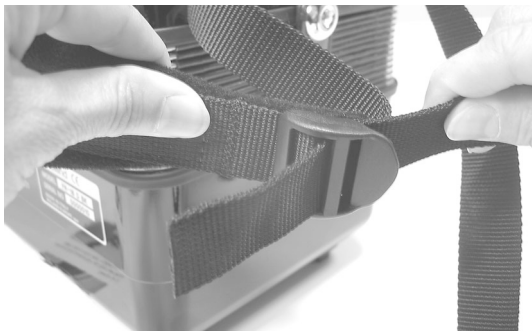

9. Turn the strap end around and insert it into the lower eyelet, then pull it tight.



NOTE

You may want to adjust the length first to suit your preference.

10. Slide the plastic clip over the loose and long lower strap ends to secure the strap.

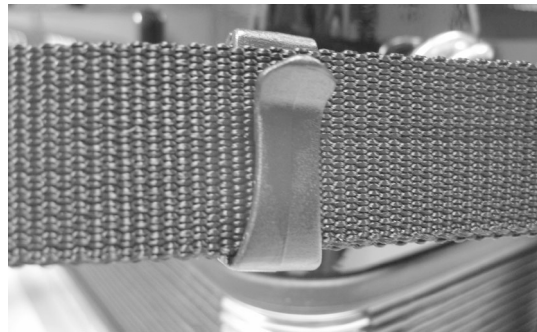

11. Repeat steps (7)~(9) for the other lower strap end.

Bass strap

The FR-18 diatonic's bass strap (used to move the bellows in and out) is made of fabric and fitted with a velcro strip that allows you to adjust its slack.



Securing the adapter and/or MIDI cable

Proceed as follows to ensure that the adapter cable –or a MIDI cable– doesn't come loose while you are playing.

Your FR-18 diatonic comes with an adapter and an attachment strip that allows you to secure the adapter cable and optional MIDI as well as audio cables to the right strap.

1. Prepare the adapter cable and the attachment strip as follows:

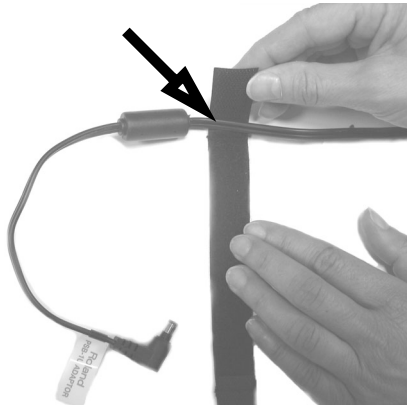

Be sure to attach the strip *before* the ferrite core on the adapter cable. If you like, you can also add the MIDI cable and audio cables to this assembly.

2. Secure the attachment strip as shown in the illustration, making sure that the ferrite core cannot slide out of the loop.

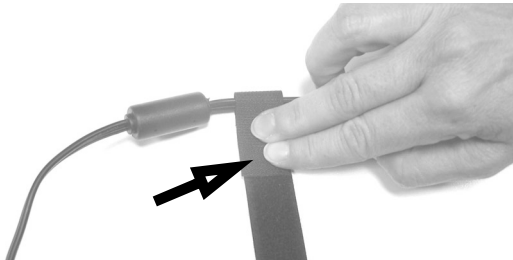

3. Hold the adapter cable close to the right strap and wind the attachment strip around it as shown.



The strip is fitted with a Velcro layer that holds it in place.

4. Keep winding the attachment strip around the strap until your assembly looks as follows:



5. Reverse these steps to remove and disconnect the adapter and/or MIDI and audio cables when you want to stop playing.

Personalizing your FR-18 diatonic

The artwork you see behind the treble registers (above the Roland logo) can be replaced either with one of the sheets supplied with the FR-18 diatonic or with a graphic you create yourself. To do so, proceed as follows:

1. Use the supplied hexagonal wrench to loosen the two screws holding the "traforo" cover:



There is one screw on either side.



Be careful not to turn the screws too far—they should remain in the traforo cover.

2. After loosening both screws, you can open the traforo cover:



NOTE

Be careful not to scratch the housing of your FR-18 diatonic.

3. Remove the sheet from underneath the traforo cover and insert another one.

While creating your own sheet, pay attention to the following:

- You can use your color printer and a graphic program to create your own artwork.
- Be sure to use paper or rather thin media—cardboard is usually too thick.
- For a professional look, be sure to prepare a sheet with the following dimensions: 297mm (L) x 89mm (H).

4. Secure the traforo cover by tightening the two screws using the supplied hexagonal wrench.

Switching the power on and off

Once the connections have been completed (see p. 17), turn on power to your various devices in the order specified. By turning on devices in the wrong order, you risk causing malfunction and/or damage to speakers and other devices.

Turning on the power

1. Turn the [VOLUME] knob all the way towards the small dot to minimize the volume.
2. To switch the FR-18 diatonic on, press its [POWER] button.



The [POWER] button lights.

3. Switch on the external amplifier, mixing console, etc.
4. Turn the [VOLUME] knob clockwise to set the volume to an appropriate level.



5. Adjust the volume of the receiving audio device.

Turning off the power

1. Turn the [VOLUME] knob all the way towards the small dot to minimize the volume.

If you connected the FR-18 diatonic to an amplifier, etc., set its volume to the minimum value as well.

NOTE

This unit is equipped with a protection circuit. A brief interval (a few seconds) after power up is required before the unit will operate normally.

NOTE

This unit has a function that automatically switches off the power after a certain amount of time has passed without any buttons being operated. You can disable this function. See "Auto Power Off" on p. 46.

2. Press the FR-18 diatonic's [POWER] button (its indicator goes dark).



Using headphones

The FR-18 diatonic has a socket for plugging in headphones. This allows you to play without having to worry about bothering others around you, even at night.

1. Plug the headphones into the [PHONES] jack located on the FR-18 diatonic's connection panel.



NOTE

Use stereo headphones. Please use only Roland headphones. Headphones from other manufacturers may be unable to provide sufficient volume.

2. Use the FR-18 diatonic's [VOLUME] knob to adjust the headphone volume.

■ Cautions when using headphones

- To prevent damage to the cord's internal conductors, avoid rough handling. When using headphones, mainly try to handle either the plug or the headset.

- Your headphones may be damaged if the volume of a device is already turned up when you plug them in. Minimize the volume before you plug in the headphones.
- Excessive input will not only damage your hearing, but may also strain the headphones. Please enjoy music at an appropriate volume.

6. Listening to the demo songs

The FR-18 diatonic contains a series of demo songs that illustrate its wide variety of sounds and applications. Here is how to listen to those demo songs and fully appreciate the sounds contained in your diatonic V-Accordion:

1. Switch on the FR-18 diatonic.
See "Switching the power on and off" on p. 21.
2. Press and hold the [KEY/DEMO] button, which will start flashing yellow.



Playback starts automatically with the first demo song. There are 8 demo songs in all. At the end of the first song, the FR-18 diatonic starts playing songs 2, 3 etc.

You can also directly jump to the song you're interested in:

3. Press [DEC]/[INC] to select the demo song you want to listen to.

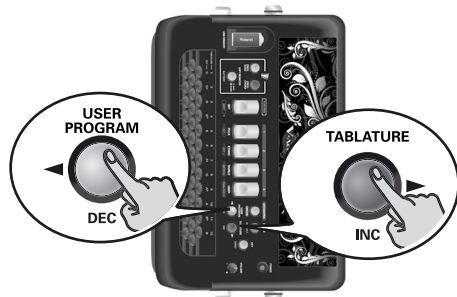

4. Use the [VOLUME] knob to change the volume if it is too loud or too soft.
5. Press [KEY/DEMO] again to leave demo song mode.

NOTE

During demo song playback, the FR-18 diatonic's keyboards cannot be used.

NOTE

All demo songs are copyright by Roland Europe. Public performance or recording of these songs is prohibited.

NOTE

No data for the music that is played will be output from the MIDI OUT/IN socket.

NOTE

You can find the complete list of demo songs in the Appendix on page 60.

7. Using Sets

The FR-18 diatonic is a “virtual” accordion. It recreates the sounds of various accordion instruments and can even generate orchestral sounds (like trumpet, flute, etc.), organ and drum sounds.

Recalling a Set is similar to switching to a different accordion.

The FR-18 diatonic contains 12 Sets divided over 4 families. 3 Set families have been programmed at the factory (“FOLK”, “ETHNIC”, “WORLD”—see the legends below the treble registers) and cannot be changed. One family (“USER”) can be used to load User Sets from an optional USB memory.

Each Set family may comprise several Sets (see below). Recalling a Set immediately changes the settings of the sections presented on p. 25 and configures the treble and bass registers.

Family	Accordion Sets	
1 FOLK	1-1 Folk	(red)
	1-2 Classic	(green)
	1-3 Tradition	(yellow)
2 ETHNIC	2-1 Organetto	(red)
	2-2 Diatonic Folk	(green)
	2-3 SP Folk	(yellow)
3 WORLD	3-1 Alpine	(red)
	3-2 Cajun	(green)
	3-3 Tex Mex	(yellow)
4 USER	4-1 User Set	(red) [Bandoneon]*
	4-2 User Set	(green) [D-Folk]*
	4-3 User Set	(yellow) [Concertina]*

[*] These Sets are supplied from the factory, but they can be replaced by the user.

1. Press the [SET] register. It lights blue.



NOTE

If you do not press a treble register after having pressed [SET] once, Set selection is cancelled after a while.

2. Press one of the treble registers [1]~[4] to select the Set family.



Set selection is handled in the following way:

- If the Set family you select is the same as the one you have been using so far, the FR-18 diatonic selects the next Set within that family.

Example: To go from Set “1-1” to Set “1-3”, you therefore need to press register [1] twice after pressing [SET].

Each Set inside a family (1, 2, 3) has a dedicated color:

1= red, 2= green, 3= yellow

- If you select a different Set family, the FR-18 diatonic switches to the newly selected Set family and recalls the last memory you selected within that family.

NOTE

If you hold down [SET] for more than 2 seconds without pressing another register, the FR-18 diatonic switches to Function mode. In that case, press [SET] again to leave that mode, then repeat step (1).

8. Selecting and playing sounds

Treble section

The Treble section can be played using the 37 treble buttons on the right-hand side.

The sound it produces is determined by the register [1]~[4] you pressed last. This section can be used to play accordion, orchestral and organ sounds.



NOTE

At power-on, the FR-18 diatonic selects the key of G. See "Changing the key note of the keyboard" on p. 32 for how to select a different key.

Selecting sounds for the right hand

This section explains how to select accordion, orchestral and organ sounds for the treble section (right hand). On p. 26, you will learn how to combine accordion notes with an orchestral or organ sound.

■ Accordion sounds

To make your selection:

1. Connect the FR-18 diatonic to an amplifier and switch it on.
See "Switching the power on and off" on p. 21.
2. Press a treble register and start playing on the keyboard.

The following 8 accordion sounds can be assigned to the treble buttons using treble registers [1]~[4]:

Treble Register	Color	Sound*
1 (pressed once)	Green	8', 8'+
1 (pressed again)	Red	16', 8', 8'+
2 (pressed once)	Green	16', 8'
2 (pressed again)	Red	16', 8', 4'
3 (pressed once)	Green	8', 8'+, 8'-
3 (pressed again)	Red	16', 8', 8'+, 8'-, 4'
4 (pressed once)	Green	8', 4'
4 (pressed again)	Red	16', 4'

[*] The accordion sounds that can be selected with the registers depend on the currently selected Set. The sounds shown above refer to Set 1. See page 60 for a list of the sounds available for each Set.

Though the FR-18 diatonic is an electronic musical instrument, it only produces sound when you move the bellows.

3. Play a few notes to audition the sound.

If you wish a different accordion treble sound, press one of the 4 treble registers [1]~[4]. You can choose among eight available sounds, by pressing a treble register either once (green) or twice (red).

NOTE

The FR-18 diatonic has 12 different button layouts. If it seems to sound the wrong notes, see "Changing the configuration of the keyboards (Tablature)" on p. 33 for how to select a different button layout.

■ Orchestral/Organ sounds

Your FR-18 diatonic contains sounds of various musical instruments that are not related to accordion sounds. Those sounds allow you to expand your musical endeavours.

The orchestral sound section available in your FR-18 diatonic comprises 8 sounds.

Every accordion sound set is combined with an orchestral sound set whose 8 sounds are closely related to the musical genre in question.

To select an orchestral sound:

1. Press the [ORCHESTRA/ORGAN] button once.



It lights red to signal that you have entered orchestral sound selection mode.

2. Use treble registers [1]~[4] to select the desired orchestral sound.

You can press each of them either once or twice to choose one of the two **orchestral sounds** available for each register (always starting from the first position).

Treble Register	Color	Sound*
1 (pressed once)	Green	Strings
1 (pressed again)	Red	Ac. Piano
2 (pressed once)	Green	Oboe
2 (pressed again)	Red	Flute1
3 (pressed once)	Green	Ac. Guitar
3 (pressed again)	Red	Brass
4 (pressed once)	Green	Fat Saw Lead

Treble Register	Color	Sound*
4 (pressed again)	Red	Poly Synth

[*] The orchestral sounds that can be selected with the registers depend on the currently selected Set. The sounds shown above refer to Set 1. See page 60 for a list of the sounds available for each Set.

NOTE

This table is only an example of all available orchestral sound sets, as every orchestral sound set is combined with its corresponding accordion set. For the complete list, please see "Sounds contained in the various Sets" on p. 60.

The orchestral sound section of your FR-18 diatonic includes also 4 **organ sounds**, each with a slow/fast rotary effect.

Register	Color	Sound
1 (pressed once)	Green	Blues Slow
1 (pressed again)	Red	Blues Fast
2 (pressed once)	Green	Distortion Slow
2 (pressed again)	Red	Distortion Fast
3 (pressed once)	Green	Full Draw Slow
3 (pressed again)	Red	Full Draw Fast
4 (pressed once)	Green	3rd Percussion Slow
4 (pressed again)	Red	3rd Percussion Fast

To select an organ sound:

1. Press the [ORCHESTRA/ORGAN] button twice.



It **flashes red** to signal that you have entered organ sound selection mode.

NOTE

If you press [ORCHESTRA/ORGAN] button a third time, the treble registers will let you select accordion sounds again.

2. Use treble registers [1]~[4] to select the desired organ sound.

You can press them either once or twice to choose either the Slow or the Fast Rotary effect of the same organ sound.

NOTE

Do not forget to move the bellows in order to hear the notes you are playing.

3. Press the [ORCHESTRA/ORGAN] button again to exit selection mode and go back to the state where the treble accordion section sounds.

Selecting the ORCHESTRA/ORGAN mode

The orchestral or organ sound assigned to the treble section can be played in isolation or together with the treble diatonic sound.

1. Press and hold [SET/SHIFT] while pressing the [4] (DUAL/SOLO) treble register to alternate between DUAL and SOLO modes.

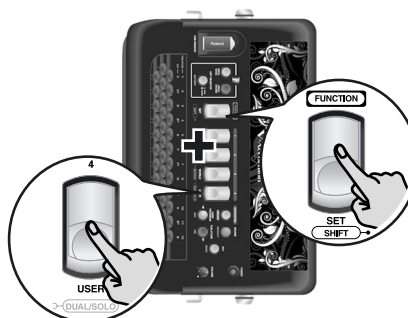

In SOLO mode, the treble keyboard only plays the selected accordion, orchestral or organ sound. DUAL mode means that the orchestral or organ sound is added to the treble accordion sound.

NOTE

If you hold down [SET] for more than 2 seconds without pressing another register, the FR-18 diatonic switches to Function mode. In that case, press [SET] again to leave that mode, then repeat step (1).

NOTE

Each time you switch on your FR-18 diatonic, it selects SOLO mode.

Transposing the treble section in octave steps

The FR-18 diatonic's treble keyboard has a maximum range of 3 octaves. There may be times, however, when you need to play higher or lower notes than its keyboard allows. Unlike an acoustic diatonic accordion, the FR-18 diatonic allows you to transpose the treble keyboard one octave up or down.

1. First specify the section (treble accordion or orchestra/organ) you wish to transpose in octave steps by selecting a sound for it.
2. To transpose one octave down, hold down the [SET/SHIFT] register and press treble register [1] (OCT-).

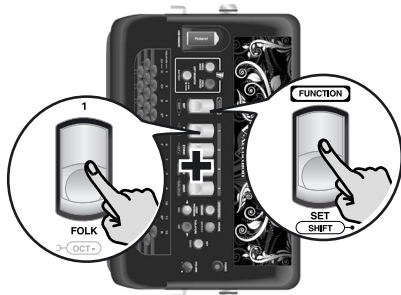

NOTE

If you hold down [SET] for more than 2 seconds without pressing another register, the FR-18 diatonic switches to Function mode. In that case, press [SET] again to leave that mode, then repeat step (2).

3. To transpose one octave up, hold down the [SET/SHIFT] register and press treble register [2] (OCT+).

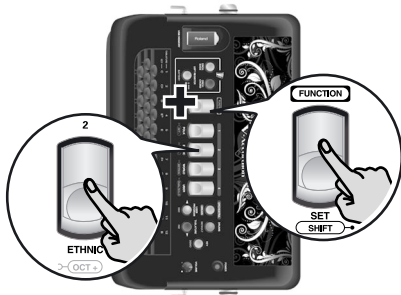

Bass and chord section

The Bass section can be played via buttons for the left hand.

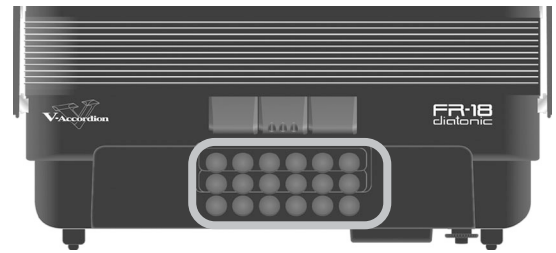

The buttons in this section allow you to play *both* bass notes *and* chords. By default, each of the three rows alternates between a bass note and the related chord. You can, however, change these assignments (tablatures) to better meet your requirements. You can specify for each button whether it should play a bass note, a chord or neither.

The chords use the (sound) register selected for the Bass section—hence the name of this section.

The overall sound the bass and chord section produces is determined by the register you pressed last. The bass and chord buttons can also be used to play accordion or orchestral sounds.

Selecting accordion sounds for the left hand

Here is how to select an accordion sound for the bass and chord section (left hand). Accordion sounds for the left hand can be selected using the 3 registers shown below.



NOTE

The numbers shown in the illustrations above and below do not appear on the registers themselves. They have been added for your reference.

1. Switch on the FR-18 diatonic.

See "Switching the power on and off" on p. 21.

NOTE

After switching on the FR-18 diatonic, the bass registers select accordion sounds.

2. Press one of the 3 bass registers (1~3) to select the desired sound.

These registers do not illuminate.

The following accordion sounds can be selected for the bass and chord buttons:

Bass registers		
Register	Bass	Chord
1	8'	8', 4'
2	16', 8', 4'	8', 4'
3	16', 8'	8', 4'



16'/8'
Full Chord



16'/8'
Chord -3^

3. Choose the desired behavior for the chord buttons:

Press the three bass registers simultaneously to alternate between full chord and "drop third" chords.

The chord buttons can either play full chords or chords where the third (i.e. the constituent note that determines whether a chord is major or minor) has been omitted.

NOTE

The selected chord mode also applies to orchestral chord section.

Selecting orchestral sounds for the left hand

Besides the common accordion bass sounds, the FR-18 diatonic's bass and chord sections allow you to play orchestral sounds. These can be assigned to only the bass buttons, only the chord buttons, or both (in which case you can select different orchestral sounds for the bass and chord buttons). Here is how to select an orchestral sound for the left hand.

■ Selecting an orchestral bass sound

1. **Switch on the FR-18 diatonic.**
See "Switching the power on and off" on p. 21.
2. **Select Set 1.**
See "Using Sets" on p. 24.
3. **Press the [ORCH. BASS] button on the treble control panel to select orchestral bass mode.**

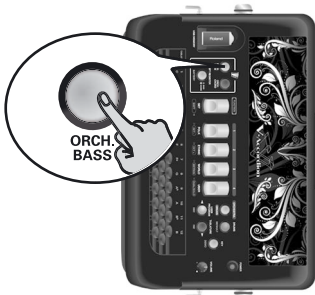

The [ORCH. BASS] button lights red.

4. **Use the 3 bass registers to choose one of the orchestral bass sounds.**



Orchestral bass sounds*	
1	Acoustic Bass
2	Fretless
3	Picked Bass

[*] The orchestral sounds that can be selected with the registers depend on the currently selected Set. See page 60 for a list of the sounds available for each Set.

NOTE

The orchestral sounds that can be selected with the registers depend on the currently selected Set. See page 60 for a list of the sounds available for each Set.

The orchestral bass sound you select replaces the accordion sound played by the bass buttons and has no effect on the chord buttons.

5. **Press the [ORCH. BASS] button again (it goes dark) to exit orchestral bass mode.**

■ Selecting an orchestral chord sound

As stated earlier, the orchestral chord sound can be played with the left-hand buttons defined as chord buttons.

1. **Switch on the FR-18 diatonic.**
See "Switching the power on and off" on p. 21.
2. **Select Set 1.**
See "Using Sets" on p. 24.
3. **Press the [ORCH. CHORD] button on the treble control panel to select orchestral chord mode.**



The [ORCH. CHORD] button lights red.

4. Use the 3 bass registers to choose one of the orchestral chord sounds.



Orchestral chord sounds*	
1	Ac. Piano
2	Str & Choir
3	Super Poly

[*] The orchestral sounds that can be selected with the registers depend on the currently selected Set. See page 60 for a list of the sounds available for each Set.

NOTE

The orchestral sounds that can be selected with the registers depend on the currently selected Set. See p. 60 for a list of the sounds available for each Set.

The orchestral chord sound replaces the accordion sound played by the chord buttons and has no effect on the bass buttons.

5. Press the [ORCH. CHORD] button again to exit ORCH. CHORD mode.

The [ORCH. CHORD] button goes dark.

While orchestral chord mode is active, you can assign a different accordion register to the bass buttons by pressing [LEFT REGISTER] (it must go dark) and the desired Bass register.



Orchestral sounds for the bass section and the chord section

The FR-18 diatonic allows you to swiftly assign one orchestral sound to the bass buttons, and another to the chord buttons.

1. Press the [ORCH BASS] and/or [ORCH CHORD] buttons (they will light).
2. Use the bass registers to select the desired sound.

If [LEFT REGISTER] **lights**, you can select an orchestral sound for the chord buttons (left-hand keyboard). If it is **dark**, you can select an orchestral sound for the bass buttons. Refer to the tables above for the sounds you can select.

NOTE

The [LEFT REGISTER] button has no function when neither the [ORCH BASS] nor the [ORCH CHORD] button lights. Whenever you press [LEFT REGISTER], it changes to lit/dark.

The bass registers affect parts, depending on the status of the [ORCH BASS], [ORCH CHORD] and [LEFT REGISTER] buttons.

ORCH BASS	ORCH CHORD	LEFT REGISTER	Remarks
Dark	Dark	Dark	The bass registers select accordion sounds
Lights	Dark	Dark	The bass registers select orchestral bass sounds
Dark	Lights	Lights	The bass registers select orchestral chord sounds. If you switch off [LEFT REGISTER], you can select accordion sounds for the bass buttons.
Lights	Lights	Lights	The bass registers select orchestral chord sounds. If you switch off [LEFT REGISTER], you can select orchestral sounds for the bass buttons.

Switching off sections you don't need (Mute function)

If, for some reason, you do not want one of the currently active parts to respond to your playing, you can switch it off.

To do it press and hold a single register for a while, as follows:

1. Press and hold a register in the Treble section ([1]~[4]) to mute the treble or Orchestra part.
2. Press and hold a Bass register (1~3) to mute the Bass&Chord, Orchestra Bass, or Orchestra Chord part.
This depends on the part that is currently assigned to the bass registers.
3. A next selection of any register in the Treble or Bass section will switch that part on again.

Playing drum/percussion sounds

Your FR-18 diatonic contains a drum part that can be played in real time in addition to the bass&chord part. There are 4 sets of one or more drum and/or percussion sounds each. Those sounds can be played in real-time using the bass and chord buttons.

1. Press the [DRUMS] button to enter DRUM mode.
The percussion sounds are now added to the bass and chord parts.
2. Press the [DRUMS] button again to exit DRUM mode.

Selecting a Drum Set

Here is how to add drum/percussion sounds to each bass note and chord you play with your left hand.

NOTE

The chosen Drum Set will remain until you change Drum Sets again.

1. Press the [DRUMS] button to enter DRUM mode.
The percussion sounds are now added to the bass and chord parts.
2. Press and hold the [DRUMS] button to enter DRUM Edit mode.



The [DRUMS] button flashes.

The lit treble register shows the currently selected Drum Set.

3. Use treble registers [1]~[4] to select another Drum Set.

Drum Set [1] (Folk)		Drum Set [3] (Tarantel)	
1	Bass Drum + HiHat	1	Tamorra 2
2	Snare + Tambourine	2	Tamorra 1
Drum Set [2] (Jazz)		Drum Set [4] (Latin)	
1	Ride Cymbal	1	Pandeiro 3 + Bass Drum
2	Jazz Snare + Pedal HiHat	2	Pandeiro 5

The bass buttons will play the first sound of the Drum Set, while the buttons used to play chords trigger the second sound of the Drum Set.

4. Press the [DRUMS] button again to leave DRUM Edit mode (the button lights steadily).
5. Press the [DRUMS] button again to leave DRUM mode, when you no longer want to use the drum sounds (the button goes dark).

NOTE

See "Drum Sound Level" on p. 44 for how to set the volume of the drum/percussion sounds.

9. Highlighting some practical functions

This chapter discusses some useful functions, like changing your keyboard layout (tablature), changing your playing tonality, using the metronome, checking the battery status, and so on.

How to balance the various sections

Here is how to change the volume balance between the bass/chord and treble sections.

1. Press and hold the [SET] register (it flashes slowly).

The treble keyboard no longer plays.



2. Press button number 3 of the treble keyboard to select the function that allows you to change the volume balance between bass/chord and treble sections.

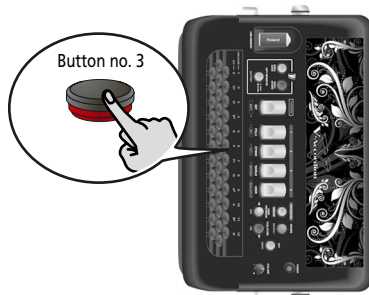

You are now in Function mode—and the Balance parameter is already selected.

The [SET] register flashes rapidly and the treble keyboard can now be used to play notes.

The lit treble register indicates which preset is currently selected.

3. Use registers [1]~[4] to select one of the following settings:

Treble/Bass&Chord balance		
Treble register	Value	On a DJ mixer, this setting would look like this...
1	60 (Bass & Chord)	
2	0 (Equal balance)	
3	30 (Treble)	
4	60 (Treble)	

These are presets prepared at the factory. If the balance sounds right with one of these settings, you are done, otherwise, continue with step (4).

NOTE

When you increase the volume of the Bass&Chord section, the volume of the Treble section is automatically decreased correspondingly and vice versa. See also "Treble/Bass&Chord Balance" on p. 43.

4. (If necessary) Press the [DEC] button to move the balance towards the Bass & Chord section, or the [INC] button to move the balance towards the Treble section.

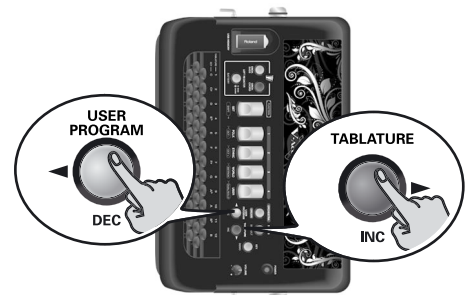

Each time you press the [DEC] button, the volume will fall by 1 unit. If you continue holding the button, the volume will continue falling.

Each time you press the [INC] button, the volume will rise by 1 unit. If you continue holding the button, the volume will continue rising.

5. Press the [DEFAULT] button to return to the last saved value of the currently selected parameter.



6. Press the [SET] register once to return to Function mode (see p. 41), or twice to leave Function mode.

Adjusting the chorus and reverb effects

The FR-18 diatonic contains two digital effects: Chorus and Reverb. The chorus effect gives the impression that several instruments of the same type are playing at the same time (it is similar to detuning several reeds of a register). The reverb effect gives the impression that you are playing in a concert hall, a church or a room. It adds "depth" to the sound.

You can change the type and the level settings of these two effects (see p. 44). Those settings apply to all sections and all Sets.

Changing the key note of the keyboard

The KEY function lets you play the FR-18 diatonic in any key. This is convenient when you are asked to play certain songs in a different key than the one currently assigned to the selected tablature.

The FR-18 diatonic allows you to choose among 12 keys: C, C#, D, Eb, E, F, F#, G, Ab, A, Bb, B

At power-on, the FR-18 diatonic automatically selects the key of G. To change the key, proceed as follows:

1. Press the [KEY] button (it lights).



The first button row of the treble keyboard doesn't play.

2. Press any of the 12 treble buttons in the first row to select the desired key.

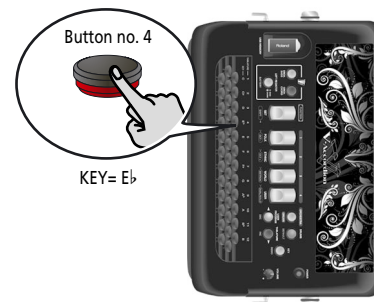

See the key indications above the treble button keyboard. The [KEY] button goes dark.

Saving the 'Key' setting

The FR-18 diatonic allows you to save your preferred key permanently, so that you don't need to select it again each time you switch it on:

1. Press and hold the [SET] register (it flashes).
The Treble keyboard doesn't play.
2. Press the [KEY] button (it lights).
The [SET] register flashes rapidly.
3. Press a treble button in the first row to select your preferred key.
The numbers above the first row of the treble button keyboard will help you choose and save the right key.
4. Press the [SET] register once to exit Function mode.

NOTE

Every time you switch on the FR-18 diatonic, the saved key note will be recalled.

Changing the configuration of the keyboards (Tablature)

A diatonic accordion plays different notes depending on whether the bellows is pushed or pulled. The note mapping in the treble (right hand) and bass (left hand) sections of a diatonic accordion is usually configured by its manufacturer according to a requested keyboard layout commonly referred to as "tablature".

The FR-18 diatonic allows you to change the note configuration of the treble and bass keyboards, because the FR-18 diatonic has no real reeds and no corresponding fixed mechanical parts inside. Consequently you can swiftly set a certain keyboard layout by pressing a couple of buttons and handily change from one tablature to another. (This is impossible on an acoustic diatonic accordion.)

The FR-18 diatonic contains 12 tablatures. See page 54 for details. To recall any of them, either while practising at home or during your performance:

1. Press the [TABLATURE] button (it lights).



2. Press a button in the first row of the treble keyboard (see the silk-screened number above it).

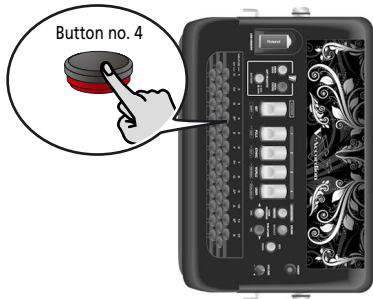

(In this example, we have decided to use tablature number 4.)

You can now change the key of the selected tablature. See "Changing the key note of the keyboard" on p. 32.

Selecting a tablature with its original key

The following procedure allows you to select the tablature's original key.

1. Press the [TABLATURE] button (it lights).
2. Press the [KEY] button (it lights).



The first button row of the treble keyboard doesn't play.

3. Use the first row in the button keyboard to select the new tablature.

See the silk-screened numbers above the first row of the treble button keyboard. The tablature you select will use its factory-set key.

The [TABLATURE] and [KEY] buttons go dark.

Saving your preferred tablature

1. Press and hold the [SET] register (it flashes slowly).

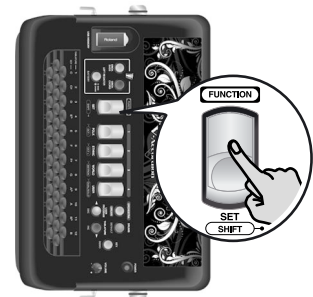

The treble keyboard doesn't play.

2. Press the [TABLATURE] button (it lights).



The [SET] register flashes rapidly.

3. Select the desired tablature by pressing a button in the first row of the treble keyboard.

The numbers above the first row of the treble button keyboard will help you choose and save the right tablature.

4. Press the [SET] register once to exit Function mode.

NOTE

Each time you switch on the FR-18 diatonic, it will load the tablature whose number you saved.

Using the metronome

Your FR-18 diatonic contains a metronome that may come in handy when you are practising new pieces, or during your accordion classes.

1. To start or stop the metronome, press and hold the [SET] register and press register [3] (METRON).



NOTE

See "Metronome Time Signature" on p. 44, "Metronome Tempo" on p. 44 and "Metronome Level" on p. 44 for how to set the metronome's time signature, tempo and level.

NOTE

If you hold down [SET] for more than 2 seconds without pressing another register, the FR-18 diatonic switches to Function mode. In that case, press [SET] again to leave that mode, then repeat step (1).

Checking the battery status

If you are using batteries, to check the current charge status of the batteries:

1. Press and hold the [LEFT REGISTER] button.



Depending on the battery charge status, register [1]~[4] will progressively light for a short while. After ± 2 seconds, the registers return to the following situation.

If all (red and green) registers are lit, the batteries are fully charged. If only the red registers light, the remaining battery life is about 1 hour.

NOTE

To check how your FR-18 diatonic is currently powered, press and hold the [LEFT REGISTER] button:

If the [DRUM] button and the first two registers light during operation, the FR-18 diatonic is powered by the supplied adaptor.

If the [ORCHESTRA] button lights, batteries are used to power the FR-18 diatonic.

NOTE

The battery charge indication is only an approximation.

Musette Detune

An accordion's 8' treble register may consist of 2 or even 3 reeds that are usually tuned apart to provide a richer sound (accordionists call it the "musette effect"). One reed is tuned slightly above, the other slightly below the correct pitch (and the third, if available, is tuned "properly").

The FR-18 diatonic allows you to choose from among 15 different detune settings. These are called "1" (Dry), "2" (Classic), "3" (F-Folk), "4" (American L), "5" (American_H), "6" (North Eur), "7" (German L), "8" (D-Folk L), "9" (Italian L), "10" (German H), "11" (Alpine), "12" (Italian H), "13" (D-Folk H), "14" (French), "15" (Scottish).

See "Musette Detune" on p. 43 for how to select the desired Musette detuning.

NOTE

"Musette Detune" only affects registers that use the 8' reed.

10. Saving your settings (User Programs)

Your FR-18 diatonic contains 4 User Program memories where you can store the settings listed below. Working with those memories has the advantage that you can recall frequently used settings at the press of a button. The User Program settings also include the "address" of the last Set you selected.

The following settings are saved to the User Programs:

Set	Number of the current Set
Treble section	Register
	Octave setting
Orchestra/Organ	Register
	Octave setting
	Level
Bass & Chord section	Register
	On/Off
Orchestral Bass	Register
	Level
	On/Off
Orchestral Chord	Register
	Level
	On/Off
Drum mode	Drum Set number
	Level
	On/Off
Chord Mode	Full Chord, -3°
Key	Selected key
Tablature	Selected tablature number
Orchestra Mode	Dual, Solo

Using User Programs during your performance

1. Press the [USER PROGRAM/DEC] button to enter User Program mode (the button lights).



The treble register corresponding to the last User Program you selected lights.

2. Press the treble register ([1]~[4]) that is assigned to the User Program whose settings you want to use.

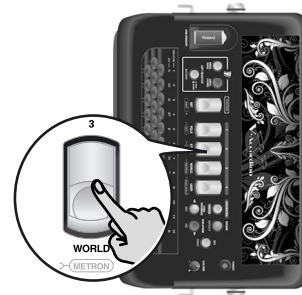

The register you press lights red.

3. Press the [USER PROGRAM/DEC] button again to exit User Program mode. The [USER PROGRAM/DEC] button goes dark. At this point, the FR-18 diatonic returns to the settings you were using before selecting User Program mode.

Saving your current settings

1. Press and hold the [USER PROGRAM/DEC] button (it flashes).



One treble register lights to indicate the User Program that is currently in use.

2. Press the treble register ([1]~[4]) that is assigned to the User Program memory where you want to save your settings. The register you press lights and the [USER PROGRAM/DEC] button lights steadily.

Editing a User Program

You can also change the settings of an existing User Program.

1. Press the [USER PROGRAM/DEC] button to enter User Program mode.
The button lights.
2. Press the treble register ([1]~[4]) that is assigned to the User Program whose settings you want to use.



The register you press lights red.

3. Press and hold the [USER PROGRAM/DEC] button again (it flashes).
4. Change the desired settings (accordion, orchestra registers, etc.).
5. Press the [USER PROGRAM/DEC] button (it flashes rapidly).

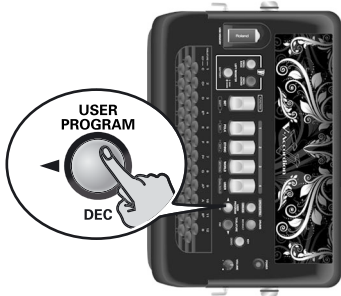

One treble register lights to indicate the User Program that is currently in use.

6. Press the treble register ([1]~[4]) that is assigned to the User Program memory where you want to save your settings.

The register you press lights and the [USER PROGRAM/DEC] button lights steadily.

NOTE

See also "Saving a User Program Set to a USB memory (optional)" on p. 37 and "Saving your current settings" on p. 35.

11. Data management via the USB port

The FR-18 diatonic allows you to save and import User Program settings to/from an optional USB memory connected to its USB port. You can also import Sets, new sounds and new tablatures you copied to your USB memory using your PC. The Sets and sounds are stored internally.

Saving a User Program Set to a USB memory (optional)

Here is how to archive the contents of the FR-18 diatonic's 4 internal User Program memories (file extension ".USD") to an optional USB memory. The FR-18 diatonic can save up to 4 User Program Sets (U01.USD~U04.USD). Each User Program Set contains 4 User Programs.

NOTE

Be sure to connect your USB memory before proceeding.

1. Connect an optional USB memory to the FR-18 diatonic's USB MEMORY port.

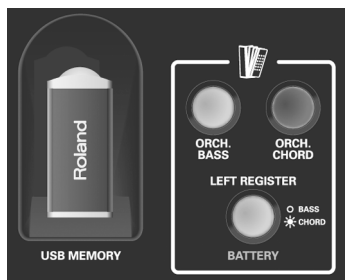

2. Press and hold the [SET] register (it flashes slowly).



The treble keyboard doesn't play.

3. Press button "34" on the treble keyboard to select the "Save User Program" parameter. See page 42 for the location of that button.
4. The [SET] register flashes quickly and registers [1], [2], [3], [4] light green or red: **Green** means that the USB memory contains no settings for the corresponding User Program Set (U01.USD~U04.USD). **Red** means that the USB memory already contains a User Program Set.

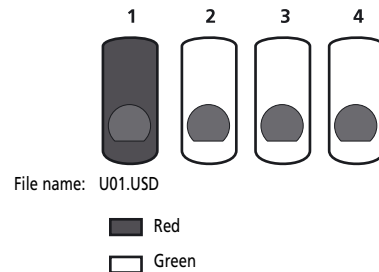

In the example above, the USB memory contains one file (U01.USD).

NOTE

You can overwrite files whose treble register lights red, but in this case you lose the settings of that file.

The "Save User Program" function saves the 4 internal User Programs to a file named "U0\$.USD" on the USB memory (where "\$" is a number from 1 to 4):

Register number	File name
1	"U01.USD"
2	"U02.USD"
3	"U03.USD"
4	"U04.USD"

5. Press treble register [1], [2], [3] or [4] to select the name of the file. See the illustration above for the correspondence of the file names.
6. Press the [SET] register again to exit Function mode.

NOTE

If one of the treble registers flashes red, the FR-18 diatonic has noticed an error:

- Missing USB memory
- Write error
- The USB memory is full

Loading User Program Sets from a USB memory (optional)

The function discussed here allows you to load one of 4 User Program Sets (U01.USD~U04.USD) from a USB memory to the FR-18 diatonic's internal memory.

NOTE

Be sure to connect your USB memory before proceeding.

1. Connect an optional USB memory to the FR-18 diatonic's USB MEMORY port.
2. Press and hold the [SET] register (it flashes slowly).



The treble keyboard doesn't play.

3. Press button "35" on the treble keyboard to select the "Load User Program" parameter. See page 42 for the location of that button.
4. The [SET] register flashes quickly and registers [1], [2], [3], [4] light yellow or red: **Red** means that the USB memory contains no settings for the corresponding User Program Set location.

Yellow means that the USB memory does contain a User Program Set.

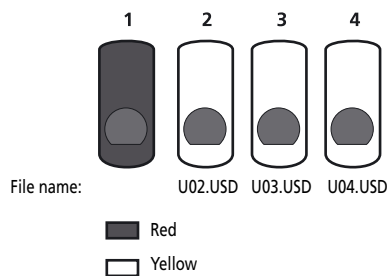

In the example above, the USB memory contains the User Program Set files U02.USD, U03.USD and U04.USD.

The "Load User Program" function loads the User Program Set files depending on the register numbers:

Register number	File name
1	"U01.USD"
2	"U02.USD"
3	"U03.USD"
4	"U04.USD"

5. Press treble register [1], [2], [3] or [4] to load the corresponding User Program Set. You can only select registers that light yellow.
6. Press the [SET] register again to exit Function mode.

NOTE

If one of the treble registers flashes red, the FR-18 diatonic has noticed an error:

- Missing USB memory
- Load error

Loading User Set memories from a USB memory

The FR-18 diatonic allows you to copy individual Sets from a USB memory to the three internal "USER" Set locations. The Set files (with the extension ".STD") must first be copied to a USB memory's root directory before loading them into the FR-18 diatonic's "USER" area.

1. Connect an optional USB memory to the FR-18 diatonic's USB MEMORY port.
2. Press and hold the [SET] register (it flashes slowly).
The treble keyboard doesn't play.
3. Press button "36" on the treble keyboard to select the "User Set" parameter. See page 42 for the location of that button.
4. The [SET] register flashes quickly and registers [1], [2], [3], [4] light yellow or red: **Red** means that the USB memory contains no User Set file (the corresponding treble register does nothing).

Yellow means that the USB memory does contain a User Set file (1, 2, 3 or 4).

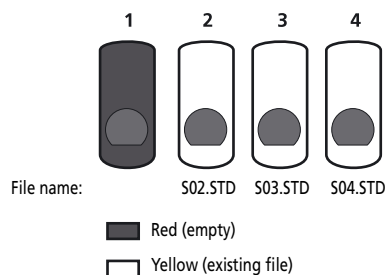

In the example above, the file "S01.STD" doesn't exist on the USB memory.

5. Press treble register [1], [2], [3] or [4] to select the User Set settings you want to load.

Select with register	File name
1	"S01.STD"
2	"S02.STD"
3	"S03.STD"

Select with register	File name
4	"S04.STD"

You can only select registers that light yellow.

- Now select the internal Set memory to which you want to load the selected "User Set" file: press register [1], [2] or [3] that lights yellow.

Register [4] is not available here, because there are only three User Set memories.

All registers go dark to confirm that the selected User Set was imported.

- Press the [SET] register again to exit Function mode.

NOTE

If one of the treble registers flashes red, the FR-18 diatonic has noticed an error:

- Missing USB memory
- Load error

NOTE

See "Recovering the factory User Set data" on p. 51 to load the original factory Sets.

Importing Tablature sets

- Connect an optional USB memory to the FR-18 diatonic's USB MEMORY port.
- Press and hold the [SET] register (it flashes slowly).

The treble keyboard doesn't play.

- Press button "37" on the treble keyboard to select the "Import Tablatures" parameter.

See page 42 for the location of that button.

IMPORTANT REMARK: Each tablature file contains 12 tablature settings. Loading one of them will overwrite the existing tablatures. You cannot select just a single setting from a Tablature Set file.

- The [SET] register flashes quickly and registers [1], [2], [3], [4] light yellow or red:

Red means that the USB memory contains no tablature file (the corresponding treble register does nothing).

Yellow means that the USB memory does contain settings for the corresponding tablature file (1, 2, 3 or 4).

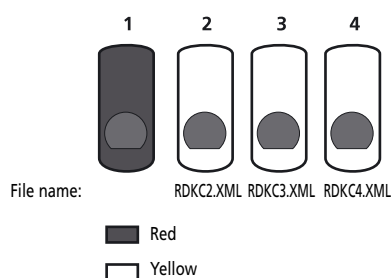

In the example above, the USB memory doesn't contain the "RDCK1.XML" file.

- Press treble register [1], [2], [3] or [4] to select the Tablature Set (12 settings!) you want to load.

Select with register	File name
1	"RDCK1.XML"
2	"RDKC2.XML"
3	"RDKC3.XML"
4	"RDKC4.XML"

- Press the [SET] register again to exit Function mode.

NOTE

If one of the treble registers flashes red, the FR-18 diatonic has noticed an error:

- Missing USB memory
- Load error

Importing optional expansion sounds

The FR-18 diatonic allows you to add new sounds to the internal sounds. The new sounds (files with the ".BID" extension) must be copied to a USB memory, after which you can load them with the FR-18 diatonic.

"Loading" means that they will be copied to a permanent internal memory area. There are two such memory areas ("A" and "B").

- Connect an optional USB memory to the FR-18 diatonic's USB MEMORY port.
- Press and hold the [SET] register (it flashes slowly).

The treble keyboard doesn't play.

- Press button "33" on the treble keyboard to select the "Import expansion sounds" parameter.

See page 42 for the location of that button.

IMPORTANT REMARK: Loading a sound expansion file will overwrite the selected memory bank and replace the sounds that were previously stored there. You cannot select just a single sound from an expansion file.

- The [SET] register flashes quickly and registers [1], [2], [3] and [4] light yellow or red: **Red** means that the USB memory contains no sound expansion file (the corresponding treble register does nothing).

Yellow means that the USB memory does contain a sound expansion file.

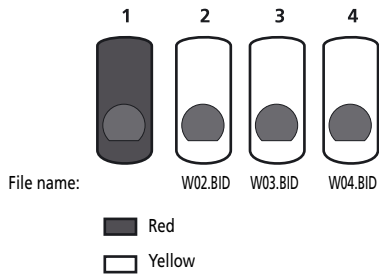

In the example above, the USB memory doesn't contain the file "W01.BID".

5. Press treble register [1]~[4] to select the sound expansion file you want to load.

Select with register	File name
1	"W01.BID"
2	"W02.BID"
3	"W03.BID"
4	"W04.BID"

Treble registers [1]~[4] now light red or green.

NOTE

You can only select registers that light yellow.

6. Now select the internal sound expansion bank to which you want to load the selected expansion file: press register [1] or [2].

Green means that the internal bank in question contains no expansion sounds.

Red means that the bank in question already contains expansion sounds. But you can overwrite them if you like.

During the operation, all treble registers flash green. When they go dark, the selected sound expansion file has been imported.

NOTE

If all four treble registers flash red, the FR-18 diatonic has noticed an error:

- Missing USB memory
- The sound expansion file is already available inside the FR-18 diatonic
- The file is corrupt

NOTE

The load operation may take a few minutes.

NOTE

The FR-18 diatonic does not allow you to load the same sound expansion file for both banks.

7. Press the [SET] register again to exit Function mode.

12. Editing Function settings

The FR-18 diatonic provides a series of specialized parameters that may come in handy when you need to fine-tune the FR-18 diatonic's response to your playing style. Some of these settings can be saved to the FR-18 diatonic's User Programs (see p. 35).

Button	Function	Setting range	Default	See
1	Master Tune	415~440~466Hz	440	p. 43
2	Musette Detune	Dry, Classic, F-Folk, American L, American H, Nord Eur, German L, D-Folk L, Italian L, German H, Alpine, Italian H, D-Folk H, French, Scottish	Depending on the SET you select.	p. 43
3	Treble/Bass&Chord Balance	Bass & Chord 1~63, 0, 1~63 Treble	0	p. 43
4	Orchestra/Organ Level	-40~0~+40	0	p. 43
5	Orchestra Bass Level	-40~0~+40	0	p. 43
6	Orchestra Chord Level	-40~0~+40	0	p. 43
7	Drum Set	Folk, Jazz, Tarantel, Latin	Folk	p. 43
8	Drum Sound Level	Fix Low, Fix Med, Fix High, -40~0~+40	0	p. 44
9	Metronome Time Signature	1/4, 2/4, 3/4, 4/4, 5/4, 6/4, 6/8, 7/8, 9/8	4/4	p. 44
10	Metronome Tempo	20~0~250	120	p. 44
11	Metronome Level	Off, Low, Medium, High	Medium	p. 44
12	Reverb Level	0~127	48	p. 44
13	Reverb Type	Room 1, Room 2, Room 3, Hall 1, Hall 2, Plate, Delay, Panning Dly	Plate	p. 44
14	Chorus Level	0~127	16	p. 44
15	Chorus Type	Chorus 1, Chorus 2, Chorus 3, Chorus 4, FBackChr, Flanger, Short Delay, Short Dly FB	Short Delay	p. 45
16	Bellows Curve	Fixed Low, Fixed Med, Fixed High, X-Light, Light, Standard, Heavy, X-Heavy	Standard	p. 45
17	Bellows Legato	Off, On	On	p. 45
18	Treble Valve Noise	Off, -40~0~+40	0	p. 45
19	Bass Button Noise	Off, -40~0~+40	0	p. 46
20	MIDI TX/RX Channel Treble	1~16, Off	1	p. 48
21	MIDI TX/RX Channel Bass	1~16, Off	2	p. 49
22	MIDI TX/RX Channel Chord	1~16, Off	3	p. 49
23	MIDI TX/RX Channel Orchestra	1~16, Off	4	p. 49
24	MIDI TX/RX Channel Orch. Bass	1~16, Off	5	p. 49
25	MIDI TX/RX Channel Orch. Chord	1~16, Off	6	p. 49
26	Basic MIDI Channel	1~16, Off	13	p. 49
27	Bellows Expression TX	Off, On, Right hand, Left hand	Right hand	p. 49
28	Program Change TX	Off, On	Off	p. 50
29	Auto Power Off	Off, 10, 15, 20 minutes	10 minutes	p. 46
30	MIDI OUT/IN	Out, In	Out*	p. 50

[*] Reset to "Out" when the FR-18 diatonic is switched on.

The "Function" group also contains the following commands that apply to the FR-18 diatonic's memory or a USB memory you may have connected. These are explained on the indicated pages.

Button	Function	See
31	Load factory Set	p. 51
32	USB driver	p. 46
33	Import expansion sounds	p. 39
34	Save User Program	p. 37
35	Load User Programs	p. 38
36	Import User Sets	p. 38
37	Import Tablatures	p. 39

Selecting the desired function

1. Press and hold the [SET] register (it flashes slowly).

The Treble keyboard can now be used to select the desired function. Please refer to the following illustration for the treble buttons you need to press.



2. Press the indicated treble button.
The [SET] register now flashes rapidly, and the Treble keyboard can once again be used to play notes.
3. Use treble registers [1]~[4] to select one of the suggested values. Alternatively, use the [DEC] or [INC] button to select the desired value.
(Sometimes, there are more options than can be selected with the 4 registers.)

You can also press and hold the [DEC]/[INC] buttons to quickly select a significantly higher or lower value. Each time you select a setting that is also assigned to a treble register, the register in question lights. While changing the setting with the [DEC]/[INC] buttons, use the treble registers as a guide. You will notice that one of the registers lights for each setting that can also be selected by pressing a register.

NOTE

Press the [DRUMS/DEFAULT] to return to the last setting you saved for the currently selected parameter.

4. Press the [SET] register twice to leave the FR-18 diatonic's Function mode.

About the indications provided by the treble registers

While the FR-18 diatonic's four treble registers are used to select some of the available "Function" settings, each parameter usually provides more settings than there are treble registers. Settings not directly available need to be selected using the [DEC]/[INC] buttons.

That is why the FR-18 diatonic uses the following system to provide at least a clue of the value you selected:

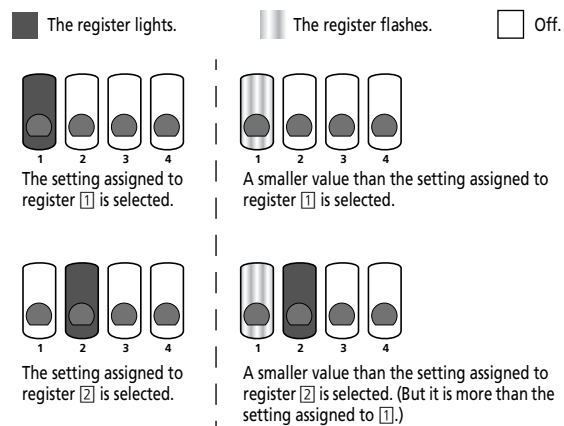

Parameters

All parameters except "MIDI OUT/IN" can be saved in the Global area (common to all Sets).

NOTE

The small dot "•" means "factory setting".

Master Tune 1

415~440~466 (Hz) Default setting: 440

This parameter allows you to change the FR-18 diatonic's overall tuning. The factory default, "440", represents the reference pitch used by all electronic musical instruments. The settings you can select with the registers are:

Register	Value	Register	Value
1	415	3	448
2•	440	4	466

Musette Detune 2

Dry, Classic, F-Folk, American L, American H, Nord Eur, German L, D-Folk L, Italian L, German H, Alpine, Italian H, D-Folk H, French, Scottish Default setting: Depends on the selected Set

This parameter allows you to choose the system used for detuning the 8' reeds of the selected register. The settings you can select with the registers are:

Register	Value	Register	Value
1	Classic	3	Italian L
2	Nord Eur	4	French

Treble/Bass&Chord Balance 3

Bass & chord 1~63,0, 1~63 Treble Default setting: 0

This parameter is used to set the balance between the Treble and Bass sections. When you press register [1], the treble section is inaudible, while pressing register [4] means that the bass and chord section is no longer audible. The settings you can select with the registers are:

Register	Value	Register	Value
1	Bass & Chord (60)	3	Treble 30
2•	Equal balance (0)	4	Treble 60

NOTE

See also "How to balance the various sections" on p. 31.

Orchestra/Organ Level 4

-40~0~+40 Default setting: 0

This parameter allows you to set the level of the orchestral sounds. It can be useful to create the desired "mix" (volume balance) with the treble accordion sounds.

Register	Value	Register	Value
1	-40	3	+20
2•	0	4	+40

Orchestra Bass Level 5

-40~0~+40 Default setting: 0

This parameter allows you to set the level of the orchestral bass section. It can be useful to create the desired "mix" (volume balance) with the sound assigned to the chord section (page 29).

Register	Value	Register	Value
1	-40	3	+20
2•	0	4	+40

Orchestra Chord Level 6

-40~0~+40 Default setting: 0

This parameter allows you to set the level of the orchestral chord section. It can be useful to create the desired "mix" (volume balance) with the sound assigned to the bass section (page 29).

Register	Value	Register	Value
1	-40	3	+20
2•	0	4	+40

Drum Set 7

Folk, Jazz, Tarantel, Latin Default setting: Folk

This parameter allows you to select the type of drum/percussion instruments you wish to play simultaneously with the bass and chord section. See also "Playing drum/percussion sounds" on p. 30.

Register	Setting	Register	Setting
1•	Folk	3	Tarantel
2	Jazz	4	Latin

Drum Sound Level

8

Fix Low, Fix Med, Fix High, Default setting: 0
-40~0~+40

This parameter allows you to set the audio level of the drum sounds. Select "Fix Low" (low), "Fix Med" (medium) or "Fix High" (high) to use a preset level value. If you select a value, it is added to, or subtracted from, the standard value ("0").

Register	Value	Register	Value
1	Fix Med	3•	0
2	-40	4	+40

Metronome Time Signature

9

1/4, 2/4, 3/4, 4/4, 5/4, 6/4, 6/8, 7/8, Default setting: 4/4
9/8

This parameter allows you to set the metronome's time signature. See page 34 for how to activate the metronome.

Register	Value	Register	Value
1	1/4	3•	4/4
2	3/4	4	5/4

Metronome Tempo

10

20~250 Default setting: 120

This parameter allows you to set the metronome tempo. See page 34 for how to activate the metronome.

Register	Setting	Register	Setting
1	Adagio (72 BPM)	3	Allegro (144 BPM)
2•	Moderato (120 BPM)	4	Presto (192 BPM)

Metronome Level

11

Off, Low, Medium, High Default setting: Medium

This parameter allows you to change the metronome's level when it is too loud or too soft. See page 34 for how to activate the metronome.

Register	Value	Register	Value
1	Off	3•	Medium
2	Low	4	High

Reverb Level

12

0~127 Default setting: 48

This parameter allows you to set the volume of the reverb effect with respect to the accordion and/or orchestral sounds. It applies to all sections that are currently switched on. The settings you can select with the registers are:

Register	Value	Register	Value
1	0 (no reverb)	3	96
2•	48	4	127

Reverb Type

13

Room 1~3, Hall 1~2, Plate, Delay, Default setting: Plate
Panning Dly

This parameter allows you to specify what kind of effect the Reverb processor should generate. The available options are:

Type	Explanation
Room1 Room2 Room3	These effects simulate the reverberation of a room. They provide a well-defined spacious reverberation.
Hall1 Hall2	These types simulate the reverberation of a concert hall with a deeper reverberation than the Room reverbs.
Plate	This effect type simulates a plate reverb (a studio device using a metal plate to simulate natural Reverb).
Delay	This is a conventional delay that produces echo effects.
PanningDly	This is a special delay in which the delayed sounds move left and right. It is effective when you are listening in stereo.

Register	Value	Register	Value
1	Room1	3•	Plate
2	Hall 1	4	Panning Dly

Chorus Level

14

0~127 Default setting: 16

This parameter allows you to set the volume of the chorus effect. It applies to all sections that are currently switched on. The settings you can select with the registers are:

Register	Value	Register	Value
1	0 (no chorus)	3	64
2•	16	4	127

Chorus Type 15

Chorus 1~4, FBack Chr, Flanger, Short Delay, Short Dly FB Default setting: Short Delay

Chorus broadens the spatial image of the sound, adding richness. You can choose from 8 types of chorus. The available options are:

Type	Explanation
Chorus 1 Chorus 2 Chorus 3 Chorus 4	These are conventional chorus effects that add spaciousness and depth to the sound.
FBack Chr	This is a chorus with a flanger-like effect and a soft sound.
Flanger	This is an effect that sounds somewhat like a jet airplane taking off or landing.
Short Delay	This is a delay with a short delay time.
ShortDly FB	This is a short delay with many repeats.

Register	Value	Register	Value
1	Chorus 1	3•	Short Delay
2	Flanger	4	ShortDly FB

Bellows Curve 16

Fixed Low, Fixed Med, Fixed High, X-Light, Light, Standard, Heavy, X-Heavy Default setting: Standard

This parameter allows you to adapt the FR-18 diatonic's expressive potential to your playing style. If you think the sounds don't respond the way you would like them to, try another curve that better "translates" your movements.

There are three "**Fixed**" curves that always use the same value, no matter how hard or lightly you push/pull the bellows (no dynamic control). "Low" means that a low value is used, "Med" represents a medium value and "High" a high value.

The remaining settings do depend on the strength with which you push/pull the bellows, but in different ways: "**Light**" means that you do not need to push/pull hard to achieve a meaningful effect. "**X-Light**" requires even less strength (the "X" stands for "extra"). "**Standard**" refers to a normal response. "**Heavy**" provides a greater variety of nuances and "**X-Heavy**" is even more detailed. It would be a good idea to select each curve without the "Fixed" addition, play a few notes, select the next curve, etc. until you find the response that feels just right.

Register	Value	Register	Value
1	Fixed High	3•	Standard
2	Light	4	Heavy

Bellows Legato 17

Off, On Default setting: On

This parameter only applies to percussive orchestral sounds, like piano, guitar, xylophone, etc. It lets you choose what kind of behavior is most suited to the music you wish to play when you press and hold a button while opening and closing the bellows.

Register	Setting	Meaning
1	Off	Percussive orchestral sounds are controlled by the bellows. When you change the direction of the bellows, the new note will restart from the beginning and sound percussive.
2•	On	Percussive orchestral sounds, like piano, vibe, guitar, and so on, are played in a "legato" fashion: when you change the direction of the bellows while holding a treble button, the new note will be the continuation of the note you started with the opposite bellows direction. In most cases, this means that the new note will not sound very percussive (no noticeable attack).

Treble Valve Noise 18

Off, -40~0~+40 Default setting: 0

You will probably agree that electronic sounds must not only reproduce the basic timbre of an existing signal, but also the original instrument's behavior and typical "noises" in order to be perceived as authentic. In the case of a guitar that would be the sliding noise of the fingers. An accordion, on the other hand, produces mechanical valve noises that cannot be suppressed on an acoustic instrument.

Use this parameter to specify how prominent the noise produced by the simulated Treble valves should be. The settings you can select with the registers are:

Register	Value	Register	Value
1	Off	3•	0
2	-20	4	+20

Bass Button Noise

19

Off, -40~0~+40

Default setting: 0

The bass section of almost all accordion instruments can be played via buttons. Such buttons produce a typical noise when pressed. Use this parameter to specify how prominent that button noise should be. The settings you can select with the registers are:

Register	Value	Register	Value
1	Off	3•	0
2	-20	4	+20

- Switch off the FR-18 diatonic (see p. 21), wait a few seconds, then switch it back on again.

NOTE

See also "Communication via the USB MIDI port" on p. 48.

Auto Power Off

29

Off, 10, 15, 20 minutes

Default setting:
10 minutes

This parameter allows you to specify how long the FR-18 diatonic should wait before switching itself off while you are not using it.

Register	Value	Register	Value
1	Off	2	15 minutes
2•	10 minutes	3	20 minutes

WARNING: Be aware that any unsaved changes are lost when the FR-18 diatonic is switched off by this function. Be sure to save all important settings as soon as you can (page 35).

USB Driver

32

Generic, Vendor

Default setting: Generic

Normally, you don't need to install a driver in order to connect the FR-18 diatonic to your computer via the USB connector.

However, if some problem occurs, or if the performance is poor, using the original Roland driver may solve the problem. If you do so, make the following setting to specify the USB driver you intend to use before you install the driver on your computer.

The procedure is as follows:

- Press and hold the [SET] register until its blue indicator starts flashing.
- Press treble button 32.
- Press register [1] or [2]:

Register	Value	Meaning
1•	Generic	Choose this if you want to use the standard USB driver that was included with your computer. Normally, you should use this mode.
2	Original	Choose this if you want to use a USB driver downloaded from the Roland website (www.roland.com).

13. Connecting to MIDI devices

Your FR-18 diatonic can also transmit or receive MIDI data, thus providing an even greater versatility. In this section, we'll look at what MIDI is and does and which MIDI functions are available on the FR-18 diatonic.

■ What's MIDI?

MIDI, short for "Musical Instrument Digital Interface", was developed as a universal standard for exchange of performance data with external devices. By connecting the FR-18 diatonic to an external MIDI device and exchanging performance data, you can control one device from another. For instance, you can output sound from other instruments, switch sounds or receive MIDI data from an external sequencer that cause your FR-18 diatonic to play.

Connecting an external MIDI device to the FR-18 diatonic

The FR-18 diatonic has one MIDI socket that can be used to either transmit (OUT) or receive (IN) MIDI data.

1. Turn the volume all the way down on the FR-18 diatonic and the MIDI device you are about to connect.



2. Use a MIDI cable (sold separately) to connect the MIDI sockets to each other.

Connection to transmit MIDI data to an external device:

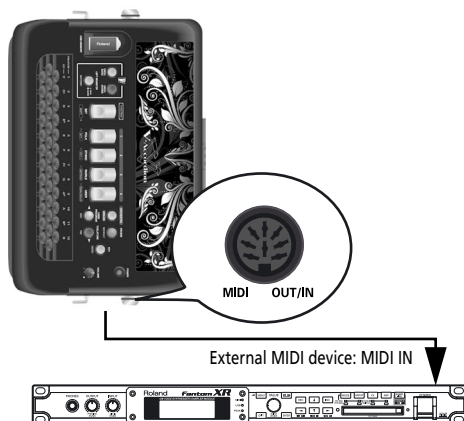

Connection to receive MIDI data from an external device:

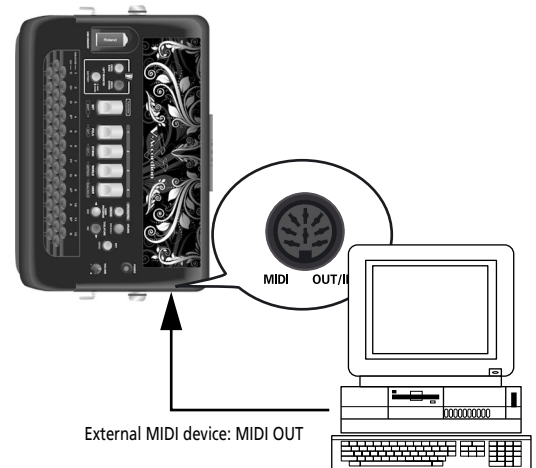

3. Adjust the volume level on the FR-18 diatonic and the connected device.
4. Set the "MIDI OUT/IN" parameter.
See "MIDI OUT/IN" on p. 50. Select "OUT" to transmit MIDI data to an external device. (This is the default setting.)
Set it to "IN" to receive MIDI data from an external device.

About MIDI channels

MIDI can simultaneously transmit and receive messages on 16 channels, so that up to 16 instruments (or parts of a module or synthesizer) can be controlled. Nowadays, most instruments –like your FR-18 diatonic– are multitimbral, which means that they can play several musical parts with different sounds. This requires the use of several MIDI channels. The FR-18 diatonic, for instance, has several accordion and orchestral sections that can be played simultaneously. They can transmit and receive on different channels.

The FR-18 diatonic's sections use the following MIDI channels:

Part	Channel
Treble	1
Bass	2
Chords	3
Orchestra (Treble) or Organ	4
Orchestra Bass	5
Orchestra Chord	6
DRUMS sounds (see p. 30)	10
Basic channel (for selecting Sets)	13

However, if you wish or need to, you can assign the sections of your FR-18 diatonic different channels than those assigned at the factory.

Communication via the USB MIDI port

If you use a USB cable (commercially available) to connect the FR-18 diatonic's USB MIDI port to a USB port of your computer, you'll be able to do the following.

By transferring MIDI data between the FR-18 diatonic and your sequencer software, you'll be able to enjoy a wide range of possibilities for music production and editing.

1. Use a standard USB cable (A→B-type connectors, commercially available) to connect the FR-18 diatonic to your computer as shown below.

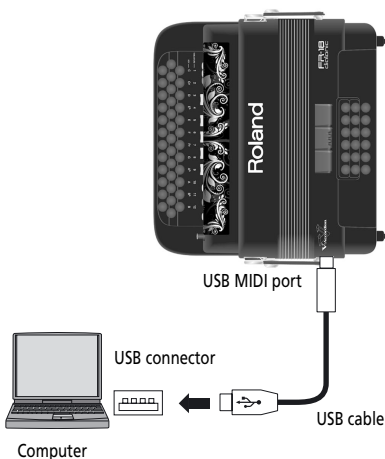

2. Select the USB driver you want to use (see p. 46).
3. Refer to the Roland website for system requirements.
Roland website: <http://www.roland.com/>

If the computer doesn't "see" the FR-18 diatonic

Normally, you don't need to install a driver in order to connect the FR-18 diatonic to your computer. However, if some problem occurs, or if the performance is poor, using the Roland original driver may solve the problem.

For details on downloading and installing the Roland original driver, refer to the Roland website: <http://www.roland.com/>

Specify the USB driver you want to use, and then install the driver. For details, refer to page 46.

■ Caution

- To avoid the risk of malfunction and/or damage to external speakers, always turn the volume all the way down and switch off the power on all devices before you make any connections.

- Only MIDI data can be transmitted and received via USB. Audio data cannot be transmitted or received.
- Switch on the power to the FR-18 diatonic before you start up the MIDI application on your computer. Never turn the FR-18 diatonic's power on/off while your MIDI application is running.

MIDI parameters

The MIDI parameters belong to the "Function" environment. The setting procedure is therefore the same. See p. 42 for details.

General remark: MIDI data are only transmitted when "MIDI OUT/IN" (see p. 50) is set to "Out". The "RX" part mentioned below is only used when "MIDI OUT/IN" is set to "In".

MIDI TX/RX Channel Treble

20

1~16, Off

Default setting: 1

This parameter allows you to set the MIDI channel for the treble (accordion) section. This assignment applies both to the transmission ("TX") and reception ("RX") of MIDI data. Select "Off" if the treble section should neither receive nor transmit MIDI data.

The procedure for setting (and checking) the MIDI channel using the registers is slightly different from the usual procedure, because it also involves using the [ORCHESTRA/ORGAN] button.

Press [ORCHESTRA/ORGAN] once (it lights):

Register	Status	MIDI channel
1	lights	1
	flashes	2
	dark	Off
2	lights	3
	flashes	4
	dark	Off
3	lights	5
	flashes	6
	dark	Off
4	lights	7
	flashes	8
	dark	Off

Press [ORCHESTRA/ORGAN] twice (it flashes):

Register	Status	MIDI channel
1	lights	9
	flashes	10
	dark	Off

Register	Status	MIDI channel
2	lights	11
	flashes	12
	dark	Off
3	lights	13
	flashes	14
	dark	Off
4	lights	15
	flashes	16
	dark	Off

You could press [ORCHESTRA/ORGAN] a third time (it goes dark) to quickly select "Off" (no MIDI channel).

MIDI TX/RX Channel Bass

21

1~16, Off

Default setting: 2

This parameter allows you to set the MIDI channel for the bass buttons (i.e. all left-hand buttons that do not play chords). Select "Off" if the bass section should neither receive nor transmit MIDI data.

NOTE

See "MIDI TX/RX Channel Treble" for the setting procedure using the treble registers and the [ORCHESTRA/ORGAN] button.

MIDI TX/RX Channel Chord

22

1~16, Off

Default setting: 3

This parameter allows you to set the MIDI channel for the chord buttons when they are used to play the selected accordion register. Select "Off" if the chord section should neither receive nor transmit MIDI data.

NOTE

See "MIDI TX/RX Channel Treble" for the setting procedure using the treble registers and the [ORCHESTRA/ORGAN] button.

MIDI TX/RX Channel Orchestra

23

1~16, Off

Default setting: 4

This parameter allows you to set the MIDI channel for the Treble section's orchestral/organ part. Select "Off" if the Orchestra/Organ section should neither receive nor transmit MIDI data.

NOTE

See "MIDI TX/RX Channel Treble" for the setting procedure using the treble registers and the [ORCHESTRA/ORGAN] button.

MIDI TX/RX Channel Orch. Bass

24

1~16, Off

Default setting: 5

This parameter allows you to define the MIDI channel for the ORCH BASS part.

NOTE

See "MIDI TX/RX Channel Treble" on p. 48 for the setting procedure using the treble registers and the [ORCHESTRA/ORGAN] button.

MIDI TX/RX Channel Orch. Chord

25

1~16, Off

Default setting: 6

This parameter allows you to define the MIDI channel for the ORCH CHORD part.

NOTE

See "MIDI TX/RX Channel Treble" for the setting procedure using the treble registers and the [ORCHESTRA/ORGAN] button.

Basic MIDI Channel

26

1~16, Off

Default setting: 13

This parameter allows you to set the basic MIDI channel. The "Basic Channel" can be used for selecting Sets from an external MIDI device (using program change numbers). Please see "Program Change numbers" on p. 64 for the program change numbers of the Sets.

NOTE

See "MIDI TX/RX Channel Treble" on p. 48 for the setting procedure using the treble registers and the [ORCHESTRA/ORGAN] button.

Bellows Expression TX

27

Off, On, Right hand, Left hand

Default setting:
Right hand

The strength/speed with which the bellows is pressed or pulled influences the sound – which corresponds to an acoustic accordion's response. This effect can be translated into a MIDI message most external instruments understand.

The MIDI standard provides a message ("control change") for remotely controlling the volume of an external instrument: CC11. It is chiefly used for expression purposes (similar to the way in which a guitarist or organ player uses a volume pedal).

The FR-18 diatonic can manage expression messages in the following ways:

- **Off**
No expression messages are sent via MIDI.
- **On**
Expression messages are sent via MIDI.
- **Right hand**
Only the "right-hand" MIDI channels transmit expression messages.

■ **Left hand**

Only the "left-hand" MIDI channels transmit expression messages.

Register	Setting	Register	Setting
1	Off	3•	Right hand
2	On	4	Left hand

NOTE

"MIDI OUT/IN" is reset to "Out" when you switch off the FR-18 diatonic.

Program Change TX

28

Off, On

Default setting: Off

This is a MIDI filter, i.e. a parameter that allows you to specify whether or not the given MIDI data type should be transmitted. "TX" is short for "transmission". This means two things: (1) the filter only applies to program changes *sent* by the FR-18 diatonic, and (2) it is only meaningful when the "MIDI OUT/IN" parameter is set to "Out".

Program change messages are used to select sounds or memories on the receiving instrument simply by recalling another sound (or memory) on the transmitting instrument. The FR-18 diatonic transmits program changes when you select Sets (on the Basic Channel) and registers (on the MIDI channel assigned to the section for which you are selecting a different register). Select "Off" if you don't need that.

Register	Value	Register	Value
1•	Off	2	On

NOTE

All of the FR-18 diatonic's registers transmit program change/bank select clusters when pressed. And when you set the "MIDI OUT/IN" parameter to "In", the FR-18 diatonic also receives those messages.

MIDI OUT/IN

30

Out, In

Default setting: Out

This parameter allows you to set the function of the FR-18 diatonic's MIDI OUT/IN socket.

Register	Value	Register	Value
1•	Out	2	In

■ **Out**

Select this setting if you want to play on the FR-18 diatonic's keyboards and transmit the MIDI data generated by your playing to an external device.

■ **In**

Select this setting if you want to receive MIDI data generated by an external device. In this case, the FR-18 diatonic can only be played from an external MIDI device.

NOTE

See p. 47 for the MIDI channels the FR-18 diatonic's parts use.

14. Miscellaneous

Restoring the factory defaults

You can reset the FR-18 diatonic to its factory settings, which means that your own settings (including the User Programs) are replaced by the settings the FR-18 diatonic contained when you first got it. Consider archiving your settings on a USB memory before loading the factory defaults.

1. Switch off the FR-18 diatonic (see p. 21).
2. Hold down treble registers [1] and [4] while switching the FR-18 diatonic back on.

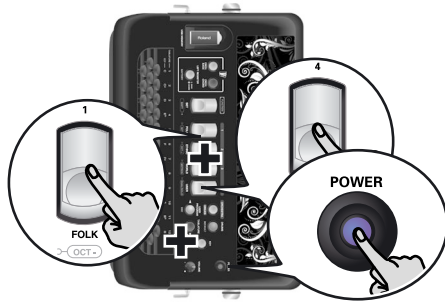

3. Wait until treble registers [1]~[4] start flashing, then release them.
The FR-18 diatonic starts the initialization process. While the initialization is in progress, the [ORCH. BASS], [ORCH. CHORD] and [LEFT REGISTER] buttons as well as the four treble registers flash. When it is complete, the four treble registers stop flashing.

NOTE

This operation does not erase the expansion sounds.

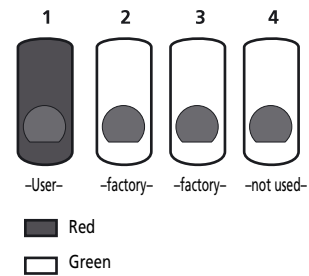

4. Press treble register [1], [2] or [3] to select the Set memory you want to initialize.
The FR-18 diatonic loads the factory data for the selected Set memory.
5. Press the [SET] register twice to exit Function mode.

Recovering the factory User Set data

There may be times when you no longer need your User Set settings and prefer to use the Set data the FR-18 diatonic contained when you first bought it. To do so, proceed as follows:

1. Press and hold the [SET] register (it flashes slowly).
The treble keyboard doesn't play.
2. Press button "31" on the treble keyboard to select the "Load factory Set" parameter.
See page 42 for the location of that button.
3. The [SET] register flashes quickly and registers [1], [2], [3] light red or green:
Green means that the corresponding Set memory contains no User Set data and therefore doesn't need to be initialized.
Red means that Set memory in question contains User Set data and can be initialized if you like.

Troubleshooting

This section provides an overview of points to check and actions to take when the FR-18 diatonic does not function as you expect. Feel free to contact your Roland dealer if your issue remains unsolved after reading through this section.

No sound

■ **Did you turn the [VOLUME] knob all the way to the small dot?**

Set it to a higher value.

■ **Did you set the balance all the way to one section?**

Change this setting and try again. See "How to balance the various sections" on p. 31 and "Treble/Bass&Chord Balance" on p. 43.

■ **Are you moving the bellows while triggering accordion sounds?**

The Treble and Bass & Chord sections only produce sound if you move the bellows while playing notes (like on an acoustic diatonic accordion).

No sound is heard when an external amplifier is connected

■ **Did you switch on the connected amplifier?**

Please check this.

■ **Did you connect the audio cables to the correct sockets?**

If so, check the cables for possible damage.

The bellows exhibits an erratic behavior

If the bellows doesn't work as expected, causing notes to sound even while it is not moved, its sensors may need resetting.

To do so, switch off the FR-18 diatonic, then press and hold the [ORCH.BASS] and [TABLATURE/INC] buttons while switching the FR-18 diatonic back on. If this operation doesn't solve the problem, contact your Roland dealer.

The button keyboards play the wrong notes

You may have selected the wrong tablature setting or the wrong key. See "Selecting a tablature with its original key" on p. 33.

Alternatively, you may have loaded different tablature settings and are now using one of those (see p. 39). Please check the file in question on your computer.

No sound when you play on a button keyboard

You may have muted the section in question. See "Switching off sections you don't need (Mute function)" on p. 30 for how to activate it again.

No power

■ **Did you disconnect the adapter?**

Connect the supplied adapter, or install commercially available batteries.

■ **Did the FR-18 diatonic go off after several seconds?**

The "Auto Power Off" function may be active. Set it to "Off" (page 46).

The FR-18 diatonic does not respond to your playing

■ **Did you set the "MIDI OUT/IN" parameter to "In"?**

In that case, the FR-18 diatonic only responds to MIDI messages. Set the parameter to "Out" (page 50).

■ **Are you moving the bellows while triggering accordion sounds?**

The Treble and Bass sections only produce sound if you move the bellows while playing notes (like on an acoustic diatonic accordion).

Issues related to the bass buttons

■ **Why do some bass buttons trigger chords?**

Because you changed the assignments by selecting a different tablature (see p. 33).

■ **Why are the chords played with the chord buttons incomplete?**

Because you selected the behavior where the third is omitted. Select full chord mode (see p. 28).

MIDI-related issues

■ **What MIDI channels does the FR-18 diatonic use by default?**

See the table on page 47.

■ **The FR-18 diatonic does not change sounds when my sequencer transmits program change numbers.**

The program change number probably lies outside the range of the FR-18 diatonic's registers (see "Program Change numbers" on p. 64). Such "excess" program numbers are ignored by the FR-18 diatonic.

■ **The FR-18 diatonic does not receive the MIDI messages I recorded for it.**

That's because the "MIDI OUT/IN" parameter is currently set to "Out". Set it to "In" (page 50).

■ **The external sequencer keeps displaying a "MIDI Buffer Overflow" message**

The bellows sends too many data at once (its data are transmitted on five channels simultaneously). You may be able to solve the problem by setting the "Bellows Expression TX" parameter (see p. 49) to "Right hand" or "Left hand", depending on which section needs to transmit expression messages for the bellows.

Other issues

■ **Can't read the/write to USB memory**

Are you using a USB memory made by another manufacturer than Roland?

15. Specifications

■ Keyboards

Right hand: 37 buttons, velocity sensitive, selectable tablature and key.

Left hand: 18 bass buttons, velocity sensitive, selectable tablature and key (same as for right hand), selectable chord button behavior (full chord or omitted third)

■ Bellows

Real pneumatic detection of the bellows pressure (high-resolution pressure sensor), high-resolution bellows resistance regulator

■ Sound source

Max polyphony: 128 voices

Wave ROM: 64MB of waveforms (8+8MB expansion sounds)

Tones: 12 accordion Sets, each including:

8 treble registers, 8 orchestral sounds, 4 organ sounds (slow/fast Rotary settings for each)

3 bass & chord registers, 3 Orchestra Bass registers, 3 Orchestra Chord registers

Treble reed footages: 5

Bass reed footages: 3

Chord reed footages: 2

■ PBM (Physical Behavior Modeling)

Noises: stopping-reed growl, closing valve noise, left button noise

Individual reed simulation: hysteresis threshold, expression curve, pressure-variant filter, pressure-variant pitch deviation

Reed sound wave switching: by bellows acceleration, by note repetition speed

■ Musette tuning

Micro tuning presets: 15 (Dry, Classic, F-Folk, American L/H, North Europe, German L/H, D-Folk L/H, Alpine, Italian L/H, French, Scottish)

■ Effects

Reverb: 8 types, Chorus: 8 types

Rotary (Slow/Fast) for organ sounds

■ Panel controls

Knobs: VOLUME

Panel switches: 4 Treble registers + ORCHESTRA/ORGAN button, SET/FUNCTION register, 3 bass registers, ORCH. BASS button, ORCH. CHORD button, LEFT REGISTER button, KEY/DEMO button, USER PROGRAM button, DRUMS button, TABLATURE button, POWER button

■ Operation modes

ORCHESTRA/ORGAN modes: Solo, Dual

Key: 12 possible keys (C, C#, D, Eb, E, F, F#, G, Ab, A, Bb, B)

Tablatures: 12 types

Bass & Chord with drum/percussion sounds: On/off

Octave: Down, 0, Up (for Treble and Orchestra/Organ)

4 User Program memories

■ Power supply

AC adaptor (PSB-1U)

Batteries (AA-type rechargeable Ni-MH x 8)

■ Current draw

500mA

■ Expected battery life under continuous use (using Ni-MH 2000mAh batteries):

±5.5 hours

Actual battery life varies according to usage conditions, the quality of the batteries and the number of charging cycles. *Be sure to use only rechargeable Ni-MH batteries.*

■ Connectors

OUTPUT sockets (L/Mono, R/Mono), PHONES socket

USB MIDI port (computer connection)

USB MEMORY port (storage devices)

MIDI OUT/IN socket (function adjustable via parameter)

DC IN socket: for supplied Roland PSB-1U AC adaptor

■ Dimensions

375 (H) x 365 (W) x 195 (D) mm

14-13/16 (H) x 14-3/8 (W) x 7-11/16 (D) inches

■ Weight

5.3kg/11 lbs 11 oz (without straps or optional batteries)

■ Supplied accessories

PSB-1U AC adaptor

Owner's Manual

Straps

1/4"→1/4" phone (guitar) cable

Earphones (with 1/8"→1/4" adaptor plug)

Strip for securing the adapter, MIDI and/or audio cables

Hexagonal wrench

Replaceable "traforo" inlay sheets

■ Options

Accordion soft bag

NOTE

In the interest of product improvement, the specifications and/or appearance of this unit are subject to change without prior notice.

16. Appendix

Tablatures (default: key of G unless specified otherwise)

Tablature 1

TABLATURE	1	2	3	4	5	6	7	8	9	10	11	12	
KEY	C	C#	D	E ^b	E	F	F#	G	A ^b	A	B ^b	B	
	—	A ^b 3 B ^b 3	A3 C#4	E ^b 4 G4	A ^b 4 A ^b 4	A4 B ^b 4	E ^b 5 C#5	A ^b 5 G5	A5 A ^b 5	E ^b 6 B ^b 5	A ^b 5 C#6	—	
	—	E3 G3	G3 B3	C4 D4	E4 F4	G4 A4	C5 B4	E5 D5	G5 F5	C6 A5	E6 B5	G6 D6	—
	B2 E3	D3 F#3	G3 A3	B3 C4	D4 E4	G4 F#4	B4 A4	D5 C5	G5 E5	B5 F#5	D6 A5	G6 C6	

A ^b +	A ^b	G+	G	C+	C
B-	B	D+	D	G+	G
E ^b +	E ^b	E+	E	F+	F
B ^b +	B ^b	A-	A	F+	F
—	—	—	—	—	—
—	—	—	—	—	—

Tablature 2

TABLATURE	1	2	3	4	5	6	7	8	9	10	11	12	
KEY	C	C#	D	E ^b	E	F	F#	G	A ^b	A	B ^b	B	
	—	A ^b 3 B ^b 3	B ^b 3 C#4	E ^b 4 G4	A ^b 4 A ^b 4	B ^b 4 B ^b 4	E ^b 5 C#5	A ^b 5 G5	B ^b 5 A ^b 5	E ^b 6 B ^b 5	A ^b 6 C#6	—	
	—	E3 G3	G3 B3	C4 D4	E4 F4	G4 A4	C5 B4	E5 D5	G5 F5	C6 A5	E6 B5	G6 D6	—
	B2 E3	D3 F#3	G3 A3	B3 C4	D4 E4	G4 F#4	B4 A4	D5 C5	G5 E5	B5 F#5	D6 A5	G6 C6	

A ^b +	A ^b	G+	G	C+	C
B-	B	D+	D	G+	G
E ^b +	E ^b	E+	E	F+	F
B ^b +	B ^b	A-	A	F+	F
—	—	—	—	—	—
—	—	—	—	—	—

□ Closing the bellows
■ Opening the bellows

Tablature 3

TABLATURE	1	2	3	4	5	6	7	8	9	10	11	12	
KEY	C	C#	D	E ^b	E	F	F#	G	A ^b	A	B ^b	B	
	—	A ^b 3 G3	A3 B ^b 3	E ^b 4 C#4	A ^b 4 G4	A4 B ^b 4	E ^b 5 C#5	A ^b 5 G5	A5 B ^b 5	E ^b 6 C6	A6 E6	—	
	—	E3 F3	G3 B3	C4 D4	E4 F4	G4 A4	C5 B4	E5 D5	G5 F5	C6 A5	E6 B5	A ^b 6 E ^b 6	
		B2 D3	D3 F#3	G3 A3	B3 C4	D4 E4	G4 F#4	B4 A4	D5 C5	G5 E5	B5 F#5	D6 A5	G6 D6

B-	B	C+	D	G+	G
A ^b +	A ^b	G+	G	C+	C
B ^b +	B ^b	A-	A	F+	F
E ^b +	E ^b	E+	E	F+	F
G-	G	D-	D	F#-	F#
E-	E	A-	A	C#+	C#

Tablature 4

TABLATURE	1	2	3	4	5	6	7	8	9	10	11	12	
KEY	C	C#	D	E ^b	E	F	F#	G	A ^b	A	B ^b	B	
	—	A3 C4	C#4 E ^b 4	F4 G4	A4 B ^b 4	C#5 D5	F5 E ^b 5	A5 G5	C#6 B ^b 5	F6 D6	A6 E ^b 6	—	
	—	E3 G3	A ^b 3 B3	C4 D4	E4 F4	A ^b 4 A4	C5 B4	E5 D5	A ^b 5 F5	C6 A5	E6 B5	A ^b 6 C#6	
		B2 D3	D3 F#3	G3 A3	B3 C4	D4 E4	G4 F#4	B4 A4	D5 C5	G5 E5	B5 F#5	D6 A5	G6 C6

D+	D	G+	G	C+	C
G+	G	C+	C	F+	F
A-	A	D-	D	B ^b +	B ^b
E+	E	A+	A	B ^b +	B ^b
B-	B	F#+	F#	E ^b +	E ^b
A ^b +	A ^b	C#+	C#	A ^b +	A ^b

- Closing the bellows
- Opening the bellows

Tablature 5

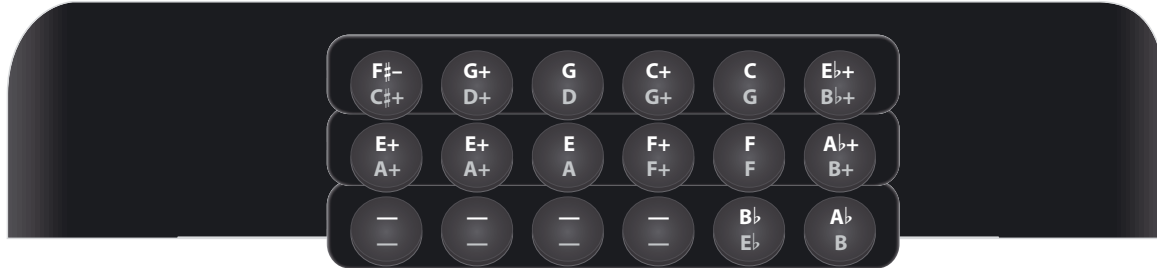
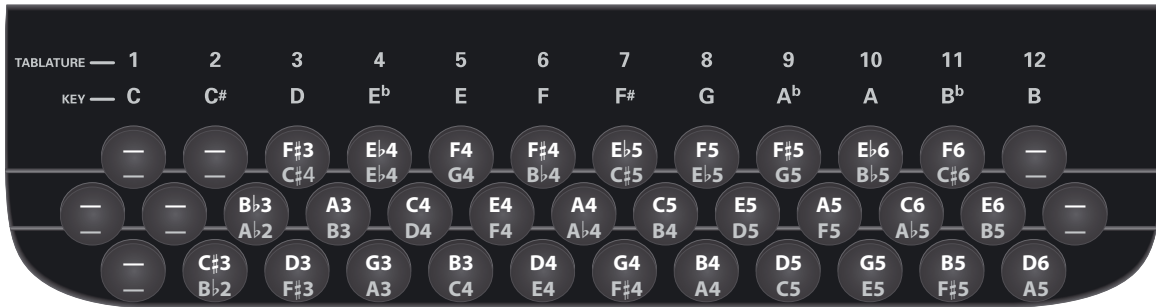

Tablature 6 (key of B)

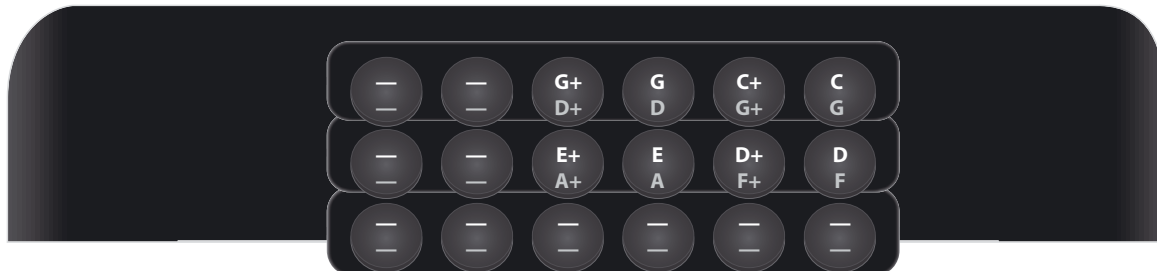
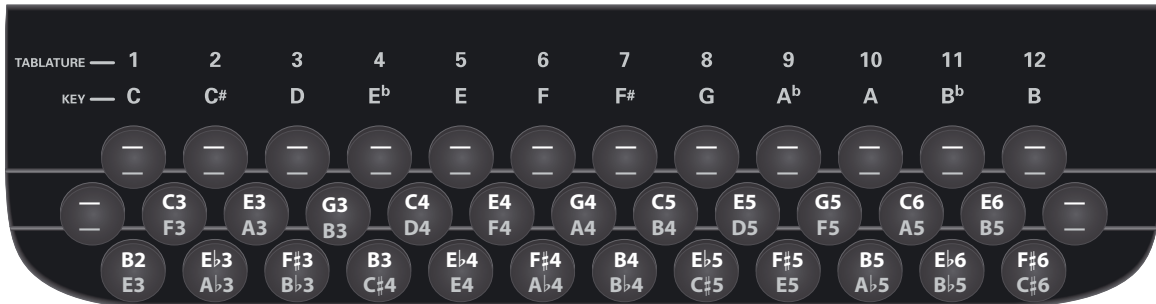

□ Closing the bellows
■ Opening the bellows

Tablature 7

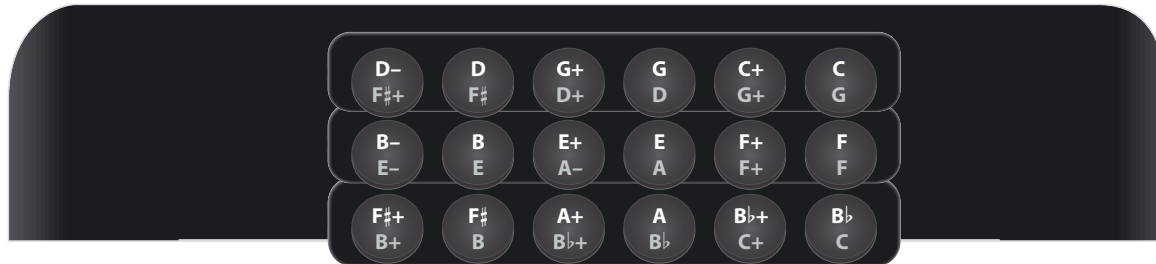
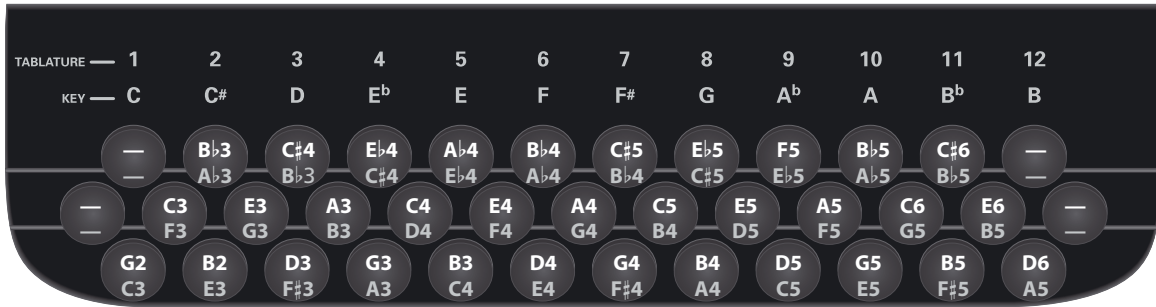

Tablature 8

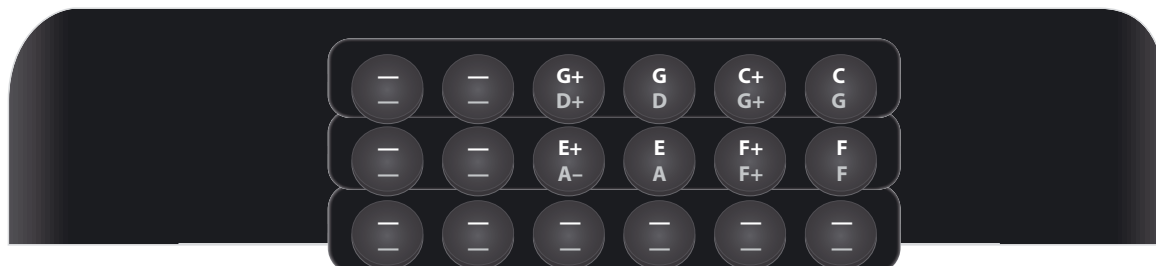
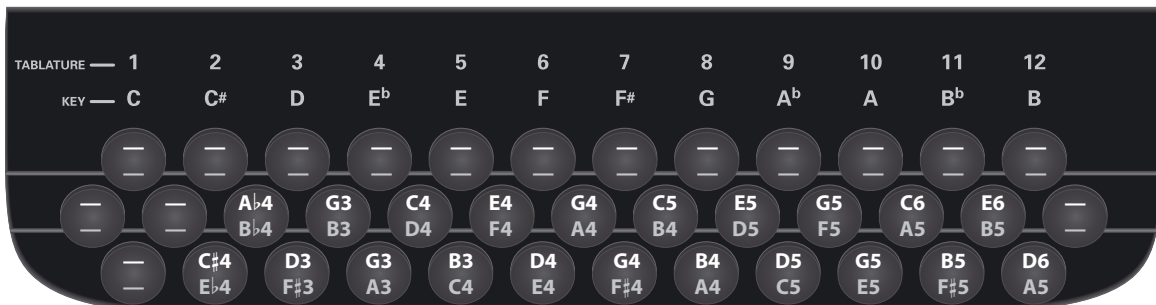

□ Closing the bellows
 ■ Opening the bellows

Tablature 9

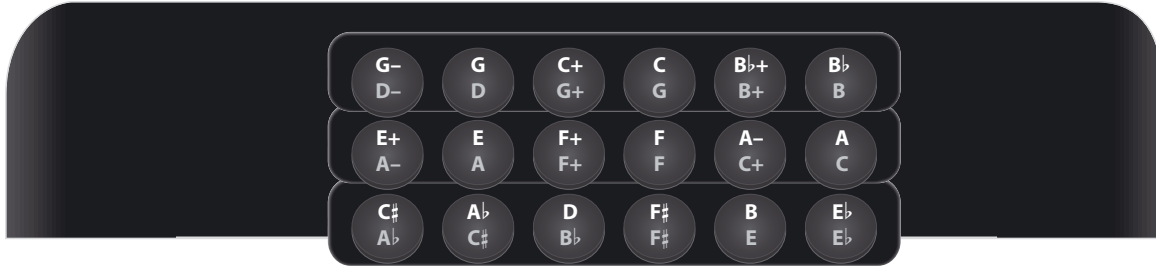
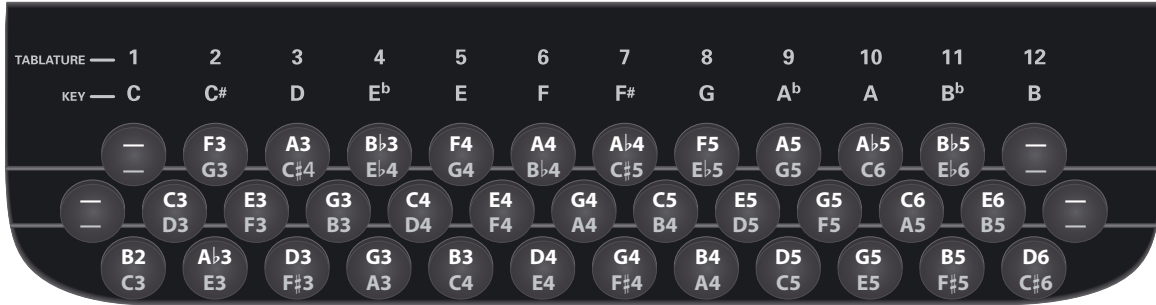

Tablature 10

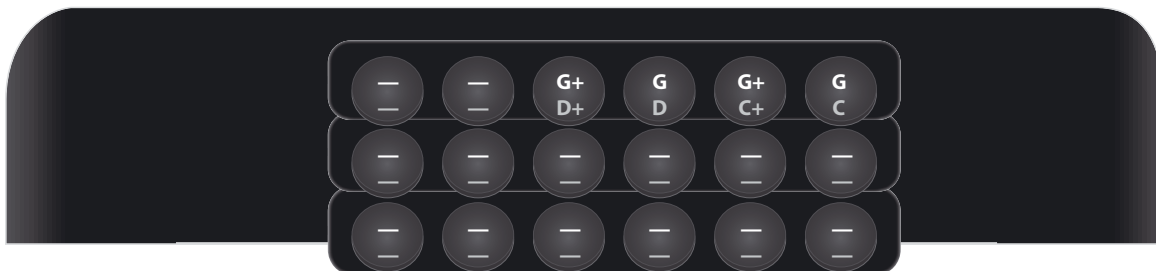
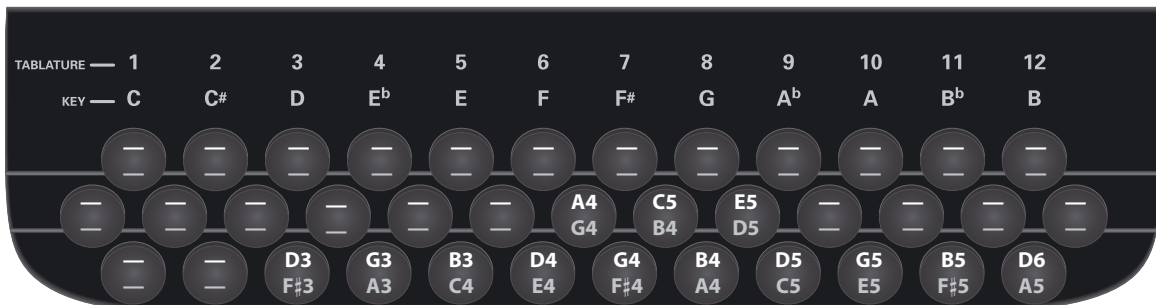

□ Closing the bellows
■ Opening the bellows

Tablature 11

TABLATURE	1	2	3	4	5	6	7	8	9	10	11	12
KEY	C	C#	D	E ^b	E	F	F#	G	A ^b	A	B ^b	B
	E ^b 4 C [#] 4	C3 E3	F3 G3	A3 B ^b 3	C4 D4	F4 E4	A4 G4	C5 B ^b 4	F5 D5	A5 E5	C6 G5	—
	F [#] 3 A ^b 3	G2 B2	C3 D3	E3 F3	G3 A3	C4 B3	E4 D4	G4 F4	C5 A4	E5 B4	G5 D5	C6 F5
	C [#] 3 E ^b 3	G2 A2	B2 C3	D3 E3	F [#] 3 A3	B3 A3	D4 C4	G4 E4	F [#] 4 A4	D5 A4	G5 C5	—

G+	G	C+	C	F+	F
D+	D	G+	G	C+	C
E+	E	A+	A	B ^b +	B ^b
A-	A	D-	D	B ^b +	B ^b
—	—	—	—	—	—
—	—	—	—	—	—

Tablature 12 (key of C)

TABLATURE	1	2	3	4	5	6	7	8	9	10	11	12
KEY	C	C#	D	E ^b	E	F	F#	G	A ^b	A	B ^b	B
	F2 A2	B ^b 2 E ^b 3	D3 F3	F3 A3	B ^b 3 C4	D4 E ^b 4	F4 F4	B ^b 4 A4	D5 C5	F5 E ^b 5	B ^b 5 G5	—
	C2 E2	F2 B ^b 2	A2 C3	C3 E3	F3 G3	A3 B ^b 3	C4 C4	F4 E4	A4 G4	C5 B ^b 4	F5 C5	A5 E ^b 5
	C2 F2	E2 G2	G2 B2	C3 D3	E3 F3	G3 A3	C4 B3	E4 D4	G4 F4	C5 A4	E5 B4	G5 D5

C+	C	F+	F	B ^b +	B ^b
G+	G	C+	C	F+	F
—	G	A+	A	D+	D
—	E	D+	D	E ^b +	E ^b
—	—	—	—	—	—
—	—	—	—	—	—

□ Closing the bellows
 ■ Opening the bellows

Demo Songs

No.	SONG TITLE	PERFORMED BY
01	Flower Carpet	Danilo Di Paolonicola
02	Funny Jump	Danilo Di Paolonicola
03	Heart & Tradition	Danilo Di Paolonicola
04	Joyful Round Dance	Danilo Di Paolonicola
05	Ireland's Sky	Danilo Di Paolonicola
06	Home Fun	Danilo Di Paolonicola
07	Sunshine's Life	Danilo Di Paolonicola
08	Hidden Heart	Danilo Di Paolonicola

[*] Copyright ©2011 Roland Europe Spa. All rights reserved. Unauthorized use of the demo songs for purposes other than private enjoyment is a violation of applicable laws. The performance data of the demo songs are not transmitted via MIDI.

Sounds contained in the various Sets

The following lists show the FR-18 diatonic's internal Sets and the sounds that are available within each Set.

SET 1.1 Folk					
Register Number	Treble Registers				
	16'	8'	8'+	8'-	4'
1 (pressed once)		0	0		
1 (pressed again)	0	0	0		
2 (pressed once)	0	0			
2 (pressed again)	0	0			0
3 (pressed once)		0	0	0	
3 (pressed again)	0	0	0	0	0
4 (pressed once)		0			0
4 (pressed again)	0				0
Register Number	Orchestra				
1 (pressed once)	Strings				
1 (pressed again)	Ac. Piano				
2 (pressed once)	Oboe				
2 (pressed again)	Flute1				
3 (pressed once)	Ac. Guitar				
3 (pressed again)	Brass				
4 (pressed once)	Fat Saw Lead				
4 (pressed again)	Poly Synth				

Register Number	Orchestra Chord
1	Ac Piano
2	Str & Choir
3	Super Poly
Register Number	Orchestra Bass
1	Acoustic Bass
2	Fretless
3	Picked Bass

SET 1.2 Classic					
Register Number	Treble Registers				
	16'	8'	8'+	8'-	4'
1 (pressed once)		0	0	0	
1 (pressed again)	0		0	0	
2 (pressed once)	0	0			0
2 (pressed again)	0				
3 (pressed once)		0			
3 (pressed again)					0
4 (pressed once)			0	0	
4 (pressed again)	0	0			
Register Number	Orchestra				
1 (pressed once)	Ac. Piano				
1 (pressed again)	Steel Gtr				
2 (pressed once)	Strings				
2 (pressed again)	Brass				
3 (pressed once)	Alto Sax				
3 (pressed again)	Tenor Sax1				
4 (pressed once)	Clarinet				
4 (pressed again)	Flute1				
Register Number	Orchestra Chord				
1	GTR Chord				
2	Ac. Piano				
3	Str & Choir				
Register Number	Orchestra Bass				
1	Finger Bass				
2	Tuba				
3	Bass & Lead				

SET 1.3 Tradition					
Register Number	Treble Registers				
	16'	8'	8'+	8'-	4'
1 (pressed once)	0		0	0	0
1 (pressed again)	0		0	0	
2 (pressed once)		0			
2 (pressed again)		0	0	0	
3 (pressed once)		0			0
3 (pressed again)			0	0	
4 (pressed once)	0	0			
4 (pressed again)	0				
Register Number	Orchestra				
1 (pressed once)	Harmonica				
1 (pressed again)	Mandolin				
2 (pressed once)	Banjo				
2 (pressed again)	Harpsi Str				
3 (pressed once)	Zampogna				
3 (pressed again)	Whistle				
4 (pressed once)	Panflute				
4 (pressed again)	Ocarina				
Register Number	Orchestra Chord				
1	Bouzouki				
2	Harpsi Str				
3	GTR Chord				
Register Number	Orchestra Bass				
1	Acoustic Bass				
2	Fretless				
3	Tuba Mix				

SET 2.1 Organetto					
Register Number	Treble Registers				
	16'	8'	8'+	8'-	4'
1 (pressed once)		0			
1 (pressed again)		0	0		
2 (pressed once)		0			0
2 (pressed again)	0	0			
3 (pressed once)	0	0			0
3 (pressed again)	0	0	0		
4 (pressed once)	0				0
4 (pressed again)		0	0		0

Register Number	Orchestra
1 (pressed once)	Harmonica
1 (pressed again)	Mandolin
2 (pressed once)	Banjo
2 (pressed again)	Bouzouki
3 (pressed once)	Whistle
3 (pressed again)	Zampogna
4 (pressed once)	Violin
4 (pressed again)	Trumpet
Register Number	Orchestra Chord
1	GTR Chord
2	Strings
3	Ac.Piano
Register Number	Orchestra Bass
1	Acous Bs
2	Bowed
3	Ac.Piano

SET 2.2 Diatonic					
Register Number	Treble Registers				
	16'	8'	8'+	8'-	4'
1 (pressed once)		0			
1 (pressed again)		0	0		
2 (pressed once)		0	0	0	
2 (pressed again)		0	0	0	0
3 (pressed once)	0	0	0	0	0
3 (pressed again)	0	0	0		
4 (pressed once)	0	0	0	0	
4 (pressed again)	0	0	0		0
Register Number	Orchestra				
1 (pressed once)	El.Piano				
1 (pressed again)	Vibe				
2 (pressed once)	Alto Sax				
2 (pressed again)	Clav2				
3 (pressed once)	Xylophone				
3 (pressed again)	Twin Trump				
4 (pressed once)	Mute Harm				
4 (pressed again)	Steel Gtr				

Register Number	Orchestra Chord
1	Oct.Piano
2	Vibe
3	80s PolySy
Register Number	Orchestra Bass
1	Fretless
2	Finger Bs
3	Rubb Bs

SET 2.3 SP Folk					
Register Number	Treble Registers				
	16'	8'	8'+	8'-	4'
1 (pressed once)	0				
1 (pressed again)	0	0			
2 (pressed once)	0	0	0		0
2 (pressed again)		0	0		0
3 (pressed once)		0			
3 (pressed again)		0	0	0	
4 (pressed once)		0	0		
4 (pressed again)	0	0	0		
Register Number	Orchestra				
1 (pressed once)	Strings				
1 (pressed again)	Clarinet				
2 (pressed once)	80s PolySy				
2 (pressed again)	El. Piano				
3 (pressed once)	Vibe				
3 (pressed again)	Ocarina				
4 (pressed once)	Kanoun				
4 (pressed again)	Bouzouki				
Register Number	Orchestra Chord				
1	Strings				
2	Ac. Piano				
3	Steel Gtr2				
Register Number	Orchestra Bass				
1	Acoustic Bass				
2	Finger Bass				
3	Tuba Mix				

SET 3.1 Alpine					
Register Number	Treble Registers				
	16'	8'	8'+	8'-	4'
1 (pressed once)	0				
1 (pressed again)	0	0			
2 (pressed once)	0				0
2 (pressed again)	0	0	0	0	0
3 (pressed once)		0	0		
3 (pressed again)		0	0	0	
4 (pressed once)		0		0	
4 (pressed again)		0	0	0	0
Register Number	Orchestra				
1 (pressed once)	Brass				
1 (pressed again)	Trumpet				
2 (pressed once)	Twin Trumpet				
2 (pressed again)	Trombone				
3 (pressed once)	Alt Sax				
3 (pressed again)	Tenor Sax1				
4 (pressed once)	Tenor Sax2				
4 (pressed again)	Clarinet				
Register Number	Orchestra Chord				
1	GTR Chord				
2	Banjo				
3	El. Piano				
Register Number	Orchestra Bass				
1	Acous. Bass				
2	Finger Bass				
3	Tuba Mix				

SET 3.2 Cajun					
Register Number	Treble Registers				
	16'	8'	8'+	8'-	4'
1 (pressed once)	0				
1 (pressed again)	0				0
2 (pressed once)	0	0	0		
2 (pressed again)		0	0		
3 (pressed once)		0	0	0	
3 (pressed again)			0	0	
4 (pressed once)		0			
4 (pressed again)					0

Register Number	Orchestra
1 (pressed once)	Trumpet
1 (pressed again)	Clarinet
2 (pressed once)	Harmonica
2 (pressed again)	Flute 1
3 (pressed once)	TW Upper
3 (pressed again)	Mandolin
4 (pressed once)	Ac.Guitar
4 (pressed again)	Ac. Piano
Register Number	Orchestra Chord
1	Ac. Guitar
2	TW Lower
3	Clarinet
Register Number	Orchestra Bass
1	Acoustic Bass
2	Finger Bass
3	Tuba

SET 3.3 Tex Mex

Register Number	Treble Registers				
	16'	8'	8'+	8'-	4'
1 (pressed once)					0
1 (pressed again)			0	0	
2 (pressed once)		0	0	0	
2 (pressed again)	0	0			
3 (pressed once)			0		
3 (pressed again)				0	0
4 (pressed once)		0			
4 (pressed again)		0	0		
Register Number	Orchestra				
1 (pressed once)	Violin				
1 (pressed again)	Twin Trump				
2 (pressed once)	Horn & Orc				
2 (pressed again)	Highland				
3 (pressed once)	Phase Clav				
3 (pressed again)	Harp St				
4 (pressed once)	Nylon & Steel				
4 (pressed again)	80s PolySy				

Register Number	Orchestra Chord
1	Str & Choir
2	Xylophone
3	FM Ep26 A
Register Number	Orchestra Bass
1	Picked Bs
2	Tuba Mix
3	Bass & Lead

SET 4.1 User Set1 (Bandoneon)

Register Number	Treble Registers				
	16'	8'	8'+	8'-	4'
1 (pressed once)		0			
1 (pressed again)					0
2 (pressed once)	0				
2 (pressed again)		0	0		0
3 (pressed once)	0	0			
3 (pressed again)	0				0
4 (pressed once)		0	0		
4 (pressed again)		0	0	0	
Register Number	Orchestra				
1 (pressed once)	Ac. Guitar				
1 (pressed again)	Mandolin				
2 (pressed once)	Banjo				
2 (pressed again)	Finger Bass				
3 (pressed once)	HarpsiStr				
3 (pressed again)	Ocarina				
4 (pressed once)	Xylophone				
4 (pressed again)	Tenor Sax1				
Register Number	Orchestra Chord				
1	Ac. Guitar				
2	Ac. Piano				
3	Banjo				
Register Number	Orchestra Bass				
1	Tuba				
2	Finger Bass				
3	Fretless				

SET 4.2 User Set2 (D-Folk)					
Register Number	Treble Registers				
	16'	8'	8'+	8'-	4'
1 (pressed once)	0				
1 (pressed again)	0	0			
2 (pressed once)	0				0
2 (pressed again)	0	0	0	0	0
3 (pressed once)		0	0		
3 (pressed again)		0	0	0	
4 (pressed once)		0		0	
4 (pressed again)		0	0	0	0
Register Number	Orchestra				
1 (pressed once)	French Horn				
1 (pressed again)	Horn & Orchestra				
2 (pressed once)	Vibe				
2 (pressed again)	Flute1				
3 (pressed once)	PanFlute				
3 (pressed again)	Violin				
4 (pressed once)	Strings				
4 (pressed again)	Sl. Strings				
Register Number	Orchestra Chord				
1	GTR Chord				
2	Xylophone				
3	Ac. Piano				
Register Number	Orchestra Bass				
1	Acoustic Bass				
2	Finger Bass				
3	Bowed				

SET 4.3 User Set3 (Concertina)					
Register Number	Treble Registers				
	16'	8'	8'+	8'-	4'
1 (pressed once)					0
1 (pressed again)		0			
2 (pressed once)		0			0
2 (pressed again)	0	0			
3 (pressed once)	0	0			0
3 (pressed again)	0				
4 (pressed once)	0		0	0	
4 (pressed again)			0	0	

Register Number	Orchestra
1 (pressed once)	El. Piano
1 (pressed again)	Xylophone
2 (pressed once)	Nylon & Steel
2 (pressed again)	Strings
3 (pressed once)	Alto Sax
3 (pressed again)	Clarinet
4 (pressed once)	Oboe
4 (pressed again)	Violin
Register Number	Orchestra Chord
1	Ac. Piano
2	Strings
3	GTR Chord
Register Number	Orchestra Bass
1	Ac. Piano
2	Acoustic Bass
3	Fretless

Program Change numbers

Below please find the program change numbers for the FR-18 diatonic's Sets and registers.

Bank Select		Program Change	Set
MSB CC00	LSB CC32		
--	--	1	1.1 Folk
--	--	2	1.2 Classic
--	--	3	1.3 Tradition
--	--	4	2.1 Organetto
--	--	5	2.2 Diatonic Folk
--	--	6	2.3 SP Folk
--	--	7	3.1 Alpine
--	--	8	3.2 Cajun
--	--	9	3.3 Tex Mex
--	--	10	4.1 User Set 1 (Bandoneon)
--	--	11	4.2 User Set 2 (D-Folk)
--	--	12	4.3 User Set 3 (Concertina)

Bank Select and Program Change RX/TX

Bank Select		Program Change	Section
MSB CC00	LSB CC32		
0	0	1~8	Treble Registers
0	0	1~3	Bass Registers
0	0	1~3	Orch Bass Registers
0	0	1~3	Orch Chord Registers
0	0	1~8	Orchestra Registers
0	0	9~16	Organ Registers
0	0	1~12	Sets

MIDI Implementation Chart

[V-Accordion]

Model: FR-18 diatonic

Date: December 2010

Version: 1.00

Function...	Transmitted	Recognized	Remarks
Basic Channel Default Changed	1~16, Off 1~16, Off	1~16, Off 1~16, Off	7 Parts: 1= Treble, 2= Bass, 3= Chord, 4= Orchestra/Organ, 5= Orchestra Bass, 6= Orchestra Chord, 10= Drums, 1 Logical part: 13= Basic MIDI Channel for SET change
Mode Default Message Altered	Mode 3 ***** *****	Mode 3 *****	
Note Number True Voice	18~124 *****	0~127 0~127	
Velocity Note ON Note OFF	O O	O O	
After Touch Key's Ch's	X X	X X	
Pitch Bend	X	X	
Control Change	00,32 O 07 O 10 O 11 O *1 64 X 91 O 93 O	O X X O X X X	Bank Select Volume Panpot Expression Hold 1 Reverb Send Chorus Send
Program Change True #	O *1 1~16	O 1~16	Recognized: 1~16: 1~8: Treble Registers 1~3 Bass & chord registers 1~3 Orchestra Bass registers 1~3 Orchestra Chord registers 1~16 Orchestra/Organ registers 1~12 Set
System Exclusive	X	X	
System Common Song Position Pointer Song Sel Tune	X X X	X X X	
System Real Time Clock Commands	X X	X X	
Aux Messages All Sounds Off Reset All Controllers Local On/Off All Notes Off Active Sense Reset	X X X X O X	X X X X O X	
Notes	*1 O X is selectable		

Mode 1: OMNI ON, POLY
Mode 3: OMNI OFF, POLY

Mode 2: OMNI ON, MONO
Mode 4: OMNI OFF, MONO

O: Yes
X: No

Information

When you need repair service, call your nearest Roland Service Center or authorized Roland distributor in your country as shown below.

AFRICA

EGYPT

Al Fanny Trading Office
9, EBN Hagar Al Askalany Street,
ARD E1 Golf, Heliopolis,
Cairo 11341, EGYPT
TEL: (022)-417-1828

REUNION

MARCEL FO-YAM Sarl
25 Rue Jules Hermann,
Chaudron - BP79 97 491
Ste Clotilde Cedex,
REUNION ISLAND
TEL: (0262) 218-429

SOUTH AFRICA

T.O.M.S. Sound & Music (Pty)Ltd.
2 ASTRON ROAD DENVER
JOHANNESBURG ZA 2195,
SOUTH AFRICA
TEL: (011) 417 3400

Paul Bothner(PTY)Ltd.
Royal Cape Park, Unit 24
Londonderry Road, Ottery 7800
Cape Town, SOUTH AFRICA
TEL: (021) 799 4900

ASIA

CHINA

Roland Shanghai Electronics Co.,Ltd.
5F.No.1500 Pingliang Road
Shanghai 200090, CHINA
TEL: (021) 5580-0800

Roland Shanghai Electronics Co.,Ltd. (BEIJING OFFICE)
3F, Soluxe Fortune Building
63 West Dawang Road, Chaoyang
District, Beijing, CHINA
TEL: (010) 5960-2565

HONG KONG

Tom Lee Music
11/F Silvercord Tower 1
30 Canton Rd
Tsimshatsui, Kowloon,
HONG KONG
TEL: 852-2737-7688

Parsons Music Ltd.
8th Floor, Railway Plaza, 39
Chatham Road South, T.S.T,
Kowloon, HONG KONG
TEL: 852-2333-1863

INDIA

Rivera Digitec (India) Pvt. Ltd.
411, Nirman Kendra Mahalaxmi
Flats Compound Off. Dr. Edwin
Moses Road, Mumbai-400011,
INDIA
TEL: (022) 2493 9051

INDONESIA

PT. Citra Intirama
Ruko Garden Shopping Arcade
Unit 8 CR, Podomoro City
JL.Letjend. S.Parman Kav.28
Jakarta Barat 11470, INDONESIA
TEL: (021) 5698-5519/5520

KOREA

Cosmos Corporation
1461-9, Seocho-Dong,
Seocho Ku, Seoul, KOREA
TEL: (02) 3486-8855

MALAYSIA/ SINGAPORE

Roland Asia Pacific Sdn. Bhd.
45-1, Block C2, Jalan PJU 1/39,
Dataran Prima, 47301 Petaling
Jaya, Selangor, MALAYSIA
TEL: (03) 7805-3263

PHILIPPINES

G.A. Yupangco & Co. Inc.
339 Gill J. Puyat Avenue
Makati, Metro Manila 1200,
PHILIPPINES
TEL: (02) 899 9801

TAIWAN

ROLAND TAIWAN ENTERPRISE CO., LTD.
9F-5, No. 112 Chung Shan
North Road Sec. 2 Taipei 104,
TAIWAN R.O.C.
TEL: (02) 2561 3339

THAILAND

Theera Music Co., Ltd.
100-108 Soi Verng Nakornkasem,
New Road,Sumpantawong,
Bangkok 10100, THAILAND
TEL: (02) 224-8821

VIET NAM

HIET THUONG CORPORATION
386 CACH MANG THANG TAM ST.
DIST.3, HO CHI MINH CITY,
VIET NAM
TEL: (08) 9316540

OCEANIA

AUSTRALIA/ NEW ZEALAND

Roland Corporation Australia Pty.,Ltd.
38 Campbell Avenue
Dee Why West. NSW 2099,
AUSTRALIA

For Australia
TEL: (02) 9982 8266
For New Zealand
TEL: (09) 3098 715

CENTRAL/LATIN AMERICA

ARGENTINA

Instrumentos Musicales S.A.
Av.Santa Fe 2055
(1123) Buenos Aires, ARGENTINA
TEL: (011) 4508-2700

BARBADOS

A&B Music Supplies LTD
122 Webster Industrial Park
Wildely, St.Michael, BARBADOS
TEL: (246) 430-1100

BRAZIL

Roland Brasil Ltda.
Rua San Jose, 211
Parque Industrial San Jose
Cotia - Sao Paulo - SP, BRAZIL
TEL: (011) 4615 5666

CHILE

Comercial Fancy II S.A.
Rut.: 96.919.420-1
Nataliel Cox #739, 4th Floor
Santiago - Centro, CHILE
TEL: (02) 688-9540

COLOMBIA

Centro Musical Ltda.
Cra 43 B No 25 A 41 Bododega 3
Medellin, COLOMBIA
TEL: (574) 3812529

COSTA RICA

JUAN Ransbach Instrumentos Musicales
Ave.1. Calle 11, Apartado 10237,
San Jose, COSTA RICA
TEL: 258-0211

CURACAO

Zeelandia Music Center Inc.
Orionweg 30
Curacao, Netherland Antilles
TEL: (305) 5926866

DOMINICAN REPUBLIC

Instrumentos Fernando Giraldez
Calle Proyecto Central No.3
Ens.La Esperilla
Santo Domingo,
DOMINICAN REPUBLIC
TEL: (809) 683 0305

ECUADOR

Mas Musica
Rumichaca 822 y Zaruma
Guayaquil - ECUADOR
TEL: (593-4) 2302364

EL SALVADOR

OMNI MUSIC
75 Avenida Norte y Final Alameda
Juan Pablo II,
Edificio No.4010 San Salvador,
EL SALVADOR
TEL: 262-0788

GUATEMALA

Casa Instrumental
Calzada Roosevelt 34-01,zona 11
Ciudad de Guatemala,
GUATEMALA
TEL: (502) 599-2888

HONDURAS

Alman Pajaro Azul S.A. de C.V.
BO.Paz Barahona
3 Ave.11 Calle S.O
San Pedro Sula, HONDURAS
TEL: (504) 553-2029

MARTINIQUE

Musique & Son
Z.I.Les Mangle
97232 Le Lamantin,
MARTINIQUE F.W.I.
TEL: 596 596 426860

Gigamus SARL

10 Rte De La Folie
97200 Fort De France
MARTINIQUE F.W.I.
TEL: 596 596 715222

MEXICO

Casa Veerkamp, s.a. de c.v.
Av. Toluca No. 323, Col. Olivar
de los Padres 01780 Mexico D.F.,
MEXICO
TEL: (55) 5668-6699

NICARAGUA

Bansbach Instrumentos Musicales Nicaragua
Altamira D'Este Calle Principal
de la Farmacia Sta.Avenida
1 Cuadra al Lago.#503
Managua, NICARAGUA
TEL: (505) 277-2557

PANAMA

SUPRO MUNDIAL, S.A.
Boulevard Andrews, Albrook,
Panama City, REP. DE PANAMA
TEL: 315-0101

PARAGUAY

Distribuidora De Instrumentos Musicales
J.E. Olear y ESQ. Manduvira
Asuncion, PARAGUAY
TEL: (595) 21 492147

PERU

Audionet
Distribuciones Musicales SAC
Juan Fanning 530
Miraflores
Lima - PERU
TEL: (511) 4461388

TRINIDAD

AMR Ltd
Ground Floor
Maritime Plaza
Barataria TRINIDAD W.I.
TEL: (868) 638 6385

URUGUAY

Todo Musica S.A.
Francisco Acuna de Figueroa
1771
C.P.: 11.800
Montevideo, URUGUAY
TEL: (02) 924-2335

VENEZUELA

Instrumentos Musicales Allegro,C.A.
Av.las industrias edf.Guitar import
#7 zona Industrial de Turumo
Caracas, VENEZUELA
TEL: (212) 244-1122

EUROPE

BELGIUM/FRANCE/ HOLLAND/ LUXEMBOURG

Roland Central Europe N.V.
Houtstraat 3, B-2260, Oevel
(Westerlo) BELGIUM
TEL: (014) 575811

CROATIA

ART-CENTAR
Degenova 3,
HR - 10000 Zagreb, CROATIA
TEL: (1) 466 8493

CZECH REP.

CZECH REPUBLIC DISTRIBUTOR s.r.o
Voctárova 247/16
180 00 Praha 8, CZECH REP.
TEL: (2) 830 20270

DENMARK

Roland Scandinavia A/S
Skagerrakvej 7 Postbox 880
DK-2100 Copenhagen,
DENMARK
TEL: 3916 6200

FINLAND

Roland Scandinavia As, Filial Finland
Vanha Nurmijarventie 62
01670 Vantaa, FINLAND
TEL: (0) 9 68 24 020

GERMANY/AUSTRIA

Roland Elektronische Musikinstrumente HmbH.
Oststrasse 96, 22844 Norderstedt,
GERMANY
TEL: (040) 52 60090

GREECE/CYPRUS

STOLLAS S.A.
Music Sound Light
155, New National Road
Patras 26442, GREECE
TEL: 2610 435400

HUNGARY

Roland East Europe Ltd.
2045 Torokbalint, FSD Park,
building 3., HUNGARY
TEL: (23) 511011

IRELAND

Roland Ireland
E2 Calmount Park, Calmount
Avenue, Dublin 12,
Republic of IRELAND
TEL: (01) 4294444

ITALY

Roland Italy S. p. A.
Viale delle Industrie 8,
20020 Arese, Milano, ITALY
TEL: (02) 937-78300

NORWAY

Roland Scandinavia Avd. Kontor Norge
Lilleakerveien 2 Postboks 95
Lilleaker N-0216 Oslo,
NORWAY
TEL: 2273 0074

POLAND

ROLAND POLSKA SP. Z O.O.
ul. Kty Grodziskie 16B
03-289 Warszawa, POLAND
TEL: (022) 678 9512

PORTUGAL

Roland Iberia, S.L.
Branch Office Porto
Edificio Tower Plaza
Rotunda Eng. Edgar Cardoso
23, 9ºG
4400-676 Vila Nova de Gaia,
PORTUGAL
TEL: (+351) 22 608 00 60

ROMANIA

FBS LINES
Piata Libertatii 1,
535500 Gheorgheni, ROMANIA
TEL: (266) 364 609

RUSSIA

Roland Music LLC
Dorozhnaya ul.3,korp.6
117 545 Moscow, RUSSIA
TEL: (495) 981-4967

SERBIA

Music AP Ltd.
Sutjeska br. 5 XS - 24413 Palic,
SERBIA
TEL: (024) 539 395

SLOVAKIA

DAN Acoustic s.r.o.
Povazská 18,
SK - 940 01 Nové Zámky,
SLOVAKIA
TEL: (035) 6424 330

SPAIN

Roland Iberia, S.L.
Paseo García Faria, 33-35
08005 Barcelona, SPAIN
TEL: 93 493 91 00

SWEDEN

Roland Scandinavia A/S
SWEDISH SALES OFFICE
Mårbackagatan 31, 4 tr.
SE-123 43 Farsta, SWEDEN
TEL: (0) 8 683 04 30

SWITZERLAND

Roland (Switzerland) AG
Landstrasse 5, Postfach,
CH-4452 Itingen, SWITZERLAND
TEL: (061) 975-9987

UKRAINE

EURHYTHMICS Ltd.
P.O.Box: 37-a,
Nedecey Str. 30
UA - 89600 Mukachevo, UKRAINE
TEL: (03131) 414-40

UNITED KINGDOM

Roland (U.K.) Ltd.
Atlantic Close, SWANSEA SA7 9FJ,
UNITED KINGDOM
TEL: (01792) 702701

MIDDLE EAST

BAHRAIN

Moon Stores
No.1231&1249 Rumaytha
Building Road 3931,
Manama 339, BAHRAIN
TEL: 17 813 942

IRAN

MOCO INC.
NO.16 End of Nike St. Shariaty
Ave, Roberouye Cerah Mirdamad
Teheran, IRAN
TEL: (021)-2288-2998

ISRAEL

Halilit P. Greenspoon & Sons Ltd.
8 Retzif Ha'alial Hashnha St.
Tel-Aviv-Yafo ISRAEL
TEL: (03) 6823666

JORDAN

MUSIC HOUSE CO. LTD.
FREDDY FOR MUSIC
P. O. Box 922846
Amman 11192, JORDAN
TEL: (06) 5692696

KUWAIT

EASA HUSAIN AL-YOUSIFI & SONS CO.
Al-Yousif Service Center
P.O.Box 126 (Safa) 13002,
KUWAIT
TEL: 00 965 802929

LEBANON

Chahine S.A.L.
George Zeidan St., Chahine Bldg.,
Achrafieh, P.O.Box: 16-5857
Beirut, LEBANON
TEL: (01) 20-1441

OMAN

TALENTZ CENTRE L.L.C.
Malatan House No.1
Al Noor Street, Ruwi
SULTANATE OF OMAN
TEL: 2478 3443

QATAR

AL-EMADI TRADING & CONTRACTING CO.
P.O. Box 62, Doha, QATAR
TEL: 4423-554

SAUDI ARABIA

aDawlah Universal Electronics APL
Behind Pizza Inn
Prince Turkey Street
aDawlah Building,
PO BOX 2154,
Alkhorar 31952,
SAUDI ARABIA
TEL: (03) 8643601

SYRIA

Technical Light & Sound Center
PO Box 13520 Bldg No.49
Khaled Abn Alwalid St.
Damascus, SYRIA
TEL: (011) 223-5384

TURKEY

ZUHAL DIS TICARET A.S.
Galip Dede Cad. No.33
Beyoglu, Istanbul, TURKEY
TEL: (0212) 249 85 10

U.A.E.

Zak Electronics & Musical Instruments Co. L.L.C.
Khaled Road, Al Sherouq Bldg.,
No. 14, Ground Floor, Dubai,
U.A.E.
TEL: (04) 3360715

NORTH AMERICA

CANADA

Roland Canada Ltd. (Head Office)
5480 Parkwood Way Richmond B.
C., V6V 2M4, CANADA
TEL: (604) 270 6626

Roland Canada Ltd. (Toronto Office)

170 Admiral Boulevard
Mississauga On L5T 2N6,
CANADA
TEL: (905) 362 9707

U. S. A.

Roland Corporation U.S.
5100 S. Eastern Avenue
Los Angeles, CA 90040-2938,
U. S. A.
TEL: (323) 890 3700

MEMO

17. Index

A	
Adapter	19
Adaptor	15
Alpine	34
American	34
Auto Power Off	46
B	
Balance	31
Basic channel	49
Bass	27
Off	30
Using	27
Bass Button Noise	46
Bass strap	18
Batteries	9, 16, 34
Installing	16
Bellows	
Resistance regulator	11
Bellows Curve	45
Button Noise	46
C	
Chord	27, 47
Off	30
Chorus	44
Classic	34
Connections	17
D	
Decoration	20
Default	32
Delay	44
Demo songs	23
Detune	34
D-Folk	34
Driver	46, 48
Drumming	30
Drums	30
Dry	34
Dual	26
E	
Editing	41
Effects	32, 44
Expansion	39
F	
Factory Setup	51
F-Folk	34
Flanger	45
French	34
Function	41
G	
German	34
H	
Hall	44
Headphones	21
I	
Initialize	51
Italian	34
K	
Key	32, 33
L	
Left hand	27
Left Register	29
Level	21
M	
Master Tune	43
Memories	35
Memorize	35
Metronome	44
MIDI	47
Channels	47
Parameters	48
USB	48
Musette Detune	34
Musical key	32
Mute	30
N	
North Eur	34
O	
OCT	27
Orch	
Bass	29
Chord	29
Orchestral sounds	
Bass and chord	28
Treble	25
Organ	25
P	
Pan Delay	44
Percussion	30
Personalize	20
Phones	21
Plate	44
Power on/off	21
R	
Register	
Colors	25
Resetting	51
Resistance regulator	11
Reverb	44
Room	44
S	
Save	35
Scottish	34
Sections	11
Sets	24
Program change	49
Shift	27
Solo	26
Sounds	25
Left hand	27
Specifications	53
Straps	17
Switching on/off	21
T	
Tablature	33, 39
Trafofo	20
Transpose	27
Treble	
Off	30
Using	25
Valve Noise	45
U	
USB	37, 48
Driver	46, 48
MIDI	48
User Program	35, 38
User Set	38
V	
Valve Noise	45
Volume	21
Headphones	21
W	
Write	35

Roland

70



60200046201

For EU countries



- UK** This symbol indicates that in EU countries, this product must be collected separately from household waste, as defined in each region. Products bearing this symbol must not be discarded together with household waste.
- DE** Dieses Symbol bedeutet, dass dieses Produkt in EU-Ländern getrennt vom Hausmüll gesammelt werden muss gemäß den regionalen Bestimmungen. Mit diesem Symbol gekennzeichnete Produkte dürfen nicht zusammen mit dem Hausmüll entsorgt werden.
- FR** Ce symbole indique que dans les pays de l'Union européenne, ce produit doit être collecté séparément des ordures ménagères selon les directives en vigueur dans chacun de ces pays. Les produits portant ce symbole ne doivent pas être mis au rebut avec les ordures ménagères.
- IT** Questo simbolo indica che nei paesi della Comunità europea questo prodotto deve essere smaltito separatamente dai normali rifiuti domestici, secondo la legislazione in vigore in ciascun paese. I prodotti che riportano questo simbolo non devono essere smaltiti insieme ai rifiuti domestici. Ai sensi dell'art. 13 del D.Lgs. 25 luglio 2005 n. 151.
- ES** Este símbolo indica que en los países de la Unión Europea este producto debe recogerse aparte de los residuos domésticos, tal como esté regulado en cada zona. Los productos con este símbolo no se deben depositar con los residuos domésticos.
- PT** Este símbolo indica que nos países da UE, a recolha deste produto deverá ser feita separadamente do lixo doméstico, de acordo com os regulamentos de cada região. Os produtos que apresentem este símbolo não deverão ser eliminados juntamente com o lixo doméstico.
- NL** Dit symbool geeft aan dat in landen van de EU dit product gescheiden van huishoudelijk afval moet worden aangeboden, zoals bepaald per gemeente of regio. Producten die van dit symbool zijn voorzien, mogen niet samen met huishoudelijk afval worden verwijderd.
- DK** Dette symbol angiver, at i EU-lande skal dette produkt opsamles adskilt fra husholdningsaffald, som defineret i hver enkelt region. Produkter med dette symbol må ikke smides ud sammen med husholdningsaffald.
- NO** Dette symbolet indikerer at produktet må behandles som spesialavfall i EU-land, iht. til retningslinjer for den enkelte regionen, og ikke kastes sammen med vanlig husholdningsavfall. Produkter som er merket med dette symbolet, må ikke kastes sammen med vanlig husholdningsavfall.

- SE** Symbolen anger att i EU-länder måste den här produkten kasseras separat från hushållsavfall, i enlighet med varje regions bestämmelser. Produkter med den här symbolen får inte kasseras tillsammans med hushållsavfall.
- FI** Tämä merkintä ilmaisee, että tuote on EU-maissa kerättävä erillään kotitalousjätteistä kunkin alueen voimassa olevien määräysten mukaisesti. Tällä merkinnällä varustettuja tuotteita ei saa hävittää kotitalousjätteiden mukana.
- HU** Ez a szimbólum azt jelenti, hogy az Európai Unióban ezt a terméket a háztartási hulladéktól elkülönítve, az adott régióban érvényes szabályozás szerint kell gyűjteni. Az ezzel a szimbóllummal ellátott termékeket nem szabad a háztartási hulladék közé dobni.
- PL** Symbol oznacza, że zgodnie z regulacjami w odpowiednim regionie, w krajach UE produktu nie należy wyrzucać z odpadami domowymi. Produktów opatrzonych tym symbolem nie można utylizować razem z odpadami domowymi.
- CZ** Tento symbol udává, že v zemích EU musí být tento výrobek sbírán odděleně od domácího odpadu, jak je určeno pro každý region. Výrobky nesoucí tento symbol se nesmí vyhazovat spolu s domácím odpadem.
- SK** Tento symbol vyjadruje, že v krajinách EÚ sa musí zber tohto produktu vykonávať oddelene od domového odpadu, podľa nariadení platných v konkrétnej krajine. Produkty s týmto symbolom sa nesmú vyhazovať spolu s domovým odpadom.
- EE** See sümbol näitab, et EL-i maades tuleb see toode olemprügist eraldi koguda, nii nagu on igas piirkonnas määratletud. Selle sümboliga märgitud tooteid ei tohi ära visata koos olmeprügiga.
- LT** Šis simbolis rodo, kad ES šalyse šis produktas turi būti surenkamas atskirai nuo buitinių atliekų, kaip nustatyta kiekviename regione. Šiuo simboliu paženklinoti produktai neturi būti išmetami kartu su buitiniemis atliekomis.
- LV** Šis simbols norāda, ka ES valstīs šo produktu jāievāc atsevišķi no mājstaimniecības atkritumiem, kā noteikts katrā reģionā. Produkts ar šo simbolu nedrīkst izmest kopā ar mājstaimniecības atkritumiem.
- SI** Ta simbol označuje, da je treba proizvod v državah EU zbirati ločeno od gospodinjjskih odpadkov, tako kot je določeno v vsaki regiji. Proizvoda s tem znakom ni dovoljeno odlagati skupaj z gospodinjjskimi odpadki.
- GR** Το σύμβολο αυτό υποδηλώνει ότι στις χώρες της Ε.Ε. το συγκεκριμένο προϊόν πρέπει να συλλέγεται χωριστά από τα υπόλοιπα οικιακά απορρίμματα, σύμφωνα με όσα προβλέπονται σε κάθε περιοχή. Τα προϊόντα που φέρουν το συγκεκριμένο σύμβολο δεν πρέπει να απορρίπτονται μαζί με τα οικιακά απορρίμματα.

For China

有关产品中所含有害物质的说明

本资料就本公司产品中所含的特定有害物质及其安全性予以说明。
本资料适用于 2007 年 3 月 1 日以后本公司所制造的产品。

环保使用期限



此标志适用于在中国国内销售的电子信息产品，表示环保使用期限的年数。所谓环保使用期限是指在自制造日期的规定期限内，产品中所含的有害物质不致引起环境污染，不会对人身、财产造成严重的不良影响。环保使用期限仅在遵照产品使用说明书，正确使用产品的条件下才有效。不当的使用，将会导致有害物质泄漏的危险。

产品中有毒有害物质或元素的名称及含量

部件名称	有毒有害物质或元素					
	铅(Pb)	汞(Hg)	镉(Cd)	六价铬(Cr(VI))	多溴联苯(PBB)	多溴二苯醚(PBDE)
外壳(壳体)	×	○	○	○	○	○
电子部件(印刷电路板等)	×	○	×	○	○	○
附件(电源线、交流适配器等)	×	○	○	○	○	○

○：表示该有毒有害物质在该部件所有均质材料中的含量均在 SJ/T11363-2006 标准规定的限量要求以下。
×：表示该有毒有害物质至少在该部件的某一均质材料中的含量超出 SJ/T11363-2006 标准规定的限量要求。
因根据现有的技术水平，还没有什么物质能够代替它。

For C.A. US (Proposition 65)

WARNING

This product contains chemicals known to cause cancer, birth defects and other reproductive harm, including lead.

Roland

602.00.0462.01 RES 816-10 FR-18 diatonic Owner's Manual - E

