

# ROTEL *hiFi*

## RCD-945AX STEREO COMPACT DISC PLAYER

# OWNER'S MANUAL

**WARNING**  
TO PREVENT FIRE OR SHOCK HAZARD,  
DO NOT EXPOSE THIS APPLIANCE TO  
RAIN OR MOISTURE

Write your SERIAL NUMBER here.  
The number is located near the  
identification plate on the rear panel.

## SAFETY INSTRUCTIONS

- 1. Read Instructions** - All the safety and operating instructions should be read before the appliance is operated.
- 2. Retain Instructions** - The safety and operating instructions should be retained for future reference.
- 3. Heed Warnings** - All warnings on the appliance and in the operating instructions should be adhered to.
- 4. Follow Instructions** - All operating and use instructions should be followed.
- 5. Water and Moisture** - The appliance should not be used near water - for example, near a bathtub, kitchen sink, laundry tub, in a wet basement or near a swimming pool, etc.
- 6. Carts and Stands** - The appliance should be used only with a cart or stand that is recommended by the manufacturer.
- 6A.** An appliance and cart combination should be moved with care. Quick stops, excessive force and uneven surfaces may cause the appliance and cart combination to overturn.
- 7. Wall or Ceiling Mounting** - The appliance should be mounted to a wall or ceiling only as recommended by the manufacturer.
- 8. Ventilation** - The appliance should be situated so that its location or position does not interfere with its proper ventilation. For example, the appliance should not be situated on a bed, sofa, rug, or similar surface that may block the ventilation openings; or placed in a built-in installation, such as a bookcase or cabinet that may impede the flow of air through the ventilation openings.
- 9. Heat** - The appliance should be situated away from heat sources such as radiators, heat registers, stoves or other appliances (including amplifiers) that produce heat.
- 10. Power Sources** - The appliance should be connected to a power supply only of the type described in the operating instructions or as marked on the appliance.
- 11. Grounding or Polarization** - The precautions that should be taken so that the grounding or polarization means of an appliance is not defeated.
- 12. Power-Cord Protection** - Power supply cords should be routed so that they are not likely to be walked on or pinched by items placed upon or against them, paying particular attention to cords and plugs, convenience receptacles and the point where they exit from the appliance.
- 13. Cleaning** - The appliance should be cleaned only as recommended by the manufacturer.
- 14. Nonuse Periods** - The power cord of the appliance should be unplugged from the outlet when left unused for a long period of time.
- 15. Object and Liquid Entry** - Care should be taken so that objects do not fall and liquids are not spilled into the enclosure through the openings.
- 16. Damage Requiring Service** - The appliance should be serviced by qualified factory-authorized service personnel when:
  - The power-supply cord or the plug has been damaged; or
  - Objects have fallen, or liquid has been spilled into the appliance; or
  - The appliance has been exposed to rain; or
  - The appliance does not appear to operate normally or exhibits a marked change in performance; or
  - The appliance has been dropped, or the enclosure damaged.
- 17. Servicing** - The user should not attempt to service the appliance beyond that described in the operating instructions. All other servicing should be referred to qualified factory-authorized service personnel.

PORTABLE CART  
WARNING



**WARNING:** To reduce the risk of fire or electric shock, do not expose this appliance to rain or moisture.

**DANGER:** Invisible laser radiation when you open the top cover, audio direct exposure to laser beam

**CLASS 1 Laser Product.** Complies with DHHS 21 CFR 1040.10 and 1040.11.



**CAUTION**  
RISK OF ELECTRIC SHOCK  
DO NOT OPEN



**CAUTION: TO REDUCE THE RISK OF ELECTRIC SHOCK, DO NOT REMOVE COVER (OR BACK). NO USER-SERVICEABLE PARTS INSIDE. REFER SERVICING TO QUALIFIED SERVICE PERSONNEL.**

**CAUTION:** Use of controls or adjustments, or performance of procedures other than those specified herein may result in hazardous radiation exposure.

### Explanation of Graphical Symbols

The lightning flash with arrowhead symbol, within an equilateral triangle, is intended to alert the user to the presence of uninsulated 'dangerous voltage' within the product's enclosure that may be of sufficient magnitude to constitute a risk of electric shock to persons.

The exclamation point within an equilateral triangle is intended to alert the user to the presence of important operating and maintenance instructions in the literature accompanying the appliance



**CLASS 1 LASER PRODUCT**

	Page
Introduction.....	1
Unpacking and Installing.....	1
Making the Connections .....	3
Location and Operation of Controls - Front Panel .....	4
Location and Operation of Controls - Remote Control Unit.....	8
Trouble Shooting Guide.....	8
Specifications .....	9

---

## **INTRODUCTION**

---

### A WORD FROM ROTEL

We at Rotel take this opportunity to thank you for choosing our product. Our commitment and dedication to the design and manufacturing of high fidelity products for more than thirty years have guided the creation of equipment with the highest level in sound reproduction. We are confident that you will enjoy your Rotel equipment, now and for many years to come.

Please read this instruction manual carefully before you start using your compact disc player and keep it in a safe place for future reference. Thank you.

### INTRODUCING THE RCD-945AX COMPACT DISC (CD) PLAYER

The RCD-945AX is an entry level CD player, combining easy-to-operate controls with several advanced circuit-design features. The player has an all-metal cabinet with aluminum front panel, which gives the player a rigid and solid construction, contributing to its performance and reliability.

The player's disc drive is based on the single beam swing-arm technology. The swing-arm is mounted on specially designed ball pivot bearings and direct-driven by a linear motor. This, together with its servo system, provides fast access and excellent tracking accuracy.

Digital to analog conversion is performed using Bitstream technology, which significantly improves small signal reproduction, giving the player its characteristically rich sound quality. A coaxial digital output is also provided for direct connection to a digital amplifier or digital audio processor.

The RCD-945AX has all the conventional CD player operating controls and several extra features for added user convenience. The repeat function has a dual utility, providing 'whole disc' and 'single track' repeat. The scan function plays the first 10 seconds of each track and the A<>B function repeats a passage between any two points on a disc. The random function plays tracks in a non-sequential order and the time function provides elapsed and remaining time readouts. The program function allows programming of 20 tracks in any sequence and provides correction and review facilities. The RCD-945AX comes with a remote control unit that duplicates all front panel controls and has an added 10-key pad for direct track access.

---

## **UNPACKING AND INSTALLING**

---

### CONTENTS OF THE PACKAGING BOX

- RCD-945AX compact disc player
- RR-903 remote control unit and batteries
- Interconnect cable
- Instruction manual

If any of these items is missing, please contact your dealer immediately.

### UNPACKING

Carefully unpack your CD player and place it gently at its intended location. Please keep the packaging material for future use in case you move or need to return the unit for service.

## TRANSPORT KEYS

To protect the internal mechanism of your player from excessive shock during transit, it has been secured by two transport keys. These transport keys are located on the bottom of the unit, as shown. Before you use your player, be sure to remove them as follows:

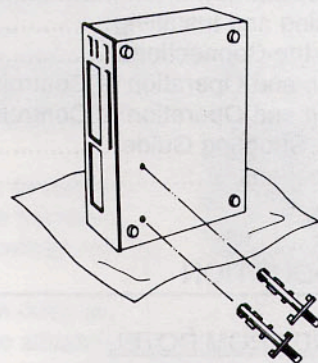

- Carefully place the unit on its left side. Do not subject it to any shocks.
- Rotate the transport keys a quarter turn counter-clockwise and pull them out.
- Place the transport keys in a safe place, as you may need them in the future.
- If you are going to transport your player, be sure to re-insert the transport keys by reversing the previous instructions. Ensure there is no disc in the tray when you put the keys back in.

## LOCATION

- Place the player on a flat, firm surface where it will be free from direct sunlight, excessive humidity, vibrations, dust, heat or cold.
- Do not place audio or video cassettes on top of the player because their content may be erased due to the magnetic fields created by the transformer in the player.
- Never place the player on top of an amplifier. This could block the amplifier's ventilation outlet and damage the equipment by overheating.

## INTERFERENCE

CD players can cause interference to certain equipment such as tuners or receivers. One or a combination of the following measures may be required to eliminate this interference:

- Increase the distance between the player and the tuner (or other apparatus).
- In the case of a tuner or receiver, reorient or relocate the antenna, or use an outdoor antenna.
- Connect the player into a AC (mains) outlet circuit different to that which the other apparatus is connected.
- Contact your dealer for further advice.

## ELECTRICAL REQUIREMENTS

Your equipment has been designed to be powered by your local AC (mains) supply. Before connecting it to the AC (mains) outlet, check the rating of your unit at the identification plate located on the rear panel of the unit on the top right-hand side. Never plug the unit into an outlet of voltage different to that specified. The wrong voltage can cause a serious fire hazard. Consult your dealer if in doubt.

**EXCLUSIVE NOTE FOR U.K.** - If your unit comes with a 2-core mains lead without a plug, neither core is to be connected to the earth terminal of a three pin plug, make certain they are connected according to the following instruction, to the proper terminals. Check that the terminals are screwed down firmly and no loose strands of wire are present. **IMPORTANT:** The wires in the mains lead are coloured in accordance with the following code:

**BLUE = NEUTRAL / BROWN = LIVE**

As the colours of the wires in the mains lead of this apparatus may not correspond with the coloured markings identifying the terminals in your plug, proceed as follows: The wire which is coloured BLUE must be connected to the terminal which is marked with the letter N or coloured BLUE or BLACK. The wire which is coloured BROWN must be connected to the terminal which is marked with the letter L or coloured BROWN or RED.

## THE CABINET

There are no user-serviceable parts inside the unit. Do not attempt to open the cabinet, as this could damage your unit and void your warranty. If the player is dropped, damaged or does not seem to function properly, disconnect the power cord immediately and consult your dealer. If your unit becomes dirty, wipe it gently with a soft, clean, dry cloth. Never use solvents of any kind. To ensure the internal mechanism is kept free from dust and dirt, do not forget to close the disc tray.

## TROUBLESHOOTING GUIDE

Please ensure you read the Troubleshooting Guide on common operating errors, before concluding that the player needs servicing.

## REMOTE CONTROL UNIT

Lift the battery cover out - on the back of the remote control unit - and insert the two batteries in the correct position, as indicated. Push the cover back in to secure the batteries properly. The remote control unit should be pointed toward the player, to activate the functions. The average lifetime of the batteries is approximately one year, but may vary with the intensity of usage. To ensure the proper safe-keeping of the remote control unit:

- Keep the remote control unit away from extremely hot or humid places.
- Avoid dropping and spilling liquids on or into the remote control unit.
- Avoid exposing the remote sensor to direct sunlight or lighting apparatus.
- Remove the batteries when the remote control unit will not be used for a long time, to avoid leakage of the batteries, as this could damage your unit.

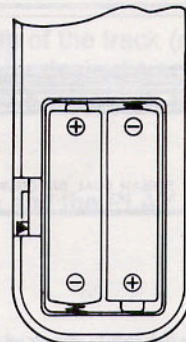

## MAKING THE CONNECTIONS

**NOTE:** Ensure the power is turned off and that the power cords from the equipment have been unplugged from the AC (mains) outlet before making any connections.

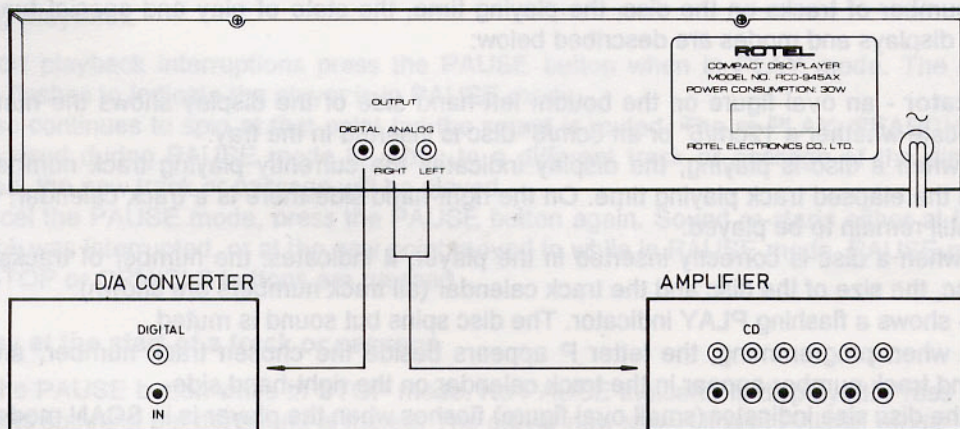

### 1. CONNECTING TO AN INTEGRATED AMPLIFIER OR PREAMPLIFIER

Connect the ANALOG OUTPUT jacks (1) (RCA jacks) on the back of the player, to the CD input jacks of your amplifier, using the interconnect cord supplied. Make sure the right (RED) and the left (WHITE) channels are correctly connected to the corresponding inputs on your amplifier. You may also connect the player to the AUX inputs on your amplifier if the CD input is already being used by another player, or if there is no CD input available.

### 2. CONNECTING TO A SEPARATE D/A CONVERTER

If you have a separate D/A converter unit or an amplifier with a built-in D/A converter, you can connect the player's DIGITAL OUTPUT jack (2), to the digital input socket. Use a proper digital interconnect cable of 75 ohm impedance, available from your dealer.

### 3. CONNECTING THE POWER CORD

Connect the power cord (3) to the AC (mains) outlet. Always handle the power cord with care and never pull the plug out by tugging the cord. Instead hold the cord by the plug and gently pull.

**NOTE:** Verify that all connections are properly and securely made and that the player and amplifier have been plugged in. Hum and noise may be caused either by improper connection between turntable, tuner, amplifier and/or speakers, or as a result of different grounding or location of the components. Check that the audio interconnect cables are completely inserted into their jacks on both player and amplifier.

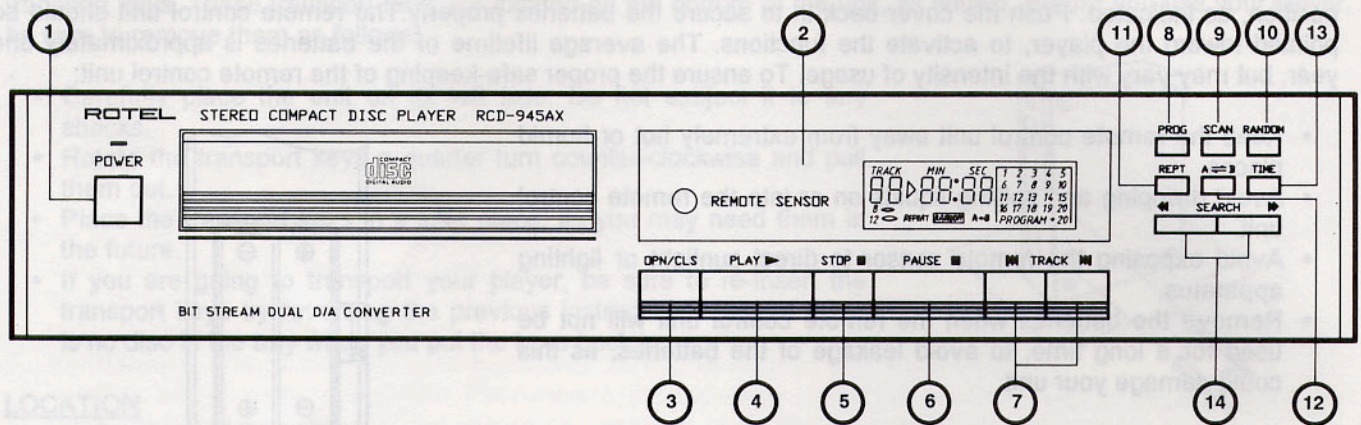

**1. POWER BUTTON/INDICATOR**

The POWER button switches the player on and off. After having made all the connections, press the POWER button to switch the player on (indicated by the red POWER indicator), or off.

**2. REMOTE SENSOR & MULTI-FUNCTION DISPLAY**

The remote sensor receives commands from the remote control unit. The display provides comprehensive information on the number of tracks on the disc, the playing time, the state of play and special functions of the player. The different displays and modes are described below:

- **Disc size indicator** - an oval figure on the bottom left-hand side of the display shows the number 12 or 8 beside it, to indicate whether a 12cm/5" or an 8cm/3" disc is inserted in the tray.
- **PLAY mode** - when a disc is playing, the display indicates the currently playing track number, the PLAY symbol (>), and the elapsed track playing time. On the right-hand side there is a track calendar, which shows the tracks that still remain to be played.
- **STOP mode** - when a disc is correctly inserted in the player, it indicates: the number of tracks and playing length of the disc, the size of the disc and the track calendar (all track numbers are shown).
- **PAUSE mode** - shows a flashing PLAY indicator. The disc spins but sound is muted.
- **PROG mode** - when programming, the letter P appears beside the chosen track number, and the word "PROGRAM" and track number appear in the track calendar on the right-hand side.
- **SCAN mode** - the disc size indicator (small oval figure) flashes when the player is in SCAN mode.
- **RANDOM mode** - the word 'RANDOM' appears in the track calendar and the tracks flash around the screen until the player randomly selects a track to be played.
- **REPEAT mode** - shows the word 'REPEAT', either still - to indicate 'disc or program' repeat -, or flashing - to indicate 'single track' repeat.
- **A<>B mode** - shows the word 'A<>B' flashing, to indicate the start point of the selected section has been set. The 'A<>B' word stops flashing when the end point of the section has been set.
- **TIME display** - shows either elapsed track, elapsed disc, or remaining disc playing times, depending on which mode the player is in, and on how many times the TIME button is pressed.

**3. OPEN/CLOSE BUTTON (OPN/CLS)**

Slides the disc tray in or out of the player, for loading or unloading the discs. When the disc tray closes and a disc is loaded, the player also automatically reads the disc's table of contents.

- To open, press the OPN/CLS button. The disc tray slides out and the display indicates OPEN.
- Remove a disc from its case, holding it by its edges and insert it flat in the tray with the printed side facing upwards. If it is a 12cm/5" disc place it within the outer grooves of the tray. If it is an 8cm/3" disc (CD single), place it within the inner grooves of the tray.
- Do not place more than one disc in the disc tray. If no disc is loaded or a disc is loaded incorrectly (e.g. upside down) in the disc tray, the display indicates there is no disc by showing the word 'DISC'.
- After correctly loading a disc, close the disc tray in one of three ways: press the OPN/CLS button; press the PLAY button; or push the disc tray gently inside the player. If the disc tray is closed by pushing it or by pressing the PLAY button, the disc automatically starts playing once the disc tray is fully closed.
- Press the OPN/CLS button to stop playback and have the disc tray slide out at the same time. The disc stops playing immediately, the word OPEN appears on the display and the disc tray slides out of the player.

#### 4. PLAY BUTTON

Initiates playback of the disc, selected track or program, and re-starts playback of the currently playing track. This function is also available from the remote control unit.

- To play the disc from beginning to end, press the PLAY button either after placing the disc on the disc tray, or after the tray and disc have slid inside the player. The player reads the contents list of the disc, shows it is in PLAY mode, and begins playback.
- Pressing the PLAY button while a track is playing, returns to play the beginning of the track (re-PLAY).
- To start playback with a different track, press the TRACK buttons to select the desired track and then press the PLAY button. The chosen track number appears on the display and play begins with the selected track and then plays the rest of the tracks on the disc.
- When all the tracks have been played, the player goes into STOP mode.

NOTE: Do not wait more than 4 or 5 seconds between pressing the TRACK button and the PLAY button, otherwise the player will return to STOP mode.

#### 5. STOP BUTTON

Stops disc playback. To end play before the disc has ended, press the STOP button. Playback stops and the display shows it is in STOP mode. This function is also available from the remote control unit.

#### 6. PAUSE BUTTON

Interrupts playback and holds play at the start of a track or passage. This function is also available from the remote control unit.

##### **Interrupting playback**

- For short playback interruptions press the PAUSE button when in PLAY mode. The play indicator on the display flashes to indicate the player is in PAUSE mode.
- The disc continues to spin at that point but the sound is muted. The re-PLAY, SEARCH and TRACK buttons can be used during PAUSE mode to move to a different track or passage of the disc. When playback is resumed, the new track or passage will be played.
- To cancel the PAUSE mode, press the PAUSE button again. Sound re-starts either at the exact point where playback was interrupted, or at the new point moved to while in PAUSE mode. PAUSE mode is also canceled if the STOP or OPN/CLS buttons are pressed.

##### **Holding play at the start of a track or passage**

- Press the PAUSE button while in STOP mode. No PAUSE indicator is displayed. Press the PLAY button, the disc starts spinning but the sound is muted. The player now shows it is in PAUSE mode.
- Use the TRACK, SEARCH and re-PLAY buttons, to reach a desired track or passage in the disc.
- Press the PAUSE button to begin play at the chosen point in the disc.

#### 7. << TRACK >> BUTTONS

Moves sequentially across the disc to the beginning of each track, in either a forward (>>) or reverse (<<) direction. This function is also available from the remote control unit.

- The TRACK buttons can move in single steps if pressed a single time, or continuously if the buttons are held down. To select the next track, press the TRACK >> button. To select the previous track press the << TRACK button.
- While in STOP mode, continuously press one of the TRACK buttons. The player moves continuously along the tracks in either direction until the TRACK button is released.
- While in PLAY mode, continuously press one of the TRACK buttons. The player moves in either direction, but when the discs limits are reached the word 'Err' (error) is shown. Playback of the track begins when the TRACK button is released.

#### 8. PROG BUTTON

Compiles personally selected tracks into a program. This function is also available from the remote control unit.

##### **Programming a selected number of tracks for playback**

- You can only compile a program when the disc is loaded and the player is in STOP mode.
- To compile a program: select the first track and then press the PROG button - the display shows it is in PROG mode. To include more tracks in the program, follow these instructions repeatedly.

- A track may only be stored once, though any track may be stored in any order. The track calendar shows each programmed track number.
- Do not allow more than 5 seconds to elapse between pressing the track number and pressing the PROG button, otherwise the player will go into STOP mode.
- If more than 20 entries are stored, the display will indicate 'FULL'.
- Pressing the PROG button without having selected or stored any tracks will show the word 'Err' (error) on the display.

### **Playing and reviewing a program**

- Press the PLAY button. Playback starts with the first entry or track number of the program. The track calendar shows the programmed tracks that still remain to be played.
- When all the tracks on the program have been played, the player goes into STOP mode.
- All playback functions remain the same as with an unprogrammed disc, except: SCAN - only scans the programmed tracks; TIME - only shows the elapsed track time on the display; and SEARCH - only searches through the currently playing track.
- Press the PROG button to review the order of the whole program. The display will show an 'r' (review), as the player runs briefly through the chosen sequence of programmed tracks.

### **Deleting a track or the whole program**

- To delete a track, select the track number you want deleted while in STOP mode, and press the PROG button. The P and the track number from the track calendar, will disappear from the display.
- To delete the whole program, press the STOP button while the player is in STOP mode. The program can also be deleted by pressing either the OPN/CLS, the RANDOM or the A<>B button.

## **9. SCAN BUTTON**

Plays an introductory first 10 seconds of all the tracks on the disc or program. This function is also available from the remote control unit.

- Press the SCAN button during PLAY mode. The disc size indicator (small oval figure in the display), flashes when the SCAN button is pressed to indicate the player is in SCAN mode.
- The SCAN and PLAY modes are cancelled when the player has scanned the whole disc or program.
- The re-PLAY function starts playback of the currently scanned track again.
- To cancel the SCAN mode, either press the SCAN button again, or press the OPN/CLS, STOP, RANDOM or A<>B button.
- The SEARCH buttons do not work when in SCAN mode.

## **10. RANDOM BUTTON**

Plays the tracks on the disc in a non-sequential (random) order, different to that predefined by the disc. This function is also available from the remote control unit.

- Press the RANDOM button. Faintly flashing tracks are shown in the track calendar, until the player generates a random track. Random tracks are then played until the RANDOM mode is cancelled.
- The player selects all the tracks of the disc without repeating them. To skip to the next track, press one of the TRACK buttons.
- The SEARCH buttons only search through the currently playing track.
- To cancel the RANDOM mode, either press the RANDOM button again, or the OPN/CLS, STOP, SCAN or A<>B buttons. Normal playback continues from that point onwards.

## **11. REPEAT BUTTON (REPT)**

Initiates repeat playback either of the entire disc, program or currently playing track. This function is also available from the remote control unit.

### **Whole disc or whole program repeat**

- Press the REPEAT button once. The REPEAT indicator appears in the display. If you are in STOP mode, press the PLAY button to initiate playback.
- After the player reaches the last track on the disc or program, it automatically starts playing the first track again. The disc or program continues to be repeated until the REPEAT mode is cancelled.

## Track repeat

- If in STOP mode, chose the track you want repeated. Press the REPEAT button twice. The REPEAT indicator on the display starts flashing. Press the PLAY button to initiate repeat playback.
- If in PLAY mode, press the REPEAT button twice (the REPEAT indicator flashes). The currently playing track will be continuously repeated.
- The track is repeated until the REPEAT mode is cancelled.

## Cancelling the repeat mode

- To cancel the repeat "whole disc or program" mode, press the REPEAT button twice.
- To cancel the repeat "track" mode, press the REPEAT button once.
- The repeat mode can also be canceled by pressing either the OPN/CLS or STOP button.

## 12. A<>B BUTTON

Programs a section of the track or disc, so it will loop or repeat itself continuously (useful for example, for learning the chords or words of a song, or for producing special effects when recording). This function is also available from the remote control unit.

- While in PLAY mode, press the A<>B button at the desired starting point of the section you want repeated. The A<>B indicator starts flashing, indicating that the starting point of the section is set.
- Press the A<>B button again at the desired ending point. The A<>B indicator is now lit continuously, indicating the end point of the section is set. The player immediately starts playing the programmed section continuously.
- To cancel the A<>B mode, press the A<>B button again. The A<>B indicator disappears and normal playback continues from that point onwards. The OPN/CLS, STOP, SCAN or RANDOM buttons also cancel the A<>B mode.
- Pressing the PLAY button after setting the A<>B mode, returns the player to the beginning of the currently playing track. If the beginning of the track is not within the programmed A<>B section, the disc carries on playing normally until it reaches the A<>B section. From then on the A<>B section will be repeated continuously.

## 13. TIME BUTTON

Switches between readouts of the elapsed track, elapsed disc and remaining disc times. This function is also available from the remote control unit.

- The default TIME display during STOP mode shows the total number of tracks and the total playing time of the loaded disc.
- The default TIME display during PLAY mode, shows the elapsed track playback time. Press the TIME button once, to show the elapsed disc playback time; press the TIME button again, to show the remaining disc playback time; and press the TIME button once more, to revert to the default elapsed track playback time.
- During PROGRAM or RANDOM modes, only the default elapsed track playback time is shown.

## 14. << SEARCH >> BUTTONS

Scans the disc in a forward (>>) or reverse (<<) direction, to locate a particular passage in a track. This function is also available from the remote control unit.

- During PLAY mode, hold down either the << SEARCH button to scan backwards, or the SEARCH >> button to scan forwards. When the buttons are released playback starts immediately.
- During SEARCH mode, the player moves at two successive speeds. During the first speed, the sound of the disc remains audible, making it easier to find the exact passage. The top speed is reached after two seconds, at which point the sound is muted.
- The unit stops searching once it reaches either limit on the disc, though the disc will continue spinning. Play is resumed when the SEARCH buttons are released.
- When the unit is in SCAN mode, the search function does not work. When the player is in PROGRAM or RANDOM modes, the search function stops at the limits of the current track.

## LOCATION AND OPERATION OF CONTROLS - Remote Control Unit

NOTE: The remote control unit duplicates exactly all front panel functions except the POWER and OPN/CLS buttons. To see the operating instructions of the remote control unit buttons, please refer to buttons 4 to 14 in the previous section. Added also to the remote control unit, are the Direct Track Access buttons, explained below:

### DIRECT TRACK ACCESS BUTTONS

Allow easier and direct selection of a desired track, without having to use the TRACK buttons.

- To access a track press the desired track number from the ten-key pad. If the number is a two-digit number, press the two corresponding buttons quickly, one after the other. The player waits 1.5 seconds before playing the track, so you have time to press two buttons if necessary. The selected track is shown on the display.
- If one of the Direct Track Access buttons is pressed during PROG mode, and the chosen track number was not previously stored in the program, the display indicates 'Err' (error).

NOTE: When the remote control unit is used, the player acknowledges reception of the commands by flashing the words TRACK, MIN and SEC and the track calendar box, in the display. They will flash as long as any of the remote control unit buttons is being pressed.

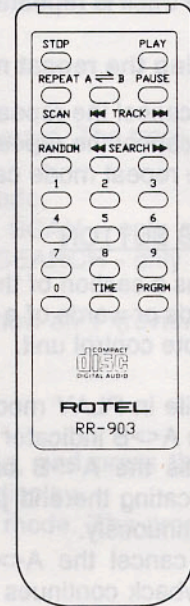

## TROUBLESHOOTING GUIDE

If your CD player does not seem to function properly or you suspect it is faulty, please consult the points below to check if the problem can be solved without first calling up a technician. Under no circumstances should you open the player, as you may cause damage and void the warranty.

### The display and POWER Indicator do not light up

- The AC (mains) plug is not connected properly into the AC (mains) outlet.
- The player is not connected properly or the POWER button has not been pressed in far enough.
- There is no power supply at the AC (mains) outlet. Check if another appliance works in that outlet.

### The disc tray does not slide in or out

- The transport keys have not been removed.
- The player is not switched on or the AC (mains) supply has been interrupted. Check that the display is lit.
- There is an unwanted object in the disc tray.
- The player has not received the command properly. Try switching the POWER button off and on again.

### 'Disc' and 'err' (error) light up on the display

- The disc is not inserted with the label upwards, there is no disc in the tray, or the disc has not been inserted correctly in the tray.
- The disc is dirty. Try cleaning the disc or inserting another clean disc.
- The disc is defective. Try another disc.
- There is an unwanted object in the disc tray.

### There is no sound while the disc is being played

(To ensure the disc is playing, check that the time indicator is moving on regularly.)

- The amplifier is not switched on.
- The amplifier source selector is set to the wrong input.
- The amplifier or the loudspeakers connected to it are not working. Check with another sound source.
- The player has not received the command properly. Try switching the POWER button off and on again.
- The headphone jack is not plugged in, or the volume control is set to the minimum.
- The connection between the player and the amplifier is broken.
- The input to which the player is connected is defective. Try connecting the player into another input.

### The sound is poor or distorted or you can hear only one channel

- The player is connected to the amplifier's PHONO input, instead of the CD or AUX inputs.
- The interconnect cables or the headphone jack are not connected properly, or are defective.
- The disc is dirty or badly scratched. Try cleaning or using another disc.
- The amplifier or loudspeakers are not working properly. Check another sound source.

### Programming is not working

- The player has not processed the commands properly. Try switching the POWER off and on again.
- All 20 memory blocks are occupied and you have missed the word FULL that indicates this.

### The player does not react to commands from the remote control unit

- The distance between the player and the remote control unit is too great.
- You did not aim accurately enough in the direction of the player.
- The batteries are weak or dead.

### Playback does not work

- The laser pick-up has been covered with moisture condensation, due to rapid changes in temperature or exposure to high levels of dampness. Remove the disc, and leave the player switched on for about an hour until the moisture evaporates.

## SPECIFICATIONS

---

### DIGITAL

Laser type.....	Semiconductor 1 beam
Nominal Speed Range.....	200 - 600 rpm
Digital Filter.....	4 Fs two-stage FIR type
Total Oversampling.....	192 times
Noise Shaper.....	2nd order
D/A Converter.....	One-bit differential bitstream

### AUDIO

Number of Channels.....	2
Frequency Range.....	20 to 20,000 Hz
Output Level.....	2.0 Vrms
Minimum Load Impedance.....	10 kohms
Amplitude Linearity.....	+/- 0.05 dB
Channel Balance.....	+/- 0.5 dB
Phase Linearity.....	+/- 0.5 degrees
Signal-to-Noise Ratio.....	100 dB
Dynamic Range.....	96 dB
Channel Separation.....	100 dB (1kHz)
THD + Noise.....	0.0025% (1kHz)
Intermodulation Distortion.....	0.0025% (1kHz)
Out-Band Rejection.....	>60 dB, above 24.1 kHz
Wow and Flutter.....	Quartz Crystal Precision

### DIGITAL OUTPUT

Output Level.....	0.5 Vpp
Load Impedance.....	75 Ohms

### GENERAL

AC (mains) Voltage.....	100 - 120 V / 60 Hz (depending on local requirements) 220 - 240 V / 50 Hz (depending on local requirements)
Power Consumption.....	30 watts
Main Cabinet Material and Finishing.....	Metal sheet, anti-corrosion plated and painted
Front Panel Material and Finishing.....	Anodized aluminum, hairline brushed
Overall Dimensions.....	440(W) x 92 (H) x 316 (D) mm 17-3/8" (W) x 3-5/8" (H) x 12-7/16"
Net Weight.....	5.8 kg / 12.76 lbs

NOTE: Specifications and design are subject to possible modification without notice.