

# RYOBI®

## RCS36/RCS36B

### 36V CORDLESS CHAIN SAW

OPERATOR'S MANUAL (Original Instructions)

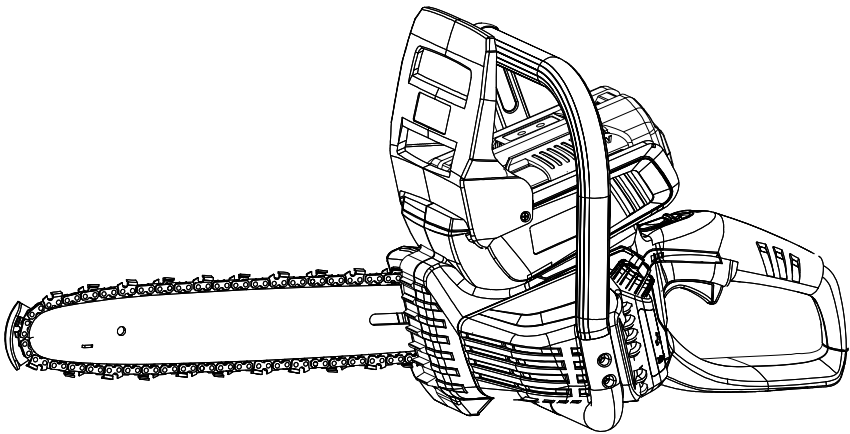

  
N197

***Important!***

It is essential you read the instructions in this manual before starting and operating this machine.

# RYOBI® RCS36 / RCS36B

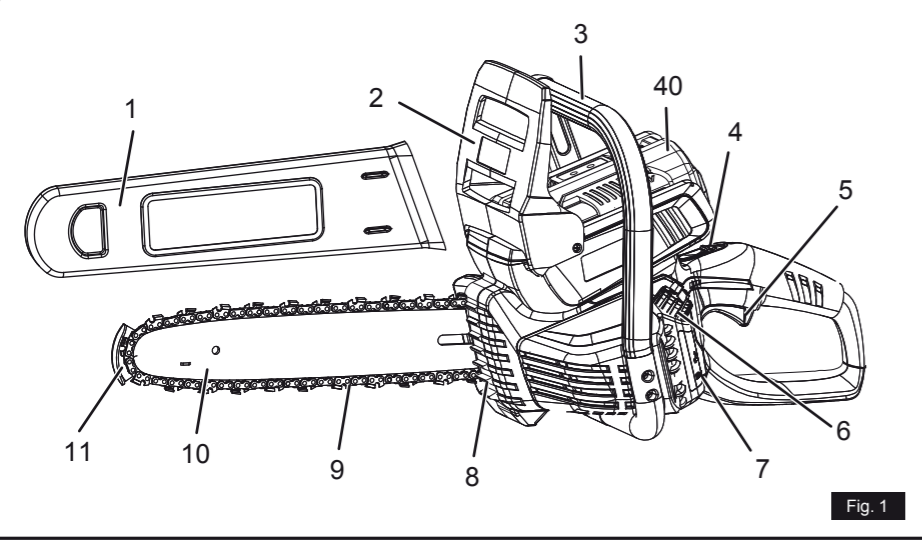

Fig. 1

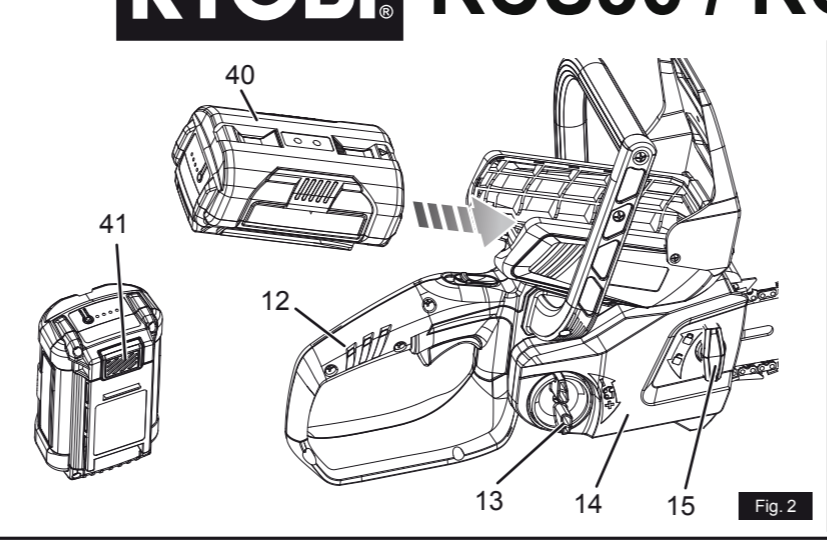

Fig. 2

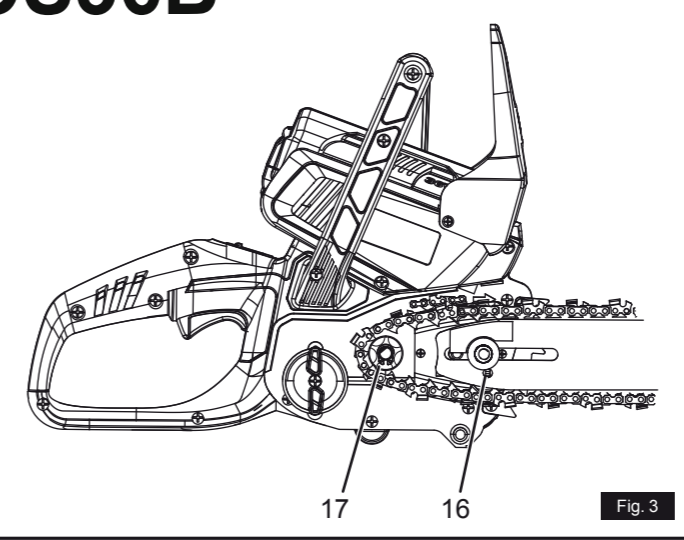

Fig. 3

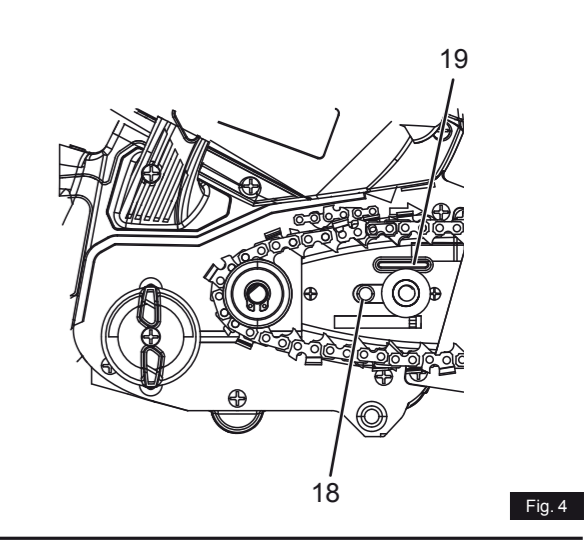

Fig. 4

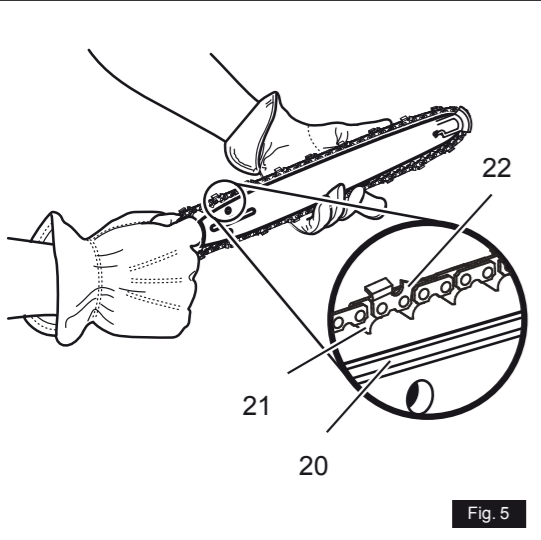

Fig. 5

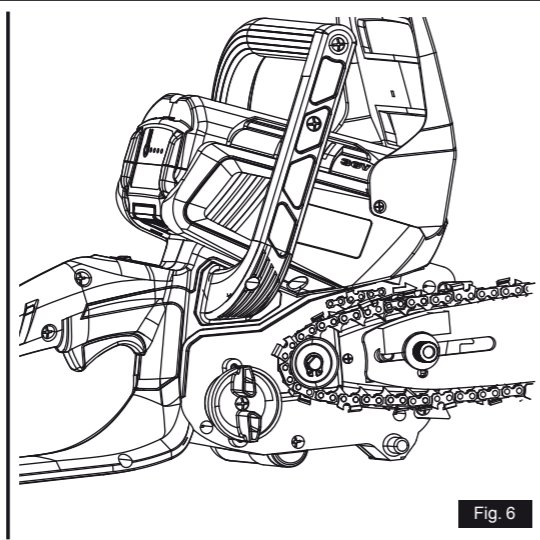

Fig. 6

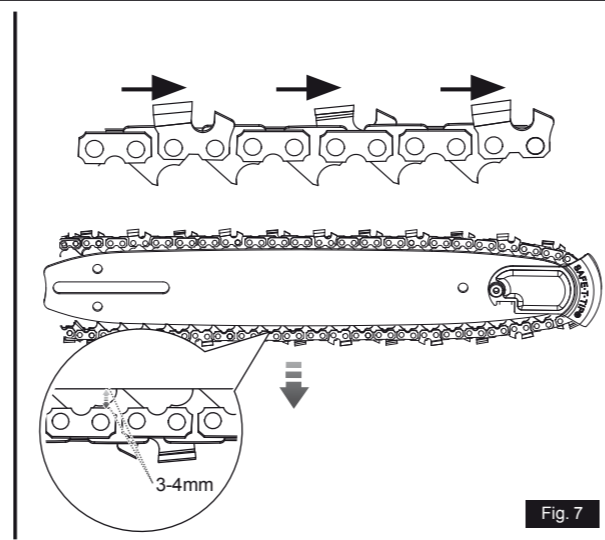

Fig. 7

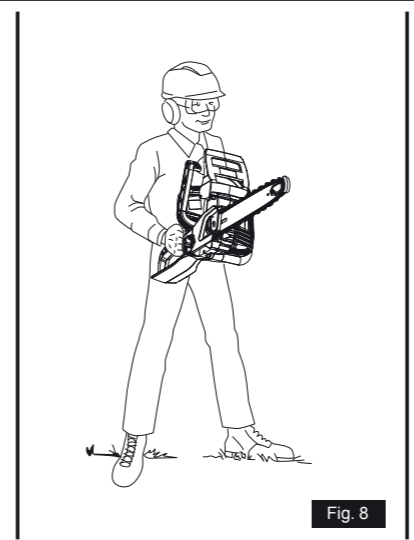

Fig. 8

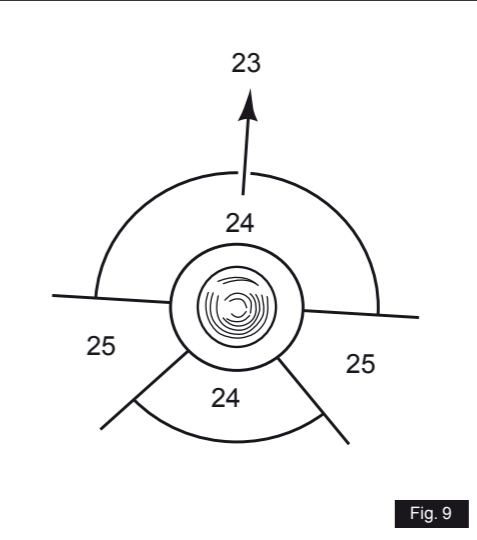

Fig. 9

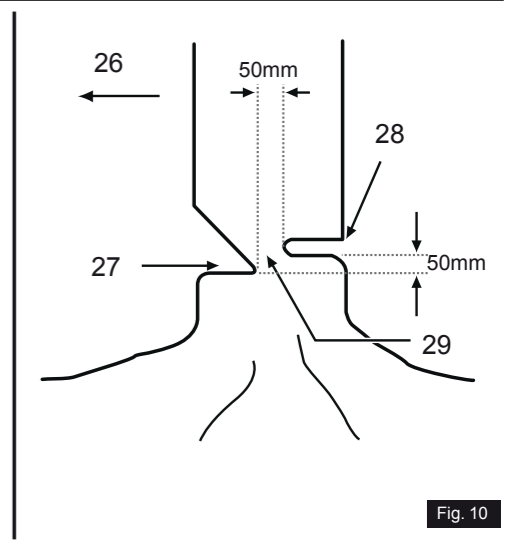

Fig. 10

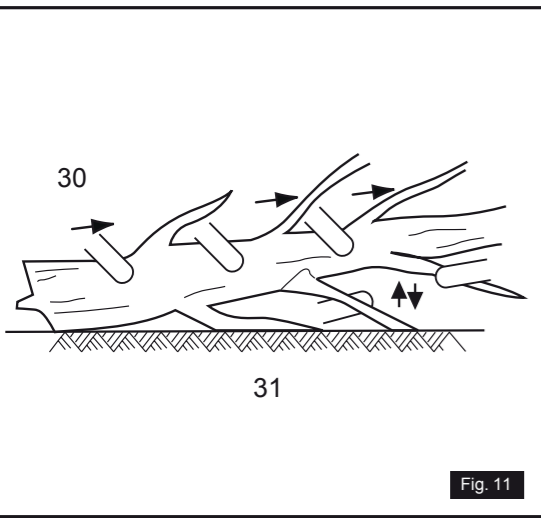

Fig. 11

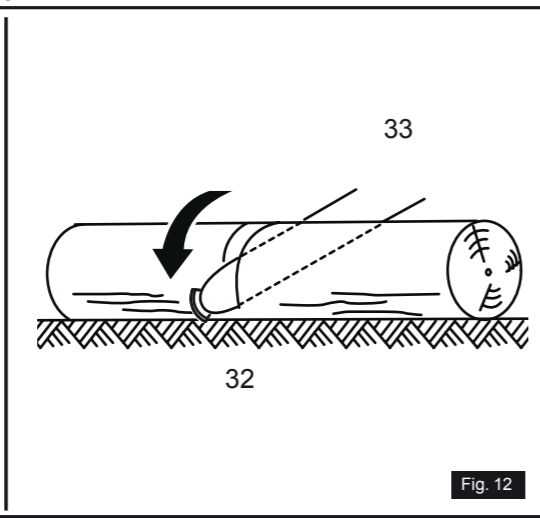

Fig. 12

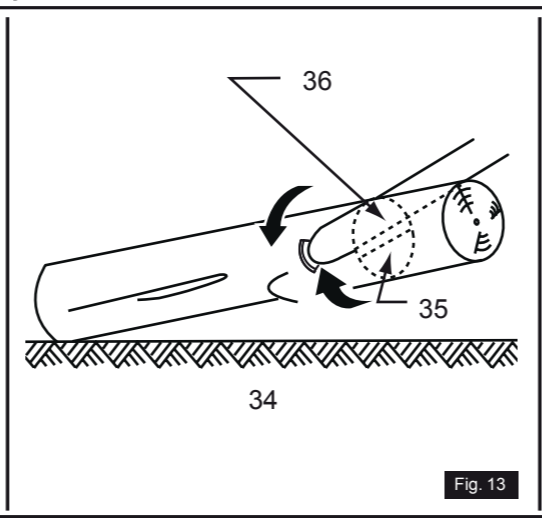

Fig. 13

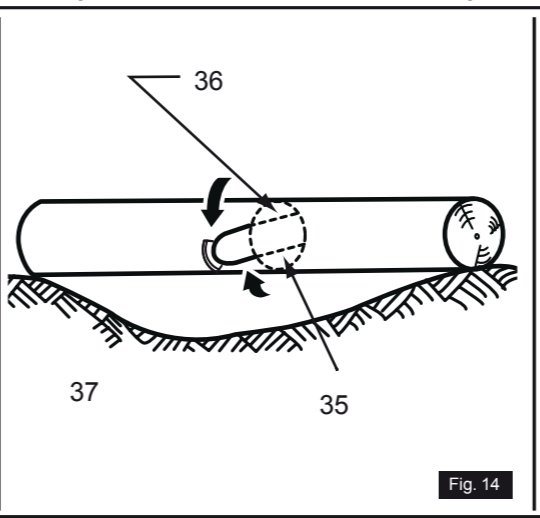

Fig. 14

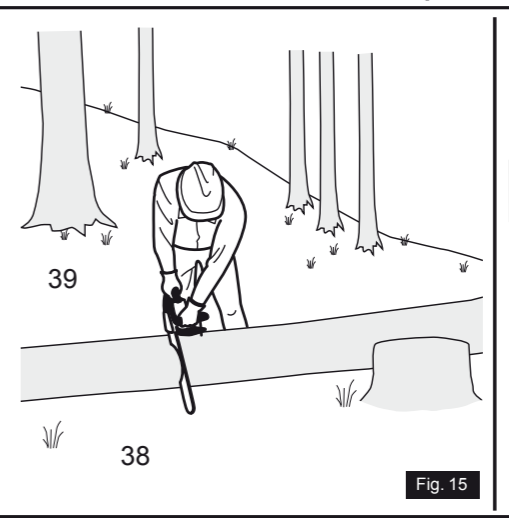

Fig. 15

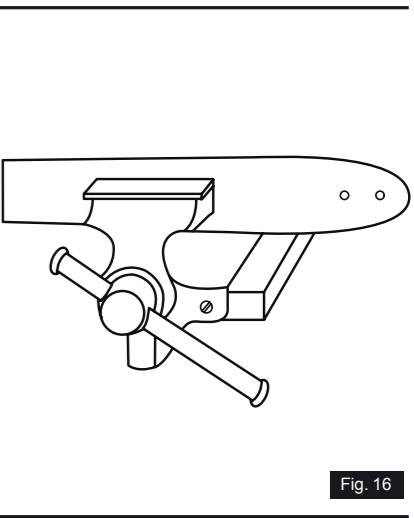

Fig. 16

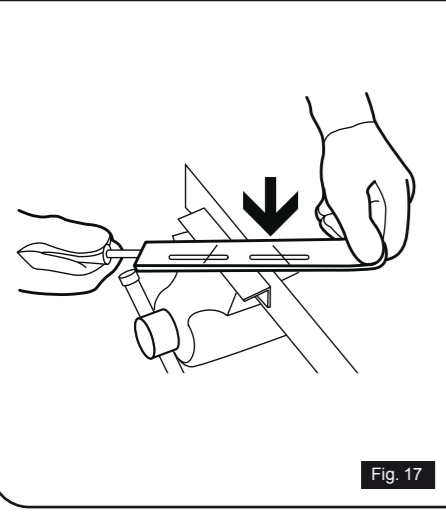

Fig. 17

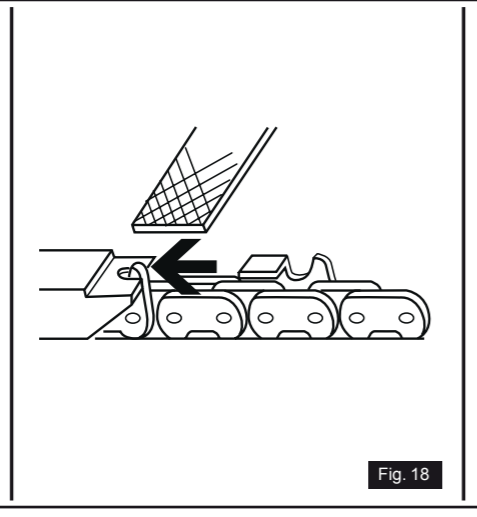

Fig. 18

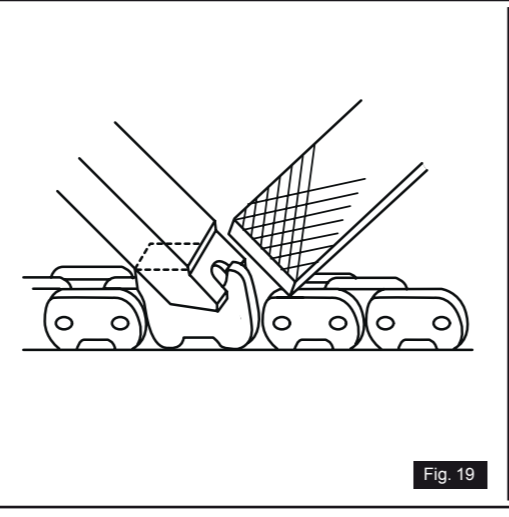

Fig. 19

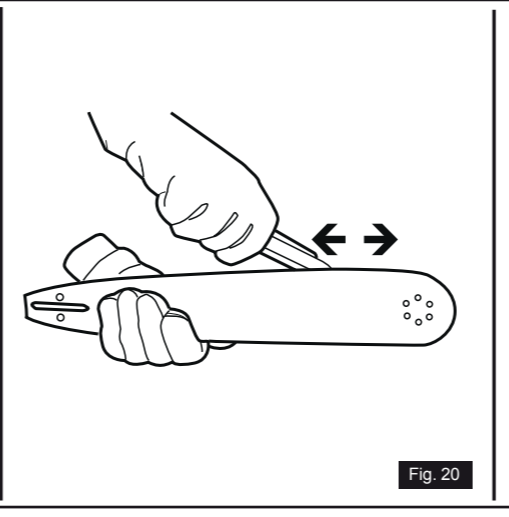

Fig. 20

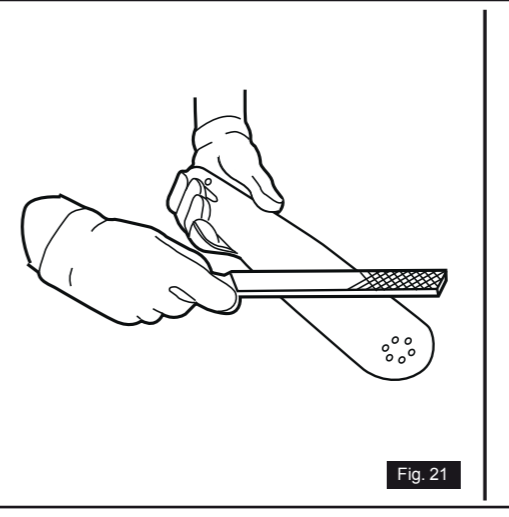

Fig. 21

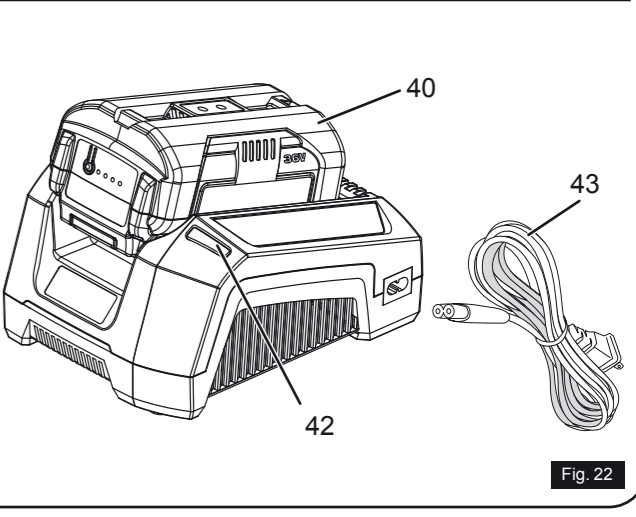

Fig. 22

## English (Original Instructions)

Your product has been engineered and manufactured to Ryobi's high standard for dependability, ease of operation, and operator safety. When properly cared for, it will give you years of rugged, trouble-free performance.

Thank you for buying a Ryobi product.

### GENERAL SAFETY WARNINGS

#### WARNING

Read all safety warnings and all instructions. Failure to follow the warnings and instructions may result in electric shock, fire and/or serious injury.

#### INTENDED USE

This chainsaw is designed for cutting branches, trunks, logs and beams of a diameter determined by the cutting length of the guide bar. It is only designed to cut wood. It is only to be used in an outdoor, domestic application by adults.

Do not use the chainsaw for any purpose not listed above.

This chainsaw is not to be used for professional tree services. It is not to be used by children or by persons not wearing adequate personal protective equipment and clothing.

#### RESIDUAL RISKS:

Even with the intended use of the appliance, there are other potential risks which cannot be prevented. According to the type and construction of the appliance, the following potential hazards exist:

- Contact with exposed saw teeth of the saw chain (cutting hazards).
- Access to the rotating saw chain (cutting hazards).
- Unforeseen, abrupt movement of the guide bar (cutting hazards).
- [Flying parts from the saw chain](#) (Cutting / injection hazards).
- [Flying debris from the work piece.](#)
- Inhalation of work piece particles.
- Skin contact with the fuel oil.
- Loss of hearing, if no ear protection is used during work.
- **Save all warnings and instructions for future reference.** The term "power tool" in the warnings refers to your mains-operated (corded) power tool or battery-operated (cordless) power tool.

#### WORK AREA SAFETY

- **Keep work area clean and well lit.** Cluttered or dark areas invite accidents.

- **Do not operate power tools in explosive atmospheres, such as in the presence of flammable liquids, gases or dust.** Power tools create sparks which may ignite the dust or fumes.
- **Keep children and bystanders away while operating a power tool.** Distractions can cause you to lose control.

#### ELECTRICAL SAFETY

- **Avoid body contact with earthed or grounded surfaces, such as pipes, radiators, ranges and refrigerators.** There is an increased risk of electric shock if your body is earthed or grounded.
- **Do not expose power tools to rain or wet conditions.** Water entering a power tool will increase the risk of electric shock.

#### PERSONAL SAFETY

- **Stay alert, watch what you are doing and use common sense when operating a power tool.** Do not use a power tool while you are tired or under the influence of drugs, alcohol or medication. A lapse of attention while operating power tools may result in serious personal injury.
- **Use personal protective equipment.** Always wear eye protection. Protective equipment such as a dust mask, non-skid safety shoes, hard hat or hearing protection used appropriately will reduce personal injuries.
- **Prevent unintentional starting.** Ensure the switch is in the off position before connecting to power source and/or battery pack and when picking up or carrying the tool. Carrying power tools with your finger on the switch or energizing power tools that have the switch on invites accidents.
- **Remove any adjusting key or wrench before turning the power tool on.** A wrench or a key left attached to a rotating part of the power tool may result in personal injury.
- **Do not over-reach.** Keep proper footing and balance at all times. This enables better control of the power tool in unexpected situations.
- **Dress properly. Do not wear loose clothing or jewellery. Keep your hair, clothing and gloves away from moving parts.** Loose clothes, jewellery or long hair can be caught in moving parts.
- **If devices are provided for the connection of dust extraction and collection facilities, ensure these are connected and properly used.** Use of dust collection can reduce dust-related hazards.

#### POWER TOOL USE AND CARE

- **Do not force the power tool.** Use the power tool for the application. The correct power tool will do the job better and safer at the rate for which it was designed.

## English (Original Instructions)

- **Do not use the power tool if the switch does not turn it on and off.** Any power tool that cannot be controlled with the switch is dangerous and must be repaired.
- **Disconnect the battery pack from the power tool before making any adjustments, changing accessories, or storing power tools.** Such preventive safety measures reduce the risk of starting the power tool accidentally.
- **Store idle power tools out of the reach of children and do not allow persons unfamiliar with the power tool or these instructions to operate the power tool.** Power tools are dangerous in the hands of untrained users.
- **Maintain power tools.** Check for misalignment or binding of moving parts, breakage of parts and any other condition that may affect the power tool's operation. If damaged, have the power tool repaired before use. Many accidents are caused by poorly maintained power tools.
- **Keep cutting tools sharp and clean.** Properly maintained cutting tools with sharp cutting edges are less likely to bind and are easier to control.
- **Use the power tool, accessories and tool bits etc. in accordance with these instructions, taking into account the working conditions and the work to be performed.** Use of the power tool for operations different from those intended could result in a hazardous situation.

### BATTERY TOOL USE AND CARE

- **Ensure the switch is in the off position before inserting battery pack.** Inserting the battery pack into power tools that have the switch on invites accidents.
- **Recharge only with the charger specified by the manufacturer.** A charger that is suitable for one type of battery pack may create a risk of fire when used with another battery pack.
- **Use power tools only with specifically designated battery packs.** Use of any other battery packs may create a risk of injury and fire.
- **When battery pack is not in use, keep it away from other metal objects like paper clips, coins, keys, nails, screws, or other small metal objects that can make a connection from one terminal to another.** Shorting the battery terminals together may cause burns or fire.
- **Under abusive conditions, liquid may be ejected from the battery; avoid contact.** If contact accidentally occurs, flush with plenty of soap and water. If liquid contacts eyes, immediately seek medical help. Liquid ejected from the battery may cause irritation or burns.

### SERVICE

- **Have your power tool serviced by a qualified repair person using only identical replacement parts.** This will ensure that the safety of the power tool is maintained.

Servicing requires extreme care and knowledge and should be performed only by a qualified service technician. For service we suggest you return the product to your nearest AUTHORISED SERVICE CENTRE for repair. When servicing, use only identical replacement parts.

### SPECIFIC SAFETY WARNINGS

- Hold the power tool by insulated gripping surfaces only, because the saw chain may contact hidden wiring. Saw chains contacting a "live" wire may make exposed metal parts of the power tool "live" and could give the operator an electric shock.
- Keep all parts of the body away from the saw chain when the chain saw is operating. Before you start the chain saw, make sure the saw chain is not in contact with anything. A moment of inattention while operating chain saws may cause entanglement of your clothing or body with the saw chain.
- Always hold the chain saw with your right hand at the rear handle and your left hand at the front handle. Holding the chain saw with a reversed hand configuration increases the risk of personal injury and should never be done.
- Wear safety glasses and hearing protection. Further protective equipment for head, hands, legs and feet is recommended. Adequate protective clothing will reduce personal injury from flying debris or accidental contact with the saw chain.
- Do not operate chain saw while up in a tree. Operation of a chain saw while up in a tree may result in personal injury.
- Always keep proper footing and operate the chain saw only when standing on fixed, secure and level surface. Slippery or unstable surfaces such as ladders may cause loss of balance or control of the chain saw.
- When cutting a limb that is under tension, be alert of spring back. When the tension in the wood fibres is released, the spring loaded limb may strike the operator and/or throw the chain saw out of control.
- Use extreme caution when cutting brush and saplings. The slender material may catch the saw chain and be whipped toward you or pull you off balance.
- Carry the chain saw by the front handle with the chain saw switched off and away from your body. When transporting or storing the chain saw, always fit the guide bar cover. Proper handling of the chain saw will reduce the likelihood of accidental contact with the

## English (Original Instructions)

moving saw chain.

- Follow instructions for lubricating, chain tensioning and changing accessories. Improperly tensioned or lubricated chain may either break or increase the chance for kickback.
- Keep handles dry, clean, and free from oil and grease. Greasy, oily handles are slippery, **and may cause loss of control**.
- Cut wood only. Do not use chain saw for purposes not intended. For example: do not use chain saw for cutting plastic, masonry or non-wood building materials. Use of the chain saw for operations other than intended could result in a hazardous situation.

### CAUSES AND OPERATOR PREVENTION OF KICKBACK:

Kickback may occur when the nose or tip of the guide bar touches an object, or when the wood closes in and pinches the saw chain in the cut.

Tip contact in some cases may cause a sudden reverse reaction, kicking the guide bar up and back towards the operator.

Pinching the saw chain along the top of the guide bar may push the guide bar rapidly back towards the operator.

Either of these reactions may cause you to lose control of the saw which could result in serious personal injury. Do not rely exclusively upon the safety devices built into your saw. As a chain saw user, you should take several steps to keep your cutting jobs free from accident or injury.

Kickback is the result of tool misuse and/or incorrect operating procedures or conditions and can be avoided by taking proper precautions as given below:

- Maintain a firm grip, with thumbs and fingers encircling the chain saw handles, with both hands on the saw and your body and arm positioned to allow you to resist kickback forces.
- Kickback forces can be controlled by the operator, if proper precautions are taken. Do not let go of the chain saw.
- Do not overreach and do not cut above shoulder height. This helps prevent unintended tip contact and enables better control of the chain saw in unexpected situations.
- Only use replacement bars and chains specified by the manufacturer. Incorrect replacement bars and chains may cause chain breakage and/or kickback.
- Follow the manufacturer's sharpening and maintenance instructions for the saw chain. Decreasing the depth gauge height can lead to increased kickback.

### ADDITIONAL WARNINGS

- It has been reported that vibrations from hand-held tools may contribute to a condition called Raynaud's Syndrome in certain individuals. Symptoms may include tingling, numbness and blanching of the fingers, usually apparent upon exposure to cold. Hereditary factors, exposure to cold and dampness, diet, smoking and work practices are all thought to contribute to the development of these symptoms. It is presently unknown what, if any, vibrations or extent of exposure may contribute to the condition. There are measures that can be taken by the operator to possibly reduce the effects of vibration:

- Keep your body warm in cold weather. When operating the unit wear gloves to keep the hands and wrists warm. It is reported that cold weather is a major factor contributing to Raynaud's Syndrome.
- After each period of operation, exercise to increase blood circulation.
- Take frequent work breaks. Limit the amount of exposure per day.

If you experience any of the symptoms of this condition, immediately discontinue use and see your physician about these symptoms.







- The recommended cutting capacity of this chain saw is 153mm (6 in.) and smaller to prolong the life of the tool and allow for safest operation. Cutting logs with a diameter larger than this will cause excess wear on your tool. Logs with a maximum diameter of 229mm (9in.) can be cut, but should only be done so rarely and with caution.
- The integral spiked bumper is designed to assist cutting. When forced against the log while cutting it provides a more stable pivot point.
- Any chainsaw is potentially lethal if used inappropriately. It is strongly suggested that you seek professional training in the safety and use of this tool.

**SAVE THESE INSTRUCTIONS. REFER TO THEM FREQUENTLY AND USE THEM TO INSTRUCT OTHERS WHO MAY USE THIS UNIT. IF YOU LOAN SOMEONE THIS UNIT, LOAN THEM THESE INSTRUCTIONS ALSO.**



## English (Original Instructions)

### SYMBOLS

Some of the following symbols may be used on this tool. Please study them and learn their meaning. Proper interpretation of these symbols will allow you to operate the tool better and safer.

SYMBOL	DESIGNATION/EXPLANATION
V	Voltage
W	Watt - Power
	Direct current - Type or characteristic of current
	Precautions that involve your safety.
	Read the operation manual and follow all warnings and safety instructions.
	Wear eye and hearing protection when operating this product.
	Do not expose to rain or damp conditions.
	Guaranteed sound power level is 97dB.

The following signal words and meanings are intended to explain the levels of risk associated with this product.

SYMBOL	SIGNAL	MEANING
	<b>DANGER:</b>	Indicates an imminently hazardous situation, which, if not avoided, will result in death or serious injury.
	<b>WARNING:</b>	Indicates a potentially hazardous situation, which, if not avoided, could result in death or serious injury.
	<b>CAUTION:</b>	Indicates a potentially hazardous situation, which, if not avoided, may result in minor or moderate injury.
	<b>CAUTION:</b>	(Without Safety Alert Symbol) Indicates a situation that may result in property damage.

## English (Original Instructions)

### SPECIFICATIONS

Model	RCS36	RCS36B
Rated voltage	36V DC	
No Load Speed	3.6 m/s	
Guide bar length	300 mm	
Chain stop	< 2s	
Chain oil tank capacity	110 ml	
Weight	4.4 kg (with battery)	3.03 kg (without battery)
Emission sound pressure level $L_{pA}$	81.2 dB(A)	
Uncertainty $K_{pA}$	2 dB(A)	
Sound power level $L_{WA}$	94.8 dB(A)	
Uncertainty $K_{WA}$	2 dB(A)	
Guaranteed sound power level $L_{WA(G)}$	97 dB(A)	
Vibration total value $a_h$	2.3 m/s <sup>2</sup>	
Uncertainty $K$	1.5 m/s <sup>2</sup>	
Battery Pack	1 x BPL3626	
Battery Charger	1 x BCL3620	

#### REMARKS:

- The declared vibration value has been measured with a standard test method and may be used to compare one tool with another.
- The declared vibration value may be used in a preliminary assessment of exposure.

### ⚠ WARNING

The actual vibration values during use of the tool can be different from the above stated and depend on the use of the tool; and the need to identify safety measures to protect the operator are based on an estimation of exposure in the actual conditions of use (taking account all parts of the operating cycle such as the times when the tool is switched off and when it is running idle in addition to the trigger time).

### CHAIN & BAR INFORMATION

Manufacture	Saw chain	Guide bar
Oregon	90SG045X	124MLEA041
Tri-link	CL14345PB	M1431245-1041HL

Oregon's chain must be fitted with Oregon's bar; Tri-link's chain must be fitted with Tri-link's bar.

You can purchase bar and chain replacements from your Ryobi local dealer.

RCS36 bar replacement: RAC226 (Tri-link M1431245-1041HL)

RCS36 chain replacement: RAC227(Tri-link CL14345PB)

### DESCRIPTION

#### (REFER TO FIGURE SHEET)

1. Guide bar cover
2. Front handle guard
3. Front handle
4. Safety **lock-out** button
5. Switch trigger
6. Oil tank cover
7. Oil level gauge
8. Spike bumpers
9. Saw chain
10. Guide bar
11. Safety tip
12. Rear handle
13. Chain tensioner adjustment knob
14. Sprocket cover
15. Sprocket cover **securing** knob
16. **Saw chain tensioning pin**
17. Sprocket
18. Bar guide
19. Oil outlet
20. Bar groove
21. Chain drive links
22. Cutter
23. Felling direction
24. Danger zone
25. Escape route
26. Direction of fall
27. Notch
28. Felling back cut
29. Hinge
30. Limb cut
31. Keep work off ground leave support limbs until log is cut
32. Log supported along the entire length
33. Cut from top (over buck) avoid cutting earth
34. Log supported one end
35. Under buck

## English (Original Instructions)

36. Over buck
37. Log supported both ends
38. Bucking a log
39. Stand on uphill side when cutting because log may roll
40. Battery pack
41. Battery latch button
42. Charger
43. Charger cable

### ASSEMBLY

This chain saw does not require assembly, but user should know how to assemble the guide bar and saw chain. Check the chain tensioning and add oil as described later in this manual before each operation.

#### ASSEMBLING THE GUIDE BAR AND SAW CHAIN

See figure 2 - 7

Make sure remove the battery pack from the unit. Wear protective gloves.

- Unscrew the sprocket cover **securing** knob (item 15) and remove the sprocket cover.
- The saw chain should face in the direction of chain rotation. **If facing backwards, turn the chain loop over.**
- Place the chain drive links into the bar groove.
- Position the chain so there is a loop at the back of the bar.
- Hold the chain in position on the bar and place the loop around the sprocket and make sure it is correctly mounted. Make sure the bar hole fits well **with the tensioning pin** (item 16).
- Replace the sprocket cover, turn the chain tension adjust knob (item 13) clockwise until the saw chain is properly tensioned. The guide bar must then be pushed upwards, check chain tension again, do not tension the chain too tight.
- After the chain is well-tensioned, tighten the knob (item 15) again.

**Note:** The saw chain is properly tensioned if, in the middle of the guide bar, it can be lifted 3mm to 4mm from the edge of the guide bar. **Run the chain saw to ensure correct movement before attempting a job. If a new saw chain is fitted, run the saw for 2-3 minutes before starting a job.**

### ⚠ WARNING

After the run-in time, check the chain tension and retighten the chain if necessary.

### OPERATION

For complete charging instructions, refer to the Operator's Manuals for your Ryobi battery pack and

#### charger models.

**NOTE:** To avoid serious personal injury, always remove the battery pack and keep hands clear of the lock-out button when carrying or transporting the tool.

#### BEFORE EACH USE CHECK THE CHAIN TENSION

See figure 2

### ⚠ WARNING

Remove the battery pack from the chain saw before checking the chain tension or making adjustments to the chain. Wear protective gloves while touching the chain, bar or areas around the chain.

- Pull the chain in the middle of the lower side of the bar away from the bar. The gap between the cutter in the chain and the bar should be between 3mm - 4mm.
- If you need to adjust the chain tension, please refer to the section "ADJUSTING THE CHAIN TENSION" later in this manual.

#### TO INSTALL BATTERY PACK

See Figure 2.

- Place the battery pack in the chain saw. Align raised ribs on battery pack with grooves in the chain saw's battery port.
- Make sure the latch on bottom of the battery pack snaps in place and that battery pack is fully seated and secure in the chain saw before beginning operation.

#### TO REMOVE BATTERY PACK

See Figure 2.

- Release the trigger to stop the chain saw.
- Press and hold the battery latch button at the bottom of the battery pack.
- Remove battery pack from the chain saw.

#### CHECKING THE CHAIN LUBRICANT

See figure 1

- Check the amount of oil in the chain saw by looking at the oil level gauge (item 7). If the oil level is low, follow the steps shown in section "ADDING CHAIN & BAR LUBRICANT" of this manual.

### ⚠ WARNING

Check the chain tension before each use of the saw.

## English (Original Instructions)

### WARNING

Never operate the chain saw without sufficient chain lubrication as this might damage the saw and is a threat to safety. Check the chain lubricant level before each use!

In order to prevent kickback, please follow these safety instructions:

- Never cut with the tip of the guide bar! Be careful when continuing from previous cuts.
- Always start cutting only when the chain saw is already running.
- Make sure that the saw chain is always properly sharpened.
- Never cut through more than one branch at a time! When lopping off branches, be careful not to touch any other branches.
- When cross-cutting, pay attention to trunks standing very close to each other. If possible, use a sawing trestle.

### HOLDING THE CHAIN SAW

See figure 8

Always hold the chain saw with your right hand at the rear handle and your left hand at the front handle. Grip both handles with the thumbs and fingers encircling the handles. Ensure that your left hand is holding the front handle so that your thumb is underneath.

### STARTING OPERATION

- Before operation, ensure that the battery is charged and correctly installed.
- To start the machine: Pull the Safety lock-out button (item 4), and then pull the switch trigger (item 5).

### STOPPING OPERATION

- Release the power switch trigger (item 5) to stop the chain saw.

### USING THE CHAIN SAW

Always be sure of your footing and hold the chain saw firmly with both hands while the motor is running.

### BASIC FELLING, LIMBING, AND CROSS-CUTTING TECHNIQUES

See figure 9

#### FELLING A TREE

When bucking and felling operations are being performed by two or more persons at the same time, the felling operation should be separated from the bucking operation by a distance of at least twice the height of the tree being felled. Trees should not be felled in a manner that would endanger any person, strike any utility line or cause any property damage. If the tree does make contact with

any utility line, the utility company should be notified immediately.

The chain saw operator should keep on the uphill side of the terrain as the tree is likely to roll or slide downhill after it is felled.

An escape path should be planned and cleared as necessary before cuts are started. The escape path should extend back and diagonally to the rear of the expected line of fall.

Before felling is started, consider the natural lean of the tree, the location of larger branches and the wind direction to judge which way the tree will fall.

Remove dirt, stones, loose bark, nails, and staples from the tree.

#### NOTCHING UNDERCUT (A NOTCH CUT IN A TREE TO DIRECT THE FALL)

See Figure 10

Make the notch 1/3 in diameter of the tree, perpendicular to the direction of falls. Make the lower horizontal notching cut first, this will help to avoid pinching of either the saw chain or the guide bar when the second notch is being made.

#### FELLING BACK CUT (THE FINAL CUT IN A TREE FELLING OPERATION, MADE ON THE OPPOSITE SIDE OF THE TREE FROM THE NOTCHING UNDERCUT)

See Figure 10

Make the felling back cut at least 50mm higher than the horizontal notching cut. Keep the felling back cut parallel to the horizontal notching cut. Make the felling back cut so as to leave enough wood to act as a hinge. The hinge wood keeps the tree from twisting and falling in the wrong direction. Do not cut through the hinge. As the felling cut gets close to the hinge, the tree should begin to fall. If there is any chance that the tree may not fall in the desired direction or it may rock back and bind the saw chain, stop cutting before the felling back cut is complete and use wedges of wood, plastic or aluminium to open the cut and drop the tree along the desired line of fall. When the tree begins to fall, remove the chain saw from the cut, **release the power trigger to stop the chain saw, put the chain saw down, and then use the retreat path as planned. Be alert of overhead limbs falling and watch your footing.**

#### LIMBING A TREE

See figure 11

Limbing is removing the branches from a fallen tree. When limbing, leave the larger lower limbs to support the log off the ground. Remove the small limbs in one cut. Branches under tension should be cut from the bottom up, to avoid binding the chain saw.

#### BUCKING A LOG

See figure 12 - 15

## English (Original Instructions)

Bucking is cutting a log into lengths. It is important to make sure your footing is firm and your weight is evenly distributed on both feet. When possible, the log should be raised and supported by the use of limbs, logs or chocks.

Follow the simple direction for easy cutting:

1. When the log is supported along the entire length, it is cut from the top (over buck).
2. When the log is supported on one end, cut 1/3 of the diameter from the underside (under buck). Then make the finished cut by over bucking to meet the first cut.
3. When the log is supported on both ends, cut 1/3 of that diameter from the top (over buck). Then make the finished cut by under bucking the lower 2/3 to meet the first cut.
4. When bucking on a slope, always stand on the uphill side of the log. When cutting through, to maintain complete control, release the cutting pressure near the end of the cut without relaxing your grip on the chain saw handles.

Do not let the chain contact the ground. After completing the cut, wait for the saw chain to stop before you move the chain saw. Always stop the motor before moving from tree to tree.

### MAINTENANCE

#### WARNING

Always remove the battery pack from the machine before checking the chain tension or making adjustments to the chain. Wear protective gloves while touching the chain, bar or areas around the chain.

### ADJUSTING THE CHAIN TENSION

See *figure 2*

- Un-tighten the sprocket cover **securing** knob (item 15) slightly by turning it counterclockwise.
- To increase the chain tension, turn the chain tensioner adjustment knob (item 13) clockwise and check the chain tension frequently. To reduce the chain tension, turn the chain tensioner adjustment knob (item 13) counterclockwise and check the chain tension frequently.
- The chain tension is correct when the gap between the cutter in the chain and the bar is between 3mm-4mm. Pull the chain in the middle of the lower side of the bar downwards (away from the bar) and measure the distance between the bar and the chain cutters.
- Tighten the sprocket cover **securing** knob (item 15) by turning it clockwise.

### REPLACING THE BAR AND CHAIN

See *Figure 2, 3, 5, 7*

- Put the saw down on a flat and even surface to make

adjustments to the chain.

- Make sure that you have the correct replacement bar and chain as advised earlier in the specification section of this manual.
- Unscrew the sprocket cover **securing** knob (item 15) by turning it counterclockwise until the sprocket cover (item 14) comes loose.
- Remove the sprocket cover. Remove the bar and saw chain from unit.
- To replace the bar with the new one, unscrew the nut of the safety tip, mount the safety tip on to the new bar and tighten the nut.
- Put the new chain in the correct direction as shown in figure 7 onto the bar and make sure that the drive links are aligned in the bar groove (figure 5).
- Attach the bar to the chain saw and loop the chain around the drive sprocket as shown in figure 3.
- Replace the sprocket cover (item 14), tighten sprocket cover and tighten knob (item 15).
- Follow the steps the section “ADJUSTING THE CHAIN TENSION” earlier in this manual.

### ADDING CHAIN & BAR LUBRICANT

- Unscrew and remove the cap (item 6) from the oil tank.
- Pour the oil into the oil tank and monitor the oil level gauge (item 7). Ensure that no dirt enters the oil tank while filling the oil in.
- Put the oil cap back on and tighten it up.
- One full oil tank will enable you to use the saw for 20-40 min.

### TRANSPORTING THE CHAIN SAW

Before transporting the chain saw, always remove the battery pack from the chain saw and slide the chain cover over the bar and chain. If several cuts are to be performed with the chain saw, the saw must be switch off between cuts.

### GUIDE BAR COVER

See *figure 1*

The chain cover must be clipped onto the chain and bar as soon as the sawing work has been completed and whenever the machine has to be transported.

### SHARPENING THE SAW CHAIN

See *figure 16 - 21*

When the chain penetrates into wood with difficulty, it needs sharpening as follows:

- Put the chain under tension.
- Fasten the bar in a vice so that the chain can slide.
- Fasten the file to the file holder and place it on cutter at 35° angle.

## English (Original Instructions)

- File with forward strokes only until all the worn out parts of the cutting edge are taken away.
- Count the number of strokes given to the cutter as a reference and file away with the same number of strokes on all other cutters.
- If the depth gauge protrudes from the template after sharpening a few times, reset its level. Use a flat file.
- Finally, round off the depth gauge.

**NOTE:** It is recommended to have the deep or important sharpening carried out by a service agent who is equipped with electric sharpener.

### GUIDE BAR MAINTENANCE

- When you have finished working, clean out the groove and the oil passages with a scraping hook.
- Periodically trim the sides of rails using a flat file. If not done in the long run, the feather edges might break away and damage the bar.
- If one rail is higher than the other one, it is necessary to make it even with a flat file then smooth it with a file or fine grain abrasive paper.

#### **⚠ WARNING**

When servicing, use only identical replacement parts. Use of any other parts may create a hazard or cause product damage.

#### **⚠ WARNING**

To avoid serious personal injury, always remove the battery pack from the tool when cleaning or performing any maintenance.

### GENERAL MAINTENANCE

Before each use, inspect the entire product for damaged, missing, or loose parts such as screws, nuts, bolts, caps, etc. Tighten securely all fasteners and caps and do not operate this product until all missing or damaged parts are replaced. Please call Ryobi Customer Service for assistance.

Avoid using solvents when cleaning plastic parts. Most plastics are susceptible to damage from various types of commercial solvents and may be damaged by their use. Use clean cloths to remove dirt, dust, oil, grease, etc.

#### **⚠ WARNING**

Do not at any time let brake fluids, gasoline, petroleum-based products, penetrating oils, etc., come in contact with plastic parts. Chemicals can damage, weaken or destroy plastic which may result in serious personal injury.

Only the chain and bar are intended to be serviced or replaced by the operator. All other parts should be replaced at an Authorised Service Centre. For your nearest Ryobi Authorised Service Centre call 1300 361 505 or visit the website [www.ryobi.com.au](http://www.ryobi.com.au)

### STORAGE

#### STORING THE PRODUCT

- Remove the battery pack from the unit before storing.
- Clean all foreign material from the unit.
- Store it in a place that is inaccessible to children.
- Keep away from corrosive agents such as garden chemicals and de-icing salts.
- Store and charge your batteries in a cool area. Temperatures above or below normal room temperature will shorten battery pack life.
- Never store batteries in a discharged condition. Store battery packs in a 30%-50% charged condition.
- Store the battery pack where the temperature is below 27°C and away from moisture.
- All batteries gradually lose their charge. The higher the temperature, the quicker they lose their charge. If you store your unit for long periods of time without using it, charge the pack as normal every six months of storage. This practice will prolong battery pack life.

### DISPOSAL



Power tools and accessories contain large amount of valuable resources and plastics that can be recycled. Waste electrical products should not be disposed of together with household waste. Please recycle where facilities exist. Check with your local authority or retailer for recycling advice.

The battery contains material which is hazardous to you and the environment. It must be removed and disposed of separately at a facility that accepts lithium-ion batteries.

**TECHTRONIC INDUSTRIES AUSTRALIA PTY LIMITED**

**GUARANTEE**



Subject to the guarantee condition below, this Ryobi tool (hereinafter called "the product") is guaranteed by TECHTRONIC INDUSTRIES AUSTRALIA PTY LIMITED (hereinafter called "the Company") to be free from defects in material or workmanship for a period of 24 months from the date of original purchase covering both parts and labour. Under the terms of this guarantee, the repair or replacement of any part shall be the opinion of the Company or its authorised service centre. Should service become necessary during the warranty period, the owner should contact the customer service HELPLINE 1300 361 505 or contact the retailer from whom the product was purchased.

In order to obtain guarantee service, the owner must present the sales docket and Guarantee Certificate to confirm date of purchase. This product is sold by the dealer or service centre as principal and the dealer has no authority from the Company's behalf except as herein contained or herein referred to.

**Guarantee Conditions**

This guarantee only applies provided that the product has been used in accordance with the manufacturer's recommendations under normal use and reasonable care (in the opinion of the Company) and such

guarantee does not cover damage, malfunction or failure resulting from misuse, neglect, abuse, or used for a purpose for which it was not designed or is not suited and no repairs, alterations or modifications have been attempted by other than an authorised service centre. This guarantee will not apply if the tool is damaged by accident or if repairs arise from normal wear and tear. The Company accepts no additional liability pursuant to this guarantee for the costs of travelling or transportation of the product or parts to and from the service dealer or service centre - such costs are not included in this guarantee.

Certain legislation, including the Trade Practices Act, 1974 (as amended) and other state and territorial laws give rights to the buyer and impose liability on the seller in certain circumstances. Nothing herein shall have the effect of excluding, restricting or modifying any condition, guarantee, right or liability imposed, to the extent only that such exclusion, restriction or modification would render any term herein void.



**TECHTRONIC INDUSTRIES (AUSTRALIA) PTY. LTD.**

Level 1, 660 Doncaster Road,  
Doncaster, Victoria 3108,  
Australia

Tel: 1300 361 505 Fax: 1800 807 993  
[www.ryobi.com.au](http://www.ryobi.com.au)

**TECHTRONIC INDUSTRIES N.Z. LIMITED**

Auckland: 27 Clemow Drive, Mt Wellington, N.Z.

Tel: (09) 573 0230 Free Call: 0800 279 624 Fax: (09) 573 0231  
Contact during normal business hours.

[www.ryobi.co.nz](http://www.ryobi.co.nz)

**This Guarantee Form Should Be Retained By The Customer At All Times**

For your record and to assist in establishing date of purchase (necessary for in-guarantee service) please keep your purchase docket and this form completed with the following particulars.

Purchased From \_\_\_\_\_

Address Of Dealer \_\_\_\_\_

Date \_\_\_\_\_ Model No \_\_\_\_\_ Serial No \_\_\_\_\_

Present This Form With Your Purchase Docket When Guarantee Service Is Required.