



**SAMSUNG**

# USER MANUAL

HMX-H400BP/HMX-H405BP

[www.samsung.com/register](http://www.samsung.com/register)





**For video recording, use a memory card that supports faster write speeds.**

- Recommended Memory Card: 6MB/s (Class 6) or above.

# Before reading this user manual

## SAFETY WARNINGS

What the icons and signs in this user manual mean;

 <b>WARNING</b>	There is a potential risk of death or serious injury.
 <b>CAUTION</b>	There is a potential risk of personal injury or damage to the product.
	To reduce the risk of fire, explosion, electric shock, or personal injury when using your camcorder, follow these basic safety precautions.
	Here are hints or page number references you will find helpful when you operate the camcorder.
	Settings required before using a function.

These warning signs are here to prevent injury to you and others. Please follow them explicitly. After reading this section, keep it in a safe place for future reference.

## PRECAUTIONS

### Warning!

- When using the AC power adaptor with your camcorder, connect the adaptor to an outlet with protective grounding.
- Do not expose the camcorder battery to direct sunlight, heaters, radiators, fire, or any other source of excessive heat.

### Caution

If you replace the battery with the wrong battery, you can cause an explosion. Replace only with the same battery or an equivalent type.

To disconnect the apparatus from the mains, the plug must be pulled out from the mains socket, therefore the mains plug shall be readily operable.

## IMPORTANT INFORMATION ON USE

### About this user manual

Thank you for purchasing this Samsung Camcorder. Please read this user manual carefully before you use the camcorder and keep it handy for future reference. Should your camcorder fail to operate correctly, refer to Troubleshooting.

### This User Manual covers HMX-H400, HMX-H405 models.

- Illustrations of model HMX-H400 are used in this user manual.
- The displays in this user manual may not be exactly the same as those you see on the LCD screen.
- Designs and specifications of the camcorder and other accessories are subject to change without any notice.
- In this user manual, the icon or symbol in the parenthesis appearing in a description of a submenu item indicates it will appear on the screen when setting the corresponding item.  
Ex) Submenu item of **"Video Quality"** → page 54
  - **"Super Fine"** (Ⓢ): Records in the Super Fine quality. (If set, the corresponding icon (Ⓢ) will appear on the screen.)

### The following terms are used in this manual:

- 'Scene' refers to the point where you press the **Record Start/Stop** button to start recording until you press again to pause the recording.
- The terms 'photo' and 'still image' are used interchangeably and have the same meaning.

### Before using this camcorder

- **This camcorder records video in H.264 (MPEG4 part10/AVC) format and in High Definition Video (HD-VIDEO) or Standard Definition Video (SD-VIDEO).**
- **You can play back and edit the video recorded by the camcorder on a personal computer using the internal software of this camcorder.**
- **Please note that this camcorder is not compatible with other digital video formats.**
- **Before recording important video, make a trial recording.**  
Play back your trial recording to make sure the video and audio have been recorded properly.
- Recorded contents may be lost due to a mistake when handling this camcorder or memory card, etc. Samsung will not provide compensation for damages due to the loss of recorded contents.
- **Make a backup of important recorded data.**  
Protect your important recorded data by copying the files to a PC. We also recommend you copy it from your PC to other recording media for storage. Refer to the software installation and USB connection guide.
- **Copyrights: Please note that this camcorder is intended for individual use only.**  
Data recorded on the storage media in this camcorder using other digital/analogue media or devices is protected by the Copyright Act and cannot be used without permission of the owner of the copyright, except for personal enjoyment. Even if you record an event such as a show, performance, or exhibition for personal enjoyment, we strongly recommend that you obtain permission beforehand.
- For Open Source licenses information, refer to the "Opensource-H400.pdf" in the provided CD-ROM.

### Notes regarding trademarks

- All the trade names and registered trademarks mentioned in this manual or other documentation provided with your Samsung product are trademarks or registered trademarks of their respective holders. Furthermore, "™" and "®" are not mentioned in each case in this manual.
- The SD, SDHC logos are trademarks.
- Microsoft®, Windows®, Windows Vista®, Windows® 7, and DirectX® are either registered trademarks or trademarks of the Microsoft Corporation in the United States and/or other countries.
- Intel®, Core™, Core 2 Duo®, and Pentium® are the registered trademarks or trademarks of the Intel Corporation in the United States and other countries.
- AMD and Athlon™ are either registered trademarks or trademarks of AMD in the United States and other countries.
- Macintosh, Mac OS are either registered trademarks or trademarks of Apple Inc. in the United States and/or other countries.
- YouTube is a trademark of Google Inc.
- Flickr is a trademark of Yahoo.
- twitter is a trademark of Twitter.
- Picasa is a trademark of Google Inc.
- Facebook is a trademark of Facebook Inc.
- HDMI, the HDMI logo and High-Definition Multimedia Interface are trademarks or registered trademarks of HDMI Licensing LLC.
- Adobe, the Adobe logo, and Adobe Acrobat are either registered trademarks or trademarks of Adobe Systems Incorporated in the United States and/or other countries.

# Safety information

The safety precautions illustrated below are to prevent personal injury or material damages. Heed all instructions carefully.



**WARNING** There is a potential risk of death or serious injury.



Do not overload outlets or extension cords as this may result in abnormal heat or fire.



Using the camcorder at temperatures over 140°F (60°C) may result in fire. Keeping the battery at a high temperature may cause an explosion.



Do not allow water, metal or inflammable matter to enter the camcorder or AC power adaptor. Doing so may pose a fire hazard.



No sand or dust! Fine sand or dust entering the camcorder or AC power adaptor can damage both units and cause them to malfunction.



No oil! Oil entering the camcorder or AC power adaptor can damage both units, cause them to malfunction, and poses a risk of electric shock.



Do not aim the camcorder directly into the sun. Doing so could cause eye injuries and cause internal parts of the product to malfunction.



Do not bend the power cord or damage the AC power adaptor by pressing on it with a heavy object. A damaged power cord or power supply can cause a fire and poses a risk of electric shock.



Do not disconnect the AC adaptor by pulling on its power-cord. This can damage the power-cord.



Do not use the AC adaptor if it has damaged, split, or broken cords or wires. A damaged power cord can cause a fire and poses a risk of electric shock.



**WARNING** There is a potential risk of death or serious injury.



Do not plug in the AC adaptor unless the plug can be fully inserted into the wall outlet with no part of the blades exposed.



Do not dispose of the battery in a fire. The heat from the fire could cause the battery to explode.



Never use cleaning fluid or similar chemicals to clean the camcorder. Do not spray cleaners directly on the camcorder. Doing so may pose a fire hazard.



Keep the camcorder away from water when using it near the beach or pool or when it rains. Getting water inside the camcorder can cause it to malfunction and poses a risk of electric shock.



Do not plug in or unplug the power cord with wet hands. You could receive an electric shock.



Keep the used lithium battery or memory card out of the reach of children. If the lithium battery or memory card is swallowed by a child, consult a physician immediately.



Keep the power supply's power-cord unplugged when not using the power supply or during lightning storms. There is a risk of fire.



When cleaning the AC adaptor, unplug the power-cord. Leaving the adaptor plugged in can cause it to malfunction and poses a risk electric shock.



If the camcorder emits an abnormal sound or smell or smokes, unplug the power-cord immediately and request service from a Samsung service centre. There is a risk of fire or personal injury.



If the camcorder malfunctions, immediately detach the AC adaptor or battery from the camcorder. There is a risk of fire or injury.



To avoid a risk of fire or electric shock, do not attempt to disassemble, repair, or modify the camcorder or the AC adaptor.



**CAUTION** There is a potential risk of personal injury or damage to the product.



Do not press the surface of the LCD with force, or hit it with a sharp object. If you press or strike the LCD surface, you can cause display unevenness or damage the display.



Do not drop or expose the camcorder, battery, AC adaptor, or other accessories to severe vibrations or impact. Severe vibration or impact can cause these items to malfunction and lead to personal injury.



Do not use the camcorder on a tripod (not supplied) in a place where it is subject to severe vibrations or impact.



Do not use the camcorder in direct sunlight or near heating equipment. Excess heat can cause the camcorder to malfunction and lead to personal injury.



Do not leave the camcorder in a closed vehicle for a long time where the temperature is very high.



Do not expose the camcorder to soot or steam. Thick soot or steam could damage the camcorder case or cause a malfunction.



Do not use the camcorder near dense exhaust gas generated by gasoline or diesel engines, or near a corrosive gas such as hydrogen sulfide. Doing so may corrode the external or internal terminals, disabling normal operation.



Do not expose the camcorder to insecticide. Insecticide entering the camcorder could cause the product to operate abnormally. Turn the camcorder off and cover it with vinyl sheet, etc. before using insecticide.



Do not expose the camcorder to sudden changes in temperature or high humidity. Use care when operating the camcorder outdoors during a lightning storm. Rapid temperature changes and high humidity can damage the camcorder and lightning storms pose the threat of electric shock.



Do not put the camcorder down with the LCD screen open.



Do not wipe the camcorder body with benzene or thinner. The exterior coating could peel off or the surface could deteriorate.



Do not leave the LCD screen open when not using the camcorder.



**CAUTION** There is a potential risk of personal injury or damage to the product.



Do not hold the camcorder by the LCD monitor when lifting it. The LCD screen could detach and the camcorder may fall.



Do not use the camcorder near a TV or radio: This could cause distortion on the TV screen or interference in the radio broadcasts.



Do not use the camcorder near sources of strong radio waves or magnetism such as speakers or large motors. Noise from these sources could distort the video or audio you are recording.



Use Samsung-approved accessories only. Using products from other manufacturers may lead to overheating, fire, explosion, electric shock or personal injuries caused by abnormal operation.



Place the camcorder on a stable surface that is well ventilated.



Store important data separately from the camcorder on a PC, DVD disc, CD disc, etc. Samsung is not responsible for data loss.



Only plug the adaptor plug into a socket that is easily accessible. If any problem occurs with the product, you must pull the plug out of the socket to disconnect the power completely. Turning off the power button on the product does not completely disconnect the power.



Manufacturers of unauthorized accessories compatible with this camcorder are responsible for their own products. Use the optional accessories according to their safety instructions. Samsung is not responsible for any malfunctions, for fires or electric shocks, or for damage caused by unauthorised accessories.

# Contents

---

Before reading this user manual .....	2	Basic operation of the camcorder.....	27
Safety warnings.....	2	Turning your camcorder on/off .....	27
Precautions .....	2	Adjusting the LCD screen.....	28
Important information on use.....	2	Setting the operation modes.....	29
		Using the display(□) button .....	29
		Using the touch panel.....	30
Safety information.....	4		
Warning.....	4	First time settings.....	31
Caution.....	6	Setting the time zone and date/time for the first time .....	31
		Selecting the languages.....	32
Contents.....	8		
		About the storage media.....	33
Quick start guide .....	11	Selecting the storage media (HMX-H405 only) .....	33
You can record videos in H.264 format!.....	11	Inserting / ejecting a memory card (not supplied) .....	34
		Selecting a suitable memory card (not supplied) .....	35
Getting to know the camcorder .....	15	Recordable time and capacity .....	37
What's included with your camcorder.....	15		
Location of controls.....	16	Basic recording .....	38
Identifying the screen displays .....	18	Recording videos.....	38
		Tagging great moments while recording (My Clip function) .....	40
Getting started .....	21	Recording photos.....	41
Attaching the grip belt.....	21	Recording with ease for beginners (SMART AUTO).....	42
Attaching the ferrite core.....	21	Zooming.....	43
Using the battery .....	22	Anti-Shake (OIS: Optical Image Stabiliser).....	44
Charging the battery.....	23		
Checking the battery state.....	24		

<b>Basic playback</b> .....	45	Self Timer .....	64
Changing the playback mode .....	45	Art Time Lapse REC .....	64
Playing videos .....	46	Quick View .....	67
Viewing photos.....	48	Guideline .....	68
<b>Using the menu items</b> .....	50	<b>Advanced playback</b> .....	68
Handling menus .....	50	Play Option.....	68
Menu items.....	51	Highlight .....	69
 		Slide Show Option.....	70
<b>Advanced recording</b> .....	53	File Info.....	70
SCENE.....	53	 	
Video Resolution.....	53	<b>Editing files</b> .....	71
Video Quality .....	54	Delete.....	71
Photo Resolution .....	54	Delete My Clip .....	72
Photo Sharpness.....	55	My Clip Creation.....	72
White Balance .....	55	Protect .....	73
Aperture .....	56	Copy (HMX-H405 only).....	74
Shutter .....	57	Divide .....	75
EV .....	58	Combine .....	76
Super C.Nite.....	58		
Focus .....	59		
Digital Effect .....	60		
Fader.....	61		
Tele Macro .....	62		
Cont. Shot.....	62		
Wind Cut.....	63		
Digital Zoom .....	63		

System setting .....	77	Connecting to a TV .....	90
Setting Menu Items.....	77	Connecting to a high definition TV with HDMI .....	90
Storage Type (HMX-H405 only) .....	78	Connecting to a regular TV .....	91
Storage Info (HMX-H405 only) .....	78	Viewing on a TV screen .....	92
Card Info (HMX-H400 only).....	78	Dubbing videos .....	93
File No.....	79	Dubbing to a VCR or DVD/HDD recorder.....	93
Time Zone .....	79	Printing photos .....	94
Date/time Set .....	80	Direct printing with a pictbridge printer.....	94
Date Type.....	80	Using with a Windows computer .....	96
Time Type .....	80	What you can do with a windows computer .....	96
Date/Time Display .....	81	Using the intelli-studio program .....	97
Auto LCD Off.....	82	Using as a removable storage device.....	101
Beep Sound .....	83	Troubleshooting.....	103
Shutter Sound .....	83	Warning indicators and messages .....	103
Auto Power Off .....	84	Symptoms and solutions .....	108
Quick On STBY .....	84	Maintenance & additional information.....	114
PC Software .....	85	Maintenance.....	114
USB Connect .....	86	Using your camcorder abroad .....	115
HDMI TV Out .....	86	Glossary .....	116
TV Connect Guide.....	87	Specifications.....	117
TV Display .....	87		
Format.....	88		
Default Set.....	88		
Language .....	88		
Demo .....	89		
Anynet+ (HDMI-CEC).....	89		

# Quick start guide

This quick start guide introduces the basic operation and features of your camcorder. See the reference pages for more information.

## You can record videos in H.264 format!

You can record videos in H.264 format that is convenient to email and share with your friends and family.  
You can also take photos with your camcorder.

### STEP 1: Get ready

1. Attach the battery to the camcorder. [page 22](#)
  - Align the battery with the indicator (▲) on the battery compartment, and then push the battery in the direction of the arrow.
2. Charge the battery fully. [page 23](#)
  - The battery is fully charged when the CHG (charging) indicator light turns green.
3. Insert a memory card. [page 34](#)
  - You can use commercially available SDHC (SD High Capacity) or SD memory cards with this camcorder.
  - Set the appropriate storage media. (HMX-H405 only) [page 33](#)

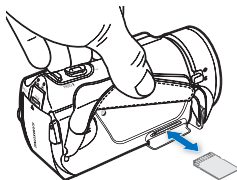
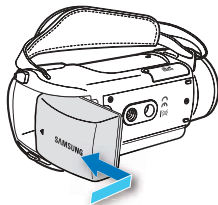

### STEP2: Record with your camcorder

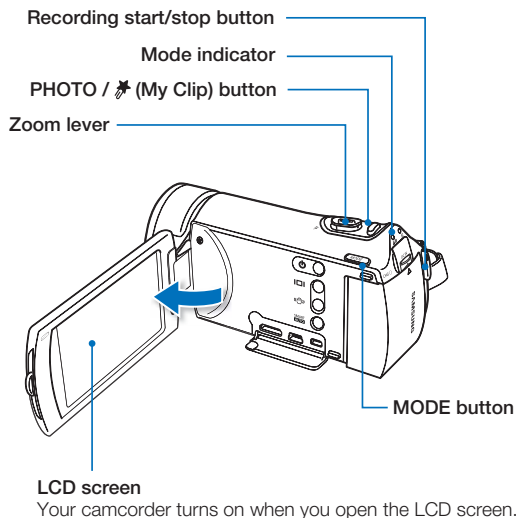

## Recording videos

Your camcorder uses advanced H.264 compression technology to give you the clearest video quality.

1. Open the LCD screen.
2. Press the **Recording start/stop** button.
3. To stop recording, press the **Recording start/stop** button.

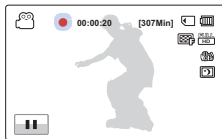

## Recording photos

Your camcorder can record high quality photos with a 16:9 aspect ratio.

1. Open the LCD screen.
2. Press the **PHOTO / (My Clip)** button lightly to adjust the focus.
3. Fully press the **PHOTO / (My Clip)** button when the subject is in focus.

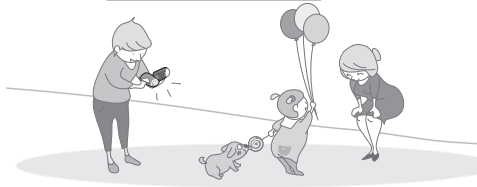
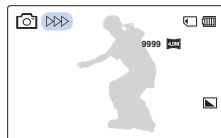

Using 'Quick On STBY' by opening/closing the LCD screen.

When you close the LCD screen during standby, your camcorder goes to Quick On STBY mode (power saving mode). You can start recording quickly when you open the LCD screen. [page 84](#)







The default video resolution setting is "1080/50". You can also record videos in SD (standard definition) video quality.

## STEP3: Play back videos or photos

### Viewing videos or photos on the LCD screen

You can find recordings quickly by using the thumbnail index view.

1. Touch the Play () tab on the screen in STBY mode.
  - The thumbnail index view appears. The thumbnail of the latest created or played file is highlighted.
2. Touch the thumbnail ( /  / ) tab, then touch the desired image.

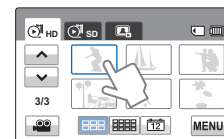
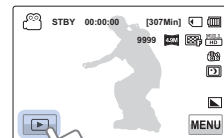

### Viewing on a high definition TV

You can enjoy HD (high definition) videos on an HDTV. ➔page 90



You can also play back videos on an SD (standard definition) image quality TV. ➔page 91



## STEP4: Save recorded videos or photos

**Simple and fun! Enjoy the various features of the internal Intelli-studio programme on your Windows computer.**

Using the Intelli-studio programme built in your camcorder, you can import video/photos into your computer, edit or share the videos/photos with your friends and family. For details, see pages 97~100.

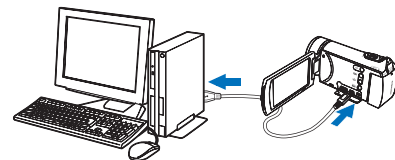

## Importing and viewing videos/photos from the camcorder to your PC

1. Launch the Intelli-studio programme by connecting the camcorder to your PC with a USB cable.
  - A new file saving screen appears with the Intelli-studio main window. Click **“Yes”**, and the uploading procedure starts.
2. The new files are saved to your PC and registered to **“Contents Manager”** on the Intelli-studio programme.
  - You can arrange the files by different criteria such as Face, Date, etc.
3. Double-click on the file you would like to playback.

Contents Manager    Saved files into your PC



Folders directory on your PC

## Sharing videos/photos on YouTube/Flickr/FaceBook

Share your contents with the world by uploading videos and photos directly to a web site with one click.

Click **“Share”** → **“Upload”** tab on the browser. ↪ page 100



The Intelli-studio runs automatically once the camcorder is connected to a Windows computer (when you specify **“PC Software:On”**) ↪ page 85

## STEP5: Delete videos or photos

If the camcorder’s storage media is full, you cannot record new videos or photos. Delete videos or photos that you have saved to a computer from the camcorder’s storage media. Then you can record new videos or photos on newly freed up space.

Touch the **Play** (⏮) tab → **Menu** (☰) tab → **“Delete”** on the LCD screen. ↪ page 71

# Getting to know the camcorder

## WHAT'S INCLUDED WITH YOUR CAMCORDER

Your new camcorder comes with the following accessories. If any of these items is missing from your box, call Samsung's Customer Care centre.



Model name	Internal Memory	Colour	Lens
HMX-H400BP	-	Black	30x (Optical) 45x (Digital)
HMX-H405BP	32GB		

- Although some features of the models are different, they operate in the same way.

## Checking your accessories



**Battery**  
(IA-BP210R)



**AC power adaptor**  
(AA-MA9 type)



**USB cable**



**User manual CD**

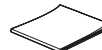

**Quick start guide**

## Optional accessories



**Mini HDMI cable**



**Audio/Video cable**



**Carrying case**  
(IA-CC1U27B)



**Ferrite Core**



**Memory card**



- The exact appearance of each item may vary by model.
- The contents may vary depending on the sales region.
- Parts and accessories can be purchased after consulting with your local Samsung dealer. SAMSUNG is not responsible for reduced battery life time or malfunctions caused by any unauthorised use of accessories such as the AC power adaptor or the batteries.
- You can purchase additional batteries (IA-BP210E/IA-BP420E) from Samsung authorised service centre.
- A memory card is not included. See page 35 for memory cards compatible with your camcorder.
- Your camcorder includes the user manual CD and the printed quick start guide.

## LOCATION OF CONTROLS

## Front &amp; Left

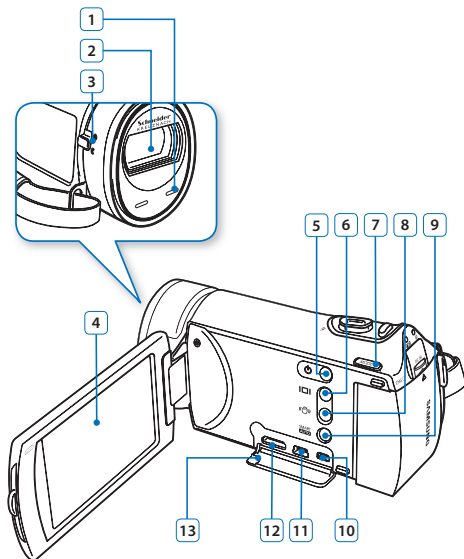

- |    |                               |
|----|-------------------------------|
| 1  | Internal microphone           |
| 2  | Lens                          |
| 3  | Lens open/close switch        |
| 4  | TFT LCD screen (Touch screen) |
| 5  | Power button                  |
| 6  | Display button                |
| 7  | MODE button                   |
| 8  | Anti-shake (OIS) button       |
| 9  | SMART <b>AUTO</b> button      |
| 10 | AV(Audio/Video) jack          |
| 11 | USB jack                      |
| 12 | HDMI jack                     |
| 13 | Jack cover (HDMI,USB,AV)      |

 During a recording, be careful not to block the internal microphone and lens.

### Right Top & Bottom

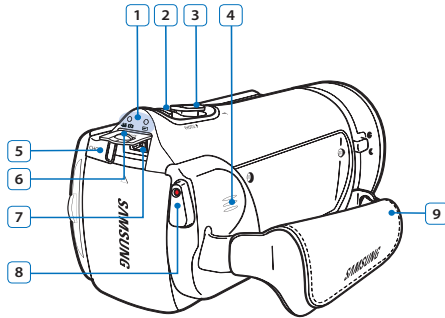



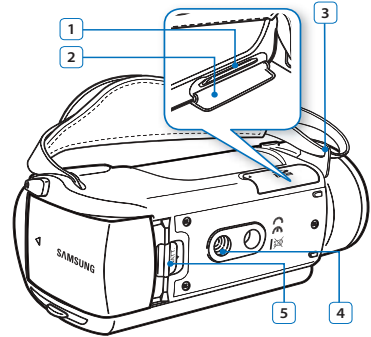

- 1** Mode indicator
  - : Record mode (Video/Photo)
  - : Play mode
- 2** PHOTO / (My Clip) button
- 3** Zoom (W/T) lever
- 4** Internal speaker
- 5** Charging (CHG) indicator
- 6** Jack cover (DC IN)
- 7** DC IN jack
- 8** Recording start/stop button
- 9** Grip belt



- 1** Memory card slot
- 2** Memory card cover
- 3** Grip belt hook
- 4** Tripod receptacle
- 5** Battery release switch

## IDENTIFYING THE SCREEN DISPLAYS

The available functions vary depending on the operation mode you've selected. Different indicators appear depending on the setting values.





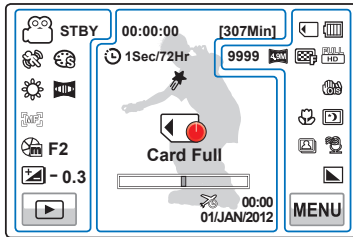













-  This On Screen Display (OSD) is shown in the record (   ) mode only.
- Select the record mode by pressing the **MODE** button.  page 29

### Record mode







-  Settings of functions marked with \* are not retained when the camcorder is turned off. (Settings of Aperture, Shutter, Focus are not retained when the operating mode is switched.)
- The on-screen indicators are based on an 32GB SDHC memory card capacity.
- For warning indicators and messages, see pages 103–107.
- The illustrated items above and their positions can be changed without notice to improve performance.
- The total number of recordable photos is based on available space on the storage media.
- The largest number the OSD Image Counter can display is "9,999".
- This camcorder provides one record mode which combines the video and photo record modes. You can easily record videos or photos in the same mode without having to change it.

### Left of the LCD screen















Indicator	Meaning
 /  / 	Record mode (Video/Photo) / Smart Auto
STBY /  /  / 	Operating status (standby/ recording/Pause) / Self Timer*
 / 	SCENE, Digital Effect
 / 	White Balance, Fader*
 / 	Manual focus* / Touch Point*
 F2 /  S.1/50	Manual aperture* / Manual shutter*
 - 0.3	EV (Exposure Value)*
 /  /  / 	Play tab / Pause tab / Stop tab, Rec tab

### Centre of the LCD screen

Indicator	Meaning
00:00:00	Time counter (video recording time)
	Warning indicators and messages
[307Min]	Remaining recordable time

Indicator	Meaning
	Optical zoom / Digital zoom bar
	Time Zone (visit)
00:00 01/JAN/2012	Date/Time
	Art Time Lapse REC*
	My Clip

### Right of the LCD screen

Indicator	Meaning
 / 	Storage media (Memory card or internal memory) (HMX-H405 only)
	Battery info. (remaining charge level)
9999,  / 	Image counter (total number of recordable photo images), Photo Resolution, Video Quality, Video Resolution
 /  / 	Anti-shake(OIS)/Anti-shake(OIS DUO)/Anti-shake(OIS DUO+)
 / 	Tele Macro*, Super C.Nite
 / 	Cont. Shot, Wind Cut*
	Photo Sharpness
	Menu tab

- This On Screen Display (OSD) is shown in video play (CAM/HD/CAMSD) mode only.
- Select the Play (CAM) tab on the LCD screen to select the video play (CAM/HD/CAMSD) mode. → page 45

## Video play mode

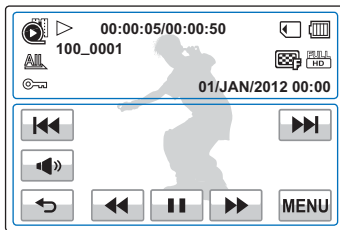

- The play related tab, the volume control, and the return tab appear briefly on the screen. They reappear when you touch the screen anywhere.
- For warning indicators and messages, see pages 103–107.

### Top of the LCD screen

Indicator	Meaning
	Video play mode
	Operating status (play/pause)
00:00:05/00:00:50	Playback time/recorded time
	Storage media (Memory card or internal memory) (HMX-H405 only)
	Battery info. (remaining charge level)
	Play Option
100_0001	File name (file number)
	Video Quality, Video Resolution
	Protect
01/JAN/2012 00:00	Date/Time

### Bottom of the LCD screen

Indicator	Meaning
	Volume control
	Volume tab / Play related function tab (frame advance)
	Return tab
	Play related function tab (skip/ search/pause/ playback/slow playback)
	Menu tab

- ☑ This On Screen Display (OSD) is shown in photo play (🖼️) mode only.
- Select the Play (▶️) tab on the LCD screen to select the photo play (🖼️) mode. ➡ page 45

## Photo play mode

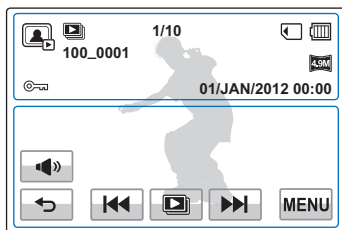

### Top of the LCD screen

Indicator	Meaning
	Photo play mode
	Slide show / Playback zoom (X1.1~X8.0)
100_0001	File name (file number)
1/10	Photo image counter (current image / total number of recorded images)
	Storage media (Memory card or internal memory) (HMX-H405 only)
	Battery info.
	Erase protection
	Photo resolution
01/JAN/2012 00:00	Date/Time

### Bottom of the LCD screen

Indicator	Meaning
	Volume tab (when activating slide show)
	Return tab
	Previous image/Next image tab
	Slide show start tab
	Menu tab

# Getting started

## ATTACHING THE GRIP BELT

Adjust the length of grip belt so that the camcorder is stable when you press the **Recording start/stop** button with your thumb.

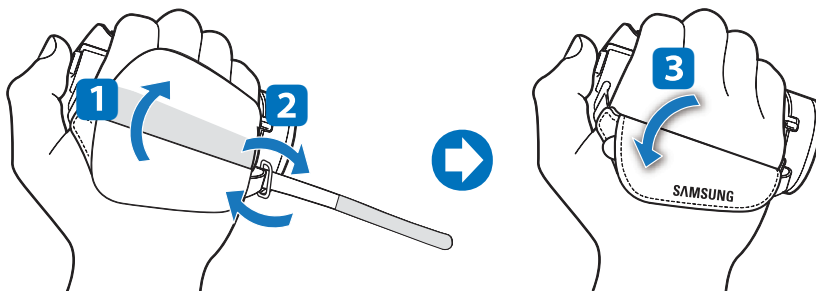

 If you make the grip belt too tight and use excessive force to insert your hand, the grip belt hook of the camcorder may be damaged.

## ATTACHING THE FERRITE CORE

To reduce electrical interference, attach the core filter to the AC power adaptor.

-  • To attach the core filter to power adaptor, roll the cable over core filter once.  
• Be careful not to damage the cable when attaching the core filter.

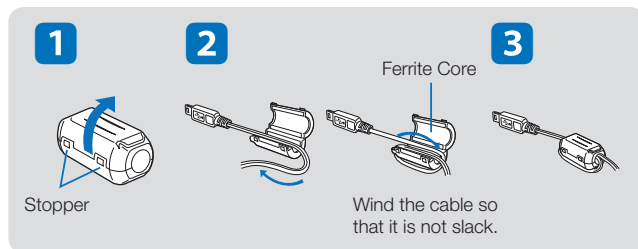

## USING THE BATTERY

Purchase extra batteries to allow continuous use of your camcorder.

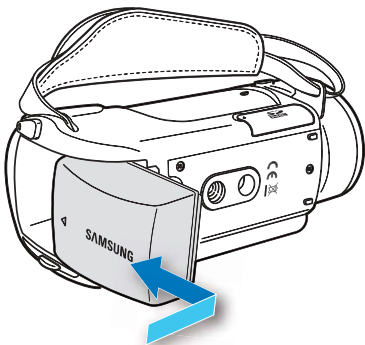

### Attaching the battery

Align the battery with the indicator (▲) on the battery compartment, and then push the battery in the direction of the arrow.

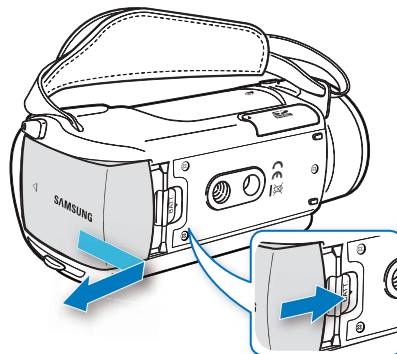

### Detaching the battery

Slide the **Battery release** switch and pull out the battery. Gently slide **Battery release** switch in the direction as shown in the figure.



- Samsung is not responsible for problems that are caused by using unapproved batteries. If you use batteries from other manufacturers, there is a danger of overheating, fire, or explosion.
- Detach the battery from the camcorder with care to prevent it from falling.

## CHARGING THE BATTERY

You can charge the battery using the AC power adaptor or the USB cable.

- Insert the battery into the camcorder. [▶ page 22](#)
- To charge, use the supplied AC power adaptor or the USB cable.

### To charge the battery

Charge the battery using the AC power adaptor or the USB cable.

- The charging (CHG) indicator lights up and charging starts. After the battery is fully charged, the charging (CHG) indicator turns green.

### Using the AC power adaptor

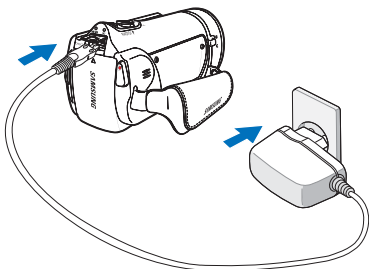

Connect the AC power adaptor to the camcorder properly, and then plug the AC Power adaptor in the wall outlet.

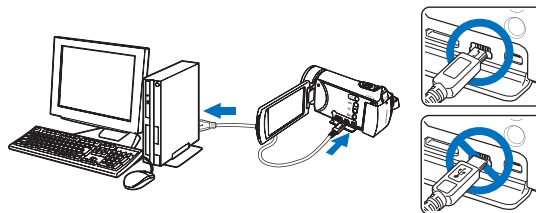

### Using the USB cable

Connect the USB cable to the camcorder properly, and then connect the other end to a USB port of a PC.



-  Please make sure that there are no foreign substances in the plug and socket when you connect the AC power supply to the camcorder.
- 
  - When charging, if both the USB cable and AC power adaptor are connected, the AC power adaptor will override the USB.
  - You cannot operate the camcorder using USB power only. Use the power adaptor or battery to power the camcorder.
  - USB charging time may depend on the type of USB host on your PC.
  - If you use the camcorder while you are charging the battery, charging may take longer.



## CHECKING THE BATTERY STATE

You can check the charging state and remaining battery capacity.

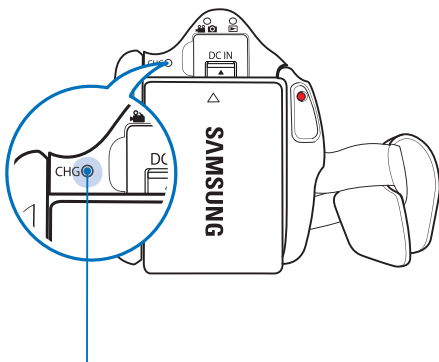
### To check the charging state







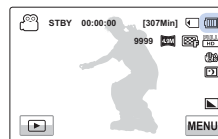

The colour of the LED indicates the power or charging state.

 (Orange)	Charging
 (Green)	Fully charged
 (Off)	Error

### Battery level display

The battery level display shows the amount of battery power remaining in the battery.



Battery Level Indicator	State	Message
	Fully charged	-
	25~50% used	-
	50~75% used	-
	75~95% used	-
	95~98% used	-
	Exhausted (flickers): The device will soon turn off. Change the battery as soon as possible.	-
-	The device will be forced to turn off after 3 seconds.	<b>"Low battery"</b>



- The figures above are based on a fully charged battery at a normal temperature. Low ambient temperature may affect the use time.
- Battery capacity decreases over time and through repeated use. Keep the camcorder turned off while not operating it.
- Store the battery separately when finished charging or when not using it for a long time. This will help extend the life of the battery.

## Available running time for the battery

Battery type	IA-BP210R	
Charging time	Using the AC power adaptor : approx. 160 min. Using the USB cable : approx. 330 min.	
Video resolution	HD	SD
Continuous recording time	Approx. 180 min.	Approx. 200 min.
Playback time	Approx. 200 min.	Approx. 260 min.

- Charging time: Approximate time in minutes required to fully charge a completely exhausted battery.
- Recording/Playback time: Approximate time available when you have fully charged the battery.  
'HD' stands for high definition image quality and 'SD' stands for standard image quality.
- Recording/Playback time may differ, depending on your usage and conditions. For example, if you use Zoom or **Recording start/stop** button repeatedly, the batteries may discharge faster.
- The recording and playback times will be shorter when you use your camcorder in low temperatures.
- We recommend using AC power adaptor when you use Art Time Lapse REC.

## Continuous Recording (without zoom)

The continuous recording time above shows the available recording time when you record without using any other function after recording starts.

The battery may discharge 2-3 times faster than this reference if you use the record start/stop, the zoom, and the play functions. Prepare additional batteries with the expectation that the actual recording time is about 1/3 to 1/2 of the times listed above.

## Using an AC power source

We recommend that you use the AC power adaptor to power the camcorder from a household AC outlet when recording and playing the camcorder indoors. The connection is the same as that for battery charging. ➔page 23

## About the battery

### • Battery Properties

A lithium-ion battery is small-sized and has a high capacity. Low ambient temperature (below 50°F (10°C)) may shorten its usage time and affect its function. Before recording in low temperatures, put the battery into your pocket to warm it, then install it in the camcorder.

### • Make sure to store the battery separately after use.

- A small amount of battery power is consumed when the battery is stored in the camcorder even if the camcorder power is off.
- The battery may be completely discharged, if it has been installed and left in the camcorder for a long period of time. If this occurs, the battery may not fully operate even if you charge it.
- If the battery is not used for a long time, fully charge the battery and then, using your camcorder, drain the charge completely once every 1 months to keep the battery functioning properly.

### • Charge an extra battery before using the camcorder outdoors in cold temperatures.

- The cold temperature may shorten the length of time you can use the battery before needing to recharge it.
- Carry the supplied AC power adaptor to charge the battery while travelling.

### • Check whether the battery terminal is damaged if the battery falls or is dropped.

- If you install a battery with the damaged terminal into the camcorder, you can damage the camcorder.

### • Remove the battery and the memory card from the camcorder and disconnect the AC power adaptor after use.

- Store the battery in a stable, cool and dry place. (Recommended temperature : 59°F ~ 77°F (15°C~ 25°C), recommended humidity: 40%~ 60%)
- Temperatures that are too high or too low shorten the battery lifetime.
- The battery terminals can become rusty or malfunction if the battery is stored in a smoky or dusty location.

### • Recycle or dispose of your dead batteries properly.

### • The battery lifetime is limited.

- Battery capacity decreases over time and through repeated use. If decreased usage time between charges becomes significant, it is probably time to replace the battery with a new one.
- Each battery's life is affected by storage, operating, and environmental conditions.



- Make sure to turn off the camcorder before disconnecting the AC power adaptor. Otherwise, you can damage the storage media or data.
- Use a nearby wall outlet when using the AC power adaptor. Disconnect the AC power adaptor from the wall outlet immediately if any malfunction occurs while using your camcorder.
- Do not place the AC Adaptor in a confined space when you use it, such as between a wall and a piece of furniture.



- Be sure to use the included AC power adaptor to power the camcorder. Using other AC power adaptors could cause electric shock or result in fire.
- You can use the AC power adaptor around the world. An AC plug adaptor is required in some foreign countries. If you need one, purchase it from your distributor.
- The charging time will vary depending on the charge remaining in the battery.
- The battery is charged over 95% after about 2 hours, and the indicator colour changes to green. It takes about 2 hours and 40 minutes for the battery to charge 100%.

# Basic operation of the camcorder

## TURNING YOUR CAMCORDER ON/OFF

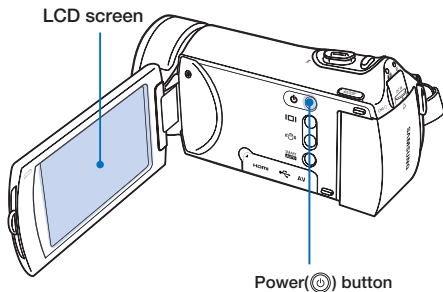

1. Open the LCD screen to turn on the camcorder.
  - Your camcorder turns on automatically when you open the LCD screen.
2. To turn off the camcorder, press the **Power** (⏻) button for about one second.



- The camcorder operates the self-diagnosis function when powered on. If a warning message appears, refer to 'warning indicators and messages' (pages 103–107) and take corrective actions.
- If you close the LCD screen when the power is on, the power saving mode activates. ➔ page 28
- The camcorder turns on automatically if connecting the AC power adaptor or inserting the battery to the camcorder with the LCD screen open.



### When using this camcorder for the first time

When you use your camcorder for the first time or reset it, the time zone screen appears at start-up. Select your geographical location, and then set the date and time. ➔ page 31  
If you do not set the date and time, the time zone screen appears every time you turn on the camcorder.

### ADJUSTING THE LCD SCREEN

The wide LCD screen on your camcorder offers high quality image viewing.

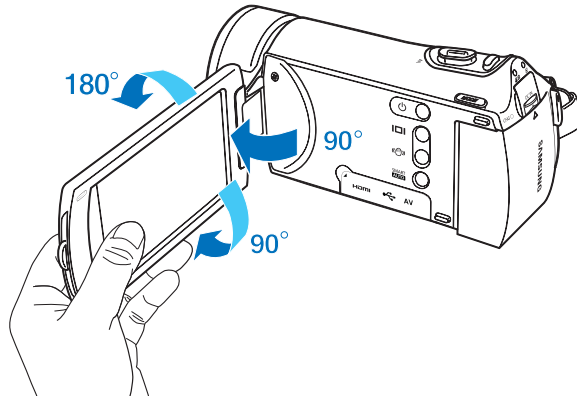

1. Open the LCD screen with your finger.
  - The screen opens up to 90°.
2. With the LCD screen open 90°, rotate it forwards (towards the lens) or backwards.
  - You can rotate it up to 180° towards the lens and up to 90° backward. To view recordings more conveniently, rotate the screen by 180° towards the lens, and then fold it back to the body.



Excessive rotation may damage the connective hinge between the screen and the camcorder.



Clean fingerprints or dust on the screen with a soft cloth.

## SETTING THE OPERATION MODES

You can switch the operating mode in the following order each time you press the **MODE** button. Record mode (📹📷) ↔ Play mode (▶️).

- Each time the operation mode changes, the respective mode indicator lights turn on.
- Touching the Play (▶️) tab in the record mode switches the operation mode to the play mode.

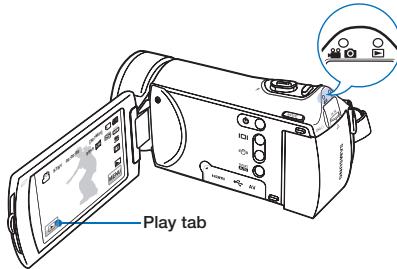

### MODE button / Mode indicators

- 📹📷 **(Record mode):**  
To record videos or photos.
- ▶️ **(Play mode):**  
To play videos or photos, or edit them.

 This camcorder provides one record mode which combines the video and photo record modes. You can easily record videos or photos in the same mode without having to change modes.

## USING THE DISPLAY (|◻|) BUTTON

Switching the information display mode

Press the Display (|◻|) button.

The full and minimum display modes alternate.

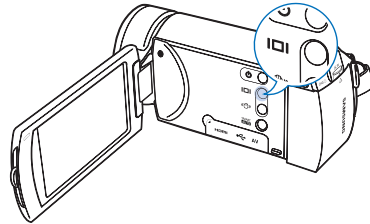

### Full display mode



### Minimum display mode

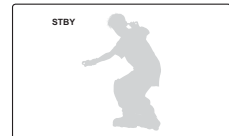

-  Warning indicators and messages may appear depending on the recording conditions.
- The **Display** (|◻|) button does not work when the menu screen is being displayed.

### USING THE TOUCH PANEL

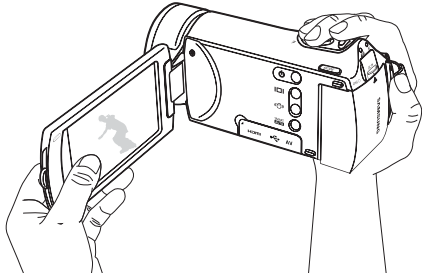



The touch panel lets you playback and record with a simple touch of your finger. Place your hand on the rear side of the LCD screen, then touch the items displayed on the screen.

#### Touch

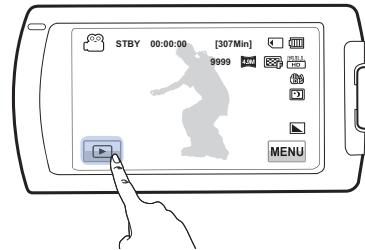
Slightly touch items with your finger to select them or to execute wv functions.



-  Do not place a protective film on the LCD screen.
-  If you leave a film attached to the LCD screen for a long time, strong adhesion between the film and the surface of the screen may cause a malfunction of the touch panel.
-  Be careful not to accidentally press the buttons near the LCD panel while using the touch panel.
- The tabs and indicators that appear on the LCD screen depend on the current recording/playback status of your camcorder.
- The camcorder does not recognise touches if you touch more than two points on the screen at the same time. Touch one point at a time.
- Do not use a sharp tipped item such as pen or pencil when using a tool to touch the screen.

# First time settings

## SETTING THE TIME ZONE AND DATE/TIME FOR THE FIRST TIME

Set the date and time of your local area when you turn on the camcorder for the first time.

1. Open the LCD screen to turn on the camcorder.
  - The time zone ("**Home**") appears based on London, Lisbon (Greenwich Mean Time).
2. Select your local area on the map by touching the left (←) or right (→) tab on the LCD screen, and then press the (OK) tab.
  - The "**Date/Time Set**" screen appears.
3. Touch the date and time information, and then change the setting values by using the up (↑) or down (↓) tabs.
4. Make sure the clock is correctly set, and then touch the (OK) tab.
  - The message "**Date/Time Set**" appears.

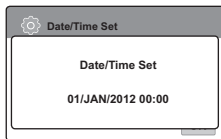
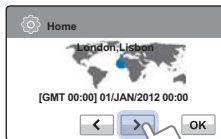

- You can set the year up to 2037, based on the "**Home**" item.
- Set "**Date/Time Display**" to On. ↪page 81
- Activating the (⚙️) icon moves the time forward by 1 hour.



### Internal rechargeable battery

- Your camcorder includes an internal rechargeable battery that retains the date and time settings even after the power is turned off.
- If the battery is depleted, the current date/time values are reset to the default values. If this occurs, you need to recharge the internal rechargeable battery (see below), and then re-set the current date and time.

### Charging the internal rechargeable battery

- The internal battery is always recharged while your camcorder is connected to the AC power or while the battery is attached.
- If you have not used the camcorder for about 2 weeks and you have not connected the AC power or the battery to it, the internal battery fully discharges. If this occurs, charge the internal battery by connecting the camcorder to the supplied AC adaptor for 24 hours.

### Turning the date and time display on/off

- To switch the date and time display on or off, access the menu and change the Date/Time Display mode. ↪page 81

### Simple setting of the clock by time difference

- You can easily set the clock to the local time by setting a time difference when using your camcorder abroad. Select "Time Zone" on the menu, then set the time difference. ↪page 79

### SELECTING THE LANGUAGES

You can select the language that displayed on the LCD screen.  
The camcorder retains the language setting even when you turn it off.

1. Touch the Menu (MENU) → Setting (⚙️) tab.
2. Touch the up (▲)/down (▼) tab until "Language" appears.

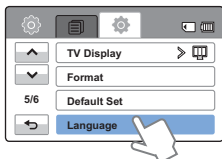

3. Touch "Language," and then touch the desired OSD language.
4. Touch the Exit (✕) or Return (↩️) tab to complete the setting.
  - The camcorder displays the menus and messages in the language you selected.



- "Language" options may be changed without a prior notice.
- The camcorder retains the language you select even when not connected to the battery or AC power.
- The date and time format may change depending on the language you selected.

# About the storage media

## SELECTING THE STORAGE MEDIA (HMX-H405 only)

You can record videos and photos in the internal memory or a memory card. Select the desired storage media before starting recording or playback.

- ✔ You can use SD or SDHC cards in your camcorder. However, some cards are not compatible depending on the memory card manufacturer and memory card type.
- Before inserting or ejecting the memory card, turn the camcorder off.

1. Touch the Menu (MENU) → Setting (⚙️) tab.
2. Touch the up (⬆️)/down (⬇️) tab until “Storage Type” appears.
3. Touch “Storage Type,” then touch the desired storage media.

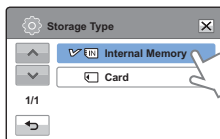
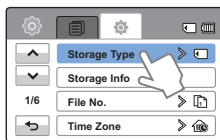

### Submenu items

- **Internal Memory** (📄): When using the internal memory.
- **Card** (📄): When using the memory card (SD or SDHC card).



- Do not format the internal memory or any memory card you intend to use in the camcorder on a PC.
- When you insert a memory card, the storage media setup screen appears. Touch “Yes” if you want to use a memory card, or “No” if not.
- Do not remove the power (battery or AC power adaptor) when accessing storage media to record, playback, format, delete, etc. The storage media and its data may be damaged.
- Do not eject a memory card while it is being used in the camcorder. The memory card and its data may be damaged.

## INSERTING / EJECTING A MEMORY CARD (NOT SUPPLIED)

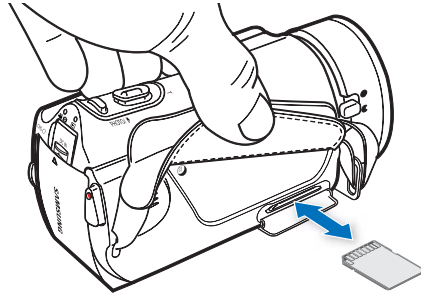
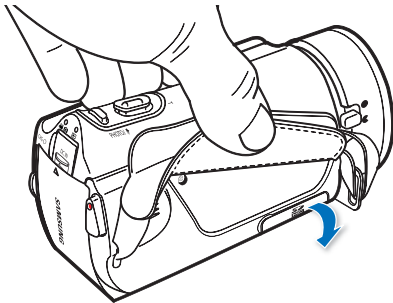

### To insert a memory card

1. Turn the camcorder off.
2. Open the memory card cover.
3. Insert the memory card into the card slot until it softly clicks.
  - Make sure that the camcorder is placed as shown above and the terminal portion of the card is facing up.
4. Close the memory card cover.

### To eject a memory card

1. Turn the camcorder off.
2. Open the memory card cover.
3. Gently push the memory card to eject it.
4. Close the memory card cover.

-  • To avoid data loss, turn off the camcorder by pressing the **Power** (⏻) button for one second before inserting or ejecting the memory card.
- Be careful not to push the memory card too hard. The memory card may suddenly pop out.

-  Your camcorder supports only SD (Secure Digital) and SDHC (Secure Digital High Capacity) cards. Card compatibility may vary depending on the manufacturer and the type of memory card.

### SELECTING A SUITABLE MEMORY CARD (NOT SUPPLIED)

#### Compatible memory cards

- You can use SD (Secure Digital) and SDHC (Secure Digital High Capacity) cards with this camcorder.  
We recommend you use an SDHC (Secure Digital High Capacity) card.  
This camcorder supports SD cards up to 2GB. We cannot guarantee normal operation with SD cards bigger than 2GB.
- MMC (Multi Media Card) and MMC Plus are not supported.
- Compatible memory card capacity:  
SD: 1GB ~ 2GB  
SDHC: 4GB ~ 32GB
- For video recording, use a memory card that supports faster write speeds (above SDHC Class 6 card).
- SD/SDHC memory cards have a mechanical write-protection switch. Setting the switch prevents accidental erasure of files recorded on the card. To enable writing, move the switch up in the direction of the terminals. To set write protection, move the switch down.

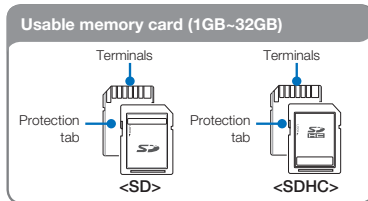

#### SDHC (Secure Digital High Capacity) cards

- An SDHC card is a higher version (Ver. 2.00) of the SD card and supports capacities above 2GB.
- SDHC cards cannot be used with current SD enabled host devices.

#### Common cautions for memory cards

- Damaged data may not be recoverable. We recommend you make a back-up of important data separately on the hard disk of your PC.
- Turning the power off or removing a memory card during an operation such as formatting, deleting, recording, and playback may cause data loss.
- If you modify the name of a file or folder stored in the memory card with your PC, your camcorder may not recognise the modified file.

### Handling a memory card

- We recommend that you power off before inserting or removing the memory card to avoid data loss.
- We cannot guarantee that you can use memory cards formatted by other devices. When you format a card, be sure to format the memory card using this camcorder.
- You must format newly-purchased memory cards, memory cards with data that your camcorder cannot recognise, and cards with data saved by other devices. Note that formatting erases all data on the memory card. If you cannot use a memory card that has been used with another device, format it with your camcorder. Note that formatting erases all information on the memory card.
- A memory card has a certain life span. If you cannot record new data, you have to purchase a new memory card.
- Do not bend, drop, or subject the card to strong impacts.
- Do not place foreign substances on the memory card terminals. Use a soft dry cloth to clean the terminals if required.
- Do not paste anything other than the label provided with the card on the label pasting area of the card.
- Do not use a damaged memory card.
- Be careful to keep the memory card out of the reach of children, who might swallow it.

### The camcorder supports SD and SDHC memory cards, giving you a wider choice of cards to choose from!

The data storage speed may differ, depending on the manufacturer and production system.

- SLC (Single Level Cell) system: faster write speed enabled.
- MLC (Multi Level Cell) system: only lower write speed is supported.

For best results, we recommend using a memory card that supports a faster write speed.

Using a lower write speed memory card for recording video may cause difficulties when storing.

You may even lose your video data during the recording.

In an attempt to preserve every bit of the recorded video, the camcorder forcibly stores the video on the memory card and displays a warning:

**“Low speed card. Please record at a lower resolution.”**

If you are unavoidably using a low speed memory card, the resolution and quality of the recording may be lower than the value you set. ➔page 53

The higher the video resolution and quality, the more memory the camcorder uses.



- Samsung is not responsible for data loss due to misuse, including loss caused by any PC virus.
- We recommend using a memory card case to avoid data loss that can be caused by moving the card or by static electricity.
- After a period of use, the memory card may get warm. This is normal and is not a malfunction.

### RECORDABLE TIME AND CAPACITY

Listed below are the available video recording times and the number of photos the camcorder can take, by card memory size and resolution. Refer to the recordable video time and the number of photos when recording videos or taking photos.

#### Recording time available for video in minutes

Resolution	Quality	Internal memory*	Storage media (Capacity)					
			32GB	1GB	2GB	4GB	8GB	16GB
1080/50i	Super Fine	247	8	15	30	61	125	253
	Fine	300	9	18	36	74	152	307
	Normal	381	12	23	46	94	193	390
720/50p	Super Fine	350	11	21	42	86	177	357
	Fine	465	14	28	57	115	235	475
	Normal	692	21	42	84	171	351	708
576/50p	Super Fine	1028	32	63	126	254	521	1051
	Fine	1357	42	83	166	336	688	1387
	Normal	1995	62	123	244	494	1011	2039

(Unit: Approximate minutes of recording)

#### Recordable number of photos

Resolution	Internal memory*	Storage media (Capacity)					
		32GB	1GB	2GB	4GB	8GB	16GB
2944x1656	9999	656	1251	2482	5014	9999	9999
1920x1080	9999	1173	2346	4654	9402	9999	9999

(Unit: Approximate number of images)

**1GB ≙ 1,000,000,000 bytes : Actual formatted capacity may be less as the internal firmware uses a portion of the memory.**



- Actual recording times may differ depending on the recording conditions and the subject.
- The higher the quality and resolution, the more memory is used.
- Lower resolution and quality increases the recording time, but the image quality may suffer.
- The bit rate automatically adjusts to the recording image. Accordingly, the recording time may vary.
- Memory cards bigger than 32GB may not operate normally.
- When a video file exceeds 1.8GB, a new video file is created automatically.
- The maximum number of recordable photo and video files is 9999 respectively.
- The recording length of Art Time Lapse may vary depending on settings.
- Items marked with \* are available only with HMX-H405 models.

# Basic recording

## RECORDING VIDEOS

This camcorder supports both High Definition (HD) and Standard Definition (SD) image resolutions. Set the resolution you want before recording. →page 53

- ✓ Insert a memory card. →page 34
- Set the appropriate storage media. (HMX-H405 only) →page 33
- Open the LCD screen to turn on the camcorder. Your camcorder turns on automatically when you open the LCD screen.
- Set the Lens open/close switch to open (☑). →page 16
- Select the record mode by pressing the **MODE** button. →page 29

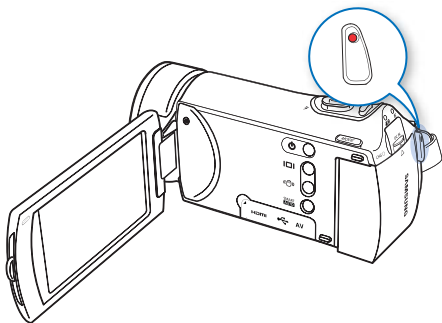

- Select a subject to record.
  - Adjust the LCD panel to the best angle for recording.
  - Use the **Zoom** lever to adjust the size of the subject. →page 43
- Press the **Recording start/stop** button.
  - The recording (●) indicator appears, and recording starts.
- To stop recording, press the **Recording start/stop** button again.
- Touch the Quick View (▶) icon to view the most recently recorded video.
  - After the Quick View is complete, your camcorder returns to the standby mode.

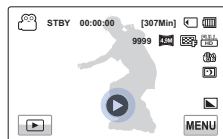
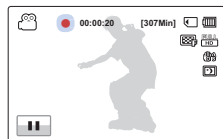

### Using the continuous recording function

Using the Continuous Recording function, you can avoid recording unwanted scenes while recording video. Using this function, you can make one video file while you record only desired scenes.

- Press the **Recording start/stop** button.
  - The recording (●) indicator appears, and recording starts.
- Touch the Pause tab, then it will pause the recording with appearing (||) indicator.
  - If you want to record continuously touch the Rec tab again, and if you want to stop the recording touch the Stop tab.





- If power is interrupted or an error occurs during recording, the video may not be recorded/edited.
- Samsung is not responsible for any damage caused by a failure of normal recording or playback operations because of a memory card error.
- Note that damaged data cannot be recovered.
- Do not turn off the camcorder or remove the memory card while the camcorder is accessing the memory card. Doing so may damage the memory card or the data in the memory card.



- Videos are compressed in the H.264 (MPEG-4.AVC) format.
- Eject the battery when you have finished recording to prevent unnecessary battery power consumption.
- For the on-screen information display, see pages 103~107
- For approximate recording time, see page 37.
- Sound is recorded by the internal stereo microphone located on the front of the camcorder.  
Make sure that the microphone is not blocked.
- Before recording an important video, make sure to test the recording function to see if there are any problems with the audio or video recording.
- For various functions available during recording, see pages 53~70
- If the power cable/battery is disconnected or recording is interrupted, the camcorder switches to the data recovery mode. While data is being recovered, no other function is enabled.
- In the record mode, you can set the Quick View menu option. The Quick View icon appears when you have set the Quick View menu option to On.
- The menu setting tabs shown on the LCD screen do not affect the image the camcorder is recording.
- Under some low light conditions that may be encountered, the video motion may not be fluid as under normal light conditions.
- The noise from around area may be recorded if you record video in a quiet environmental place because of increased microphone sensitivity. Due to increased microphone sensitivity, the noise occurred by motor when the zoom is moving can be recorded.
- ISO will be automatically adjusted when recording indoor or in a dark place. At this time, the video may occur noise or if you record the video in a very dark place, you may not able to check it. When recording at night, we recommend you to use professional camcorders which have an infrared imaging system.
- When executing HDIS on a tripod or on a fixing device, the image may be shaken. when fixing the camcorder on a tripod, set HDIS off.
- Even using the Continuous Recording function, it can record videos maximum 1.8GB. After resuming to recording videos from pause, if the recorded file exceeds 1.8GB, it will be automatically recorded to the next file.
- When the camcorder powers off when recording, the video will be saved in the storage media.

## TAGGING GREAT MOMENTS WHILE RECORDING (MY CLIP FUNCTION)

Using the My Clip function, you can tag good scenes while recording and enjoy the scenes tagged as My Clip (📌) from a long video.

- ✔ Insert a memory card. ↪ page 34
- ✔ Set the appropriate storage media. (HMX-H405 only) ↪ page 33
- ✔ Open the LCD screen to turn on the camcorder. Your camcorder turns on automatically when you open the LCD screen.
- ✔ Set the Lens open/close switch to open (🔆). ↪ page 16
- ✔ Select the record mode by pressing the **MODE** button. ↪ page 29

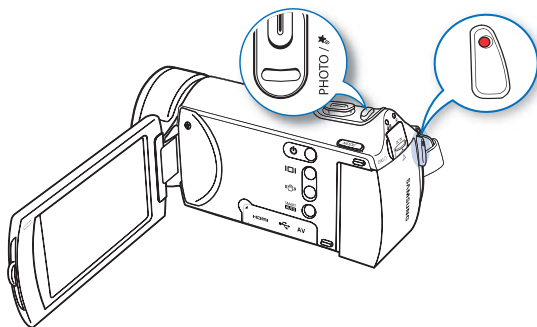

1. Press the **Recording start/stop** button.
  - The recording (●) indicator appears, and recording starts.
2. Press the **PHOTO / 📌 (My Clip)** button every great moment while recording.
  - The camcorder tags the scene as My Clip (📌).
3. To stop recording, press the **Recording start/stop** button again.

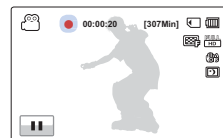

### Understanding the My Clip function

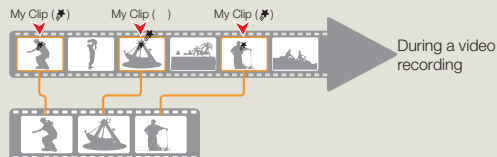





When the camcorder extracts the scenes tagged as My Clip (📌) and creates one file with them, the file is saved in the video thumbnail view.

- ✔ The camcorder tags the scene so that it starts 3 seconds before you pressed the **PHOTO / 📌 (My Clip)** button and ends 5 seconds after.
- ✔ You can also tag any scenes in a video by pressing the **PHOTO / 📌 (My Clip)** button during a video playback.
- ✔ To skip boring parts of a video and enjoy exciting parts, you can combine the tagged scenes sequentially. ↪ page 72
- ✔ The camcorder can tag up to 999 scenes from a video as My Clip (📌) scenes.

## RECORDING PHOTOS

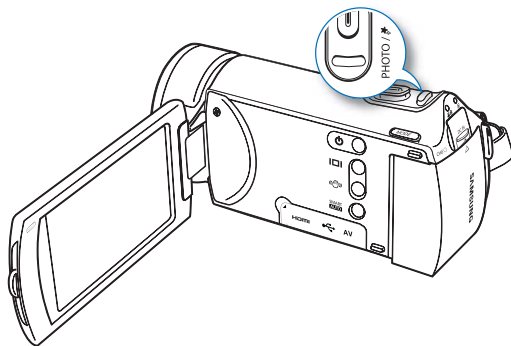

You can take photos and store them in the storage media. Set the desired resolution before recording. [↖page 54](#)

-  • Insert a memory card. [↖page 34](#)
-  • Set the appropriate storage media. (HMX-H405 only) [↖page 33](#)
-  • Open the LCD screen to turn on the camcorder. Your camcorder turns on automatically when you open the LCD screen.
-  • Set the Lens open/close switch to open (☺). [↖page 16](#)
-  • Select the record mode by pressing the **MODE** button. [↖page 29](#)



1. Select a subject to record.
  - Adjust the LCD panel to the best angle for recording.
  - Use the **Zoom** lever to adjust the size of the subject. [↖page 43](#)
2. Frame the subject in the LCD screen, and then half-press the **PHOTO / My Clip** button.
  - When the subject is in focus, (●) indicator appears green. If it appears red, readjust the focus.
3. Fully press the **PHOTO / My Clip** button.
  - The shutter sound is heard. (when "Shutter Sound:On" is set)
4. Touch the Quick View (▶) icon to view the most recently recorded photo.
  - To return to the standby mode, touch the Return (⏪) tab.











-  Do not turn off the camcorder or remove the memory card when taking photos as it may damage the storage media or data.
- 
  - The recordable number of photos varies depending on the recording conditions and the photo resolution. [↖page 37](#)
  - The camcorder does not record audio when you take photos.
  - Do not turn off the camcorder or remove the memory card when taking photos as it may damage the storage media or data.
  - If focusing is difficult, use the manual focus function. [↖page 59](#)
  - For the on-screen display information, see pages 103~107.
  - For various functions available during recording, see pages 53~70.
  - Photo files conform to the DCF (Design rule for Camera File system) standard, established by JEITA (Japan Electronics and Information Technology Industries Association).

## RECORDING WITH EASE FOR BEGINNERS (SMART AUTO)

In Smart Auto mode, your camcorder automatically chooses the appropriate settings based on the type of scene it detects (Indoor, Night, etc.). Smart Auto mode is helpful if you are not familiar with the best camcorder settings for various scenes.

1. Press the **SMART AUTO** button.
2. Align your subject in the frame.
  - The camcorder automatically detects the scene when you align the subject.
  - The appropriate scene icon appears on the LCD screen.

	Appears when recording at night. (Night)
	Appears when recording images of landscapes with backlighting. (Backlight)
	Appears when recording people. (Portrait)
	Appears when recording a very bright scene. (White)
	Appears when recording an outdoor scene. (Landscape)
	Appears when recording images of close-up. (Macro)
	Appears when recording images of clear skies. (Blue sky)
	Appears when recording images of forested areas. (Natural green)
	Appears when recording images of sunsets. (Sunset)

3. Press the **Recording start/stop** button or **PHOTO / ** (**My Clip**) button.  pages 38, 41
4. To cancel Smart Auto mode, press the **SMART AUTO** button again.

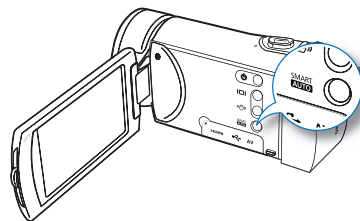

<When recording a close-up>



- **Buttons unavailable during Smart Auto operation:** Menu () tab / Anti-shake (OIS) button/ etc.

Most settings are automatically adjusted in Smart Auto mode. To set or adjust functions on your own, release the Smart Auto mode first.

- SMART AUTO must be set before recording.
- When there is no detected scene, the  icon appears.
- The camcorder may not select the correct scene depending on shooting conditions, such as camcorder shake, lighting, and distance to the subject.

## ZOOMING

This camcorder allows you to record using optical 30x power zoom and digital zoom by sliding the **Zoom** lever.

### To zoom in

Slide the zoom lever towards **T** (telephoto).

- The distant subject is gradually magnified.
- The highest zoom magnification ratio is 30x in the normal zoom-in.

### To zoom out

Slide the zoom lever towards **W** (wide angle).

- The subject gets smaller and further away.
- The smallest optical zoom ratio is the subject's original size when zoomed-out.

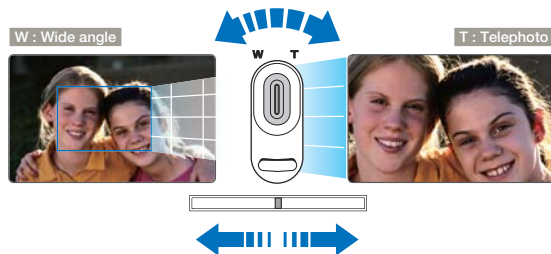

### Zoom speed

When using the zoom function, you can decrease zoom speed by slowly moving the Zoom (W/T) lever. Moving it faster increases the zoom speed.



- Using the optical zoom does not degrade the image quality and clarity.
- Use the digital zoom when you want to zoom more than the optical zoom range. ➔page 63
- Focusing may become unstable when you record with a fast zoom or zoom into a subject standing too far away. If this occurs, use the manual focus function. ➔page 59
- The minimum distance you can have between the camcorder and subject while maintaining sharp focus is about 1cm (about 0.4 inches) for wide angle and about 100cm (about 39.4 inches) for telephoto. (about 50cm (19.7 inches) for Tele Macro.)
- If you want to shoot the subject close to the lens at a wide angle, use the Tele Macro function. ➔page 62
- Frequent use of the zoom function consumes more power.
- The camcorder can record the sound of the zoom mechanism.
- When using the zoom function while holding the camcorder with your hand, use Anti-shake (OIS) for stable recording. ➔page 44

## Anti-Shake (OIS: Optical Image Stabiliser)



Use the Anti-shake (OIS: Optical Image Stabiliser) function to compensate for unstable images caused by shaking movements when holding the camcorder.

 Select the record mode by pressing the **MODE** button. →page 29

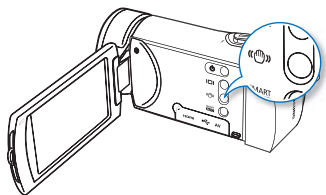
Each press the **Anti-shake (OIS)** () button repeat the Anti-shake (OIS), Anti-shake (OIS DUO), Anti-shake (OIS DUO+) and Off.



### Submenu items

- **Off:** Disables the function.
- **OIS** (): The Anti-Shake(OIS) function is enabled to compensate for shaking.
- **OIS DUO** (): By applying both optical and digital image stabilization, it produces recordings with minimised hand-shaking.
- **OIS DUO+** (): This is advanced function for OIS DUO's performance. It allows the camcorder to compensate for greater degrees of camcorder shake and delivers a stunning level of image smoothness.



Use the Anti-Shake(OIS) function in the following cases

- When recording while walking or riding in a moving car.
- When recording with the zoom function.
- When recording subjects of a small size.



### Understanding OIS DUO



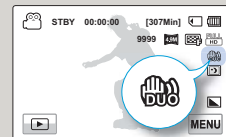

- Reduce camcorder shake and prevent blurred images with Optical and Digital Image Stabilization functions.



- When you turn on Smart Auto mode, it automatically sets Anti-shake (OIS) to On.
- The Anti-Shake (OIS) function may not correct gross camcorder shake entirely. To decrease shake, hold the camcorder firmly with both hands.
- When this function is On, the actual movement of the subject and the movement displayed on the screen may be slightly different.
- When you record in dark or dim light at high magnification while this function is On, after-images may stand out. If this occurs, we recommend using a tripod (not supplied) and turning Anti-shake (OIS) to Off.

# Basic playback

## CHANGING THE PLAYBACK MODE

- You can set the record mode and the play mode in turn with the **MODE** button.  
You can also switch the operation mode directly into the playback thumbnail display by touching the Play () tab on the LCD screen.
- The most recently created file is highlighted in the thumbnail view.
- The camcorder selects the thumbnail display options based on the standby mode that was last used. However, you can choose the video (HD or SD) or photo thumbnail view display options by touching the HD () , SD () , or photo () tab on the LCD screen.





### Understanding how to change the operation modes

You can easily change the operation modes by touching the LCD screen or using the buttons as shown in the following figures:



### To change thumbnail display type

You can choose from these thumbnail display options: 3x2 () , 4x3 () , and Date () .



<3X2 type>



<4X3 type>



<Sorted by date>

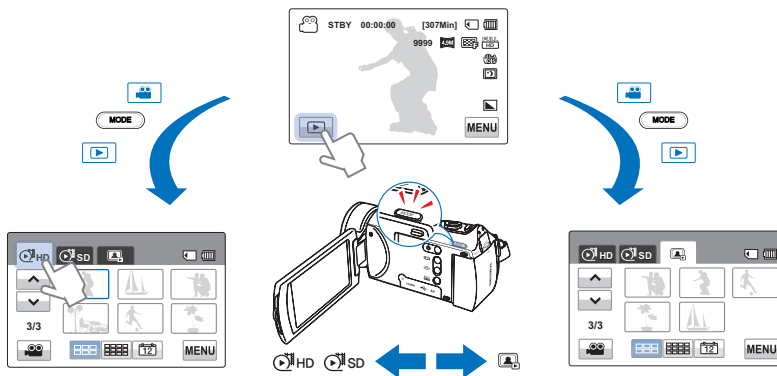

## PLAYING VIDEOS

You can preview recorded videos in the thumbnail index view, find the video you want quickly, and playback directly.

- ✓ Insert a memory card. ↪ page 34
- Set the appropriate storage media. (HMX-H405 only)  
↪ page 33
- Touch the Play (▶) tab on the LCD screen to select the play mode.  
↪ page 45

1. Touch the HD (HD) or SD (SD) tab.

- Video thumbnails corresponding to the video resolution you selected appear on the screen.
- To change the current thumbnail page, touch the up (▲) or down (▼) tab.

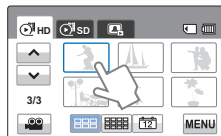

2. Touch the thumbnail of the desired video clip.

- The camcorder plays the video you selected and playback control tabs appear briefly. They reappear when you touch anywhere on the screen.
- To stop playback and return to the thumbnails, touch the Return (◀) tab.



- ⚠ Do not power off the camcorder or eject the memory card during video playback. Doing so may damage the recorded data.

- ✎ It may take some time to start playback, depending on the size and quality of the selected video.
- The camcorder may not play the following video files:
  - A video recorded on another device.
  - A video whose file format is not supported by the camcorder.
- You can use various play options during the video playback.
- You can set playback settings using the "Play Option" menu.  
↪ page 68
- You can play the recorded videos on a TV or PC. ↪ pages 90, 96
- If you touch the Menu (MENU) tab during playback, play is paused and the menu screen appears.

## Playback / Pause / Stop

- Playback and pause alternate when you touch the Pause (⏸) / Play (▶) tab during playback.
- Touch the Return (↶) tab to stop playback.

## Search playback

During playback, each touch of the Reverse search (⏮) / Forward search (⏭) tab increases the play speed:

- RPS (Reverse Playback Search)/ FPS (Forward Playback Search) rate: x2 → x4 → x8 → x2

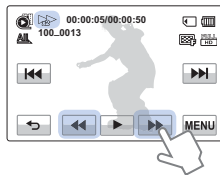

## Skip playback

Touch the Reverse skip (⏮) / Forward skip (⏭) tab during playback.

- Touching the Forward skip (⏭) tab plays the next video.
- Touching the Reverse skip (⏮) plays the beginning of the scene. If you touch the Reverse skip (⏮) for three seconds or less after a video starts, the camcorder plays the previous video.
- Place and hold your finger on the Reverse skip (⏮) / Forward skip (⏭) tab to search for a video number quickly. When you lift off your finger, the camcorder plays the video you selected.

## Slow playback

When playback is paused, touching the Reverse slow (◀) / Forward slow (▶) tab reduces the playback speed:

- Reverse/forward playback slow rate: x1/2 → x1/4 → x1/8 → x1/2



## Frame by frame playback

When playback is paused, touch the Reverse frame advance (⏮) / Forward frame advance (⏭) to make the video go in reverse or forward one frame at a time.

## To adjust the volume

You can hear the recorded sound from the internal speaker.

1. Touch the Volume (🔊) tab on the LCD screen.
2. Touch the (−)/(+) tab to increase or decrease audio volume.
  - You can adjust the sound level between “0–19.” When the level is at “0,” you cannot hear sound.

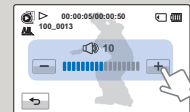

- Touch the Play (▶) tab to play back in normal speed.
- You can hear the recorded sound only when you playback at normal speed.

## VIEWING PHOTOS

You can view recorded photos using various playback functions.

- ✔ Insert a memory card. ↪ page 34
- ✔ Set the appropriate storage media. (HMX-H405 only)  
↪ page 33
- ✔ Touch the Play (▶) tab on the LCD screen to select the play mode.  
↪ page 45

1. Touch the Photo (🖼️) tab.
  - The thumbnail view appears.
  - To change the current thumbnail page, touch the up (⬆️) or down (⬇️) tab.
2. Touch the photo you want to display.
  - The camcorder displays the photo you selected in full screen and playback control tabs appear briefly. They reappear when you touch anywhere on the screen.
3. To return to the thumbnails, touch the Return (⏪) tab.

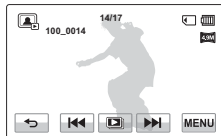
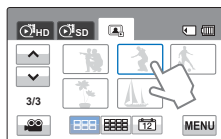
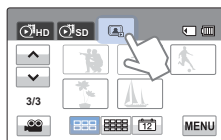



⚠ Do not power off the camcorder or eject the memory card during photo playback. Doing so may damage the recorded data.

- ✍ Loading time may vary depending on the size and quality of the photo you selected.
- Your camcorder may not play back the following photo files normally:
  - A photo recorded on another device.
  - A photo with a file format not supported by this camcorder. (One that does not conform to DCF standards.)
- Touch previous image (⏪) / next image (⏩) tab to view the previous and next photo.

## Viewing a slide show

You can view a photo slide show with background music.

Touch the Slide Show (  ) tab during photo playback.

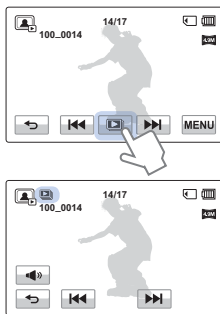

- The  indicator appears. The slide show starts from the current selected photo.
- To stop the slide show, touch the Return (  ) tab.



### To start a slide show in the menu screen

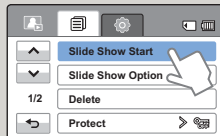



Touch the Menu (  ) tab → "Slide Show Start."



- All photos are played back depending on the slide show options.   
↳ page 70
- If you select the thumbnail display by date (  ), the camcorder plays back only photos taken on the corresponding date in the slide show.
- You can adjust the background music's volume level using the Volume (  ) tab while playing back the slide show with music.

## Zooming during photo playback

You can magnify a playback image. Touch up/down/left/right to select the area to magnify.

1. Touch the photo you want to magnify.
  - The camcorder displays the selected photo on the full screen.
2. Adjust the magnification with the **Zoom (W/T)** lever.
  - Magnification starts from the centre of the photo.
  - You can zoom in from x1.1 to x8.0.
3. Touch the up (  )/down (  )/left (  )/right (  ) tab to view the area you want on the magnified photo.
4. To cancel, touch the Return (  ) tab.

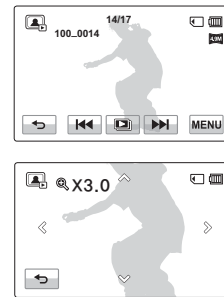

- Photos recorded on other devices or those edited on a PC cannot be magnified.
- While the playback zoom is in use, other images cannot be selected.

# Using the menu items

## HANDLING MENUS

The instructions below are examples of how to access and use menu items using the Menu (MENU) tab. When you access and use other menu items, use these examples as guides.



Menu tab

- ✓ Insert a memory card. ↪page 34
- ✓ Set the appropriate storage media. (HMX-H405 only)  
↪page 33
- ✓ Select the record mode by pressing the **MODE** button. ↪page 29

1. Touch the Menu (MENU) tab on the touch panel.

- The menu screen appears.
- To change the current page, touch the up (▲) / down (▼) tab.



2. Touch "iSCENE." (The iSCENE function is used here as an example.)

3. Touch the desired option.
  - Adjust the setting values accordingly.
4. To exit the menu, touch the Exit (X) or Return (↶) tab.

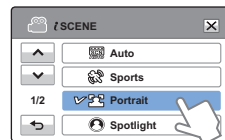

- ✎ When using Menu items, some menu items cannot be used at the same time, or may be greyed out. For more information, see Troubleshooting on page 113.
- For easy understanding, the menu setting procedures on this page are explained using the simplest methods. Menu setting methods can differ depending on the menu options you choose.

## MENU ITEMS

- The items available in each menu vary depending on the operating mode.
- For item operation details, see the page number listed under Page in the table.

### Recording menu items

Items	Default value	Page
 SCENE	Auto	53
Video Resolution	1080/50i	53
Video Quality	Fine	54
Photo Resolution	2944x1656	54
Photo Sharpness	Normal	55
White Balance	Auto	55
Aperture	Auto	56
Shutter	Auto	57
EV	0	58
Super C.Nite	Normal	58
Focus	Auto	59
Anti-Shake(OIS)	OIS	44
Digital Effect	Off	60
Fader	Off	61
Tele Macro	Off	62
Cont. Shot	Off	62
Wind Cut	Off	63
Digital Zoom	Off	63
Self Timer	Off	64
Art Time Lapse REC	Off	64
Quick View	On	67
Guideline	Off	68

## Playback menu items

Operation mode Items		Video		Photo		Default value	Page
		Thumbnail	Single	Thumbnail	Single		
Play Option		●	●	X	X	Play All	68
Highlight		●	●	X	X	-	69
Delete		●	●	●	●	-	71
Delete My Clip		●	●	X	X	-	72
Protect		●	●	●	●	Off	73
Copy*		●	●	●	●	-	74
Edit	Divide	●	●	X	X	-	75
	Combine	●	X	X	X	-	76
File Info		●	●	●	●	-	70
Slide Show Start		X	X	●	●	-	49
Slide Show Option		X	X	●	●	-	70

● : available, X : not available



- Menu options and default values may be changed without prior notice.
- Some grey coloured menu options cannot be selected. ↪page 113
- Items marked with \* are available only with HMX-H405 model.



# Advanced recording

## iSCENE

Using the iScene function, you can select a setting that matches the scene you are shooting (Sports, Portrait, etc.). Based on your selection, the camcorder sets the appropriate shutter speed and aperture automatically for optimal recording.

 Select the record mode by pressing the **MODE** button. [↪ page 29](#)





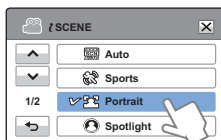



1. Touch the Menu () tab →  
“iSCENE.”

2. Touch the desired submenu item.  
• To change the current page, touch the up () / down () tab.



3. To exit the menu, touch the Exit () or Return () tab.

### Submenu items



- **Auto** (): For recording under normal conditions.
- **Sports** (): For recording people or objects in motion.
- **Portrait** (): For recording portraits. Captures natural skin tones.
- **Spotlight** (): When strong light strikes the subject. On stage, for example.
- **Beach/Snow** (): Where the reflection of light is intense such as a snowfield or beach.
- **Food** (): To make food more colourful.
- **Candle Light** (): For recording in the soft glow of candlelight.
- **Indoor** (): For recording indoors with artificial light.

 When you specify “Aperture: Manual” or “Shutter: Manual,” the iSCENE mode is cancelled.

## Video Resolution



You can select the resolution of the video to be recorded.

 Select the record mode by pressing the **MODE** button. [↪ page 29](#)

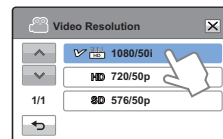
1. Touch the Menu () tab →  
“Video Resolution.”
2. Touch the desired submenu item.
3. To exit the menu, touch the Exit () or Return () tab.



### Submenu items

- **1080/50i** (): Records in the HD (1920x1080/50i) format.
- **720/50p** (): Records in the HD (1280x720/50p) format.
- **576/50p** (): Records in the SD (720x576/50p) format.

-  • “50i” indicates the camcorder will record in interlaced scan mode at 50 fields per second.
- “50p” indicates the camcorder will record in progressive scan mode at 50 frames per second.
- Recorded files are encoded using Variable Bit Rate (VBR). VBR is an encoding system that automatically adjusts the bit rate in response to the image being recorded.
- The available video recording time differs according to the video resolution you select. [↪ page 37](#)

## Video Quality

You can select the quality of the video to be recorded.

- ✓ Select the record mode by pressing the **MODE** button. ↪ page 29

1. Touch the Menu (MENU) tab → "Video Quality."
2. Touch the desired submenu item.
3. To exit the menu, touch the Exit (X) or Return (↩) tab.

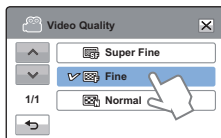

### Submenu items

- **Super Fine** (📷): Records videos in super fine image quality.
- **Fine** (📷): Records videos in fine image quality.
- **Normal** (📷): Records videos in normal image quality.

- ✍ The higher the resolution is, the shorter the available recording time. On the other hand, the lower the resolution, the longer the available recording time.

## Photo Resolution

You can select the resolution of the photo to be recorded.

- ✓ Select the record mode by pressing the **MODE** button. ↪ page 29

1. Touch the Menu (MENU) tab → "Photo Resolution."
2. Touch the desired submenu item.
3. To exit the menu, touch the Exit (X) or Return (↩) tab.

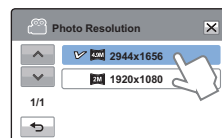

### Submenu items



- **2944x1656** (📷): Records in the 2944x1656 resolution.
- **1920x1080** (📷): Records in the 1920x1080 resolution.

- ✍ The number of recordable images differs according to the photo resolution you select. ↪ page 37
- Photos that are recorded on your camcorder may not playback properly on other digital devices that do not support these photo sizes.

## Photo Sharpness



This function lets you create more sharper or softer image by processing the captured image when you take a photo.

 Select the record mode by pressing the **MODE** button. →page 29

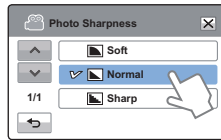
1. Touch the Menu (  ) tab → "Photo Sharpness."
2. Touch the desired submenu item.
3. To exit the menu, touch the Exit (  ) or Return (  ) tab.





### Submenu items

- **Soft** (  ): Smooths the edges of photo images. Makes image softer.
- **Normal** (  ): The photo images appear with sharp edges and are suitable for printing.
- **Sharp** (  ): Sharpens the edges in photo images further.

## White Balance



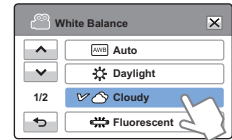

This camcorder automatically adjusts the colour of the subject. You can record in natural colours depending on the subject and lighting conditions.

 Select the record mode by pressing the **MODE** button. →page 29

1. Touch the Menu (  ) tab → "White Balance."
2. Touch the desired submenu item.
3. To exit the menu, touch the Exit (  ) or Return (  ) tab.



### Submenu items

- **Auto**: Controls the white balance automatically in response to lighting conditions.
- **Daylight** (  ): For recording outdoors in clear, natural light.
- **Cloudy** (  ): For recording in the shade or cloudy weather.
- **Fluorescent** (  ): For recording under white fluorescent lights.
- **Tungsten** (  ): For recording under halogen lamps and incandescent lights.
- **Custom WB** (  ): Lets you adjust the white balance manually to match the light source or situation.



### Understanding White Balance

The White Balance (WB) process removes unrealistic colour casts, so that white objects are rendered white in your image and all other colours look natural. Proper white balance has to take into account the "colour temperature" of a light source, which refers to the relative warmth or coolness of white light.

## To set the white balance manually

1. Touch the Menu (MENU) tab → "White Balance" → "Custom WB."
  - The "(WB) Set White Balance" indicator appears.
2. Fill the screen with a white subject, and then touch the (OK) tab.
  - The camcorder stores the white balance setting.
3. To exit the menu, touch the Exit (X) or Return (↩) tab.
  - The camcorder applies the stored white balance the next time you record.

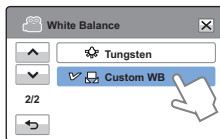

- When setting the white balance manually, the subject must be white, otherwise, your camcorder may not detect an appropriate setting value.
- The adjusted setting remains until you set the white balance again.
- During normal outdoor recording, setting White Balance to "Auto" may provide better results.
- Cancel the digital zoom function for clear and precise white balance setting. → page 63
- Reset the white balance if light conditions change.

## Aperture

The camcorder adjusts the aperture (lens opening) automatically depending on the subject and recording conditions. You can also manually adjust the aperture.

- ✓ Select the record mode by pressing the **MODE** button. → page 29

1. Touch the Menu (MENU) tab → "Aperture."
2. Touch the desired submenu item.
3. To exit the menu, touch the Exit (X) or Return (↩) tab.

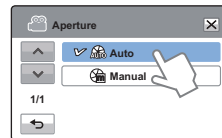

### Submenu items

- **Auto:** Sets the aperture value automatically.
- **Manual (M):** Touch the decrease (←) or increase (→) tab to adjust the aperture. You can choose from the following settings:  
F1.8, F2, F2.8, F4, F5.6, F8, F11, F16

### Understanding Aperture

You can adjust the aperture value to control the amount of light reaching the image sensor. The smaller the aperture value, the greater the amount of light. For example, F1.8 lets in more light than F2.8. You need to adjust the aperture value in the following cases:

- When you are shooting against the light or when the background is too bright.
- When you are shooting on a reflective natural background such as at the beach or when skiing.
- When the background is overly dark (for example, scenery at night).





- When you specify "**Aperture: Manual**," the **SCENE** mode is cancelled, "**Super C.Nite**" is set to "**Off**," and "**Shutter**" is set to "**Auto**" automatically.
- If the aperture is set to manual, the aperture value changes depending on the zoom level you change.

## Shutter



The camcorder automatically sets the shutter speed depending on the scene's brightness. Use high shutter speeds to record fast moving objects and low shutter speeds to record slow or stationary objects or objects in dimmer light.

-  Select the record mode by pressing the **MODE** button.  page 29

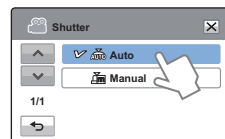
1. Touch the Menu () tab → "**Shutter**."
2. Touch the desired submenu item.
3. To exit the menu, touch the Exit () or Return () tab.



### Submenu items

- **Auto**: The camcorder automatically sets the appropriate shutter speed value.
- **Manual** (): Touch the decrease () or increase () tab to adjust the setting values. You can choose from the following settings: 1/50, 1/120, 1/250, 1/500, 1/1000, 1/2000, 1/4000, or 1/10000.









- The image may not seem smooth when you set a high shutter speed.
- When recording at a shutter speed of 1/1000 or lower, make sure the sun is not shining directly into the lens. As the shutter speed gets slower, the camcorder can be harmed by too much light.
- When you specify "**Shutter: Manual**," the **SCENE** mode is cancelled, "**Super C.Nite**" is set to "**Off**," and "**Aperture**" is set to "**Auto**" automatically.
- Even if the shutter speed is set to 1/10000, the camcorder supports only up to 1/2000 while recording photos.

## EV

Depending on the intensity of the ambient light, your videos and photos may be too bright or dark. Using the EV function, you can manually adjust video and photo image brightness.

 Select the record mode by pressing the **MODE** button. → page 29

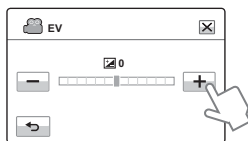

1. Touch the Menu () tab → “EV.”
2. Touch the decrease () or increase () tab to adjust the setting values. You can choose from the following settings:
  - EV values (): -2.0, -1.6, -1.3, -1.0, -0.6, -0.3, 0, +0.3, +0.6, +1.0, +1.3, +1.6, +2.0
3. To exit the menu, touch the Exit () or Return () tab.



## Super C.Nite



You can adjust the shutter speed when recording a slow moving object, or record a brighter image in dark places without a compromise in colours.

 Select the record mode by pressing the **MODE** button. → page 29

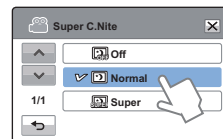
1. Touch the Menu () tab → “Super C.Nite.”
2. Touch the desired submenu item.
3. To exit the menu, touch the Exit () or Return () tab.



### Submenu items

- **Off**: Disables the function.
- **Normal** (): The shutter opens for 1/50 of a second in the normal mode and automatically switches to open for 1/25 of a second in a dark place. Use this function to get bright images in a dark place.
- **Super** (): The shutter opens for 1/13 of a second regardless of surrounding conditions. Use this function to get bright images in a darker place.

### Understanding EV (Exposure Value)

Exposure value is the total amount of light allowed to fall on the photographic medium (Image sensor) during the process of taking photos or videos. The higher the number, the greater the exposure. For example, + 0.3 lets in more light than -0.3.





Darker (-)  Brighter (+)



## Focus



The camcorder usually focuses on a subject automatically (auto focus). When you turn the camcorder on, focus is always set to automatic. You can also set the focus manually.

 Select the record mode by pressing the **MODE** button. [→ page 29](#)

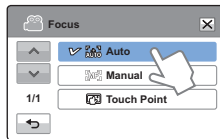

1. Touch the Menu (  ) tab → "Focus."
2. Touch the desired submenu item.
3. To exit the menu, touch the Exit (  ) or Return (  ) tab.







### Submenu items

- **Auto:** In most situations, it is better to use the automatic focus feature, as it lets you concentrate on the creative side of your recording.
- **Manual (MF):** You may need to focus manually under conditions in which automatic focusing is difficult or unreliable. Touch (  ) or (  ) tab to adjust the focus.
- **Touch Point (TP):** To focus on a subject shown on the LCD screen, simply touch the subject on the screen.

## Focusing manually during recording

Your camcorder automatically focuses a subject from close-up to infinity. However, the camcorder may not focus correctly, depending on the recording conditions. If it does not focus correctly, use the manual focus mode. To adjust the focus, place and hold your finger on the (  ) for a nearer subject, and on the (  ) tab for a farther subject.

- The nearer or farther icon (  /  ) appears in the centre when focus adjustment reaches the end.
- The camcorder applies the adjusted value right after you touch the (  ) or (  ) tab.

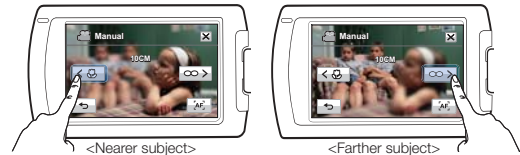

### Scenes to set focus manually for

- Scenes containing several objects, some close to the camcorder, others farther away.
- Scenes with a person enveloped in fog or surrounded by snow.
- Scenes which contain very shiny or glossy surfaces such as that of a car.
- Scenes with people or objects moving constantly or quickly such as athletic events or crowd scenes.

## Using the touch point function

Using the Touch Point function, you can have the camcorder focus on a small section of the picture. You get the camcorder to focus on a particular point by touching the desired point on the LCD screen.

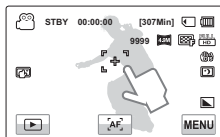

### To activate the touch point with a long touch

You can activate touch point by lightly pressing a particular point on the LCD screen for about 2 seconds.



- The Auto Focus (AF) setting is useful when you operate the zoom function because you might not be able to keep accurate focus after the zoom ratio has been changed.
- In the manual focus setting menu screen, you can access auto focus by touching the AF (AF) tab on the screen. You can return to manual focus by touching the manual focusing tabs.
- If you have enabled the Touch Point function, you can reset the focus to **Auto** by touching the AF (AF) tab on the LCD screen.

## Digital Effect

Using the Digital Effect function gives your recording a creative look.



- Select the record mode by pressing the **MODE** button. → page 29

1. Touch the Menu (MENU) tab → "Digital Effect."
2. Touch the desired submenu item.
3. To exit the menu, touch the Exit (X) or Return (↩) tab.

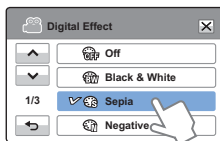

## Examples of 9 Digital Effect options



### Off

Without any Digital Effect, the image retains a normal, natural look.



### Black & White (☑)

This mode changes the image to black and white.



### Sepia (☑)

This mode gives the image an old-time, reddish brown look.



### Negative (☑)

This mode reverses the colours, creating a negative image.



### Art (☑)

This mode helps adjust for facial imperfections.



### Ghost (☑)

This mode helps the image have afterimage effect like ghosts moving around.



### Dazzle (☑)

This mode changes the images brighter by raising Saturation.



### Noir (☑)

This mode changes the images impressive by highlight contrast.



### Western (☑)

The mode change the image to faded and old film look.

## Fader

You can give your recording a professional look by using special effects such as fade in at the beginning of a sequence or fade out at the end of a sequence.

1. Touch the Menu (MENU) tab → “Fader.”
2. Touch the desired submenu item.
3. To exit the menu, touch the Exit (X) or Return (↩) tab.

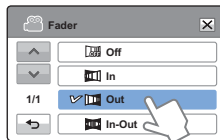

### Submenu items

- **Off**: Disables the function
- **In** (In): As soon as you start recording, the recording fades in.
- **Out** (Out): When the recording is done, it fades out.
- **In-Out** (In-Out): When you start or stop recording, the recording fades in or fades out accordingly.

### Recording a video with Fade effect

#### Fade in

With “Fader” set to “In,” press the **Recording start/stop** button. The recording starts with a dark screen, and then the image and sound fade in.

#### Fade out

With “Fader” set to “Out,” press the **Recording start/stop** button to stop recording. The image and sound fade out, the screen goes black, and then the recording stops.

#### Fade in-out

With “Fader” set to “In-Out,” press the **Recording start/stop** button. The recording starts with a dark screen, and then the image and sound fade in.

To stop recording, press the **Recording start/stop** button.

The image and sound fade out, the screen goes black, and then the recording stops.

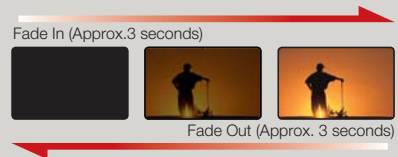

The camcorder automatically turns the Fader function off after it has been used once. You must reset it each time you want to use it.

## Tele Macro

Using the Tele Macro function, you can get close up images which are created by focusing on a small portion of a large object at a tele angle. It is useful to get close up images of flowers or insects etc.

- ☑ Select the record mode by pressing the **MODE** button. → page 29

1. Touch the Menu ( **MENU** ) tab → "Tele Macro."
2. Touch the desired submenu item.
3. To exit the menu, touch the Exit ( **X** ) or Return ( **↩** ) tab.

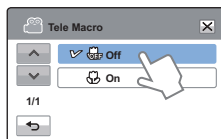

### Submenu items

- **Off:** Disables the function.
- **On (  ): You can focus on a small portion of a large object at a tele angle.**

- ☑ When recording in Tele Macro mode, the focus speed may be lowered.
- Use a tripod (not supplied) to prevent camcorder shake in the Tele Macro mode.
- Avoid shadows when recording in the Tele Macro mode.
- As the distance to the subject decreases, focusing area narrows.
- If you cannot get proper focus, move the Zoom lever to W(Wide) slowly and adjust the distance to the subject.
- When using the zoom to telephoto in the Tele Macro mode, the minimum distance you can have between the camcorder and subject is 50 cm.

## Cont. Shot



The Continuous Shot function lets you capture up to eight photos in rapid succession to give you more photo-taking opportunities when recording moving subjects.

- ☑ Select the record mode by pressing the **MODE** button. → page 29

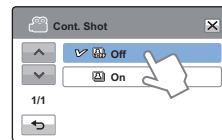
1. Touch the Menu ( **MENU** ) tab → "Cont. Shot."
2. Touch the desired submenu item.
3. To exit the menu, touch the Exit ( **X** ) or Return ( **↩** ) tab.



### Submenu items

- **Off:** The camcorder records only one photo image.
- **On (  ): When you press the PHOTO /  (My Clip) button, the camcorder can take up to 8 photos in one second.**

- ☑ If an error occurs (Card full, etc.) during continuous shot, the recording stops and an error message appears.
- When "Cont. Shot" is "On," the camcorder fixes the photo resolution at 1920x1080.

## Wind Cut

Using the Wind Cut function, you can reduce wind noise when recording sound using the internal microphone.

 Select the record mode by pressing the **MODE** button. →page 29

1. Touch the Menu (  ) tab →  
“Wind Cut.”

2. Touch the desired submenu item.

3. To exit the menu, touch the Exit (  ) or Return (  ) tab.

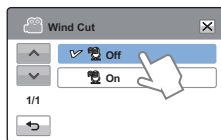

### Submenu items

- **Off:** Disables the function.
- **On (  ):** Reduces wind noise when recording sound using the internal microphone.

 Using the Wind Cut function also removes some low frequency sound with the wind noise.

## Digital Zoom

The digital zoom enables higher zoom magnification than the optical zoom. Digital zoom can electronically magnify an image created by the optical lens up to 300 times.

 Select the record mode by pressing the **MODE** button. →page 29

1. Touch the Menu (  ) tab →  
“Digital Zoom.”

2. Touch the desired submenu item.

3. To exit the menu, touch the Exit (  ) or Return (  ) tab.

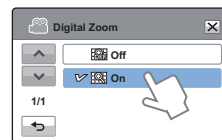

The right side of the bar shows the digital zooming zone. The zooming zone appears when you move the zoom lever.

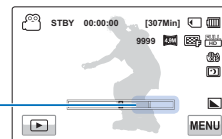

### Submenu items

- **Off :** Disables Digital Zoom.
- **On :** Enables higher digital zoom magnification.

 When you use the digital zoom, the camcorder processes the image digitally more than in the optical zoom mode. As a result, the image resolution may deteriorate.

## Self Timer

When you enable the self-timer, there is a time delay of 10 seconds before recording starts.

You can record videos or take photos of yourself.

- ☑ Select the record mode by pressing the **MODE** button. → page 29

1. Touch the Menu (MENU) tab → “Self Timer.”
2. Touch the desired submenu item.
3. To exit the menu, touch the Exit (X) or Return (↩) tab.

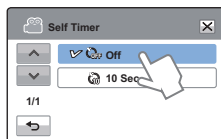

### Submenu items

- **Off:** Disables the Self Timer.
- **10 Sec (📷):** There is a time delay of 10 seconds after you press the **Record Start/Stop** or **PHOTO / 📷 (My Clip)** button.

- 📝 The camcorder automatically turns the Self Timer function off after it has been used once. You must turn it on each time you want to use it.

## Art Time Lapse REC

Using the Art Time Lapse function, you can set the camcorder to add emotion and something different experience on a dry and boring time lapse video.

- ☑ Select the record mode by pressing the **MODE** button. → page 29

1. Touch the Menu (MENU) tab → “Art Time Lapse REC.”
  - The menu screen appears.
2. Touch the desired submenu.
3. Touch the desired items (Interval, Rec Limit) and then touch the up (▲) or down (▼) tab to set the values.

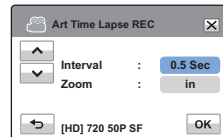
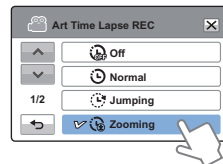

4. Touch the (OK) tab to finish the setting.
5. To exit the menu, touch the Exit (X) or Return (↩) tab.

6. After setting the Art Time Lapse REC mode, press the **Recording start/stop** button.

- The Art Time Lapse REC starts.
- Art Time Lapse REC only supports the [HD]720/50P resolution and Super Fine quality.
- Press the **Recording start/stop** button if you want to stop the Art Time Lapse mode.

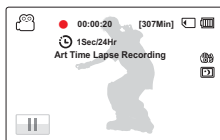

Icon	Description
	<p><b>Normal:</b> Set to record frames at an interval that you define.</p> <ul style="list-style-type: none"> <li>• <b>Interval:</b> An image of a scene is captured once every 0.1, 0.5, 1, 3, or 5 seconds.</li> </ul>
	<p><b>Jumping:</b> Set to record frames of a jumping time lapse video at an interval that you define.</p> <ul style="list-style-type: none"> <li>• <b>Interval:</b> The scene is recorded for 3 seconds in every 1, 3, 5, 10, or 20 seconds. Audio is also recorded.</li> </ul>
	<p><b>Zooming:</b> Set a zoom effect for a time lapse video.</p> <ul style="list-style-type: none"> <li>• <b>Interval:</b> An image of a scene is captured once every 0.1, 0.5, 1, 3, or 5 seconds.</li> <li>• <b>Zoom:</b> Adds the zoom in/out effect to a time lapse video.</li> </ul>
	<p><b>Panning:</b> Set a panning effect for a time lapse video.</p> <ul style="list-style-type: none"> <li>• <b>Interval:</b> An image of a scene is captured once every 0.1, 0.5, 1, 3, or 5 seconds.</li> <li>• <b>Direction:</b> Adds the panning effect (left/right/up/down) to a time lapse video.</li> </ul>
	<p><b>Zooming + Panning:</b> Set a zoom and panning effect to add them simultaneously.</p> <ul style="list-style-type: none"> <li>• <b>Interval:</b> An image of a scene is captured once every 0.1, 0.5, 1, 3, or 5 seconds.</li> <li>• <b>Direction:</b> Adds the panning effect (left/right/up/down) to a time lapse video.</li> <li>• <b>Zoom:</b> Adds the zoom in/out effect to a time lapse video.</li> </ul>

### Example of Art Time Lapse recording

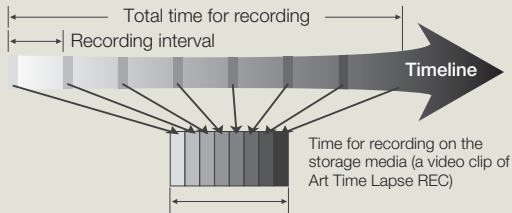

The Art Time Lapse function records image frames at a predefined interval over the total recording time to produce a time-lapse video.

Art Time Lapse is useful for filming the following subjects:

- Blooming flowers
- A bird building a nest
- Clouds rolling in by the sky

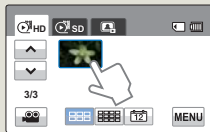

- During Art Time Lapse recording, the Super C.Nite function does not work.
- Art Time Lapse recording is turned off once recording is finished. To start another Art Time Lapse mode, repeat steps 1 to 7.
- 25 captured images compose a video of 1 second length. Since the minimum length of a video that your camcorder can save is one second, the interval defines the total minimum recording time for the Art Time Lapse mode. For example, if you set the interval to **5 Sec**, you need to set the recording time for the Art Time Lapse mode to at least 2 minutes and 30 seconds to record a minimum video length of 1 second (25 images).
- You cannot pause recording during Time lapse recording.
- Audio is not recorded during Art Time Lapse recording. (Audio is recorded only during Jumping recording in Art Time Lapse mode.)
- The maximum video file size is 1.8GB. When a video file exceeds 1.8GB, a new video file is created automatically.
- We recommend using the power adaptor instead of the battery for Art Time Lapse.
- If the battery charge is exhausted during Art Time Lapse recording, the camcorder saves recording up to that point and switches to standby mode. After a while, it displays a warning message, and then turns off automatically.
- If the storage media becomes full during Art Time Lapse recording, the camcorder switches to the standby mode after saving the recording up to the maximum memory available.
- Art time lapse Recording will automatically terminate after 72 hours.

## Quick View

Using the Quick View function, you can view the most recently recorded video or photo images immediately after you have recorded them.

 Select the record mode by pressing the **MODE** button.  page 29



1. Touch the Menu (  ) tab →  
"Quick View."

2. Touch the desired submenu item.

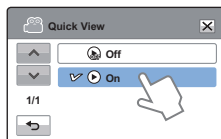
3. To exit the menu, touch the Exit (  ) or Return (  ) tab.



### Submenu items

- **Off:** Quick View (  ) icon does not appear on the screen after you finish the recording.
- **On:** Quick View (  ) icon appears on the screen as soon as you finish the recording. Touch the Quick View icon to view the most recent video or photo you have recorded. After the Quick View is completed, your camcorder switches back to the standby mode.

### Deleting files after Quick View

If you touch the delete (  ) tab during Quick View, the file you are viewing is deleted.





- The Quick View function is not available under the following conditions:
  - If the mode has been changed after the recording
  - If the USB cable is connected to the camcorder.
  - If the camcorder has been restarted after the recording
  - After playing Quick View
- For photos recorded with "Cont. Shot," only the last file in the sequence is displayed.

# Advanced playback

## Guideline



This camcorder provides 3 types of guidelines to help you to set a balanced image composition on the screen.

 Select the record mode by pressing the **MODE** button. →page 29

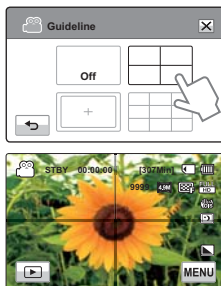
1. Touch the Menu (  ) tab → "Guideline."
2. Touch the desired guideline according to the subject.
  - The selected guideline appears on the screen.
3. To exit the menu, touch the Exit (  ) or Return (  ) tab.





### Submenu items



- **Off**: Disables the function.
- : Placing the subject at the centre cross point puts the subject in the middle of the frame.
- : Positioning subjects within the Safety Zone rectangle ensures they will be recorded.
- : For recording multiple subjects. Putting subjects at or near the grid cross points creates a balanced composition.

-  • Positioning a subject at the cross point of a guideline provides a balanced composition.
- Guidelines are not recorded.

## Play Option







You can select a specific video playback option.

 Select the Play (  ) tab on the LCD screen to select the Video play (  /  ) mode. →page 45

1. Touch the Menu (  ) tab → "Play Option."
2. Touch the desired submenu item.
3. To exit the menu, touch the Exit (  ) or Return (  ) tab.





### Submenu items

- **Play All** (  ): Plays video clips in succession starting from a video you select and ending at the last video you recorded, then returns to the thumbnail index view.
- **Play One** (  ): Plays the selected video once, and then returns to the thumbnail view.
- **Repeat All** (  ): Plays all the video clips repeatedly until you touch the Return (  ) tab.
- **Repeat One** (  ): Plays one selected video repeatedly until you touch the Return (  ) tab.

## Highlight



The Highlight function plays a portion of each recorded video at random.

Select the Play (  ) tab on the LCD screen to select the Video play (  /  ) mode. → page 45

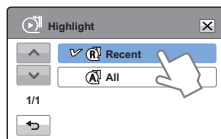
1. Touch the Menu (  ) tab. → "Highlight."
2. Touch the desired submenu item.
3. To exit the menu, touch the Exit (  ) or Return (  ) tab.



### Submenu items

- **Recent** (  ): Plays a portion of all videos created within the last 24 hours.
- **All** (  ): Plays a portion of all video files.

### Highlight playback time to the duration of a video

Video Duration	Highlight playback time
Less than 5 sec.	Full playback
5 to 30 sec.	Plays 5 seconds at random.
30 sec. to 5 min.	Plays 5 seconds of each 30 second section at random.
5 min. to 10 min.	Plays 11 seconds of each 2 minute section at random.
Over 10 min.	Plays 15 seconds of each 3 minute section at random.

- If you run the Highlight function in the date thumbnail display, Highlight plays random portions of all the files in the selected date set.
- In the Highlight play mode, you can adjust the volume by touching the screen. You can also cancel the playback.





## Slide Show Option

You can set the play options for the slide show with the slide show setting menus.

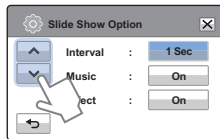
- Select the Play (  ) tab on the LCD screen to select the photo (  ) mode. ↪page 45

1. Touch the Menu (  ) tab. → “Slide Show Option.”



2. Touch the desired submenu item and touch the (  )/(  ) tab to set the value you want.
3. To exit the menu, touch the Exit (  ) or Return (  ) tab.

### Submenu items

- **Interval:** Continuously plays back photos at the interval you select. You can choose 1 sec. or 3 sec.
- **Music:** You can turn the internal background music on or off. This camcorder has 7 default background melodies stored in the boot-up flash memory. When music is On, starting a slide show starts the play back of the 7 melodies in shuffle mode.
- **Effect:** Continuously plays back photos using the fade in / out effect to transition between images.

## File Info

You can see the image information for all images.

- Select the Play (  ) tab on the LCD screen to select the Video play (  HD /  SD ) or Photo play (  ) mode. ↪page 45

1. Touch the Menu (  ) tab → “File Info.”

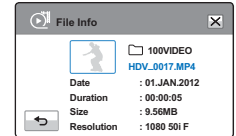

2. Select the file you want to view the file information for.
  - The information of the selected file appears.
3. To exit the menu, touch the Return (  ) tab.

# Editing files

## Delete

You can erase your recordings one by one or all at once.

- ✓ Insert a memory card. ↪ page 34
- ✓ Set the appropriate storage media. (HMX-H405 only) ↪ page 33
- ✓ Touch the Play (▶) tab on the LCD screen to select the play mode. ↪ page 45

1. Touch the HD (HD), SD (SD), or Photo (Photo) tab.

- Videos or photos appear as thumbnails.

2. Touch the Menu (MENU) tab → “Delete” → touch the desired submenu item.

- If you touch “Select Files,” you will see image thumbnails. Go to Step 3.
- If you touch “All Files,” you will see the message that corresponds to that option. Go to Step 4.

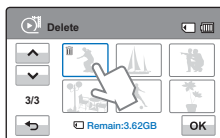
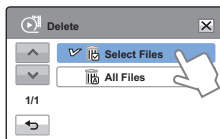

3. Touch the files you want to delete. After you have selected all the files you want to delete, touch the (OK) tab. Go to Step 4.

- See Submenu items below for additional details.

4. Touch “Yes.”

- If you selected “All Files,” the camcorder deletes all the files in the storage media, except for those that are protected.
- If you selected “Select Files,” the camcorder deletes the files you selected.

### Submenu items

- **Select Files:** Deletes individual images.
  - ① Touch the images you want to delete. The indicator (III) is displayed on the selected images. Touching the thumbnail image toggles the image between being selected for deletion (III) or not selected.
  - ② Touch the (OK) tab. The selected images are deleted.
- **All Files:** Deletes all images.

- ⚠ Deleted images cannot be recovered.
- Do not eject a memory card or power off the camcorder while deleting videos or photos recorded on the storage media. Doing so may damage the storage media or data.

- ✎ You can also operate this function in the full and single image display modes.
- To protect important images from accidental erasure, activate the image protection function in advance. ↪ page 73
- You cannot delete protected files. Cancel the protect function first. ↪ page 73
- If the write protection tab on the memory card is set to lock, you cannot delete images.
- The delete function does not work if the battery charge is insufficient. We recommend you use the AC adaptor to ensure the camera has continuous power when deleting.

## Delete My Clip

You can delete the My Clip tags from a video tagged as 'My Clip'.

- ✓ Insert a memory card. ↪ page 34
- ✓ Set the appropriate storage media. (HMX-H405 only) ↪ page 33
- ✓ Select the Play (▶) tab on the LCD screen to select the Video play (▶/SD) mode. ↪ page 45

1. Touch a thumbnail tagged as My Clip (▶).
2. Touch the Menu (MENU) tab → "Delete My Clip."
3. Touch "Yes."
  - The camcorder will delete all My Clip tags from the video.

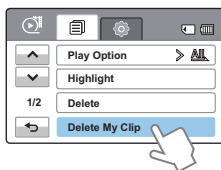

## My Clip Creation

You can extract the exciting scenes tagged as 'My Clip' from a video and create one file with them.

- ✓ Insert a memory card. ↪ page 34
- ✓ Set the appropriate storage media. (HMX-H405 only) ↪ page 33
- ✓ Select the Play (▶) tab on the LCD screen to select the Video play (▶/SD) mode. ↪ page 45

1. Press the **PHOTO / ▶ (My Clip)** button in the video thumbnail view.
2. Touch the desired submenu item.



### Submenu items

- **Creation Start:** Combines the tagged scenes sequentially, saves and locates it as a video at the last file position on the video thumbnail view.
- **Preview:** Previews the tagged scenes sequentially.

- ✗ While previewing the scenes tagged as 'My Clip', you cannot drag the progressive bar on the LCD screen.
- If there is not enough storage space available in the media storage to create new files from tagged videos tagged as 'My Clip' the Creation Start tab will be dimmed.

## Protect

You can protect important recordings from accidental erasure. The protected videos and photos cannot be deleted unless you format the memory card or cancel the protection.

- ✓ Insert a memory card. ↪page 34
- ✓ Set the appropriate storage media. (HMX-H405 only) ↪page 33
- ✓ Touch the Play (▶) tab on the LCD screen to select the play mode. ↪page 45

1. Touch the HD (HD), SD (SD), or Photo (Photo) tab.

- Videos or photos appear as thumbnails.

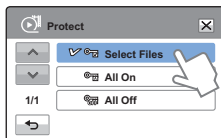

2. Touch the Menu (MENU) tab → "Protect" → touch the desired submenu item.

- If you touch "Select Files," you will see image thumbnails. Go to Step 3.
- If you touch "All Files," you will see the message that corresponds to that option. Go to Step 4.

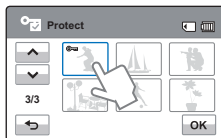

3. Touch the files you want to protect. After you have selected all the files you want to protect, touch the (OK) tab. Go to Step 4.
- See Submenu items below for additional details.

4. Touch "Yes."

- If you selected "All On," the (lock) indicator appears on all files.
- If you selected "All Off," the (lock) indicator disappears from all protected files.
- If you selected "Select Files," the indicator appears on the files you selected for protection and disappears from the files you removed protection from.

### Submenu items

- **Select Files:** Protects individual images.
  - ① Touch the images to protect from erasure. The (lock) indicator appears on the selected images. Touching the thumbnail image toggles the image between being selected (lock) or not selected.
  - ② Touch the (OK) tab.
- **All On:** Protects all images.
- **All Off:** Turns off protection on all protected images all at once.



- You can also operate this function in the full and single image display modes.
- If the write protection tab on the memory card is set to lock, you cannot set this function. ↪page 35

## Copy (HMX-H405 only)

Videos and photos stored in the internal memory can be copied to the external flash memory card. Copying to the memory card does not delete the originals in the internal memory.

- ✓ Insert a memory card. ↪ page 34
- ✓ Touch the Play tab (⏮) on the LCD screen to select the play mode. ↪ page 45

1. Touch the HD (HD), SD (SD) or Photo (Photo) tab.
  - Videos or photos appear as thumbnails.
2. Touch the Menu (MENU) tab → "Copy."
3. Touch the desired submenu item.
4. The message that corresponds to the selected option appears. Touch "Yes."
  - The selected images are copied.

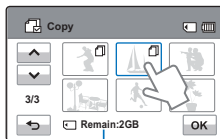
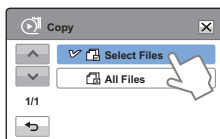

Remaining free space in the destination memory card

### Submenu items

- **Select Files:** Copy individual images. Touch the images you want to copy. The (☑) indicator is displayed on the selected images. Touching the thumbnail image toggles the image between being selected (☑) or not selected. Touch the (OK) tab. The selected images are copied.
- **All Files:** Copy all images.



- You can also operate this function in the full and single image display mode.
- If the write protection tab on the memory card is set to lock, you cannot copy the images. ↪ page 35
- You cannot copy a file if the memory card has insufficient free space. Remove unnecessary files before proceeding. ↪ page 103
- The copy function does not work if the battery charge is insufficient. We recommend you use the AC adaptor to ensure the camera has continuous power when copying.

## Divide

You can divide a video into two, and easily delete a section you no longer need. As this function edits the original file, make sure to back up the original before dividing it.

- ✓ Insert a memory card. ↪page 34
- ✓ Set the appropriate storage media. (HMX-H405 only) ↪page 33
- Select the Play (▶) tab on the LCD screen to select the Video play (C/HD / C/SD) mode. ↪page 45

1. Touch the Menu (MENU) tab → “Edit” → “Divide.”

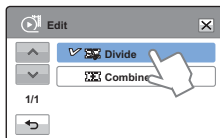

2. Touch the video you want to edit.  
• The selected video is displayed as paused.

3. Search for the point of division by touching the playback control tabs.

- Playback control tabs: ▶
- / || / ◀ / ▶ / ◀ / ▶

4. Touch the pause (||) tab at the point of division, and then touch the Cutting (✂) tab.

- A message appears asking for your confirmation.

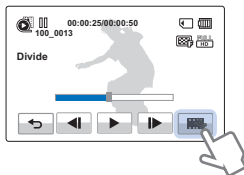

5. Touch “Yes.”

- The video you selected is divided into two video clips.
- The second clip of the divided video is displayed as the last thumbnail.
- After the division, you can partially delete an unnecessary section or combine it with other videos.

⚠ Do not eject a memory card or power off the camcorder while editing a video recorded on the storage media. Doing so may damage the storage media or data.

- ✍ • You can also operate this function in the full and single image display modes.
- You cannot divide files that are protected (Ⓢ). Cancel the protect function first. ↪page 73
- The divided video may drift before or after the division point by approximately 2 seconds.
- The Divide function is not available under the following conditions:
  - If the total recorded time of the video is less than 6 seconds.
  - If you try to divide sections without leaving 3 seconds at the beginning and the end.
  - If the remaining memory space on your memory card is less than 15MB.
  - When the number of files on the card reaches 9999.
- You cannot divide photos.
- When you divide a video with My Clip tags, the My Clip tags disappear.
- You cannot divide a video recorded in Art Time Lapse mode.

## Combine

You can combine two different videos. As this function edits the original files, make sure to back up the original files before combining them.

- ✓ Insert a memory card. ↪page 34
- ✓ Set the appropriate storage media.(HMX-H405 only) ↪page 33
- Select the Play (▶) tab on the LCD screen to select the Video play (▶HD / ▶SD) mode. ↪page 45

1. Touch the Menu (MENU) tab → "Edit" → "Combine."

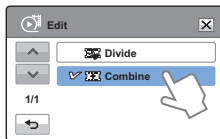

2. Touch the video thumbnails of the videos you want to combine in the order you want them combined.

- The (☑) indicator and the order number appear on the selected videos. Touching the video thumbnail toggles a video between being selected (☑) or not selected.
- The (☑) indicator does not appear if the video files have different resolutions.

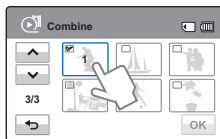

3. Touch the (OK) tab.

- A message appears asking for your confirmation.

4. Touch "Yes."

- The camcorder combines the video files you selected in the order you designated, and then stores the combined videos as a single video file.

⚠ Do not eject a memory card or power off the camcorder while editing a video recorded on the memory card. Doing so may damage the storage media or data.

- ✍ You cannot combine files that are protected (Ⓜ). Cancel the protect function first. ↪page 73
- The original videos are not preserved.
- The Combine function is not available under the following conditions:
  - If the Videos are in different resolution formats. For example, videos recorded at "Video Resolution: 1080/50i" and "Video Resolution: 720/50p" cannot be combined.
  - If the file size of the combined videos exceeds 1.8 GB.
  - If the remaining memory space on your memory card is less than 15MB.
  - If a video's file format is not supported by the camcorder.
  - When the camcorder is playing a video file.
- When you combine a video with My Clip tags, the My Clip tags disappear.
- You cannot combine a video recorded in Art Time Lapse mode.

# System setting

## SETTING MENU ITEMS

- Refer to page 50 for setting menus.
- For item operation details, go to the page number listed in the table under Page.

Items	Default value	Page
Storage Type*	Internal Memory	78
Storage Info*	-	78
Card Info**	-	78
File No.	Series	79
Time Zone	Home	79
Date/Time Set	01/JAN/2012 00:00 (Summer Time : Off)	80
Date Type	01/JAN/2012	80
Time Type	24 Hr	80
Date/Time Display	Off	81
Auto LCD Off	On	81
Beep Sound	On	82
Shutter Sound	On	83
Auto Power Off	5 Min	83
Quick On STBY	Off	84
PC Software	On	84
USB Connect	Mass Storage	85
HDMI TV Out	Auto	86
TV Connect Guide	-	86
TV Display	On	87
Format	-	87
Default Set	-	88
Language	English	88
Demo	On	89
Anynet+(HDMI-CEC)	On	89



- Menu options and default values may be changed without prior notice.
- The time type may change depending on the language you selected.
- Items marked with \* are available only with HMX-H405 model.
- Items marked with \*\* are available only with HMX-H400 model.

## Storage Type (HMX-H405 only)

You can record videos and photos on the internal memory or a memory card.

Select the desired storage media before starting recording or playback. ▶page 33

## Storage Info (HMX-H405 only)

This function shows you the storage information of the selected storage media, such as used and available memory space, etc.

 Insert a memory card in the camcorder before viewing the storage information.

1. Touch the Menu (  ) → Setting (  ) tab → "Storage Info."

2. Touch the desired submenu item.

- Use memory space, available memory space, and recordable time appears. Available space and recordable time depend on the video resolution you've selected.

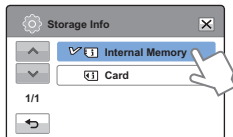

3. To exit the menu, touch the Exit (  ) or Return (  ) tab.

### Submenu items

- **Internal Memory:** Displays the storage information of the internal memory.
- **Card:** Displays the storage information of the memory card.

## Card Info (HMX-H400 only)

This function shows you the storage information of the memory card, such as used memory space, available memory space, etc.

 Insert a memory card. ▶page 34

1. Touch the Menu (  ) → Setting (  ) tab → "Card Info."

- Used memory space, available memory space, and recordable time appear. Available space and recordable time depend on the video resolution you've selected.

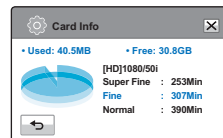

2. To exit the menu, touch the Return (  ) tab.

## File No.

File names (numbers) are assigned to recorded images according to the numbering option you select.

1. Touch the Menu (MENU) → Setting (⚙️) tab → "File No."
2. Touch the desired submenu item.
3. To exit the menu, touch the Exit (✕) or Return (↩️) tab.

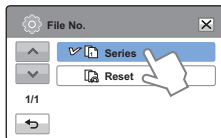

### Submenu items

- **Series:** Assigns file numbers in a continuous sequence even after you replace or format the storage media or delete all files. Each file is given a unique file number that allows convenient image management on a PC.
- **Reset:** Resets the file number to 0001 after you format the memory card, delete all files, or insert a new memory card.



When you set "File No." to "Series," the camcorder assigns each file a different number to avoid duplicating file names. This is useful when you want to manage your files on a computer.

## Time Zone

You can set the clock to the local time when using your camcorder in a different time zone.

### Setting the local time

1. Touch the Menu (MENU) tab → Setting (⚙️) tab → "Time Zone" → "Visit."
2. Touch the left (←) or the right (→) tab to select the visited area.
3. Touch the (OK) tab when the time zone setting is complete.
  - The camcorder does not apply the time zone you set if you finish the setting by touching the (OK) tab without touching the (↩️) tab.

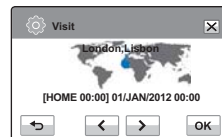

### Submenu items

- **Home:** The camcorder displays the time according to your settings on the Date/Time Set menu. Select Home when using the camcorder for the first time or when returning the clock to your hometown date/time setting.
- **Visit (📍):** When you visit a local in a different time zone, the Visit function allows you to use the local time without changing your hometown time setting. The camcorder adjusts the clock in accordance with the time difference between the two locations.

## Date/Time Set

By setting the date and time, you can display the date and time of the recording during playback.

→ page 31



## Date Type

You can set the display format for the date.

1. Touch the Menu (MENU) → Setting (⚙️) tab → “Date Type.”
2. Touch the desired submenu item.
3. To exit the menu, touch the Exit (⌫) or Return (↩️) tab.

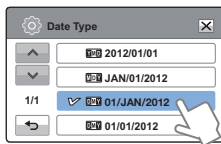

### Submenu items

- **2012/01/01**: Displays the date in the year/month (two-digit)/day format.
- **JAN/01/2012**: Displays the date in the month/day/year format.
- **01/JAN/2012**: Displays the date in the day/month/year format.
- **01/01/2012**: Displays the date in the day/month (two-digit)/year format.

## Time Type

You can set the display format for the time.

1. Touch the Menu (MENU) → Setting (⚙️) tab → “Time Type.”
2. Touch the desired display option.
3. To exit the menu, touch the Exit (⌫) or Return (↩️) tab.

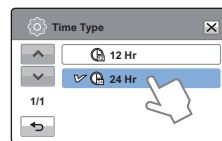

### Submenu items

- **12Hr**: Displays the time information in 12 hour units.
- **24Hr**: Displays the time information in 24 hour units.





This function depends on the “Date/Time Display” setting. → page 81



## Date/Time Display

You can set whether or not the date and/or time are displayed on the LCD screen.

 Before you use the **"Date/Time Display"** function, you must set the date and time. [▶page 31](#)

1. Touch the Menu () → Setting () tab → **"Date/Time Display."**

2. Touch the desired submenu item.

3. To exit the menu, touch the Exit () or Return () tab.

- The date/time is displayed on the LCD screen according to the selected option.

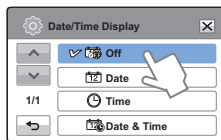

### Submenu items

- **Off:** Current date/time information is not displayed.
- **Date:** Displays the current date.
- **Time:** Displays the current time.
- **Date & Time:** Displays the current date and time.

-  • The date/time will read **"01/JAN/2012 00:00"** in the following case:
  - When the internal rechargeable battery is depleted.
- This function depends on the **"Date Type"** and **"Time Type"** setting. [▶page 80](#)

## Auto LCD Off

To reduce power consumption, the camcorder automatically dims the brightness of the LCD screen if the camcorder is idle for a period of time.

1. Touch the Menu (MENU) → Setting (⚙️) tab → "Auto LCD Off."
2. Touch the desired submenu item.
3. To exit the menu, touch the Exit (✖️) or Return (↩️) tab.

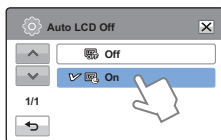

### Submenu items

- **Off:** Disables the function.
- **On:** When the camcorder is idle for more than 2 minutes in the STBY mode, or for more than 5 minutes when recording a video, the power saving mode starts by dimming the LCD screen.

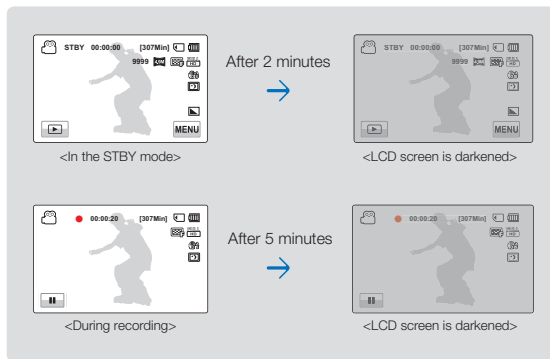

- When the "Auto LCD Off" function is enabled, you can press any button on the camcorder to return LCD brightness to normal.
- Auto LCD Off is disabled in the following cases:
  - If the AC power adaptor is connected.
  - While the Demo function is in operation.
  - When the camcorder has a cable connection (Audio/Video cable, HDMI cable, etc.).

## Beep Sound

The Beep Sound function lets you control whether a beep sounds when you touch certain buttons on the screen.

1. Touch the Menu (MENU) → Setting (⚙️) tab → **“Beep Sound.”**
2. Touch the desired submenu item.
3. To exit, touch the Exit (⌫) or Return (↩️) tab until the menu disappears.

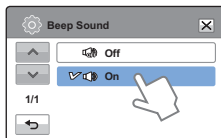

### Submenu items

- **Off:** Disables the function.
- **On:** You will hear a beep when pressing buttons or tabs such as the **Power** (⏻) button or **Recording start/stop** button.

-  The Beep Sound is canceled in the following cases:
- During recording and playback.
  - When the camcorder has a cable connection (Audio/Video cable, HDMI cable, etc.).

## Shutter Sound

The Shutter Sound function lets you turn the shutter sound that plays when you press the **PHOTO / 📷 (My Clip)** button on or off.

1. Touch the Menu (MENU) → Setting (⚙️) tab → **“Shutter Sound.”**
2. Touch the desired submenu item.
3. To exit the menu, touch the Exit (⌫) or Return (↩️) tab.

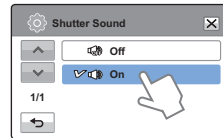

### Submenu items

- **Off:** Disables the function.
- **On:** You will hear the shutter sound when you press the **PHOTO / 📷 (My Clip)** button.

-  The camcorder does not make the shutter sound:
- If you press the **PHOTO / 📷 (My Clip)** button during video recording.
  - When the camcorder has a cable connection (Audio/Video cable, HDMI cable, etc.).

## Auto Power Off

You can set your camcorder to turn off automatically if it is idle for 5 minutes without an operation. This function prevents unnecessary power consumption.

1. Touch the Menu (MENU) → Setting (⚙️) tab → **"Auto Power Off."**
2. Touch the desired submenu item.
3. To exit the menu, touch the Exit (⌂) or Return (↩️) tab.

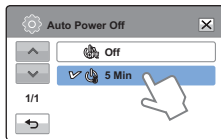

### Submenu items

- **Off:** Disables the function.
- **5 Min:** The camcorder turns off if idle for 5 minutes without an operation.



- Auto Power Off does not work in the following situations:
  - When the camcorder has a cable connection. (USB cable, AC power adaptor, etc.)
  - While the Demo function is in operation.
  - While you are recording, playing (except pause), or running a photo slide show.
- To turn the camcorder on again, press the **Power** (⏻) button.

## Quick On STBY

When you are going to record frequently for an extended time, use the Quick On STBY function to reduce energy consumption and battery drain.

With the Quick On STBY function On, closing the LCD screen starts Quick On STBY.

1. Touch the Menu (MENU) → Setting (⚙️) tab → **"Quick On STBY."**
2. Touch the desired submenu item.
3. To exit the menu, touch the Exit (⌂) or Return (↩️) tab.

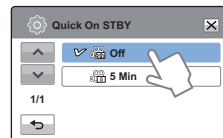

## Submenu items

- **Off:** Closing the LCD screen turns off the camcorder.
- **5 Min:** Closing the LCD screen starts the Quick On STBY mode after a short period of time. The camcorder stays in Quick On STBY mode for 5 minutes and then turns off unless you open the LCD screen or push a button.



- We recommend turning off the camcorder after use to reduce energy consumption. However, as an alternative, you can use the Quick On STBY function under most shooting conditions to reduce energy consumption effectively.
- The mode indicator keeps blinking in the Quick On STBY mode.
- The Quick On STBY mode is not available under the following conditions:
  - When the LCD screen is open.
  - When a video cable (HDMI, Audio/Video cable) or the USB cable is connected to the camcorder.
  - When you operate the buttons on the camcorder.

## PC Software

If you set PC Software to On, you can use the PC software built into the camcorder (Intelli-studio) by connecting your camcorder to your PC using the camcorder's USB cable. You can download the video and photo images stored on the camcorder to your PC's hard disk and edit the videos and photos using the internal PC software.

1. Touch the Menu (MENU) → Setting (⚙️) tab → **"PC Software."**
2. Touch the desired submenu item.
3. To exit the menu, touch the Exit (⌫) or Return (↩️) tab.

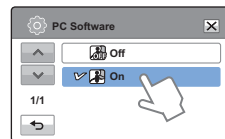

## Submenu items

- **Off:** Disables the PC Software function.
- **On:** The internal editing software starts when you connect the camcorder to a PC.



- The PC Software function is not available under the following conditions:
  - If **"USB Connect"** is set to **"PictBridge"**
- To enable the PC Software function, set **"USB Connect"** to **"Mass Storage,"** in the system setting menu option. ↪ page 86
- The PC Software is compatible with the Windows operating systems only.

## USB Connect

You can transfer data to a PC or print photos directly by establishing the correct USB connection.

1. Touch the Menu (MENU) → Setting (⚙️) tab → “USB Connect.”
2. Touch the desired submenu item.
3. To exit the menu, touch the Exit (⌂) or Return (↩️) tab.

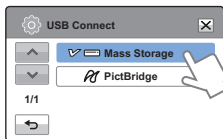

### Submenu items

- **Mass Storage:** Connect to a PC to transfer videos or photos. ↪ page 101
- **PictBridge:** Connect to a PictBridge printer to print photos directly (when using the PictBridge function). ↪ page 94

 Before connecting a USB cable, check whether the current USB mode is appropriate for the function you want to use.

## HDMI TV Out

You can set the HDMI video output to match the TV you have connected the camcorder to.

- Using the HDMI cable (not supplied), connect the camcorder to your TV. ↪ page 90

1. Touch the Menu (MENU) → Setting (⚙️) tab → “HDMI TV Out.”
2. Touch the desired submenu item.
3. To exit the menu, touch the Exit (⌂) or Return (↩️) tab.

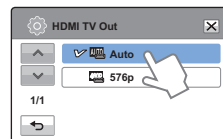

### Submenu items

- **Auto:** The video signals are output in the same format as the recorded file. Use this setting only when connecting to an HDTV.
- **576p:** The recorded file is output in the 720x576p format. Use this setting only when connecting to a standard, analogue TV which supports Standard Definition (SD) progressive scan through its the HDMI jacks.

## TV Connect Guide

You can view the TV Connect Guide before you connect the camcorder to your TV set.

1. Touch the Menu (MENU) tab → Setting (⚙️) tab → “TV Connect Guide.”
2. Touch the desired submenu item.
  - The TV Connect Guide appears depending on the selected submenu items.
  - Refer to the TV Connect Guide when you connect your camcorder to a TV.
3. To exit the menu, touch the Exit (⌫) or Return (↩️) tab.

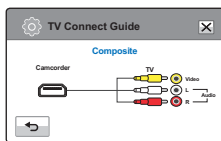
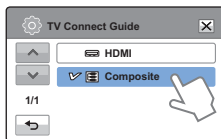

<To connect the Audio/Video cable>

### Submenu items

- **HDMI:** Select HDMI when connecting the camcorder to a TV with an HDMI cable.
- **Composite:** Select Composite when connecting the camcorder to a TV with a Video/Audio (composite) cable.

## TV Display

You can enable or disable the On Screen Display (OSD) that appears on the TV screen when you have connected your camcorder to a TV.

1. Touch the Menu (MENU) → Setting (⚙️) tab → “TV Display.”
2. Touch the desired submenu item.
3. To exit the menu, touch the Exit (⌫) or Return (↩️) tab.

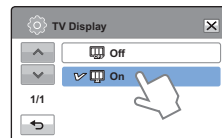

### Submenu items

- **Off:** The OSD (On Screen Display) menus are only shown on the LCD screen.
- **On:** The OSD menus are shown on the LCD screen and the TV screen as well.



The thumbnail display and Demo screens are shown on the TV even if you set “TV Display” to “Off.”

## Format

Use this function if you want to delete all files completely or to correct problems on the storage media.

 Insert a memory card. [page 34](#)

1. Touch the Menu (  ) → Setting (  ) tab → “**Format.**”

2. Touch the desired submenu item. (HMX-H405 only)

- A message appears asking about formatting the memory card.

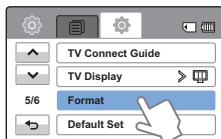

### Submenu items (HMX-H405 only)

- **Internal Memory:** Formats the internal memory.
- **Card:** Formats the memory card.

3. Touch “**Yes**” → “**Yes.**”

- The format is executed and the formatting message appears.



- Do not remove the storage media or perform any other operation (such as turning off the power) during formatting. Also, be sure to use the provided AC power adaptor to power the camcorder when formatting. The memory card may be corrupted if the battery becomes exhausted during formatting and the formatting process stops before the card is completely formatted.
- If the storage media becomes corrupted, format it again.



- Do not format the storage media on a PC or other device. Make sure to format the storage media on this camcorder.
- You cannot format a memory card with the protection tab set to lock. [page 35](#)
- If there is no storage media inserted, you cannot select the Format function, and its name will be dimmed on the menu.
- Formatting completely deletes all files and options on a memory card, including protected files. By deleting all files and options, formatting typically corrects problems, enabling stable read/write speeds and operation.
- Run memory card format by touching “**Format.**” (HMX-H400 only)

## Default Set

You can restore all menu settings to their factory default settings.

1. Touch the Menu (  ) → Setting (  ) tab → “**Default Set.**”

- A message appears asking for your confirmation.

2. Touch “**Yes**” if you want all the settings returned to the default.

- The Time Zone screen appears after all settings return to their defaults.

3. Set the date and time again. [page 31](#)



- Do not turn off the power while using this function.
- Initializing the camcorder settings to factory defaults does not affect recorded images.

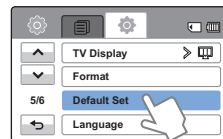





## Language

You can select a language in which to display the menu and messages. [page 32](#)



## Demo

Demo mode automatically shows you the major functions that are included with your camcorder so that you may use them more easily.

1. Touch the Menu (  ) → Setting (  ) tab → **"Demo."**
2. Touch the desired submenu item.
3. To exit the menu, touch the Exit (  ) or Return (  ) tab.

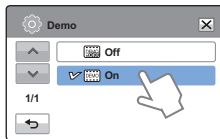

### Submenu items

- **Off:** Disable the Demo function.
- **On:** Enables the Demo function.



### Using the Demo function

You can easily operate demo function touching Menu (  ) tab for 5 seconds.

The Demo mode is canceled in the following cases:

- If the LCD screen is touched.
  - If you press any button (**Recording start/stop, Anti-shake (OIS), Display (  ), SMART AUTO, MODE, PHOTO, etc.**)
- However, the camcorder enters the Demo mode automatically after 5 minutes in STBY mode if it is idle for 5 minutes without an operation. If you don't want the Demo function to start, set **"Demo"** to **"Off."**







The Demo function does not operate in the following case:

- If you set **"Auto Power Off"** to **"5 Min"** and you are using the battery to power the camcorder, the Auto Power Off function turns the camcorder off before Demo can run.

## Anynet+(HDMI-CEC)

This camcorder supports Anynet+. Anynet+ is an AV network system that lets you control all connected Samsung AV devices with an Anynet+ supported Samsung TV remote control.

1. Touch the Menu (  ) → Setting (  ) tab → **"Anynet+(HDMI-CEC)."**
2. Touch the desired submenu item.
3. To exit the menu, touch the Exit (  ) or Return (  ) tab.

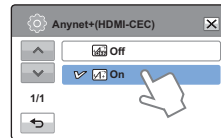

### Submenu items

- **Off:** Disables the function.
- **On:** The Anynet+ function is enabled.  
When the camcorder is connected to an Anynet+ supported TV, you can operate some functions of the camcorder using the TV's remote control.



- When you turn on the camcorder and it is connected by an HDMI cable to a TV that supports Anynet+, the TV automatically turns on. If you do not want to use the Anynet+ function, set the **"Anynet+(HDMI-CEC)"** to **"Off."**
- For details on the Anynet+(HDMI-CEC) function, refer to the user manual of Samsung's Anynet+ supported TV.

# Connecting to a TV

## CONNECTING TO A HIGH DEFINITION TV WITH HDMI

You can view High Definition (HD) quality videos recorded in HD resolution on an HDTV using an HDMI connection. This camcorder supports HDMI output to deliver high-definition video transfer.

- ✓ Check if there is an HDMI input jack on your TV.
- ✓ Use the AC power adaptor to power the camcorder when you attach it to a TV.
- Select **"HDMI TV Out."** ➔ page 86

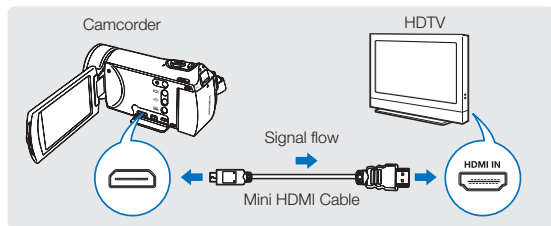

### Using a mini HDMI cable

1. Turn on the camcorder.
  - If you do not turn on the camcorder first, the camcorder may fail to recognise the connected TV.
2. Connect the camcorder to the TV with a Mini HDMI cable.
3. Set the TV's input or source selector to the HDMI input you've attached the camcorder to.
  - Refer to the TV's instruction manual to see how to select the TV's input or source.
4. Select the playback mode on your camcorder, and then start to play back videos or photos. ➔ pages 46,48



### Understanding the HDMI cable

HDMI (High Definition Multimedia Interface) is a compact audio/video interface for transmitting uncompressed digital data.

### What is Anynet+ function?

The Anynet+ function lets you control all devices that support the Anynet + function with the same remote. You can use the Anynet + function on the camcorder if the camcorder is connected by an HDMI cable to a TV that supports Anynet+. For more information, refer to the Anynet+ supported TV's user manual.



- When **"HDMI TV Out"** is set to **"Auto,"** you can play an SD video file in HD format.
- This camcorder comes with the **"TV Connect Guide"** menu function. If you try to connect the camcorder to a TV and don't have your user's manual, you can use the **"TV Connect Guide"** menu function to view connection instructions on the camcorder's screen. ➔ page 87
- You can use only a C to A type Mini HDMI cable with this camcorder.
- The HDMI jack on the camcorder is for output only.
- If you connect an Anynet+ supported TV to the camcorder with an HDMI cable, turning on the camcorder may turn the TV's power on. (an Anynet+ function) If you don't want this to occur, set **"Anynet+(HDMI-CEC)"** to **"Off."** ➔ page 89
- Use only HDMI 1.3 cable when connecting to the HDMI jack of this camcorder. If you use another type of HDMI cable, the screen display may not work.

## CONNECTING TO A REGULAR TV

You can view images recorded with your camcorder on a regular TV that supports standard definition. This camcorder supports the composite output for standard definition video transfer.

- ✔ Use the AC power adaptor to power the camcorder when you connect it to a TV.

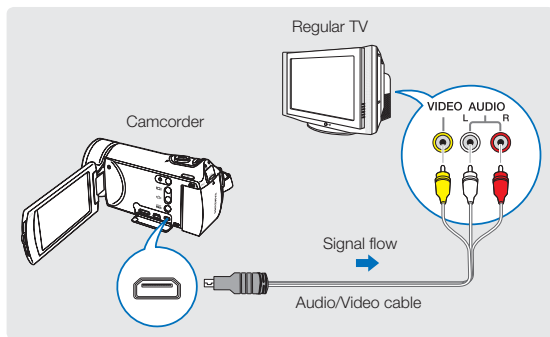

### Connecting an Audio/Video cable for the composite output



1. Connect the camcorder to a TV with an Audio/Video cable.
  - Turn on the camcorder, and then connect an Audio/Video cable. If you do not turn on the camcorder first, the camcorder may fail to recognise the connected TV.
2. Set the TV's input or source selector to the input you've attached the camcorder to.
  - Refer to the TV's instruction manual to see how to select the TV input.
3. Select the playback mode on your camcorder, and then start to play back videos or photos. ➔ pages 46,48



- Make sure you've connected the camcorder to the correct input jacks. The TV screen may not display the right video information if the camcorder is connected incorrectly.
- When connecting to a TV using the Audio/Video cable, match the colour of the cables to the colour of the corresponding jacks.
- Video input may appear green depending on the TV. If this occurs, connect the yellow plug of the Audio/Video cable to the green jack of the TV.
- When the camcorder is connected to a TV with more than one type of cable, the camcorder outputs video signals in the following order of priority:
  - HDMI ➔ Audio/Video (composite) output
- This camcorder comes with the "TV Connect Guide" menu function. If you try to connect the camcorder to a TV and don't have your user's manual, you can use the "TV Connect Guide" menu function to view connection instructions on the camcorder's screen. ➔ page 87
- If your TV has one audio jack (mono input), connect the yellow plug of the Audio/Video cable to the video jack, the white plug to the audio jack, and leave the red plug unconnected.
- When you connect the camcorder to a TV using the Audio/Video cable, images recorded in high-definition image quality (1080/50i or 720/50p) are played back in standard definition image quality.

## VIEWING ON A TV SCREEN

Image appearance depends on the TV screen aspect ratio

Recording ratio	Appearance on Wide (16:9) TV	Appearance on 4:3 TV
Images recorded in a 16:9 ratio: <ul style="list-style-type: none"> <li>• Video images</li> <li>• Photo images</li> <li>• Photo capture images</li> </ul>		

-  • Adjust the volume to a moderate level. If the volume is too high, the video may include noise.
- If "TV Display" is set to "Off," the TV screen does not display the camcorder's OSD (On Screen Display) menus. → page 87

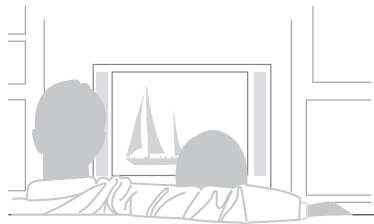

# Dubbing videos

## DUBBING TO A VCR OR DVD/HDD RECORDER

Videos recorded in this camcorder can be dubbed to a VCR or DVD/HDD recorders.



- Videos are dubbed to the other recording device via analogue data transfer (composite connection). Use the supplied Audio/Video cable.
- Use the AC power adaptor to power the camcorder when you dub to a VCR or DVD/HDD recorder.

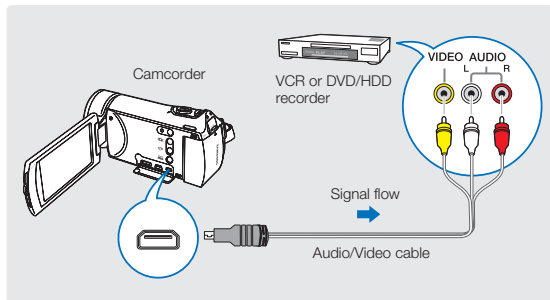

1. Connect your camcorder to the recording device (VCR or DVD/HDD recorder) with the Audio/Video cable.
  - Connect your camcorder to the input jacks of the recording device.
  - If your recording device has an input selector, set it to the correct input mode.
2. Insert the storage device (tape, disc, etc.) into the recording device.
3. Start the playback on your camcorder, and record it on the recording device.
  - Refer to the instruction manuals supplied with your recording device for details.
4. When dubbing is finished, stop the recording device and your camcorder.



- Videos recorded on this camcorder can only be dubbed using the Audio/Video cable in SD (standard definition) image quality, regardless of the recording resolution (HD/SD).
- You cannot dub to a recorder with an HDMI cable.
- To copy a video recorded in HD (high definition) image quality, use the internal software of your camcorder, and copy the video to your computer. ↪ page 97
- Because dubbing is performed via analogue data transfer, the image quality may deteriorate.
- To hide the screen indicators (such as the counter, etc.) on the screen of the connected monitor device set **"TV Display: Off."** ↪ page 87
- To record the date/time, display it on the screen. ↪ page 81

# Printing photos

## DIRECT PRINTING WITH A PICTBRIDGE PRINTER

You can print photos directly by connecting your camcorder to a PictBridge printer (sold separately) using a USB cable.

- ✓ Insert the memory card. ↪ page 34
- Set the appropriate storage media. (HMX-H405 only) ↪ page 33
- Select the Play (▶) tab on the LCD screen to select the Photo play (▶) mode. ↪ page 45

1. Touch the Menu (MENU) → Setting (⚙️) tab → **"USB Connect"** → **"PictBridge."**

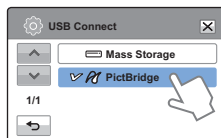

2. Use a USB cable to connect your camcorder to the printer.

3. Turn your printer on.  
• The photo thumbnails appear on the LCD screen.

4. Touch the photos you want to print, and then touch the Print (🖨️) tab.  
• The corresponding message appears.



5. Touch **"Yes."**

### 🔍 To set the number of prints

Touch the decrease (+) / increase (-) tab to set the number of copies to print.

- The number of copies is set.

### To cancel the print setting

Touch the Return (↩️) tab on the LCD screen.

### To stop printing after printing starts

Touch **"Cancel"** on the screen.

- ✋ If the camcorder fails to recognise the printer, remove the USB cable, and then turn off the printer. Set **"USB Connect"** to **"PictBridge,"** and then connect the USB cable again.
- Use the supplied USB cable.

## To set the date/time imprint for Pictbridge printers

1. In the printer mode, touch the Menu (MENU) tab.
  - The print options appear on the screen.
2. Touch "Date/Time."
3. Touch the desired submenu item.
4. To exit the menu, touch the Exit (X) or Return (RETURN) tab.
  - The printer prints the selected date and time on the photos.

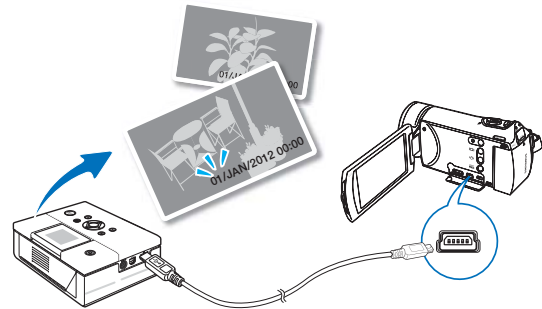
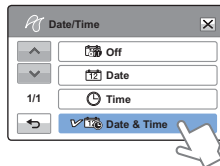
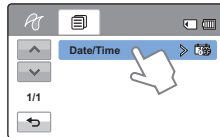
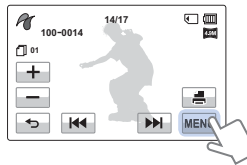

- The date/time imprint option may not be supported by all printers. Check with your printer manufacturer. You cannot setup the "Date/Time" menu if the printer does not support this option.
- PictBridge™ is a registered trademark of CIPA (Camera & Imaging Products Association), an image transfer standard developed by Canon, Fuji, HP, Olympus, Seiko Epson, and Sony.
- Use the AC power adaptor to power your camcorder during PictBridge direct printing. Turning the camcorder off during printing might damage data on the storage media.
- You cannot print video images.
- You cannot print photos recorded on other devices.
- Various printing options are available depending on the printer. Refer to the printer's user manual for details.

# Using with a Windows computer

## WHAT YOU CAN DO WITH A WINDOWS COMPUTER

You can perform the following functions by connecting your camcorder to your Windows computer with a USB cable and using the Intelli-studio editing software built into your camcorder.

### Main functions

- Intelli-studio editing software's main functions.
  - Playing back recorded videos or photos.
  - Editing recorded videos or photos.
  - Uploading the recorded videos and photos to YouTube, Flickr, Facebook, etc.
- You can transfer or copy the files (videos and photos) saved on the storage media into your computer (the mass storage function).

### System requirements

The following requirements must be satisfied to use the internal editing software (Intelli-studio):

Items	Requirement
OS	Microsoft Windows XP SP2, Vista, or Windows 7
CPU	Intel® Core 2 Duo® 1.66 GHz or higher is recommended AMD Athlon™ X2 Dual-Core 2.2 GHz or higher is recommended (Notebook: Intel Core2 Duo 2.2GHz or AMD Athlon X2 Dual-Core 2.6GHz or higher is recommended)
RAM	1GB or higher is recommended
Video Card	NVIDIA GeForce 8500 or higher, ATI Radeon HD 2600 series or higher
Display	1024 x 768, 16-bit colour or higher (1280 x 1024, 32-bit colour recommended)
USB	USB 2.0
Direct X	DirectX 9.0c or higher



- System requirements mentioned above are recommendations. Even on a system that satisfies the requirements, Intelli-studio may not operate optimally.
- On a slower computer than recommended, video playback may skip frames or operate erratically.
- If the version of DirectX on your computer is lower than 9.0c, install DirectX 9.0c or higher.
- We recommend transferring the recorded videos to a PC before playing back or editing the video data.
- To run Intelli-studio, a laptop computer requires better and faster components than a desktop PC.
- Intelli-studio is not Macintosh compatible.
- We cannot guarantee the functionality of third party software. For best performance please use Samsung's built in Intelli-Studio software.

## USING THE Intelli-studio PROGRAM

Intelli-studio is a built-in program that allows you to play back and edit files. You can upload files to web sites, such as YouTube or Flickr. For details, select **"Help"** → **"Help"** on the Intelli-studio screen.

### Step 1. Connecting the USB cable

1 Set **"USB Connect: Mass Storage"** and **"PC Software: On"**.

- These are the default settings.

2 Connect the camcorder to a PC with the USB cable.

- A new file saving window appears along with the Intelli-studio main window. If your camcorder has no new files, the pop-up window for saving new files will not appear.
- Depending on your version of Windows, the Windows removable disk window may also appear.

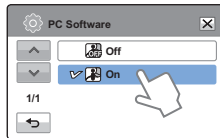

### To disconnect the USB cable

To disconnect the USB cable after completing the file transfer, you must follow these steps:



1. Click the **"Safely Remove Hardware"** icon on the taskbar.
2. Select **"USB Mass Storage Device"**, and then click **"Stop"**.
3. If the **"Stop a Hardware device"** window appears, click **"OK"**.
4. Disconnect the USB cable from the camcorder and PC.

- Use the provided USB cable. (Supplied by Samsung)
- Make sure you insert the USB plug into the USB jack with the plug facing in the correct direction.
- Use the AC power adaptor to power the camcorder when transferring files to your computer.
- When the USB cable is connected, turning the camcorder on or off may cause the PC to malfunction.
- If you disconnect the USB cable from the PC or the camcorder while transferring files, the data transmission will stop and the data may be damaged.
- If you connect the camcorder to a PC via a USB HUB or simultaneously connect the camcorder along with other USB devices, the camcorder may not work properly. If this occurs, remove all USB devices from the PC, and then reconnect the camcorder.
- Intelli-studio may not automatically run. If this occurs, access My Computer or Windows Explorer, open the drive that corresponds to your camcorder, find Intelli-studio, and then run iStudio.exe.

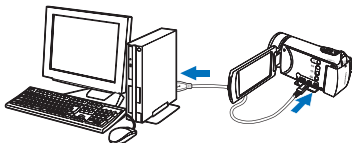

## Step 2. About the Intelli-studio main window

When the Intelli-studio starts up, video and photo thumbnails are displayed in the main window.

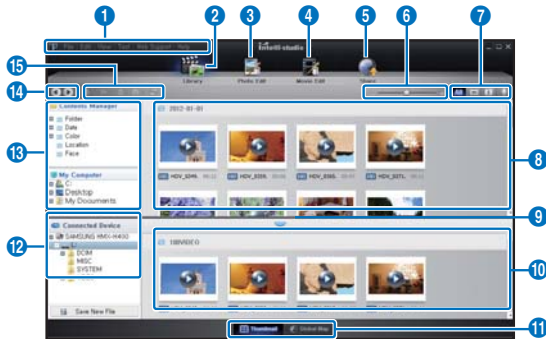

-  If you install Intelli-studio on your PC, the program will launch more quickly. To install the program, select "Tool" → "Install Intelli-studio on PC".
- You can update the latest version of Intelli-studio software by clicking on **Web Support** → **Update Intelli-studio** → **Start Update**.
- The camcorder's built-in Intelli-studio software is intended for home use. It is not for precision or industrial productions. For these applications, we recommend an editing software designed for professional use.



For details, select **Help** → **Help** on the Intelli-studio screen.

No.	Description
1	Menu items
2	Display files in the selected folder.
3	Switch to Photo edit mode.
4	Switch to Video edit mode.
5	Switch to Share mode.
6	Enlarge or reduce the thumbnails in the list.
7	Select a file type.
8	View videos and photos of the selected folder on your computer.
9	Show or hide videos and photos of the connected device.
10	View videos and photos of the selected folder on the device.
11	View files as thumbnails or on a map
12	Browse folders in the connected device.
13	Browse folders stored on your computer
14	Move to the previous or next folder
15	Print files, view files on a map, store files in Contents Manager, register faces, or refresh content manager.

### Step 3. Playing back videos or photos

You can play back the recordings conveniently using the Intelli-studio application.

- 1 With Intelli-studio, click the desired folder to display your recordings.
  - Video or photo thumbnails appear on the screen, depending on the folder you selected.
- 2 Choose the video or photo that you want to play.
  - You can view the file information by moving the mouse over the file.
  - If you click a video thumbnail once, the video plays back inside the thumbnail frame, allowing you to search for a desired scene with ease.
- 3 After you select the video or photo you want, double-click to play back.
  - Playback starts and the controls appear.



-  Intelli-studio supports the following file formats:
- Video formats: MP4 (Video: H.264, Audio: AAC), WMV (WMV 7/8/9)
  - Photo formats: JPG, GIF, BMP, PNG, TIFF

### Step 4. Editing videos or photos

You can edit the videos or photos in various ways with various functions. (Change Size, Fine-Tuning, Image Effect, Insert Frame, etc.) Before editing a video or photo in Intelli-studio, make a backup copy of the video or photo file and store it on your computer for safe-keeping using My Computer or Windows Explorer.

- 1 Choose the videos or photos you want to edit.
- 2 Click "**Movie Edit**" or "**Photo Edit**" according to the selected file on the Intelli-studio browser.
  - The selected file appears in the editing window.
- 3 Edit a video or photo with various edit functions.

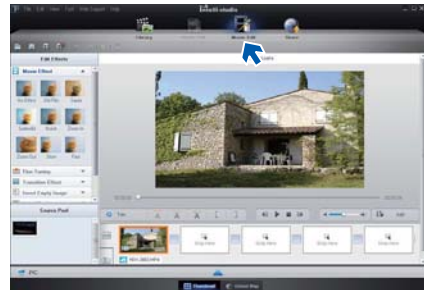

### Step 5. Sharing the videos/photos online

Share your contents with the world by uploading photos and videos directly to a web site with one click.

- 1 Choose the videos or photos you want to share.
- 2 Click **"Share"** on the Intelli-studio browser.
  - The selected file appears in the sharing window.



- 3 Click the web site you would like to upload files to.
  - You can choose "YouTube", "twitter", "Flickr", "Facebook", "Picasa", "Email", or another web site you want to use for your site management.

- 4 Click **"Upload"** to start uploading.
  - A pop-up window appears to open the web browser of the selected site or a pop-up window appears asking for your ID and password.

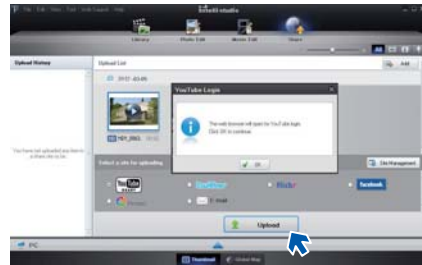

- 5 Enter your ID and the password to access.
    - Access to the web site contents can be limited depending on your web access environment.
-  The recording time and capacity available for uploading videos can be changed depending on each web site's policy.

## USING AS A REMOVABLE STORAGE DEVICE

You can copy video or photo files recorded by the camcorder to a Windows computer by connecting the camcorder to the computer using a USB cable.

### Viewing the contents of storage media

1. Set **"USB Connect"** to **"Mass Storage."** ↪ page 86
2. Set **"PC Software"** to **"Off."** ↪ page 85
3. Insert a memory card. ↪ page 34
4. Connect the camcorder to the PC with the USB cable. ↪ page 97
  - The "Removable Disk" or "Samsung" window appears on the PC's screen after a moment.
  - Select "Open folders to view files using Windows Explorer", and then click "OK."
5. The folders in the storage media appear.
  - Different file types are stored in different folders.
6. Select the desired folder or files to copy, then drag and drop them into the destination folder.
  - The folder or files are copied from the storage media to the PC.

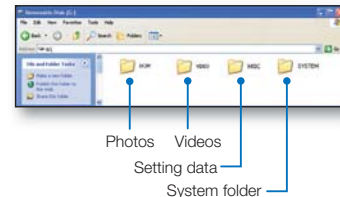
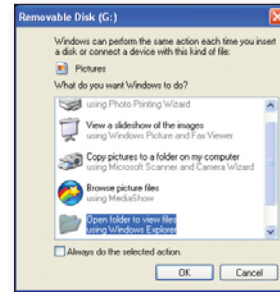

- If the "Removable Disk" window does not appear, confirm the connection (↪ page 97) or perform steps 1 and 4 again. If the removable disk does not appear automatically, open the removable disk folder in My Computer.
- If the connected camcorder's disk drive does not open or the context menu that appears when right clicking your mouse (open or browse) appears broken, your computer may be infected by Autorun virus. Please update your anti-virus software to its latest version and scan your disk drives.
- Depending on the functions of the camcorder, additional folders can be created.

## Structure of folders and files on the storage media

- The folder and file structure for storage media are below.
- File naming follows DCF (Design rule for Camera File System) rules.

### Video file (H.264) ①

- HD-quality videos have an HDV\_####.MP4 name format.
- SD-quality videos have a SDV\_####.MP4 name format.
- The file number used in the file name automatically increases when you create a new video file.
- A new folder is created when the file number has reached 999–1,000.
- The folder names are given in the following order: 100VIDEO, 101VIDEO, etc. The maximum number of folders is 999.
- The camcorder can create a maximum of 9,999 files in a storage media.

### Photo file ②

- As with video files, the file number used in the file name automatically increases when you create a new photo file.
- Photos have a SAM\_####.JPG name format.
- The folder names are given in the following order: 100PHOTO, 101PHOTO, etc.

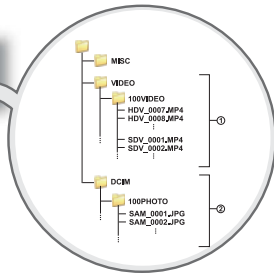
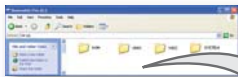

## File format

### Video files

- Video files are compressed in H.264 format. The file extension is “.MP4.”
- Refer to page 53 for the video resolution.

### Photo files

- Photo images are compressed in JPEG (Joint Photographic Experts Group) format. The file extension is “.JPG.”
- Refer to page 54 for the photo resolution.



Do not modify the name of a video file recorded by the camcorder. For proper playback, the camcorder requires that files have their original folder and file names.

# Troubleshooting

Before contacting a Samsung authorised service centre, perform the following simple checks. They may save you the time and expense of an unnecessary call.



## WARNING INDICATORS AND MESSAGES





Problems may occur because of the following reasons. Check the information and take corrective action.

### Battery

Message	Icon	Informs that ...	Action
Low Battery	-	The battery is almost discharged.	<ul style="list-style-type: none"><li>• Replace with a charged battery or connect the AC power adaptor.</li></ul>
Check authenticity of the battery.	-	The battery cannot pass authenticity check.	<ul style="list-style-type: none"><li>• Check whether the battery is authentic. If not, change to an authentic Samsung battery.</li><li>• We recommend you use only genuine Samsung batteries in this camcorder.</li></ul>

### Storage media

Message	Icon	Informs that ...	Action
Internal Memory Full		There is not enough space to record in the internal memory.	<ul style="list-style-type: none"><li>• Delete unnecessary files in the internal memory.</li><li>• Back-up files to your PC or another storage media and delete files.</li><li>• Use a memory card.</li></ul>
Insert card		There is no memory card inserted in the memory card slot.	<ul style="list-style-type: none"><li>• Insert a memory card.</li></ul>
Card Full		There is not enough space to record on the memory card.	<ul style="list-style-type: none"><li>• Delete unnecessary files from the memory card.</li><li>• Back-up files to a PC or another storage media, and then delete unneeded files.</li><li>• Replace the memory card with another card that has enough free space.</li></ul>

Message	Icon	Informs that ...	Action
Card Locked		The write protection tab on an SD or SDHC card has been set to lock.	<ul style="list-style-type: none"> <li>Release the write protection tab.</li> </ul>
Card Error		The memory card has a problem and the camcorder cannot recognise it.	<ul style="list-style-type: none"> <li>Replace the memory card with another card.</li> </ul>
Not Formatted		The memory card is not formatted in this camcorder.	<ul style="list-style-type: none"> <li>Format the memory card using this camcorder.</li> </ul>
Not Supported Format		The memory card may have been formatted by another device and may still have existing images on it.	<ul style="list-style-type: none"> <li>Files cannot be played as the memory card format is not supported by the camcorder.</li> <li>Format the card using the camcorder or replace the card with a card formatted correctly.</li> </ul>
Not Supported Card		The memory card is not supported in this camcorder.	<ul style="list-style-type: none"> <li>Replace the memory card with a recommended card.</li> </ul>
Low Speed Card. Please record at a lower resolution.	-	The memory card is not fast enough to record at this resolution.	<ul style="list-style-type: none"> <li>Record video at a lower resolution and quality.</li> <li>Replace memory card with a faster card.</li> </ul>

## Recording

Message	Icon	Informs that ...	Action
Write Error	-	A problem has occurred while the camcorder was writing data to storage media.	<ul style="list-style-type: none"> <li>Turn the camcorder's power off and on for data recovery.</li> <li>If a file is not recovered, use the camcorder to format the storage media after backing up important files to a PC or another storage media.</li> </ul>
Release the Smart Auto	-	You cannot operate some functions manually when Smart Auto is activated.	<ul style="list-style-type: none"> <li>Release the Smart Auto function.</li> </ul>

### Recording

Message	Icon	Informs that ...	Action
Recovering Data... Don't power off and keep card inside.	-	The file was not created normally.	<ul style="list-style-type: none"> <li>• Wait until data recovery is finished.</li> <li>• Never turn off the power or eject the memory card during recording.</li> </ul>
The number of video files is full. Cannot record video.	-	The number of video files that can be stored is 9,999.	<ul style="list-style-type: none"> <li>• Delete unnecessary files from the storage media.</li> <li>• Back up files to your PC or another storage media and delete unneeded files.</li> <li>• Change to another card which has enough free space.</li> <li>• Set "<b>File No.</b>" to "<b>Reset.</b>"</li> <li>• Format the storage media.</li> </ul>
The number of photo files is full. Cannot take a photo.	-	The number of photo files that can be stored is 9,999.	<ul style="list-style-type: none"> <li>• Delete unnecessary files on the storage media.</li> <li>• Back up files to your PC or another storage media and delete unneeded files.</li> <li>• Change to another card which has enough free space.</li> <li>• Set "<b>File No.</b>" to "<b>Reset.</b>"</li> <li>• Format the storage media.</li> </ul>
File number is full. Cannot record video.	-	Folder and file number have reached the maximum number and you cannot record.	<ul style="list-style-type: none"> <li>• Set "<b>File No.</b>" to "<b>Reset</b>" and format the storage media. Remember to back up important files before formatting.</li> </ul>
File number is full. Cannot take a photo.	-	Folder and file number have reached the maximum number and you cannot record.	<ul style="list-style-type: none"> <li>• Set "<b>File No.</b>" to "<b>Reset</b>" and format the storage media. Remember to back up important files before formatting.</li> </ul>
Check the lens cover.		Lens cover is closed.	<ul style="list-style-type: none"> <li>• Open the lens cover.</li> </ul>

### Playback

Message	Icon	Informs that ...	Action
Read Error	-	A problem has occurred while the camcorder was reading data from the storage media.	<ul style="list-style-type: none"> <li>Use the camcorder to format the storage media after backing up important files to a PC or another storage device.</li> </ul>
Corrupted file	-	This file cannot be read.	<ul style="list-style-type: none"> <li>Use the camcorder to format the storage media after backing up important files to a PC or another storage device.</li> </ul>

### Editing videos

Message	Icon	Informs that ...	Action
Cannot select different resolution.	-	The files you want to combine have different resolutions.	<ul style="list-style-type: none"> <li>You cannot combine files that have different resolutions.</li> </ul>
Not enough free space in Card.	-	You cannot edit due to insufficient space on memory card.	<ul style="list-style-type: none"> <li>Edit after deleting unnecessary files.</li> </ul>
Select 2 files for combine.	-	Only two files can be combined.	<ul style="list-style-type: none"> <li>Combine two files first, and then combine the resulting file with an additional file. Note that you cannot combine files if the total size of the combined files exceeds 1.8GB.</li> </ul>
Total file size is over than 1.8GB.	-	The files whose total size is likely to exceed 1.8GB cannot be combined.	<ul style="list-style-type: none"> <li>Perform a divide or partial delete function first to delete unnecessary parts of the files, and then perform the combine function.</li> </ul>

### USB

Message	Icon	Informs that ...	Action
Fail Printer Connecting Change 'USB Connect'	-	A problem occurred when connecting the camcorder via USB to a printer.	<ul style="list-style-type: none"> <li>• Check the USB cable.</li> <li>• Try the connection procedure again.</li> <li>• Switch "USB connect" function to "PictBridge."</li> </ul>
Fail USB Connecting Change 'USB Connect'	-	A problem occurred when connecting the camcorder via USB to a PC.	<ul style="list-style-type: none"> <li>• Check the USB cable.</li> <li>• Try the connection procedure again.</li> <li>• Switch "USB connect" function to "Mass Storage."</li> </ul>
Ink Error	-	There is a problem with an ink cartridge.	<ul style="list-style-type: none"> <li>• Check the ink cartridge.</li> <li>• Put a new ink cartridge into the printer.</li> </ul>
Paper Error	-	There is a problem with the paper.	<ul style="list-style-type: none"> <li>• Check the paper in the printer. If there is no paper, insert paper.</li> </ul>
File Error	-	There is a problem with the file.	<ul style="list-style-type: none"> <li>• Your camcorder does not support this file format.</li> <li>• Try another file recorded on your camcorder.</li> </ul>
Printer Error	-	There is a problem with the printer.	<ul style="list-style-type: none"> <li>• Turn the printer's power off and on.</li> <li>• Contact the printer manufacturer's service centre.</li> </ul>
Print Error	-	A problem occurred during printing.	<ul style="list-style-type: none"> <li>• Do not remove the camcorder's power source or eject the memory card during printing.</li> </ul>

### SYMPTOMS AND SOLUTIONS

If these instructions do not solve your problem, contact your nearest Samsung authorised service centre.

#### Power

Symptom	Explanation/Solution
The camcorder does not turn on.	<ul style="list-style-type: none"> <li>The battery may not be installed in your camcorder. Insert the battery into the camcorder.</li> <li>The inserted battery may be discharged. Charge the battery or replace it with a charged one.</li> <li>If you use the AC power adaptor, make sure it is properly connected to a wall outlet.</li> </ul>
The power turns off automatically.	<ul style="list-style-type: none"> <li>Is <b>"Auto Power Off"</b> set to <b>"5 Min"</b>? If no button is pressed for about 5 minutes, the camcorder is automatically turned off (<b>"Auto Power Off"</b>). To disable this option, change the setting of <b>"Auto Power Off"</b> to <b>"Off."</b> ↪ page 84</li> <li>The battery is almost exhausted. Charge the battery or replace it with a charged one.</li> </ul>
Power cannot be turned off.	<ul style="list-style-type: none"> <li>Remove the battery or unplug the AC power adaptor, and connect the power supply to the camcorder again before turning it on.</li> </ul>
The battery discharges quickly.	<ul style="list-style-type: none"> <li>The temperature is too low.</li> <li>The battery is not fully charged. Charge the battery again.</li> <li>The battery has reached the end of its lifespan and cannot be recharged. Use another battery.</li> </ul>

#### Display

Symptom	Explanation/Solution
The TV screen or LCD display has distorted images or has stripes at the top/bottom or on the left/right.	<ul style="list-style-type: none"> <li>This can occur when recording or viewing a 16:9 ratio image on a 4:3 ratio TV, or vice versa. For more details, see the display specification. ↪ page 92</li> </ul>
Unknown image appears on the LCD screen.	<ul style="list-style-type: none"> <li>The camcorder is in Demo mode. If you do not want to see Demo images, change <b>"Demo"</b> to <b>"Off."</b> ↪ page 89</li> </ul>
Unknown indicator appears on the screen.	<ul style="list-style-type: none"> <li>A warning indicator or message appears on the screen. ↪ pages 103~107</li> </ul>
An afterimage remains on the LCD screen.	<ul style="list-style-type: none"> <li>This occurs if you disconnect the AC power adaptor or remove the battery before turning the power off.</li> </ul>
The image on the LCD screen looks dark.	<ul style="list-style-type: none"> <li>Ambient light is too bright.</li> </ul>

### Recording

Symptom	Explanation/Solution
Pressing the Recording start/stop button does not start recording.	<ul style="list-style-type: none"> <li>Press the <b>MODE</b> button to set the record mode. ➔page 29</li> <li>There is not enough free space to record on the storage media.</li> <li>Check if memory card is not inserted or write-protect tab is set to lock.</li> </ul>
The actual recording time is less than the estimated recording time.	<ul style="list-style-type: none"> <li>The estimated recording time may vary depending on content and features used.</li> <li>When you record an object that moves quickly, the actual recording time may be shortened.</li> </ul>
The recording stops automatically.	<ul style="list-style-type: none"> <li>There is no more free space for recording on the storage media. Back up important files on your PC and format the storage media or delete unnecessary files.</li> <li>If you make recordings or delete files frequently, the performance of the storage media deteriorates. If this occurs, format the storage media again.</li> <li>If you use a memory card with a low write speed, the camcorder automatically stops recording videos and displays a message on the LCD screen.</li> </ul>
When recording a subject illuminated by bright light, a vertical line appears.	<ul style="list-style-type: none"> <li>This is not a malfunction.</li> </ul>
When the screen is exposed to direct sunlight during recording, the screen becomes red or black for an instant.	<ul style="list-style-type: none"> <li>This is not a malfunction.</li> </ul>
During recording, the date/time does not display.	<ul style="list-style-type: none"> <li><b>"Date/Time Display"</b> is set to <b>"Off."</b> Set the <b>"Date/Time Display"</b> to On. ➔page 81</li> </ul>
You cannot record a photo image.	<ul style="list-style-type: none"> <li>Set your camcorder to the record mode. ➔page 29</li> <li>Release the lock on the write-protection tab of the memory card if any.</li> <li>The storage media is full. Use a new memory card or format the storage media. ➔page 88 Or remove unnecessary images. ➔page 71</li> </ul>
You don't hear the shutter sound when you record a photo image.	<ul style="list-style-type: none"> <li>Set <b>"Shutter Sound"</b> to <b>"On."</b></li> <li>During dual recording (video and photo), the Shutter Sound is off.</li> <li>When the Mini HDMI cable or Audio/Video cable is connected to the camcorder, the Shutter Sound is not available.</li> </ul>
You don't hear the beep sound.	<ul style="list-style-type: none"> <li>Set <b>"Beep Sound"</b> to <b>"On."</b></li> <li>Beep sound is temporarily off while recording videos.</li> <li>When the Mini HDMI cable or Audio/Video cable is connected to the camcorder, the Beep Sound is not available.</li> </ul>
There is a time difference between the point where you press the Recording start/stop button and the point where the recorded video starts/stops.	<ul style="list-style-type: none"> <li>On your camcorder, there may be a slight time delay between the point where you press the <b>Recording start/stop</b> button and the actual point where the recorded video starts/stops. This is not an error.</li> </ul>
Horizontal stripes appear on the images.	<ul style="list-style-type: none"> <li>This occurs when recording images under a fluorescent lamp, sodium lamp, or mercury lamp. This is not a malfunction.</li> </ul>

### Storage Media

Symptom	Explanation/Solution
Memory card functions do not operate.	<ul style="list-style-type: none"> <li>Insert a memory card into your camcorder properly. ↪page 34</li> <li>If you use a memory card formatted on a computer, format it again directly on your camcorder. ↪page 88</li> </ul>
Image cannot be deleted.	<ul style="list-style-type: none"> <li>Release the lock on the write-protect tab of the memory card (SDHC/SD memory card), if any. ↪page 35</li> <li>You cannot delete a protected image. Release protection of the image using the Protect function. ↪page 72</li> </ul>
You cannot format the memory card.	<ul style="list-style-type: none"> <li>Release the lock on the write-protect tab of the memory card (SDHC/SD memory card), if any. ↪page 35</li> <li>The memory card is not supported on your camcorder or the card has some problems.</li> </ul>
The data file name is not indicated correctly.	<ul style="list-style-type: none"> <li>The file may be corrupted.</li> <li>The file format is not supported by your camcorder.</li> <li>The file name is displayed correctly only if the directory structure complies with the international standard.</li> </ul>

### Adjusting the image during recording

Symptom	Explanation/Solution
Focus does not adjust automatically.	<ul style="list-style-type: none"> <li>Set <b>"Focus"</b> to <b>"Auto."</b> ↪page 59</li> <li>The recording conditions are not suitable for auto focus. Adjust the focus manually. ↪page 59</li> <li>The lens is dusty on the surface. Clean the lens and check the focus.</li> <li>Recording is being made in a dark location. Use a light to brighten the area.</li> </ul>
The image appears too bright, flickers, or changes colour.	<ul style="list-style-type: none"> <li>This may occur when you make a recording under a fluorescent sodium, or mercury lamp. Cancel <b>"tSCENE"</b> to avoid or minimise this phenomenon. ↪page 53</li> </ul>
Image's colour balance is not natural.	<ul style="list-style-type: none"> <li>The white balance is incorrect. Set the proper <b>"White Balance."</b> ↪page 55</li> </ul>
A subject passing quickly through the frame appears distorted	<ul style="list-style-type: none"> <li>This is called the focal plane phenomenon. This is not a malfunction. Because of the way the image device (CMOS sensor) reads out video signals, a subject passing through a frame rapidly may appear to bend, depending on the recording conditions.</li> </ul>

### Playback on your camcorder

Symptom	Explanation/Solution
Playback (play/pause) function does not work.	<ul style="list-style-type: none"> <li>Image files recorded using another device may not play on your camcorder.</li> <li>Check memory card compatibility. ➔page 35</li> </ul>
Photo images stored on a storage media are not displayed in the actual size.	<ul style="list-style-type: none"> <li>Photo images recorded on other devices may not appear in their actual size. This is not an error.</li> </ul>
Playback is interrupted unexpectedly.	<ul style="list-style-type: none"> <li>Check if the AC power adaptor or battery back is properly connected and secure.</li> </ul>

### Playback on other devices (TV, etc.)

Symptom	Explanation/Solution
You cannot view the image on or hear the sound from the connected device.	<ul style="list-style-type: none"> <li>Make sure that the connection cable is connected to the proper jack.</li> </ul>
The image appears distorted on a TV.	<ul style="list-style-type: none"> <li>This phenomenon is caused by connecting to a TV with 4:3 aspect ratio.</li> </ul>
You cannot view the image on or hear the sound from a TV connected using the HDMI cable.	<ul style="list-style-type: none"> <li>The camcorder cannot output Images from the HDMI jack if the material is copyright protected.</li> </ul>

### Connecting/Dubbing with other devices (Recorder, PC, Printer, etc.)

Symptom	Explanation/Solution
You cannot dub correctly using the HDMI cable.	<ul style="list-style-type: none"> <li>You cannot dub images using the HDMI cable.</li> </ul>
You cannot dub correctly using the Audio/Video cable.	<ul style="list-style-type: none"> <li>The Audio/Video cable is not connected properly. Make sure that the Audio/Video cable is connected to the proper jack, i.e. to the input jack of the device used for dubbing images from your camcorder. ➔page 93</li> </ul>
Your PictBridge printer cannot print photos from your camcorder.	<ul style="list-style-type: none"> <li>Your printer may not print images edited on a computer or recorded using other devices. This is not an error.</li> </ul>

### Connecting to a computer

Symptom	Explanation/Solution
Your computer does not recognise your camcorder.	<ul style="list-style-type: none"> <li>• Disconnect the USB cable from the computer and camcorder, restart the computer, and then connect the USB cable again correctly.</li> </ul>
Cannot play a video file properly on a PC.	<ul style="list-style-type: none"> <li>• We cannot guarantee the functionality of third party software. For best performance please use Samsung's built in Intelli-Studio software.</li> <li>• You need a video codec to play the file recorded on your camcorder. Install the software provided with your camcorder. ↪ page 96</li> <li>• Make sure you insert the connector in the correct direction, and connect the USB cable to the USB jack on your camcorder firmly.</li> <li>• Disconnect the cable from the computer and camcorder, restart the computer, and then connect the cable again properly.</li> <li>• To play back an HD video file, you need a computer with better specifications. Use a computer with the recommended specifications. ↪ page 96</li> </ul>
Intelli-studio does not function properly.	<ul style="list-style-type: none"> <li>• Exit the Intelli-studio application, and restart the Windows computer.</li> </ul>
Intelli-studio does not start.	<ul style="list-style-type: none"> <li>• Set "<b>PC Software</b>" to "<b>On</b>" in the Settings menu or install Intelli-studio on the computer. ↪ pages 85,97</li> </ul>
Your computer is not playing videos, images, or sound located on your camcorder properly.	<ul style="list-style-type: none"> <li>• Video playback or sound may stop temporarily depending on your computer. The video or sound copied to your computer is not affected.</li> <li>• If your camcorder is connected to a computer that does not support Hi-speed USB (USB2.0), the image or sound may not play correctly. Images, video, and sound copied from the camcorder to your computer are not affected.</li> </ul>
The playback screen is paused or distorted.	<ul style="list-style-type: none"> <li>• Check the system requirements to play a video.</li> <li>• Shut down all other applications currently running on the computer.</li> <li>• If you play a video on your camcorder when it is connected to a computer, the video may not play smoothly on the computer, depending on the transfer speed. Please copy the file to your PC, and then play it back.</li> </ul>

### Overall operations

Symptom	Explanation/Solution
The date and time are incorrect.	<ul style="list-style-type: none"> <li>Has the camcorder been left unused for a long period of time? The backup internal rechargeable battery may be discharged. ➔page 23</li> </ul>

### Menu items that cannot be used at the same time

Symptom	Feature is not enabled	Because of the following settings
Two functions cannot be used at the same time.	"tSCENE"	"Aperture: Manual," "Shutter: Manual"
	"Aperture: Manual"	"Shutter: Manual," "tSCENE"
	"Shutter: Manual"	"Aperture: Manual," "tSCENE"
	"Video Resolution," "Video Quality," "Fader"	"Art Time Lapse REC"
	"Photo Resolution"	"Cont. Shot"

- You cannot select greyed menu items in the current recording/playback mode.
- There are some functions you cannot activate simultaneously.  
The list shown above shows examples of unworkable combinations of functions and menu items.
- Menu cannot be used in Smart Auto mode.
- The following functions cannot be used during video recording:  
"Video Resolution," "Video Quality," "Photo Resolution," "Photo Sharpness," "Fader," "Cont.Shot," "Digital Zoom," "Self Timer."
- The following functions are automatically set to Off or Auto mode in the Smart Auto mode:  
"tSCENE," "Shutter," "Digital Effect," "Tele Macro," etc.
- In the Smart Auto mode, your camcorder automatically chooses the appropriate camcorder settings based on a detected type of scene.  
Most settings are automatically adjusted in Smart Auto mode. To set or adjust functions on your own, release the Smart Auto mode first.

# Maintenance & additional information

## MAINTENANCE

The suggestions below will help you fulfill any warranty obligations and allow you to enjoy this product for many years.

### Cautions when storing

- For safekeeping of the camcorder, turn off the camcorder.
  - Remove the battery and AC power adaptor.
  - Remove the memory card.

### Cleaning the camcorder

**Before cleaning, turn off the camcorder and remove the battery and AC power adaptor.**

- **To clean the exterior**
  - Wipe gently with a soft dry cloth. Do not apply excessive force when cleaning. Gently rub the surface.
  - Do not use benzene or thinner to clean the camcorder. The exterior coating could peel off or the case could deteriorate.
- **To clean the LCD screen**
  - Wipe very gently with a soft dry cloth. Be careful not to damage the screen.
- **To clean the lens**
  - Use a blower brush to remove dust, and then wipe the lens gently with a soft cloth. If necessary, wipe gently with lens paper or tissue.
  - Mould may form if the lens is left dirty.
  - If the lens looks dim, turn off the camcorder and leave it off for about 1 hour.

### LCD screen

**To prolong its service life, do not rub the LCD screen with a coarse cloth.**

- **Be aware of the following LCD screen phenomena. They are not malfunctions.**
  - When you use the camcorder, the surface around the LCD screen may heat up.
  - If you leave the power on for a long time, the surface around the LCD screen becomes hot.
  - When using the camcorder in cold conditions, an afterimage may appear on the LCD screen.

- An LCD screen is manufactured using advanced technology which creates screens with pixel failure rates of less than 0.01%. However, a black or bright spot (red, blue, white) may appear in the centre of the LCD screen and up to two spots may appear outside the centre. These spots, which are normally incurred during the manufacturing process, do not affect the recorded images.



**When there is dew condensation, put the camcorder aside for a while before using**

- **What is dew condensation?**

Dew condensation happens when a camcorder is moved to a location where there is a significant temperature difference from the previous location. The dew condenses on the external or internal parts of the camcorder, and on the reflection lens. If there is dew on or in your camcorder, it may cause the camcorder to malfunction or damage the camcorder when you turn the power on.
- **Exactly when does dew condensation occur?**

When you move the camera to a location with a higher temperature than the previous location, or when you move it to a hot area suddenly. Examples:

  - You record outside in cold weather during the winter and then move the camera indoors.
  - You record outside in hot weather after being indoors or inside a car where the A/C was running.
- **What can I do?**
  - Turn the power off, detach the battery, and leave the camcorder in a dry area for 1–2 hours before using it.



- Use the camcorder only after dew condensation has completely disappeared.
- Be sure to use the recommended accessories supplied with the camcorder. For service, contact your nearest Samsung authorised service centre.

### USING YOUR CAMCORDER ABROAD

- Each country or region has its own electric and colour systems.
- Before using your camcorder abroad, check the following items.

#### Power sources

The AC adaptor provided lets you power, recharge, and use your camcorder in any country/region that has AC power in the 100 V to 240 V, 50/60 Hz range. You may need a commercially available AC plug adaptor depending on the design of local wall outlets.

#### On TV colour systems

Your camcorder is an **PAL** based camcorder. If you want to view your recordings on a TV or copy them to an external device, it must be an **PAL** based TV or external device and have the appropriate Audio/Video jacks. Otherwise, you may need to use a separate video format transcoder (For example, an PAL to NTSC format converter).



The format transcoder is not provided by Samsung.

#### PAL-compatible countries/regions

Australia, Austria, Belgium, Bulgaria, China, CIS, Czech Republic, Denmark, Egypt, Finland, France, Germany, Greece, Great Britain, Holland, Hong Kong, Hungary, India, Iran, Iraq, Kuwait, Libya, Malaysia, Mauritius, Norway, Romania, Saudi Arabia, Singapore, Slovak Republic, Spain, Sweden, Switzerland, Syria, Thailand, Tunisia, etc.

#### NTSC-compatible countries/regions

Bahamas, Canada, Central America, Japan, Korea, Mexico, Philippines, Taiwan, United States of America, etc.



You can make recordings with your camcorder and view pictures on the LCD screen anywhere in the world.

### GLOSSARY

#### [AF \(Auto Focus\)](#)

A system that automatically focuses the camcorder lens on the subject. Your camcorder uses the contrast to focus automatically.

#### [Aperture](#)

The aperture controls the amount of light that reaches the camcorder's sensor.

#### [Camcorder shake \(Blur\)](#)

If the camcorder is moved while the shutter is open, the entire image may appear blurred. This occurs more often when the shutter speed is slow. Prevent camcorder shake by raising the sensitivity, using a faster shutter speed. Alternately, use a tripod, the DIS or OIS function to stabilise the camcorder.

#### [Composition](#)

Composition in photography means arranging objects in a photo. Usually, abiding by the rule of thirds leads to a good composition.

#### [Complementary Metal-Oxide-Semiconductor \(CMOS\)](#)

CMOS is an image sensor producing images approaching the quality of CCD (charge coupled device) sensors. It consumes less power, meaning a longer battery life on your camcorder.

#### [Digital zoom](#)

A feature that artificially increases the amount of zoom available with zoom lens (Optical zoom). When using the Digital zoom, the image quality will deteriorate as the magnification increases.

#### [Effective Pixel Count](#)

Unlike the total pixel count, this is the actual number of pixels used to capture an image.

#### [EV \(Exposure Value\)](#)

All the combinations of the camcorder's shutter speed and lens aperture that result in the same exposure.

#### [Exposure](#)

The amount of light allowed to reach the camcorder's sensor. Exposure is controlled by a combination of the shutter speed, the aperture value, and ISO sensitivity.

#### [Focal length](#)

The distance from the middle of the lens to its focal point (in millimeters). Longer focal lengths result in narrower angles of view and the subject is magnified. Shorter focal lengths result in wider angles of view.

#### [F. No \(F-Number\)](#)

The f-number defines the brightness of lens. Smaller number lens has generally brighter image. The f-number is directly proportional to the focal length and inversely proportional to the lens diameter.

\*F.No=focal length/diameter of lens aperture

#### [MPEG-4 AVC/H.264](#)

MPEG-4 AVC/H.264 defines the latest video coding format standardised by the ISO-IEC and the ITU-T, in 2003. Compared with the conventional MPEG-2 format, MPEG-4 AVC/H.264 has more than twice the efficiency. Your camcorder employs MPEG-4 AVC/H.264 to encode high definition videos.

#### [Optical zoom](#)

This is a general zoom which can enlarge images with a lens and does not deteriorate quality of images.

#### [Quality](#)

An expression of the rate of compression used in a digital image. Higher quality images have a lower rate of compression, which usually results in a larger file size.

#### [Resolution](#)

The number of pixels present in a digital image. High resolution images contain more pixels and typically show more detail than low resolution images.

#### [Shutter speed](#)

Shutter speed refers to the amount of time it takes to open and close the shutter, and it is an important factor in the brightness of a photo, as it controls the amount of light which pass through the aperture before it reaches the image sensor. A fast shutter speed allows less time to let light in and the photo becomes darker and more easily freezes subjects in motion.

#### [Tele Macro](#)

This feature allows you to capture close-up images of very small objects. When using the Tele Macro feature, the camcorder can maintain a sharp focus on small objects at a near life-size ratio (1:1).

#### [White balance \(colour balance\)](#)

An adjustment of the intensities of colours (typically the primary colours red, green, and blue), in an image. The goal of adjusting the white balance, or colour balance, is to correctly render the colours in an image.

# Specifications

Model name	HMX-H400BP/HMX-H405BP	
System	Video signal	PAL
	Picture compression format	H.264 (MPEG-4.AVC)
	Audio compression format	AAC (Advanced Audio Coding)
	Image device	1/4" CMOS
	Effective pixels	1.7M
	Total pixels	5M
	Lens	F1.8 ~ F3.8, 30x optical zoom, 45x digital zoom
	Focal length	2.47mm ~ 74.1mm
LCD screen	Size/dot number	3" Wide Touch LCD / 230k
	LCD screen method	TFT LCD
Connectors	Composite output	1Vp-p (75 $\Omega$ terminated)
	HDMI output	C type connector
	Audio output	-7.5 dBs (600 $\Omega$ terminated)
	USB output	mini USB-B type (USB2.0 High Speed)
General	Power source	DC 5 V, Lithium Ion battery pack 3.7 V
	Power source type	Lithium Ion battery pack, Power supply (100 V ~ 240 V) 50/60 Hz
	Power consumption (Recording)	2.5W (LCD on)
	Operating temperature	32 °F ~ 104 °F (0 °C ~ 40 °C)
	Storage temperature	-4 °F ~ 140 °F (-20 °C ~ 60 °C)
	Storage media	Memory card (SD/SDHC) (Not supplied)
	External dimensions (WxHxD)	Approx. 1.95 inches (49.5mm) x 2.23 inches (56.6mm) x 4.71 inches (119.7mm)
	Weight	Approx. 228g (0.50 lb, 8.04 oz) (Except for Lithium Ion battery)
Internal MIC	Omni-directional stereo microphone	

※ The technical specifications and design may be changed without notice.

# contact SAMSUNG world wide

If you have any questions or comments relating to Samsung products, please contact the samsung customer care centre.

Region	Country	Contact Centre ☎	Web Site
North America	CANADA	1-800-SAMSUNG(726-7864)	www.samsung.com
	MEXICO	01-800-SAMSUNG(726-7864)	www.samsung.com
	U.S.A	1-800-SAMSUNG(726-7864)	www.samsung.com
Latin America	ARGENTINE	0800-333-3733	www.samsung.com
	BRAZIL	0800-124-421, 4004-0000	www.samsung.com
	CHILE	800-SAMSUNG(726-7864) From mobile 02-482 82 00	www.samsung.com
	BOLIVIA	800-10-7260	www.samsung.com
	COLOMBIA	01-8000112112	www.samsung.com
	COSTA RICA	0-800-507-7267	www.samsung.com
	DOMINICA	1-800-751-2676	www.samsung.com
	ECUADOR	1-800-10-7267	www.samsung.com
	EL SALVADOR	800-6225	www.samsung.com
	GUATEMALA	1-800-299-0013	www.samsung.com
	HONDURAS	800-27919267	www.samsung.com
	JAMAICA	1-800-234-7267	www.samsung.com
	NICARAGUA	00-1800-5077267	www.samsung.com
	PANAMA	800-7267	www.samsung.com
	PERU	0-800-777-08	www.samsung.com
	PUERTO RICO	1-800-682-3180	www.samsung.com
	TRINIDAD & TOBAGO	1-800-SAMSUNG(726-7864)	www.samsung.com
	VENEZUELA	0-800-100-5303	www.samsung.com
	Europe	ALBANIA	42 27 5755
AUSTRIA		0810 - SAMSUNG (7267864, € 0.07/min)	www.samsung.com
BELGIUM		02-201-24-18	www.samsung.com/be (Dutch) www.samsung.com/be_fr (French)

Region	Country	Contact Centre ☎	Web Site
Europe	BOSNIA	05 133 1999	www.samsung.com
	BULGARIA	07001 33 11	www.samsung.com
	CROATIA	062 SAMSUNG(062 726 7864)	www.samsung.com
	CZECH	800 - SAMSUNG(800-726786)	www.samsung.com
	DENMARK	70 70 19 70	www.samsung.com
	FINLAND	030 - 6227 515	www.samsung.com
	FRANCE	01 48 63 00 00	www.samsung.com
	GERMANY	01805 - SAMSUNG (726-7864 € 0,14/Min)	www.samsung.com
	CYPRUS	8009 4000 only from landline	www.samsung.com
	GREECE	80111-SAMSUNG (80111 726 7864) only from land line (+30) 210 6897691 from mobile and land line	www.samsung.com
	HUNGARY	06-80-SAMSUNG(726-7864)	www.samsung.com
	ITALIA	800-SAMSUNG(726-7864)	www.samsung.com
	KOSOVO	+381 0113216899	www.samsung.com
	LUXEMBURG	261 03 710	www.samsung.com
	MACEDONIA	023 207 777	www.samsung.com
	MONTENEGRO	020 405 888	www.samsung.com
	NETHERLANDS	0900-SAMSUNG (0900-7267864) (€ 0,10/Min)	www.samsung.com
	NORWAY	815-56 480	www.samsung.com
	POLAND	0 801-1SAMSUNG(172-678) +48 22 607-93-33	www.samsung.com
	PORTUGAL	808 20-SAMSUNG (808 20 7267)	www.samsung.com
	RUMANIA	08010 SAMSUNG (08010 726 7864) only from landline (+40) 21 206 01 10 from mobile and land line	www.samsung.com

Region	Country	Contact Centre ☎	Web Site
Europe	SERBIA	0700 Samsung (0700 726 7864)	www.samsung.com
	SLOVAKIA	0800 - SAMSUNG(0800-726 786)	www.samsung.com/sk
	SPAIN	902 - 1 - SAMSUNG (902 172 678)	www.samsung.com
	SWEDEN	0771 726 7864 (SAMSUNG)	www.samsung.com
	Switzerland	0848 - SAMSUNG(7267864, CHF 0.08/min)	www.samsung.com/ch www.samsung.com/ch_fr/ (French)
	U.K	0330 SAMSUNG (7267864)	www.samsung.com
	EIRE	0818 717100	www.samsung.com
	LITHUANIA	8-800-77777	www.samsung.com
	LATVIA	8000-7267	www.samsung.com
	ESTONIA	800-7267	www.samsung.com
CIS	RUSSIA	8-800-555-55-55	www.samsung.com
	GEORGIA	8-800-555-555	www.samsung.com
	ARMENIA	0-800-05-555	www.samsung.com
	AZERBAIJAN	088-55-55-555	www.samsung.com
	KAZAKHSTAN	8-10-800-500-55-500(GSM: 7799)	www.samsung.com
	UZBEKISTAN	8-10-800-500-55-500	www.samsung.com
	KYRGYZSTAN	00-800-500-55-500	www.samsung.com
	TADJIKISTAN	8-10-800-500-55-500	www.samsung.com
	UKRAINE	0-800-502-000	www.samsung.ua www.samsung.com/ua_ru
	BELARUS	810-800-500-55-500	www.samsung.com
	MOLDOVA	00-800-500-55-500	www.samsung.com
	Asia Pacific	AUSTRALIA	1300 362 603
NEW ZEALAND		0800 SAMSUNG (0800 726 786)	www.samsung.com
CHINA		400-810-5858	www.samsung.com
HONG KONG		(852) 3698-4698	www.samsung.com/hk www.samsung.com/hk_en/
INDIA		1800 1100 11, 3030 8282, 1800 3000 8282 1800 266 8282	www.samsung.com
INDONESIA		0800-112-8888, 021-5699-7777	www.samsung.com

Region	Country	Contact Centre ☎	Web Site	
Asia Pacific	JAPAN	0120-327-527	www.samsung.com	
	MALAYSIA	1800-88-9999	www.samsung.com	
	PHILIPPINES	1-800-10-SAMSUNG(726-7864) for PLDT 1-800-3-SAMSUNG(726-7864) for Digitel 1-800-8-SAMSUNG(726-7864) for Globe 02-5805777	www.samsung.com	
	SINGAPORE	1800-SAMSUNG(726-7864)	www.samsung.com	
	THAILAND	1800-29-3232, 02-689-3232	www.samsung.com	
	TAIWAN	0800-329-999 0266-026-066	www.samsung.com	
	VIETNAM	1 800 588 889	www.samsung.com	
	Middle East	U.A.E	800-SAMSUNG (726-7864)	www.samsung.com
		OMAN	800-SAMSUNG(726-7864)	www.samsung.com
		KUWAIT	183-2255	www.samsung.com
BAHRAIN		8000-4726	www.samsung.com	
Egypt		08000-726786	www.samsung.com	
JORDAN		800-22273	www.samsung.com	
IRAN		021-8255	www.samsung.com	
Morocco		080 100 2255	www.samsung.com	
Saudi Arabia		9200-21230	www.samsung.com	
Turkey		444 77 11	www.samsung.com	
Africa	NIGERIA	0800-726-7864	www.samsung.com	
	Ghana	0800-10077 0302-200077	www.samsung.com	
	Cote D' Ivoire	8000 0077	www.samsung.com	
	Senegal	800-00-0077	www.samsung.com	
	Cameroon	7095- 0077	www.samsung.com	
	KENYA	0800 724 000	www.samsung.com	
	UGANDA	0800 300 300	www.samsung.com	
	TANZANIA	0685 88 99 00	www.samsung.com	
SOUTH AFRICA	0860-SAMSUNG(726-7864)	www.samsung.com		



### **Correct disposal of batteries in this product**

---

**(Applicable in the European Union and other European countries with separate battery return systems)**

This marking on the battery, manual or packaging indicates that the batteries in this product should not be disposed of with other household waste at the end of their working life. Where marked, the chemical symbols Hg, Cd or Pb indicate that the battery contains mercury, cadmium or lead above the reference levels in EC Directive 2006/66. If batteries are not properly disposed of, these substances can cause harm to human health or the environment. To protect natural resources and to promote material reuse, please separate batteries from other types of waste and recycle them through your local, free battery return system.

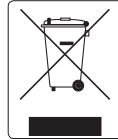

### **Correct Disposal of This Product (Waste Electrical & Electronic Equipment)**

---

**(Applicable in the European Union and other European countries with separate collection systems)**

This marking on the product, accessories or literature indicates that the product and its electronic accessories (e.g. charger, headset, USB cable) should not be disposed of with other household waste at the end of their working life. To prevent possible harm to the environment or human health from uncontrolled waste disposal, please separate these items from other types of waste and recycle them responsibly to promote the sustainable reuse of material resources.

Household users should contact either the retailer where they purchased this product, or their local government office, for details of where and how they can take these items for environmentally safe recycling.

Business users should contact their supplier and check the terms and conditions of the purchase contract. This product and its electronic accessories should not be mixed with other commercial wastes for disposal.



### **RoHS compliant**

Our product complies with "The Restriction Of the use of certain Hazardous Substances in electrical and electronic equipment", and we do not use the 6 hazardous materials- Cadmium(Cd), Lead (Pb), Mercury (Hg), Hexavalent Chromium (Cr +6), Poly Brominated Biphenyls (PBBs), Poly Brominated Diphenyl Ethers(PBDEs)- in our products.