

SENCOR®

SMR 110



OWNER'S MANUAL
USER INSTRUCTIONS
NÁVOD K OBSLUZE
UŽIVATELSKÉ POKYNY
NÁVOD NA OBSLUHU
POUŽIVATEĽSKÉ POKYNY
HASZNÁLATI ÚTMUTATÓ
HASZNÁLATI UTASÍTÁSOK
INSTRUKCJA OBSŁUGI
ZALECENIA DLA UŻYTKOWNIKA

Personal Mobile Radio

Radiostanice

Rádiostanica

Rádióállomás

Radiostacja

EN **CZ** **SK** **HU** **PL**

PIC 1

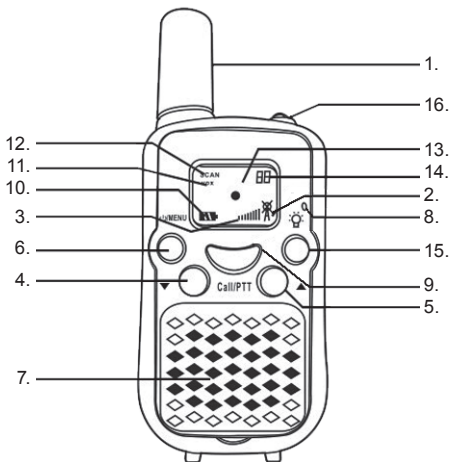

- | | | | |
|---|--------------------------------------|----|---|
| 1 | Antenna | 9 | Call/PTT button (Call)/
(Push-to-talk) |
| 2 | Tx/Rx Icon | 10 | Battery Level |
| 3 | Volume | 11 | Vox |
| 4 | Down Button | 12 | Scanning |
| 5 | Up Button | 13 | Channel//Menu Item |
| 6 | ON/OFF power button /
MENU Button | 14 | CTCSS/Menu option |
| 7 | Speaker | 15 | LED flashlight button |
| 8 | Microphone | 16 | LED flashlight |

PIC 2

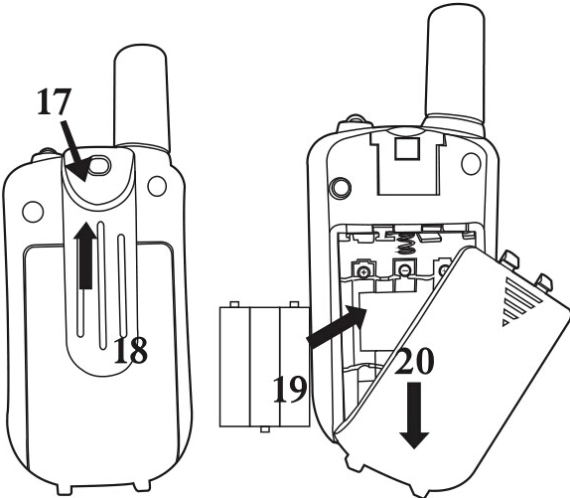

EN ~ Instructions for use

This set includes 2 walkie-talkie units: these are communication devices which operate on mobileradio frequencies. They come with 8 (option) channels as well as a back-lit LCD screen, enabling you to communicate over several kilometres free-of-charge (up to 5 km in open areas)

Note:

Please read these user instructions carefully before using the equipment and retain for future consultation!

Specific recommendations

If you carry any kind of personal medical device, consult a doctor before use.

To avoid the risk of burns, do not use the device if the aerial is damaged in any way.

Do not use the device in a potentially explosive setting (e.g. around petrol pumps, on the lower deck of a boat or around a fuel storage installation or chemical products)

If travelling in a car or by bike, stop before using the device. Switch off the device if on an aeroplane or in a hospital.



Never use the device in close proximity to a radio to avoid interference. Remove the batteries if the device is not in use for an extended period of time. Never mix used and new batteries. Position the transmitter and antenna at least 5 cm from your face. Direct the antenna upwards and speak normally.

Clean the device with a damp cloth. Avoid the use of cleaning agents and solvents.

Do not modify the device in any way. In the event of damage occurring, ensure that the device is checked by a qualified professional.

The device cannot be used to contact the emergency services.

ITEM DESCRIPTION (Pic 01, 02)

1. Antenna
2. RX icon  - Displayed when receiving
TX icon  - Displayed when transmitting
3. Volume level indicator
4. Setting Down button (▼)
5. Setting Up button (▲)
6. ON/OFF power button/MENU (Menu) (⏻)
7. Loud speaker
8. Microphone
9. Call/PTT button (Call)/(Push-to-talk)
10. Battery level indicator
11. VOX indication
12. Scanning indication:
Displayed during scan mode
13. Channel/Menu item indication
14. CTCSS/Menu option -value
15. LED flashlight button
16. LED flashlight
17. Belt attachment clip
18. Belt attachment
19. Batteries (not supplied)
20. Battery compartment

BEFORE USE (PIC 2)

To insert batteries into the devices, first remove the belt attachment: lift the attachment clip (17) and press the belt attachment upwards (18)
Open the battery compartment (20) and insert 3 AAA batteries (19) (not supplied), ensuring that the poles are correctly aligned. Then close the lid.

USING

1. Turning the device on/off:

To turn the device on or off, hold down the ON/OFF power button (6) for 3 seconds a BEEP sound will be played to confirm.

2. Adjusting the volume:

To increase the volume, press the setting Up ▲ button (5); to reduce the volume, press the setting Down ▼ button (4).

Note:

The volumelevel (3) is displayed on the screen.

3. Low Battery Indication

The battery is indicated by number of squares present inside the battery icon on the LCD screen.

Battery Full 

Battery empty 

When the battery is low, the battery icon will flash and a beep will be heard to indicate that the batteries need to be replaced

4. Receiving/transmitting communications:

When the display is on, the devices are in the „Reception“ mode, i.e. they are ready to accept a call or sound transmitted on the activated frequency.

When you short press the Call/PTT (Call) (9) button, the device will switch to the „Transmit“ mode and will send a sound signal to the other device.

For a voice transmission, press and hold the Call/PTT (transmit) (9) button and speak into the microphone (8). Hold down this button until the transmission of your message is complete.

Hold the microphone a minimum of 5 cm from your face.

Note:

- The other device must be set to the same channel and have set the same CTCSS code (see point 7)
- After completing the transmission and releasing the Call/PTT (9) button, the other device will make a sound signal (BEEP) to indicate that this device is ready to transmit.

5. Changing Channels

Press the MENU button (6) once - the number of the current channel will start flashing.

Press the - ▼ button (4) or the- ▲ (5) to change the channel.

Press the Call/PTT -button to (9) confirm and return to stand-by Mode.

Note:

If no button is pressed within 9 seconds during setting, the unit will return to standby.

6. CTCSS(Continuous Tone Coded Squelch System)

License free radio's operating on the 446 MHZ frequency band have 8 available radio channels. If there are many radio's users in your neighbourhood, there is a chance that some of these users are operating on the same radio channel.

To prevent that you receive signals from other users, sub-channels have been integrated.

Two radio's will only be able to communicate with each other when they are operating on the same radio channel and when they have selected exactly the same sub-channel.

When using CTCSS, a low frequency tone (between 67 and 250 Hz) will be transmitted along with the voice signal. There are 38 available tones to choose from. You are free to choose one of these 38 available tones. Due to filtering, these tones will generally not be audible so they will not disturb the communication.

7. CTCSS

Press the MENU-button (6) twice: The current CTCSS code flashes on the display.

Press the ▼ -button (4) or the ▲-button (5) to change to another code.

Press the Call/PTT - button (9) to confirm and return to stand-by mode.

Note:

To turn off CTCSS, select for CTCSS the code „OF“ in the menu. When the entry is confirmed, „OF“ will be displayed.

8. Monitor

You can use the monitor feature to check for weaker signals in the current channel.

To monitor a channel, hold down the ▼(4) button. The monitoring function will be activated after approximately three seconds.

Release the ▼(4). -button to stop channel monitoring.

Note:

During channel monitoring the receiver circuit in the Radio's will not listen to CTCSS codes.

9. VOX Selection

The Radio's is capable of voice activated (VOX) transmission. In VOX mode, the radio will transmit a signal when it is activated by your voice or other sound around you. VOX operation is not recommended if you plan to use your radio in a noisy or windy environment.

Note:

VOX mode will be overridden when you press the „Call/PTT (9“) button.

Press the MENU - button (6) three times, the current VOX setting flashes on the display and the VOX icon is displayed.

Press ▲ -button (5) to set the VOX sensitivity level between 1 and 3 (level 3 is the most sensitive level).

Press ▼ -button (4) until „OF“ appears on the display, to turn VOX OFF.

Press the Call/PTT - button (9) to confirm and return to stand-by mode.

10. Scanning for an active radio channel

Press the Up ▲ button (5) for 3 seconds: The 'Scan' function indicator (12) will appear on the screen and the channel (13) will scan continuously from 1 to 8 (according to current CTCSS subchannel setting only).

Press the Down ▼ button (4) to start scanning channels from 8 to 1
Once an active channel is found, the scanning will stop and you can listen to the transmission.

When the transmission on the found channel stops, the scanning will resume automatically.

Note:

If you press the Call/PTT button (9) while listening to a found channel, the Radio's will go back in stand-by mode on the found channel.

11. Call tones

A call tone alerts others that you want to start talking.

11.1 Setting the Call Tone

The Radio has 10 call tones.

Press the MENU-button (6) four times, "CA" is displayed and the current call tone is flashing.

Press the ▲ -button (4) or the ▼-button (5) to change to another Call Tone.

Press the Call/PTT - button (9) to confirm and return to stand - by Mode.

11.2 Sending a call Tone

Press the Call/PTT - button (9) briefly. The call tone will be transmitted on the set channel.

12. Key-Tone On/Off

When a button is pressed, the unit will beep briefly.

To set the key-tone.

Press the MENU-button (6) five times "to" will be displayed.

Press the ▲ button (5) to turn on or the ▼ button (4) to turn off (OF) the button tones.

Press the Call/PTT - button (9) to confirm your selection and return to the standby mode.

13. Roger Beep On/Off

After the Call/PTT - button is released, the unit will send out a roger beep to confirm that you have stopped talking.

To set the Roger Beep.

Press the MENU-button (6) six times. "ro" will be displayed.

Press the ▲ button (5) to turn on or the ▼ button (4) to turn off (OF) the Roger Beep function.

Press the Call/PTT - button (9) to confirm your selection and return to the standby mode.

14. Display backlight

To activate the LCD display backlight, press any button with the exception of the Call/PTT (9) button or the LED flashlight button (15). The LCD back light will light up for 5 seconds.

15. Battery saving function:

When the device has not been used for 6 seconds, the economy mode is automatically activated. This does not affect the reception of transmissions and the standard mode is automatically reactivated as soon as a signal is detected.

16. Built-in LED flashlight

This radio station is equipped with an additional built-in flashlight function, which can be used for sending light signals or for lighting

17. Technical specifications

Channels	8
Sub-code	CTCSS 38
Frequency	446 MHz
Range	Up to 5 Km (Open field)
Battery	3 AAA
Transmission Power	<= 500 mW ERP
Modulation Type	FM -F3E
Channel spacing	12.5 kHz

18. Channel Frequency Table

Channel	Frequency (MHz)	Channel	Frequency (MHz)
1	446.00625	5	446.05625
2	446.01875	6	446.06875
3	446.03125	7	446.08125
4	446.04375	8	446.09375



Disposal of Old Electrical & Electronic Equipment (Applicable in the European Union and other European countries with separate collection systems) This symbol on the product or on its packaging indicates that this product shall not be treated as household waste. Instead it shall be handed over to the applicable collection point for the recycling of electrical and electronic equipment. By ensuring this product is disposed of correctly, you will help prevent potential negative consequences for the environment and human health, which could otherwise be caused by inappropriate waste handling of this product. The recycling of materials will help to conserve natural resources. For more detailed information about recycling of this product, please contact your local city office or your household waste disposal service.



The CE mark included on the unit, in the manual and on the package means that the product fulfills basic requirements of the R&TTE 1995/EC Regulations and Low Voltage Regulations 73/23/EEC.

The Declaration of Conformity is available on www.sencor.eu.

SENCOR®

EN Warranty conditions

Warranty card is not a part of the device packaging.

This product is warranted for the period of 24 months from the date of purchase to the end-user. Warranty is limited to the following conditions. Warranty is referred only to the customer goods using for common domestic use. The claim for service can be applied either at dealer's shop where the product was bought, or at below mentioned authorized service shops. The end-user is obligated to set up a claim immediately when the defects appeared but only till the end of warranty period. The end user is obligated to cooperate to certify the claiming defects. Only completed and clean (according to hygienic standards) product will be accepted. In case of eligible warranty claim the warranty period will be prolonged by the period from the date of claim application till the date of taking over the product by end-user, or the date the end-user is obligated to take it over. To obtain the service under this warranty, end-user is obligated to certify his claim with duly completed following documents: receipt, certificate of warranty, certificate of installation.

This warranty is void especially if apply as follows:

- Defects which were put on sale.
- Wear-out or damage caused by common use.
- The product was damaged by unprofessional or wrong installation, used in contrary to the applicable instruction manual, used in contrary to legal enactment and common process of use or used for another purpose which has been designed for.
- The product was damaged by uncared-for or insufficient maintenance.
- The product was damaged by dirt, accident of force majeure (natural disaster, fire, and flood).
- Defects on functionality caused by low duality of signal, electromagnetic field interference etc.
- The product was mechanically damaged (e.g. broken button, fall).
- Damage caused by use of unsuitable media, fillings, expendable supplies (batteries) or by unsuitable working conditions (e.g. high temperatures, high humidity, quakes).
- Repair, modification or other failure action to the product by unauthorized person.
- End-user did not prove enough his right to claim (time and place of purchase).
- Data on presented documents differs from data on products.
- Cases when the claiming product cannot be identified according to the presented documents (e.g. the serial number or the warranty seal has been damaged).

Authorized service centers

Visit www.sencor.eu for detailed information about authorized service centers.