

SENCOR®

Let's live!



**DIGITAL AUDIO SYSTEM WITH
BLUETOOTH**

SSS 4001

OPERATING MANUAL

EN



Contents

1. Important safety instructions.....	2
2. Features	5
3. Description	6
3.1. Upper panel	6
3.2. Rear wall.....	7
4. Use.....	8
4.1. Handling and preparation for operation.....	8
4.2. Wiring and operation	8
4.3. Equalizer	10
4.4. Microphone use.....	11
4.5. Using sound enhancement function.....	11
5. Troubleshooting.....	12
6. Technical specifications	13

Declaration

We reserve the right to make corrections, modifications and translations of this manual without prior notice. For this reason, we recommend that you regularly visit our website to get the latest information.

1. Important safety instructions

General safety instructions

- Read these instructions. Follow this manual and the instructions inside.
- Heed all warnings.
- Follow all instructions.
- Use only the attachments and accessories specified by the manufacturer.
- **You must not put an open flame on the device, e.g. a burning candle.**
- Use the device in temperate climate.
- The manufacturer and vendor of the device are in not in any way liable for any direct or indirect damages caused by not following the instructions for installation, setup, operation, maintenance and cleaning of the device mentioned in this manual.
- Protect the device against impacts, falls, blows, shocks, vibration, moisture and dust.
- Before you agree to the use of the device by children, the children must be instructed in an age-appropriate manner about safe use of the device.

Installation, control

- Install the device according to the instructions in the manual.
- Leave free space around the device, it is necessary for proper air circulation. It helps to dissipate the heat generated by the operation of the device. By covering the air vents of the cabinet, you risk overheating and damage of the device. You must ensure that the air circulation will not be prevented by covering the air vents with e.g. newspaper, tablecloth, curtain, etc. Follow the installation instructions in the manual.
- Do not install the device in direct sunlight, or close to heat sources, like radiators, heat exchangers, stoves or other appliances (including amplifiers) producing heat. High temperatures shorten the life of the electronic components of the device significantly. Do not use and do not leave the device near an open fire.
- **The device must not be exposed to dripping or running water and you must not place upon it objects filled with liquid, e.g. vases.** Protect the device against becoming wet, sprayed on or poured on by any liquid, do not leave or install the device outdoors. Do not use the device outdoors. You risk electric shock or fire by not adhering to these instructions.
- Do not use the device close to water.
- Do not attempt to bypass the safety function of the polarized plug. If the plug cannot be plugged into your socket, refer to an electrician to replace your obsolete socket.
- Before plugging the device into the socket make sure the voltage in your socket corresponds with the voltage on the label of the device or power adapter.

- Make sure the power cord is not stepped on or compressed, especially near the plug and point leading from the device or adapter. The power plug (adapter) is used to disconnect the system and must be easy to access.
- Remember to always unplug the plug (adapter) from the socket before unplugging the power cord.
- Disconnect the power cord from the power outlet during thunderstorms, or when not in use for a longer period of time.
- Avoid carrying the device from a cool environment into a warm environment or vice versa, or operating the device in a moist environment. Air moisture may condense in some areas within the device case and may cause the device to become temporarily inoperable. In this case, leave the device in a warm and well-ventilated area and leave for 1–2 hours until the moisture evaporates. The device can be normally used again. Pay attention especially when using it in cold season.
- Under no circumstances are the manufacturer or vendor liable for any direct or indirect damage caused by the failure to observe the instructions for installation, configuration, operation, treatment and cleaning of this device included within this manual.

Repairs and maintenance

- To avoid risks of electric shock or fire, do not remove the device from the case – the case does not contain components that the user could repair or adjust without the necessary equipment and qualification. Refer to a professional service centre if your device requires service.
- In the event of any unusual occurrences during the use of the device, e.g. smelling the characteristic smell of burning insulation or even seeing a smoke, turn the device off immediately, disconnect the power supply and wait with continuing use of the device until you learn the result of its inspection by the service personnel.
- Leave all service to qualified service personnel. Service is necessary when the device is damaged in any way, for example in case of damage to the power cord, spilling liquid on the device, intrusion of foreign objects into the device, when the device is exposed to rain or moisture, if the device does not function in the usual manner or if it fell.
- Before cleaning, transferring and other maintenance disconnect the power plug (adapter) from the power outlet.
- Clean the device with a dry cloth only.
- Do not use gasoline, thinner or other solvents or abrasives, scouring pads, or sponges with scouring pads to clean the device.



WARNING

To prevent risk of fire or electric shock, do not expose the device to rain or moisture.

**WARNING**

The batteries must not be exposed to excessive heat, for example sunlight, fire, etc.

USB connector, notes on the use of the device:

USB memory devices require being connected directly into the device. To prevent a failing or interrupting data transfer, do not use USB extension cable.

Electrostatic discharge can cause the device to not function. In this case, the user must restart the device.

Before using a USB memory device, test that it communicates with the device and its read and write speed.

For maximum reading speed, we recommend to keep the disc space defragmented. Use file system FAT32, single partition, no protection. If the reading/writing of the memory device is not smooth, it can lead to undesirable effects, such as interruption of the image (blocky image) or failure of whole frames, audio malfunctions, and in extreme cases, stopping of the operation. Unexpected behaviour of the memory device or the presence of viruses or other malware, may cause stopping of functioning of the device and need to be restarted.

The USB connector is a standard type and cannot power a USB device with a high power consumption (e.g. hard drives). Use a device with its own power and power them with their own power supply.

The device was designed for maximum compatibility with memory devices. Considering the variety of devices on the market, we cannot guarantee compatibility with every USB device available. Should problems persist, use another memory device.

WARNING: Do not open. There are no parts inside the device replaceable by the user. Leave repairs to a qualified technician.

WARNING: Never use a lubricant for any part of this device.

WARNING: Place the device on a level, firm and stable surface.

WARNING: Do not place this device on any other electrical device.

DECLARATION: Our company reserves the right to review the contents of this manual without prior notice.

2. Features

Thank you for buying our product. The audio system is designed for strong and good quality sound from many sources and their accompanying light effects. It is designed for domestic use at room temperatures without dripping liquids or condensing humidity. Please, read the operating manual to use it properly. Keep the manual for future reference.

- Strong, quadruple digital amplifier for full sound
- Robust construction
- Playing sound via Bluetooth connection
- Line input
- FM tuner with 50 presets
- Slots for memory card and USB
- Microphone inputs
- Graphic equalizer with presets

The content of the package besides the product itself:

This operating manual

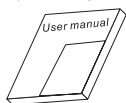

Power cable



Antenna



3. Description

3.1. Upper panel:

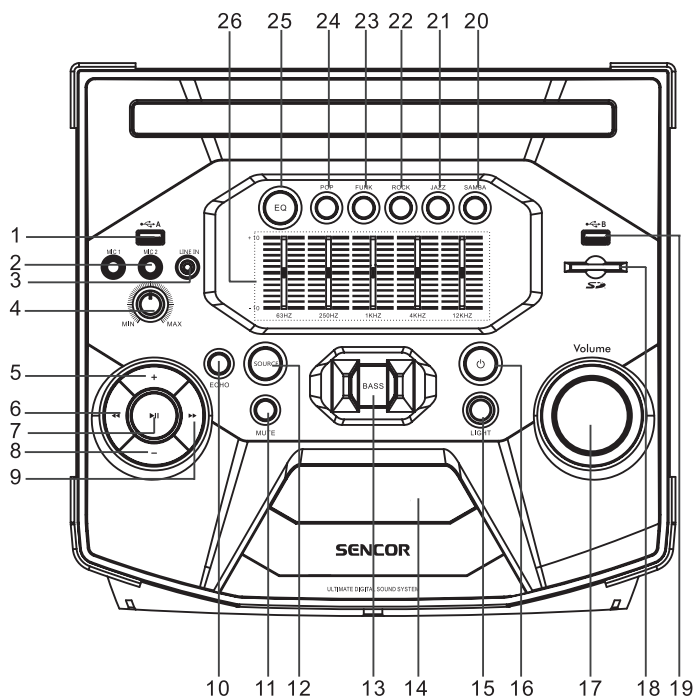

1. Port USB A
2. Microphone inputs 1-2 (jack 6,3 mm)
3. Stereo line input (mini-jack 3,5 mm)
4. Adjusting the microphone volume
5. Button +(+10/Folder/Step up) – press briefly to skip forward by 10 files and press and hold to go to the next folder for playing from the USB or a card, tuning up for the FM tuner.
6. Button Previous (REV) – for playback, for lower FM tuner number of the previously saved preset.
7. Button Play/Pause (Play/Pause) – for media playback, for search of FM tuner bandwidth and saving the found stations, for Bluetooth – press and hold disconnects the currently connected source.
8. Button –(-10/Folder/Step down) – press briefly to skip 10 files back and press and hold go to previous folder to play tracks from USB and card, tuning a step down for the FM tuner.

9. Button Next (FF), for higher number of FM tuner of a previously saved preset.
10. ECHO
11. MUTE (Mute sound) – mutes sound (MUTE on the display) press again to resume sound.
12. SOURCE (Selection of audio source) – switches cyclically between USB A, USB B, SD, LINE, Bluetooth, Radio
13. BASS (Turns on a very strong bass sound)
14. Status display
15. LIGHT (selection of light effects) – press to select from several effects, incl. off, when turning it, it dims the display.
16. On/off switch (On/Off switch)
17. VOLUME (Volume setting knob) – the so-called infinite potentiometer has no zero position. The volume status appears on the display during a change, e.g. "V 12". The range is 40 steps.
18. SD card slot
19. USB B Port
20. Preset EQ SAMBA
21. Preset EQ JAZZ
22. Preset EQ ROCK
23. Preset EQ FUNK
24. Preset EQ POP
25. Button EQ (Manual setting)
26. Setting frequency bands of the equalizer

3.2. Rear wall:

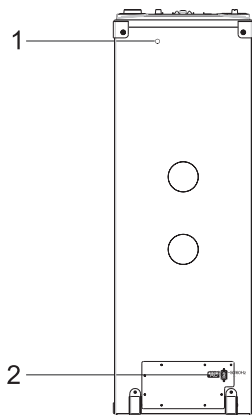

1. FM antenna socket
2. Power cable jack

4. Use

4.1. Handling and preparation for operation

For ease of relocation the audio system is equipped with two wheels at the rear and sizeable grip under the front edge of the top panel.

On the top panel in the back of a groove for the insertion of modern music sources such as your tablet or mobile phone. Before putting them there, make sure that source sits firmly in the groove and can not fall out during operation.

On the rear wall are separate circular outputs of bass reflexes from both woofers. They use the bass energy from the back side of the membrane. It is necessary for their optimum effect that the bass reflex outputs are not covered, clogged or that the audio system is not pressed against the wall. Distance it during the operation at least 10 cm from the wall, but better would be at least 20 cm.

4.2. Wiring and operation

Perform the cable connecting while the audio system is switched into the Standby mode. Make sure that you use good quality cables. Do not subject the input and output connection points to undue mechanical stress. After you perform the connections, press  to turn the audio system on.

4.2.1. LINE IN input

You can plug in the LINE IN input using cable with mini-jack 3.5 mm an external stereo analogue signal source, such as MP3 player, cell phone, etc. Press SOURCE repeatedly until the display shows "LINE".

Tip for volume adjustment

First, set the volume at the source of the signal or on the audio system to minimum, then gradually increase to required level. Avoid unpleasant surprises with very loud sound when the volume is incorrectly set. Keep the volume of all grades under the level that could cause a distortion. Do not leave on the external source of signal even a very low volume, as it could be evaluated by the audio systems as a no signal and the shut-off of the audio system could be activated.

4.2.2. Bluetooth connection

Press repeatedly the button SOURCE until the display shows the message BLUETOOTH. From the speakers issues a gentle tone and the display shows NO BT (no Bluetooth connection is active).

Switch on the Bluetooth on your device (phone, tablet) and select from the found devices SSS 4001 for pairing. If your device would require a pairing code, enter 0000. Once the devices are mutually verified, the Bluetooth connection is set up and the audio system shows CONNECTED on the display and plays a short melody. If you do not deliberately cancel the pairing in your device, the next time the two are on there is no need for performing the pairing again; once both are in the Bluetooth mode, after a while they

automatically connect and the display shows the message and plays a melody. This usually applies, if the last connected device in your device is the audio system or if you gave it a priority. For differences in operation, see the instruction manual of your connected device.

With an active Bluetooth connection to your device that is properly equipped, you can use the audio system for basic controls of your device, using the buttons PLAY / PAUSE, PREV, NEXT to pause and start playing and to skip to the next or previous track.

**NOTICE:**

Long press of the PLAY / PAUSE button in the Bluetooth mode is used to disconnect the currently active Bluetooth connection, if you want to e.g. connect another device.

Notes:

The range of the Bluetooth connection is about 10 m and depends on ambient interference in the wireless range. Therefore keep the distance of your device from the audio system to a minimum.

Volume of the sound source (on your device) in the Bluetooth system is usually independent of other settings. For satisfactory playback, set it to maximum or near maximum and control the playback volume exclusively on the audio system.

4.2.3. Playback from USB and from SD memory card

Both the USB port and the slot for SD card are equipped with automatic selection of the input; after the medium is inserted the audio system selects the appropriate input. It then searches the connected memory and starts playing the first music file. If the memory does not contain any playable files, the display shows "NO SONG". Although the number of tracks is practically unlimited, orientation in larger collections can be difficult, so we recommend using smaller memory sizes, along with a smaller total amount of files and a clear division of the content into folders.

Note:

Keep the openings and contacts of the ports and slots clean. The playback reliability depends on the quality of connection.

**NOTICE ABOUT USB POWER SUPPLY:**

USB ports are designed to cover sufficiently the operating losses of the connected devices and are able to power the connected devices to the level of the standard, i.e. 500 mA. If you want to connect a device with a higher consumption than 500 mA, use an external source for its power supply.

**NOTICE ABOUT COMPATIBILITY:**

Despite the best efforts for compatibility, the usability of all USB and memory devices on the market can not be guaranteed. In case of problems, reformat the memory in your computer to file system FAT / FAT32 and upload the files again. If problems persist, do not continue to use this device and replace it with another. Remember in particular that prolonged use degrades memory devices (e.g. fragmentation of content or wear), and are prone to error due to higher temperatures, respectively temperature and humidity fluctuations. Do not use memory storages, which use special locks, protection, or hidden areas or files, or can be attacked by viruses. If there are irregularities in playback, discontinue the use of such memory, if the system stops altogether and can not be further operated (i.e. freezing), turn off the audio system, unplug it from the wall socket, remove the memory and then turn on the audio system normally.

4.2.4. FM radio

Press repeatedly SOURCE to select the RADIO mode. The display shows the tuned frequency. When you press PLAY/PAUSE, the audio system searches the FM bandwidth and saves the stations with sufficient signal in up to 50 presets. When a station is found, the screen briefly displays the number of the saved preset (some presets may be empty or produce a buzzing sound, etc. It is interference from e.g. non-shielded computer that has the character of FM broadcasting). When the search is finished you can browse among the presets using the buttons FF and REV. You should extend the antenna on the back of the audio system for better reception. If you know the exact frequency of a particular broadcaster, you can tune its reception in steps using the buttons "+" and "-".

4.3. Equalizer

Audio system is equipped with five-band graphic equalizer with the following bands: 63 Hz (soft bass), 250 Hz (hard bass), 1 kHz (middle), 4 kHz (treble for clarity of words and singing), 12 kHz (pitch). Each band can be controlled separately with its rider. In addition to the manual settings you can use any of the 5 modes stored in memory. These modes were originally prepared for various kinds of music and are named typically for various types of music (POP, FUNK, ROCK, JAZZ, SAMBA). Try setting the equalizer according to your own taste and played music. You can obtain setting without additional frequency adjustments (called EQ FLAT) when you set the riders of all bands to middle position (with lock) and active manual selection (EQMAN).

The equalizer is controlled by the main button EQ, which switches between the graphic equalizer (the display shows "EQMAN") and the mode used last.

4.4. Microphone use

For commentary on music or singing Karaoke you can connect to audio system two equivalent mono dynamic microphones with asymmetric 6.3 mm jack connection. Microphone volume is set by special potentiometer under microphone inputs with an indicated minimum. In some cases (e.g. karaoke) it is appropriate to add to the microphone sound repeats/space by switching on the system ECHO.

Note:

Use good quality microphones and especially cables. Weak microphone signals are strongly amplified and any deficiency may manifest itself by increased noise, humming, whistling, crackling, etc.

Tip:

Set the volume of microphones carefully, always from the minimum. You will prevent unwanted feedback, which is very annoying loud noise caused by the amplified sound from the microphone, emitted through the speaker, again amplified, etc. until the loud sound feedback covers the entire sound of the music. To eliminate this phenomenon: reduction of the volume of the microphone input, a partial suppression of the corresponding frequency band by the equalizer, distancing the microphone from the speakers. Also, use of good quality microphones with better directional characteristic. Most susceptible to feedback are microphones with spherical characteristic (omnidirectional), better is octal (bidirectional) characteristic, followed by kidney/cardioid characteristic (cardioid), or special, hypercardioid, gradient.

4.5. Using sound enhancement function

Audio system offers a function to enhance the sound, especially in the bass area, for special sound emphasis, which is important to you. You can turn on the function using the button BASS, the display shows BASS ON, and then turn it off using the same button, the display shows BASS OFF.

Tip:

The function of enhanced sound produces a very loud and powerful sound, try its use in advance.

5. Troubleshooting

In case of problems review possible solutions below before you call service.

Problems	Cause and solution
Cannot turn on	The power cord is not fully inserted in the outlets or is damaged or broken. Insert it correctly in the outlets or replace it with a new, undamaged one. Do not try to use a damaged power cable, it concerns your safety.
No sound from the required source	Playback is stopped or paused, the path of the sound is improperly set. First, check the cables and correct insertion of the connectors. Next, check that the source is playing and then make sure step by step that you have selected the correct audio input and each volume on the audio path is set to an appropriate non-zero level, e.g. in the mid-range.
Distorted sound	High volume. Reduce the overall volume level, or at least one of the frequency band of the equalizer, which produces distortion.
Distorted sound	Inappropriate levels on the sound path. Make sure that the volumes and levels are set properly (typically very large volume of the sound is in the next stage reduced to a minimum) and if the types of inputs and outputs are matched (e.g. a wrong thing is a connection of the line or headphone output into the microphone input).
Buttons do not work, the audio system does not react	Effect of static electricity or a critical error on a connected device. Disconnect the whole system from power, disconnect all connected devices and in a few minutes turn the audio system back on.
Unsatisfactory FM radio reception	Weak or static signal of FM stations. Move the audio system to another place, change the position or the length of the antenna extension. Some reception areas though are not covered by sufficient signal or are very noisy (cellars, industrial parks, dense development, etc.).
Bluetooth connection cannot be established	Incomplete connection initialization. Turn off the Bluetooth on the audio system and the connected system, turn it back on, cancel the pairing and locate it again and reset the pairing (or enter the code 0000).
Bluetooth is falling apart, BT controls do not work	Long distance between receiver and transmitter or radio interference, different functions of the two BT devices. Reduce the distance between the BT devices to an absolute minimum, reduce ambient noise, pair the two devices again.
Only half of the speakers work	The sound signal is not present in both the stereo channels. Make sure that the audio signal is not in only one of the channels (as planned by the author) or the cable is not faulty or that any of the connectors is not incorrectly inserted.

6. Technical specifications

Power	AC ~100-240 V, 50/60 Hz
Power consumption	200 W
Maximum power output	400 W
Frequency range	40 Hz – 16 kHz (+/-3 dB)
FM bandwidth	87,5-108 MHz
Operating temperature	- 10 to 35 °C
Working humidity	5 to 90 %, non-condensing

The above given specifications can change without prior notice.

Manufacturer address: FAST ČR, a.s., Černokostelecká 1621, 251 01 Říčany

The original version is in Czech.

The CE symbol shown on the unit, in the user's manual and on the package indicates the unit meets the basic requirements of guideline R&TTE, 1995/5/EC, Guideline for low voltage 73/23/EEC. The declaration of conformity can be found at www.sencor.cz.

INSTRUCTIONS AND INFORMATION REGARDING THE DISPOSAL OF USED PACKAGING MATERIALS

Dispose of packaging material at a public waste disposal site.



DISPOSAL OF USED ELECTRICAL AND ELECTRONIC APPLIANCES

The meaning of the symbol on the product, its accessory or packaging indicates that this product shall not be treated as household waste. Please, dispose of this product at your applicable collection point for the recycling of electrical & electronic equipment waste. Alternatively in some states of the European Union or other European states you may return your products to your local retailer when buying an equivalent new product.

The correct disposal of this product will help save valuable natural resources and help in preventing the potential negative impact on the environment and human health, which could be caused as a result of improper liquidation of waste. Please ask your local authorities or the nearest waste collection centre for further details. The improper disposal of this type of waste may fall subject to national regulations for fines.

For business entities in the European Union

If you wish to dispose of an electrical or electronic device, request the necessary information from your seller or supplier.

Disposal in other countries outside the European Union

If you wish to dispose of this product, request the necessary information about the correct disposal method from local government departments or from your seller.



This appliance complies with EU rules and regulations regarding electromagnetic and electrical safety.

Changes to the text, design and technical specifications may occur without prior notice and we reserve the right to make these changes.

SENCOR®

EN Warranty conditions

Warranty card is not a part of the device packaging.

This product is warranted for the period of 24 months from the date of purchase to the end-user. Warranty is limited to the following conditions. Warranty is referred only to the customer goods using for common domestic use. The claim for service can be applied either at dealer's shop where the product was bought, or at below mentioned authorized service shops. The end-user is obligated to set up a claim immediately when the defects appeared but only till the end of warranty period. The end user is obligated to cooperate to certify the claiming defects. Only completed and clean (according to hygienic standards) product will be accepted. In case of eligible warranty claim the warranty period will be prolonged by the period from the date of claim application till the date of taking over the product by end-user, or the date the end-user is obligated to take it over. To obtain the service under this warranty, end-user is obligated to certify his claim with duly completed following documents: receipt, certificate of warranty, certificate of installation.

This warranty is void especially if apply as follows:

- Defects which were put on sale.
- Wear-out or damage caused by common use.
- The product was damaged by unprofessional or wrong installation, used in contrary to the applicable instruction manual, used in contrary to legal enactment and common process of use or used for another purpose which has been designed for.
- The product was damaged by uncared-for or insufficient maintenance.
- The product was damaged by dirt, accident of force majeure (natural disaster, fire, and flood).
- Defects on functionality caused by low duality of signal, electromagnetic field interference etc.
- The product was mechanically damaged (e.g. broken button, fall).
- Damage caused by use of unsuitable media, fillings, expendable supplies (batteries) or by unsuitable working conditions (e.g. high temperatures, high humidity, quakes).
- Repair, modification or other failure action to the product by unauthorized person.
- End-user did not prove enough his right to claim (time and place of purchase).
- Data on presented documents differs from data on products.
- Cases when the claiming product cannot be indentified according to the presented documents (e.g. the serial number or the warranty seal has been damaged).

Authorized service centers

Visit www.sencor.eu for detailed information about authorized service centers.

