

SONY[®]



Operation Guide
NW-A605 / A607 / A608

About the Manuals

Included with the player are the Quick Start Guide and this PDF-format Operation Guide. Additionally, after installing CONNECT Player software from the supplied CD-ROM, you can refer to the Help within CONNECT Player.

- The Quick Start Guide explains set up and the basic operations, enabling you to import tracks into a computer, to transfer them to the player, and to play them back.
- This Operation Guide explains advanced features, enabling you to make full use of the player and troubleshoot problems.
- The CONNECT Player Help explains details about using CONNECT Player software (🔗 page 3).



Browsing the Operation Guide

To use the buttons in the Operation Guide

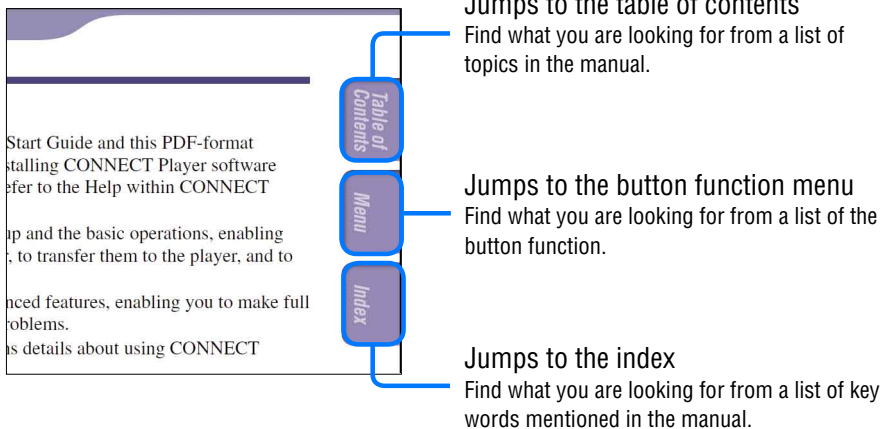
Click the buttons located in the upper right of this manual to jump to “Table of Contents,” “Button Function Menu,” or “Index.”



Hints

- You can jump to the indicated page by clicking a page number in the table of contents, in the button function menu, or in the index.
- You can jump to the indicated page by clicking a page reference indicated by (🔗 page 2), etc.
- To search for a reference page by keyword, click the “Edit” menu, select “Search” of the Adobe Reader to display the navigation frame, type the keyword into the Search text box, and click “Search.”
- You can jump to the previous or next page by clicking the  and  buttons located at bottom of the screen of the Adobe Reader.

Continued ↓

To change the page layout

The buttons at the bottom of the Adobe Reader screen enable you to select how pages are displayed.

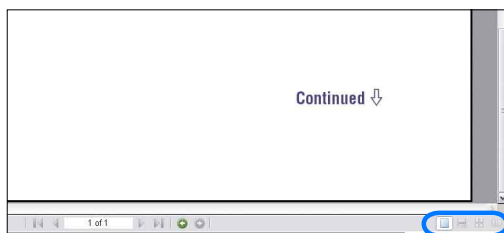

Single Page

Pages are displayed one at a time. When you scroll, the display changes to a previous or succeeding page.

Continuous

Pages are displayed as a continuous roll of pages. When you scroll, the previous and next pages scroll up and down continuously.

Continuous - Facing

Two pages are displayed side by side with each pair part of a continuous roll of pages. When you scroll, the previous and next pairs of pages scroll up and down continuously.

Facing

Two pages are displayed side by side. When you scroll, the display changes to previous or succeeding pairs of pages.

Using CONNECT Player Help

Refer to CONNECT Player Help for details about using CONNECT Player, such as importing tracks to your computer and transferring tracks to the player.

1 Click “Help” – “CONNECT Player Help” while CONNECT Player is running.

Help appears.

Note

- In CONNECT Player Help, the player is referred to as “Device.”

Table of Contents

Supplied Accessories..... 7

Basic Operation – Parts and Controls..... 8

Playing Tracks

Searching for Tracks (Music Library) 12

- Searching for tracks from all tracks
(All Song) 12
- Searching for tracks by artist (Artist) 13
- Searching for tracks by album (Album) 15
- Searching for tracks by genre (Genre) 16
- Searching for tracks by release year
(Release Year) 18
- Searching for tracks from 100 favorite
tracks (Favorite 100) 19
- Searching for tracks by playlist (Playlist) 20
- Searching for tracks from albums recently
transferred (Recent Transfer) 21

Playing Tracks in Random Order

(Intelligent Shuffle) 22

- Playing your 100 favorite tracks in random
order (My Favorite Shuffle) 22
- Playing similar genre tracks to the selected
artist in random order (Artist Link Shuffle) ... 24
- Playing tracks released in the same year in
random order (Time Machine Shuffle) 25
- Playing tracks in random order for a
specified period of time (Sports Shuffle) 26

Changing the Repeat Mode..... 27

- Selecting the repeat mode (Repeat Mode) 28
- Playing tracks repeatedly (Track Repeat) 29
- Playing a specified section repeatedly
(A-B Repeat) 30
- Playing specified sentences repeatedly
(Sentence Repeat) 32

Settings

Setting the Sound Quality

(Digital Sound Preset) 34

Setting the Maximum Speed of the Fast-
forward/Fast-rewind (Cue/Rev) 36

Setting the Volume Using the Preset

Volume Function (Volume Mode) 37

Limiting the Volume (AVLS) 39

Turning Off the Beep Sound (Beep) 40

Saving Power Consumption

(Power Save Mode) 41

Changing the Display Mode 42

Adjusting the Current Time Setting

(Date-Time) 46

Formatting Memory (Format) 48

Changing the USB Connection Setting

(USB Bus Powered) 50

Setting the Date Format

(Date Disp Type) 51

Setting the Time Format

(Time Disp Type) 52

Displaying the Player Information

(Information) 53

FM Tuner

Listening to FM Radio 54

- 1 Switching to the FM tuner 54
- 2 Presetting broadcast stations automatically
(FM Auto Preset) 56
- 3 Selecting broadcast stations 57

Presetting Desired Broadcast Stations

..... 59

To delete preset broadcast stations 59

Setting the Reception (Scan Sens) 60

Continued ↓

Advanced Feature

Recharging the Player	61
Maximizing Battery Life	62
What are Format and Bit Rate?	63
Playing Tracks Without Pauses	64
Playing Audio Files Stored in SonicStage	65
How is Track Information Imported into the Player?	66
Storing Data Other Than Audio Files	67
Upgrading the Player's Firmware	68

Troubleshooting

Troubleshooting	69
Error Messages	75
Uninstalling CONNECT Player	78

Additional Information

Notes on Disposing of the Player	82
Precautions	84
On Copyrights	88
Specifications	89
Index	91

Button Function Menu

You can operate the following functions using the DISP/FUNC, SEARCH/MENU, REPEAT/SOUND button of the player.

Front

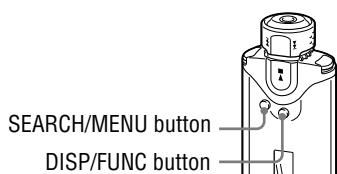

Rear



DISP/FUNC button

Pressing briefly

Switches the display mode 44

Pressing and holding

The following Function menu items appear.

Intelligent Shuffle

- My Favorite Shuffle..... 22
- Artist Link Shuffle..... 24
- Time Machine Shuffle 25
- Sports Shuffle 26

Music Library

- All Song..... 12
- Artist..... 13
- Album..... 15
- Genre..... 16
- Release Year 18
- Favorite 100..... 19
- Playlist..... 20
- Recent Transfer 21

FM (FM Tuner)..... 54

SEARCH/MENU button

Pressing briefly

When using Intelligent Shuffle, the Intelligent Shuffle mode menu appears 22

When using Music Library, the Search menu appears 12

Pressing and holding

The following Setting menu items appear (according to function and playback status).

Various settings (Setting menu)

- Repeat Mode..... 28
- Sound..... 35
- Cue/Rev 36
- FM Auto Preset..... 56
- Scan Sens..... 60
- Volume Mode 37
- AVLS 39
- Beep..... 40
- Power Save Mode..... 41
- Display Screen..... 45
- Date-Time..... 46
- Advanced Menu
 - Format..... 48
 - USB Bus Powered 50
 - Date Disp Type 51
 - Time Disp Type 52
 - Information..... 53

REPEAT/SOUND button

Pressing briefly

Switches the Track Repeat mode 29

Pressing and holding

Switches the Sound quality setting 34

Supplied Accessories

Please check the accessories in the package.

- Headphones (1)

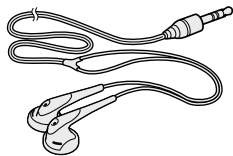

- USB cable (1)

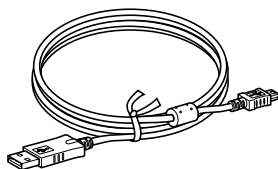

- Headphone extension cord (1)
- Neck strap (China model only) (1)
- Carrying pouch (1)
- Clip (1)
This is used to clip onto your cloths when carrying the player.
- CD-ROM* (1)
- CONNECT Player software
 - Operation Guide (PDF file)
- * Do not attempt to play this CD-ROM in an audio CD player.
- Quick Start Guide (1)

About the serial number

The serial number provided for this player is required for the customer registration. The number is on a label on the rear of the player. Do not remove the label.

Basic Operation – Parts and Controls

Front

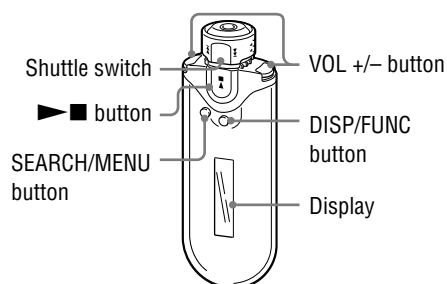

Shuttle switch

Rotate the Shuttle switch in the direction of ►►► or ◀◀◀ to select a track or menu item. You can also skip to the beginning of the track, fast-forward or fast-rewind as follows.

- **Rotating the Shuttle switch to ►►► (or ◀◀◀):** Skips to the beginning of the next (or the current) track.
- **Rotating the Shuttle switch to ►►► (or ◀◀◀), hold it and release at the desired point:** Fast-forwards (or fast-rewinds) the current track. The fast-forward and fast-rewind speed becomes gradually faster.
- **Rotating and holding the Shuttle switch to ►►► (or ◀◀◀) while in stop mode:** Skips to the beginning of the next (or the current) track, and if held longer, continues to skip through the next (or previous) track(s).

Album control mode

You can use Album control mode by setting the Shuttle switch to the ALBUM position.

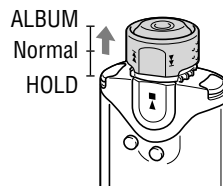

You can skip to the beginning of the album within the Play Range in Album control mode as follows.

- **Rotating the Shuttle switch to ►►► (or ◀◀◀):** Skips to the beginning of the next (or the current) album of the Play Range.
- **Rotating and holding the Shuttle switch to ►►► (or ◀◀◀) while in stop mode:** Skips to the beginning of the next (or the current) album of the Play Range, and if held longer, continues to skip through the next (or previous) album(s).

Continued ↓

HOLD function

You can protect the player against accidental operation by using the HOLD function when carrying it.

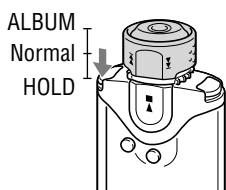



By pushing the Shuttle switch to the HOLD position, all operation buttons are disabled. If you press buttons while the HOLD function is activated, “HOLD” appears in the display.

To release the HOLD function

- Set the Shuttle switch to the center (normal) position.

button

Starts track playback. When starting playback,  appears at the bottom left of the display, and if the  button is pressed again, playback stops.

When a menu appears on the display, use this button to confirm the selected menu item.

SEARCH/MENU button

When using Music Library for track playback (or in stop mode), the Search menu appears for you to select a search method.

When using Intelligent Shuffle for track playback (or in stop mode), the Intelligent Shuffle mode menu appears for you to select a shuffle mode.

Press and hold this button to display the Setting menu.

VOL +/- button

Adjusts the volume.

DISP/FUNC button

Switches the display mode. Press and hold this button to display the Function menu (Intelligent Shuffle/Music Library/FM (FM Tuner)).

Display

For details on the display and icons, see  page 11.

Continued 

Rear

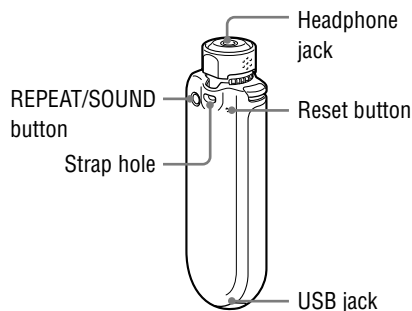

Reset button

Resets the player (☞ page 69).

USB jack

Connects to the small connector of the supplied USB cable.

Continued ↓

REPEAT/SOUND button

Switches the Track Repeat mode. Press and hold this button to change the Sound quality setting.

Strap hole

This is used to attach a neck strap.

Headphone jack

For connecting the headphones.

To use the headphone extension cord

Connect until it clicks into place. If the headphones or headphone extension cord does not connect properly, it may not sound right.

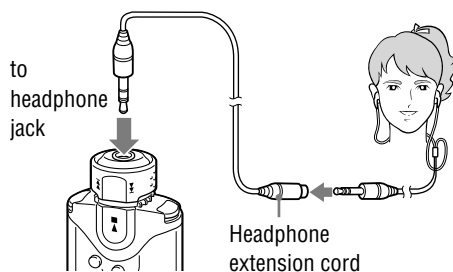

Display

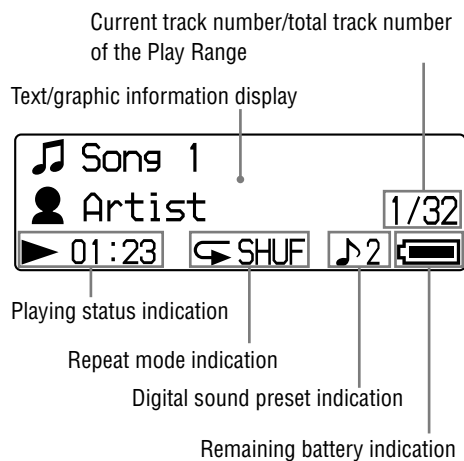

Text/graphic information display

Displays album title, artist name, track name, current date and time, messages and menu.

To switch the display mode, press the DISP/FUNC button. Switch the display to Power Save mode when you do not operate the unit for a while.

Current track number/total track number of the Play Range

Displays the track number currently selected or being played back and the total track number of the current Play Range.

Playing status indication

Displays the current playback mode (▶: playback, ■: stop) and elapsed time.

Repeat mode indication

Displays the current repeat mode if one is set.

Digital sound preset indication

Displays the current digital sound preset if one is set.

Remaining battery indication

Displays the remaining battery power.

Hint

- For information on the FM tuner display, see “FM Tuner” (📖 page 54).

Searching for Tracks (Music Library)

You can search for tracks by “All Song,” “Artist,” “Album,” “Genre,” etc.

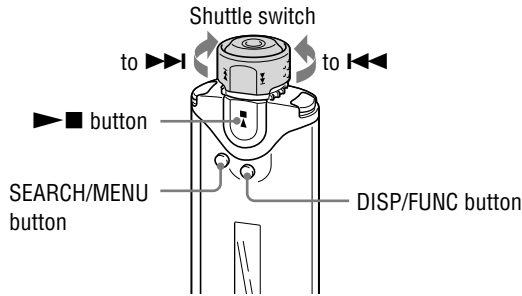

Searching for tracks from all tracks (All Song)

- 1 Press and hold the DISP/FUNC button until the Function menu appears.
- 2 Rotate the Shuttle switch to select “Music Library” and press the >>> button to confirm, and then press the SEARCH/MENU button.
The Search menu screen appears.
- 3 Rotate the Shuttle switch to select “All Song” and press the >>> button to confirm.
All track lists appear in the album order. The list that appears will be the Play Range.
- 4 Rotate the Shuttle switch to select the desired track and press the >>> button to confirm.
The selected track will be played back. If you do not set the repeat mode (🔁 page 27), playback will stop automatically at the end of the Play Range.

💡 Hints

- When you press the SEARCH/MENU button while using Music Library for track playback (or in stop mode), the Search menu appears for you to select a search method (All Song/Artist/Album/Genre/Release Year/Favorite 100/Playlist/RecentTransfer).
- When you press and hold the DISP/FUNC button while using Music Library for track playback (or in stop mode), playback stops and the Function menu appears for you to select a function (Intelligent Shuffle/Music Library/FM (FM Tuner)).

Continued ↓

Searching for tracks by artist (Artist)

- 1 Press and hold the DISP/FUNC button until the Function menu appears.**

- 2 Rotate the Shuttle switch to select “Music Library” and press the  button to confirm, and then press the SEARCH/MENU button.**

The Search menu screen appears.

- 3 Rotate the Shuttle switch to select “Artist” and press the  button to confirm.**

The artist lists appear.

- 4 Rotate the Shuttle switch to select the desired artist and press the  button to confirm.**

The album lists for the selected artist appear.

Hint

- When you select “All Artist” at the top of the artist list and confirm it by pressing the  button, all track lists appear in order of artist name (the tracks of the same artist appear in the album order). In this case, the list that appears will be the Play Range. Proceed to step **6** and start playback.

- 5 Rotate the Shuttle switch to select the desired album and press the  button to confirm.**

The track lists for the selected artist’s album appear. The list that appears will be the Play Range.

Hint

- When you select “All Album” at the top of the album list and confirm it by pressing the  button, all track lists of the artist selected in step **4** appear in the album order. In this case, the list that appears will be the Play Range.

- 6 Rotate the Shuttle switch to select the desired track and press the  button to confirm.**

The selected track will be played back. If you do not set the repeat mode ( page 27), playback will stop automatically at the end of the Play Range.

Continued 

 **Hints**

- When you press the SEARCH/MENU button while using Music Library for track playback (or in stop mode), the Search menu appears for you to select a search method (All Song/Artist/Album/Genre/Release Year/Favorite 100/Playlist/RecentTransfer).
- When you press and hold the DISP/FUNC button while using Music Library for track playback (or in stop mode), playback stops and the Function menu appears for you to select a function (Intelligent Shuffle/Music Library/FM (FM Tuner)).

Continued ↓

Searching for tracks by album (Album)

- 1 Press and hold the DISP/FUNC button until the Function menu appears.**

- 2 Rotate the Shuttle switch to select “Music Library” and press the  button to confirm, and then press the SEARCH/MENU button.**

The Search menu screen appears.

- 3 Rotate the Shuttle switch to select “Album” and press the  button to confirm.**

The album lists appear.

- 4 Rotate the Shuttle switch to select the desired album and press the  button to confirm.**

The track lists for the selected album appear. The list that appears will be the Play Range.

Hint

- When you select “All Album” at the top of the album list and confirm it by pressing the  button, all track lists appear in the album order. In this case, the list that appears will be the Play Range.

- 5 Rotate the Shuttle switch to select the desired track and press the  button to confirm.**

The selected track will be played back. If you do not set the repeat mode ( page 27), playback will stop automatically at the end of the Play Range.

Hints

- When you press the SEARCH/MENU button while using Music Library for track playback (or in stop mode), the Search menu appears for you to select a search method (All Song/Artist/Album/Genre/Release Year/Favorite 100/Playlist/RecentTransfer).
- When you press and hold the DISP/FUNC button while using Music Library for track playback (or in stop mode), playback stops and the Function menu appears for you to select a function (Intelligent Shuffle/Music Library/FM (FM Tuner)).

Continued 

Searching for tracks by genre (Genre)

- 1 Press and hold the DISP/FUNC button until the Function menu appears.**

- 2 Rotate the Shuttle switch to select “Music Library” and press the  button to confirm, and then press the SEARCH/MENU button.**

The Search menu screen appears.

- 3 Rotate the Shuttle switch to select “Genre” and press the  button to confirm.**

The list of genres appears.

- 4 Rotate the Shuttle switch to select the desired genre and press the  button to confirm.**

The album lists for the selected genre appear.

Hint

- When you select “All Genre” at the top of the lists of genres and confirm it by pressing the  button, all track lists appear in order of genre name. In this case, the list that appears will be the Play Range. Proceed to step **6** and start playback.

- 5 Rotate the Shuttle switch to select the desired album and press the  button to confirm.**

The track lists for the selected album appear. The list that appears will be the Play Range.

Hint

- When you select “All Album” at the top of the album list and confirm it by pressing the  button, all track lists for the selected genre in step **4** appear in the album order. In this case, the list that appears will be the Play Range.

- 6 Rotate the Shuttle switch to select the desired track and press the  button to confirm.**

The selected track will be played back. If you do not set the repeat mode ( page 27), playback will stop automatically at the end of the Play Range.

Continued 

 **Hints**

- When you press the SEARCH/MENU button while using Music Library for track playback (or in stop mode), the Search menu appears for you to select a search method (All Song/Artist/Album/Genre/Release Year/Favorite 100/Playlist/RecentTransfer).
- When you press and hold the DISP/FUNC button while using Music Library for track playback (or in stop mode), playback stops and the Function menu appears for you to select a function (Intelligent Shuffle/Music Library/FM (FM Tuner)).

Continued ↓

Searching for tracks by release year (Release Year)

- 1 Press and hold the DISP/FUNC button until the Function menu appears.**

- 2 Rotate the Shuttle switch to select “Music Library” and press the  button to confirm, and then press the SEARCH/MENU button.**

The Search menu screen appears.

- 3 Rotate the Shuttle switch to select “Release Year” and press the  button to confirm.**

The list of release years appears.

- 4 Rotate the Shuttle switch to select the desired release year and press the  button to confirm.**

The track lists for the selected release year appear. The list that appears will be the Play Range.

Hint

- When you select “All Release Year” at the top of the lists of release years and confirm it by pressing the  button, all track lists appear in the release year order. In this case, the list that appears will be the Play Range.

- 5 Rotate the Shuttle switch to select the desired track and press the  button to confirm.**

The selected track will be played back. If you do not set the repeat mode ( page 27), playback will stop automatically at the end of the Play Range.



Hints

- When you press the SEARCH/MENU button while using Music Library for track playback (or in stop mode), the Search menu appears for you to select a search method (All Song/Artist/Album/Genre/Release Year/Favorite 100/Playlist/RecentTransfer).
- When you press and hold the DISP/FUNC button while using Music Library for track playback (or in stop mode), playback stops and the Function menu appears for you to select a function (Intelligent Shuffle/Music Library/FM (FM Tuner)).

Continued ↓

Searching for tracks from 100 favorite tracks (Favorite 100)

You can search for tracks from the 100 most played.

- 1 Press and hold the DISP/FUNC button until the Function menu appears.**
- 2 Rotate the Shuttle switch to select “Music Library” and press the  button to confirm, and then press the SEARCH/MENU button.**
- 3 Rotate the Shuttle switch to select “Favorite 100” and press the  button to confirm.**
- 4 Rotate the Shuttle switch to select the desired track and press the  button to confirm.**

The Search menu screen appears.

The 100 tracks that have been played the most appear.

The selected track will be played back. If you do not set the repeat mode ( page 27), playback will stop automatically at the end of the Play Range.

Hints



- When you press the SEARCH/MENU button while using Music Library for track playback (or in stop mode), the Search menu appears for you to select a search method (All Song/Artist/Album/Genre/Release Year/Favorite 100/Playlist/RecentTransfer).
- When you press and hold the DISP/FUNC button while using Music Library for track playback (or in stop mode), playback stops and the Function menu appears for you to select a function (Intelligent Shuffle/Music Library/FM (FM Tuner)).
- The track play count information for “Favorite 100” is updated every time you connect the player to CONNECT Player.

Continued 

Searching for tracks by playlist (Playlist)

You can play track lists (playlists) created in CONNECT Player.

- 1 Press and hold the DISP/FUNC button until the Function menu appears.**

- 2 Rotate the Shuttle switch to select “Music Library” and press the   button to confirm, and then press the SEARCH/MENU button.**

The Search menu screen appears.

- 3 Rotate the Shuttle switch to select “Playlist” and press the   button to confirm.**

The list of playlists appears.



For details on each playlist type, refer to CONNECT Player Help.

Note

- If no playlists are transferred to the player from CONNECT Player, “NO ITEM” appears. In this case, you cannot search for tracks by the playlist.

- 4 Rotate the Shuttle switch to select a playlist and press the   button to confirm.**

The track lists for the selected playlist appear. The list that appears will be the Play Range.

- 5 Rotate the Shuttle switch to select the desired track and press the   button to confirm.**

The selected track will be played back. If you do not set the repeat mode ( page 27), playback will stop automatically at the end of the Play Range.

Hints

- When you press the SEARCH/MENU button while using Music Library for track playback (or in stop mode), the Search menu appears for you to select a search method (All Song/Artist/Album/Genre/Release Year/Favorite 100/Playlist/RecentTransfer).
- When you press and hold the DISP/FUNC button while using Music Library for track playback (or in stop mode), playback stops and the Function menu appears for you to select a function (Intelligent Shuffle/Music Library/FM (FM Tuner)).

Continued 

Searching for tracks from albums recently transferred (Recent Transfer)

- 1 Press and hold the DISP/FUNC button until the Function menu appears.**

- 2 Rotate the Shuttle switch to select “Music Library” and press the ►■ button to confirm, and then press the SEARCH/MENU button.**

The Search menu screen appears.

- 3 Rotate the Shuttle switch to select “RecentTransfer” and press the ►■ button to confirm.**

The list of recently transferred albums appears.

- 4 Rotate the Shuttle switch to select the desired album and press the ►■ button to confirm.**

The track list for the selected album appears. The list that appears will be the Play Range.

Hint

- When you select “All Recent Transfer” at the top of the album list and confirm it by pressing the ►■ button, all tracks appear in order of transferred album. In this case, the list that appears will be the Play Range.

- 5 Rotate the Shuttle switch to select the desired track and press the ►■ button to confirm.**

The selected track will be played back. If you do not set the repeat mode (🔁 page 27), playback will stop automatically at the end of the Play Range.

Hints

- When you press the SEARCH/MENU button while using Music Library for track playback (or in stop mode), the Search menu appears for you to select a search method (All Song/Artist/Album/Genre/Release Year/Favorite 100/Playlist/RecentTransfer).
- When you press and hold the DISP/FUNC button while using Music Library for track playback (or in stop mode), playback stops and the Function menu appears for you to select a function (Intelligent Shuffle/Music Library/FM (FM Tuner)).

Playing Tracks in Random Order (Intelligent Shuffle)

The player offers 4 different random and repeat play modes (also known as “shuffle play” types).

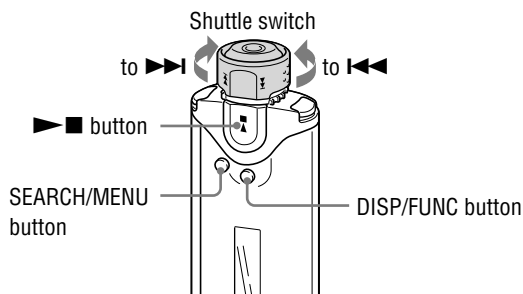

Playing your 100 favorite tracks in random order (My Favorite Shuffle)

The player selects the 100 tracks that have been played the most and plays them in random order repeatedly.

- 1 **Press and hold the DISP/FUNC button until the Function menu appears.**
- 2 **Rotate the Shuttle switch to select “Intelligent Shuffle” and press the ▶■ button to confirm.**
The Intelligent Shuffle mode menu appears.
- 3 **Rotate the Shuttle switch to select “My Favorite Shuffle” and press the ▶■ button to confirm.**
The 100 tracks that have been played the most are shuffled and played back repeatedly.

Continued ↓

 **Hints**

- Pull the Shuttle switch out to the ALBUM position and rotate to select the 100 most frequently played tracks, and they are reshuffled.
- When you press the SEARCH/MENU button while using Intelligent Shuffle for track playback (or in stop mode), the Intelligent Shuffle mode menu appears for you to select a shuffle mode (My Favorite Shuffle/Artist Link Shuffle/Time Machine Shuffle/Sports Shuffle).
- When you press and hold the DISP/FUNC button while using Intelligent Shuffle for track playback (or in stop mode), playback stops and the Function menu appears for you to select a function (Intelligent Shuffle/Music Library/FM (FM Tuner)).
- The track play count information for “My Favorite Shuffle” is updated every time you connect the player to CONNECT Player.
- If the total number of tracks stored on the player is less than 100, all tracks on the player are played in random order.

Continued ↓

Playing similar genre tracks to the selected artist in random order (Artist Link Shuffle)

The player randomly selects an artist, similar genre tracks to the selected artist are searched (Artist Link Shuffle), and plays them in random order repeatedly.

1 Press and hold the DISP/FUNC button until the Function menu appears.

2 Rotate the Shuttle switch to select “Intelligent Shuffle” and press the ►■ button to confirm.

The Intelligent Shuffle mode menu appears.

3 Rotate the Shuttle switch to select “Artist Link Shuffle” and press the ►■ button to confirm.

An artist is randomly selected, similar genre tracks to the selected artist are shuffled, and played back repeatedly.

Hints

- Pull the Shuttle switch out to the ALBUM position and rotate to randomly select an artist, and similar genre tracks to the selected artist are reshuffled.
- When you press the SEARCH/MENU button while using Intelligent Shuffle for track playback (or in stop mode), the Intelligent Shuffle mode menu appears for you to select a shuffle mode (My Favorite Shuffle/Artist Link Shuffle/Time Machine Shuffle/Sports Shuffle).
- When you press and hold the DISP/FUNC button while using Intelligent Shuffle for track playback (or in stop mode), playback stops and the Function menu appears for you to select a function (Intelligent Shuffle/Music Library/FM (FM Tuner)).

Continued ↓

Playing tracks released in the same year in random order (Time Machine Shuffle)

The player randomly selects a release year and plays all tracks in that year in random order repeatedly.

1 Press and hold the DISP/FUNC button until the Function menu appears.

2 Rotate the Shuttle switch to select “Intelligent Shuffle” and press the ►■ button to confirm.

The Intelligent Shuffle mode menu appears.

3 Rotate the Shuttle switch to select “Time Machine Shuffle” and press the ►■ button to confirm.

A release year is randomly selected, the tracks in that year are shuffled, and played back repeatedly.

Hints

- Pull the Shuttle switch out to the ALBUM position and rotate to randomly select a release year, and the tracks in that year are reshuffled.
- When you press the SEARCH/MENU button while using Intelligent Shuffle for track playback (or in stop mode), the Intelligent Shuffle mode menu appears for you to select a shuffle mode (My Favorite Shuffle/Artist Link Shuffle/Time Machine Shuffle/Sports Shuffle).
- When you press and hold the DISP/FUNC button while using Intelligent Shuffle for track playback (or in stop mode), playback stops and the Function menu appears for you to select a function (Intelligent Shuffle/Music Library/FM (FM Tuner)).
- Tracks without a registered release year cannot be played back.

Continued ↓

Playing tracks in random order for a specified period of time (Sports Shuffle)

The player randomly selects tracks from all the stored tracks and plays them in random order repeatedly (between 1 and 99 minutes).

1 Press and hold the DISP/FUNC button until the Function menu appears.

2 Rotate the Shuttle switch to select “Intelligent Shuffle” and press the ►■ button to confirm.

The Intelligent Shuffle mode menu appears.

3 Rotate the Shuttle switch to select “Sports Shuffle” and press the ►■ button to confirm.

The screen to select the time appears.

4 Rotate the Shuttle switch to select the time and press the ►■ button to confirm.

The selected playback time appears, and tracks are randomly selected from all the stored tracks and played back.

Elapsed time appears while playing the track.

Hints

- Pull the Shuttle switch out to the ALBUM position and rotate to randomly select tracks from the stored tracks again, and start playback.
- When you press the SEARCH/MENU button while using Intelligent Shuffle for track playback (or in stop mode), the Intelligent Shuffle mode menu appears for you to select a shuffle mode (My Favorite Shuffle/Artist Link Shuffle/Time Machine Shuffle/Sports Shuffle).
- When you press and hold the DISP/FUNC button while using Intelligent Shuffle for track playback (or in stop mode), playback stops and the Function menu appears for you to select a function (Intelligent Shuffle/Music Library/FM (FM Tuner)).

Changing the Repeat Mode

There are 3 types of repeat mode: Track Repeat, A-B Repeat, and Sentence Repeat.

- **Track Repeat (Track Rep)**

This mode plays back tracks repeatedly in the following 3 ways.

Track Repeat mode	Operation
Repeat	All the tracks in the Play Range (coverage of playback) are played back repeatedly.
Single Repeat	The current track is played back repeatedly.
Shuffle Repeat	All the tracks in the Play Range (coverage of playback) are played back repeatedly in random order.

- **A-B Repeat (A-B Rep)**

This mode plays back a specified section in a track repeatedly.

- **Sentence Repeat (Sentence Rep)**

This mode plays back voice data within a specified section in a track repeatedly.

Continued ↓

Selecting the repeat mode (Repeat Mode)

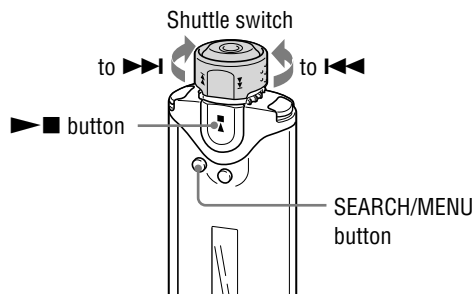

Note

- Only available when using the Music Library function in stop mode.

1 Press and hold the SEARCH/MENU button in stop mode until the Setting menu appears.

2 Rotate the Shuttle switch to select “Repeat Mode>” and press the ►■ button to confirm.

3 Rotate the Shuttle switch to select a desired repeat mode and press the ►■ button to confirm.

You can select one repeat mode from “Track Rep,” “A-B Rep” or “Sentence Rep.”

If you select either “Track Rep” or “A-B Rep,” proceed to step **5**.

If you select “Sentence Rep,” the “Repeat Count” number appears in []. Proceed to step **4**.

4 If “Sentence Rep” is selected in step **3: Rotate the Shuttle switch to select the desired repeat count number and press the ►■ button to confirm.**

You can set the repeat count number from 1-9. The default setting is 2 times.

5 Press the SEARCH/MENU button repeatedly to exit menu mode.

Refer to the following topics for each repeat mode operation.

- Track Rep: “Playing tracks repeatedly (Track Repeat)” (🔗 page 29).
- A-B Rep: “Playing a specified section repeatedly (A-B Repeat)” (🔗 page 30).
- Sentence Rep: “Playing specified sentences repeatedly (Sentence Repeat)” (🔗 page 32).

To cancel the Menu mode

Press the SEARCH/MENU button to return the screen to the previous stage. Press repeatedly to exit menu mode.

Notes

- The display automatically returns to the playback screen if you do not operate any button for 60 seconds.
- When there are no audio files in the built-in flash memory, you cannot set any repeat mode.
- When you connect the player to your computer, the selected repeat mode will be canceled.
- When you change the Play Range, the selected repeat mode will be canceled.

Playing tracks repeatedly (Track Repeat)

The Track Repeat mode is changed by pressing the REPEAT/SOUND button. You can check the current Track Repeat mode with the icon of the display.

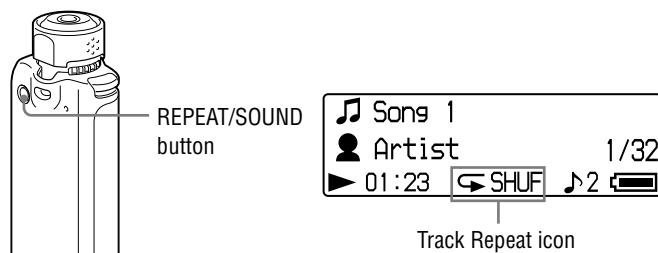

1 Select the Track Repeat mode (Track Rep) (🔍 page 28).

2 Press the REPEAT/SOUND button repeatedly to select the desired repeat mode.

Each press changes the Track Repeat icon as follows:

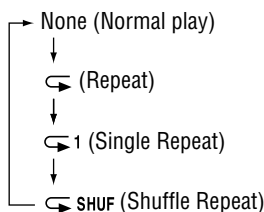

Continued ↓

Playing a specified section repeatedly (A-B Repeat)

While playing a track, you can set the start point (A) and end point (B) for a section you wish to play repeatedly.

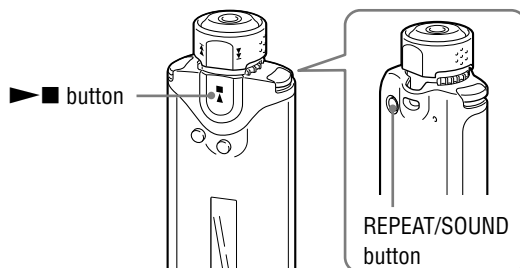

- 1 Select the A-B Repeat mode (A-B Rep) (🔁 page 28).
- 2 Press the ▶ ■ button to start playback.
“A→” blinks.
- 3 Press the REPEAT/SOUND button to set the start point (A) while playing back.
“A→” appears and “B” blinks.
- 4 Press the REPEAT/SOUND button to set the end point (B).
“A→B” appears and the specified section is played back repeatedly.

Notes

- You cannot set A-B Repeat for a section that overlaps two or more tracks.
- If you do not set the end point (B), it is automatically set at the end of the track.
- Rotating the Shuttle switch releases the already set start point (A).
- Switching to the FM tuner releases the already set start point (A).

Continued ↓

To clear the start point (A) and end point (B)

- Press the REPEAT/SOUND button during A-B Repeat playback.
- Press the SEARCH/MENU button during A-B Repeat playback.
- Select the previous or next track by rotating the Shuttle switch during A-B Repeat playback.

(A-B Repeat mode is not canceled.)

To cancel the A-B Repeat mode

Change the Repeat mode in the Setting menu (☞ page 28).

Continued ↓

Playing specified sentences repeatedly (Sentence Repeat)

This function automatically detects voice data between blank spaces (silent section) and repeats the voice data for a set number of counts. This is useful for language-learning material which has no background music.

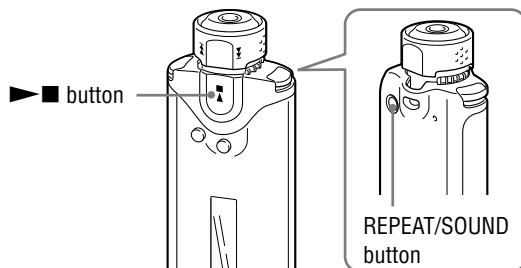

- 1 Select the Sentence Repeat mode (Sentence Rep) (🔍 page 28).
- 2 Press the ▶■ button to start playback.
- 3 Press the REPEAT/SOUND button to place the setting point during playback.

The player detects the speech up to the next blank space (silent section) and repeats the spoken section according to the repeat count you set (🔍 page 28). For example, if you set the repeat count to 3, you will hear each spoken section 4 times - the first time, plus 3 repeats.

Notes

- A spoken or silent section of less than 1 second will not be detected.
- If a spoken section continues up to the very end of a track (with no blank), then that point (end of track) is regarded as the end of that spoken section and it is repeated.
- Switching to the FM tuner during Sentence Repeat releases the setting point.

Continued ↓

To clear the setting point

- Press the REPEAT/SOUND button during Sentence Repeat playback.
- Press the SEARCH/MENU button during Sentence Repeat playback.
- Select the previous or next track by rotating the Shuttle switch during Sentence Repeat playback.

(Sentence Repeat mode is not canceled.)

To cancel the Sentence Repeat mode

Change the Repeat mode in the Setting menu (☞ page 28).

Setting the Sound Quality (Digital Sound Preset)

You can adjust the treble and bass. You can preset 2 settings, which can be selected while the audio player is played.

Selecting the Sound quality setting

Default settings

Sound quality (Indication)	Sound 1 (♪ 1)	Sound 2 (♪ 2)	Sound OFF (None)
Bass	+1	+3	0
Treble	0	0	0

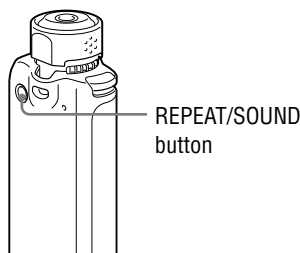

Note

- You cannot select the Sound quality setting while using the FM tuner.

1 Press and hold momentarily the REPEAT/SOUND button.

Each time the button is pressed, the Sound quality setting is changed as follows:

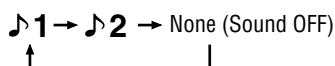

To return to the normal Sound quality

Select "None (Sound OFF)."

Continued ↓

Adjusting the Sound quality (Sound)

You can adjust the bass and treble.

Sound quality	Emphasis level
Bass	-4 to +3
Treble	-4 to +3

You can preset the desired sound quality settings as “Sound 1” and “Sound 2” and select either one while playing music.

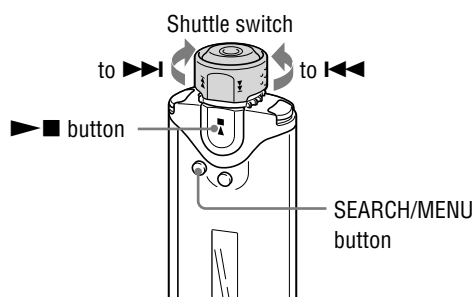

Note

- You cannot adjust the sound quality settings while using the FM tuner.

- 1 Press and hold the SEARCH/MENU button until the Setting menu appears.**
- 2 Rotate the Shuttle switch to select “Sound>” and press the button to confirm.**
- 3 Set the tone for “Sound 1.”**
 - ① Rotate the Shuttle switch to select “Sound 1>” and press the button to confirm.
The value of “Bass” appears in [].
 - ② Rotate the Shuttle switch to adjust the value of “Bass” and press the button to confirm.
The value of “Treble” appears in [].
 - ③ Rotate the Shuttle switch to adjust the value of “Treble” and press the button to confirm.

To adjust the “Sound 2” setting

Select “Sound 2>” in step ③ ①.

To cancel the Menu mode

Press the SEARCH/MENU button to return the screen to the previous stage.
Press repeatedly to exit menu mode.

Setting the Maximum Speed of the Fast-forward/Fast-rewind (Cue/Rev)

You can set the maximum speed of the track fast-forward/fast-rewind to either “Cue/Rev Normal” (normal speed) or “Cue/Rev Rapid” (high speed).

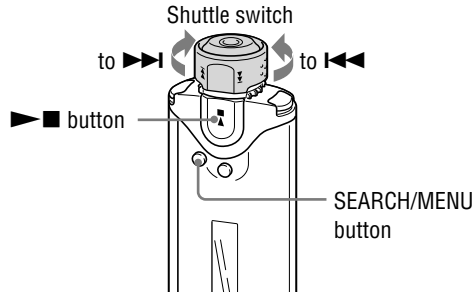

Note

- Only available when using the Music Library or Intelligent Shuffle functions in stop mode.

- 1 Press and hold the **SEARCH/MENU** button until the **Setting** menu appears.
- 2 Rotate the Shuttle switch to select “Cue/Rev>” and press the **▶■** button to confirm.
- 3 Rotate the Shuttle switch to select “Cue/Rev Normal” or “Cue/Rev Rapid” and press the **▶■** button to confirm.

To cancel the Menu mode

Press the **SEARCH/MENU** button to return the screen to the previous stage. Press repeatedly to exit menu mode.

Setting the Volume Using the Preset Volume Function (Volume Mode)

There are 2 modes to adjust the volume level.

Manual Volume:

Press the VOL +/- button to adjust the volume level from 0 to 31.

Preset Volume:

Press the VOL +/- button to set the volume level to any of 3 preset levels: Low, Mid, or High.

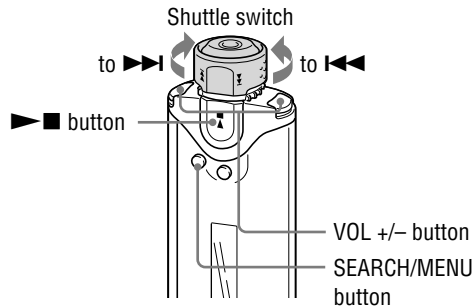

Setting a volume level for preset mode (Preset Volume)

- 1 Press and hold the SEARCH/MENU button until the Setting menu appears.
- 2 Rotate the Shuttle switch to select “Volume Mode>” and press the ▶■ button to confirm.
- 3 Rotate the Shuttle switch to select “Preset Volume>” and press the ▶■ button to confirm.
The value of “Low” appears in [].
- 4 Set the volume levels for the 3 preset levels: Low, Mid, or High.
 - ① Rotate the Shuttle switch to select the volume level for “Low” and press the ▶■ button to confirm.
 - ② Rotate the Shuttle switch to select the volume level for “Mid” and press the ▶■ button to confirm.
 - ③ Rotate the Shuttle switch to select the volume level for “High” and press the ▶■ button to confirm.

Continued ↓



To cancel the Menu mode

Press the SEARCH/MENU button to return the screen to the previous stage.
Press repeatedly to exit menu mode.

Note

- If AVLS (🔊 page 39) is set, the actual volume may be lower than the settings.
Releasing AVLS returns the volume to the preset level.

Switching to manual mode (Manual Volume)

- 1 Press and hold the SEARCH/MENU button until the Setting menu appears.
- 2 Rotate the Shuttle switch to select “Volume Mode>” and press the  button to confirm.
- 3 Rotate the Shuttle switch to select “Manual Volume” and press the  button to confirm.
With this setting, you can adjust the volume level by pressing the VOL +/- button.

To cancel the Menu mode

Press the SEARCH/MENU button to return the screen to the previous stage.
Press repeatedly to exit menu mode.

Limiting the Volume (AVLS)

You can set AVLS (Automatic Volume Limiter System) to limit the maximum volume to prevent auditory disturbance or distraction. With AVLS, you can listen to music at a comfortable volume level.

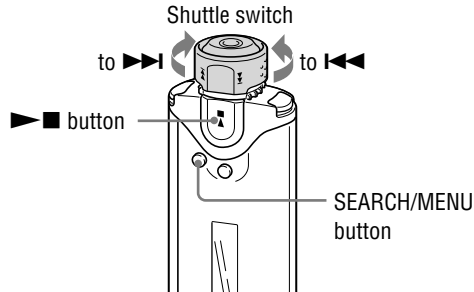

- 1 Press and hold the **SEARCH/MENU** button until the Setting menu appears.
- 2 Rotate the Shuttle switch to select “AVLS>” and press the **▶■** button to confirm.
- 3 Rotate the Shuttle switch to select “AVLS ON” and press the **▶■** button to confirm.
The volume is kept at a moderate level.

To change the setting to off

Select “AVLS OFF” in step 3.

To cancel the Menu mode

Press the **SEARCH/MENU** button to return the screen to the previous stage. Press repeatedly to exit menu mode.

Hint

- “AVLS” appears by pressing the VOL +/- button if AVLS is set to on.

Turning Off the Beep Sound (Beep)

You can turn off the beep sounds of the player.

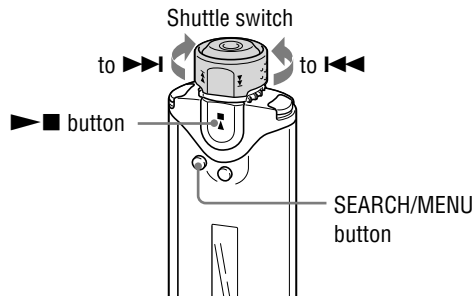

- 1** Press and hold the **SEARCH/MENU** button until the Setting menu appears.
- 2** Rotate the Shuttle switch to select “Beep>” and press the **▶■** button to confirm.
- 3** Rotate the Shuttle switch to select “Beep OFF” and press the **▶■** button to confirm.

To change the setting to on

Select “Beep ON” in step **3**.

To cancel the Menu mode

Press the **SEARCH/MENU** button to return the screen to the previous stage.
Press repeatedly to exit menu mode.

Saving Power Consumption (Power Save Mode)

You can set the player to Power Save mode to turn off the display automatically when you do not operate the unit for a while (15 seconds).

- Save On Normal: Animation appears while playing back music or receiving an FM signal (Power Save display).
- Save On Super: Nothing in the display. This setting uses the least battery consumption.

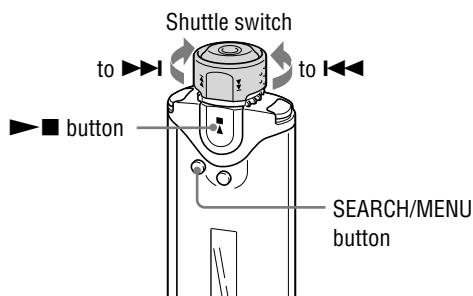

- 1 Press and hold the SEARCH/MENU button until the Setting menu appears.
- 2 Rotate the Shuttle switch to select “Power Save Mode>” and press the ▶ button to confirm.
- 3 Rotate the Shuttle switch to select “Save On Normal” or “Save On Super” and press the ▶ button to confirm.

To set the Power Save mode to off

Select “Save OFF” in Step 3.

To cancel the Menu mode

Press the SEARCH/MENU button to return the screen to the previous stage. Press repeatedly to exit menu mode.

Hint

- The playback/FM tuner screen is always displayed when the Power Save mode is set to “Save OFF.”

Changing the Display Mode

You can view various information in the display while using the Music Library function. To change display mode, press the DISP/FUNC button.

There are 6 types of display, and you can set the desired display in the Setting menu (☞ page 45).

- Property: Displays the current Play Range, the current album number/total album number within the Play Range, the current track number/total track number within the Play Range, the CODEC (compression type), and bit rate.



- Clock1: Displays the current time and date.

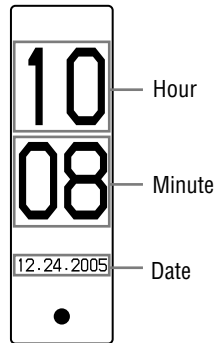

- Clock2: Displays the current time.

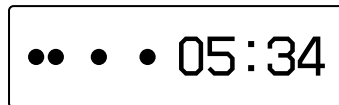

Continued ↓

- Flower: Displays animations.
- Tropical Fish: Displays animations.
- Lapse Time: Displays the current playing status, the current volume level, the elapsed time, and the current track number/total track number of the Play Range.

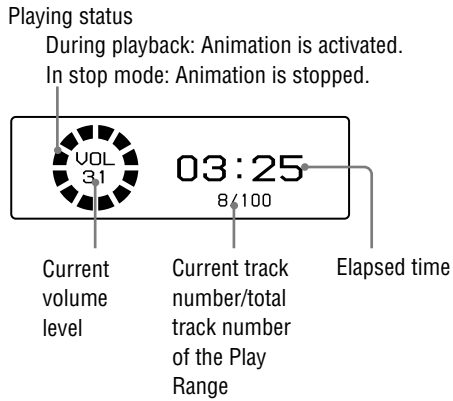

Continued ↓

Changing the display mode

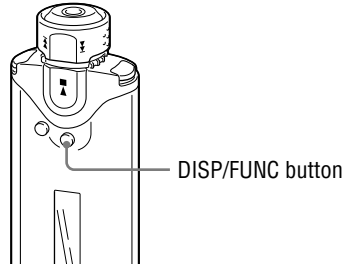

Note

- Only available when using the Music Library function.

1 Press the DISP/FUNC button while using Music Library function.

Each press changes the display mode as follows:

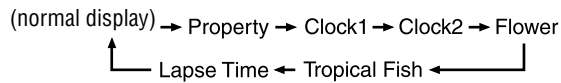

Note

- The diagram above shows the order when all the display types are set to on (has check mark) in the “Display Screen” menu (☞ page 45). Display types set to off (no check mark) will not appear.

Continued ↓

Selecting the display types (Display Screen)

You can select whether or not to use each of the 6 display types: “Property,” “Clock1,” “Clock2,” “Flower,” “Tropical Fish,” and “Lapse Time” by pressing the DISP/FUNC button.

You can only view the screen which is set to on in the “Display Screen” menu.

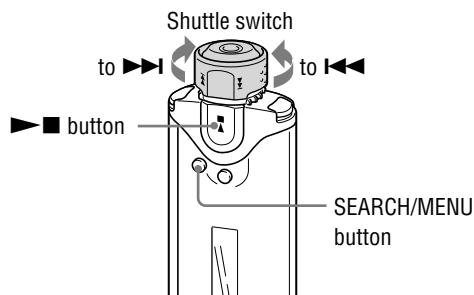

Note

- Only available when using the Music Library function.

- 1 Press and hold the SEARCH/MENU button until the Setting menu appears.**
- 2 Rotate the Shuttle switch to select “Display Screen>” and press the ►■ button to confirm.**
- 3 Set the check marks for “Property,” “Clock1,” “Clock2,” “Flower,” “Tropical Fish,” and “Lapse Time” screen.**
 - ① Rotate the Shuttle switch to select “Property” and press the ►■ button to confirm.
 - ② Rotate the Shuttle switch to select “Clock1” and press the ►■ button to confirm.
 - ③ Rotate the Shuttle switch to select “Clock2” and press the ►■ button to confirm.
 - ④ Rotate the Shuttle switch to select “Flower” and press the ►■ button to confirm.
 - ⑤ Rotate the Shuttle switch to select “Tropical fish” and press the ►■ button to confirm.
 - ⑥ Rotate the Shuttle switch to select “Lapse Time” and press the ►■ button to confirm.

If a check is already marked, the above steps will uncheck it.

To cancel the Menu mode

Press the SEARCH/MENU button to return the screen to the previous stage. Press repeatedly to exit menu mode.

Adjusting the Current Time Setting (Date-Time)

You can set and display the current time.

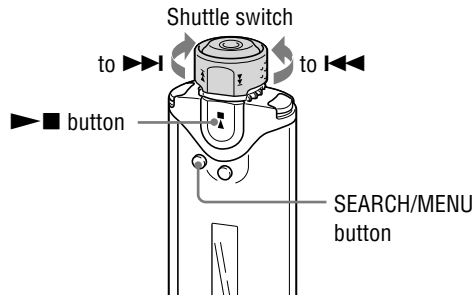

-
- 1** Press and hold the **SEARCH/MENU** button until the Setting menu appears.

 - 2** Rotate the Shuttle switch to select “Date-Time>” and press the **▶■** button to confirm.
The year digit appears in [].

 - 3** Rotate the Shuttle switch to adjust the year setting and press the **▶■** button to confirm.
The month digit appears in [].

 - 4** As you did in step **3**, adjust the settings for month, date, hour, and minute.
After rotating the Shuttle switch to adjust the time and date setting, pressing the **▶■** button to confirm.
-

Continued ↓

To cancel the Menu mode

Press the SEARCH/MENU button to return the screen to the previous stage.
Press repeatedly to exit menu mode.

To display the current time

When using the Music Library function, press the DISP/FUNC button repeatedly until “Clock1” or “Clock2” appears (☞ page 44). Note, however, when both “Clock1” and “Clock2” are set to off in the “Display Screen” menu (☞ page 45), you cannot display the current time by the procedure above. When using the Intelligent Shuffle function or the FM tuner, press the DISP/FUNC button to display the current time.

Hint

- You can select the date format from among “year/month/day,” “day/month/year” and “month/day/year.” Furthermore, you can select either a 12 or 24 hour display. See “Setting the Date Format (Date Disp Type)” (☞ page 51), or “Setting the Time Format (Time Disp Type)” (☞ page 52).

Notes

- If the unit is not used for a long time, your settings for date and time may need to be reset.
- If the current time is not set, the display for the date and time will show “--”.

Formatting Memory (Format)

You can use the player to format the built-in flash memory.

If memory is formatted, all the following data stored in the built-in flash memory will be erased. Be sure to verify the data stored in the memory prior to formatting.

- All music data transferred to the player using the CONNECT Player
- All data stored to the player using Windows Explorer, etc.

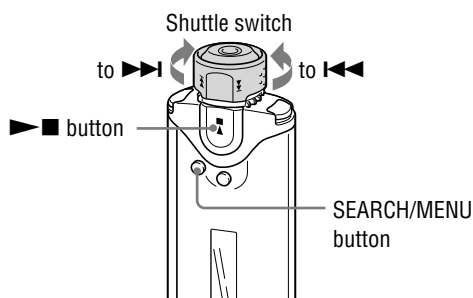

Note

- Only available when using the Music Library function in stop mode.

- 1 Press and hold the **SEARCH/MENU** button in stop mode until the **Setting** menu appears.
- 2 Rotate the **Shuttle switch** to select “**Advanced Menu>**” and press the **▶■** button to confirm.
- 3 Rotate the **Shuttle switch** to select “**Format>**” and press the **▶■** button to confirm.
- 4 Rotate the **Shuttle switch** to select “**OK**” and press the **▶■** button to confirm.

“Formatting...” appears and formatting starts.

When formatting is complete, “Complete” appears.

Continued ↓

To cancel the Menu mode

Press the SEARCH/MENU button to return the screen to the previous stage.
Press repeatedly to exit menu mode.

To cancel formatting

Select “Cancel” and press the  button to confirm in step 4.

Note

- Do not format the built-in flash memory using Windows Explorer. If you format the built-in flash memory, format it using the “Format” menu of the player.

Changing the USB Connection Setting (USB Bus Powered)

Depending on the computer you are using, if the power supply is insufficient, incomplete data transfer may occur from the computer to the player. In this case, setting the USB connection (USB Bus Powered) to “Low-Power 100mA” may improve data transfer.

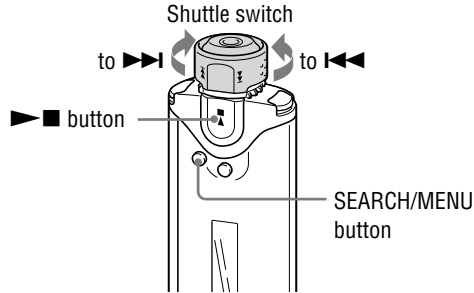

Note

- Only available when using the Music Library function in stop mode.

- 1 Press and hold the **SEARCH/MENU** button in stop mode until the Setting menu appears.
- 2 Rotate the Shuttle switch to select “Advanced Menu>” and press the **▶■** button to confirm.
- 3 Rotate the Shuttle switch to select “USB Bus Powered>” and press the **▶■** button to confirm.
- 4 Rotate the Shuttle switch to select “Low-Power 100mA” or “High-Power500mA” and press the **▶■** button to confirm.

To cancel the Menu mode

Press the **SEARCH/MENU** button to return the screen to the previous stage. Press repeatedly to exit menu mode.

💡 Hints

- When you connect the player to a notebook computer, connect the notebook computer to a power supply.
- The charging time will be longer if the “USB Bus Powered” is set to “Low-Power 100mA.”

Setting the Date Format (Date Disp Type)

You can select the date format of the current time (⌚ page 46) display from among “year/month/day,” “day/month/year” and “month/day/year.”

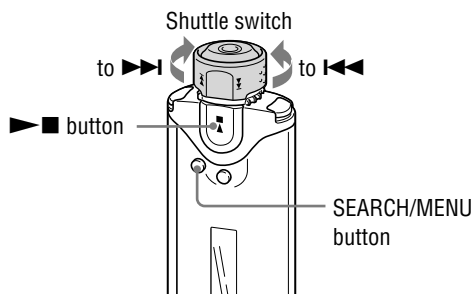

Note

- Only available when using the Music Library function in stop mode.

- 1 Press and hold the **SEARCH/MENU** button in stop mode until the Setting menu appears.
- 2 Rotate the Shuttle switch to select “Advanced Menu>” and press the ►■ button to confirm.
- 3 Rotate the Shuttle switch to select “Date Disp Type>” and press the ►■ button to confirm.
- 4 Rotate the Shuttle switch to select the desired setting and press the ►■ button to confirm.

You can select the date format setting from the following.

- Date yy/mm/dd: The date format appears “year/month/day.”
- Date dd/mm/yy: The date format appears “day/month/year.”
- Date mm/dd/yy: The date format appears “month/day/year.”

To cancel the Menu mode

Press the **SEARCH/MENU** button to return the screen to the previous stage. Press repeatedly to exit menu mode.

Setting the Time Format (Time Disp Type)

For current time (🕒 page 46), you can select either a 12 or 24 hour display.

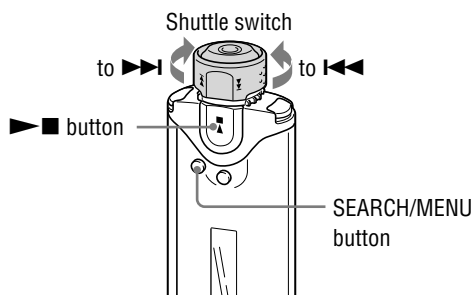

Note

- Only available when using the Music Library function in stop mode.

- 1 Press and hold the SEARCH/MENU button in stop mode until the Setting menu appears.
- 2 Rotate the Shuttle switch to select “Advanced Menu>” and press the ►■ button to confirm.
- 3 Rotate the Shuttle switch to select “Time Disp Type>” and press the ►■ button to confirm.
- 4 Rotate the Shuttle switch to select “Time 12h” or “Time 24h” and press the ►■ button to confirm.

To cancel the Menu mode

Press the SEARCH/MENU button to return the screen to the previous stage. Press repeatedly to exit menu mode.

Displaying the Player Information (Information)

Information such as product name, built-in flash memory capacity, serial number and firmware version can be shown.

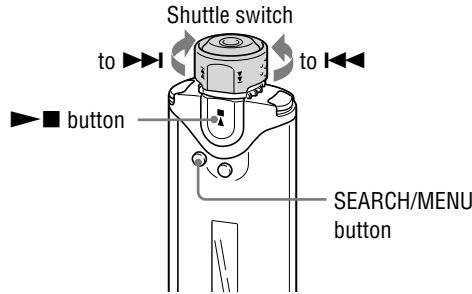

Note

- Only available when using the Music Library function in stop mode.

-
- 1 Press and hold the SEARCH/MENU button in stop mode until the Setting menu appears.**
 - 2 Rotate the Shuttle switch to select “Advanced Menu>” and press the ►■ button to confirm.**
 - 3 Rotate the Shuttle switch to select “Information>” and press the ►■ button to confirm.**

Rotate the Shuttle switch to show the following information.

- 1: product name**
 - 2: built-in flash memory capacity**
 - 3: serial number**
 - 4: version information for the player’s firmware**
-

To cancel the Menu mode

Press the SEARCH/MENU button to return the screen to the previous stage.
Press repeatedly to exit menu mode.

Listening to FM Radio

You can listen to FM radio. Charge the built-in rechargeable battery before using the player (🔌 page 61), and connect the headphones to the headphone jack.

1 Switching to the FM tuner

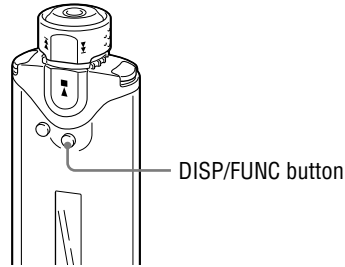

- 1 Press and hold the **DISP/FUNC** button until the **Function** menu appears.
- 2 Rotate the **Shuttle** switch to select “**FM**” and press the **▶■** button to confirm.

The FM tuner screen appears.

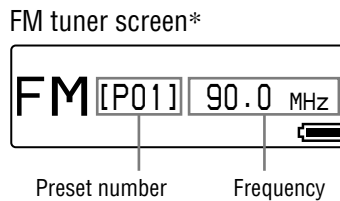



* The illustrated FM tuner screen may be different from your model.

Continued ↓



To stop the FM tuner and return to the audio player

Press and hold the DISP/FUNC button until the Function menu appears, and then select “Intelligent Shuffle” or “Music Library” from the Function menu.

To turn off the volume of the FM tuner briefly

By pressing the  button, FM tuner sound is not output. The FM tuner enters Sleep mode after about 5 seconds and the display goes off. By pressing the  button, the FM tuner sound is output again.

Note

- When you rotate the Shuttle switch to  (or ) while the player is in Sleep mode, the next (or previous) preset number or frequency is selected. At that time, the sound is not output, regardless of the VOL +/- button.

Continued 

2 Presetting broadcast stations automatically (FM Auto Preset)

You can preset receivable broadcast stations (up to 30 stations) in your area automatically by selecting “FM Auto Preset” in the Setting menu. This is convenient when you use the FM tuner for the first time or when you change to a new area.

Note

- The “FM Auto Preset” operation will delete already preset broadcast stations.

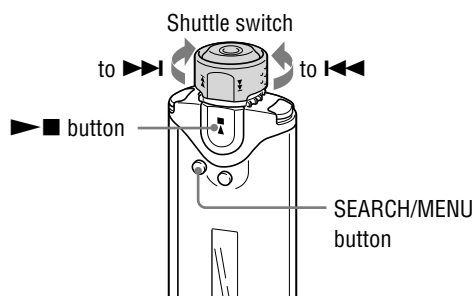

- 1 Press and hold the **SEARCH/MENU** button until the Setting menu appears.
- 2 Rotate the Shuttle switch to select “FM Auto Preset>” and press the **▶ ■** button to confirm.
- 3 Rotate the Shuttle switch to select “OK” and press the **▶ ■** button to confirm.

The receivable broadcast stations will be preset in order from low to high frequency.

“Complete” appears when presetting is complete. Then, press the **SEARCH/MENU** button repeatedly to exit menu mode; the first preset station will be received.

To stop the presetting

Select “Cancel” and press the **▶ ■** button in step 3.

To cancel the Menu mode

Press the **SEARCH/MENU** button to return the screen to the previous stage. Press repeatedly to exit menu mode.

If several unnecessary stations are received

If interference is prevalent or reception is too sensitive, change the reception setting (⊙ page 60) to “Scan Sens Low.”

3 Selecting broadcast stations

There are 2 ways (preset or manual tuning) to select broadcast stations.

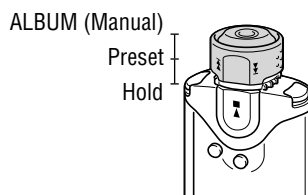

- **Preset Tuning:** Set the Shuttle switch to the center (Preset) position to enter preset tuning mode. In preset tuning mode, you can select broadcast stations by preset number.
- **Manual Tuning:** Set the Shuttle switch to the ALBUM (Manual) position to enter manual tuning mode. In manual tuning mode, you can select broadcast stations by frequency.

Preset Tuning

The preset number appears in [].

To	Shuttle switch operation
Select the next preset number	Rotate the Shuttle switch to ►►I.
Select the previous preset number	Rotate the Shuttle switch to I◄◄.

Note

- You cannot select broadcast stations if no preset stations are entered. Preset the receivable stations using “FM Auto Preset” (🔊 page 56).

Continued ↓

Manual Tuning

The frequency appears in []. When a selected frequency is already preset, the number also appears.

To	Shuttle switch operation
Select the next frequency	Rotate the Shuttle switch to ►►I.
Select the previous frequency	Rotate the Shuttle switch to I◄◄.
Select the next receivable broadcast station*	Rotate and hold the Shuttle switch to ►►I.
Select the previous receivable broadcast station*	Rotate and hold the Shuttle switch to I◄◄.

* Rotating and holding the Shuttle switch to ►►I (or I◄◄), the next (or previous) broadcast station is found. If the broadcast station is receivable, the reception is accepted.

If interference is prevalent or reception is too sensitive, change the reception setting (☞ page 60) to “Scan Sens Low.”

💡 Improving the reception

- The headphones cord serves as the antenna, so extend it as far as possible.

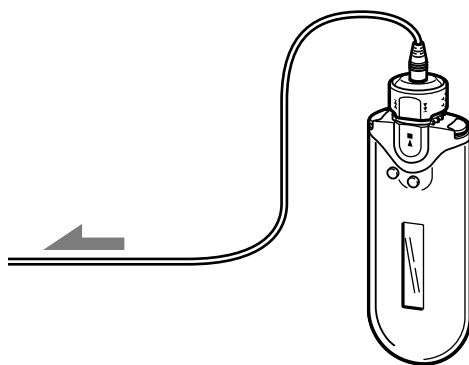

Presetting Desired Broadcast Stations

You can preset broadcast stations that “FM Auto Preset” misses (🔍 page 56).

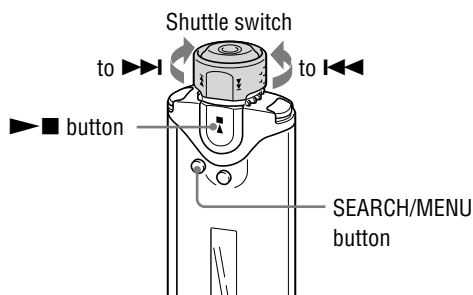

1 Select the desired frequency by Manual Tuning mode.

2 Press and hold the ▶ ■ button.

The frequency you select in step **1** is preset and the preset number appears to the left of the frequency.

Hint

- You can preset up to 30 stations (P01 to P30).

Note

- The preset number is always sorted from low to high frequency order.

To delete preset broadcast stations

1 Select the desired frequency’s preset number.

2 Press and hold the ▶ ■ button.

3 Rotate the Shuttle switch to select “OK” and press the ▶ ■ button to confirm.

The preset broadcast station is deleted and the next one appears.

Setting the Reception (Scan Sens)

When you set the “FM Auto Preset” (🔍 page 56) or “Manual Tuning” (🔍 page 58), it may receive many unnecessary broadcast stations because reception is too sensitive. In this case, set to “Scan Sens Low.”

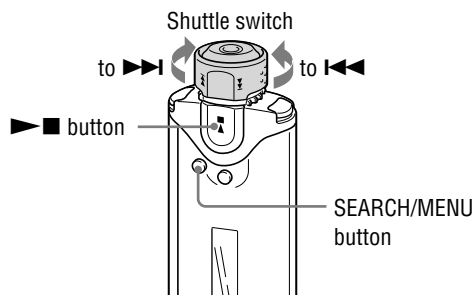

- 1 Press and hold the SEARCH/MENU button until the Setting menu appears.
- 2 Rotate the Shuttle switch to select “Scan Sens>” and press the ▶■ button to confirm.
- 3 Rotate the Shuttle switch to select “Scan Sens Low” and press the ▶■ button to confirm.

To set back the reception

Select “Scan Sens High” in step 3.

To cancel the Menu mode

Press the SEARCH/MENU button to return the screen to the previous stage. Press repeatedly to exit menu mode.

Recharging the Player

The player is rechargeable when connected to a computer with the supplied USB cable

When the remaining battery indication of the display shows: , charging is complete (charging time is approx. 120 minutes*¹).

Fully charge the player (to  in the remaining battery indication of the display) before using it for the first time.

*¹ This is the approximate charging time when the battery power is low and the “USB Bus Powered” setting ( page 50) is “High-Power500mA” under room temperature. The charging time will vary depending on remaining battery power and battery condition. If the battery is charged in a low-temperature environment, the charging time will be longer. It will also be longer if you transfer audio file(s) to the player while charging.

Battery duration*²

ATRAC format (132 kbps): Approximately 50 hours

ATRAC format (48 kbps): Approximately 45 hours

ATRAC format (128 kbps): Approximately 40 hours

MP3 format (128 kbps): Approximately 40 hours

WMA format (128 kbps): Approximately 30 hours

FM radio reception: Approximately 22 hours

*² This is when the power save setting is “Save On Normal” ( page 41). The battery duration will vary depending on temperature and usage.

On the remaining battery indication

The battery icon in the display ( page 11) changes as shown below.



The battery power gets low as shown in the battery icon. If “LOW BATTERY” appears, you cannot play back with the player. In this case, charge the battery by connecting to your computer.

Notes

- Charge the battery in an ambient temperature of between 5 to 35°C (67 to 95°F).
- The icon above “USB Connect” in the display is animated while the player accesses the computer. Do not disconnect the USB cable when the icon is moving or the data being transferred may be destroyed.
- Use of the player with a USB hub or a USB extension cable is not guaranteed. Always connect the player to the computer directly using the supplied USB cable.
- Some USB devices connected to the computer may interfere with the proper operation of the player.
- The control buttons on the player are all disabled while it is connected to a computer.
- You can display the data stored in the built-in flash memory using Windows Explorer when the player is connected to the computer.

Maximizing Battery Life

By following a few simple guidelines, you can extend the playing time available from a battery charge.

Screen display auto-off

Setting the display to turn off after a certain period of time of not using the player (approx. 15 seconds), can help to save battery power.

See “Saving Power Consumption (Power Save Mode)” (🔍 page 41) for the setting method.

Adjust track format and bit rate

The playing time varies, as battery charge can be affected by the format and bit rate of the audio tracks that are played.

For example, a full battery charge offers about 45 hours of playing time for tracks in ATRAC format at 48 kbps, but only about 40 hours for tracks in MP3 format at 128 kbps. The exact playing time available from a full charge varies with the operating conditions and environment of the player.

Do not let your computer sleep when the player is connected

If the computer enters a power saving mode, such as the system suspend, sleep or hibernation while the player is connected via the USB cable, the player’s battery is not charged. Instead, the player continues to draw power from the battery, discharging it.

Note

- Do not leave the player connected for extended periods to a laptop computer that is not connected to AC power, because the player may discharge the computer’s battery.

What are Format and Bit Rate?

What is format?

The format of a track refers to the method used by CONNECT Player to store the track's audio information when tracks are imported to CONNECT Player from the Internet or audio CDs.

Common formats include MP3, WMA and ATRAC, etc.

MP3: MP3 (MPEG-1 Audio Layer3) is a common audio compression technology developed by the MPEG working group of the ISO (International Organization for Standardization).

MP3 can compress audio files to about 1/10 the size of standard CD audio tracks.

WMA: WMA (Windows Media Audio) is a common audio compression technology developed by Microsoft Corporation. The WMA format produces the same sound quality as that of the MP3 format with smaller file size.

ATRAC: ATRAC (Adaptive Transform Acoustic Coding) is a general term used to refer to ATRAC3 and ATRAC3plus formats. ATRAC is an audio compression technology that satisfies the demand for both high sound quality and high compression rates. ATRAC3 can compress audio files to about 1/10 the size of standard CD audio tracks. ATRAC3plus, a more advanced version of ATRAC3, can compress audio files to about 1/20 the size of standard CD audio tracks.

What is bit rate?

Bit rate refers to the amount of data used to store each second of audio.

Generally, higher bit rates provide better sound quality, but require more storage space for the same length of audio.

What is the relationship between bit rate, sound quality, and storage size?

Generally, higher bit rates provide better sound quality, but require more storage space for the same length of audio, so you can store fewer tracks on the player.

Lower bit rates enable you to store more tracks, but at a lower sound quality.

For details on supported audio formats and bite rate, see  page 89.

Note

- If you import a track from a CD to CONNECT Player at a low bit rate, you cannot improve the track's sound quality by selecting a high bit rate when transferring the track from CONNECT Player to the player.

Playing Tracks Without Pauses

If you import tracks into CONNECT Player in ATRAC format and transfer them to the player, you can play them on the player continuously, without pauses between the tracks.

For example, an album that includes a long recording of a live performance with no pauses between songs can be played continuously without pauses after the tracks are imported to CONNECT player in ATRAC format and then transferred to the player.

Notes

- For tracks to be played without pauses, you must import all the tracks into CONNECT Player as a single album in the same ATRAC format.
- Although the tracks are played without pauses by the player, when ATRAC format tracks are played in CONNECT Player, pauses are still inserted between tracks.

Playing Audio Files Stored in SonicStage

You can play tracks stored in SonicStage software on the player by first importing them into CONNECT Player.

For details about importing tracks into CONNECT Player, refer to CONNECT Player Help.

Note

- Tracks in SonicStage that have an “.omg” file extension (OpenMG format files) cannot be imported into CONNECT Player. To import these tracks into CONNECT Player, convert them to the “.oma” extension format using the “SonicStage file conversion tool.” For details, refer to CONNECT Player Help.

How is Track Information Imported into the Player?

When you import CD tracks into CONNECT Player, CONNECT Player automatically retrieves information about the tracks (such as album title, artist name, and track name) from a CD database service (CDDDB, the Gracenote CD DataBase) on the Internet at no charge. When tracks are transferred to the player, this track information is transferred along with the tracks. Having this information attached to your tracks makes possible various advanced searching features of the player.

Note

- Track information of some CDs may not be able to be retrieved from the Internet. For tracks that are not in the Internet database, you can manually enter and edit track information in CONNECT Player. For details on editing track information, refer to CONNECT Player Help.

Storing Data Other Than Audio Files

You can store computer data into the built-in flash memory of the player by transferring it from your computer with Windows Explorer. The built-in flash memory appears in Windows Explorer as a removable storage drive.

Notes

- Do not use CONNECT Player while using Windows Explorer to interact with the built-in flash memory of the player.
- Always use CONNECT Player to transfer to the player audio files that you want to play. Audio files transferred with Windows Explorer cannot be played by the player.
- Do not disconnect the USB cable while transferring data between a computer and the player because the data being transferred could be damaged.
- Do not format the built-in flash memory using Windows Explorer. If you format the built-in flash memory, format it using the “Format” menu of the player (Ⓢ page 48).

Upgrading the Player's Firmware

You can update the player's firmware, ensuring you to add new features for the player by installing the latest player's firmware to the player. For details about the latest firmware information and how to install it, visit the following web site:

For customers in the USA: <http://www.sony.com/walkmansupport/>

For customers in Canada: <http://www.sony.ca/ElectronicsSupport/>

For customers in Europe: <http://www.sonydigital-link.com/DNA/>

For customers in China: <http://service.sony.com.cn/KB/>

For customers in Taiwan: <http://www.twsupport.css.ap.sony.com/>

For customers in Korea: <http://scs.sony.co.kr/walkman/>

For customers in other countries or areas: <http://www.css.ap.sony.com/>

-
- 1 Download "Digital Player Software Update tool" to your computer from the web site.**
 - 2 Connect the player to your computer, and then start up "Digital Player Software Update tool."**
 - 3 Follow the on-screen instructions to update the player's firmware.**
 - 4 When the completion message appears, click "Finish."**
"Digital Player Software Update tool" quits itself.
Firmware update is complete.
-

Troubleshooting

If the player does not function as expected, try the following steps to resolve the issue.

1 Reset the player by pressing the Reset button with a small pin.

All the tracks and settings stored on the player will not be erased even when you reset it.

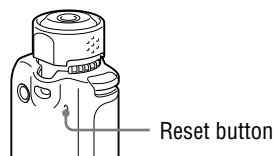

2 Find the symptoms of the issue in the following troubleshooting tables, and try any corrective actions listed.

3 Check for information about the issue in CONNECT Player Help.

4 Look for information about the issue on one of the support Web sites.

For customers in the USA, visit: <http://www.sony.com/walkmansupport/>

For customers in Canada, visit: <http://www.sony.ca/ElectronicsSupport/>

For customers in Europe, visit: <http://www.sonydigital-link.com/DNA/>

For customers in China, visit: <http://service.sony.com.cn/KB/>

For customers in Taiwan, visit: <http://www.twsupport.css.ap.sony.com/>

For customers in Korea, visit: <http://scs.sony.co.kr/walkman/>

For customers in other countries or areas, visit: <http://www.css.ap.sony.com/>

5 If the approaches listed above fail to resolve the issue, consult your nearest Sony dealer.

Operation

Symptom	Cause/Remedy
There is no sound. Noise is generated.	<ul style="list-style-type: none"> • The volume level is set to zero. → Turn the volume up (⊞ page 9). • The headphone jack is not connected properly. → Connect the headphone jack properly (⊞ page 10). • The headphone plug is dirty. → Clean the headphone plug with a soft dry cloth. • No audio files are stored in the built-in flash memory. → If “NO DATA” appears, transfer audio file(s) from the computer.

Continued ↓

Operation (continued)

Symptom	Cause/Remedy
Buttons do not work.	<ul style="list-style-type: none"> • The Shuttle switch is set to the HOLD position. → Set the Shuttle switch to the center (normal) position (🔧 page 9). • The player contains moisture condensation. → Wait a few hours to let the player dry. • The remaining battery power is insufficient. → Charge the battery (🔧 page 61).
The transferred tracks cannot be found.	<ul style="list-style-type: none"> • The Play Range is shortened by the Music Library function. → Select “All Song” in the Search menu (🔧 page 12). • The built-in flash memory of the player was formatted using Windows Explorer. → Format the built-in flash memory using the “Format” menu of the player (🔧 page 48). • The supplied USB cable is disconnected while data is being transferred. → Transfer usable files back to your computer and format the built-in flash memory using the “Format” menu of the player (🔧 page 48).
The volume is not loud enough.	<ul style="list-style-type: none"> • AVLS is enabled. → Disable AVLS (🔧 page 39).
There is no sound from the right channel of the headphones.	<ul style="list-style-type: none"> • The headphone jack is not fully inserted. → Connect the headphones into the jack until it clicks (🔧 page 10). • The headphone extension cord is not properly connected to the headphone jack of the player or the headphone cord. → Connect the headphone extension cord to the headphone jack/cord of the player until it clicks (🔧 page 10).
Playback has stopped suddenly.	<ul style="list-style-type: none"> • The remaining battery power is insufficient. → Charge the battery (🔧 page 61).

Display window

Symptom	Cause/Remedy
“□” appears for a title.	<ul style="list-style-type: none"> • Characters that cannot appear on the player are involved. → Use the supplied CONNECT Player to rename the title with appropriate characters.

Continued ↓

Charging the battery

Symptom	Cause/Remedy
Battery life is short.	<ul style="list-style-type: none"> • The operating temperature is below 5°C (67°F). → Battery life becomes shorter due to the battery characteristics. This is not malfunction. • The battery is required to be replaced. → Consult your near Sony dealer. • Battery charging time is not enough. → Charge the battery longer if the USB connection (USB Bus Powered) is set to “Low-Power 100mA” (Ⓜ page 50).

Connection with the computer/CONNECT Player

Symptom	Cause/Remedy
The CONNECT Player software cannot be installed.	<ul style="list-style-type: none"> • The computer’s operating system software is not compatible with CONNECT Player. → Refer to CONNECT Player Readme. • All Windows applications are not closed. → If you start the installation while other programs are running, an error may occur. This is especially true for programs that require significant system resources, such as virus-protection software. • There is not enough free space on the hard disk of your computer. → You need 200 MB or more of free space. Delete any unnecessary files on your computer. • You are not logged on as an “Administrator.” → If you are not logged on as an “Administrator,” the installation of CONNECT Player might fail. Make sure that you are logged on using an account with “Administrator” privileges.
The progress bar on the display of your computer is not moving. The access lamp of your computer has not lit for a few minutes.	<ul style="list-style-type: none"> • The installation is progressing normally. Please wait. The installation may take 30 minutes or more, depending on your CD drive and system environment.
CONNECT Player does not start up.	<ul style="list-style-type: none"> • Your computer’s system environment has changed, perhaps due to an update of the Windows operating system.

Continued ↓

Connection with the computer/CONNECT Player (continued)

Symptom	Cause/Remedy
<p>“USB Connect” does not appear when connected to the computer with the USB cable.</p>	<ul style="list-style-type: none"> • The USB cable is not connected properly. → Disconnect the USB cable, and then reconnect it. • A USB hub is being used. → Connecting the player via a USB hub may not work and is not supported. Connect the supplied USB cable directly to the computer. • Please wait for the authentication of the CONNECT Player software. • Another application is running on the computer. → Disconnect the USB cable, wait a few minutes, and reconnect the cable. If the problem persists, disconnect the USB cable, restart the computer, and then reconnect the USB cable. • The player USB connection (USB Bus Powered) is set to “High-Power500mA.” → Set the “USB Bus Powered” to “Low-Power 100mA” (☞ page 50). • The installation of the CONNECT Player software was not successful. → Disconnect the player from your computer, and reinstall the software using the supplied CD-ROM (☞ “Quick Start Guide”). Audio tracks registered with the earlier installation will be available with the new CONNECT Player installation.
<p>The player is not recognized by the computer when it is connected to the computer.</p>	<ul style="list-style-type: none"> • The USB cable is not connected properly. → Disconnect the USB cable, and then reconnect it. • A USB hub is being used. → Connecting the player via a USB hub may not work and is not supported. Connect the supplied USB cable directly to the computer. • The installation of the CONNECT Player software was not successful. → Disconnect the player from your computer, and reinstall the software using the supplied CD-ROM (☞ “Quick Start Guide”). Audio tracks registered with the earlier installation will be available with the new CONNECT Player installation.

Continued ↓

Connection with the computer/CONNECT Player (continued)

Symptom	Cause/Remedy
Audio data cannot be transferred to the player from your computer.	<ul style="list-style-type: none"> • The USB cable is not connected properly. → Disconnect the USB cable, and then reconnect it. • There is not enough free space in the built-in flash memory. → Transfer any unnecessary tracks back to your computer to increase free space. • You have already transferred over 65,535 tracks or over 8,192 playlists to the built-in flash memory, or you are trying to transfer a playlist that contains over 999 tracks. • Tracks with a limited playing period or playing count may not be transferred due to restrictions set by copyright holders. For details on the settings of each audio file, contact the distributor.
Only a small number of tracks can be transferred to the player. (Available recording time is short.)	<ul style="list-style-type: none"> • There is not enough free space in the built-in flash memory. → Transfer any unnecessary tracks back to your computer to increase free space. • Non-audio data is stored in the built-in flash memory. → Move non-audio data to the computer to increase free space.
Audio data cannot be transferred back to your computer from the player.	<ul style="list-style-type: none"> • The computer you are trying to transfer tracks to is not the same computer from which the tracks were originally transferred. → Tracks can be transferred only to the computer that they originally came from. • The audio data has been deleted from the computer you used to transfer to the player. → The audio data cannot be transferred back to your computer if the track is deleted from the computer used to transfer to the player.
The player becomes unstable while it is connected to the computer.	<ul style="list-style-type: none"> • A USB hub or USB extension cable is being used. → Connecting the player via a USB hub or extension cable may not work and is not supported. Connect the supplied USB cable directly to the computer.

Continued ↓

FM Tuner

Symptom	Cause/Remedy
You cannot hear the FM broadcast well.	<ul style="list-style-type: none"> • The receiving frequency is not fully tuned in. → Select the frequency manually to improve reception (☞ page 58).
Reception is weak and sound quality is poor.	<ul style="list-style-type: none"> • The radio signal is weak. → Listen to the FM broadcast near a window since the signal may be weak inside buildings or vehicles. • The headphone cord does not extend enough. → The headphone cord functions as an antenna. Extend the headphone cord as far as possible.
The FM broadcast is affected by interference.	<ul style="list-style-type: none"> • An apparatus emitting radio signals, such as a mobile phone is being used near the player. → When using such apparatus as mobile phones, keep them away from the player.

Other

Symptom	Cause/Remedy
There is no beep sound when the player is operated.	<ul style="list-style-type: none"> • Beep is set to “Beep OFF.” → Set “Beep ON” in the “Beep” menu (☞ page 40).
The player gets warm.	<ul style="list-style-type: none"> • While charging, the player may become slightly warm.

Error Messages

Follow the instructions below if an error message appears in the display.

Message	Meaning	Remedy
AVLS (blinks)	The volume level exceeds the rated value while AVLS is enabled.	Turn the volume down or disable AVLS (☞ page 39).
CANNOT PLAY	<ul style="list-style-type: none"> • The player cannot play certain files because of incompatible formats. • Transferring has been interrupted forcefully. 	If the track which cannot be played is unnecessary, you can erase it from the built-in flash memory. For details, refer to “To delete abnormal data from the built-in flash memory” (☞ page 77).
CHARGE ERROR	The power supply is abnormal.	Try using another computer.
DATA ACCESS	Accessing the built-in flash memory.	Please wait for access to complete. This message appears while the built-in flash memory is initiating.
EXPIRED	<ul style="list-style-type: none"> • The time limit for how long the track can be played has been exceeded. • The audio file information in the player has not been updated. 	<ul style="list-style-type: none"> • Connect the player to CONNECT Player and update the audio file information. • If the track which cannot be played is unnecessary, you can erase it from the built-in flash memory. For details, refer to “To delete abnormal data from the built-in flash memory” (☞ page 77).
FILE ERROR	<ul style="list-style-type: none"> • The file cannot be read. • The file is not normal. 	Transfer the normal audio file back to the computer and then format the player. For details, refer to “To delete abnormal data from the built-in flash memory” (☞ page 77).

Continued ↓

Message	Meaning	Remedy
FORMAT ERROR	The built-in flash memory was formatted on a computer.	Format the player using the “Format” menu. For details, refer to “To delete abnormal data from the built-in flash memory” (☞ page 77).
FUNCTION LIMITED	The player is connected to software other than CONNECT Player.	Connect the player only to CONNECT Player.
HOLD	The player cannot be operated because the Shuttle switch is set to the HOLD position.	To operate the player, set the Shuttle switch to the center (normal) position (☞ page 9).
LOW BATTERY	The battery is low.	You must charge the battery (☞ page 61).
MG ERROR	An unauthorized distribution file is detected for copyright protection.	Transfer the normal audio file back to the computer and then format the player. For details, refer to “To delete abnormal data from the built-in flash memory” (☞ page 77).
NO DATA	There are no audio files in the built-in flash memory.	If there are no audio files in the built-in flash memory, use CONNECT Player to transfer audio files.
NO DATABASE	The player has been disconnected from CONNECT Player while transferring audio files.	Transfer the normal audio file back to the computer and then format the player. For details, refer to “To delete abnormal data from the built-in flash memory” (☞ page 77).
NO ITEM	The searched track does not exist on the player.	Use CONNECT Player to transfer audio files.
PRESET FULL	30 broadcast stations are already preset.	You can preset up to 30 broadcast stations. If you want to preset more stations, delete unnecessary stations first (☞ page 59), then preset the stations you want.

Message	Meaning	Remedy
USB Connect	The player is connected to a computer.	This is not a malfunction. You can operate the player using CONNECT Player, but you cannot operate the controls on the player.
	Icon animates from left to right: Accesses to the built-in flash memory is in progress.	The player is accessing to the built-in flash memory. Wait until the access completes. This message is displayed when transferring data to the built-in flash memory or formatting the player.

To delete abnormal data from the built-in flash memory

If “CANNOT PLAY,” “EXPIRED,” “FILE ERROR,” “FORMAT ERROR,” “MG ERROR,” or “NO DATABASE” appears, there is a problem with all or part of the data stored in the built-in flash memory.

Please follow the procedure below to erase data you cannot play.

- 1** Connect the player to the computer, and start CONNECT Player.
- 2** If you have already specified the data with problems, erase the data using CONNECT Player.
- 3** If the problem persists, transfer all data without problems back to the computer using CONNECT Player while the player is connected to the computer.
- 4** Disconnect the player from the computer and then format the built-in flash memory using the “Format” menu (🔧 page 48).

Uninstalling CONNECT Player

To uninstall the supplied software from your computer, follow the procedure below.

-
- 1 Click “Start”– “Control Panel.”¹⁾
 - 2 Double-click “Add/Remove Programs.”
 - 3 Click “CONNECT Player” in the “Currently Installed Programs” list, and then click “Change and Remove.”²⁾

Follow the displayed instruction and restart your computer.

The uninstallation is completed when the computer has restarted.

¹⁾ “Settings” – “Control Panel” in the case of Windows 2000.

²⁾ “Change/Remove” in the case of Windows 2000.

Note

- When you install CONNECT Player, OpenMG Secure Module is installed at the same time. Do not delete OpenMG Secure Module since it may be used by other software.

Owner's Record

The model and serial numbers are located on the rear of the player. Record the serial number in the space provided below. Refer to these numbers whenever you call upon your Sony dealer regarding this product.

Model No. _____

Serial No. _____

WARNING

To reduce the risk of fire or electric shock, do not expose this apparatus to rain or moisture.

Do not install the appliance in a confined space, such as a bookcase or built-in cabinet.

To reduce the risk of fire, do not cover the ventilation of the apparatus with newspapers, tablecloths, curtains, etc. And do not place lighted candles on the apparatus.

To reduce the risk of fire or electric shock, do not place objects filled with liquids, such as vases, on the apparatus.

For Customers in the USA

INFORMATION:

This equipment has been tested and found to comply with the limits for a Class B digital device, pursuant to Part 15 of the FCC Rules. These limits are designed to provide reasonable protection against harmful interference in a residential installation. This equipment generates, uses, and can radiate radio frequency energy and, if not installed and used in accordance with the instructions, may cause harmful interference to radio communications.

However, there is no guarantee that interference will not occur in a particular installation. If this equipment does cause harmful interference to radio or television reception, which can be determined by turning the equipment off and on, the user is encouraged to try to correct the interference by one or more of the following measures:

- Reorient or relocate the receiving antenna.
- Increase the separation between the equipment and receiver.
- Connect the equipment into an outlet on a circuit different from that to which the receiver is connected.
- Consult the dealer or an experienced radio/TV technician for help.

You are cautioned that any changes or modifications not expressly approved in this manual could void your authority to operate this equipment.

Continued ↓

If you have any questions about this product:**Visit:**

www.sony.com/walkmansupport

Contact:

Sony Customer Information Service Center at 1-(866)-456-7669

Write:

Sony Customer Information Services Center
12451 Gateway Blvd.,
Fort Myers, FL 33913

Model NW-A605/A607/A608**Declaration of Conformity**

Trade Name: SONY
Model No.: NW-A605/A607/A608
Responsible Party: Sony Electronics Inc.
Address: 16450 W. Bernardo Dr,
San Diego, CA 92127
USA
Telephone Number: 858-942-2230

This device complies with Part 15 of the FCC Rules. Operation is subject to the following two conditions: (1) This device may not cause harmful interference, and (2) this device must accept any interference received, including interference that may cause undesired operation.

Continued ↓

For Customers in the USA and Canada

RECYCLING LITHIUM-ION BATTERIES

Lithium-ion batteries are recyclable.

You can help preserve our environment by returning your used rechargeable batteries to the collection and recycling location nearest you.



For more information regarding recycling of rechargeable batteries, call toll free 1-800-822-8837, or visit <http://www.rbr.c.org/>.

Caution: Do not handle damaged or leaking Lithium-ion batteries.

Disposal of Old Electrical & Electronic Equipment (Applicable in the European Union and other European countries with separate collection systems)



This symbol on the product or on its packaging indicates that this product shall not be treated as household waste. Instead it shall be handed over to the applicable collection point for the recycling of electrical and electronic equipment. By ensuring this product is disposed of correctly, you will help prevent potential negative consequences for the environment and human health, which could otherwise be caused by inappropriate waste handling of this product. The recycling of materials will help to conserve natural resources. For more detailed information about recycling of this product, please contact your local Civic Office, your household waste disposal service or the shop where you purchased the product.

Applicable accessories: Headphones

For Customers in Russia

Произведено в Китае

Изготовитель: Сони Корпорейшн

Адрес: 6-7-35 Киташинагава, Шинагава-ку,

Токио 141-0001, Япония

Notes on Disposing of the Player

This player has a built-in lithium-ion rechargeable battery. When you dispose of the player, be sure to dispose of it properly.

Some countries may regulate disposal of the battery used to power this product. Please consult with your local authority.

Notes

- Never disassemble the player except when disposing it.
- Be careful when handling internal metallic components of the player. Pay particular attention to component edges.

Continued ↓

To remove the Lithium-Ion battery

- 1** Remove the screws using a Phillips screwdriver.

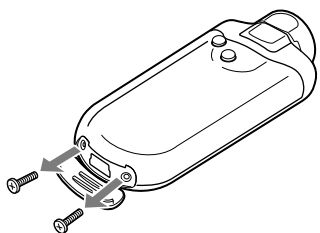

- 2** Remove the cover A.

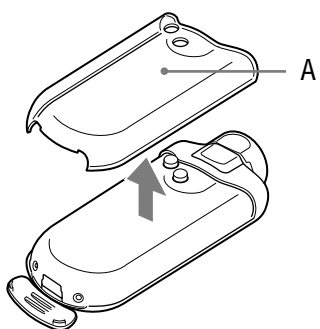

- 3** Remove the cover B.

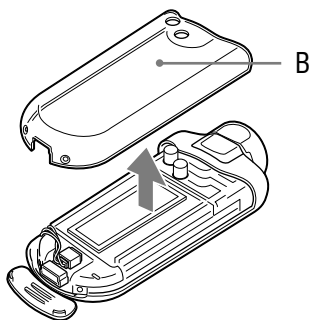

- 4** Remove the connector.

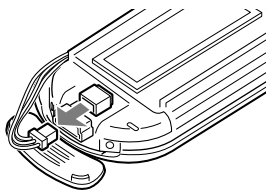

- 5** Remove the board.

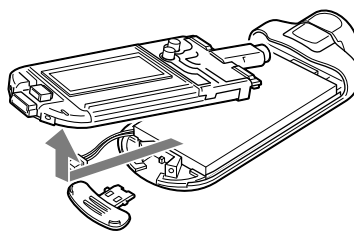

- 6** Remove the battery.

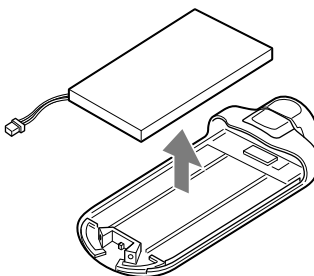

Precautions

On safety

Be sure not to short-circuit the terminals of the player with other metallic objects.

On installation

- Never use the player where it will be subjected to extremes of light, temperature, moisture or vibration.
- Never leave the player exposed to high temperature, such as in a car parked in the sun or under direct sunlight.

On heat build-up

Heat may build up in the player while charging if it is used for an extended period of time.

On the headphones

Road safety

Do not use headphones while driving, cycling, or operating any motorized vehicle. It may create a traffic hazard and is illegal in many areas. It can also be potentially dangerous to play at a high volume while walking, especially at pedestrian crossings. You should exercise extreme caution or discontinue use in potentially hazardous situations.

Preventing hearing damage

Avoid using the headphones at a high volume. Hearing experts advise against continuous, loud and extended play. If you experience a ringing in your ears, reduce the volume or discontinue use.

Continued ↓

Caring for others

Keep the volume at a moderate level. This will allow you to hear outside sounds and to be considerate to the people around you.

Warning

If there is lightning when you are using the player, take off the headphones immediately.

On the use

- When using a strap, be careful to avoid hooking it on objects you pass by.
- Do not use the player on an aircraft.

On cleaning

- Clean the player's case with a soft cloth, such as cleaning cloth for eyeglasses.
- If the player's case becomes very dirty, clean it with a soft cloth slightly moistened with water or a mild detergent solution.
- Do not use any type of abrasive pad, scouring powder, or solvent, such as alcohol or benzene, as it may mar the finish of the case.
- Clean the headphone plug periodically.
- Be careful not to let water get into the player from the opening near the connector.

If you have any questions or problems concerning the player, please consult your nearest Sony dealer.

NOTES

- The recorded music is limited to private use only. Use of the music beyond this limit requires permission of the copyright holders.
- Sony is not responsible for incomplete recording/downloading or damaged data due to problems of the player or computer.

Continued ↓

On software

- Copyright laws prohibit reproducing the software or the manual accompanying it in whole or in part, or renting the software without the permission of the copyright holder.
- In no event will SONY be liable for any financial damage, or loss of profits, including claims made by third parties, arising out of the use of the software supplied with this player.
- In the event a problem occurs with this software as a result of defective manufacturing, SONY will replace it. However, SONY bears no other responsibility.
- The software provided with this player cannot be used with equipment other than that which is so designated.
- Please note that, due to continued efforts to improve quality, the software specifications may be changed without notice.
- Operation of this player with software other than that provided is not covered by the warranty.
- The ability to display the languages on your CONNECT Player will depend on the installed OS on your PC. For better results, please ensure that the installed OS is compatible with the desired language you want to display.
 - We do not guarantee all the languages will be able to be displayed properly on your CONNECT Player.
 - User-created characters and some special characters may not be displayed.
- The explanations in this manual assume that you are familiar with the basic operations of Windows.

For details on the use of your computer and operating system, please refer to the respective manuals.

Continued ↓

On sample audio data

The player is pre-installed with sample audio data so that you can try it out right away. The pre-installed sample audio data is for the purpose of trial listening only, therefore, you cannot transfer it to your computer. To delete this audio data, delete it using CONNECT Player.

Depending on your region, sample audio data may not be pre-installed in the player.

- The recorded music is limited to private use only. Use of the music beyond this limit requires permission of the copyright holders.
- Sony is not responsible for incomplete recording/downloading or damaged data due to problems of the player or computer.
- Depending on the types of the text and characters, the text shown on the player may not be displayed properly on device. This is due to:
 - The capacity of the connected player.
 - The player is not functioning normally.
 - The ID3 TAG information for the track is written in the language or the character that is not supported by the player.

About the customer support Web site

If you have any questions about or issue with this product, visit the following web sites.

For customers in the USA: <http://www.sony.com/walkmansupport/>

For customers in Canada: <http://www.sony.ca/ElectronicsSupport/>

For customers in Europe: <http://www.sonydigital-link.com/DNA/>

For customers in China: <http://service.sony.com.cn/KB/>

For customers in Taiwan: <http://www.twsupport.css.ap.sony.com/>

For customers in Korea: <http://scs.sony.co.kr/walkman/>

For customers in other countries or areas: <http://www.css.ap.sony.com/>

On Copyrights

- CONNECT Player and the CONNECT Player logo are trademarks or registered trademarks of Sony Corporation.
- OpenMG, ATRAC, ATRAC3, ATRAC3plus and their logos are trademarks of Sony Corporation.
- “WALKMAN” is a registered trademark of Sony Corporation to represent Headphone Stereo products.  WALKMAN is a trademark of Sony Corporation.
- Microsoft, Windows, Windows NT and Windows Media are trademarks or registered trademarks of Microsoft Corporation in the United States and/or other countries.
- Adobe and Adobe Reader are trademarks or registered trademarks of Adobe Systems Incorporated in the United States and/or other countries.
- MPEG Layer-3 audio coding technology and patents licensed from Fraunhofer IIS and Thomson.
- IBM and PC/AT are registered trademarks of International Business Machines Corporation.
- Pentium is a trademark or a registered trademark of Intel Corporation.
- CD and music-related data from Gracenote, Inc., copyright © 2000-2004 Gracenote.

Gracenote CDDDB® Client Software, copyright 2000-2004 Gracenote. This product and service may practice one or more of the following U.S. Patents: #5,987,525; #6,061,680; #6,154,773, #6,161,132, #6,230,192, #6,230,207, #6,240,459, #6,330,593, and other patents issued or pending. Services supplied and/or device manufactured under license for following Open Globe, Inc. United States Patent 6,304,523. Gracenote and CDDDB are registered trademarks of Gracenote.

The Gracenote logo and logotype, and the “Powered by Gracenote” logo are trademarks of Gracenote.

- All other trademarks and registered trademarks are trademarks or registered trademarks of their respective holders. In this manual, TM and ® marks are not specified.

Program ©2005 Sony Corporation

Documentation ©2005 Sony Corporation

Specifications

Audio compression technology

- MPEG-1 Audio Layer-3 (MP3)
- Windows Media Audio (WMA)*
- Adaptive Transform Acoustic Coding (ATRAC)

* WMA format tracks can be supported after updating the player's firmware to version 2.0 or later. To view the firmware version of your player, see "Displaying the Player Information (Information)" on page 53. To update your player's firmware, see "Upgrading the Player's Firmware" on page 68.

Maximum recordable number of track and time (Approx.)*

* When transferring four-minute tracks.

	NW-A605		NW-A607		NW-A608	
Bit rate	Tracks	Time	Tracks	Time	Tracks	Time
48 kbps	345	23 hr. 00 min.	695	46 hr. 20 min.	1,350	90 hr. 00 min.
64 kbps	255	17 hr. 00 min.	520	34 hr. 40 min.	1,000	66 hr. 40 min.
96 kbps	170	11 hr. 20 min.	345	23 hr. 00 min.	700	46 hr. 40 min.
128 kbps	130	8 hr. 40 min.	260	17 hr. 20 min.	525	35 hr. 00 min.
132 kbps	125	8 hr. 20 min.	250	16 hr. 40 min.	510	34 hr. 00 min.
160 kbps	100	6 hr. 40 min.	205	13 hr. 40 min.	420	28 hr. 00 min.
192 kbps	85	5 hr. 40 min.	170	11 hr. 20 min.	350	23 hr. 20 min.
256 kbps	65	4 hr. 20 min.	130	8 hr. 40 min.	260	17 hr. 20 min.
320 kbps	50	3 hr. 20 min.	105	7 hr. 00 min.	210	14 hr. 00 min.

Supported bit rates

MP3: 32 to 320 kbps variable bit rate-compliant

WMA: 48 to 192 kbps variable bit rate-compliant

ATRAC: 48 / 64 / 66 (ATRAC3)* / 96 / 105 (ATRAC3)* / 128 / 132 (ATRAC3) / 160 / 192 / 256 / 320 kbps

* CD recording cannot be done using CONNECT Player software in ATRAC3 at 66/105 kbps.

Sampling frequency

MP3, WMA, ATRAC: 44.1 kHz

Frequency response

20 to 20,000 Hz (single signal measurement)

FM Frequency range

87.5 to 108.0 MHz

IF (FM)

225 kHz

Antenna

Headphone cord antenna

Interface

Headphone: Stereo mini

Hi-speed USB (USB 2.0 compliant)

Continued ↓

Signal-to-noise ratio (S/N)

80 dB or more

Operating temperature

5°C to 35°C (67°F to 95°F)

Power source

- Built-in rechargeable lithium-ion battery
- USB power (from a computer through supplied USB cable)

Battery life (continuous playback)*

ATRAC format: Approximately 50 hours (Playback at 132 kbps)

ATRAC format: Approximately 45 hours (Playback at 48 kbps)

ATRAC format: Approximately 40 hours (Playback at 128 kbps)

MP3 format: Approximately 40 hours (Playback at 128 kbps)

WMA format: Approximately 30 hours (Playback at 128 kbps)

FM radio reception: Approximately 22 hours

* This is when the power save setting is "Save ON Normal" (Ⓢ page 41). The battery duration will vary depending on temperature and usage.

Dimension

84.9 × 28.8 × 13.9 mm (3 3/8 × 1 3/16 × 9/16 inches)

(w/h/d, projecting parts not included)

Mass

Approx. 48 g (1.7 oz)

CONNECT Player**Minimum System Requirements**

- Computer: IBM PC/AT or compatible computer preinstalled with Windows.
CONNECT Player is compatible with the following Windows operating systems:
 - Windows 2000 Professional (Service Pack 4 or later),
 - Windows XP Home Edition,
 - Windows XP Professional,
 - Windows XP Media Center Edition,
 - Windows XP Media Center Edition 2004,
 - Windows XP Media Center Edition 2005
- CPU: Pentium III 450 MHz or higher
- RAM: 256 MB or greater (512 MB is recommended)
- Hard Disk: 200 MB or greater of available space
More space may be required depending on the version of the operating system. Additional space is required for storing music data.
- Display:
 - Screen Resolution: 800 × 600 pixels (or higher) (1024 × 768 is recommended)
 - Colours: Medium (16 bit) (or higher) (CONNECT Player may not operate properly at colour settings at or below 256 colours.)
- CD-ROM drive (supporting Digital MusicCD playback capabilities using WMD)
To create original CDs or to back up audio CDs a CD-R/RW drive is required.

Design and specifications are subject to change without notice.

US and foreign patents licensed from Dolby Laboratories.

Index

A

A-B Repeat.....30
 Accessories7
 Adobe Reader.....3
 Album8, 15
 All Song12
 Artist13
 Artist Link Shuffle24
 ATRAC.....63
 AVLS (Limiting the volume)39

B

Battery.....61, 62
 Beep (Beep sound).....40
 Bit rate.....63

C

CD-ROM.....7
 Clock.....42
 Computer.....3
 CONNECT Player3
 Cue/Rev.....36

D

Date-Time46
 Date Disp Type.....51
 DISP/FUNC button.....6, 9
 Display11
 Display mode42
 Display Screen45

E

Error Messages.....75

F

Fast-forward8
 Fast-rewind.....8
 Favorite 10019
 FM.....54
 FM Auto Preset56
 Format (Formatting).....48
 Format of a track63

G

Genre.....16

H

Headphones.....7, 10, 84
 HOLD function
 (Locking the controls)9

I

Information53
 Intelligent Shuffle22

M

Manual Volume38
 MP3.....63
 Music Library.....12
 My Favorite Shuffle22

P

Playback.....9
 Playlist20
 Play Range12
 Power Save Mode41
 Preset Volume.....37

R

Radio	54
Recent Transfer	21
Recharging	61
Release Year	18
Repeat	27
REPEAT/SOUND button.....	6, 10
Repeat count.....	28
Repeat Mode	28
Reset.....	69

S

Scan Sens	60
SEARCH/MENU button.....	6, 9
Searching for Tracks	12
Sentence Repeat.....	32
Serial Number	53
SHUF	29
Shuttle switch.....	8
Skip to the beginning of a track	8
Sound preset (Digital sound preset)	34
Sports Shuffle.....	26

T

Time Disp Type.....	52
Time Machine Shuffle.....	25
Track Information	66
Track Repeat	29
Transferring.....	3
Troubleshooting	69
Tuner	54

U

Uninstalling.....	78
USB Bus Powered (USB connection setting)	50

V

Volume	9
Volume Mode.....	37

W

Windows Explorer	61, 67
WMA	63