

SUZUKI

GSX 1100, GS 1150

SERVICE MANUAL

THIS MANUAL COVERS THREE MODELS OF THE GSX1100 SERIES:
GSX1100E, GSX1100ES AND GSX1100EF.

IN CANADA THIS MOTORCYCLE SHOULD BE IDENTIFIED AS
GS1150E AND GS1150EF.

99500-39032-01E

(英)

FOREWORD

The SUZUKI GSX1100E has been developed as a new generation motorcycle to the GS-series models. It is packed with highly advanced design concepts including a fully adjustable suspension system, a full-transistorized ignition system and a new highly efficient combustion system (TSCC).

Combined light weight chassis with high performance engine, the GSX1100E provides excellent riding stability and riding comfort.

This service manual has been produced primarily for experienced mechanics whose job is to inspect, adjust, repair and service SUZUKI motorcycles. Apprentice mechanics and do-it-yourself mechanics, will also find this manual an extremely useful guide.

Model GSX1100E manufactured to standard specifications is the main subject matter of this Manual. However, the GSX1100E machines distributed in your country might differ in minor respects from the standard-specification and, if they do, it is because some minor modifications (which are of no consequence in most cases as far as servicing is concerned) had to be made to comply with the statutory requirements of your country.

This manual contains up-to-date information at the time of its issue. Later made modifications and changes will be explained to each SUZUKI distributor in respective markets, to whom you are kindly requested to make query about updated information, if any.

SUZUKI MOTOR CORPORATION

Motorcycle Technical Service Department

Quoting, copying or otherwise using any part of this manual without explicit authorization from Suzuki Motor Corporation is not permitted as all rights to the publication are reserved under copyright law.

VIEW OF SUZUKI GSX1100E



LEFT SIDE



RIGHT SIDE

GROUP INDEX

GENERAL INFORMATION	1
PERIODIC MAINTENANCE AND TUNE-UP PROCEDURES	2
SERVICING ENGINE	3
FUEL AND LUBRICATION SYSTEM	4
ELECTRICAL SYSTEM	5
CHASSIS	6
SERVICING INFORMATION	7
GSX1100ES/EF GS1150EF	8
GSX1100EF/ESF/EFF ('85-MODEL) GS1150EF/ESF/EFF	9
GSX1100EG/ESG/EFG, GSX1150EFG GS1150EG/EFG ('86-MODEL)	10
APPENDIX	11

GENERAL INFORMATION

CONTENTS

SERIAL NUMBER LOCATIONS	1- 1
FUEL AND OIL RECOMMENDATIONS	1- 1
BREAKING-IN PROCEDURES	1- 2
CYLINDER IDENTIFICATION	1- 2
SPECIAL FEATURES	1- 2
BLOWBY GAS RECYCLING	1- 2
TSCC (TWIN SWIRL COMBUSTION CHAMBER)	1- 3
PRECAUTIONS AND GENERAL INSTRUCTIONS	1- 7
SPECIAL MATERIALS	1- 8
SPECIFICATIONS	1-10

SERIAL NUMBER LOCATIONS

VIN NUMBER

The VIN (Vehicle Identification Number) ① is stamped on the steering head pipe.

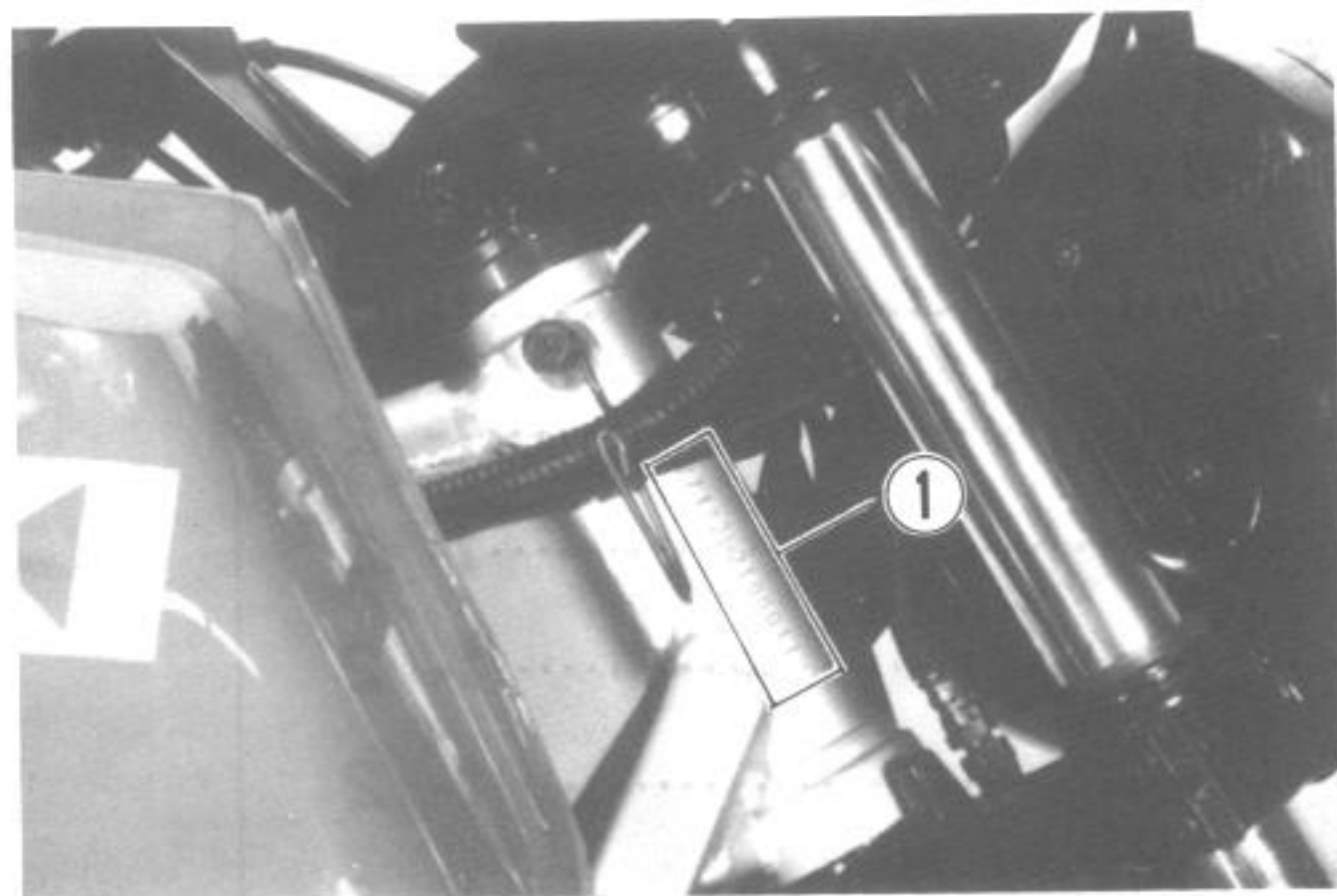

ENGINE NUMBER

The engine serial number ② is located on the right side of the crankcase.

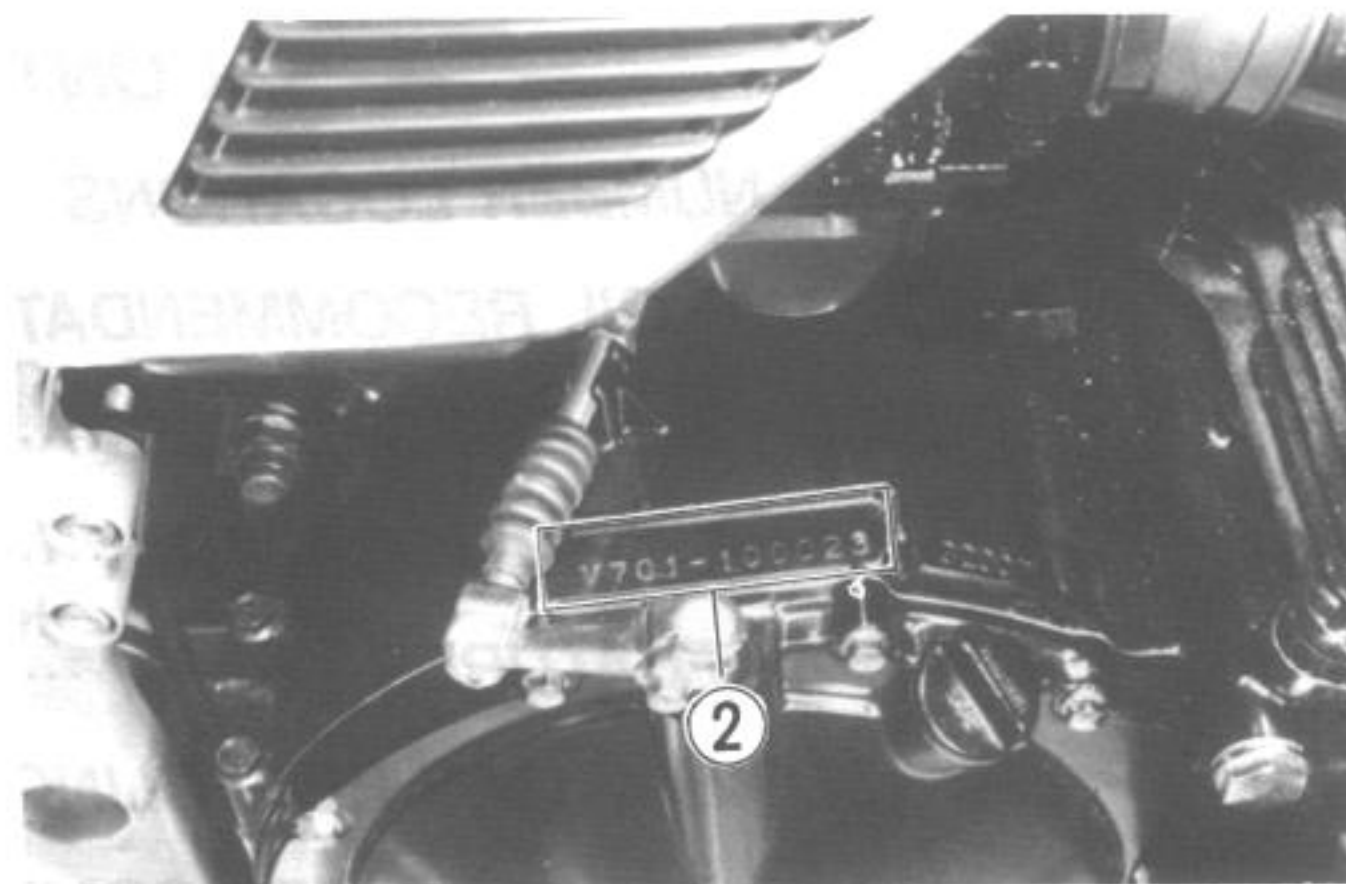

FUEL AND OIL RECOMMENDATIONS

FUEL

Gasoline used should be graded 85–95 octane or higher. An unleaded or low-lead gasoline type is recommended.

ENGINE OIL

Be sure that the engine oil you use comes under API classification of SE or SF and that its viscosity rating is SAE 10W/40. If SAE 10W/40 motor oil is not available, select the oil viscosity according to the following chart:

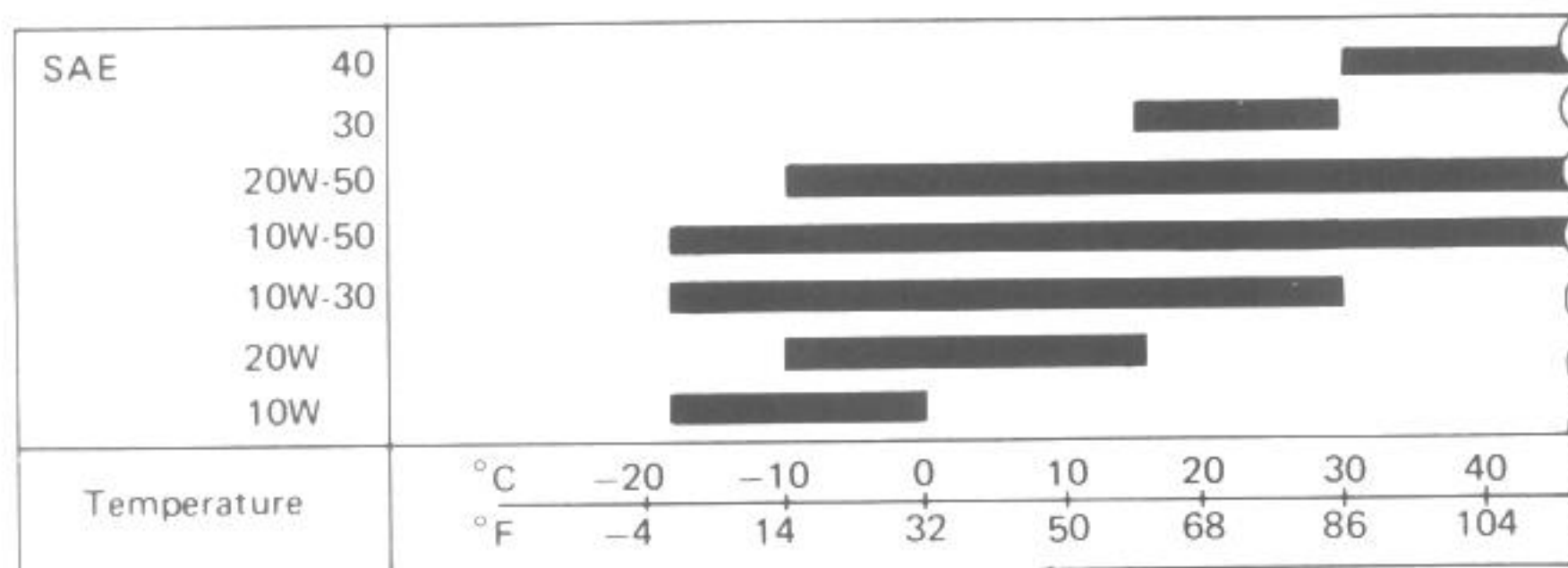

BRAKE FLUID

Specification and classification	SAE J1703, DOT3, DOT4
99000-23021	SUZUKI Brake fluid

NOTE:

- * Since the brake system of this motorcycle is filled with a glycol-based brake fluid by the manufacture, do not use or mix different types of fluid such as silicone-based and petroleum-based fluid for refilling the system, otherwise serious damage will result.
- * Do not use any brake fluid taken from old or used or unsealed containers.
- * Never re-use brake fluid left over from the previous servicing and stored for a long period.

FRONT FORK OIL

Use fork oil #15

99000-99044-15G

SUZUKI fork oil #15

BREAKING-IN PROCEDURES

During manufacture only the best possible materials are used and all machined parts are finished to a very high standard but it is still necessary to allow the moving parts to "BREAK-IN" before subjecting the engine to maximum stresses. The future performance and reliability of the engine depends on the care and restraint exercised during its early life. The general rules are as follows:

- Keep to these breaking-in engine speed limits:

Initial 800 km (500 miles)	Below 4 000 r/min
Up to 1 600 km (1 000 miles)	Below 6 000 r/min
Over 1 600 km (1 000 miles)	Below 9 000 r/min

- Upon reaching an odometer reading of 1 600 km (1 000 miles), you can subject the motorcycle to full throttle operation. However, do not exceed 9 000 r/min at any time.
- Do not maintain a constant engine speed for an extended time period during any portion of the break-in. Try to vary throttle position.

CYLINDER IDENTIFICATION

The four cylinders of this engine are identified as No. 1, No. 2, No. 3 and No. 4 cylinder, as counted from left to right (as viewed by the rider on the seat).

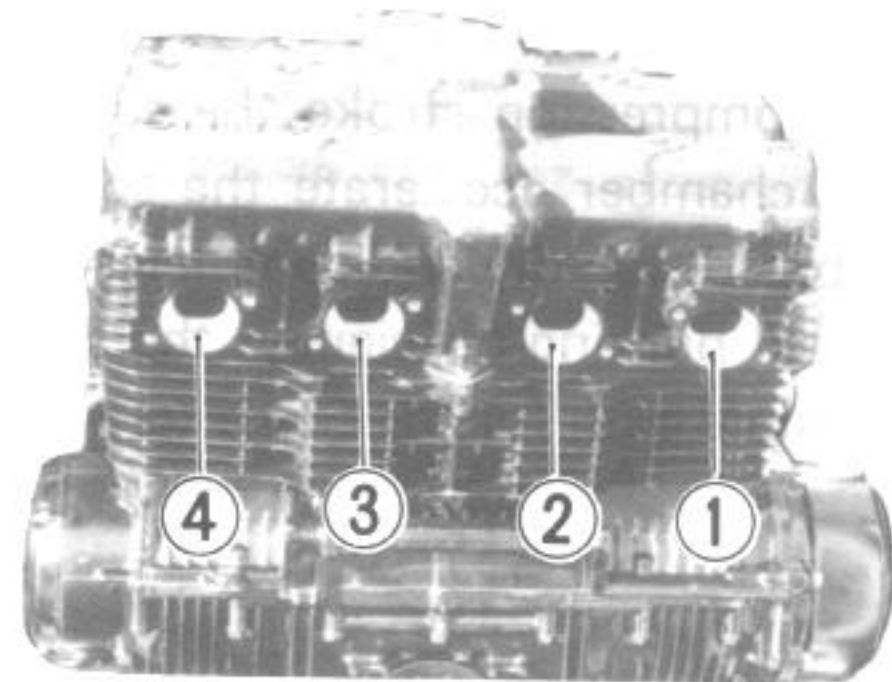

SPECIAL FEATURES

BLOWBY GAS RECYCLING

Blowby gases in the crankcase are constantly drawn into the chain chamber provided in the middle section of the cylinder block. The top section of this chamber is connected with the air chamber assembly through a rubber tube. In the air chamber, the gases merge with incoming air and thus are recycled to the engine through the normal intake system.

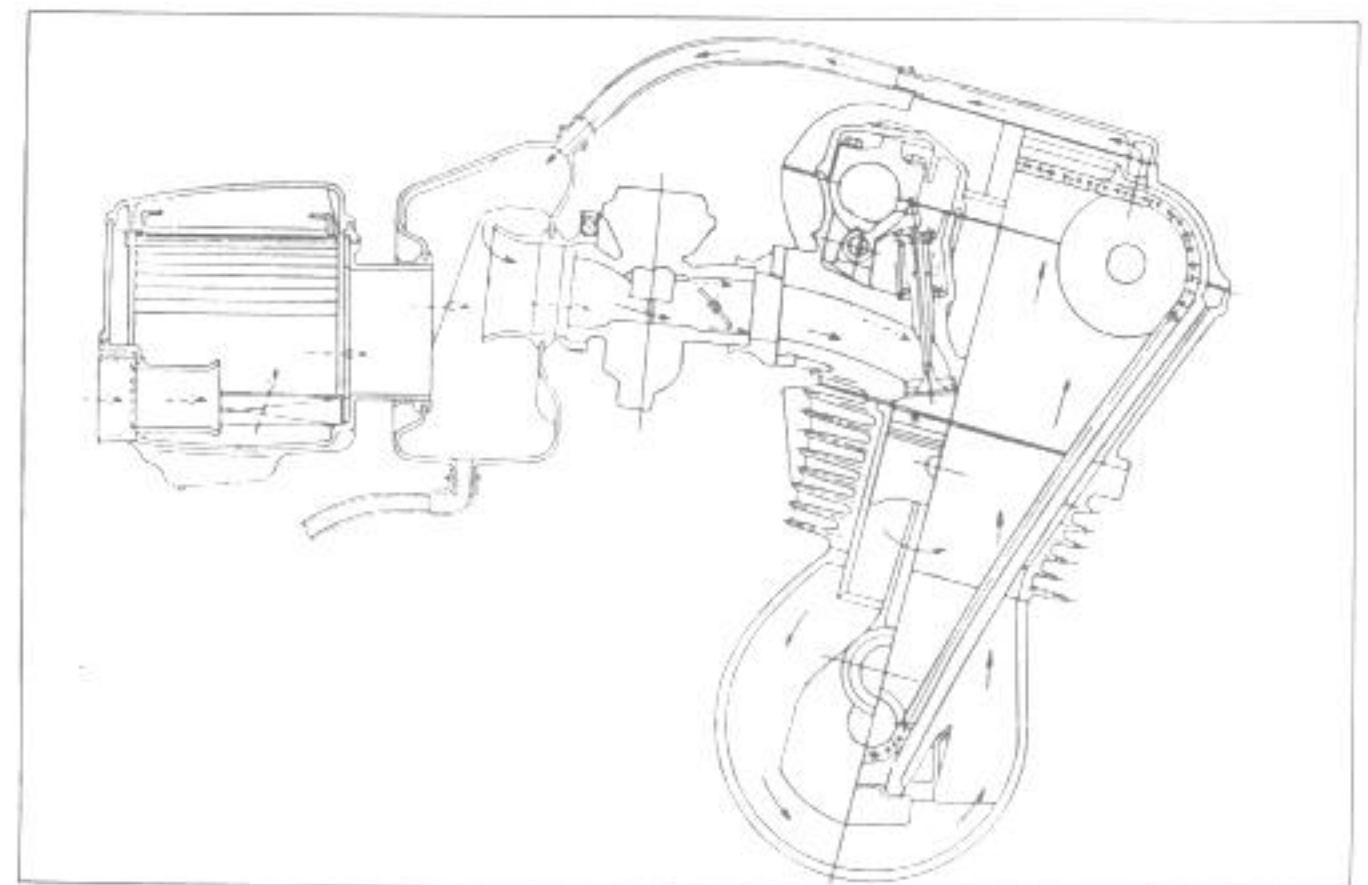

TSCC (TWIN SWIRL COMBUSTION CHAMBER)

SUZUKI has introduced a new breed of 4-valves-per-cylinder high-performance 4-stroke engines – the TSCC series. TSCC describes the heart of the engine, the Twin Swirl Combustion Chamber.

What the TSCC engine series does better than conventional 4-stroke engines, either 2-valve or 4-valve, is to improve on the two major factors which affect engine performance, charge burning efficiency and intake charging efficiency.

First, charge burning efficiency. The TSCC* system consists of a subtle, yet unique shape machined into the head. Each of the two intake valves is set into adjoining semi-hemispherical depressions in the head. During the intake stroke these depressions channel the incoming fuel/air mixture to form two separate high-speed swirls.

During the compression stroke the squish areas machined in the front and the rear of the cylinder head's combustion chamber accelerate the speed of the swirls. Thus, when the spark plug ignites the mixture, the flame spreads rapidly and completes the combustion more quickly.

To further aid burning efficiency, the spark plug is centrally located, the ideal location. This results in the shortest possible path for the flame to travel.

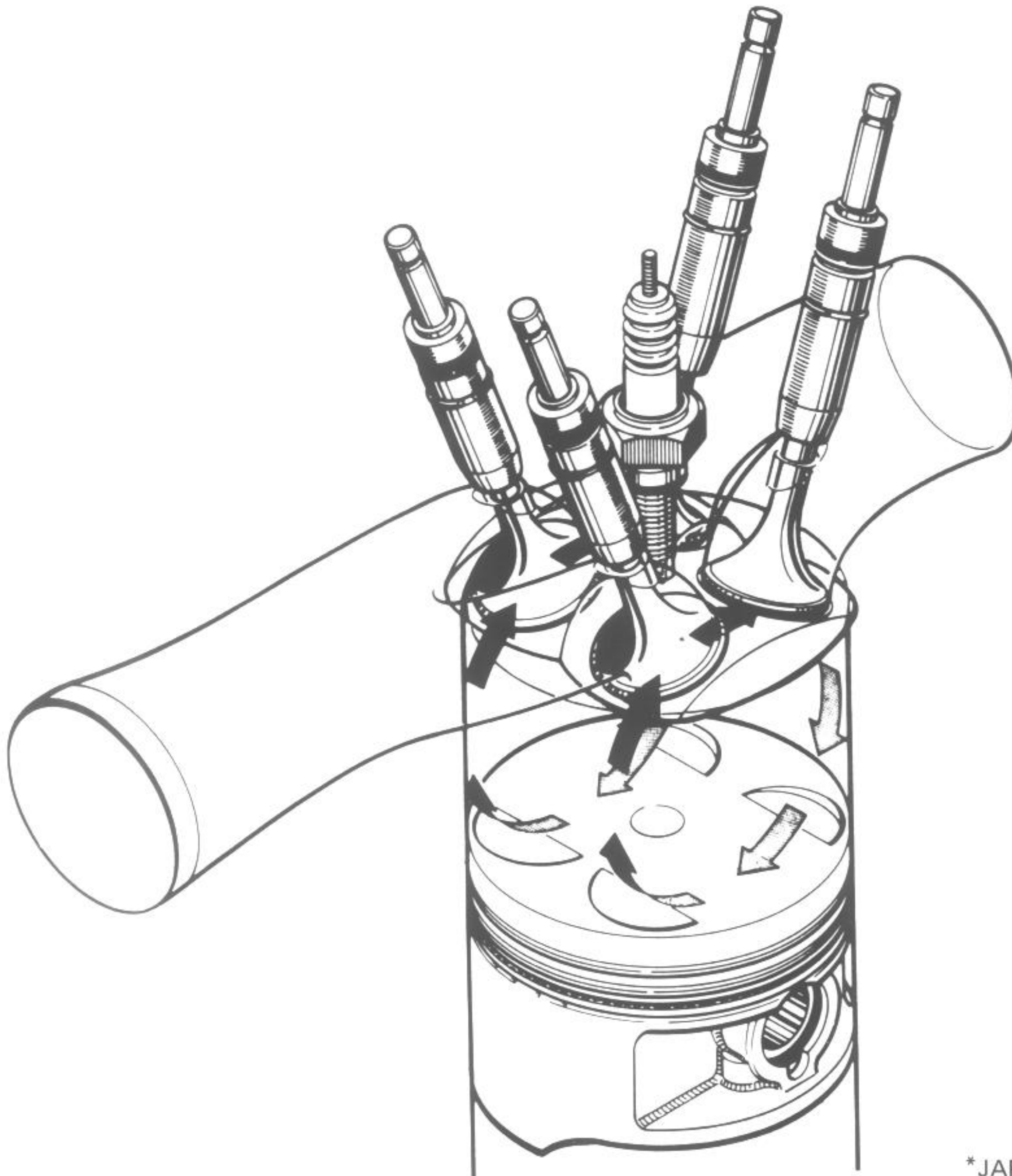

*JAPAN PATENT NO. 771502

The quick completion of burning results in more energy being developed while the piston is in position to transmit maximum power to the crankshaft.

High burning efficiency results in more power, improved throttle response at all rpm's, more complete combustion of the air/fuel mixture (cleaner combustion) and less chance of detonation.

Second, charging efficiency. The benefits of increased burning efficiency are further multiplied if intake charging efficiency is also increased. Basically, increasing the charging efficiency results in more fuel and air being drawn into the engine during each intake stroke. Thus, greater energy potential.

To achieve this, the four valve head was adopted. Two smaller diameter intake valves can flow more than one large valve. Additionally, two smaller valves run cooler due to increased valve seat area and two valve guides to increase heat transfer.

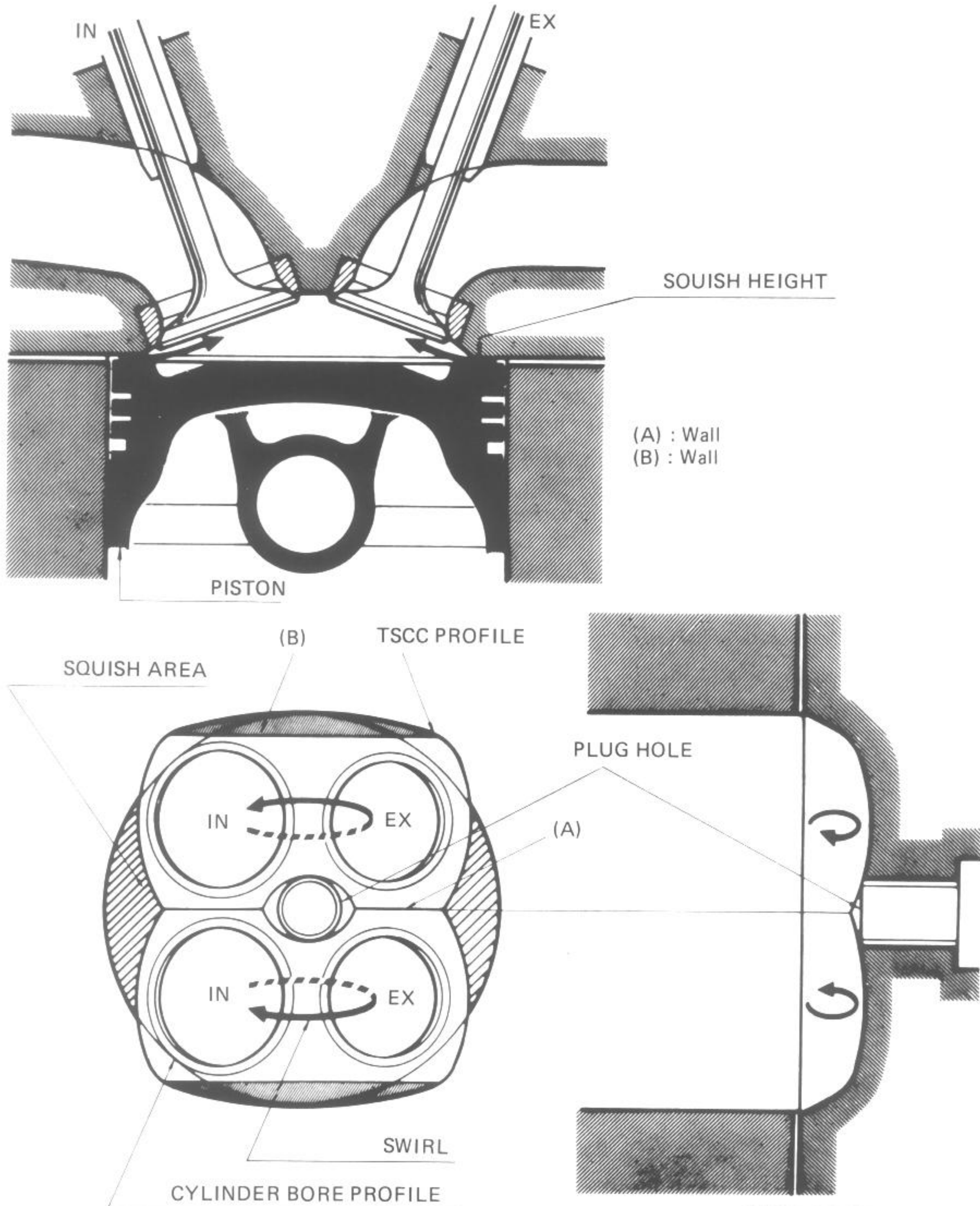

*JAPAN PATENT NO. 771502

But, SUZUKI went one step further. The valves are set in at a much shallower angle than other engines. The result is a smoother intake tract with less valve guide protrusion than in conventional cylinder heads. Therefore, increased flow, and smoother, less turbulent flow which contributes to more power and improved throttle response at all engine speeds.

There are several other benefits. This design is more efficient and will flow more air/fuel mixture than a conventional 4 valve head. Therefore, even smaller, lighter valves can be used with no decrease in power. Also, the valves can be shorter due to the placement angle. This allows more precise valve control since shorter, lighter valves are more easily controlled – especially at higher rpm's.

Yet another benefit of valves set at shallower angles is that the volume of the cylinder head combustion area is decreased. This allows the use of racing type flat-topped pistons since the desired compression ratio can be achieved without resorting to domed pistons. Flat topped pistons offer no restriction to the incoming air/fuel mixture and a flat-topped piston exposes the minimum amount of surface area to the hot burning mixture. This means that the flat piston absorbs less heat and therefore has to dissipate less heat through the rings and to the oil than a conventional domed piston. The result is a cooler running engine. Flat-topped pistons can also be made lighter resulting in less vibration and stress.

Increased burning efficiency. Increased charging efficiency. The result is more power throughout, from idle to redline. Throttle response is instant and clean. Displacement for displacement, no conventional engine, 2-valve or 4-valve, can compare. This could be enough, but SUZUKI went even further to ensure reliability and ease of maintenance.

A direct acting rocker arm is utilized to activate the valves. Each rocker arm, when depressed by the cam lobe, directly activates two valves at one time. With this system, engine height is reduced and tappets are not necessary. This system allows more room for cooling air flow and allows the use of larger valve springs which increases spring life by reducing stress. Valve adjustment is accomplished without special tools – quickly and easily.

Special sintered steel valve seats are incorporated, manufactured from premium alloys to ensure even more reliability under higher heat loads.

The patented TSCC combustion system combined with SUZUKI's high efficiency charging design results in power and throttle response found only in this new generation 4-stroke engine.

The SUZUKI TSCC engine series – performance without compromise.

The valve pitch (A) for TSCC and conventional are the same. Spring diameter (B) is larger than (C)

TSCC
4-valve

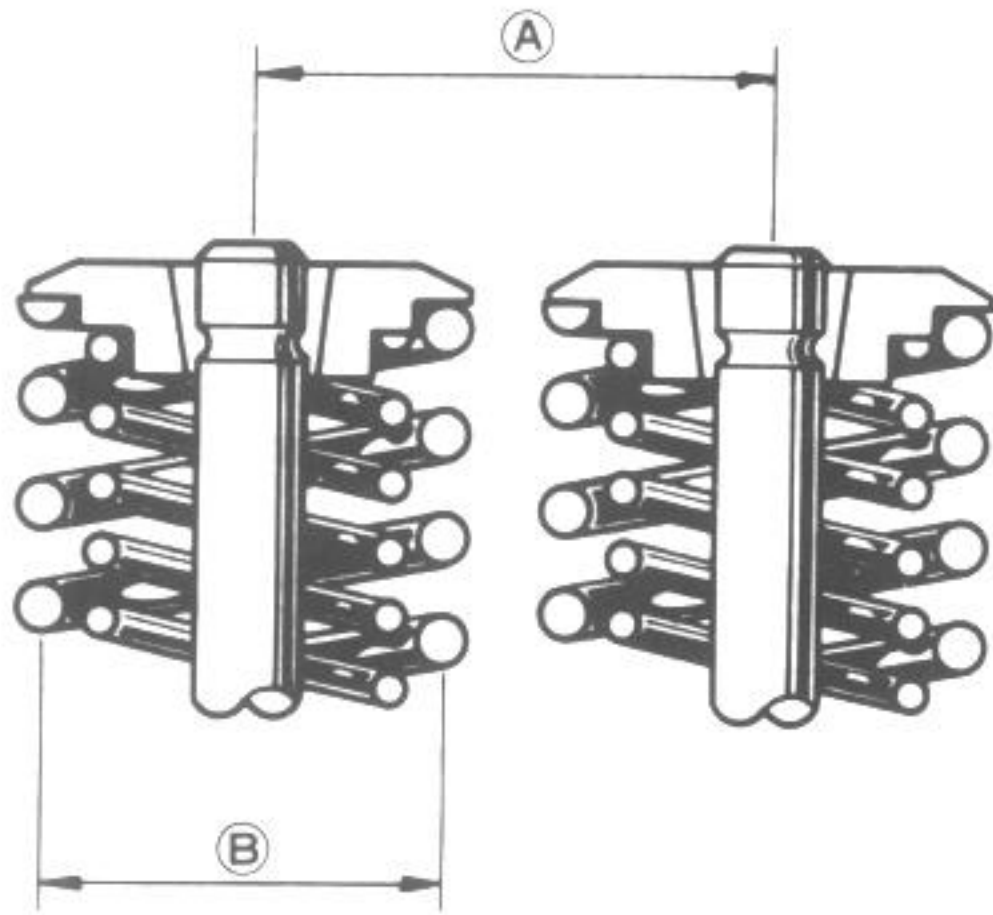

Conventional
4-valve

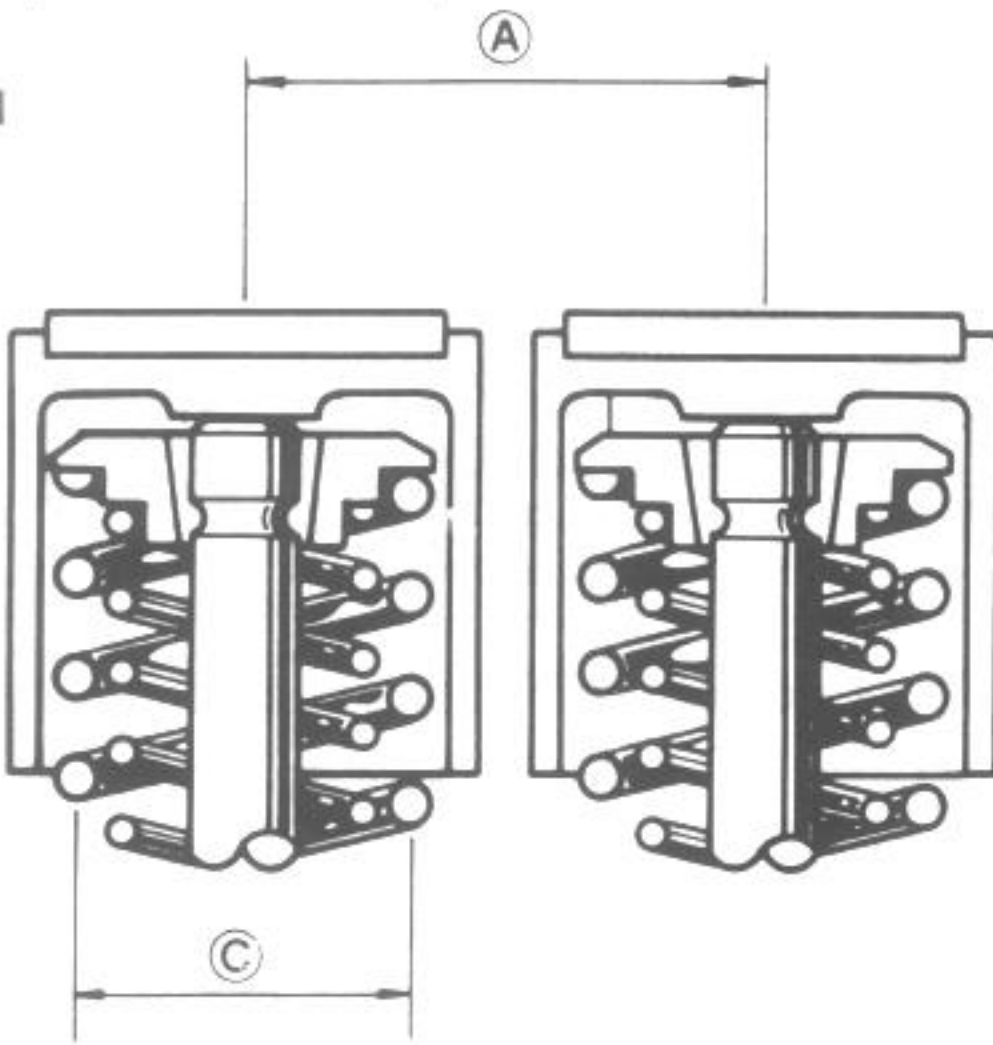

TSCC valve angle α is smaller than β .

TSCC
valve angle

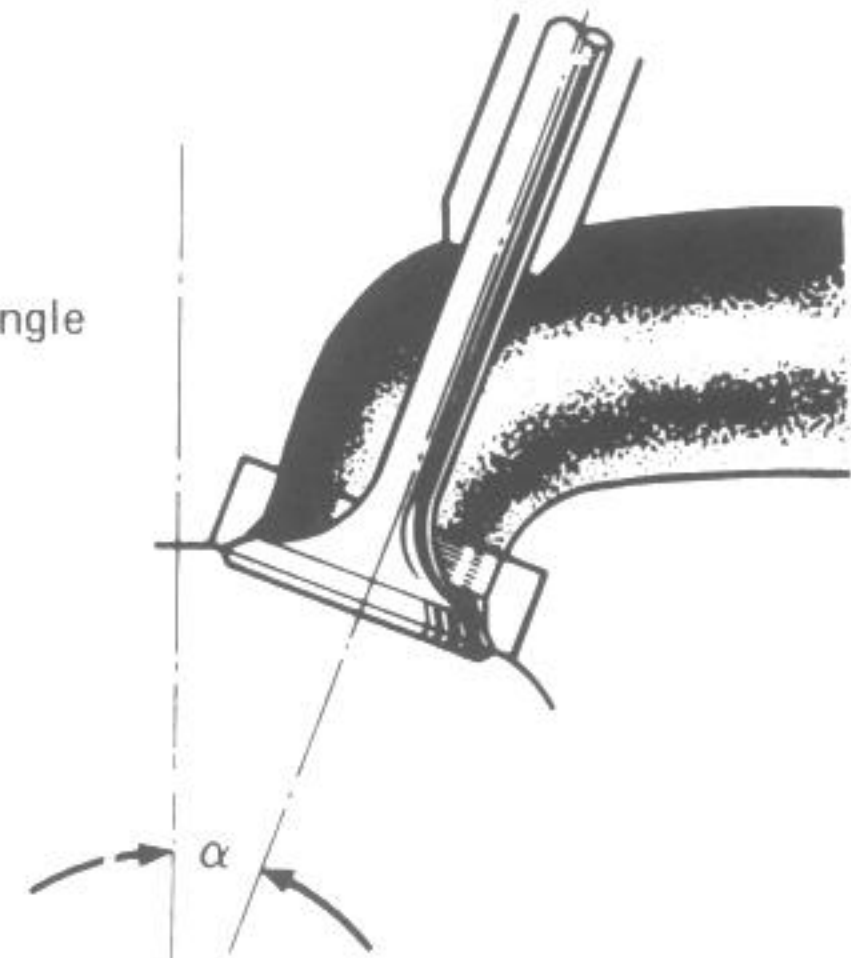

Conventional
valve angle

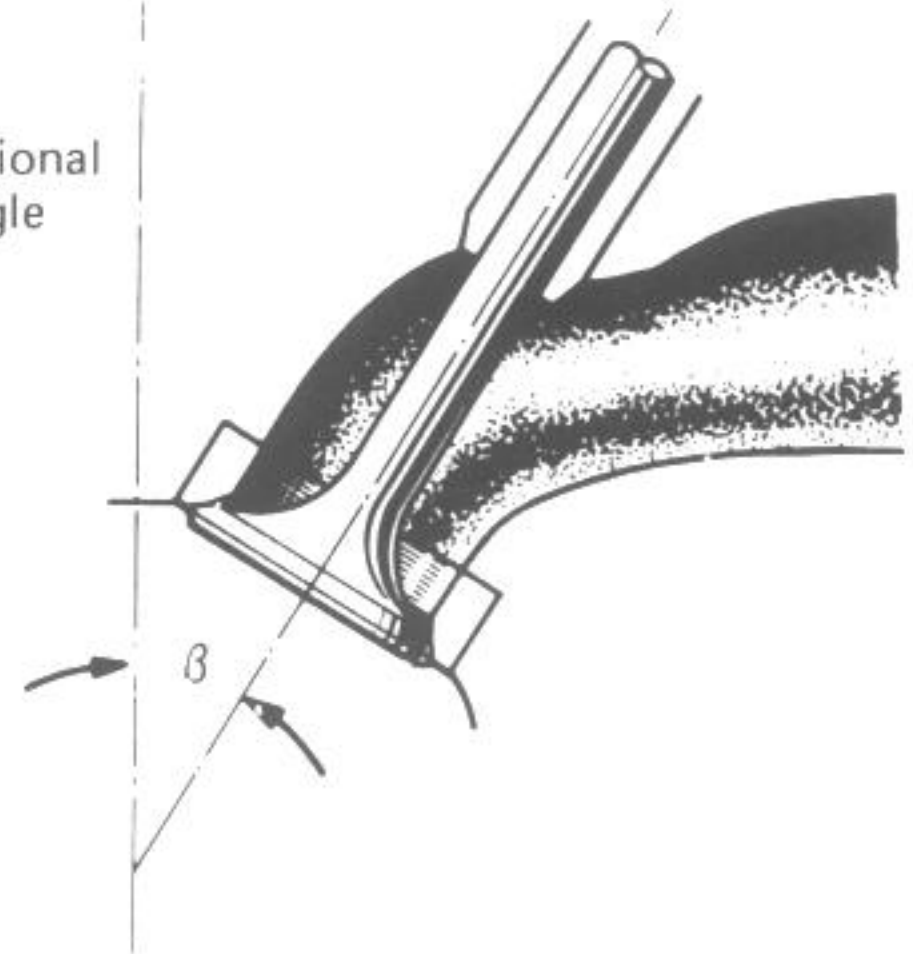

*JAPAN PATENT NO. 771502

PRECAUTIONS AND GENERAL INSTRUCTIONS

Observe the following items without fail when disassembling and reassembling motorcycles.

- Do not run engine indoors with little or no ventilation.
- Be sure to replace packings, gaskets, circlips, O-rings and cotter pins with new ones.

CAUTION:

Never reuse a circlip after a circlip has been removed from a shaft, it should be discarded and a new circlip must be installed.

When installing a new circlip, care must be taken not to expand the end gap larger than required to slip the circlip over the shaft.

After installing a circlip, always insure that it is completely seated in its groove and securely fitted.

- Tighten cylinder head and case bolts and nuts beginning with larger diameter and ending with smaller diameter, and from inside to out-side diagonally, to the specified tightening torque.
- Use special tools where specified.
- Use genuine parts and recommended oils.
- When 2 or more persons works together, pay attention to the safety of each other.
- After the reassembly, check parts for tightness and operation.
- Treat gasoline, which is extremely flammable and highly explosive, with greatest care. Never use gasoline as cleaning solvent.

Warning, Caution and Note are included in this manual occasionally, describing the following contents.

- WARNING** The personal safety of the rider or bystanders may be involved. Disregarding this information could result in personal injury.
- CAUTION** These instructions point out special service procedures or precautions that must be followed to avoid damaging the machine.
- NOTE**..... This provides special information to make maintenance easier or important instructions clearer.

REPLACEMENT PARTS

When you replace any parts, use only genuine SUZUKI replacement parts, or their equivalent. Genuine SUZUKI parts are high quality parts which are desined and built specifically for SUZUKI vehicles.



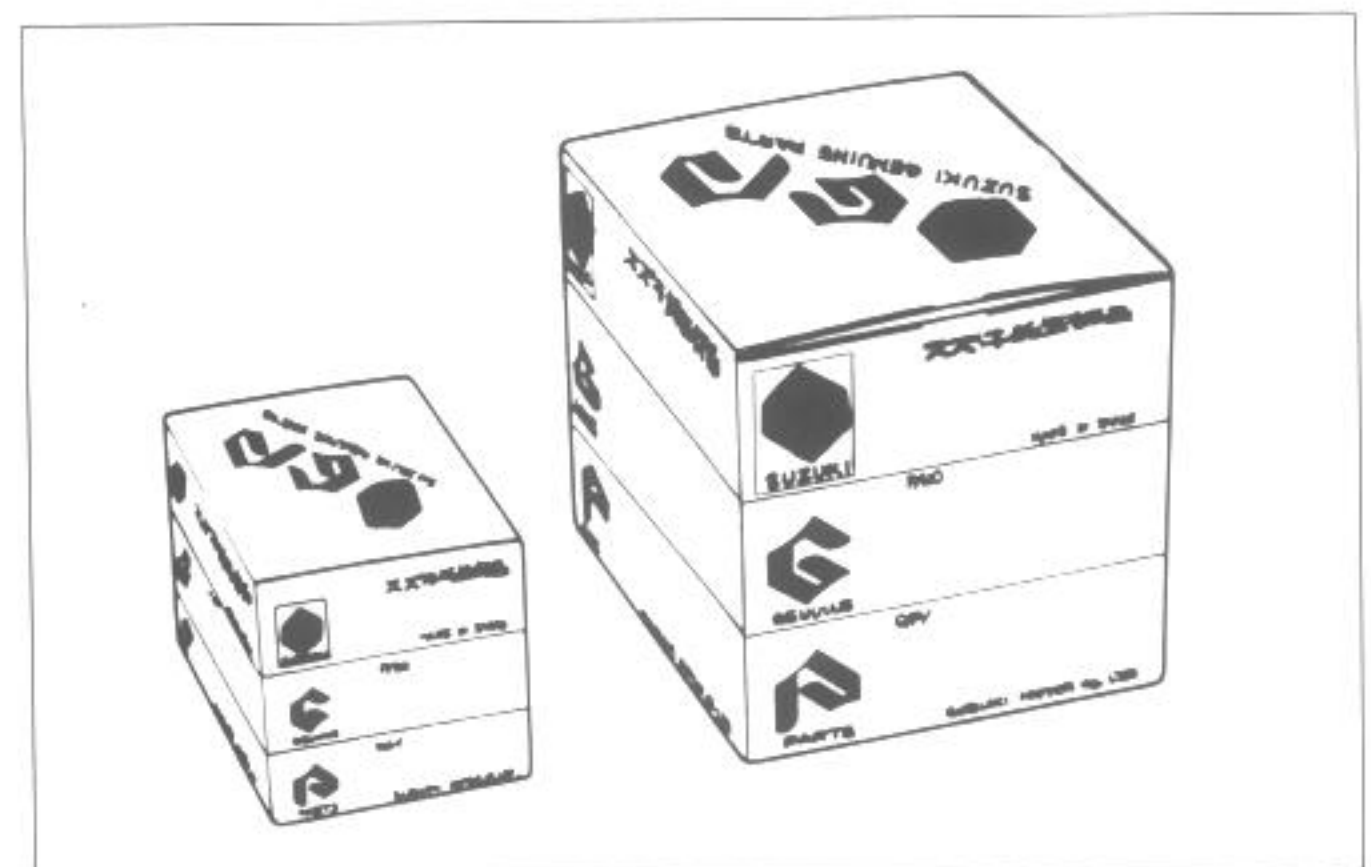

CAUTION:





Use of replacement parts which are not equivalent in quality to genuine SUZUKI parts can lead to performance problems and damage.

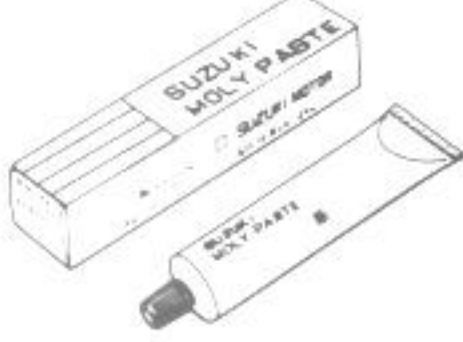

SPECIAL MATERIALS

The materials listed below are needed for maintenance work on the GSX1100E, and should be kept on hand for ready use. They supplement such standard materials as cleaning fluids, lubricants, emery cloth and the like. How to use them and where to use them are described in the text of this manual.

MATERIAL	PART	PAGE	PART	PAGE
 SUZUKI BRAKE FLUID 99000-23021 (0.5L)	<ul style="list-style-type: none"> ● Brake fluid (front and rear) 	2-18		
 SUZUKI SUPER GREASE "A" 99000-25010	<ul style="list-style-type: none"> ● Oil seals ● Carburetor starter shaft ● Wheel bearings ● Speedometer gear box ● Steering stem bearing ● Throttle grip and cable ● Front brake light switch contact ● Center stand ● Side stand ● Rear torque link spacer 	3-47 4-13 6-4 6-40 6-5 6-27	<ul style="list-style-type: none"> ● Rear brake pedal shaft ● Cushion lever needle bearing ● Cushion rod needle bearing ● Dust seals ● Rear swing arm bearing ● Spacers ● Rear shock absorber damping adjuster gear 	6-34 6-55 6-55 6-55 6-56 6-56 6-57 6-57 6-58
 SUZUKI FORK OIL #15 99000-99044-15G	<ul style="list-style-type: none"> ● Front fork 	2-23 6-21		
 SUZUKI MOLY PASTE 99000-25140	<ul style="list-style-type: none"> ● Valve stem ● Cam shaft journal ● Chain tensioner adjuster shaft ● Drive shaft 	3-28 3-64 3-34 3-46		
 SUZUKI BOND NO. 1207B 99000-31140	<ul style="list-style-type: none"> ● Cylinder head cover ● Mating surface of lower crankcase ● Mating surface of crankcase and clutch cover, generator cover ● Cylinder stud bolt ● Cylinder head gasket 	2-5 3-70 3-51 3-54 3-58 3-48 3-70	<ul style="list-style-type: none"> ● Front fork damper rod bolt ● Engine oil temperature gauge 	6-20

MATERIAL	PART	PAGE	PART	PAGE
 <p>THREAD LOCK SUPER "1333B" 99000-32020</p>	<ul style="list-style-type: none"> ● Cam chain guide holder screw ● Cam chain guide bolt ● Cam chain guide screw 	<p>3-51 3-59 3-35</p>		
 <p>THREAD LOCK SUPER "1303B" 99000-32030</p>	<ul style="list-style-type: none"> ● Cam sprocket allen bolt ● Starter clutch allen bolt ● Oil pump case securing screw ● Throttle valve screw 	<p>3-31 3-42 3-43</p>		
 <p>THREAD LOCK CEMENT 99000-32040</p>	<ul style="list-style-type: none"> ● Oil filter cap nut ● Carburetor lower bracket screw ● Carburetor upper bracket screw ● Carburetor starter shaft lock screw ● Front fork damper rod bolt 	<p>2-14 3-69 4-13 4-13 4-14 6-20</p>		
 <p>THREAD LOCK "1342" 99000-32050</p>	<ul style="list-style-type: none"> ● Generator stator securing screw ● Generator stator lead wire screw ● Gearshift cam pawl screw ● Gearshift cam guide screw ● Engine oil sump filter screw ● Starter motor securing bolt ● Drive shaft plate screw ● Countershaft B/g retainer screw ● Oil gallery plate screw 	<p>3-42 3-42 3-49 3-49 3-49 3-55 5-11 3-55 3-55 3-55</p>	<ul style="list-style-type: none"> ● Engine oil pump set screw ● Posi-damp unit bolt 	<p>3-55 6-20</p>
 <p>THREAD LOCK SUPER "1305" 99000-32100</p>	<ul style="list-style-type: none"> ● Countershaft 2nd drive gear ● Generator rotor nut 	<p>3-44 3-53</p>		
<p>THREAD LOCK "1360" 99000-32130</p>	<ul style="list-style-type: none"> ● Disc plate bolt 	<p>6-5</p>		

SPECIFICATIONS

DIMENSIONS AND DRY MASS

Overall length	2 240 mm
Overall width	815 mm
Overall height	1 140 mm
Wheelbase	1 550 mm
Ground clearance	155 mm
Seat height	785 mm
Dry mass	232 kg

ENGINE

Type	Four-stroke, air-cooled, DOHC
Number of cylinders	4
Bore	74.0 mm
Stroke	66.0 mm
Piston displacement	1 135 cm ³
Compression ratio	9.7 : 1
Carburetor	MIKUNI BS36SS, four
Air cleaner	Paper element
Starter system	Electric
Lubrication system	Wet sump

TRANSMISSION

Clutch	Wet multi-plate type
Transmission	5-speed constant mesh
Gearshift pattern	1-down, 4-up
Primary reduction	1.780 (89/50)
Final reduction	2.800 (42/15)
Gear ratios, Low	2.500 (35/14)
2nd	1.777 (32/18)
3rd	1.380 (29/21)
4th	1.125 (27/24)
Top	0.961 (25/26)
Drive chain	DAIDO D.I.D. 630YL or TAKASAGO RK630GSV, 102 links

CHASSIS

Front suspension	Posi Damp Fork system, telescopic, coil spring 4-way adjustable, damper 4-way adjustable. Posi Damp Fork system, telescopic, pneumatic/coil spring 4-way adjustable, damper 4-way adjustable . . . For Canada
Rear suspension	Full-floating suspension system, spring 5-way adjustable, damper 4-way adjustable
Steering angle	35° (right and left)
Caster	62°00'
Trail	117 mm
Turning radius	3.1 m
Front brake	Disc brake, twin
Rear brake	Disc brake

Front tire size	110/90 V16
Rear tire size	130/90 V17
Front fork stroke	150 mm
Rear wheel travel	115 mm
Front tire pressure	250 kPa (2.50 kg/cm ²) (Normal solo riding)
Rear tire pressure	250 kPa (2.50 kg/cm ²) (Normal solo riding)

ELECTRICAL

Ignition type	Transistorized
Ignition timing	10° B.T.D.C. below 1 500 r/min and 32° B.T.D.C. above 3 500 r/min
Spark plug	NGK D9EA or NIPPON DENSO X27ES-U (E-01, 24, 25, 27, 34) NGK DR8ES or NIPPON DENSO X27ESR-U (The Others)
Battery	12V 50.4 kC (14 Ah)/10 HR
Generator	Three-phase A.C. generator
Fuse	10/10/10/10/15A

CAPACITIES

Fuel tank including reserve	20.0 L
reserve	4.9 L
Engine oil	3 200 ml
Front fork oil	268 ml 286 ml (For Canada)

* Specifications subject to change without notice.

PERIODIC MAINTENANCE AND TUNE-UP PROCEDURES

CONTENTS

<i>PERIODIC MAINTENANCE SCHEDULE</i>	2- 1
<i>PERIODIC MAINTENANCE CHART</i>	2- 1
<i>LUBRICATION CHART</i>	2- 2
<i>MAINTENANCE AND TUNE-UP PROCEDURES</i>	2- 3
<i>AIR CLEANER</i>	2- 3
<i>BATTERY</i>	2- 4
<i>CYLINDER HEAD NUTS AND EXHAUST PIPE BOLTS</i>	2- 5
<i>VALVE CLEARANCE</i>	2- 6
<i>COMPRESSION CHECK</i>	2- 7
<i>SPARK PLUG</i>	2- 9
<i>CARBURETOR</i>	2-10
<i>FUEL LINE</i>	2-13
<i>ENGINE OIL AND OIL FILTER</i>	2-14
<i>OIL SUMP FILTER</i>	2-15
<i>OIL PRESSURE</i>	2-15
<i>CLUTCH</i>	2-16
<i>DRIVE CHAIN</i>	2-16
<i>BRAKES</i>	2-18
<i>TIRES</i>	2-21
<i>STEERING</i>	2-22
<i>FRONT FORK</i>	2-23
<i>CHASSIS BOLTS AND NUTS</i>	2-24

PERIODIC MAINTENANCE SCHEDULE

The chart below lists the recommended intervals for all the required periodic service work necessary to keep the motorcycle operating at peak performance and economy. Traveling distances are expressed in terms of kilometers and miles.

NOTE:

More frequent servicing may be performed on motorcycles that are used under severe conditions.

PERIODIC MAINTENANCE CHART

ENGINE

Item	Interval	Initial 1 000 km (600 miles)	Every 5 000 km (3 000 miles)	Every 10 000 km (6 000 miles)	Page
Air cleaner		Clean every 3 000 km (2 000 miles), and replace every 12 000 km (8 000 miles)			2-3
Battery		Inspect	Inspect	—	2-4
Cylinder head nuts and exhaust pipe bolts		Inspect	Inspect	—	2-5
Valve clearance		Inspect	Inspect	—	2-6
Compression		Inspect	Inspect	—	2-7
Spark plugs		Inspect	Inspect	Replace	2-9
Carburetor		Inspect	Inspect	—	2-10
Fuel lines		Inspect	Inspect	—	2-13
		Replace every 4 years			
Engine oil		Change	Change	—	2-14
Engine oil filter		Replace	Replace	—	2-14
Oil sump filter		—	—	Clean	2-15
Oil pressure		—	Inspect	—	2-15
Clutch		Inspect	Inspect	—	2-16

CHASSIS

Item	Interval	Initial 1 000 km (600 miles)	Every 5 000 km (3 000 miles)	Every 10 000 km (6 000 miles)	Page
Drive chain		Inspect and clean every 1 000 km (600 miles)			2-16
Brakes		Inspect	Inspect	—	2-18
Brake hoses		Inspect	Inspect	—	2-18
		Replace every 4 years			
Brake fluid		Change every 2 years			2-18
Tires		Inspect	Inspect	—	2-21
Steering		Inspect	Inspect	—	2-22
Front fork oil		Change	—	Change	2-23
Front fork air (For Canada)		Inspect every 5 000 km (3 000 miles) or 6 months			2-23

LUBRICATION CHART

The maintenance schedule, which follows, is based on odometer indication and is calculated to achieve the ultimate goal of motorcycle maintenance in the most economical manner.

Item \ Interval	Initial and every 5 000 km (3 000 miles)	Every 10 000 km (6 000 miles)
Throttle cable	Motor oil	—
Throttle grip	—	Grease
Clutch cable	Motor oil	—
Starter cable	Motor oil	—
Speedometer cable	—	Grease
Drive chain	Motor oil every 1 000 km (600 miles)	
Brake pedal shaft	Grease or oil	—
Steering stem bearings	Grease every 2 years or 20 000 km (12 000 miles)	
Swing arm bearings		
Side stand		
Center stand		
Cushion rod bearing		
Cushion lever bearing		
Rear torque link spacer		

NOTE:

- * Lubricate exposed parts which are subject to rust with either motor oil or grease whenever the motorcycle has been operated under wet or rainy conditions.
- * Before lubricating each part, clean off any rusty spots and wipe off any grease, oil, dirt or grime.

MAINTENANCE AND TUNE-UP PROCEDURES

This section describes the service procedures for each section of the Periodic Maintenance requirements.

AIR CLEANER

Clean Every 3 000 km (2 000 mi), and
Replace Every 12 000 km (8 000 mi).

- Remove the seat and fuel tank and remove the air cleaner case cover by unscrewing the fixing screws. Take out the air cleaner element.
- Carefully use an air hose to blow the dust from the cleaner element inside.

CAUTION:

Always use air pressure on the inside of the cleaner element. If air pressure is used on the outside dirt will be forced into the pores of the cleaner element thus restricting air flow through the cleaner element.

- Reinstall the cleaned or new cleaner element in the reverse order of removal. Make sure that the element is properly seated to the cleaner case.

CAUTION:

If driving under dusty conditions, clean the air cleaner element more frequently. The surest way to accelerate engine wear is to run the engine without the element or to use a ruptured element. Make sure that the air cleaner is in good condition at all times. Life of the engine depends largely on this component!

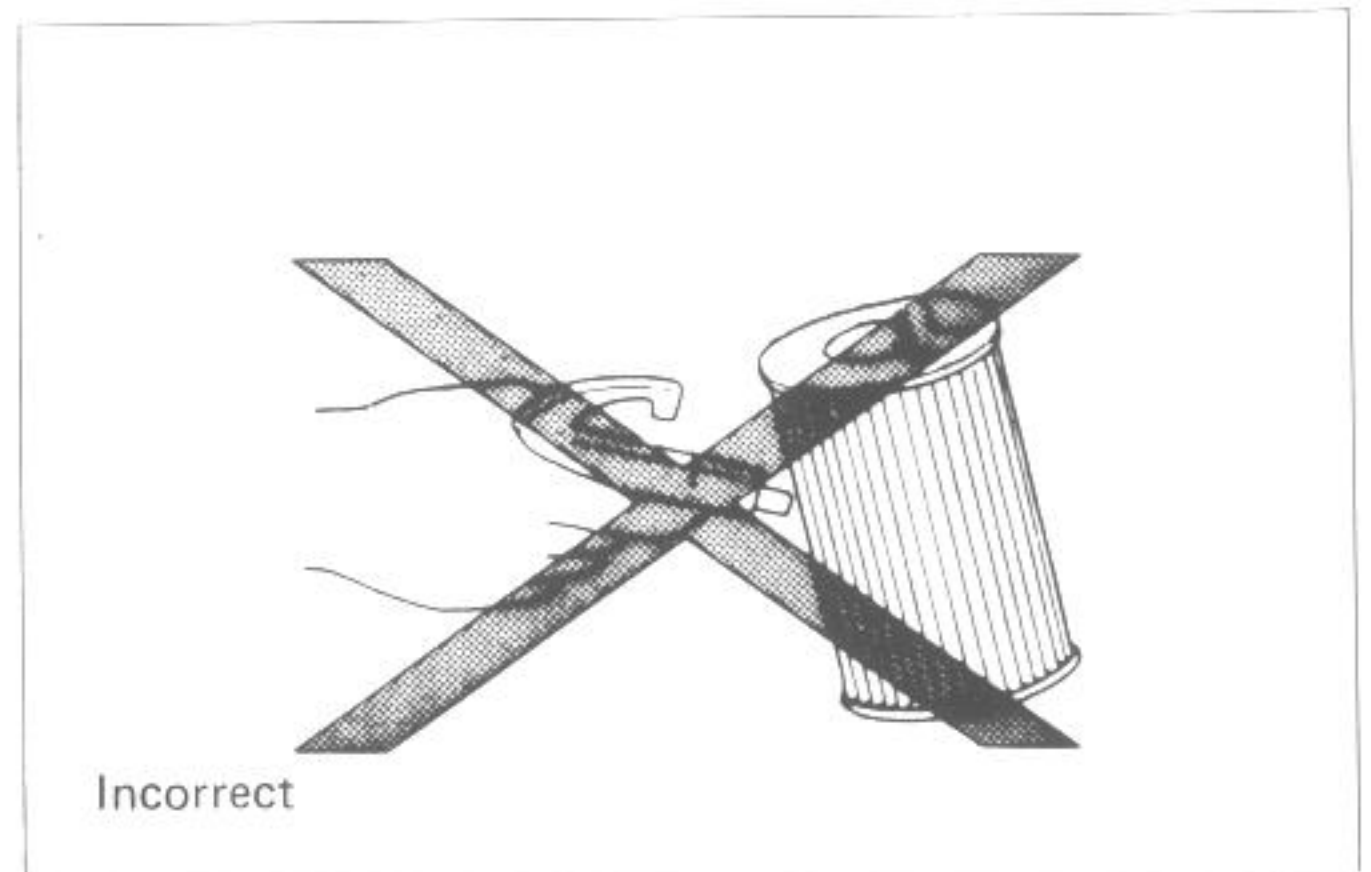
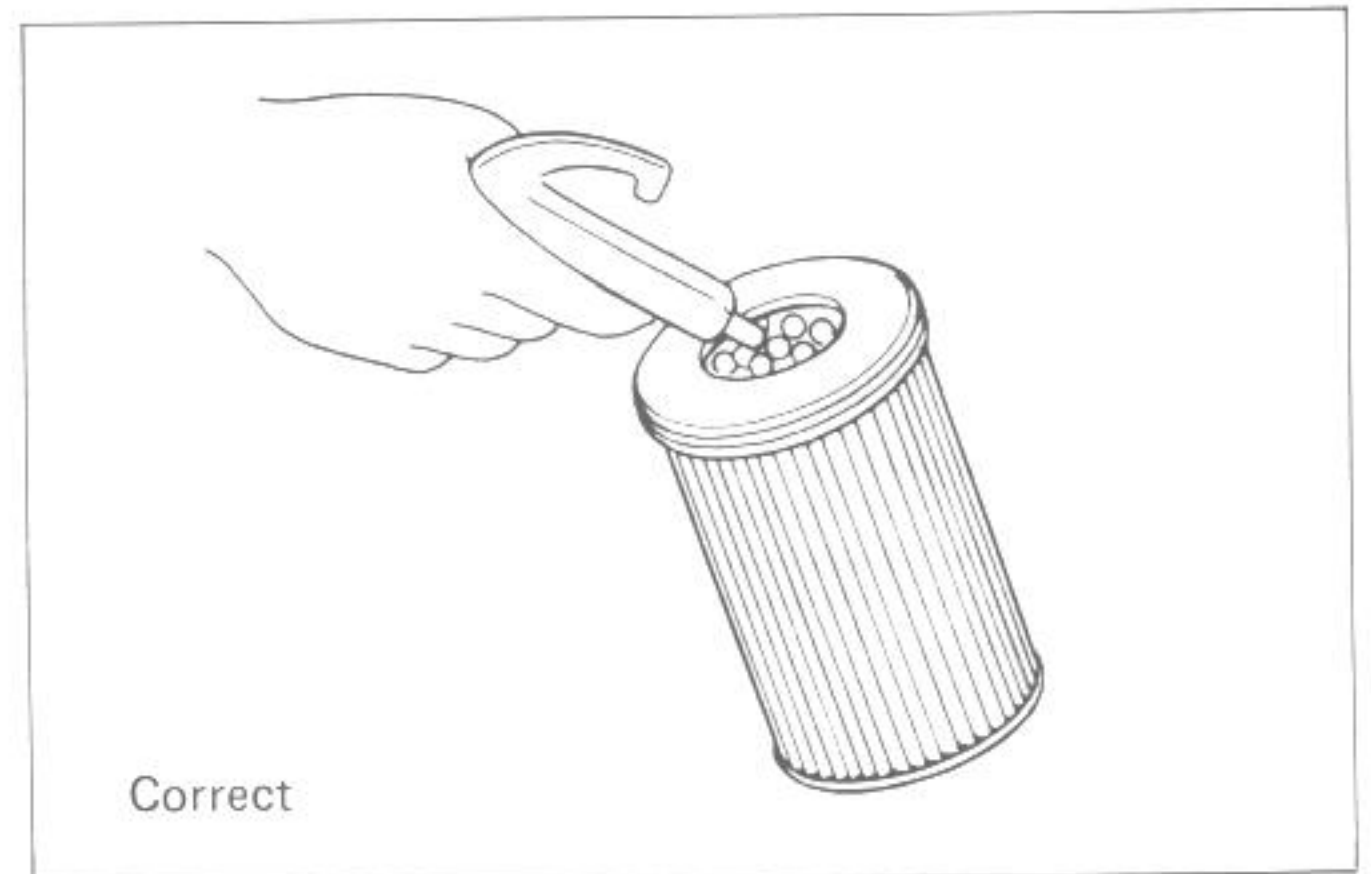
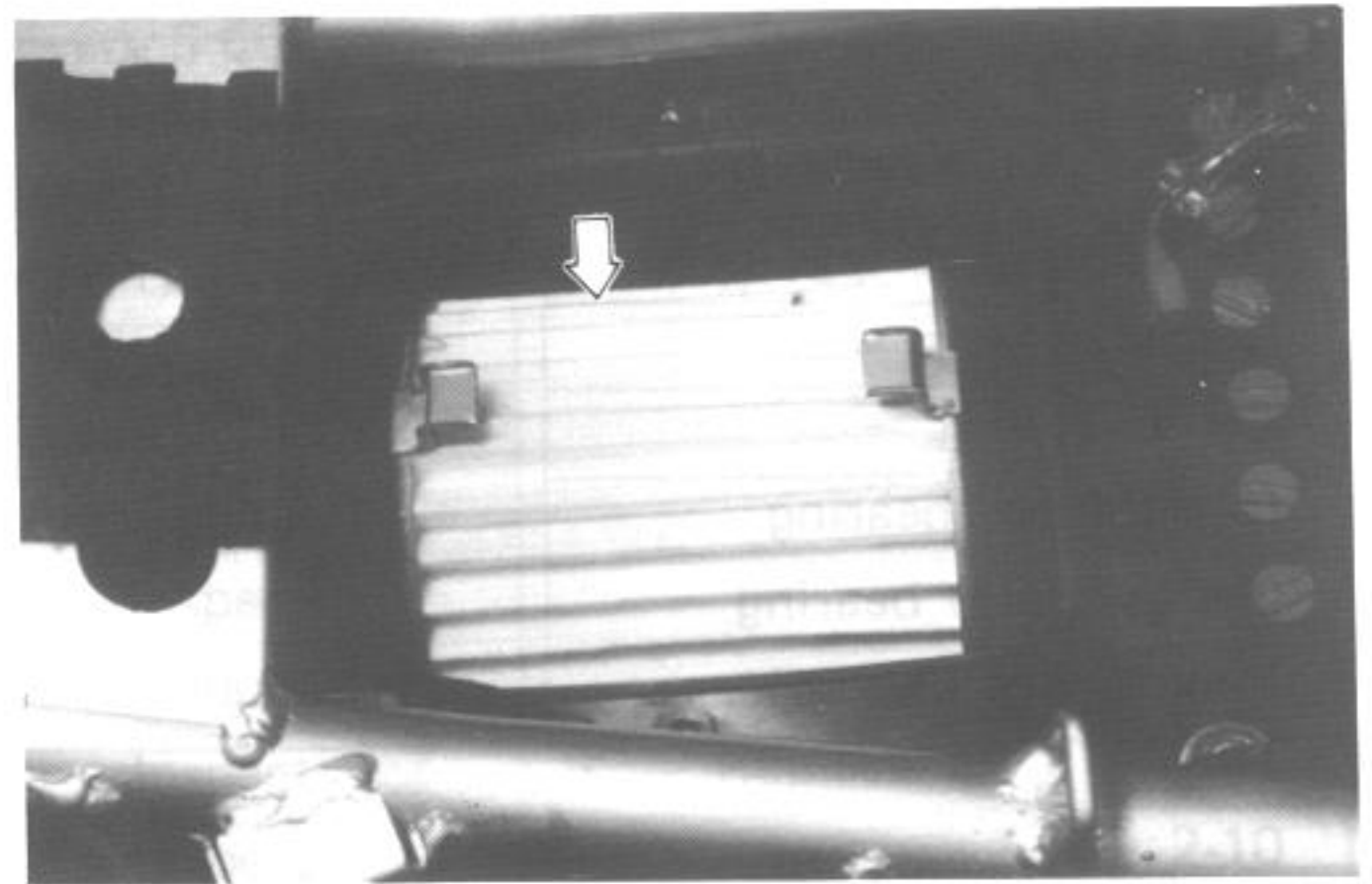
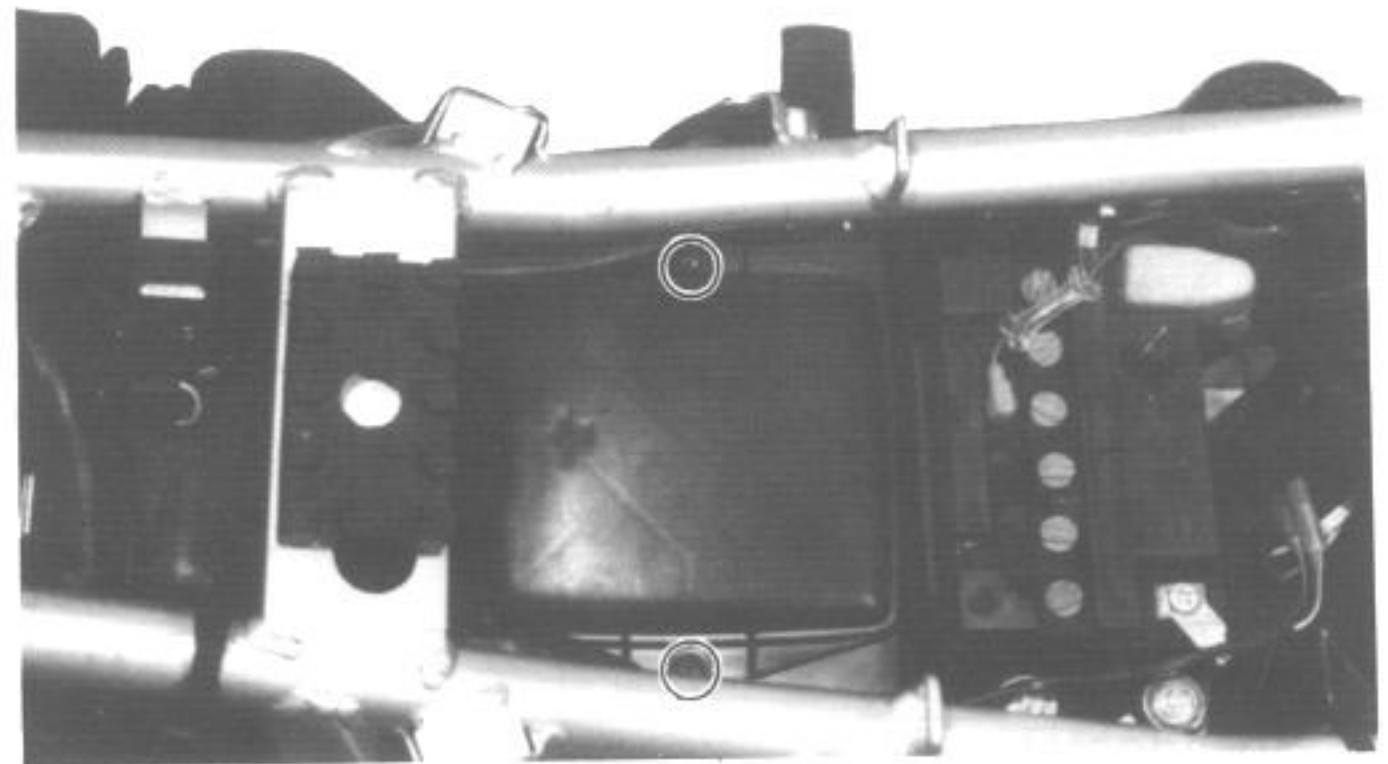

BATTERY

Check Initial 1 000 km (600 mi) and Every 5 000 km (3 000 mi).

- Remove the seat.
- Check electrolyte for level and specific gravity. Add distilled water, as necessary to keep the surface of the electrolyte above the MIN. level line but not above the MAX. level line.
- For checking specific gravity, use a hydrometer to determine the charge condition.

09900-28403	Hydrometer
-------------	------------

Standard specific gravity	1.28 at 20°C
---------------------------	--------------

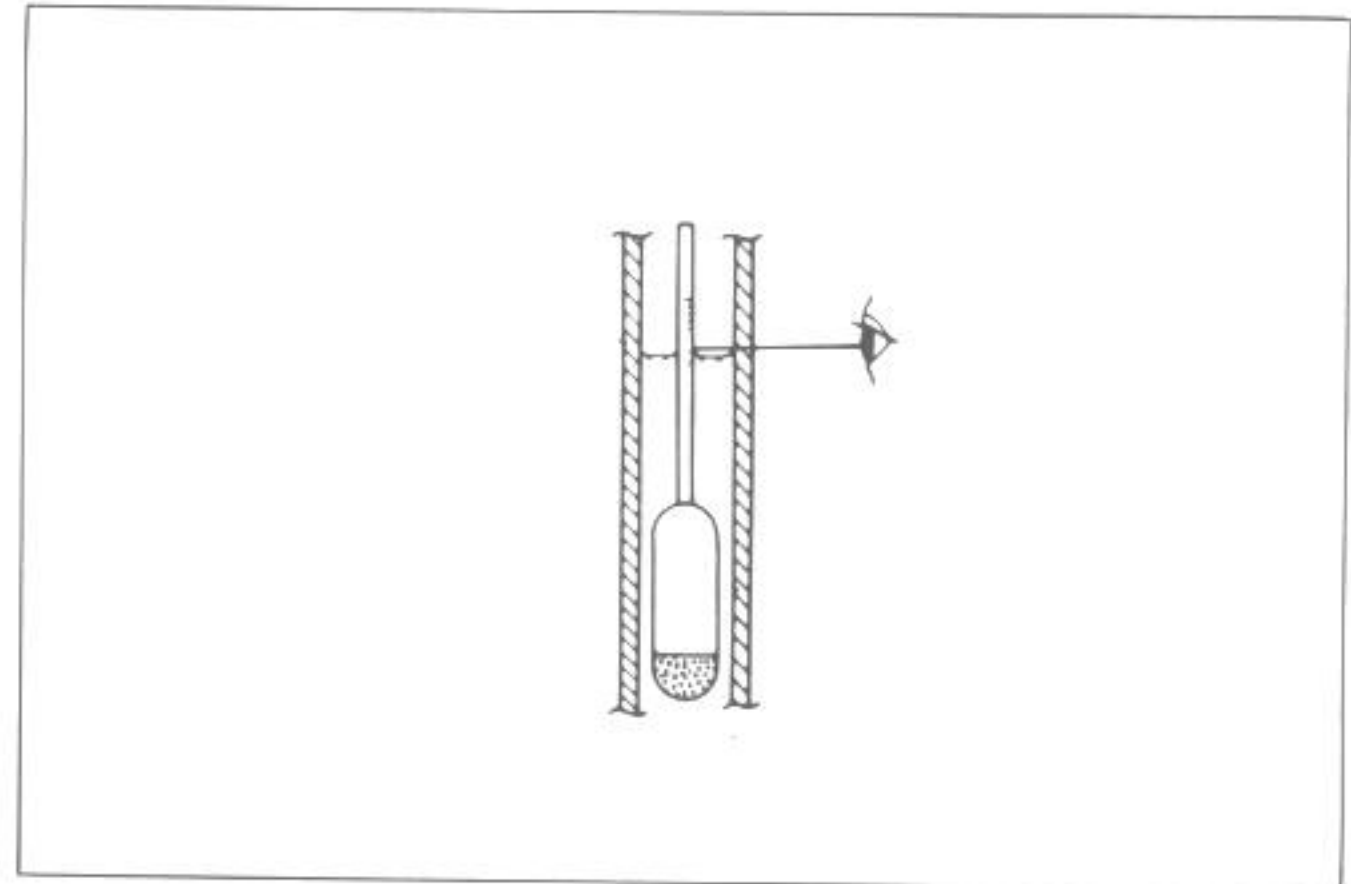
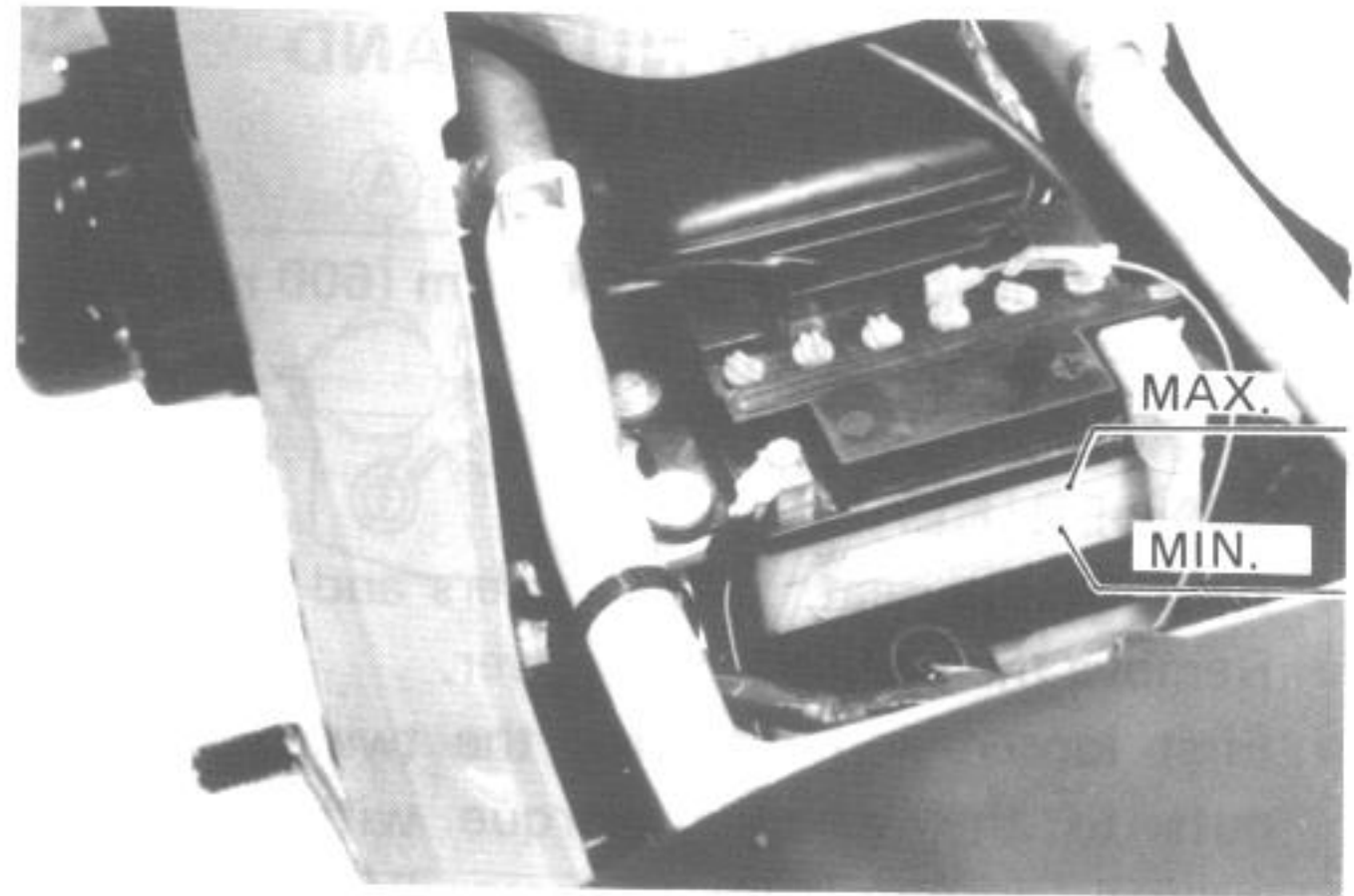

An S.G. reading of 1.22 (at 20°C) or under means that the battery needs recharging. Remove the battery from the machine and charge it with a battery charger.

CAUTION:

- * Never charge a battery while still in the machine as damage may result to the battery or regulator/rectifier.
 - * Be careful not to bend, obstruct, or change the routing of the vent tube from the battery, make certain that the vent tube is attached to the battery vent fitting and that the opposite end is always open.
- Remove the right frame cover.
 - Check that the vent pipe is tightly secured and undamaged, and is routed as shown.



CYLINDER HEAD NUTS AND EXHAUST PIPE BOLTS

Inspect (Tighten) Initial 1 000 km (600 mi) and Every 5 000 km (3 000 mi).

CYLINDER HEAD

- Remove the seat, frame covers and fuel tank.
- Remove the cylinder head cover.
- First loosen and retighten the twelve 10 mm nuts to the specified torque with a torque wrench sequentially in ascending numerical order with the engine cold.

Cylinder head nut	35 – 40 N·m (3.5 – 4.0 kg-m)
-------------------	---------------------------------

- After firmly tightening the 12 nuts, tighten one 6 mm bolt (indicated as **A** to the torque value below):

Cylinder head bolt A	7 – 11 N·m (0.7 – 1.1 kg-m)
-----------------------------	--------------------------------

- When installing the cylinder head cover, apply SUZUKI Bond No. 1207B to the head cover groove and cam end caps. (Refer to page 3-70).

99000-31140	SUZUKI Bond No. 1207B
-------------	-----------------------

EXHAUST PIPE

- Tighten the exhaust pipe clamp bolts to the specified torque with a torque wrench.

Exhaust pipe clamp bolt	20 – 25 N·m (2.0 – 2.5 kg-m)
-------------------------	---------------------------------

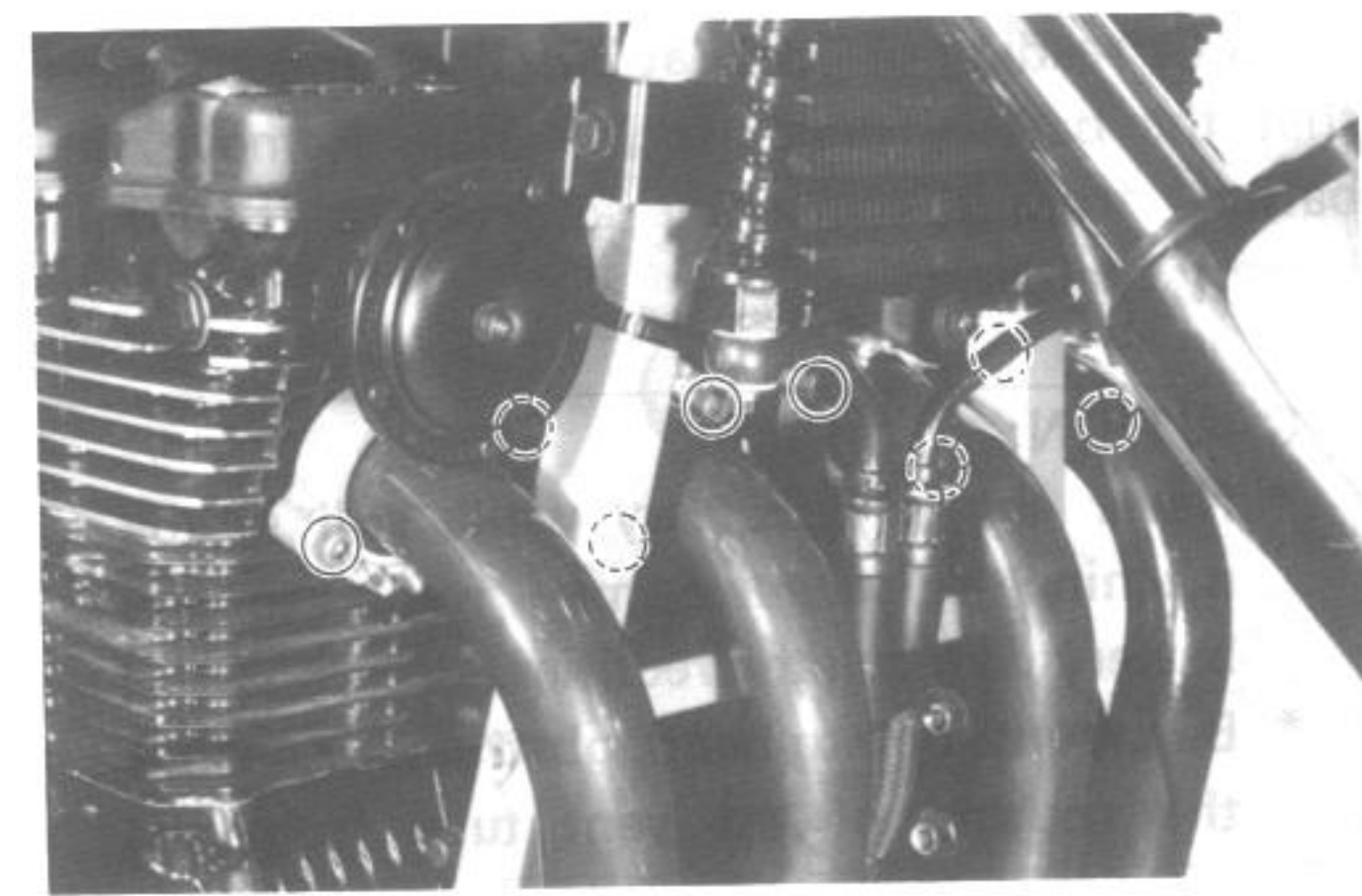
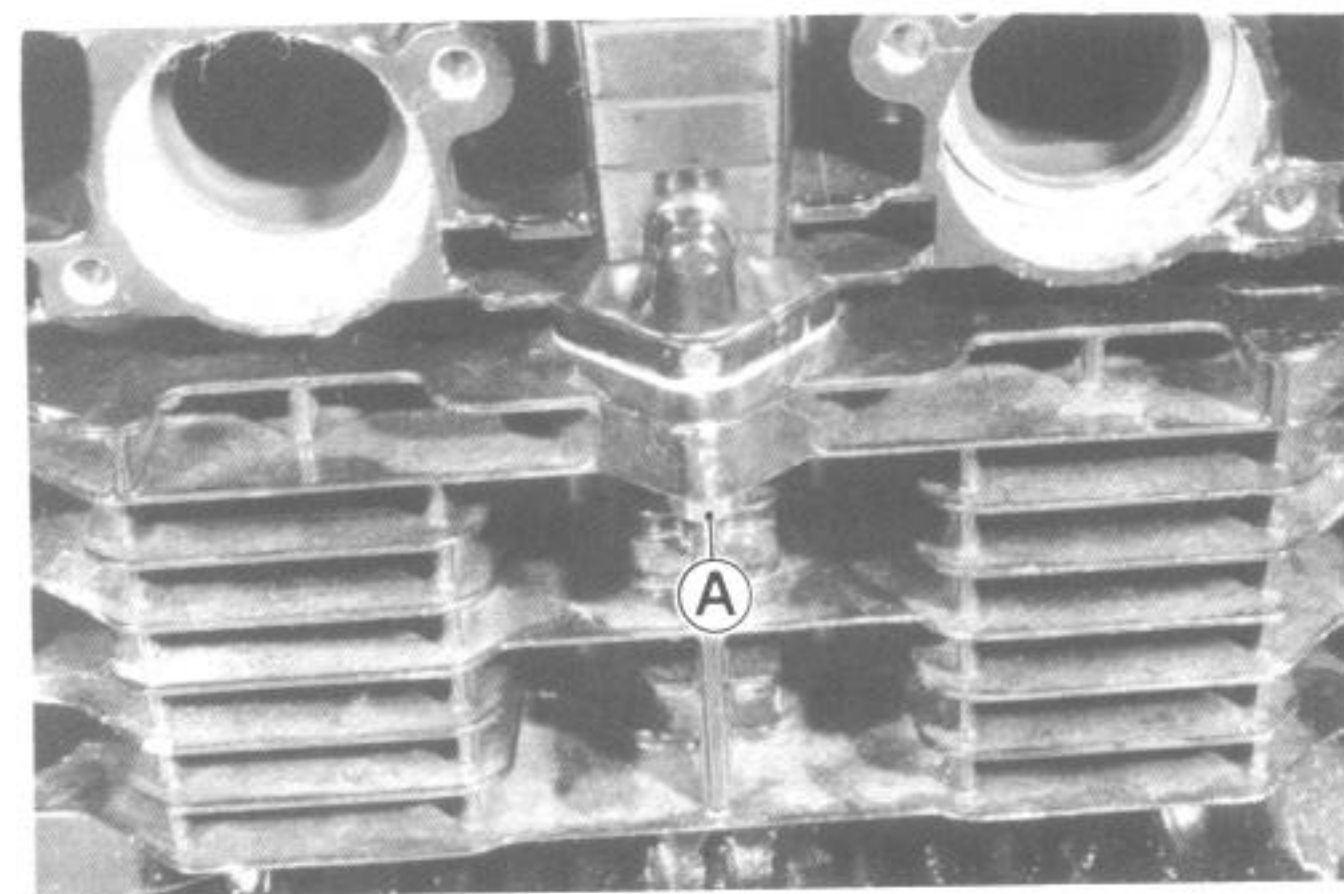
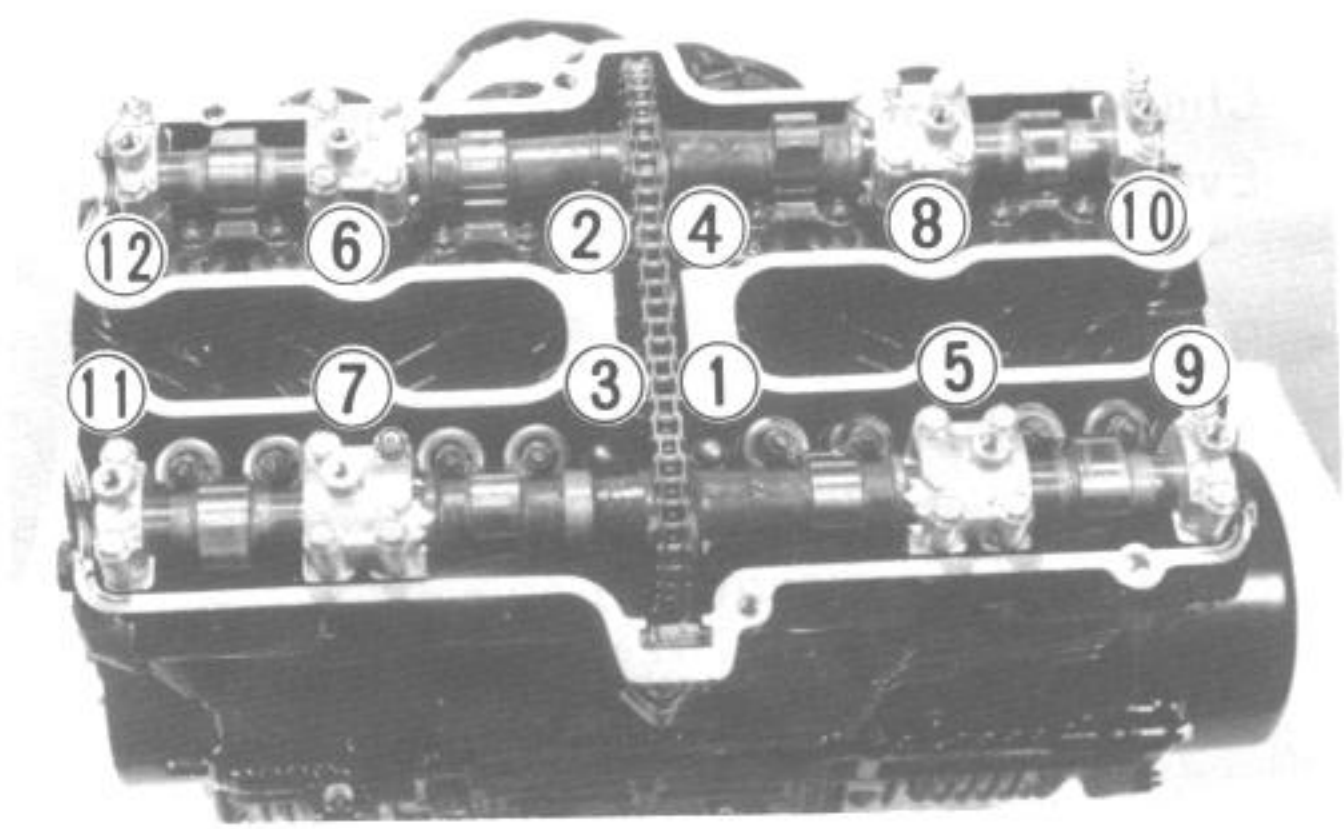

VALVE CLEARANCE

Inspect Initial 1 000 km (600 mi) and Every 5 000 km (3 000 mi).

The valve clearance specification is the same for both intake and exhaust valves.

Valve clearance adjustment must be checked and adjusted 1) at the time of periodic inspection, 2) when the valve mechanism is serviced, and 3) when the camshafts are disturbed by removing them for servicing.

Valve clearance (when cold)	0.08 – 0.13 mm
-----------------------------	----------------

NOTE:

- * The cam must be at positions, (A) or (B), in order to check the valve clearance or to adjust valve clearance. Clearance readings should not be taken with the cam in any other position than (A) or (B) positions.
 - * The clearance specification is for COLD state.
 - * To turn the crankshaft for clearance checking, be sure to use a 19-mm wrench and to rotate in normal running direction. All spark plugs should be removed.
- Turn crankshaft to bring the "T" mark on the rotor to the center of left pick up coil and also to bring the notches (1) in the both camshafts (Ex and In) of the right ends to the position as shown. In this condition, read the valve clearance at the valves (C) (In and Ex of No. 1 cylinder, Ex of No. 2 and In of No. 3).

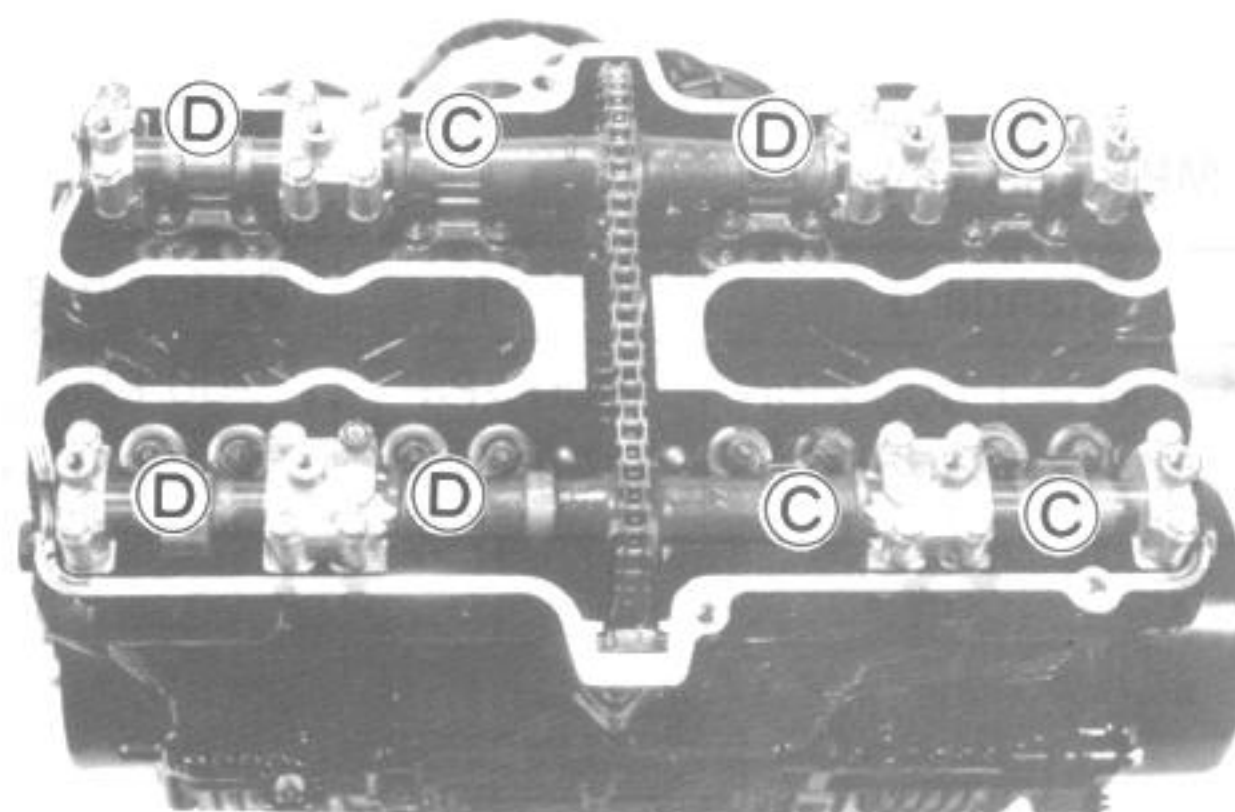
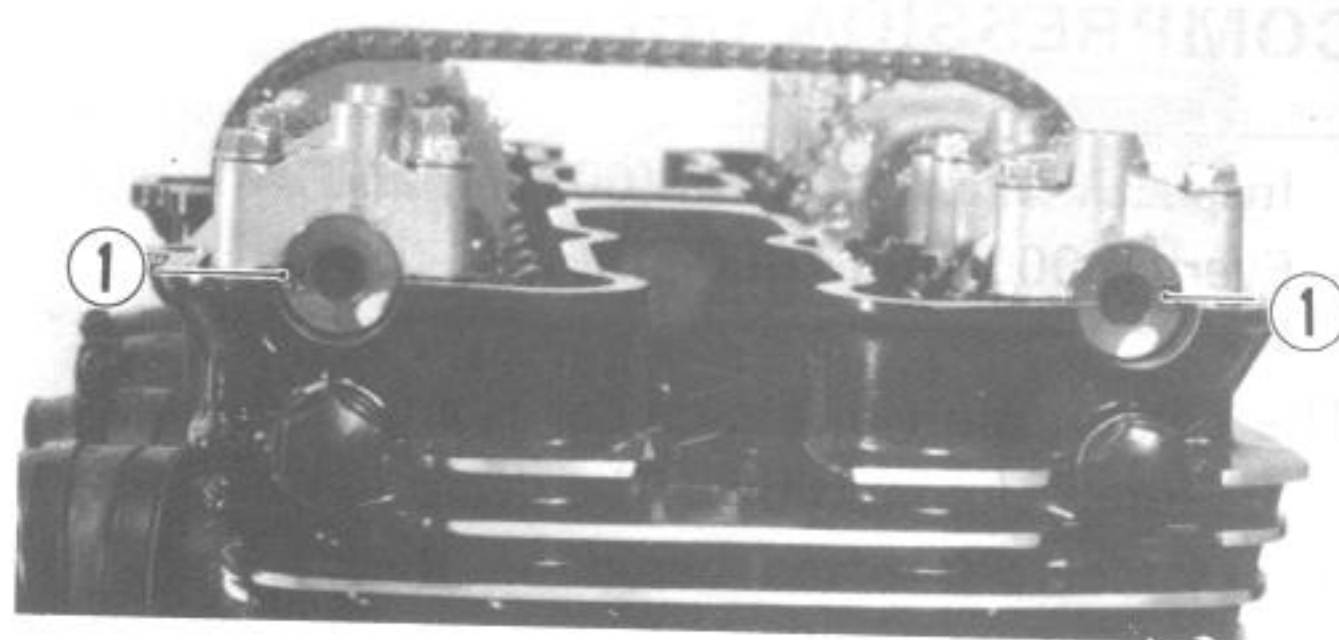
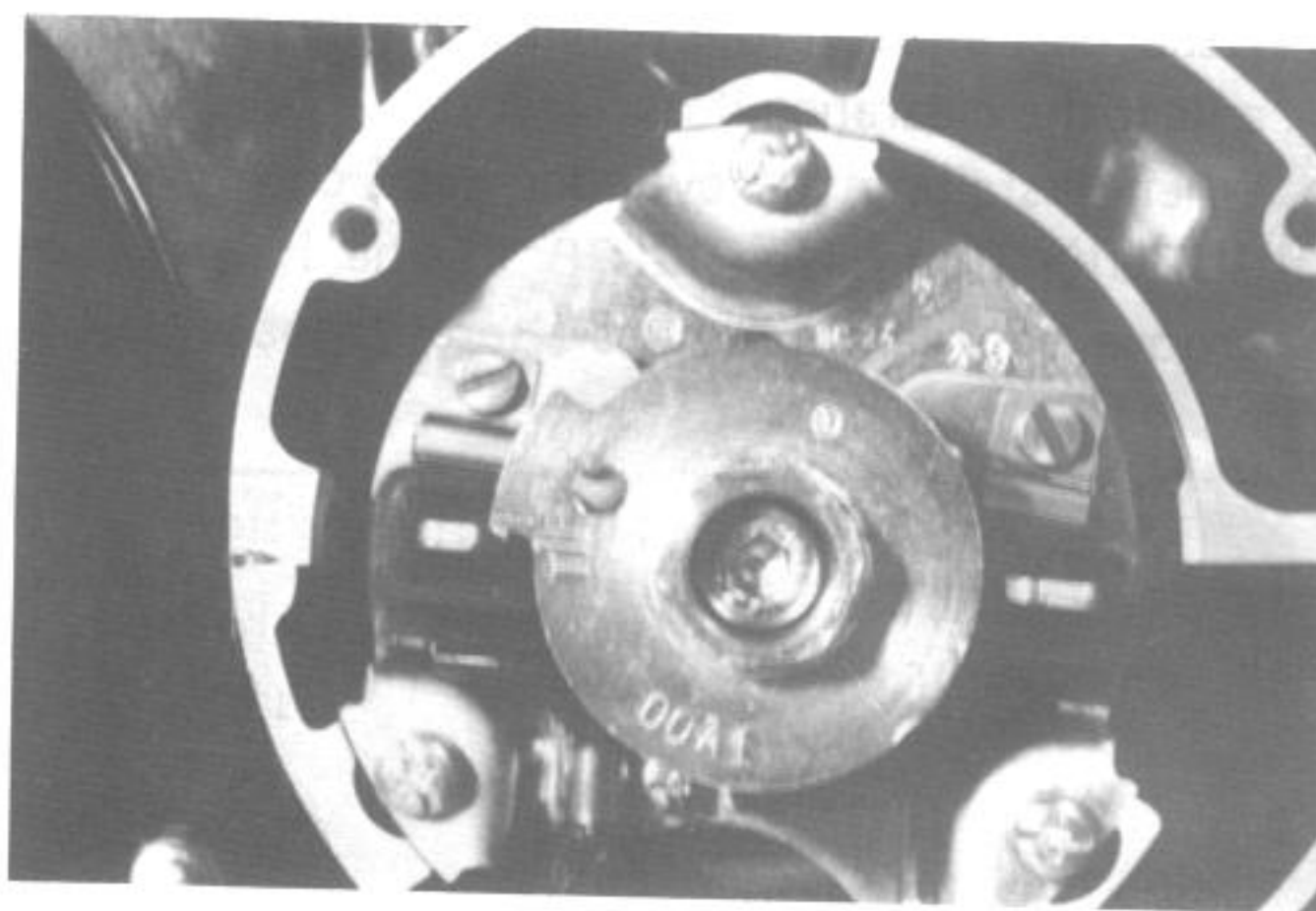
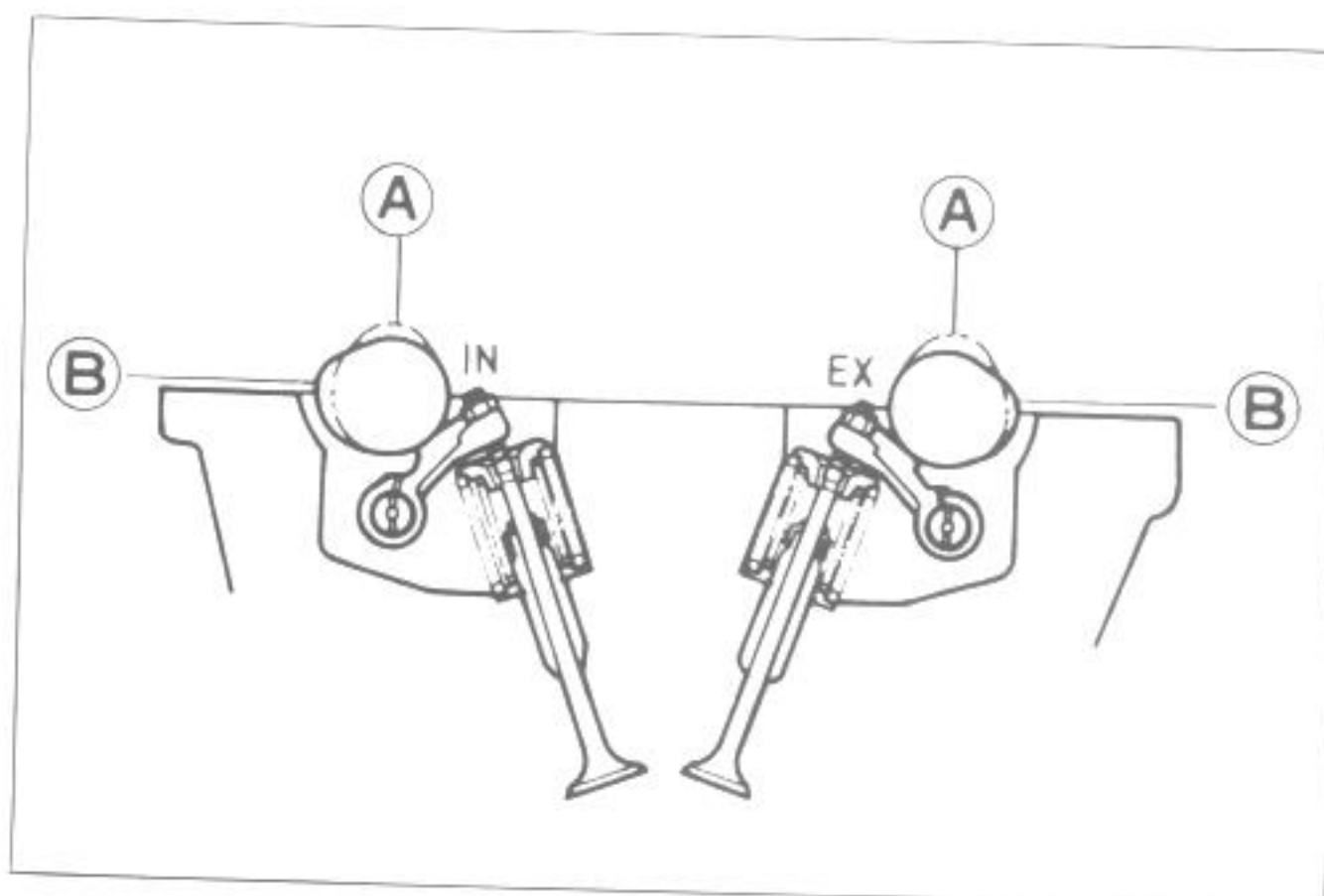

- Use thickness gauge between adjusting screw and valve stem end. If clearance is off the specification, bring it into the specified range by using the tappet adjust driver.

09900-20803	Thickness gauge
09917-14910	Tappet adjust driver

- Turn crankshaft 360° (one rotation) to bring the "T" mark on the rotor to the center of left pick up coil and also to bring the notches ① to the position shown.
- Read clearance at the remaining valves ④ and adjust the clearance if necessary.
- When installing the cylinder head cover, apply SUZUKI Bond No. 1207B to the head cover groove and cam end caps (Refer to page 3-70).

Cam Position	Notch ① position	
	Intake Camshaft	Exhaust Camshaft
③		
④		

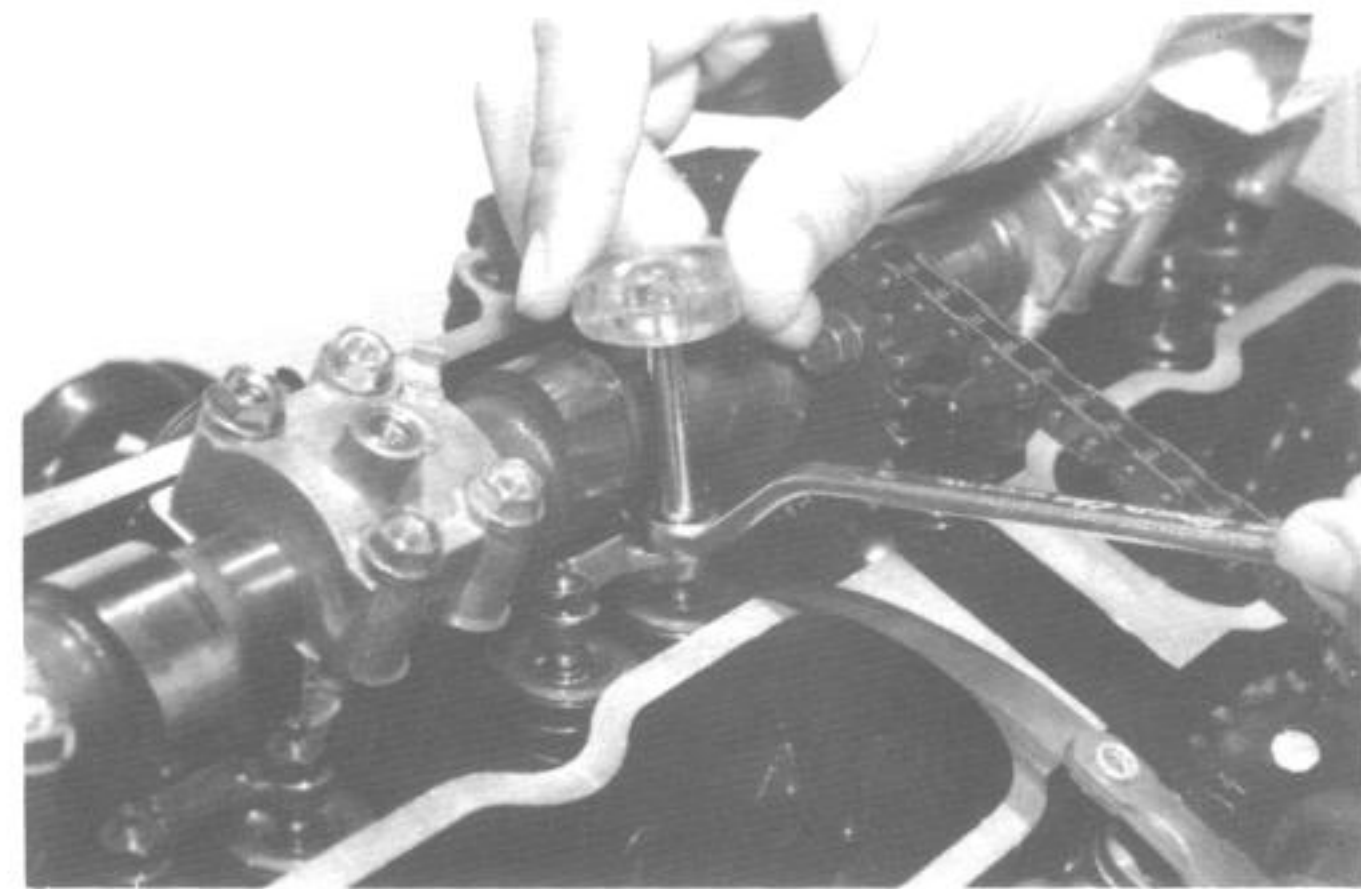
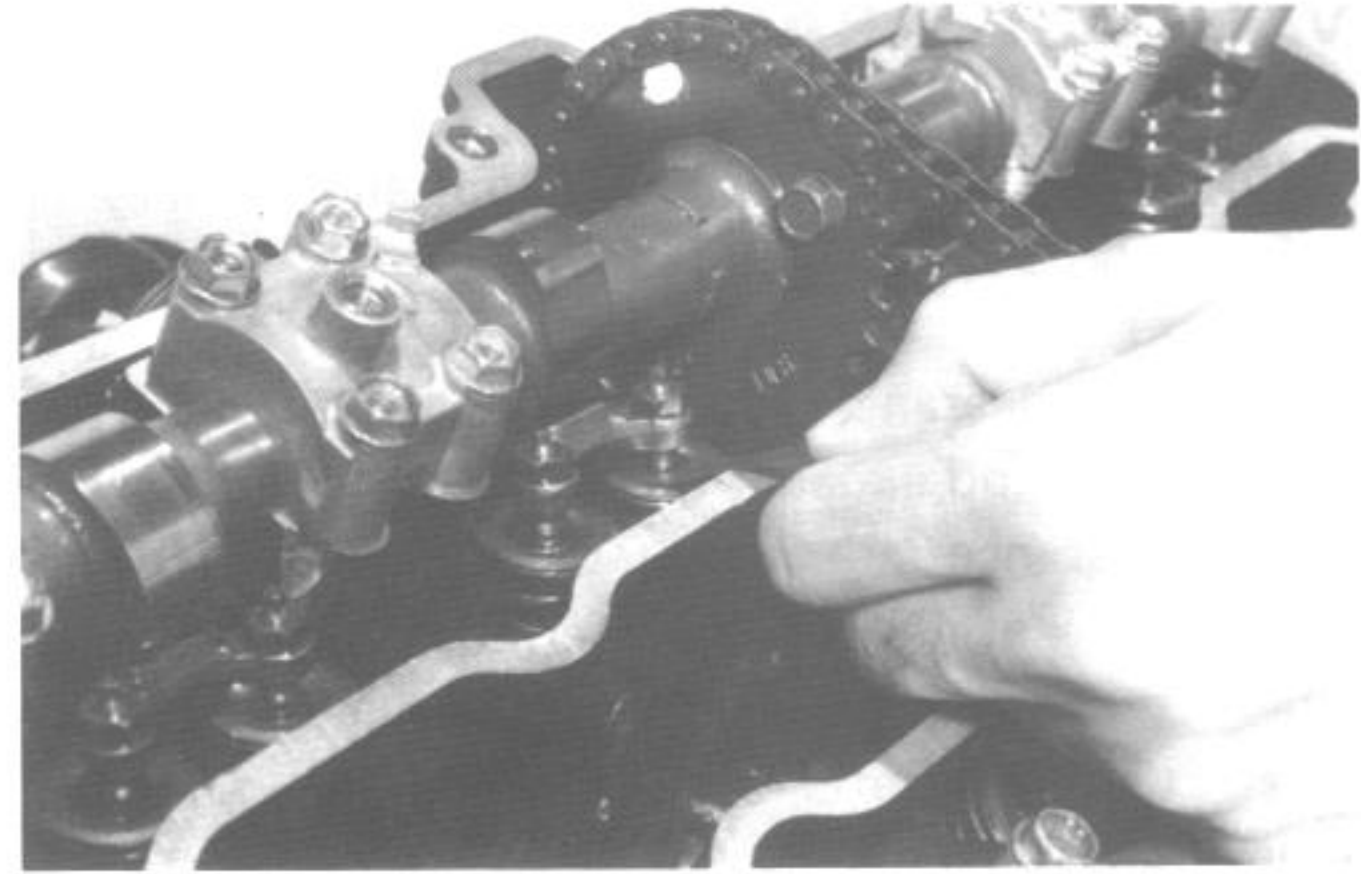

COMPRESSION CHECK

Inspect Initial 1 000 km (600 mi) and Every 5 000 km (3 000 mi).

The compression of a cylinder is a good indicator of its internal condition. The decision to overhaul the cylinders is often based on the results of a compression test. Periodic maintenance records kept at your dealership should include compression readings for each maintenance service.

COMPRESSION

Standard	Limit	Difference
1 100 – 1 500 kPa (11 – 15 kg/cm ²)	900 kPa (9 kg/cm ²)	200 kPa (2 kg/cm ²)

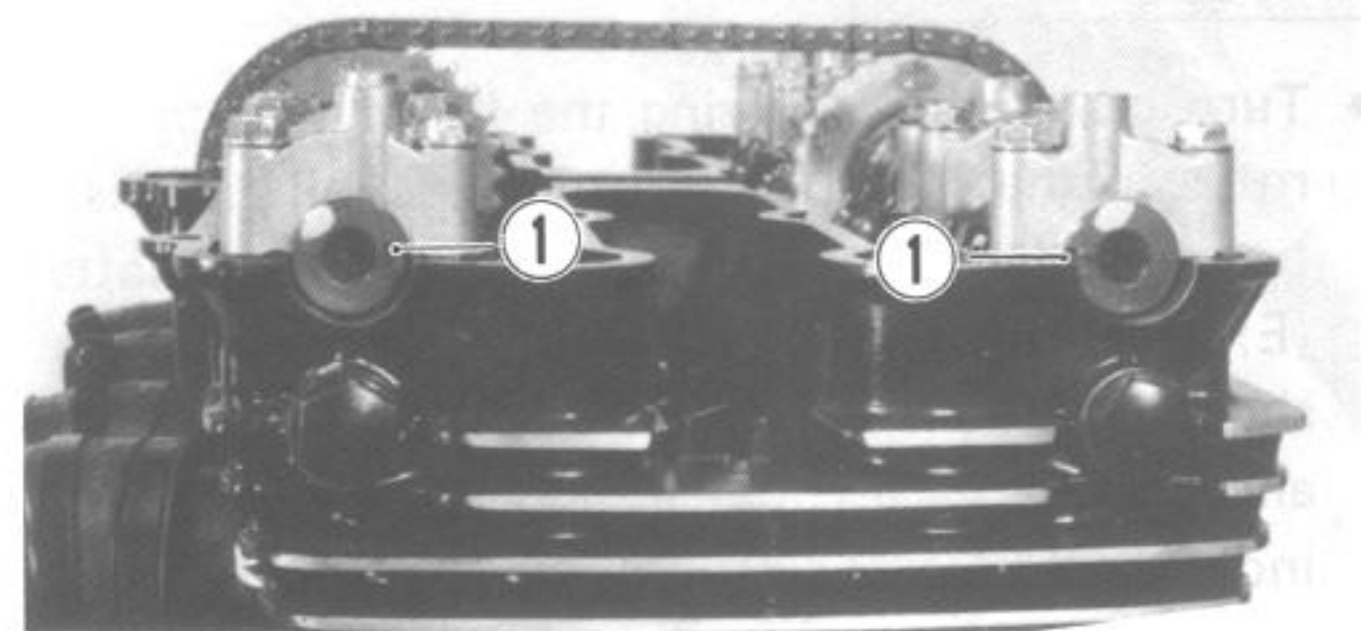

Low c
lowing
* Exce
* Worr
* Pisto
* Pool
* Rupt
gasse
Overha
* Comp
less t
* Diffe
the tv
* All c
(stand
9 kg/
Place
Remo
COMPR
NOTI
* Bef
eng
nut
tor
* War
• Remo
• Remo
0993
0993
0991
• Fit th
holes,
lutely
0991
0991
• Twist
• Crank
and re
compre
cedure

Low compression can indicate any of the following malconditions:

- * Excessively worn cylinder wall
- * Worn-down piston or piston rings
- * Piston rings stuck in the grooves
- * Poor sealing of valves
- * Ruptured or otherwise defective cylinder head gasket

Overhaul the engine in the following cases:

- * Compression pressure in any one of cylinder is less than 9 kg/cm²
- * Difference in compression pressure between the two is more than 2 kg/cm²
- * All compression pressures are below 11 kg/cm² (standard) even when they measure more than 9 kg/cm²

COMPRESSION TEST PROCEDURE

NOTE:

- * Before testing the compression of the engine, make sure that the cylinder head nuts and bolt are tightened to the specified torque values.
- * Warm up the engine before testing.

- Remove the seat and fuel tank.
- Remove all spark plugs.

09930-13210	Socket wrench
09930-14530	Universal joint
09914-24510	T handle

- Fit the compression gauge to one of the plug holes, taking care that the connection is absolutely tight.

09915-64510	Compression gauge
09915-63210	Compression adapter

- Twist the throttle grip into full-open position.
- Crank the engine a few seconds with the starter and read the maximum gauge reading as the compression of that cylinder. Repeat this procedure with the other cylinders.

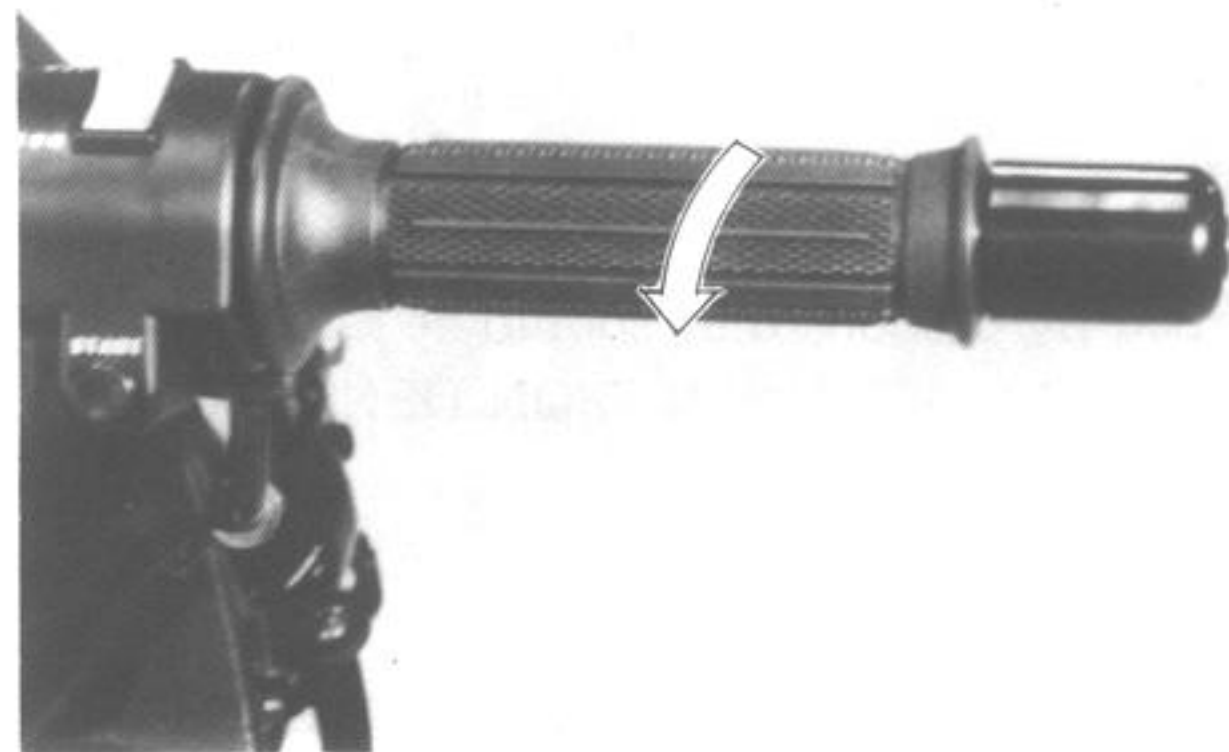
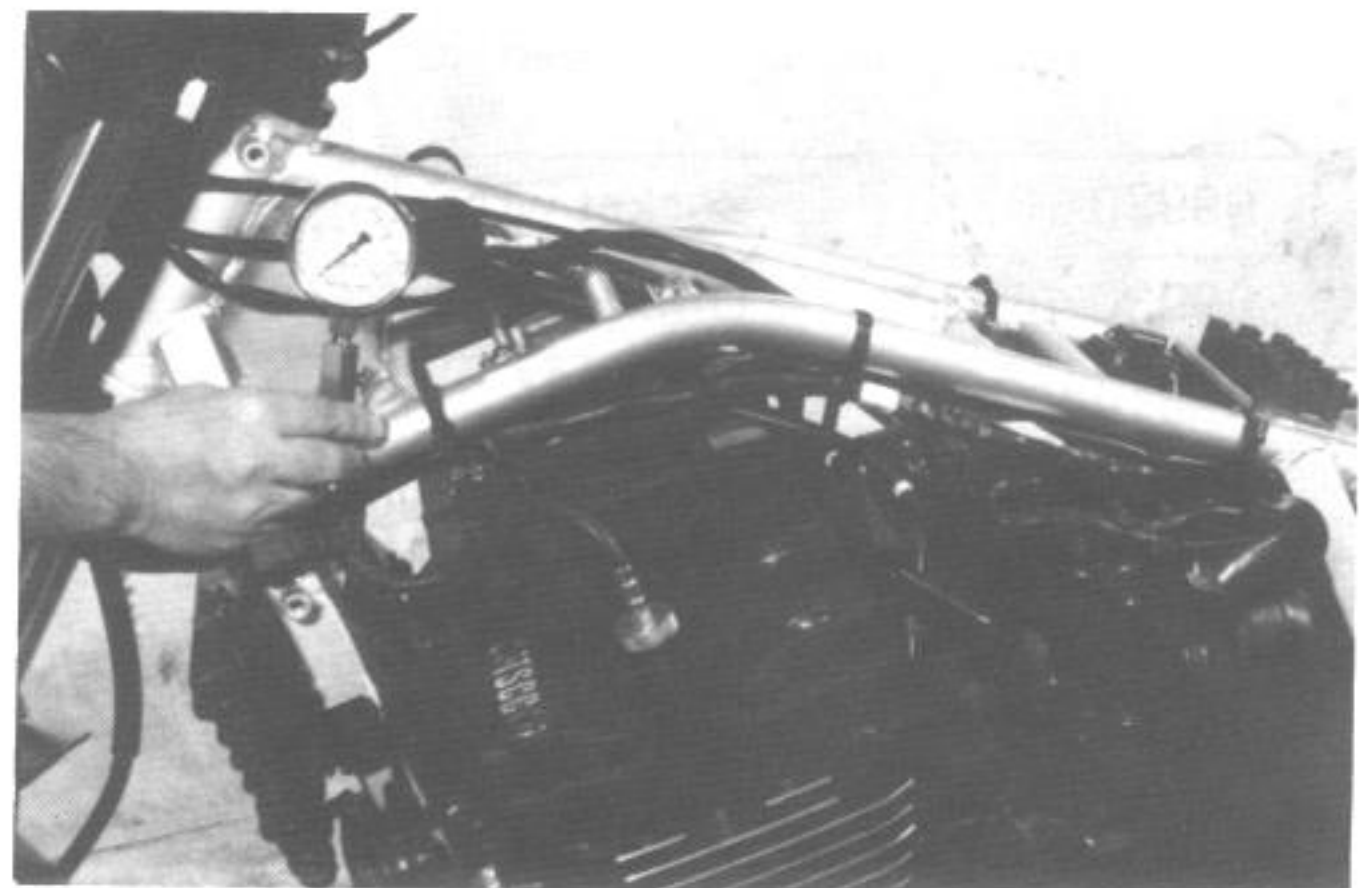

SPARK PLUG

Clean and Adjust Initial 1 000 km (600 mi)
and Every 5 000 km (3 000 mi),
Replace Every 10 000 km (6 000 mi)

The plug gap is adjusted to 0.6–0.7 mm. The gap is correctly adjusted using a thickness gauge. When carbon is deposited on the spark plug, remove the carbon with a spark plug cleaning machine or by carefully using tool with a pointed end. If electrodes are extremely worn or burnt, replace the plug. Also replace the plug if it has a broken insulator, damaged thread, etc.

09930-13210	Socket wrench
09930-14530	Universal joint
09914-24510	T handle
09900-20803	Thickness gauge

NGK D9EA or NIPPON DENSO X27ES-U listed in the table should be used as the standard plug. However, the heat range of the plug should be selected to meet the requirements of speed, actual load, fuel, etc. If the plugs need to be replaced, it is recommended that to the standard plugs listed in the table be selected.

Remove the plugs and inspect the insulators. Proper heat range would be indicated if all insulators were light brown in color. If they are blackened by carbon, they should be replaced by a hot type NGK D8EA or NIPPON DENSO X24ES-U.

NOTE:

“R” type spark plug fitted under some of specifications and it means that the resistor is located at the center electrode to prevent radio noise.

NOTE:

To check the spark plugs, first make sure the fuel tank contains unleaded gasoline and if all the plugs are either sooty with carbon or burnt white, replace them altogether.

CAUTION:

Confirm the thread size and reach when replacing the plug. If the reach is too short, carbon will be deposited on the screw portion of the plug hole and engine damage may result.

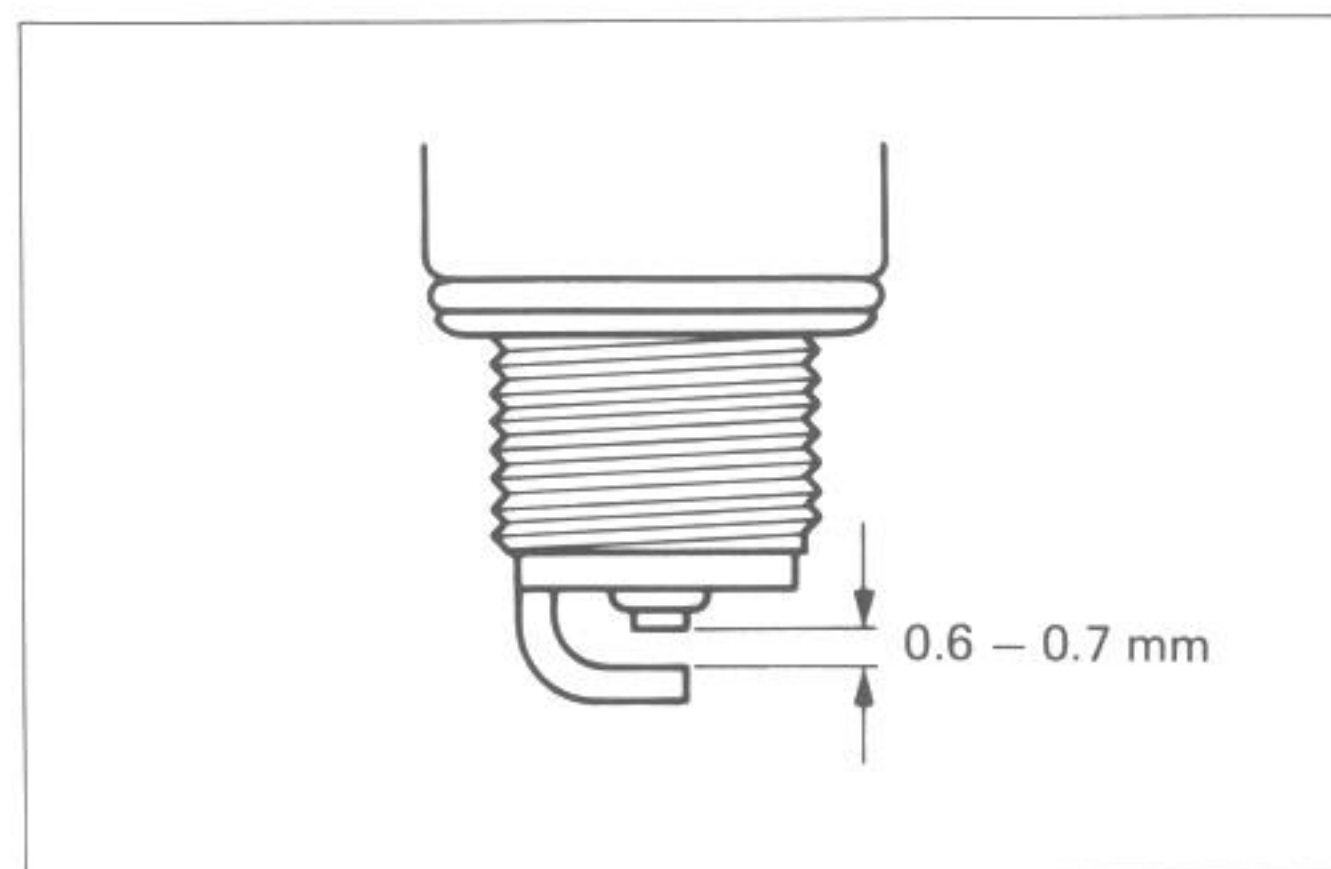
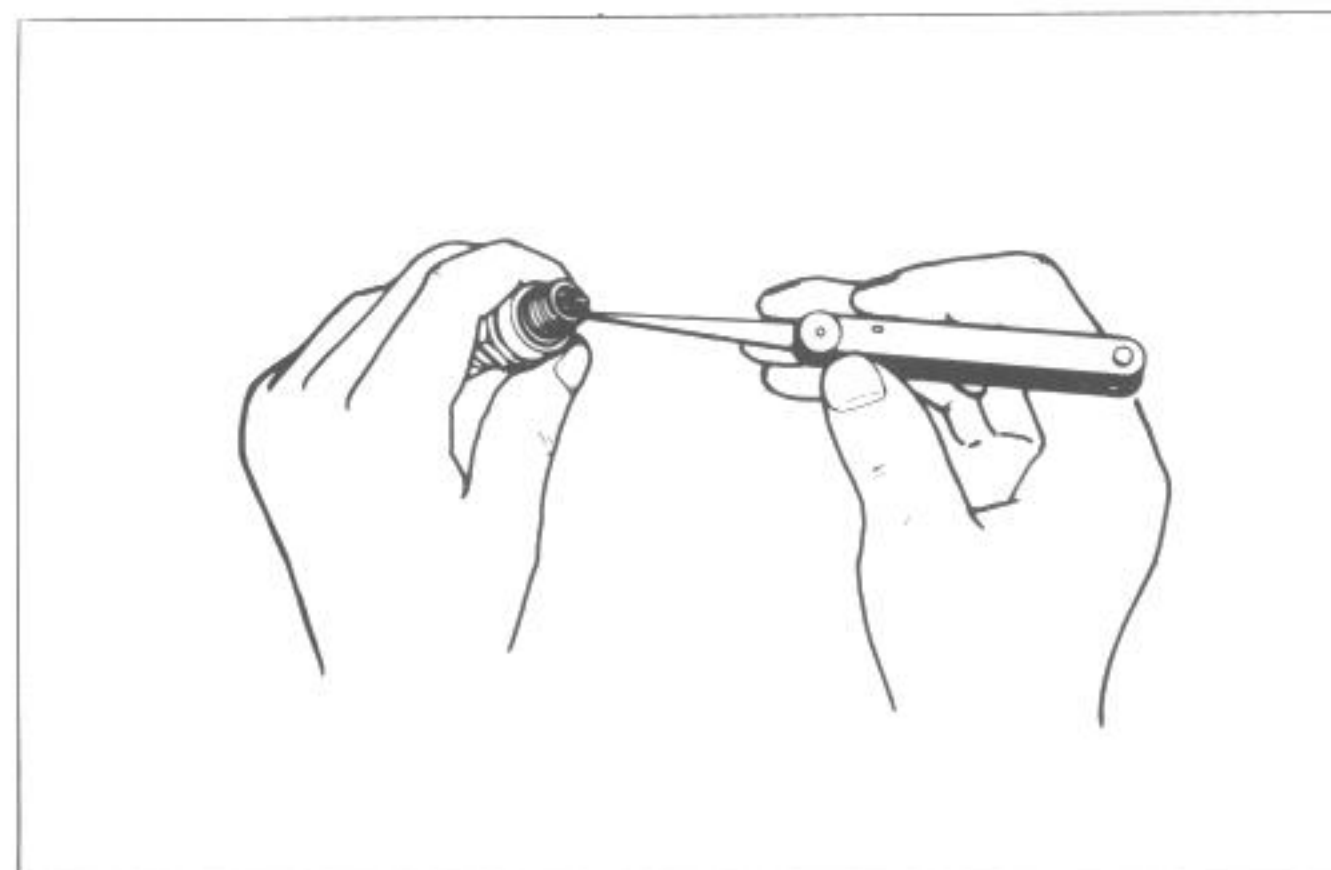

NGK	NIPPON DENSO	REMARKS
D8EA (DR8ES-L)	X24ES-U (X24ESR-U)	If the standard plug is apt to get wet, replace with this plug. Hot type.
D9EA (DR8ES)	X27ES-U (X27ESR-U)	Standard

CAR
Ins
Ever
THRO
There
cable.
• Push
of p
• Loo
②
obta
FUEL
• Plac
• Rem
fuel
09
sho
• Run
1 15
midd
lowe
phot
Dis
• Repe
NOT
When
“O”
• If fue
4-11 t

CARBURETOR

Inspect Initial 1 000 km (600 mi) and
Every 5 000 km (3 000 mi)

THROTTLE CABLE PLAY

There should be 2 – 3 mm play (A) on the throttle cable. To adjust the throttle cable play:

- Push the throttle cable to check the amount of play.
- Loosen the lock nuts (1) and slide the adjuster (2) upper or lower until the specified play is obtained.

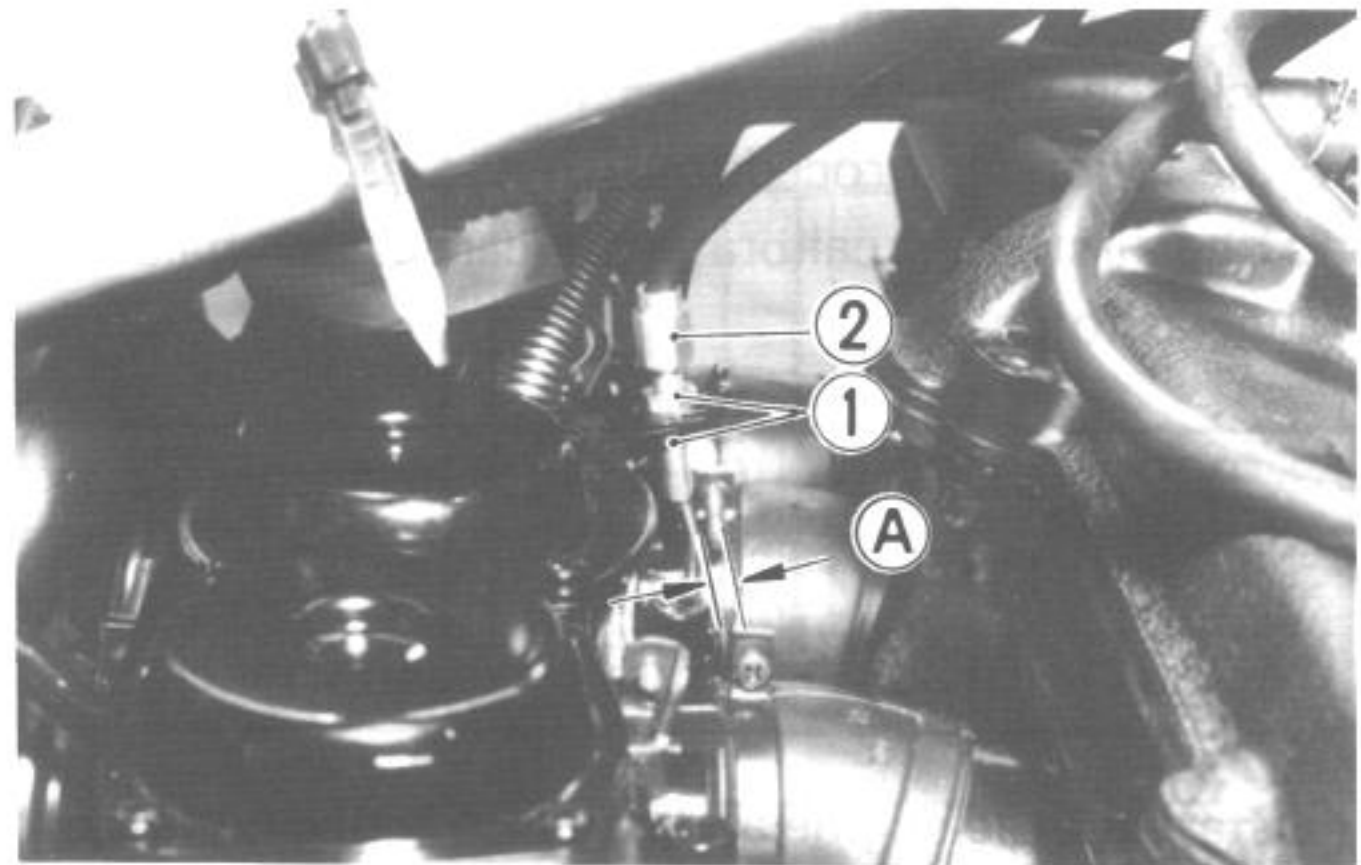

FUEL LEVEL INSPECTION

- Place machine on center stand.
- Remove carburetor drain plug and install the fuel level gauge.

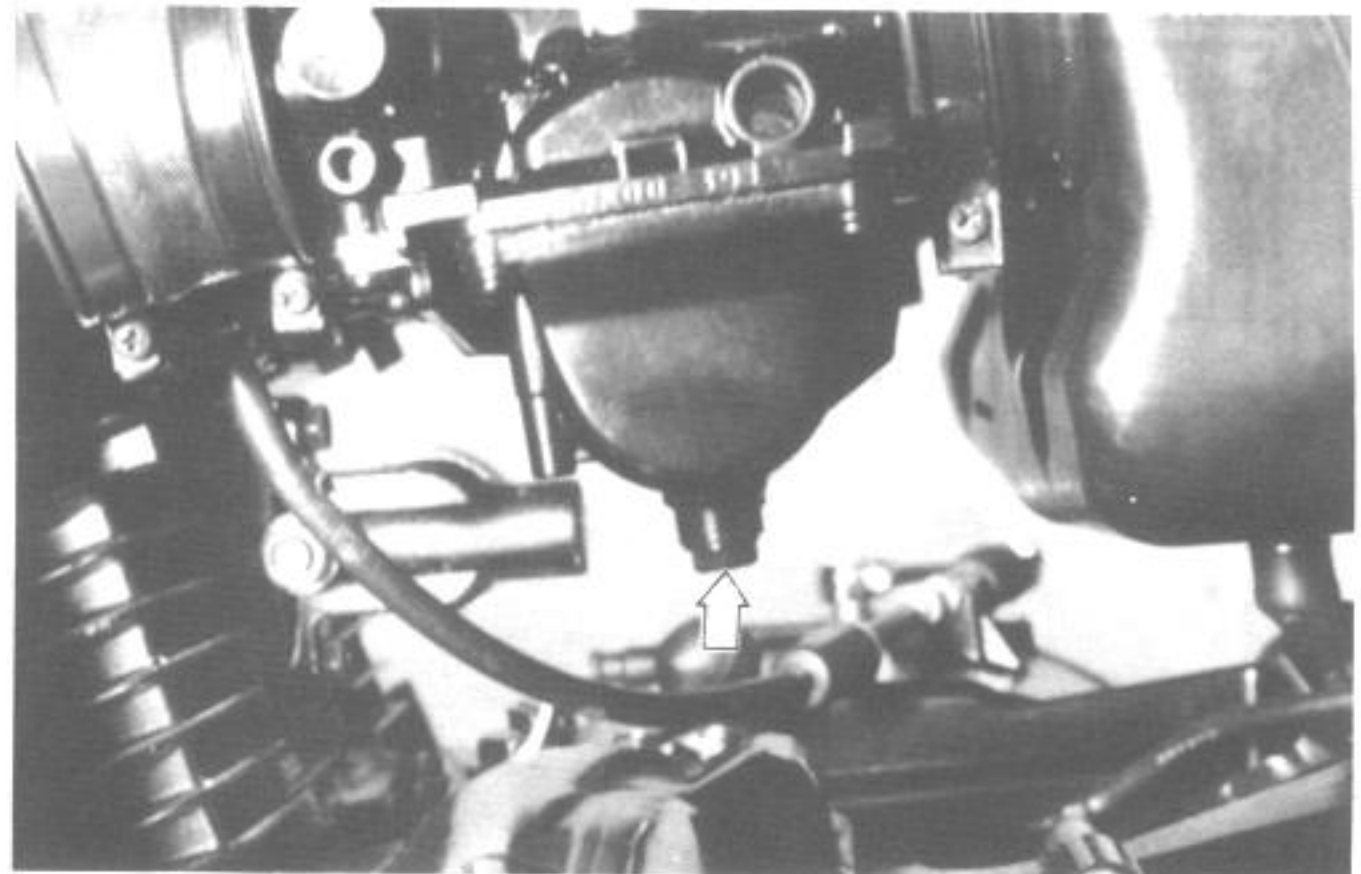

09913-14511

Fuel level gauge

- Run the engine at the idling speed (1 050–1 150 r/min), and measure the distance with the middle line of the level gauge aligned with the lower surface of carburetor body as shown in photo. (B) should be within the specified range.

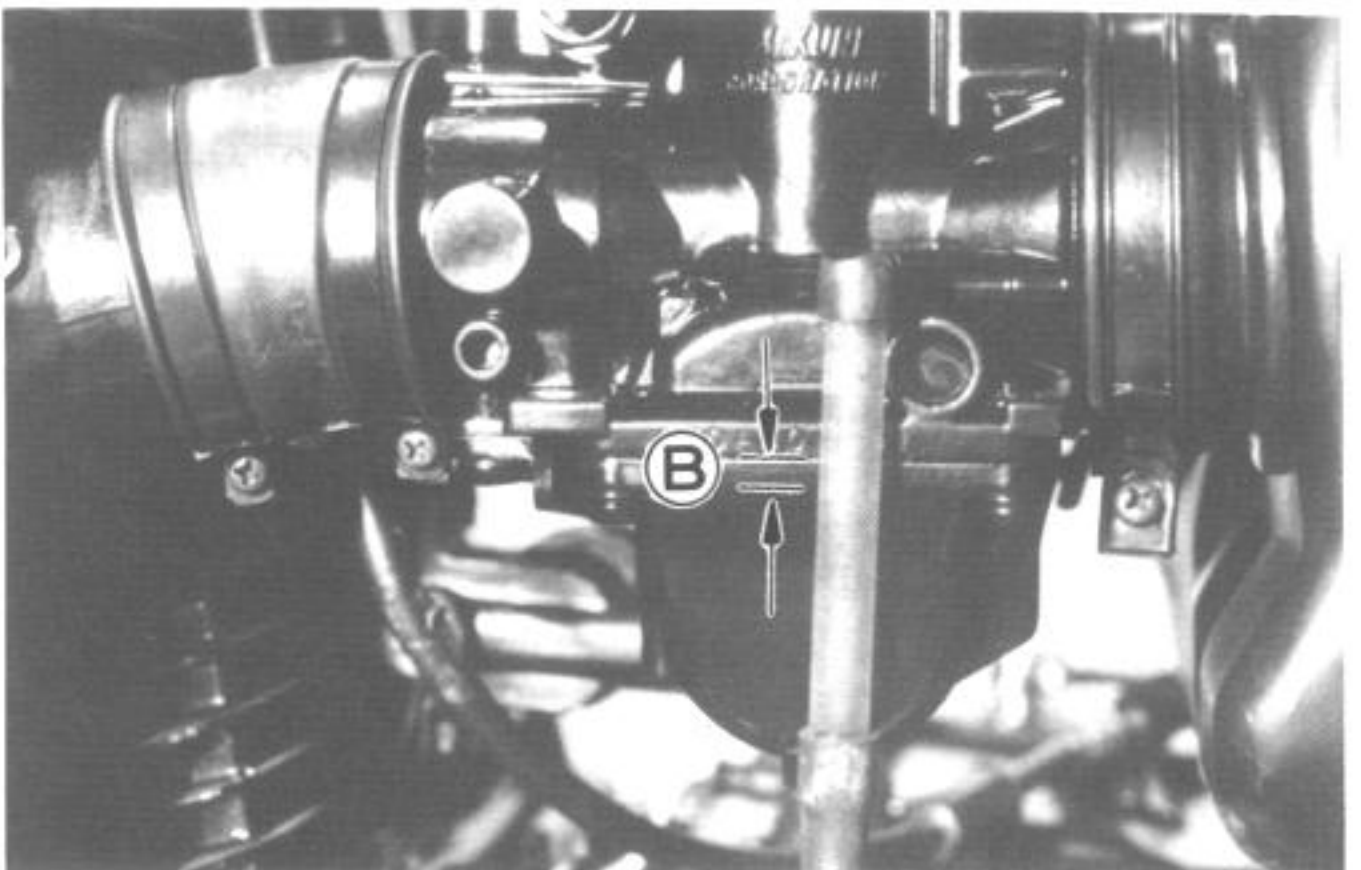

Distance (B)

3.0 ± 0.5 mm

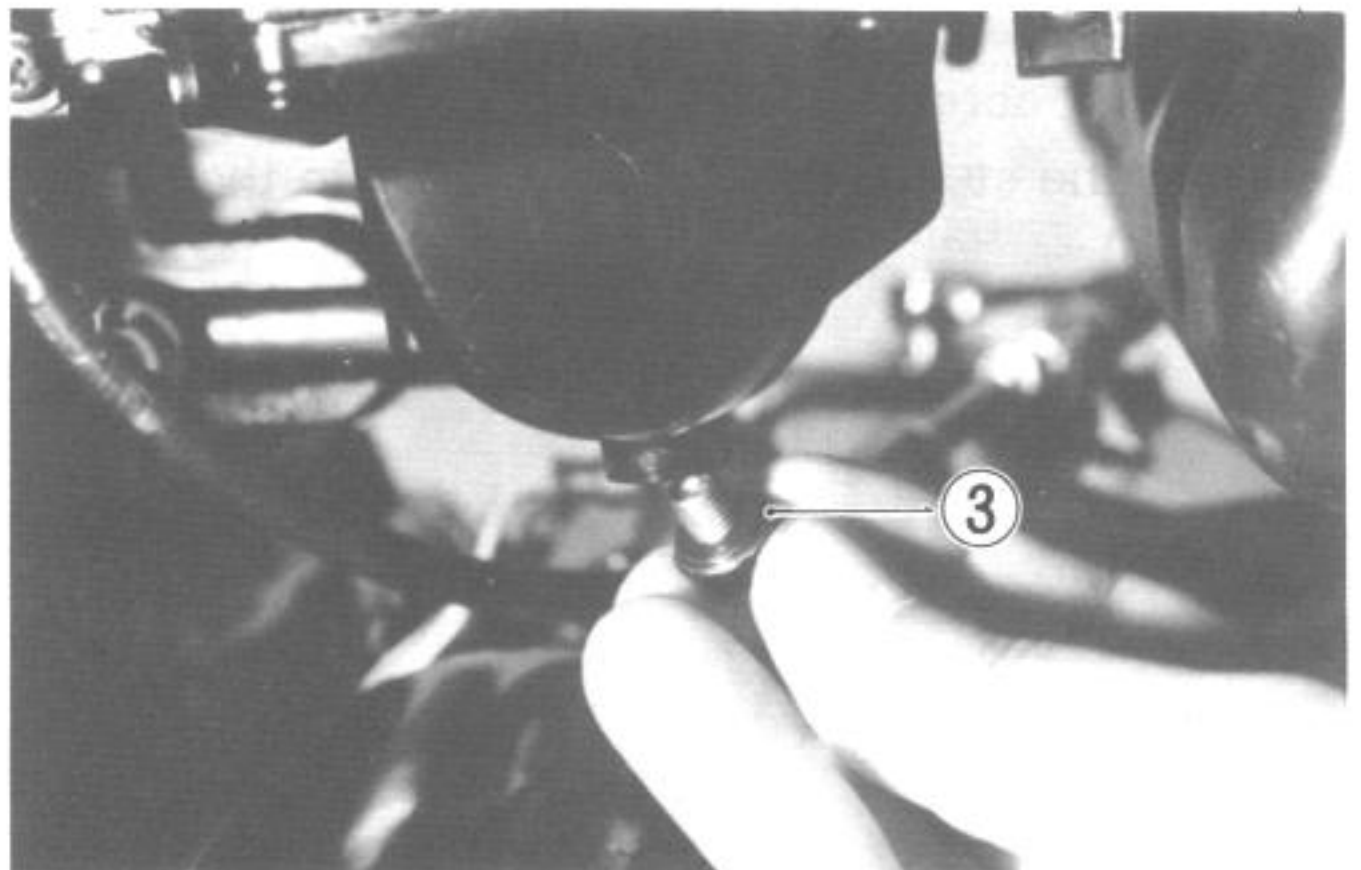

NOTE:

When refitting the screw, be sure to use the "O" ring (3).

- If fuel level readjustment is necessary, see page 4-11 for adjusting float height.

BALANCING CARBURETORS

Check the four carburetors for balance according to the following procedures.

As the first step, calibrate the carburetor balancer gauge as follows:

09913-13121	Carburetor balancer
09913-13140	Adapter
09911-70130	4 mm Hexagon wrench

- Start up the engine and run it in idling condition for warming up.
- Stop the warmed-up engine. By using the 4-mm hexagon wrench ①, remove vacuum inlet screw for No. 1 or No. 4 cylinder and install adapter ② with O-ring.

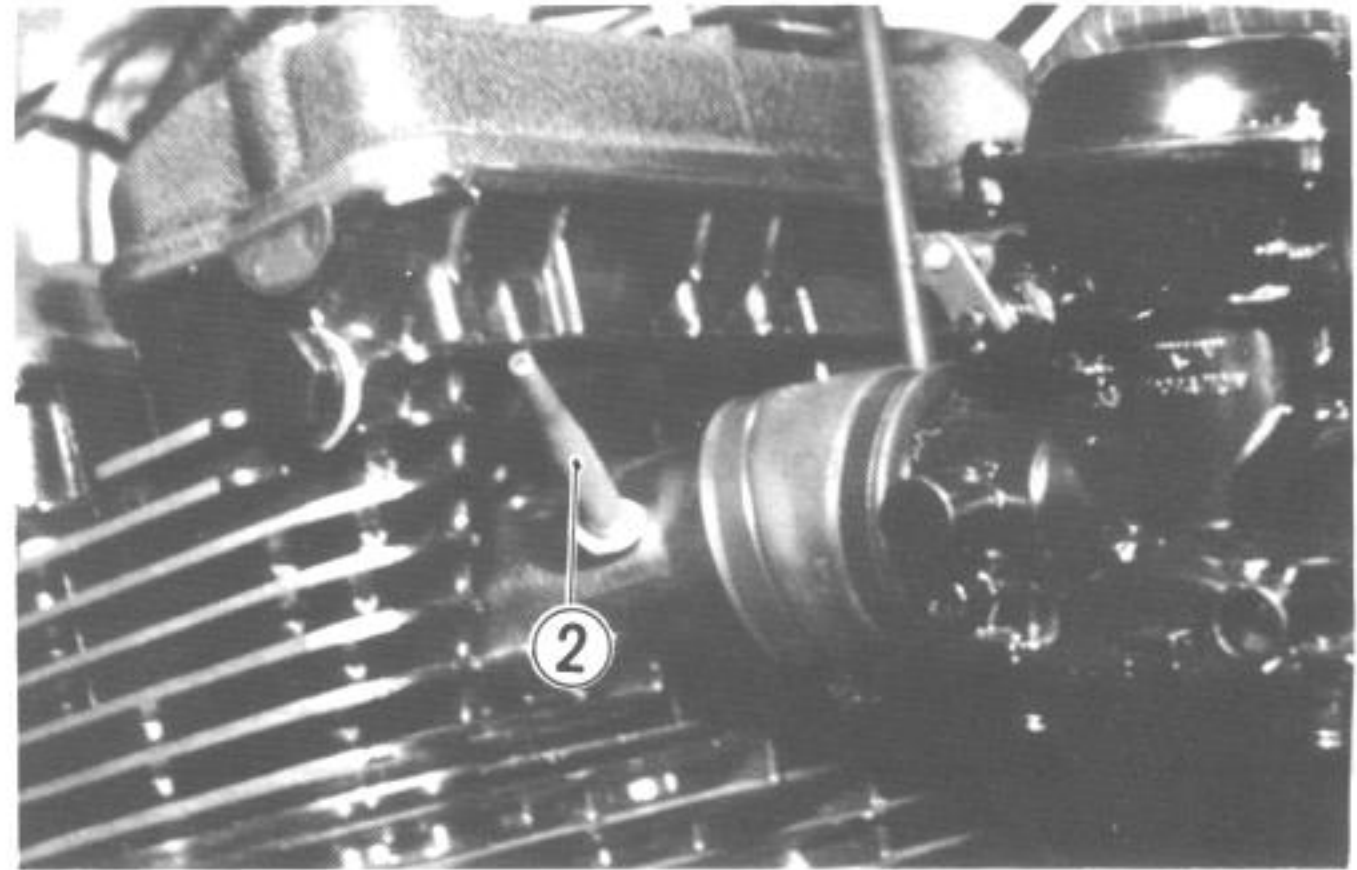
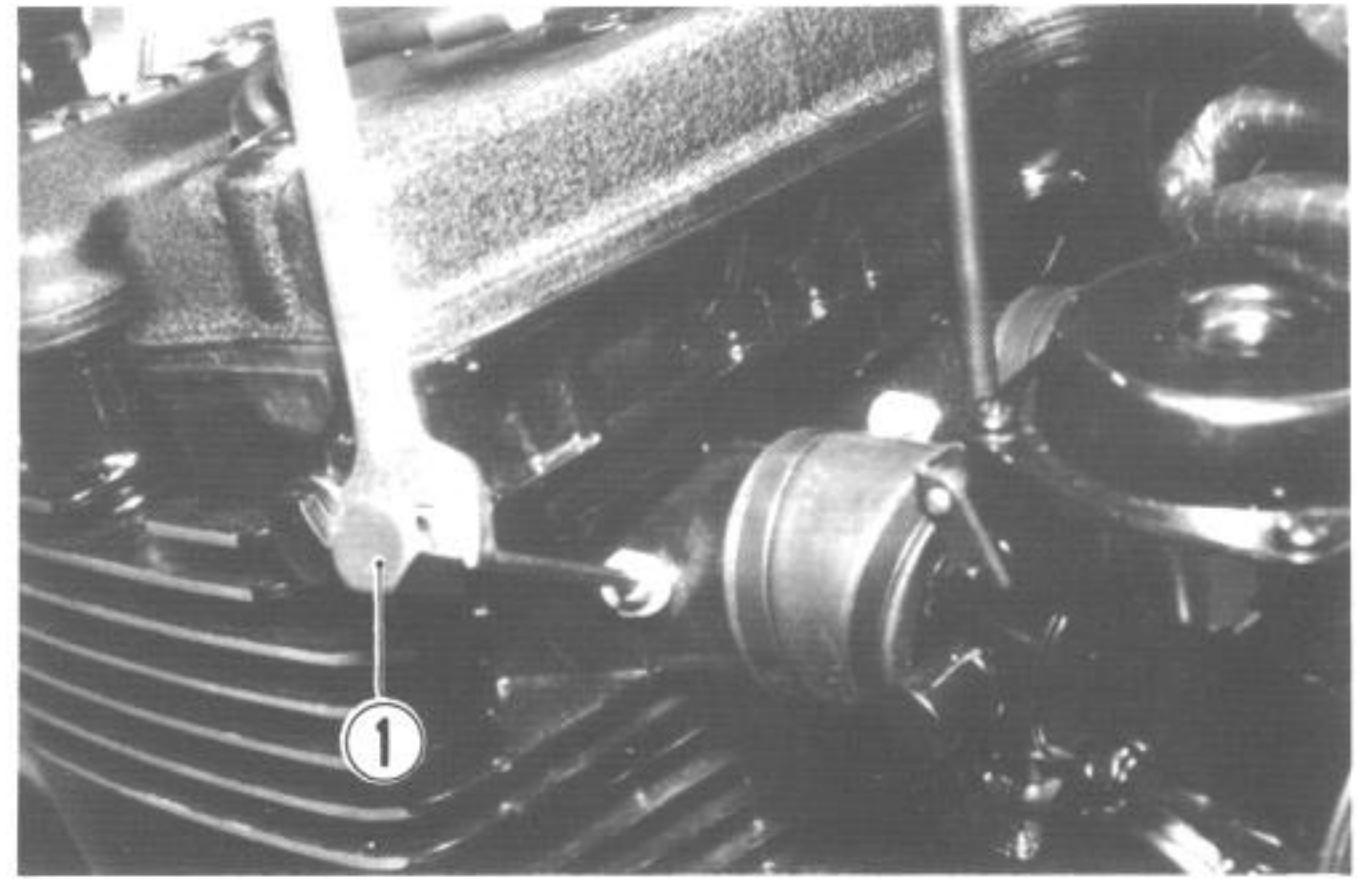

- Connect one of the four rubber hoses of the balancer gauge to this adapter, and start up the engine, and keep it running at 1 750 r/min by turning throttle stop screw ③.

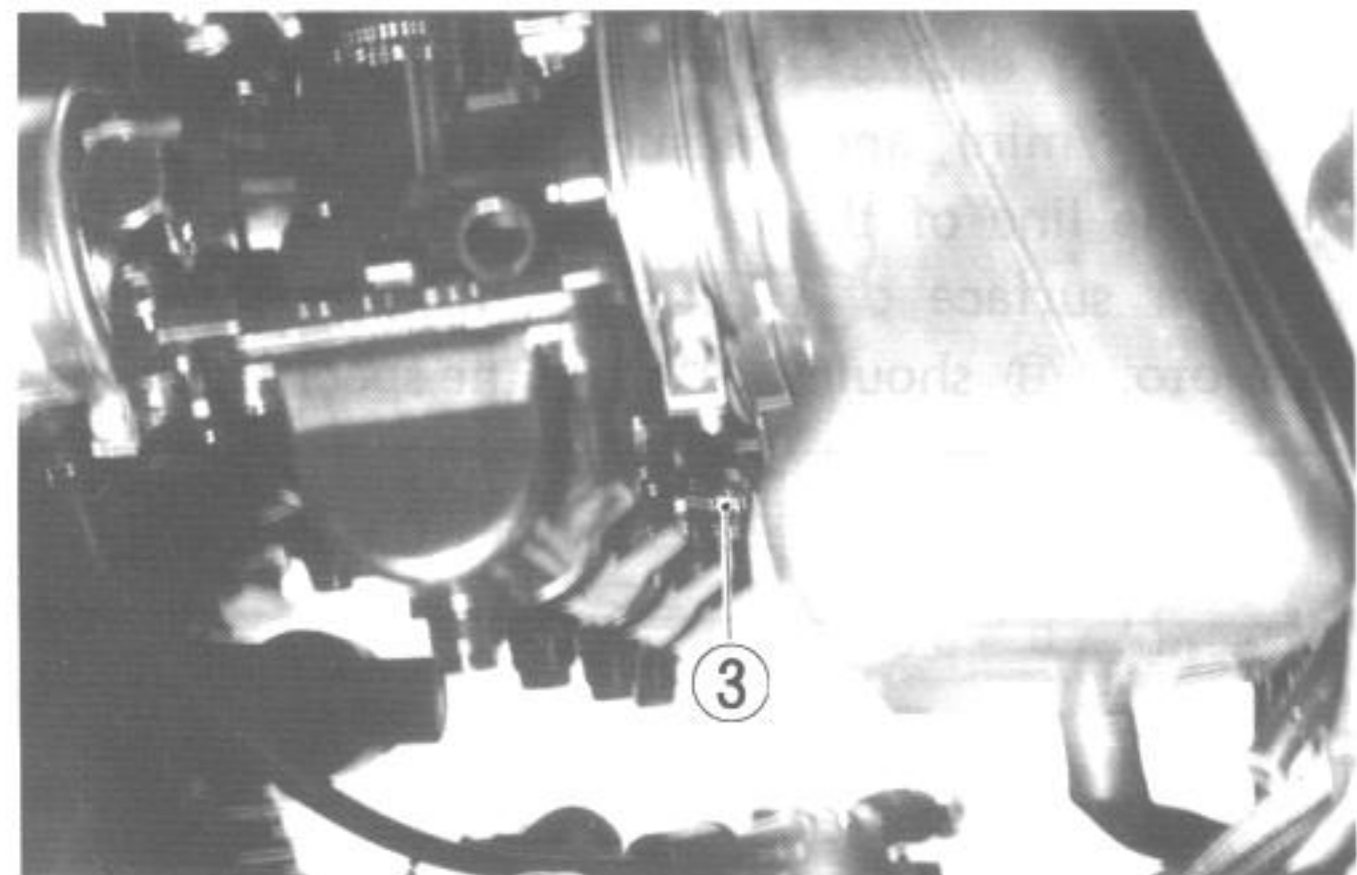

- Turn the air screw ④ of the gauge so that the vacuum acting on the tube of that hose will bring the steel ball ⑤ in the tube to the center line ⑥.

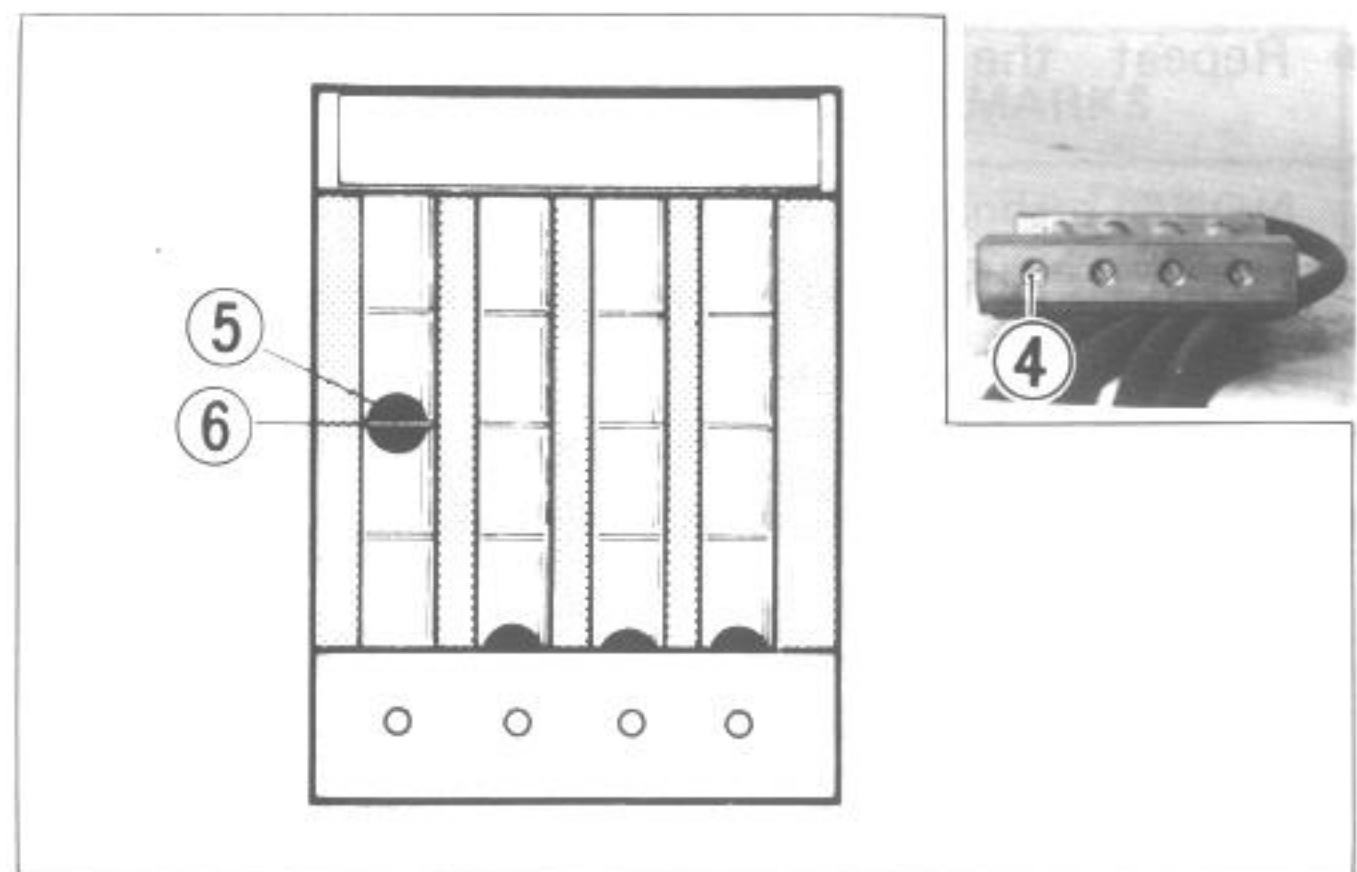

• Af
ste
fro
the
ste
• Re
tub
in b

Remo
insert
balanc
the fo

• Star
1 75
• A c
ball
leve
at t
ball
show

• If th
just
by u

099

Adjusti

Ⓐ ()
→ ()

NOTI
* If
ges
fue
tan
* Be
* Eac
car

Oil c
Filter
Over

- After making sure that the steel ball stays steady at the center line, disconnect the hose from the adapter and connect the next hose to the adapter. Turn air screw to bring the other steel ball ① to the center line.
- Repeat the process on the third and fourth tubes. The balancer gauge is now ready for use in balancing the carburetors.

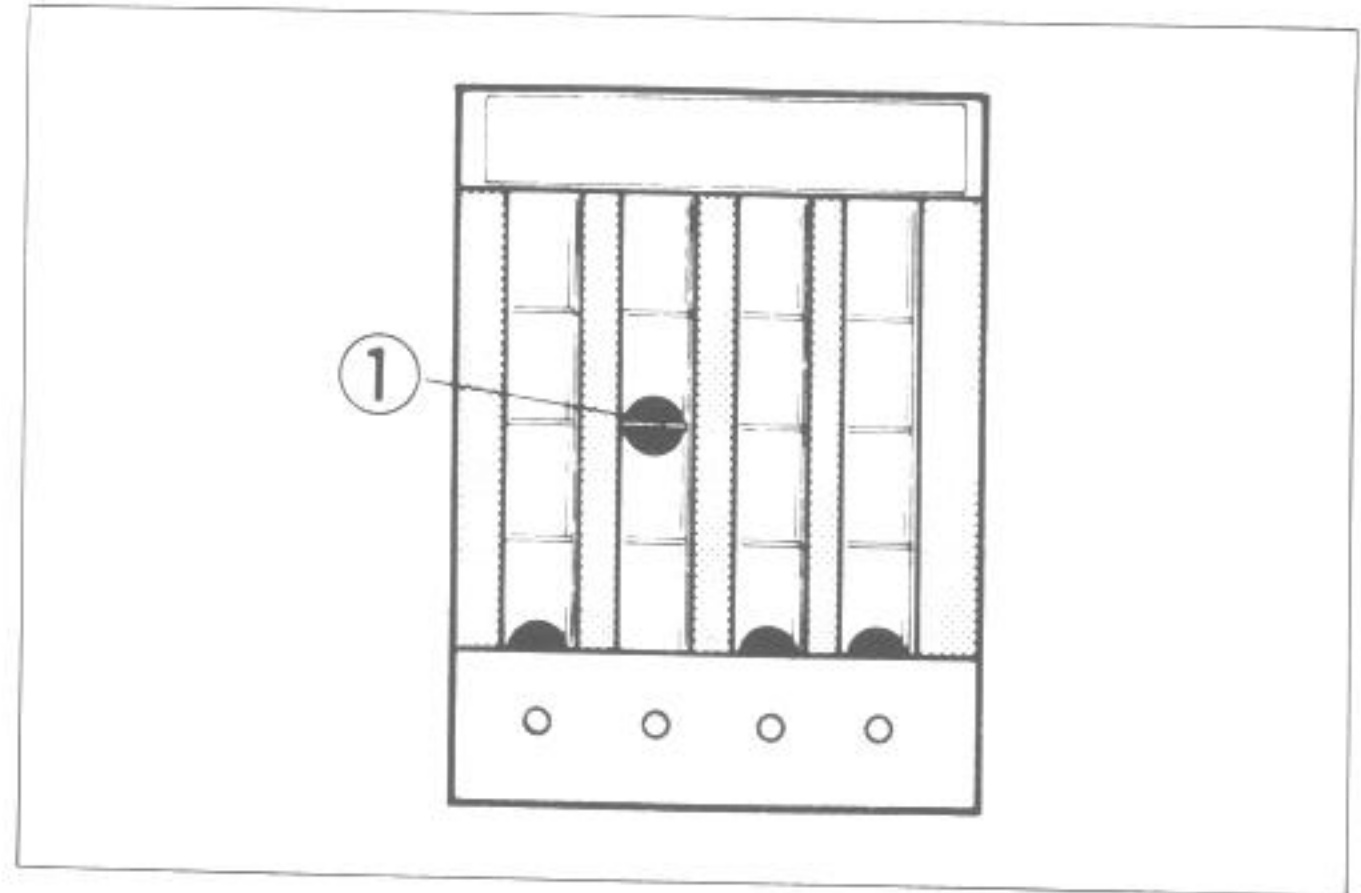

Remove the respective vacuum inlet screws and insert the adapters in the holes. Connect the balancer gauge hoses to these adapters, and balance the four carburetors as follows:

- Start up the engine, and keep it running at 1 750 r/min.
- A correctly adjusted carburetor has the steel balls in the Nos. 1 and 4 tubes at the same level, and those in the Nos. 2 and 3 tubes also at the same level, but lower by one half of the ball diameter than the Nos. 1 and 4 tubes as shown.
- If the steel balls are not in correct positions, adjust the throttle valve adjusting screw correctly by using throttle valve adjust wrench.

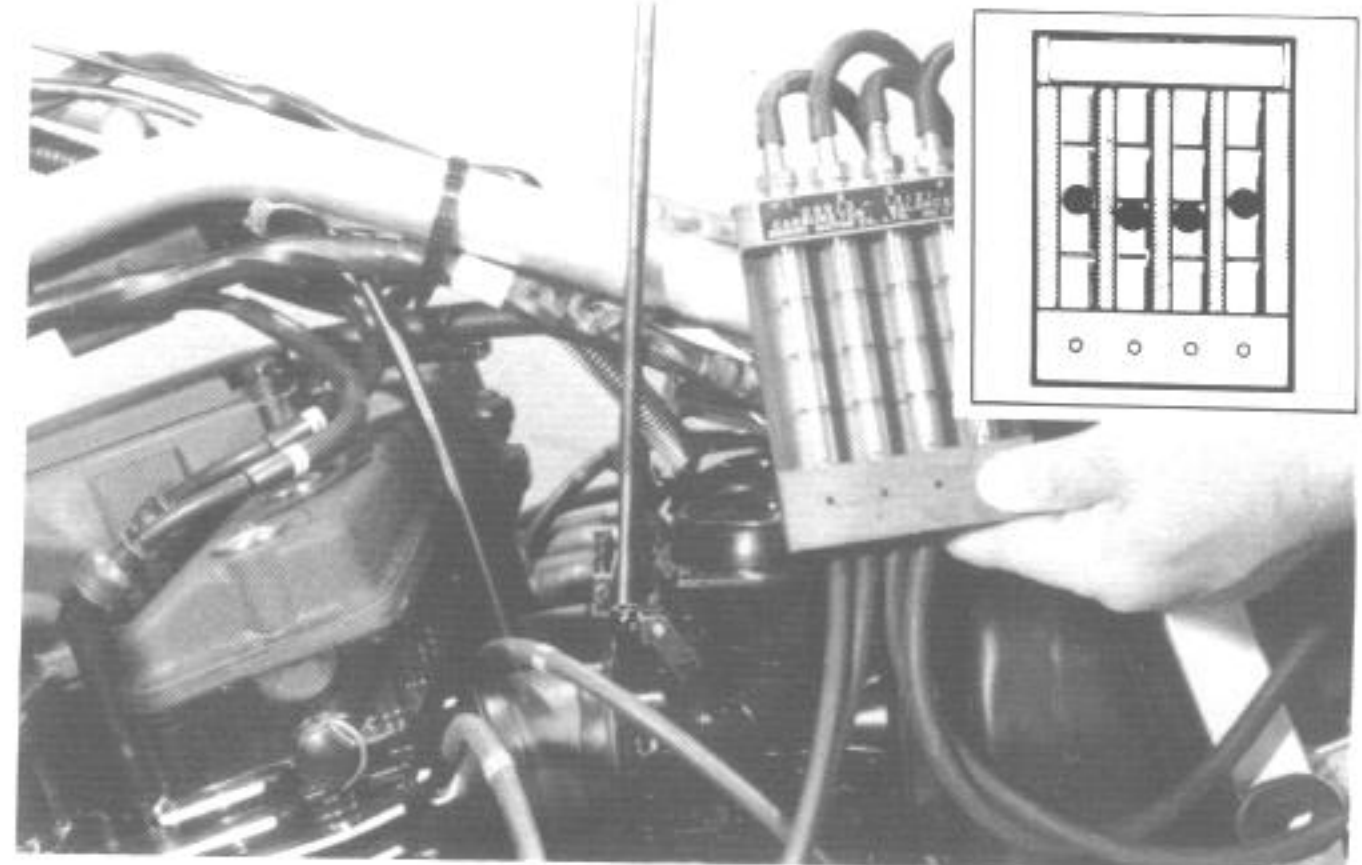

09913-14911	Throttle valve adjust wrench
-------------	------------------------------

Adjusting order:

(A) (for No. 2 Carb) → (B) (for No. 1) → (C) (for No. 4)

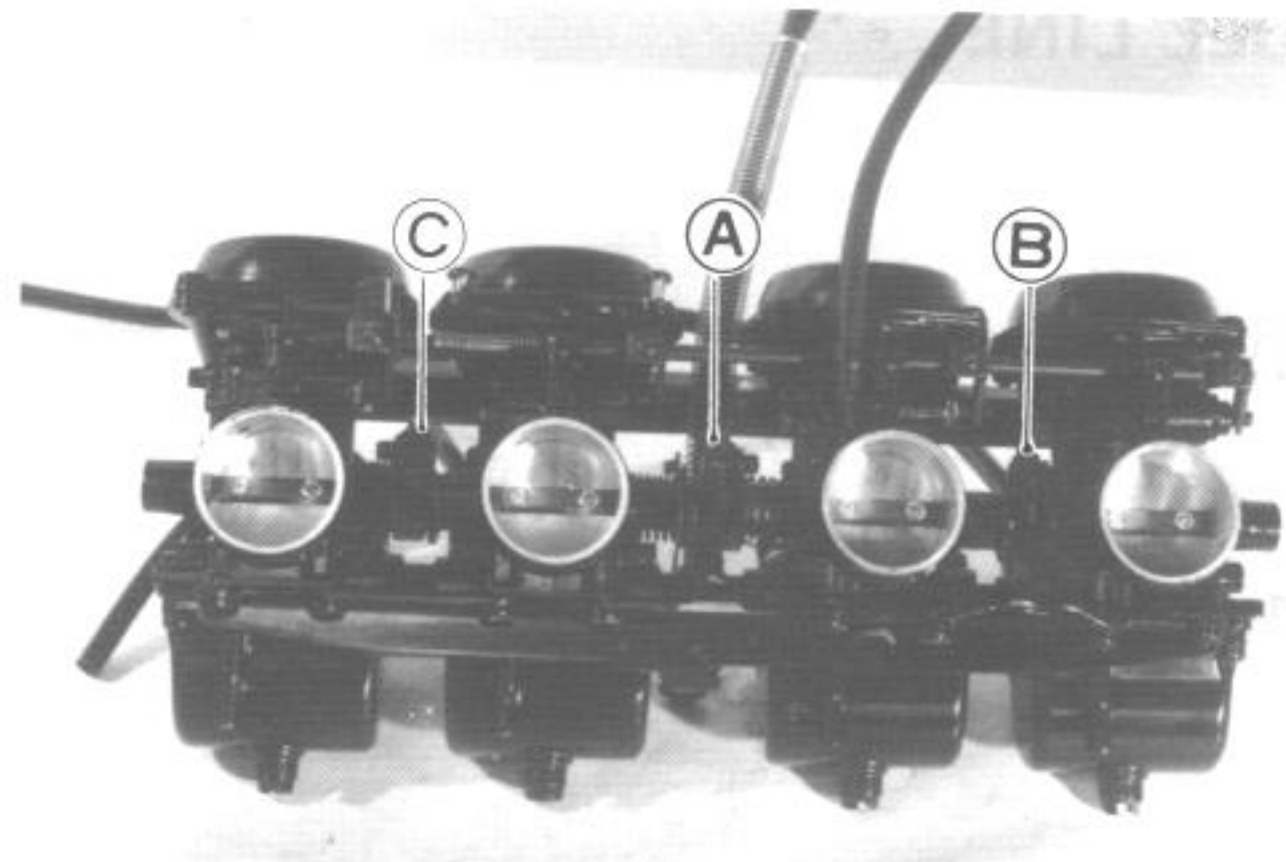

NOTE:

- * If an adjustment is required, it is suggested that the fuel tank is removed, and fuel should be supplied by a separate fuel tank.
- * Be sure to plug the fuel cock vacuum line.
- * Each vacuum inlet screw has a gasket. Be careful not to leave out this gasket ②.

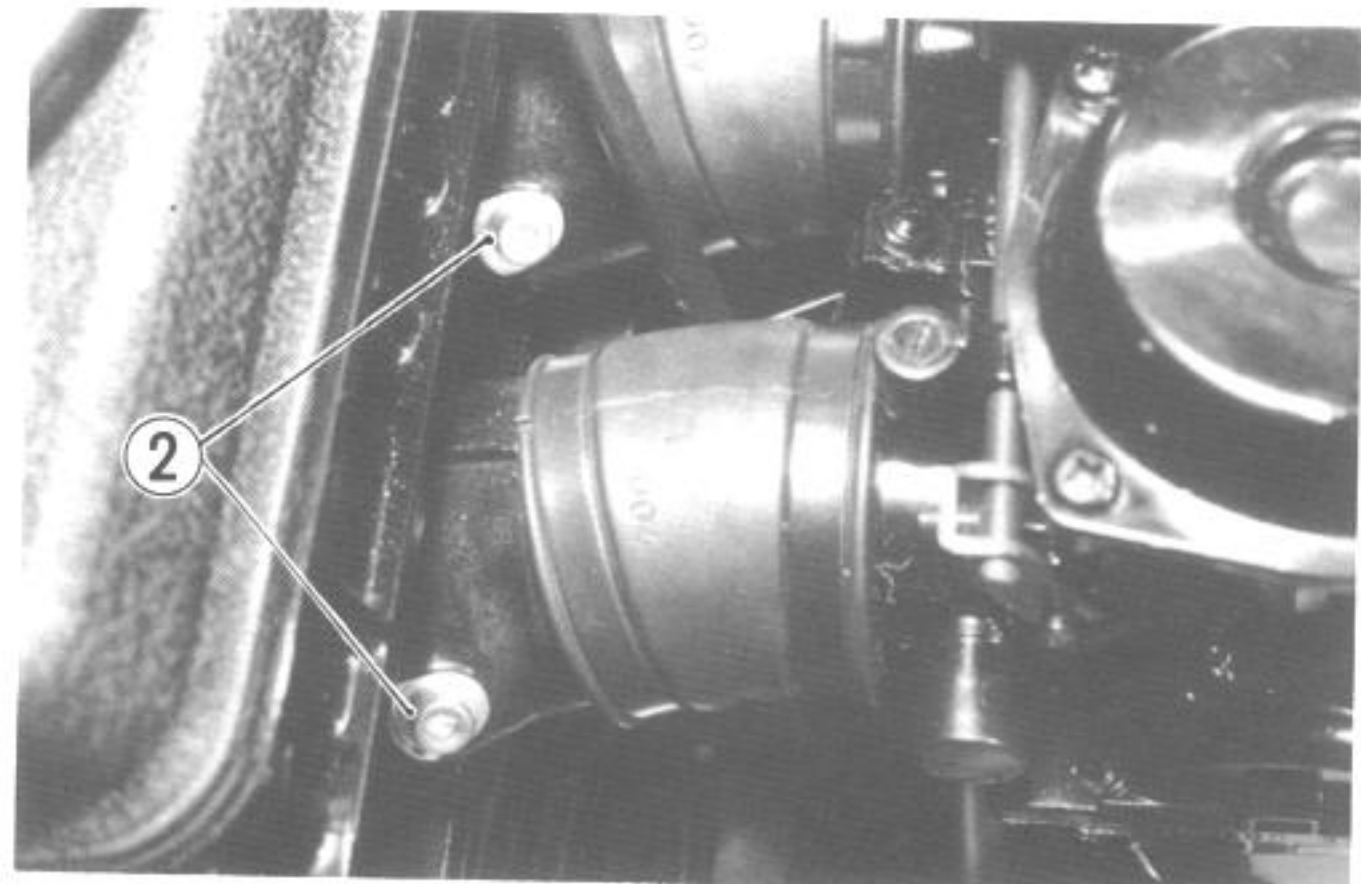

Oil
Filter
Over

IDLING ADJUSTMENT

NOTE:

Make this adjustment when the engine is hot.

- After balancing carburetors, set its speed at anywhere between 1 050 and 1 150 r/min by turning throttle stop screw.

CAUTION:

Do not disturb the pilot screws ①. This component is pre-set at the factory by the very specialized equipment.

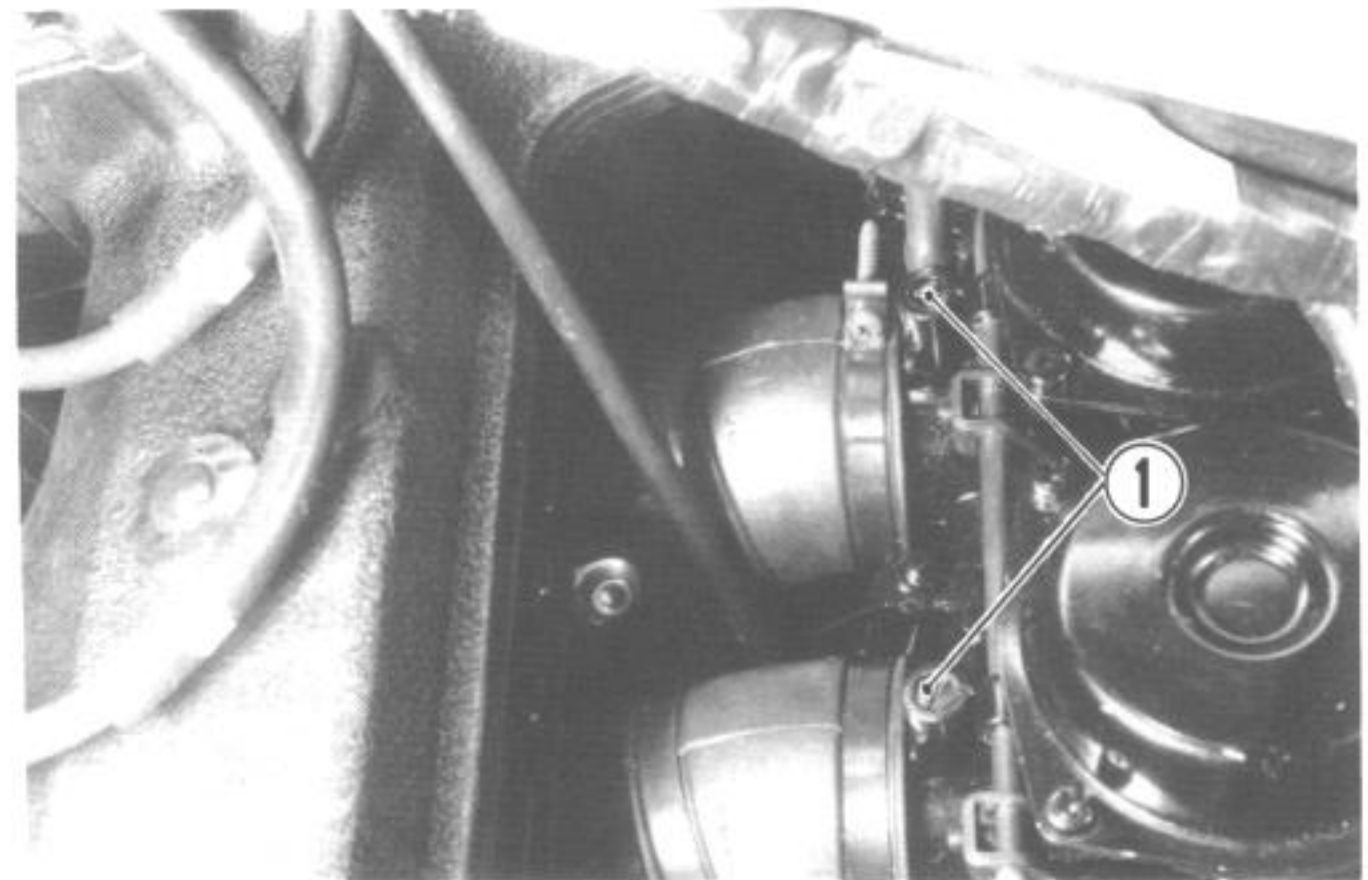

FUEL LINE

Inspect initial 1 000 km (600 mi) and
Every 5 000 (3 000 mi) km.
Replace every 4 years

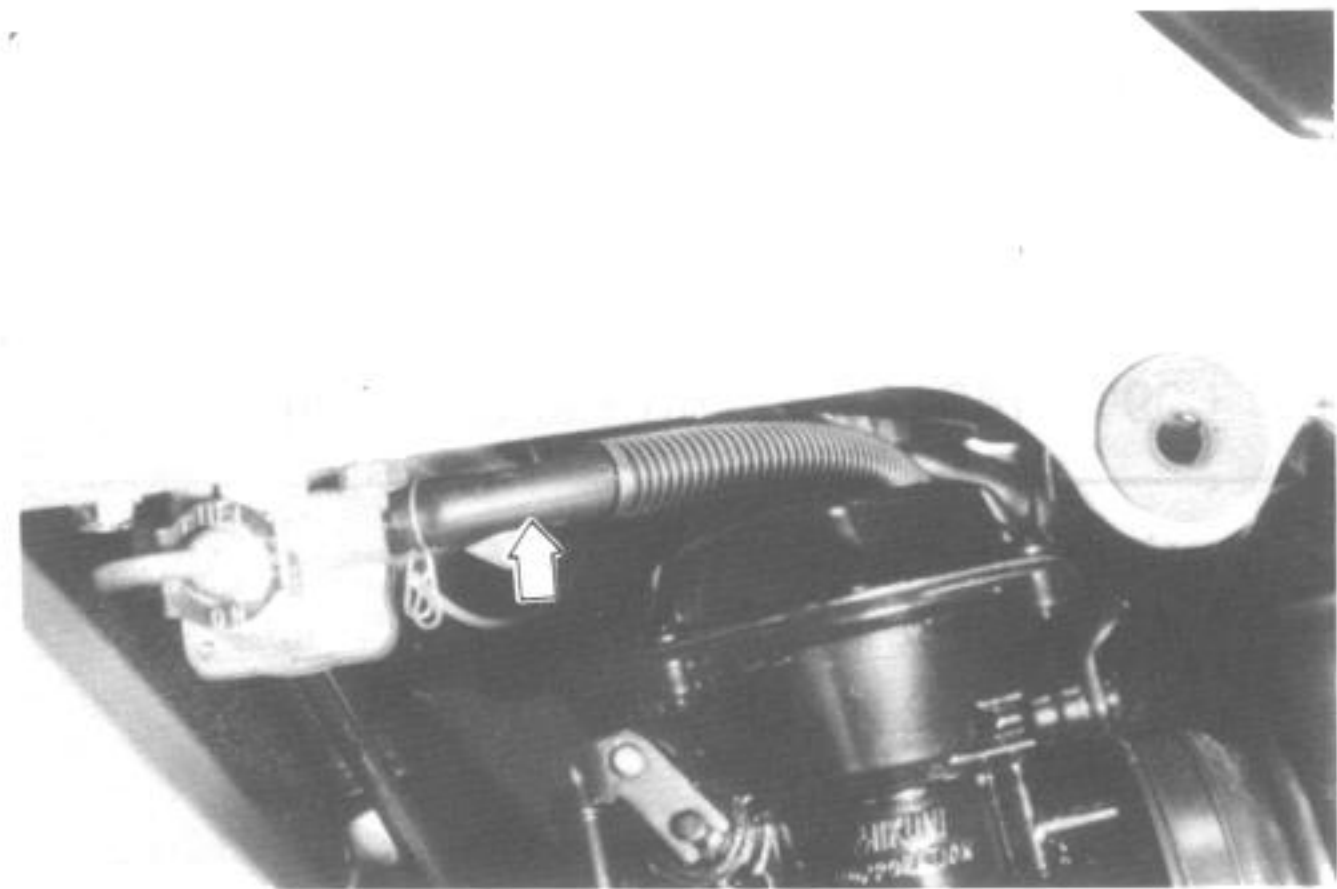

EN
F
E
The
Oil
be o
• K
ce
• P
th
②
• R
co
• P
• R
③
NO
*
*
• Fi
thr
3 6
Use
10
• Sta
sev
• Tu
the
win
ad
NECE
Oil
Filt
Ove

ENGINE OIL AND OIL FILTER

Replace Initial 1 000 km (600 mi) and Every 5 000 km (3 000 mi).

The oil should be changed while the engine is hot. Oil filter replacement at the above intervals should be done together with engine oil change.

- Keep the motorcycle upright, supported on the center stand.
- Place an oil pan below the engine and remove the engine oil drain plug ① and oil filler cap ② to drain engine oil.
- Remove five nuts ③ and remove the filter cover.
- Pull out old filter ④ and replace with new one.
- Replace O-ring and filter cover, and secure nuts ③ with applying thread lock cement.

99000-32040

Thread lock cement

NOTE:

- * Thoroughly clean the mating surface ① and groove ② of filter cover.
 - * Be sure to take care of O-ring ③ to prevent any damage and be sure that filter spring ④ is properly in place.
- Fit drain plug ① securely, and add fresh oil through the filler. The engine will hold about 3 600 ml of oil. Use API classification of SE or SF oil with SAE 10W/40 viscosity.
 - Start up the engine and allow it to run for several seconds at idling speed.
 - Turn off the engine and wait about one minute, then check the oil level through the inspection window ⑦. If the level is below mark "F", add oil to that level.

NECESSARY AMOUNT OF ENGINE OIL

Oil change	3 200 ml
Filter change	3 600 ml
Overhaul engine	4 000 ml

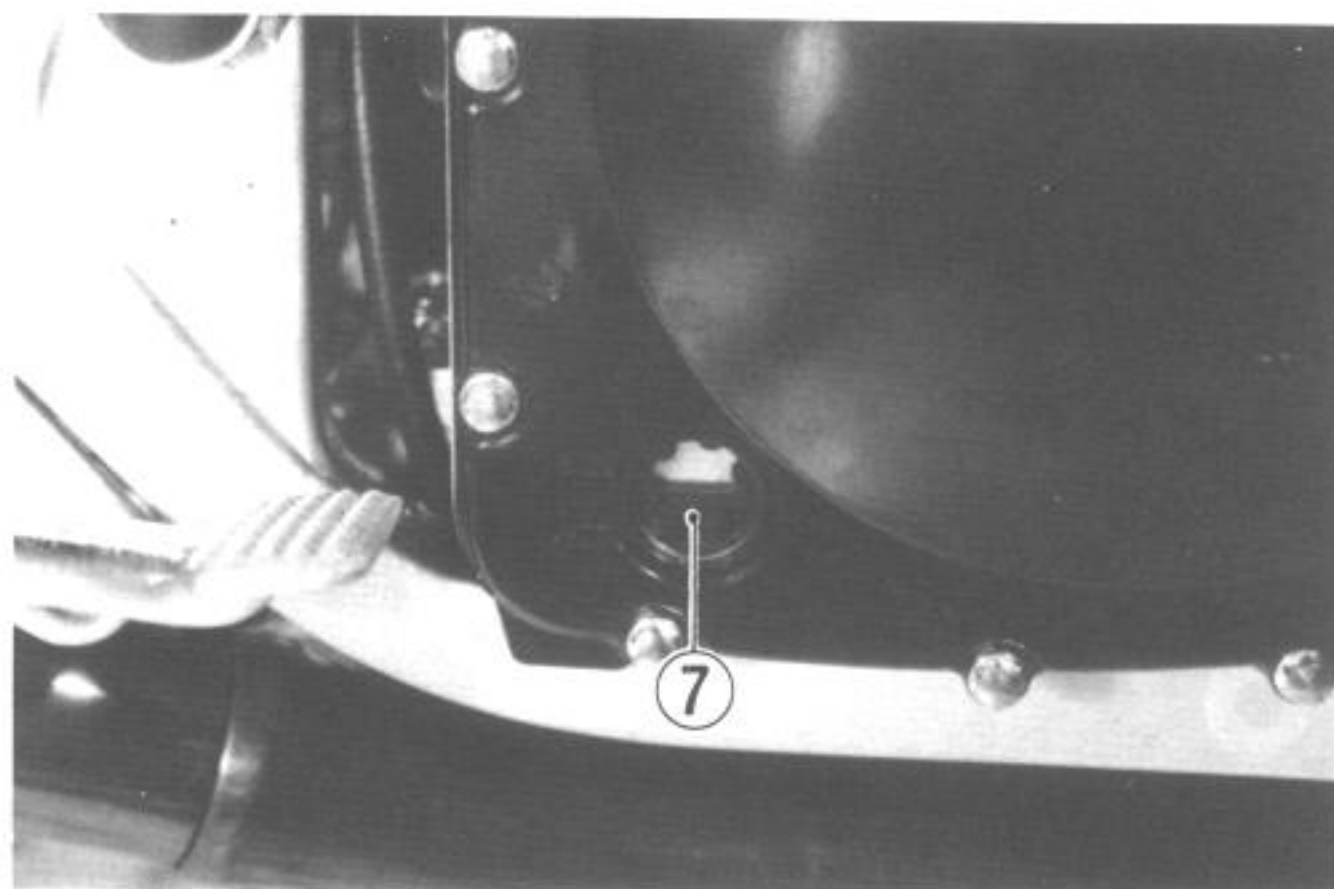
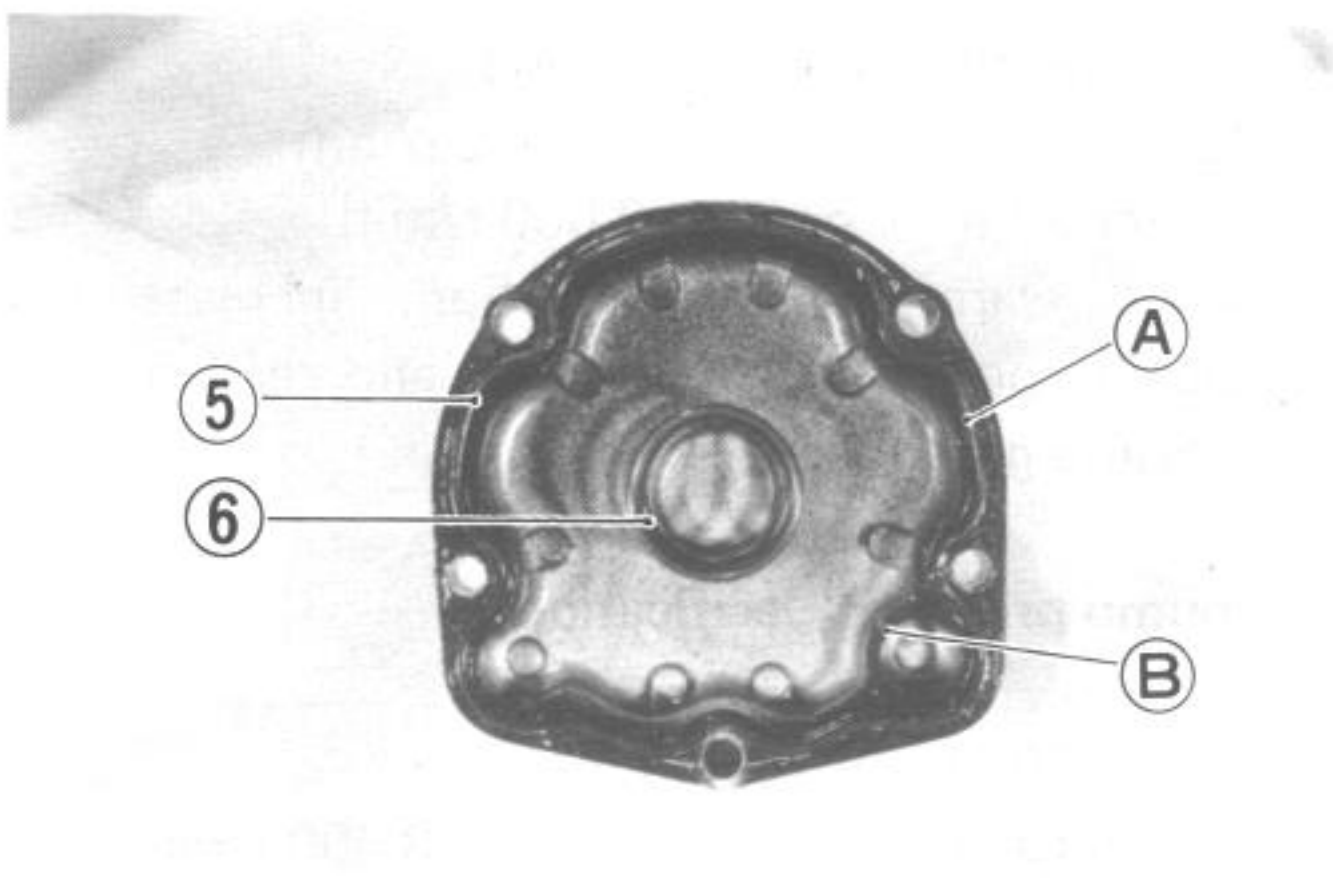
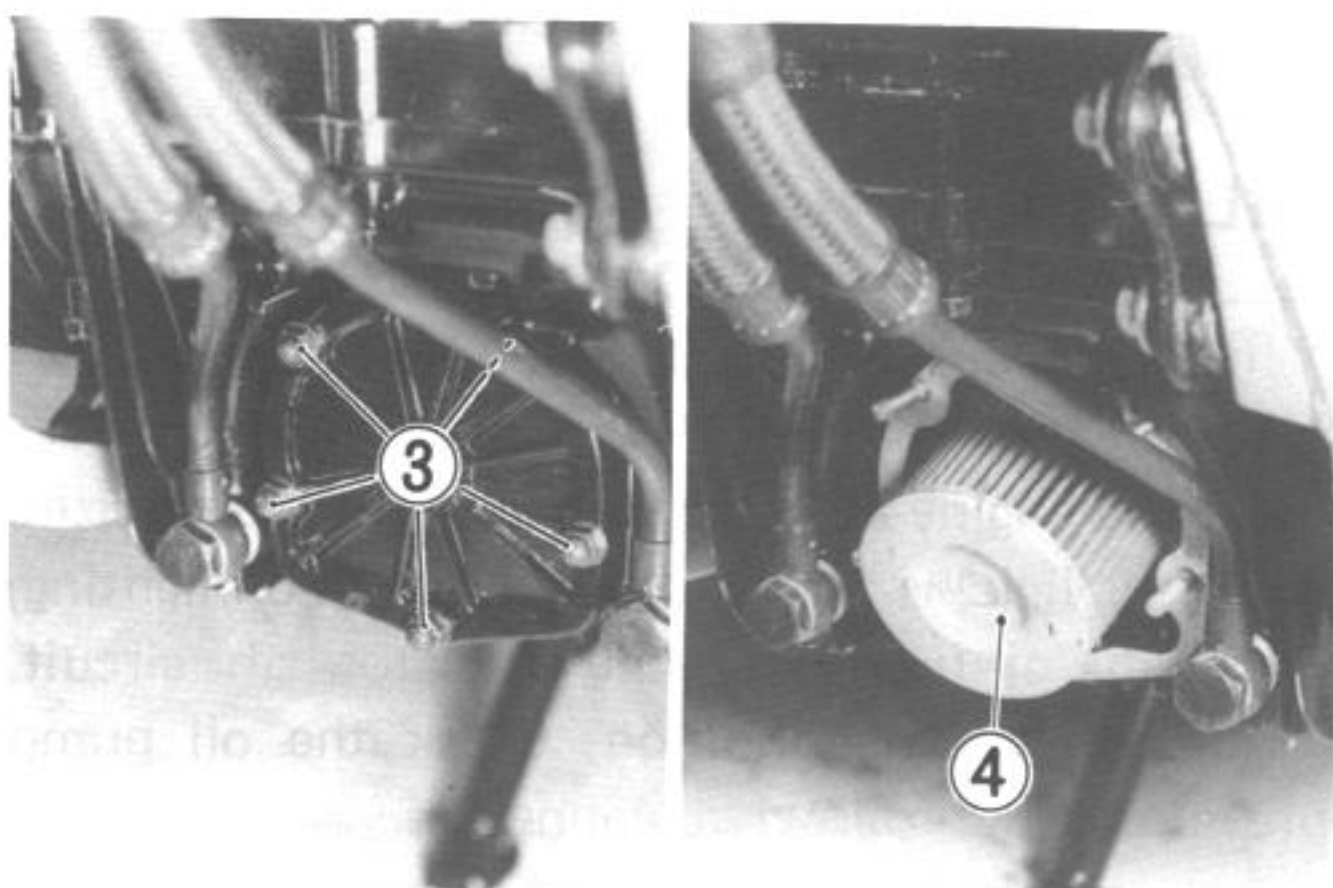
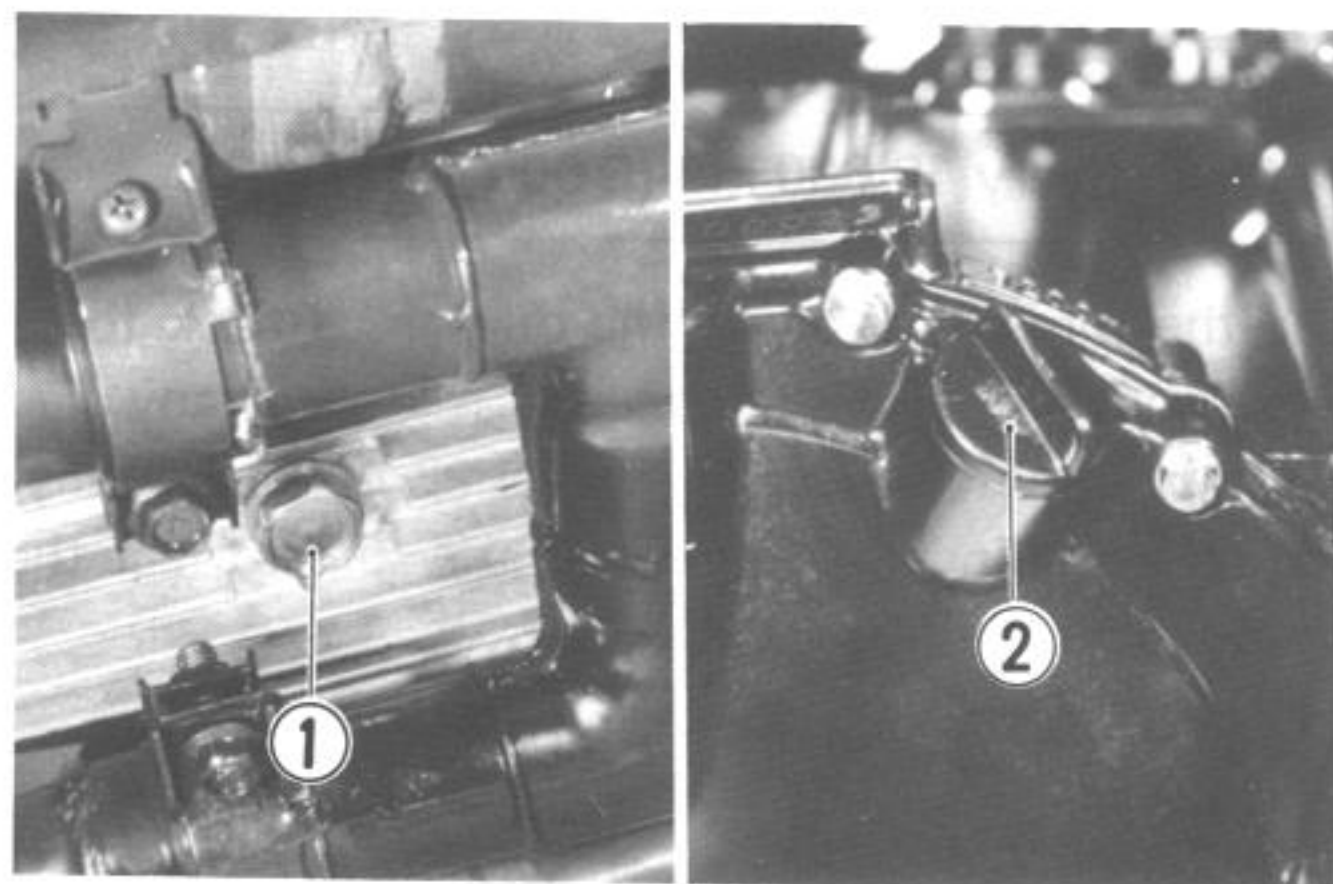

OIL SUMP FILTER

Clean Every 10 000 km (6 000 mi)

At the same time wash the oil pan. Check to be sure that the strainer screen is free from any sign of rupture and wash the strainer clean periodically. When installing oil sump filter, be sure to face the oil inlet to the front.

NOTE:

Replace oil pan gasket with new one to prevent oil leakage.

OIL PRESSURE

Inspect Every 5 000 km (3 000 mi)

Start the engine and check if the oil pump pressure indicator light is turned on. If it keeps on lighting, check the oil pump pressure indicator light circuit. If it is in good condition, check the oil pump pressure in the following manner:

- Install the oil pressure gauge in the position shown in the figure.
- Warm up the engine as follows:
Summer 10 min. or so at 2 000 r/min
Winter 20 min. or so at 2 000 r/min
- After warming up operation, increase the engine speed to 3 000 r/min, and read the oil pressure gauge.

Oil pump pressure specification

Above 20 kPa (0.20 kg/cm²),
Below 40 kPa (0.40 kg/cm²) at 3 000 r/min

09915-74510

Oil pressure gauge

If the oil pressure is lower or higher than the specifications, several causes may be considered.

- * Low oil pressure is usually the result of a clogged oil filter, oil leakage from the oil passageway, damaged oil seal, a defective oil pump or a combination of these items.

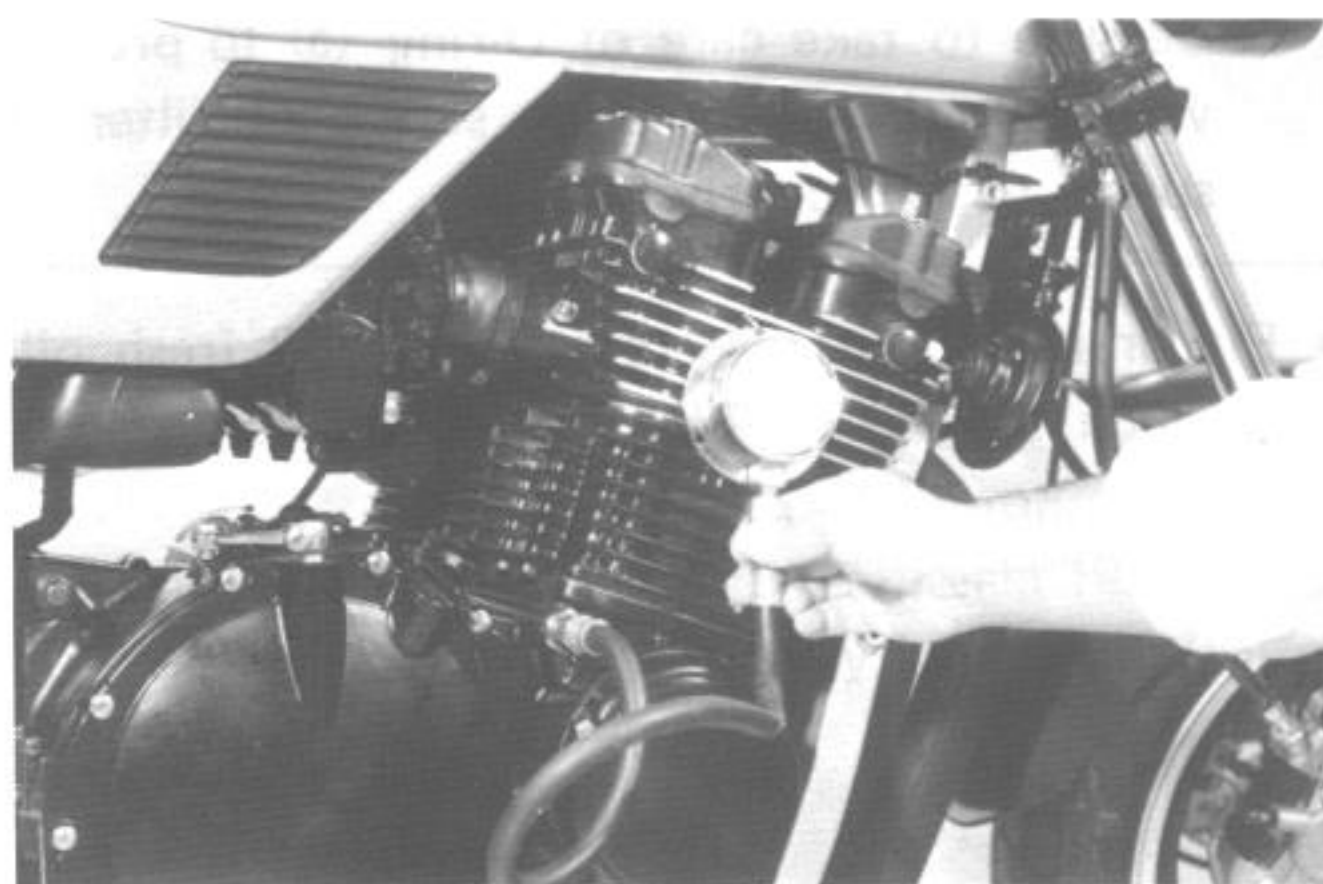
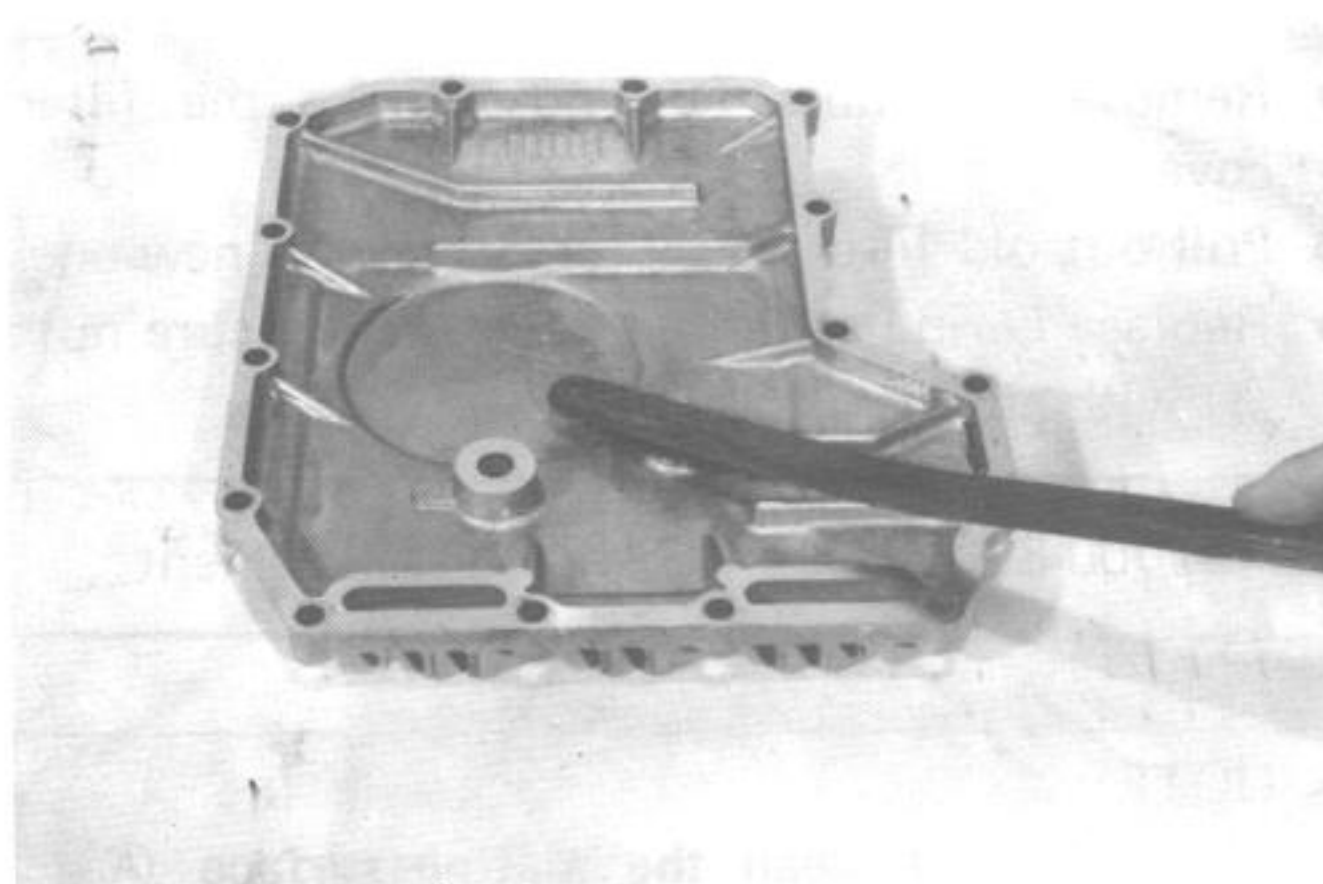
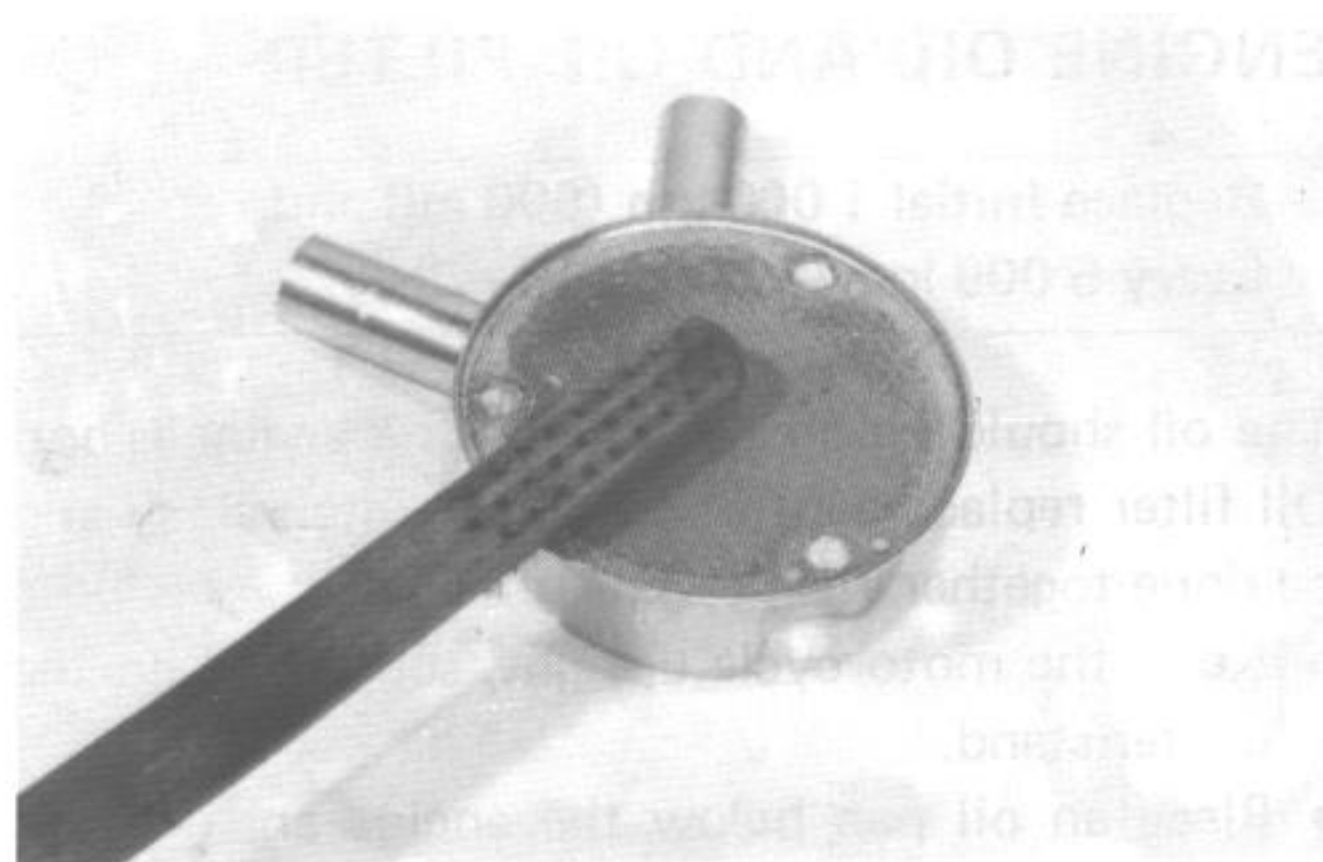

- * High oil pressure is usually caused by a engine oil which is too heavy a weight, a clogged oil passage, improper installation of the oil filter or a combination of these items.

CLU

Ins
Eve

- Lo
- clut
- the
- Loc
- to p
- play
- Ⓐ
- firm

Cal

- If th
- adju
- adju

DRIV

Inspr
Ever

Visually
possible
its cent
hand w
* Loos
* Dam
* Dry
* Kink
* Exce
* Impr
* Missi
If any
replac

CHECK

- Remo
- ④.
- Loose
- ⑥.
- Loose
- Tense
- adjust

CLUTCH

Inspect Initial 1 000 km (600 mi) and Every 5 000 km (3 000 mi)

- Loosen the lock nut ① on the lever side of the clutch cable and screw adjuster ② fully in on the clutch lever side.
- Loosen the cable lock nut, tighten the adjuster to provide play in the outer cable. Adjust the play of the cable with adjuster ③ until play ④ of the clutch lever is 2 – 3 mm. Next, firmly secure lock nut.

Cable play ④	2 – 3 mm
--------------	----------

- If the specified play can not be obtained with adjuster ③, carry out the adjustment using the adjuster ② on the clutch lever side.

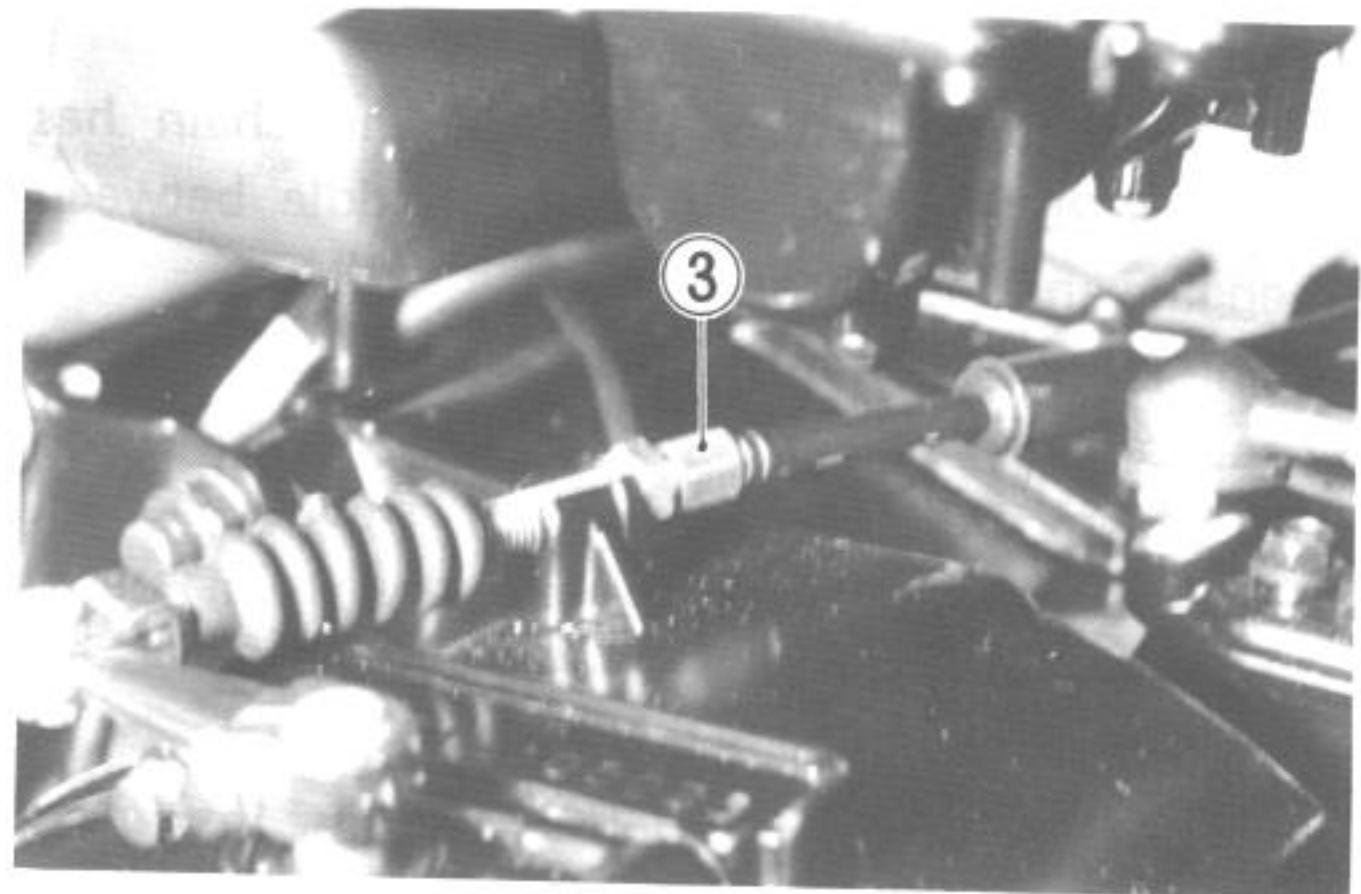
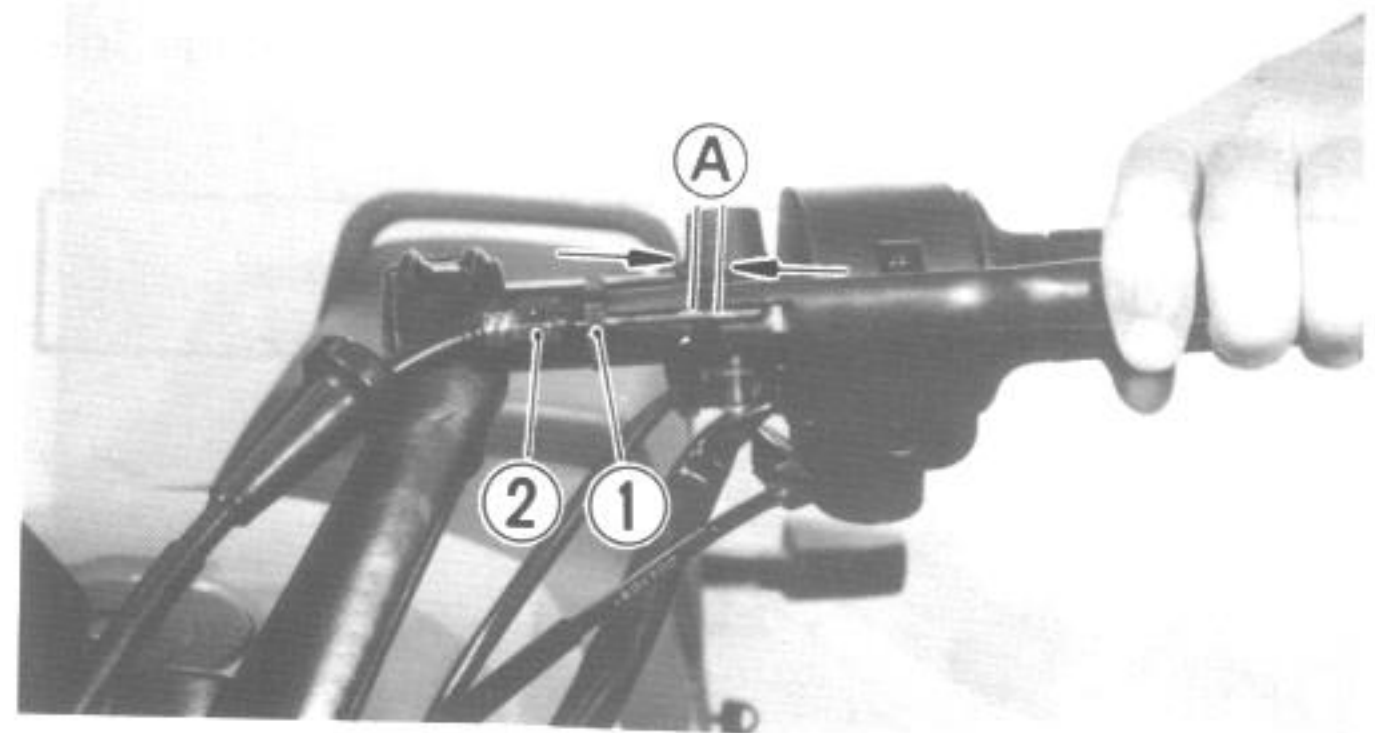

DRIVE CHAIN

Inspect and Clean Every 1 000 km (600 mi)

Visually check the drive chain for the below-listed possible malconditions. (Set up the machine on its center stand, and turn the rear wheel slowly by hand with the transmission shifted to Neutral.)

- * Loose pins
- * Damaged rollers
- * Dry or rusted links
- * Kinked or binding links
- * Excessive wear
- * Improper chain adjustment
- * Missing O-rings

If any defects are found, the drive chain must be replaced.

CHECKING

- Remove the screws and take off the axle caps ④.
- Loosen axle nut ⑤ after pulling out cotter pin ⑥.
- Loosen the lock nuts ⑦.
- Tense the drive chain fully by tightening the adjusters ⑧.

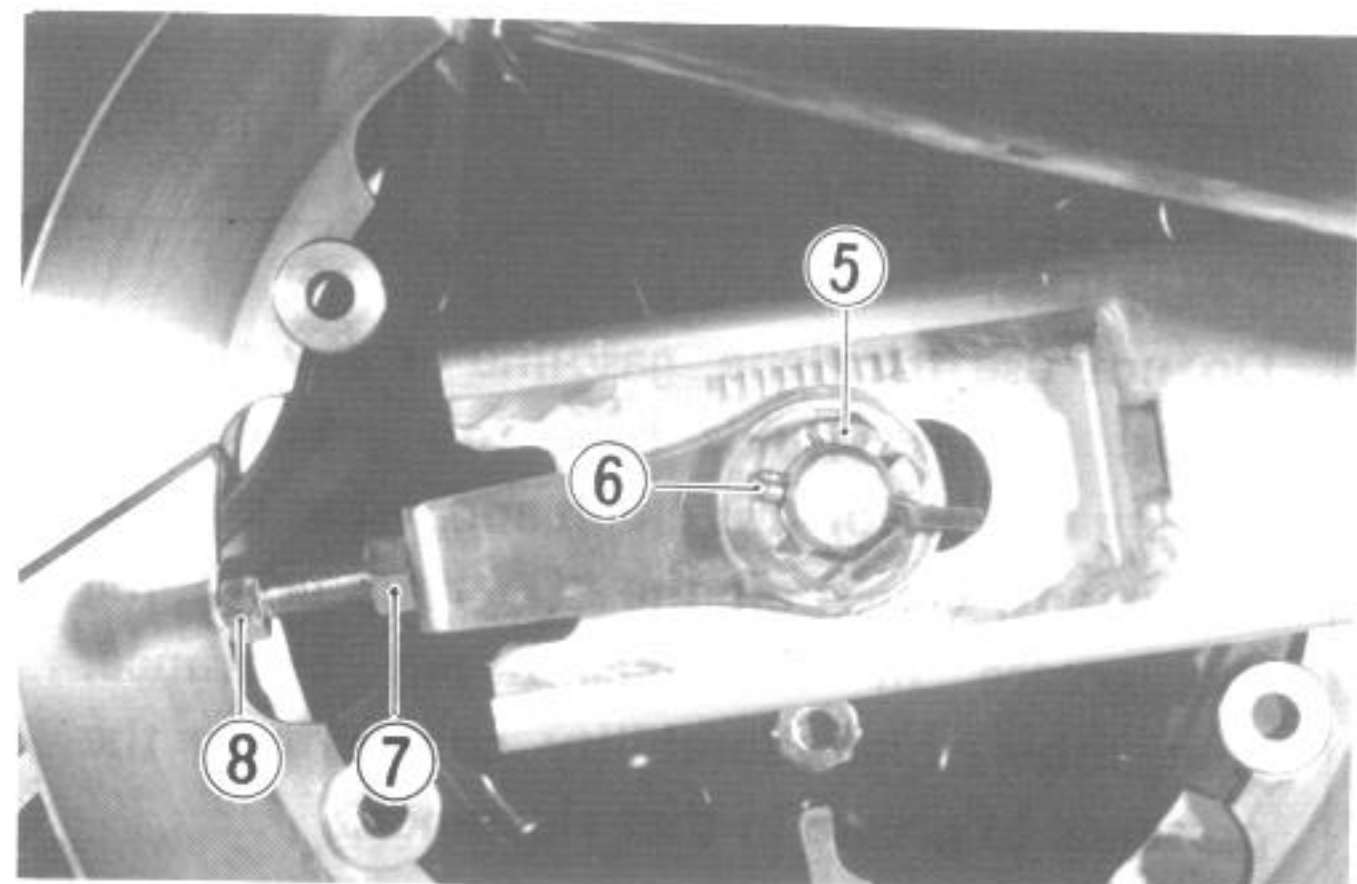

- Remove the chain case. Count out 21 pins (20 pitch) on the chain and measure the distance between the two. If the distance exceeds following limit, the chain must be replaced.

Service Limit	383.2 mm
---------------	----------

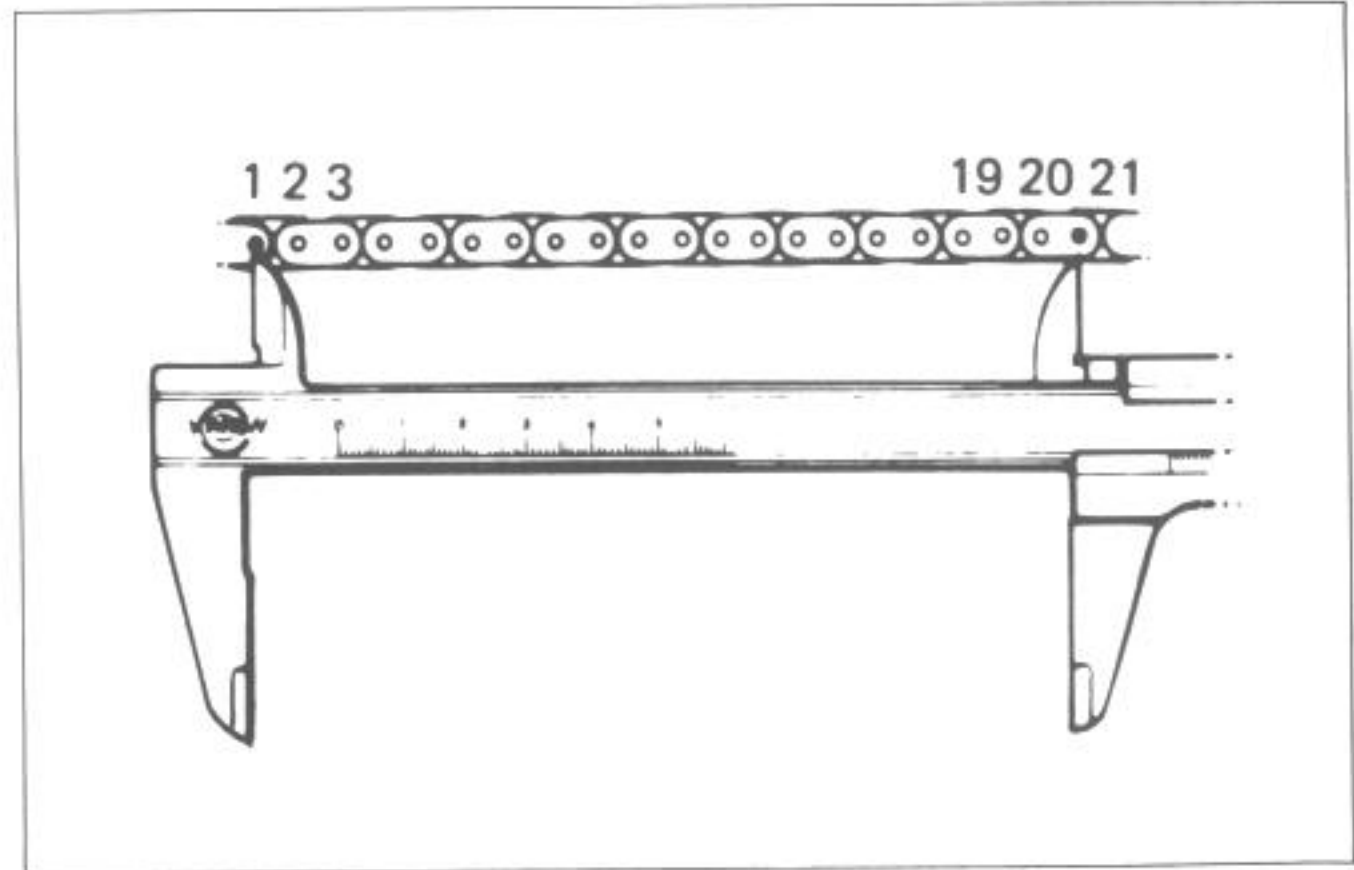

ADJUSTING

- Loosen the adjusters ① until the chain has 15 – 25 mm of sag at the middle between engine and rear sprockets. The mark ② on both chain adjusters must be at the same position on the scale to ensure that the front and rear wheels are correctly aligned.
- Place on center stand for accurate adjustment.

Standard	15 – 25 mm
----------	------------

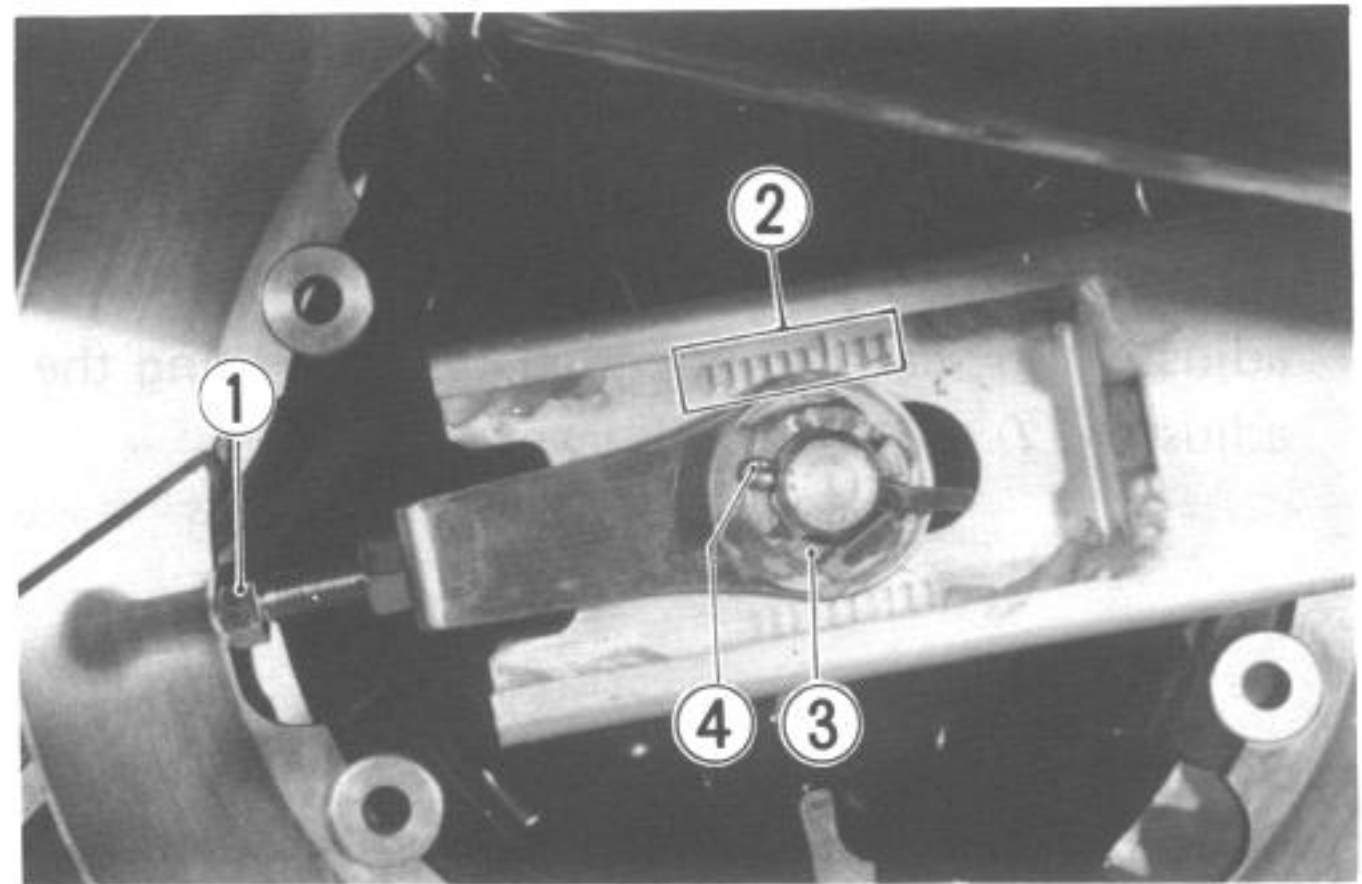

- After adjusting the drive chain, tighten the axle nut ③ securely, and lock with cotter pin ④. Always use a new cotter pin.
- Tighten the chain adjuster lock nuts good securely.

Rear axle nut tightening torque	85 – 115 N·m (8.5 – 11.5 kg-m)
---------------------------------	-----------------------------------

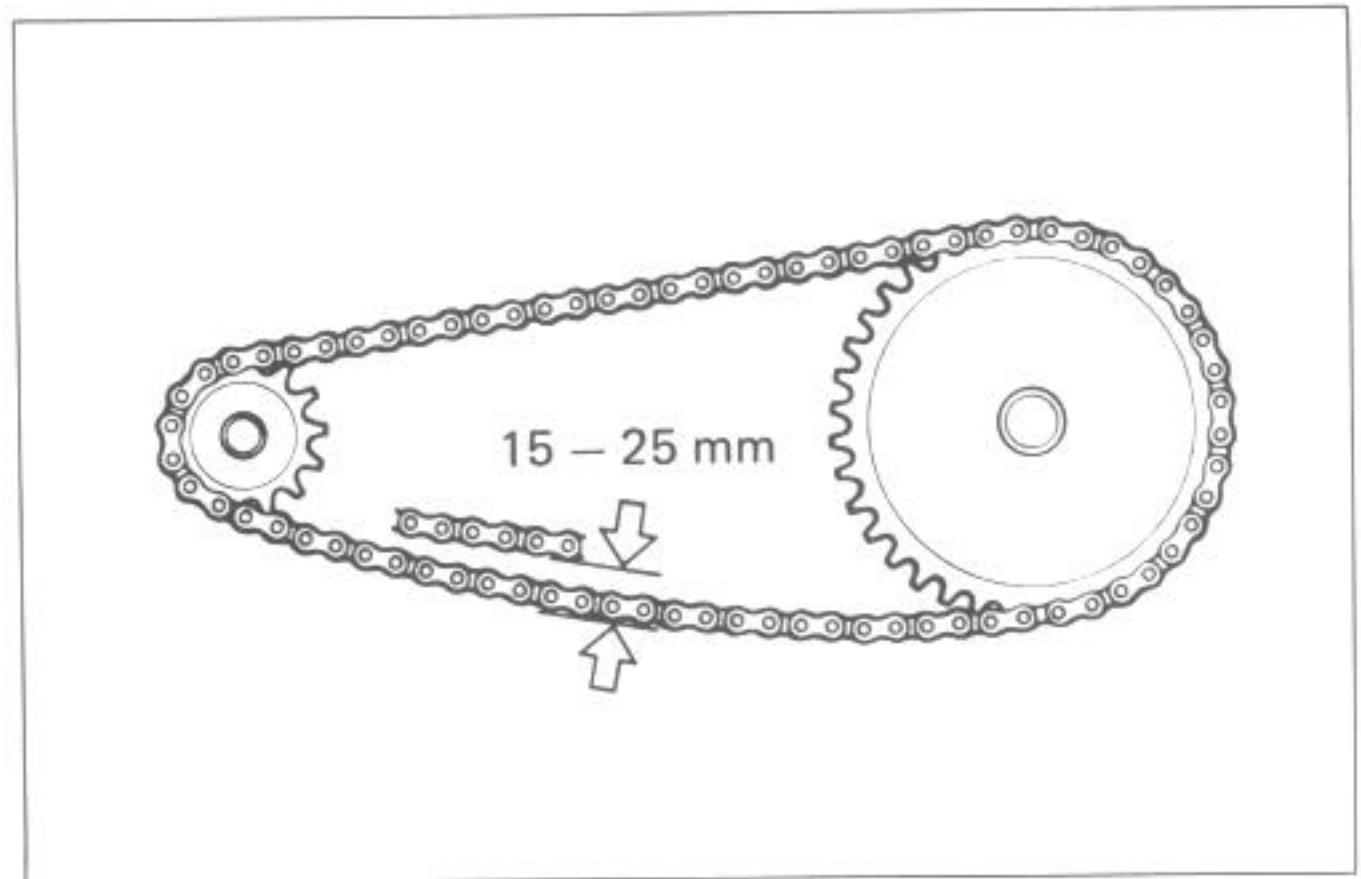

CLEANING AND LUBRICATING

Wash the chain with kerosene. If the chain tends to rust faster, the intervals must be shortened.

CAUTION:
Do not use trichlene, gasoline or any similar fluids: These fluids have too great a dissolving power for this chain and, what is more important, can spoil the "O" rings confining the grease in the bush-to-pin clearance. Remember, high durability comes from the presence of grease in that clearance.

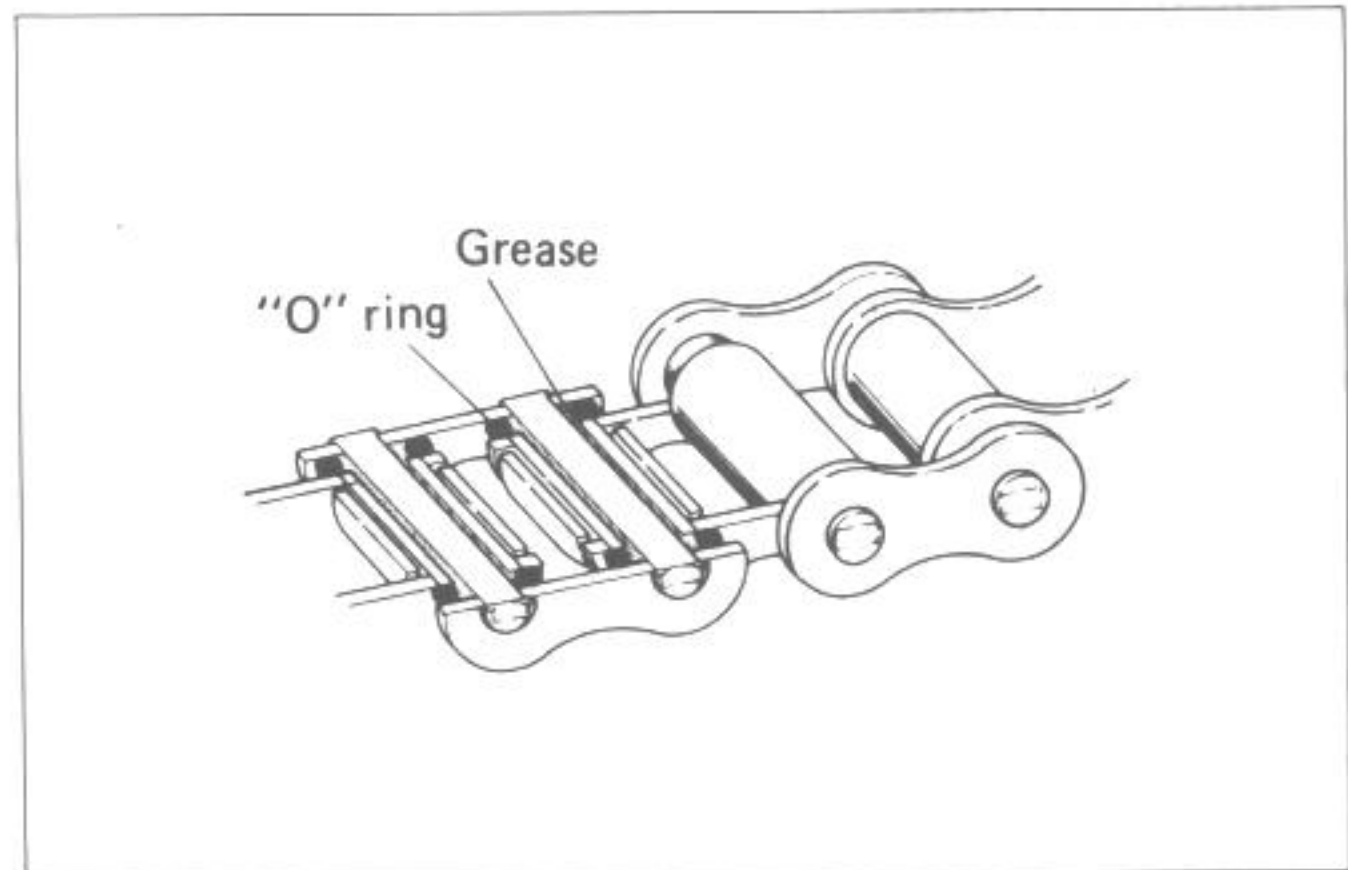

After
heav
W
Dr
"
"
CA
Th
YL
rec
sta
pla
BRA
Ins
Eve
Rep
Cha
BRAK
• Sup
sta
• Ren
• Che
low
both
• Whe
repl
ing s
Spe
and
99
WAF
The
with
or n
cone
refill
will
taken
taine
over
long

After washing and drying the chain, oil it with a heavy-weight motor oil.

WARNING:

Do not use any oil sold commercially as "drive chain oil". Such oil too can spoil the "O" rings.

CAUTION:

The standard drive chain is DAIDO DID630-YL or TAKASAGO RK630GSV. SUZUKI recommends that the above-mentioned standard drive chain be used for the replacement.

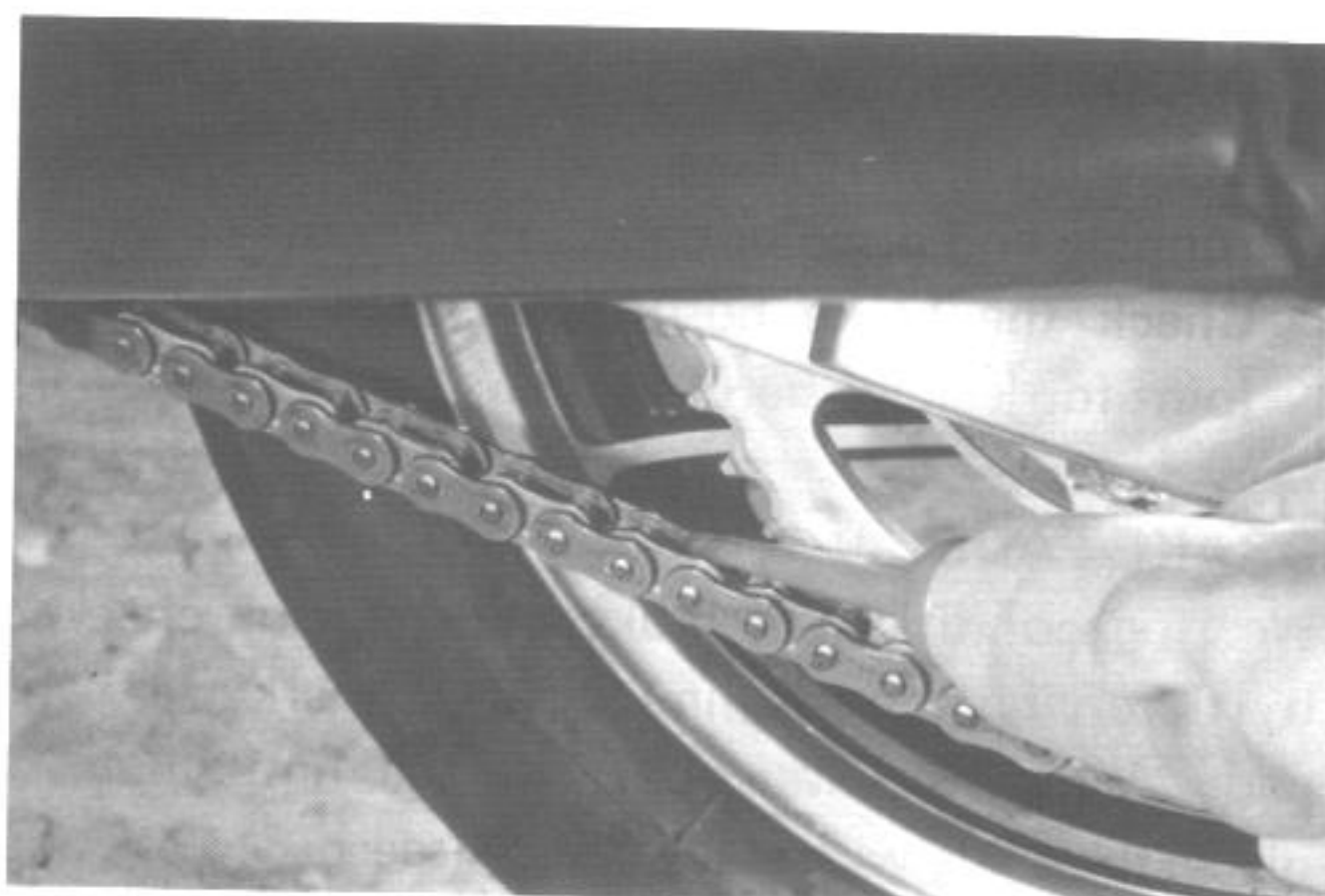

BRAKES

Inspect Initial 1 000 km (600 mi) and Every 5 000 km (3 000 mi)
 Replace hoses Every 4 years
 Change fluid Every 2 years

BRAKE FLUID LEVEL

- Support the motorcycle body on the center stand, and place the handlebars straight.
- Remove the right frame cover.
- Check the brake fluid level by observing the lower limit line on the brake fluid reservoirs, both front and rear.
- When the level is below the lower limit line, replenish with brake fluid that meets the following specification.

Specification and Classification	SAE J1703, DOT3, DOT4
99000-23021	SUZUKI Brake fluid

WARNING:

The brake system of this motorcycle is filled with a glycol-based brake fluid. Do not use or mix different types of fluid such as silicone-based and petroleum-based fluid for refilling the system, otherwise serious damage will be caused. Do not use any brake fluid taken from old or used or unsealed containers. Never re-use the brake fluid left over from the last servicing and stored for long periods.

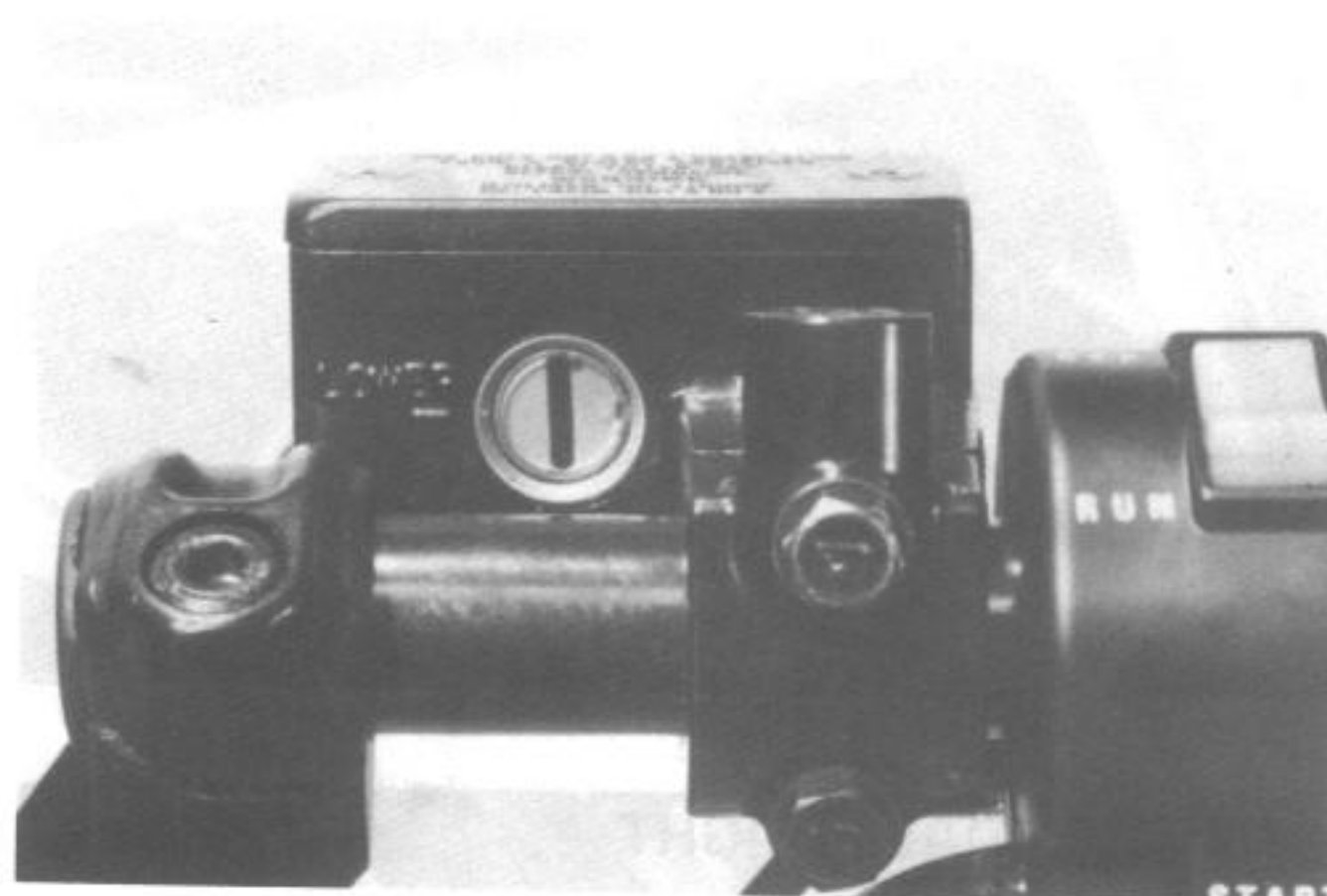

WARNING:

Brake fluid, if it leaks, will interfere with safe running and discolor painted surfaces. Check the brake hoses for cracks and hose joint for leakage before riding.

BRAKE PADS

Wearing condition of brake pads can be checked by observing the red limit line ① marked on the pad. When the wear exceeds the limit line, replace the pads with new ones. (see pages 6-8 and 6-30)

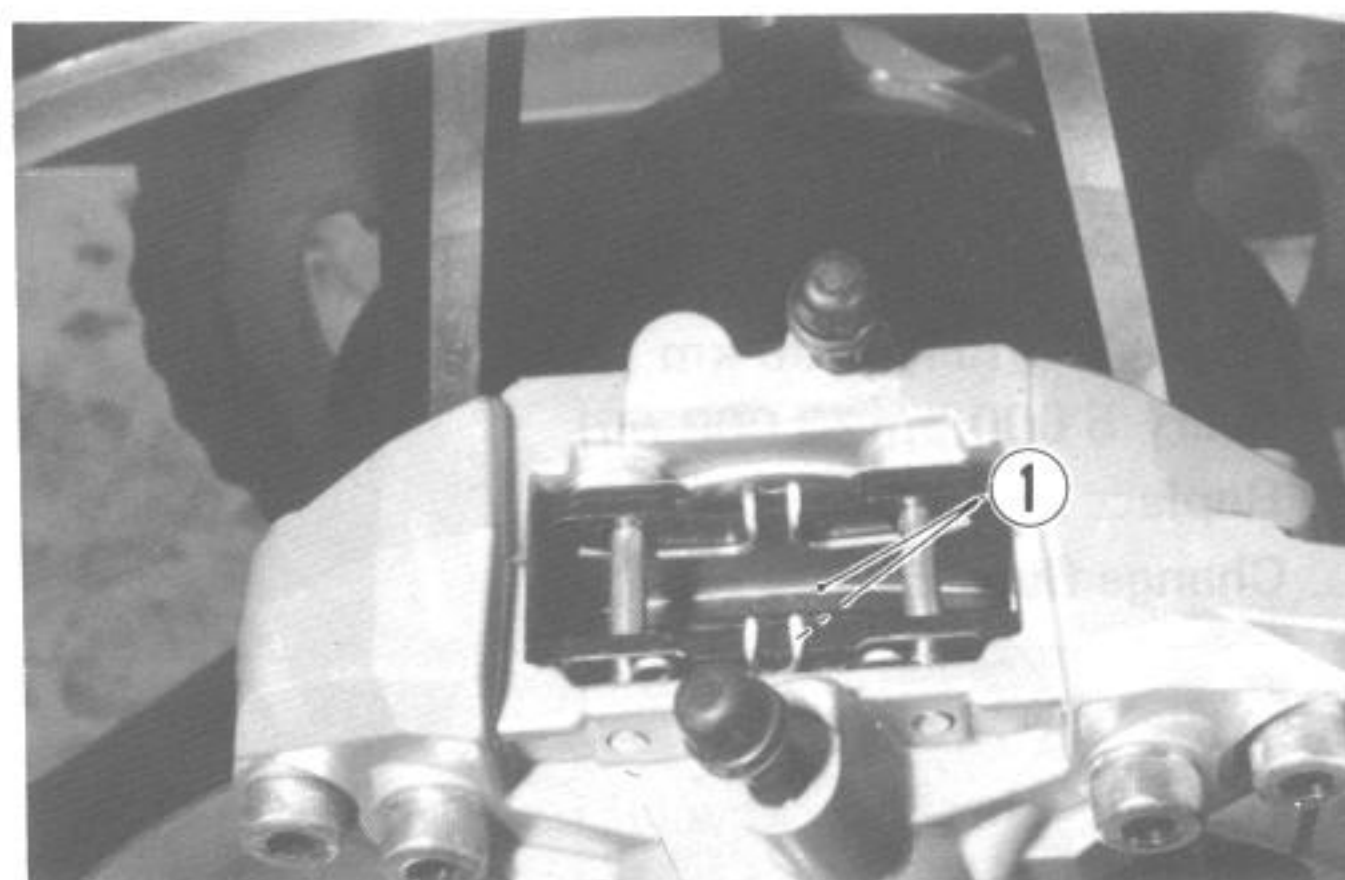
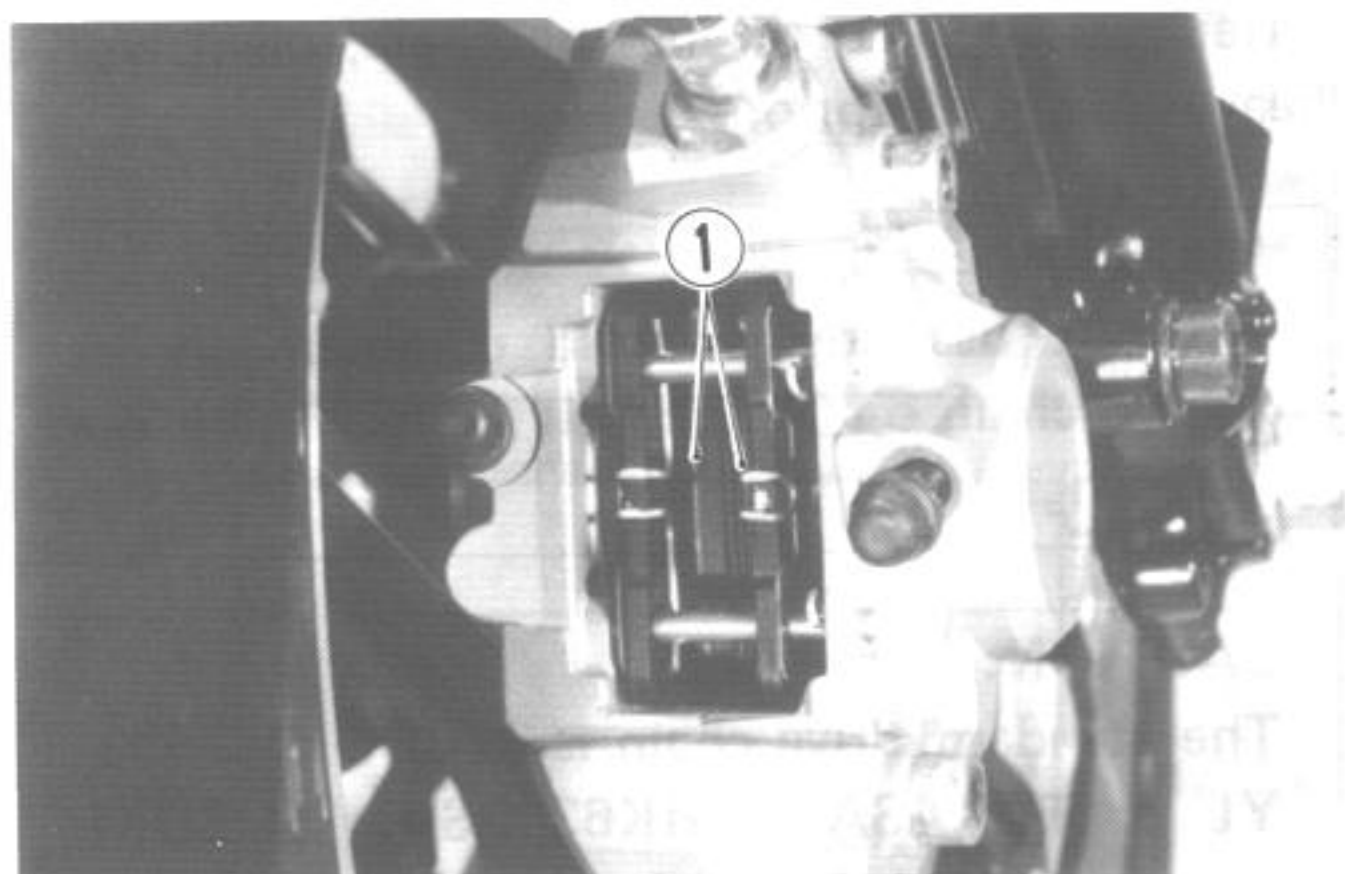

BRAKE PEDAL HEIGHT

- Loosen lock nut ①, and turn stopper bolt ② away from the stopper.
- Loosen lock nut ③, and rotate push rod ④ to locate brake pedal 40 mm below the top face of the footrest.
- Turn the stopper bolt ② in so that the clearance between the stopper bolt and stopper is zero.
- Retighten both lock nuts ① and ③.

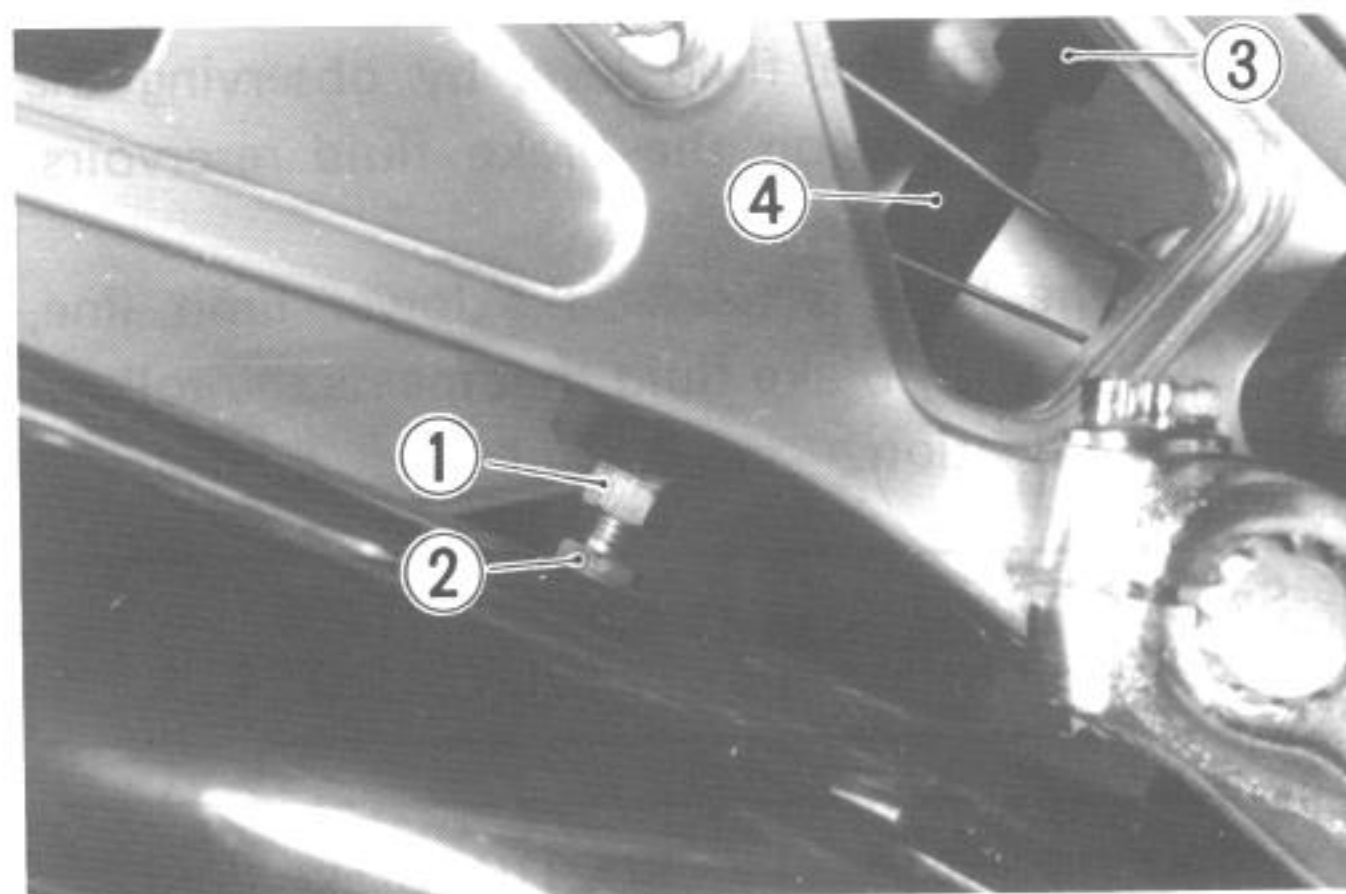

Brake pedal height	40 mm
--------------------	-------

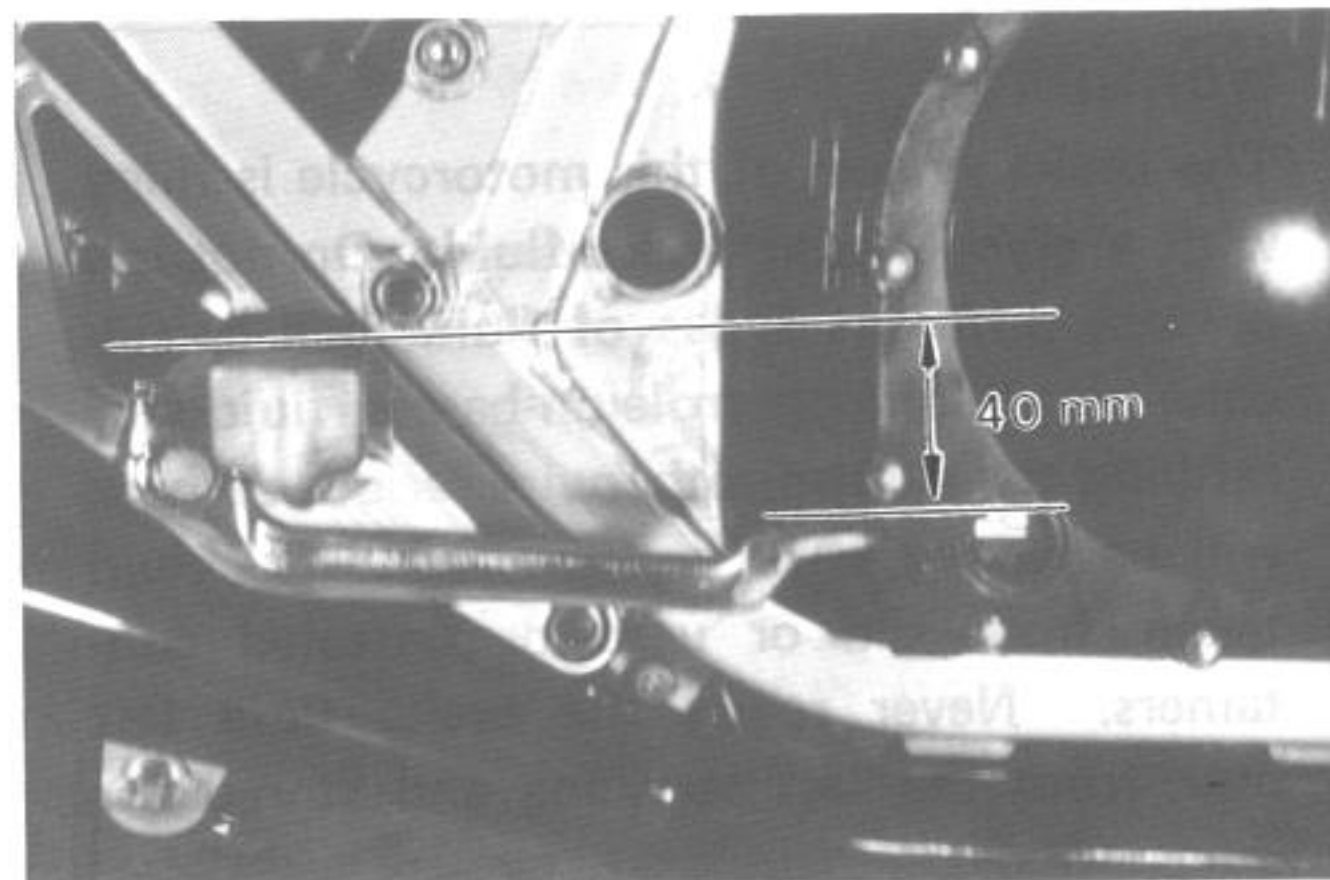

BR
Adj
tha
is f
bra

AIR
CIR
Air
to a
velo
with
brake
ness'
force
trapp
essen
restor
tion,
the fo
• Fil
tha
to
• Att
ins

Blee
tigh

BRAKE LIGHT SWITCHES

Adjust both brake light switches, front and rear, so that brake light will come on just before a pressure is felt when the brake lever is squeezed, or the brake pedal is depressed.

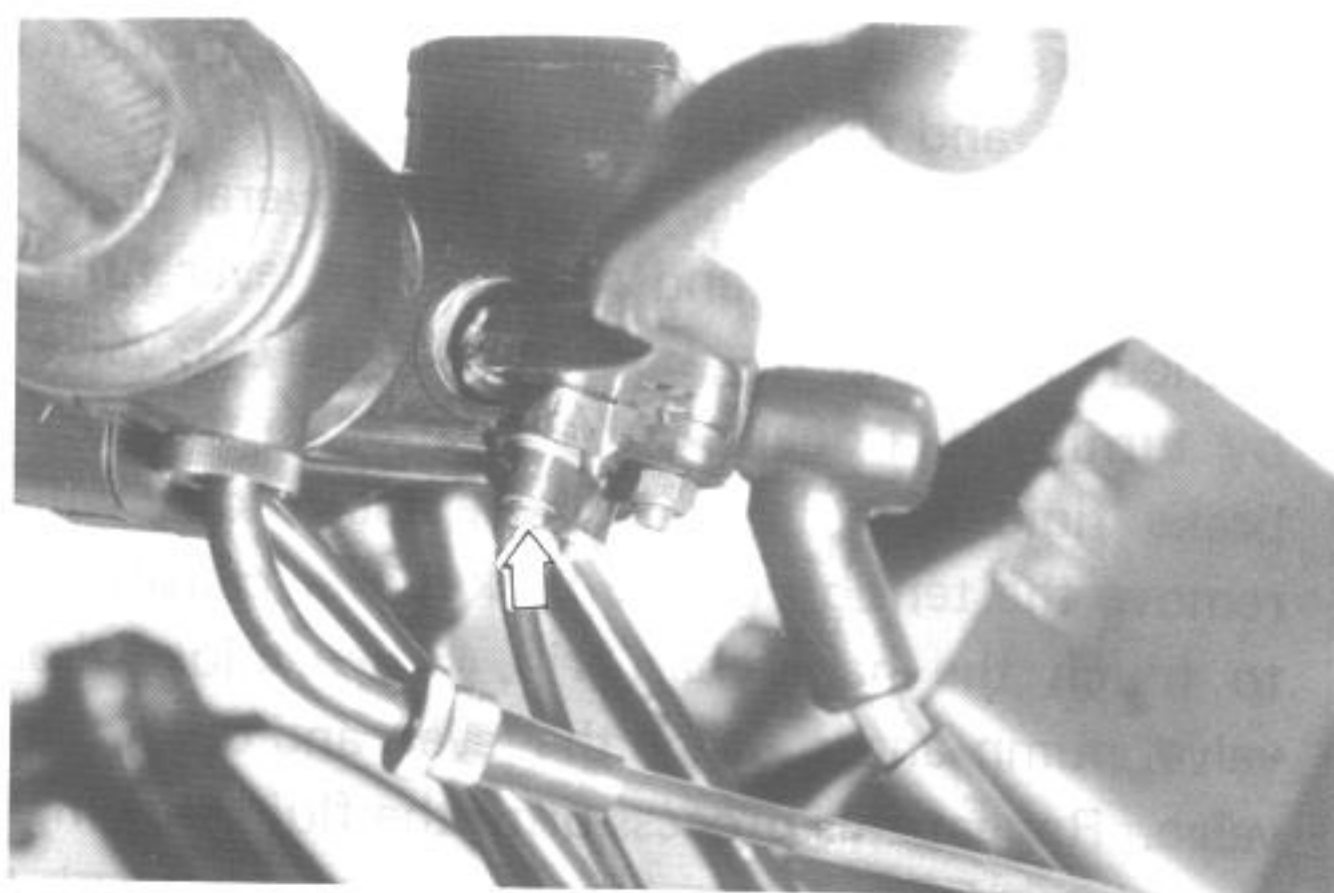

AIR BLEEDING THE BRAKE FLUID CIRCUIT

Air trapped in the fluid circuit acts like a cushion to absorb a large proportion of the pressure developed by the master cylinder and thus interferes with the full braking performance of the caliper brake. The presence of air is indicated by "sponginess" of the brake lever and also by lack of braking force. Considering the danger to which such trapped air exposes the machine and rider, it is essential that, after remounting the brake and restoring the brake system to the normal condition, the brake fluid circuit be purged of air in the following manner:

- Fill up the master cylinder reservoir to the more than lower level line. Replace the reservoir cap to prevent entry of dirt.
- Attach a pipe to the caliper bleeder valve, and insert the free end of the pipe into a receptacle.

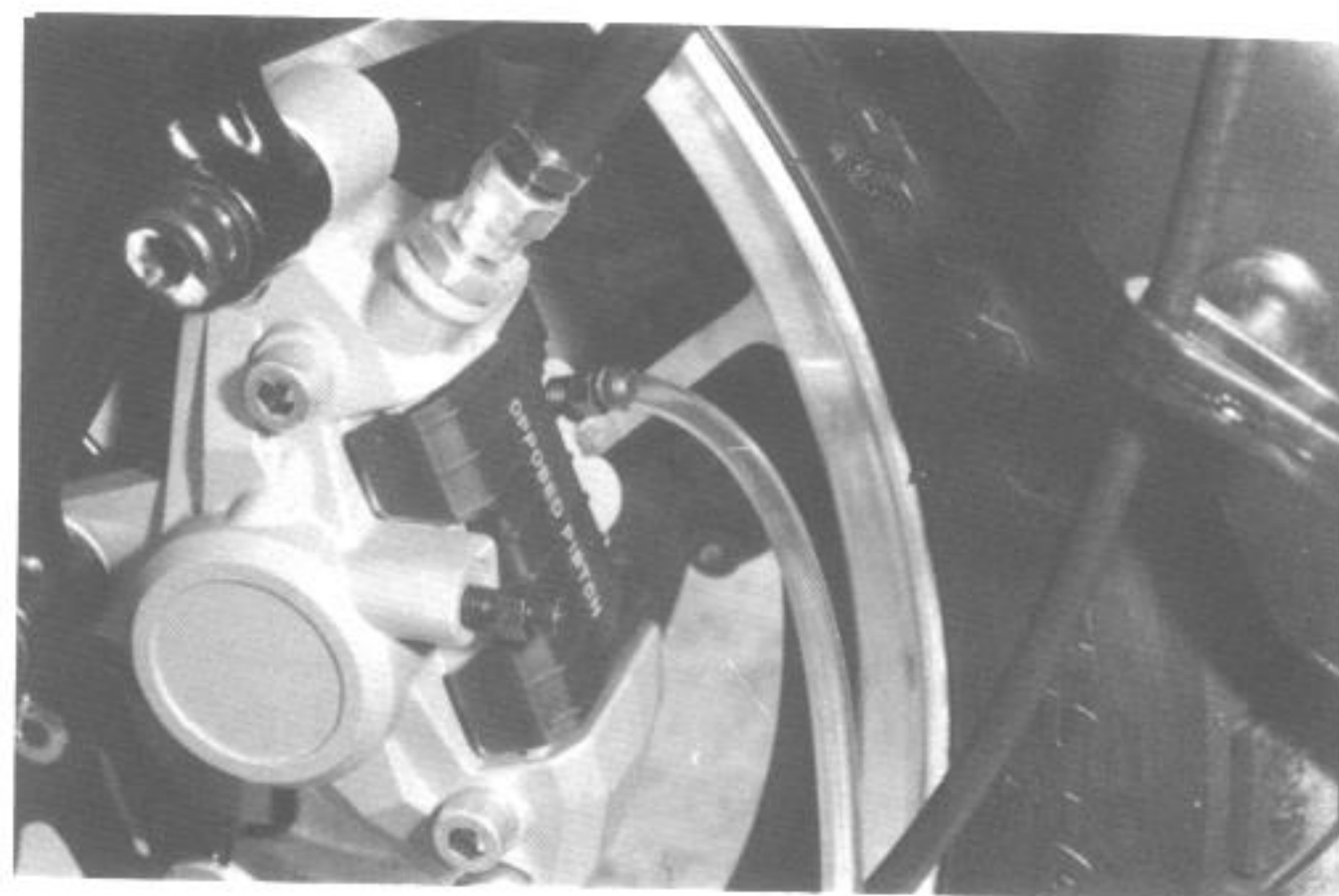

Bleeder valve tightening torque	6 – 9 N·m (0.6 – 0.9 kg-m)
------------------------------------	-------------------------------

- Front brake: Bleed the air from the inboard valve first, and then outboard valve.
- Squeeze and release the brake lever several times in rapid succession, and squeeze the lever fully without releasing it. Loosen the bleeder valve by turning it a quarter of a turn or so that the brake fluid runs into the receptacle; this will remove the tension of the brake lever causing it to touch the handlebar grip. Then, close the valve, pump and squeeze the lever, and open the valve. Repeat this process until the fluid flowing into the receptacle no longer contains air bubbles.

NOTE:

Replenish the brake fluid reservoir as necessary while bleeding the brake system. Make sure that there is always some fluid visible in the reservoir.

- Close the bleeder valve, and disconnect the pipe. Fill the reservoir to the more than lower level line.

CAUTION:

Handle the brake fluid with care: the fluid reacts chemically with paint, plastics, rubber materials, etc.

- Rear brake: Differences between front and rear are that the master cylinder is actuated by a pedal.

TIRES

Inspect Initial 1 000 km (600 mi) and Every 5 000 km (3 000 mi)

TIRE TREAD CONDITION

Operating the motorcycle with the excessively worn tires will decrease riding stability and consequently invite a dangerous situation. It is highly recommended to replace the tire when the remaining depth of tire tread reaches the following specifications.

FRONT	REAR
1.6 mm	2.0 mm

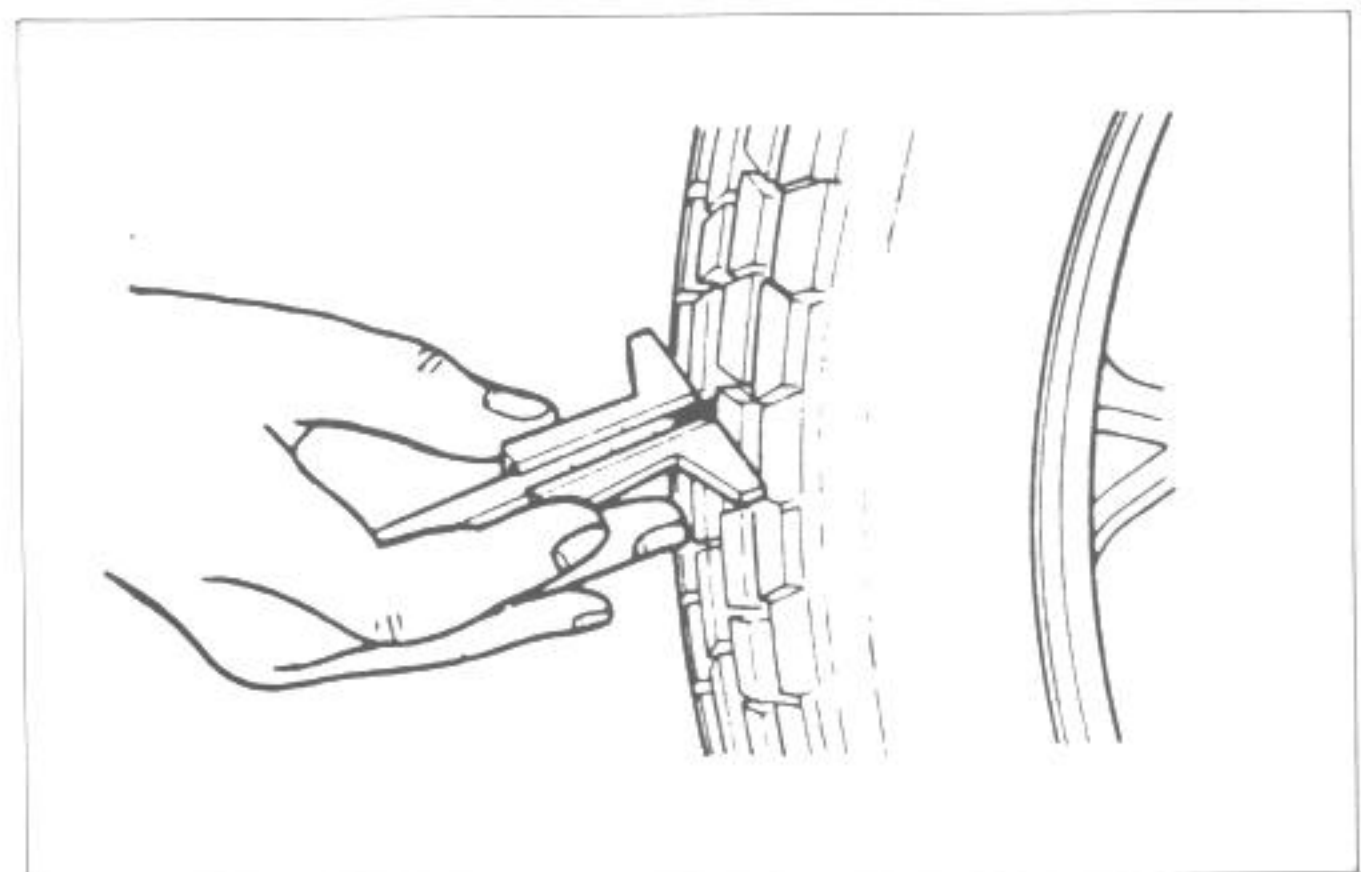

TIR
If th
will
Ther
good
Colu

Sol
Du

CA
Th
11
rea
arc
co

STE

Ins
Eve

Taper
ing sy
Steer
manip
Too s
handl
stabil
Check
assembl
front
ahead,
pull f
bearing
this m

TIRE PRESSURE

If the tire pressure is too high or too low, steering will be adversely affected and tire wear increased. Therefore, maintain the correct tire pressure for good roadability or shorter tire life will result. Cold inflation tire pressure is as follows:

	FRONT		REAR	
	kPa	kg/cm ²	kPa	kg/cm ²
Solo riding	250	2.50	250	2.50
Dual riding	250	2.50	290	2.90

CAUTION:

The standard tire fitted on this motorcycle is 110/90 V16 for front and 130/90 V17 for rear. The use of a tire other than the standard may cause instability. It is highly recommended to use a SUZUKI Genuine Tire.

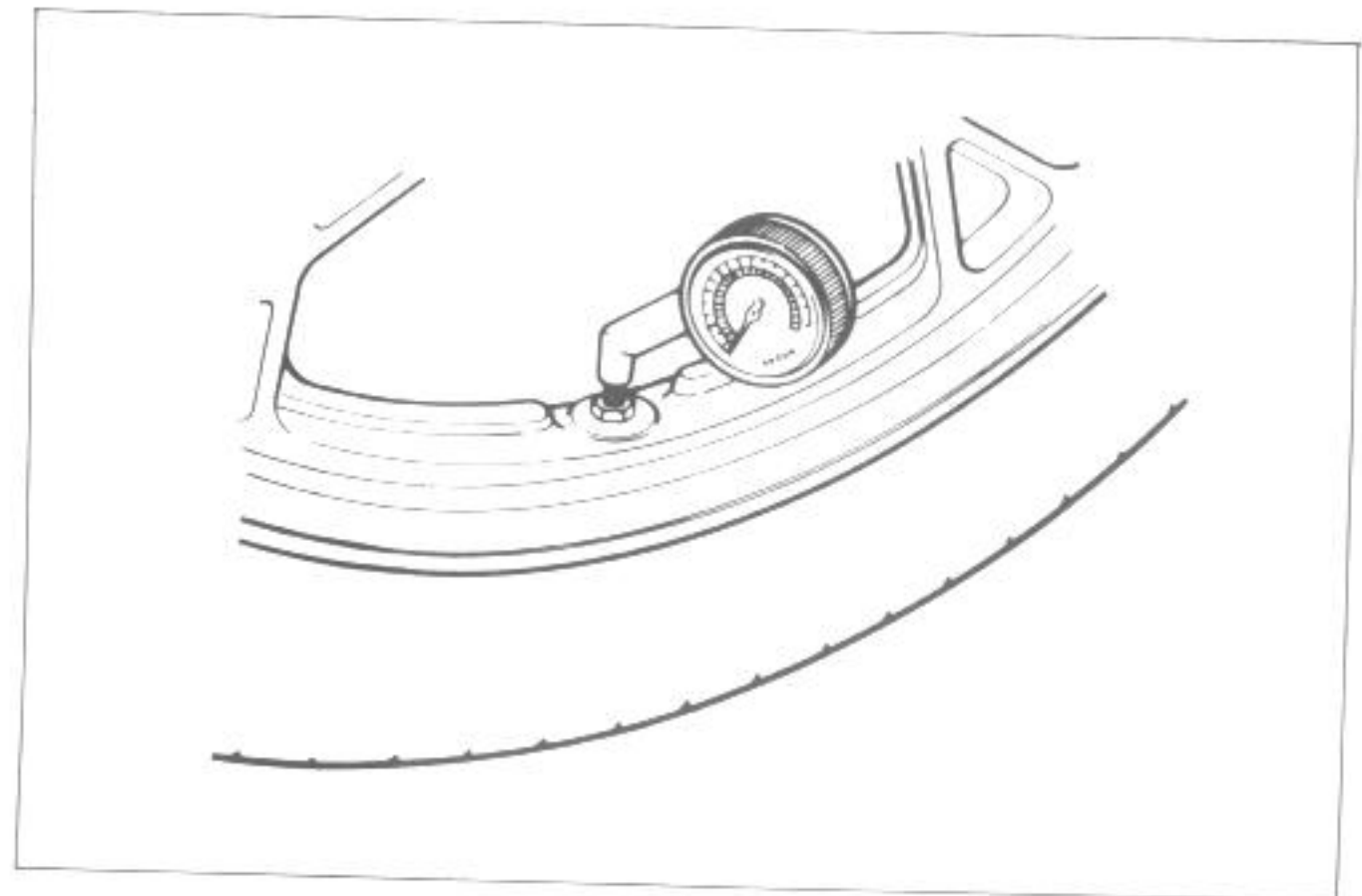
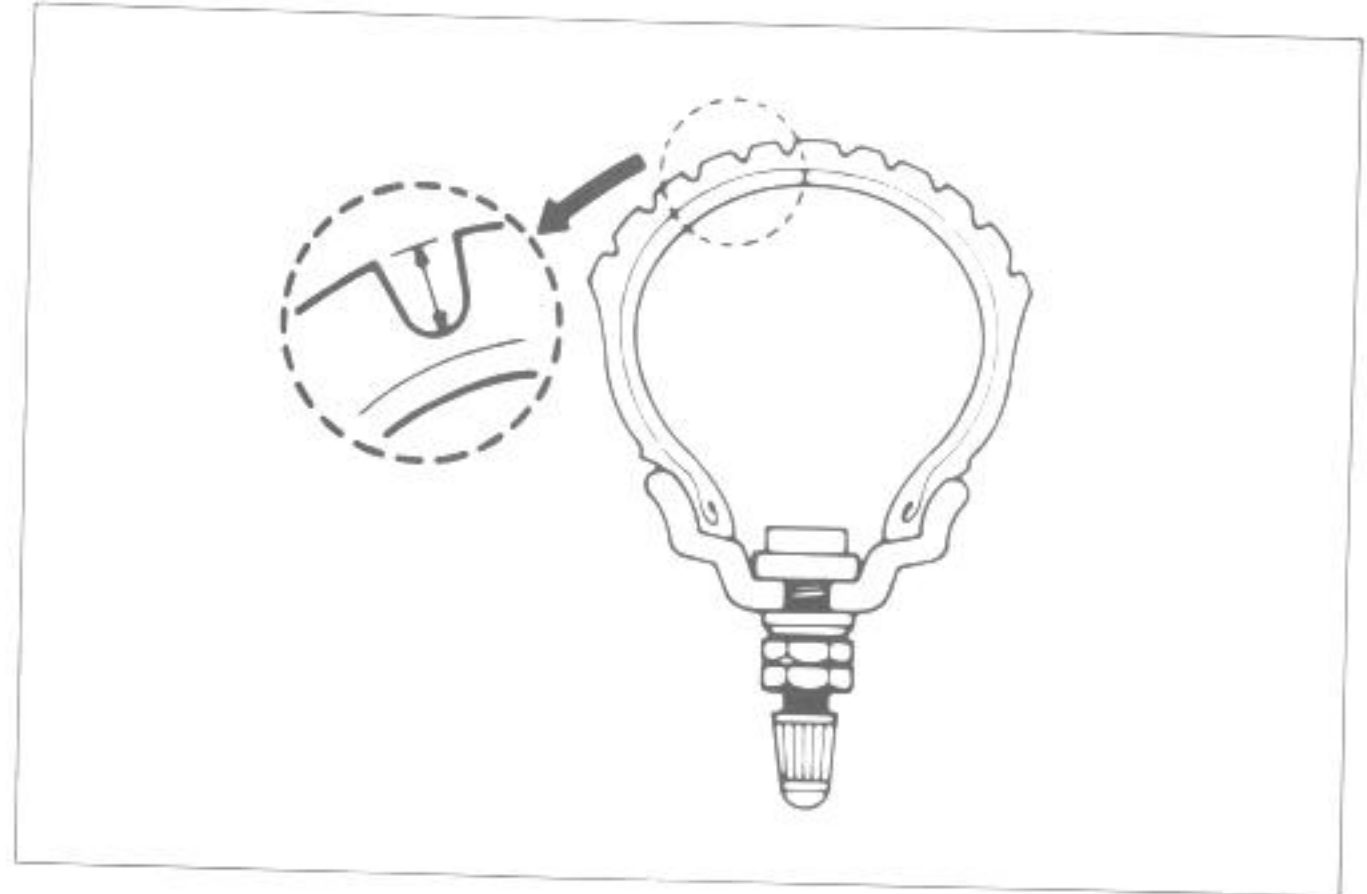

STEERING

Inspect Initial 1 000 km (600 mi) and Every 5 000 km (3 000 mi).

Taper roller type bearings are applied on the steering system for better handling.

Steering should be adjusted properly for smooth manipulation of handlebars and safe running. Too stiff steering prevents smooth manipulation of handlebars and too loose steering will cause poor stability.

Check that there is no play in the front fork assembly by supporting the machine so that the front wheel is off the ground, with wheel straight ahead, grasp lower fork tubes near the axle and pull forward. If play is found, perform steering bearing adjustment as described in page 6-28 of this manual.

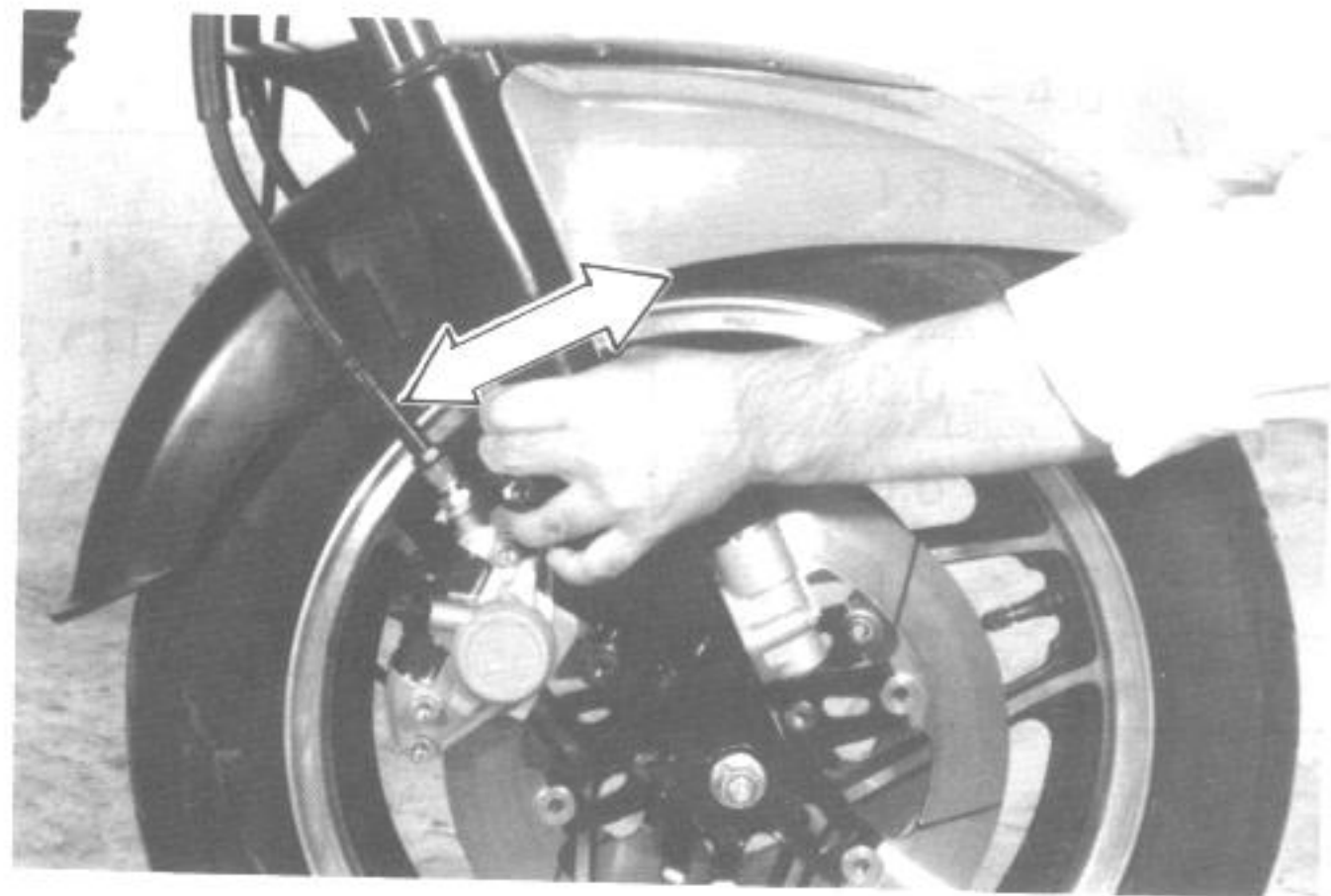

FRONT FORK

Inspect (oil change) Initial 1 000 km (600 mi) and Every 10 000 km (6 000 mi).

Inspect (air pressure) Every 5 000 km (3 000 mi) or 6 months. (For Canada)

- Inspect the front fork oil leakage, scoring and scratches on the outer surface of the inner tube and replace the defective parts if necessary. (See page 6-14).

99000-99044-15G

SUZUKI fork oil #15

- Fit the special tool to the air valve and adjust fork air pressure, to the following specified value. (See page 6-23) (For Canada)

Front fork air
pressure

30 kPa (0.3 kg/cm²)

09940-44120

Front fork air pressure
regulating gauge

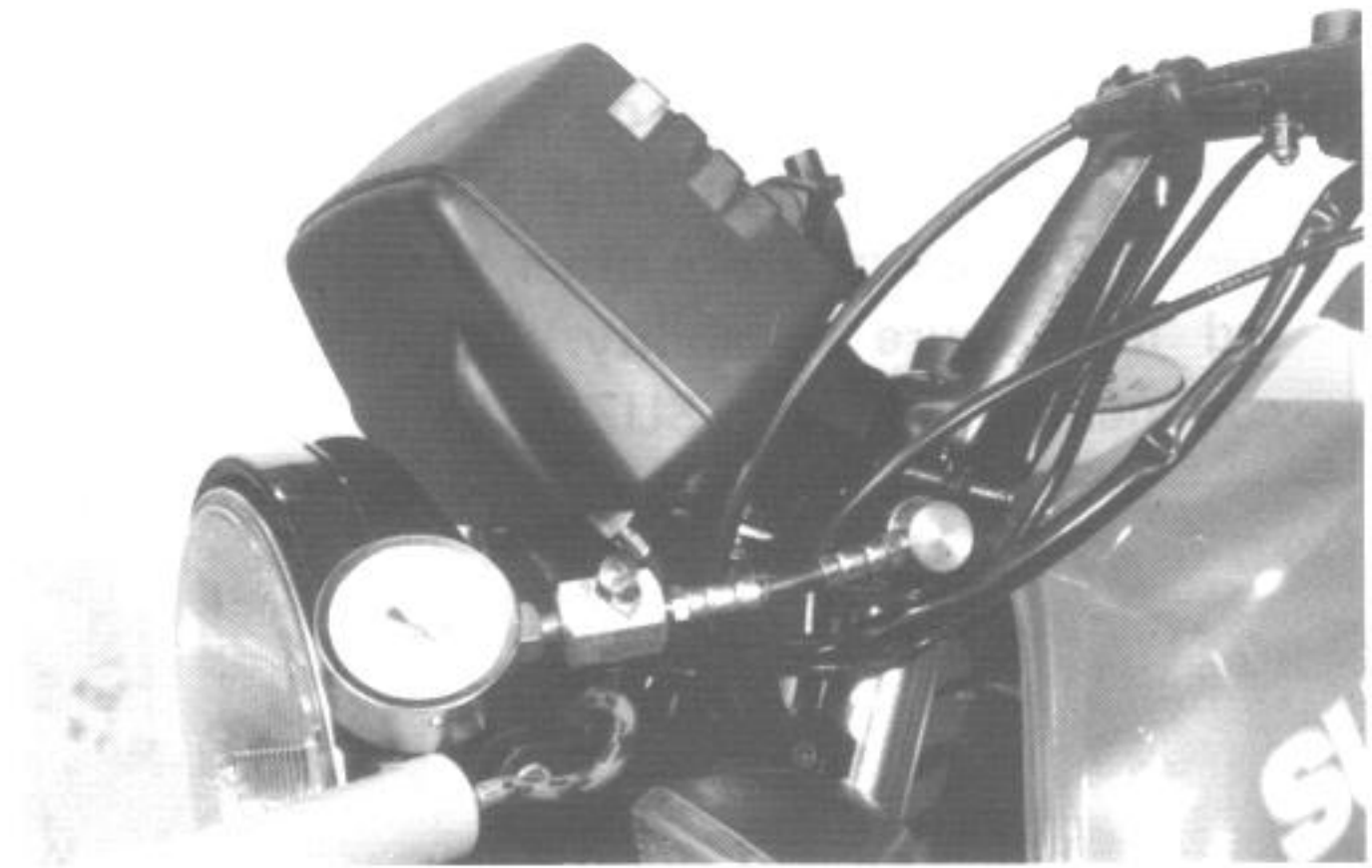

CHA

In
an

The
speci
on th

①

②

③

④

⑤

⑥

⑦

⑧

⑨

⑩

⑪

⑫

⑬

⑭

⑮

⑯

⑰

⑱

⑲

⑳

㉑

㉒

㉓

㉔

㉕

㉖

㉗

CHASSIS BOLTS AND NUTS

Inspect (Tighten) Initial 1 000 km (600 mi)
and Every 5 000 km (3 000 mi).

The nuts and bolts listed below are important safety parts. They must be retightened when necessary to the specified torque with a torque wrench. (Refer to page 2-25 for the locations of the following nuts and bolts on the motorcycle.)

Item	N·m	kg-m
① Steering stem head bolt	20 – 30	2.0 – 3.0
② Steering stem head clamp bolt	15 – 25	1.5 – 2.5
③ Front fork upper clamp bolt	20 – 30	2.0 – 3.0
④ Front fork lower clamp bolt	15 – 25	1.5 – 2.5
⑤ Front fork cap bolt	15 – 30	1.5 – 3.0
⑥ Front fork damper rod bolt	20 – 26	2.0 – 2.6
⑦ Front axle nut	36 – 52	3.6 – 5.2
⑧ Front axle holder nut	15 – 25	1.5 – 2.5
⑨ Handlebars set bolt	15 – 25	1.5 – 2.5
⑩ Handlebars holder bolt	50 – 60	5.0 – 6.0
⑪ Handlebars holder nut	20 – 30	2.0 – 3.0
⑫ Front master cylinder mounting bolt	5 – 8	0.5 – 0.8
⑬ Front caliper mounting bolt	25 – 40	2.5 – 4.0
⑭ Front caliper housing bolt	18 – 23	1.8 – 2.3
⑮ Brake hose union bolt	20 – 25	2.0 – 2.5
⑯ Air bleeder valve	6 – 9	0.6 – 0.9
⑰ Posi-damp unit bolt	6 – 8	0.6 – 0.8
⑱ Front and rear disc bolt	15 – 25	1.5 – 2.5
⑲ Swing arm pivot nut	50 – 80	5.0 – 8.0
⑳ Rear shock absorber fitting nut (Upper & Lower)	48 – 72	4.8 – 7.2
㉑ Rear cushion lever nut	84 – 100	8.4 – 10.0
㉒ Rear cushion rod-upper nut	84 – 100	8.4 – 10.0
㉓ Rear cushion rod-lower nut	84 – 100	8.4 – 10.0
㉔ Rear caliper mounting bolt	25 – 40	2.5 – 4.0
㉕ Rear caliper housing bolt	18 – 23	1.8 – 2.3
㉖ Rear torque link bolt and nut	10 – 15	1.0 – 1.5
㉗ Rear master cylinder mounting bolt	15 – 25	1.5 – 2.5

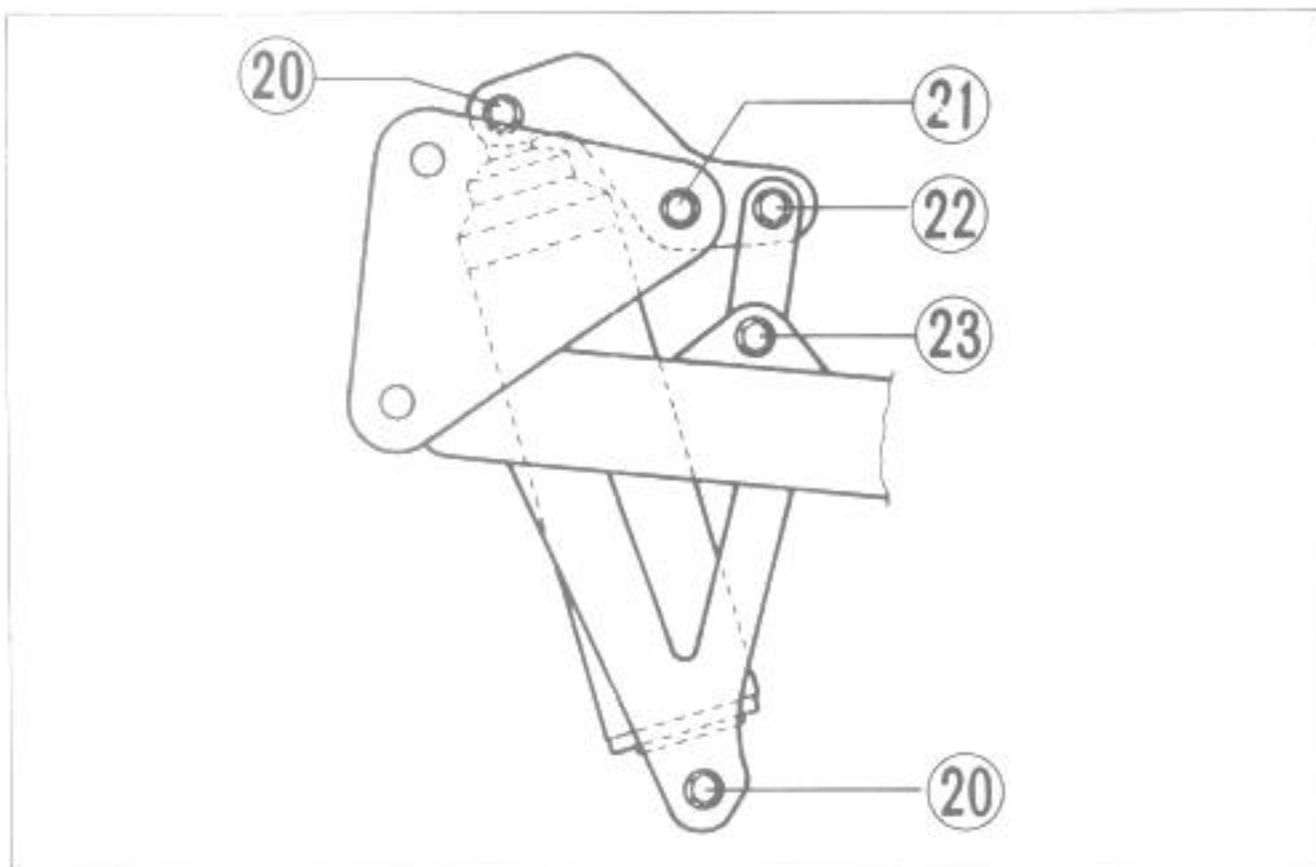
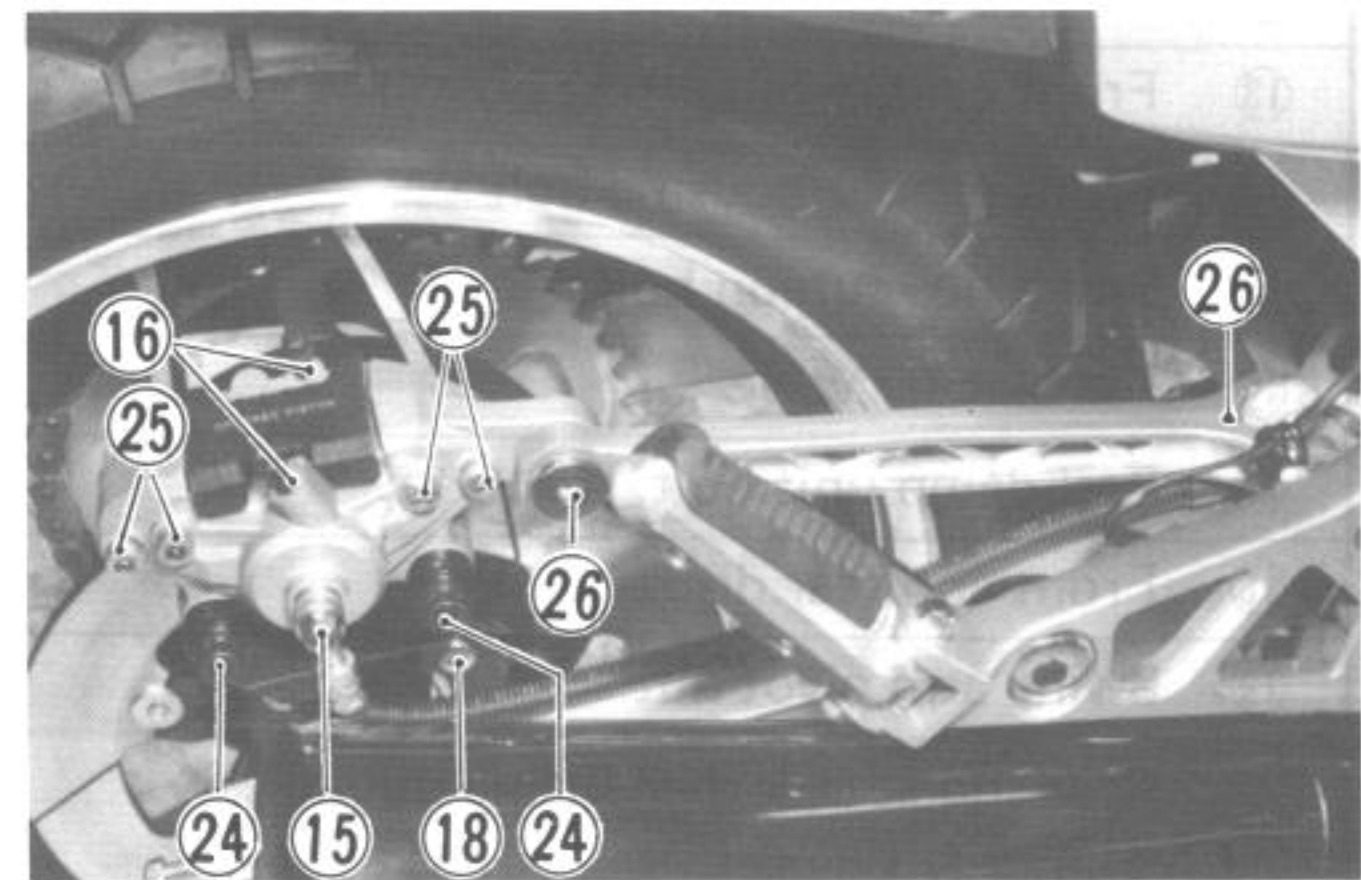
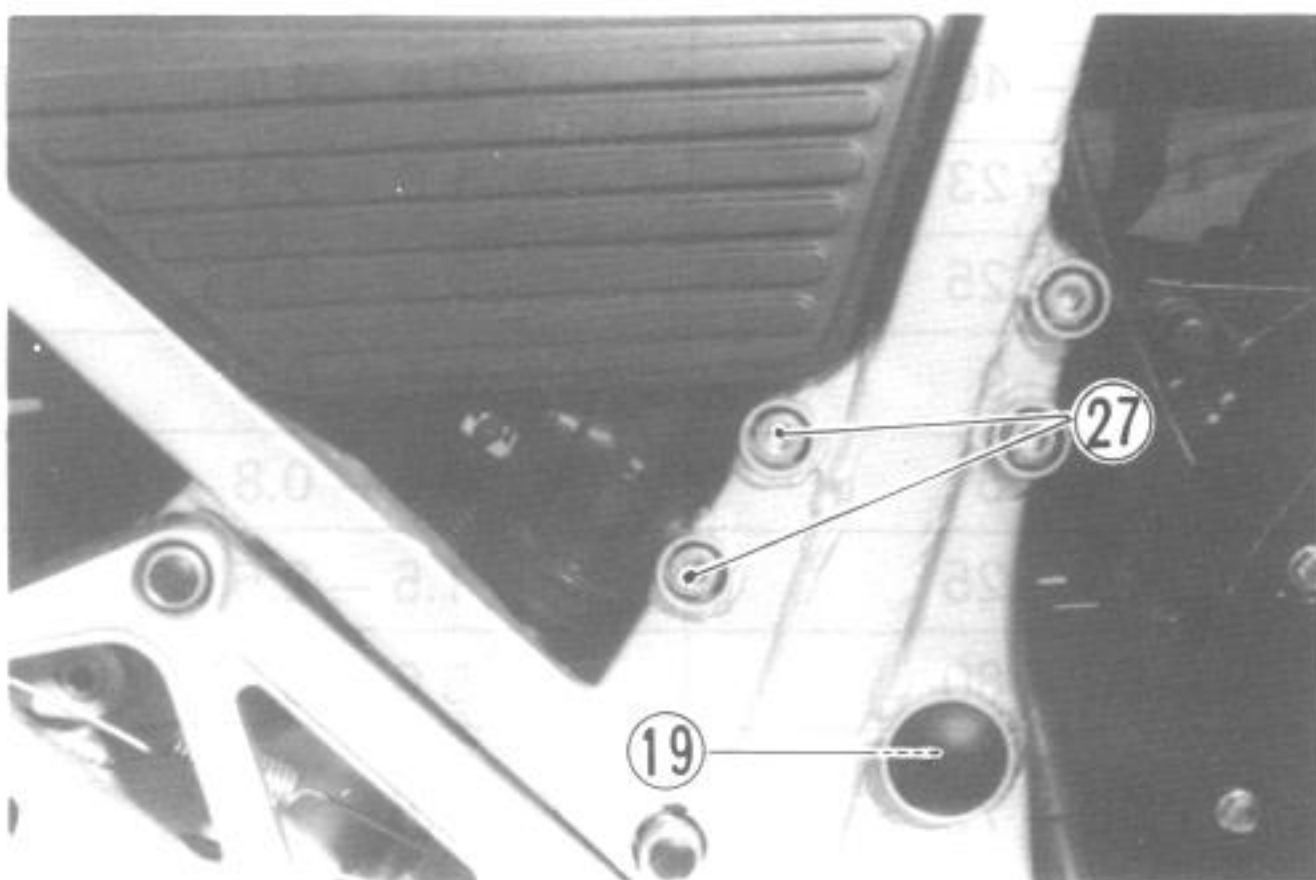
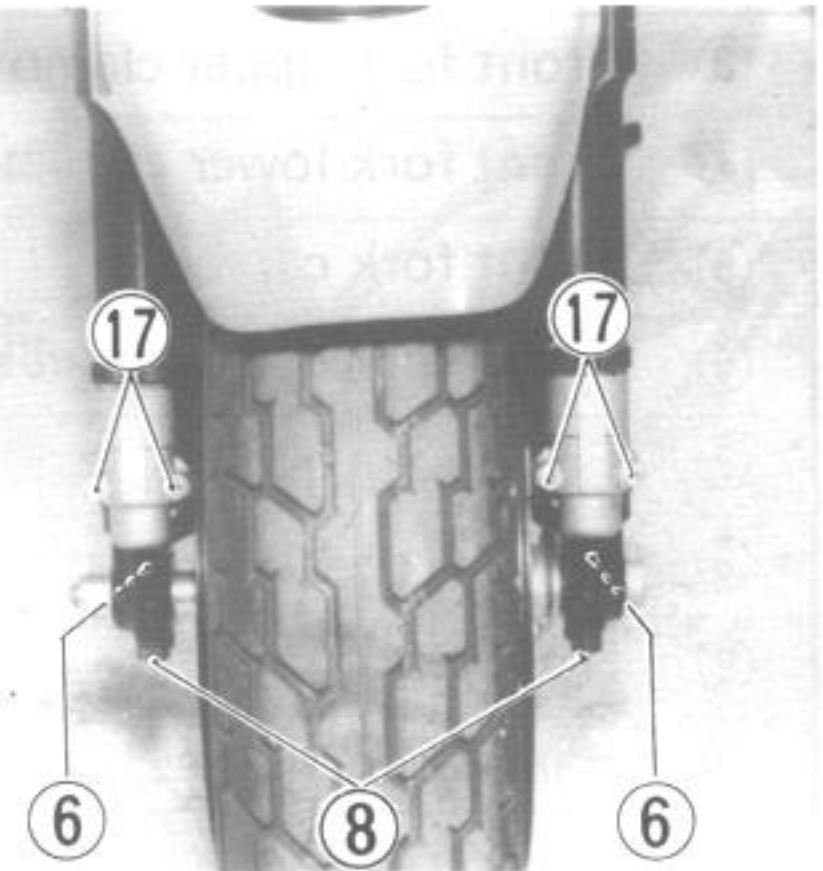
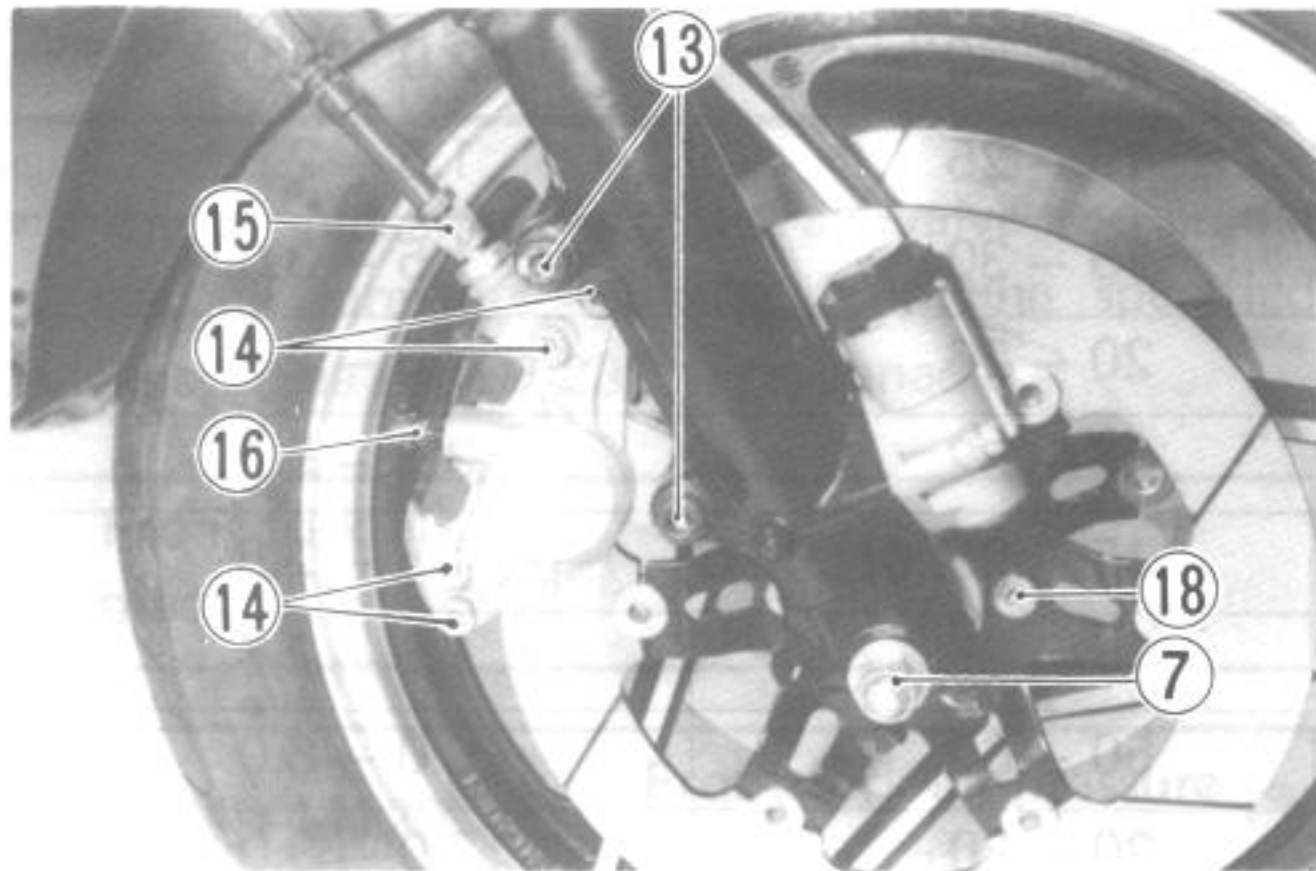
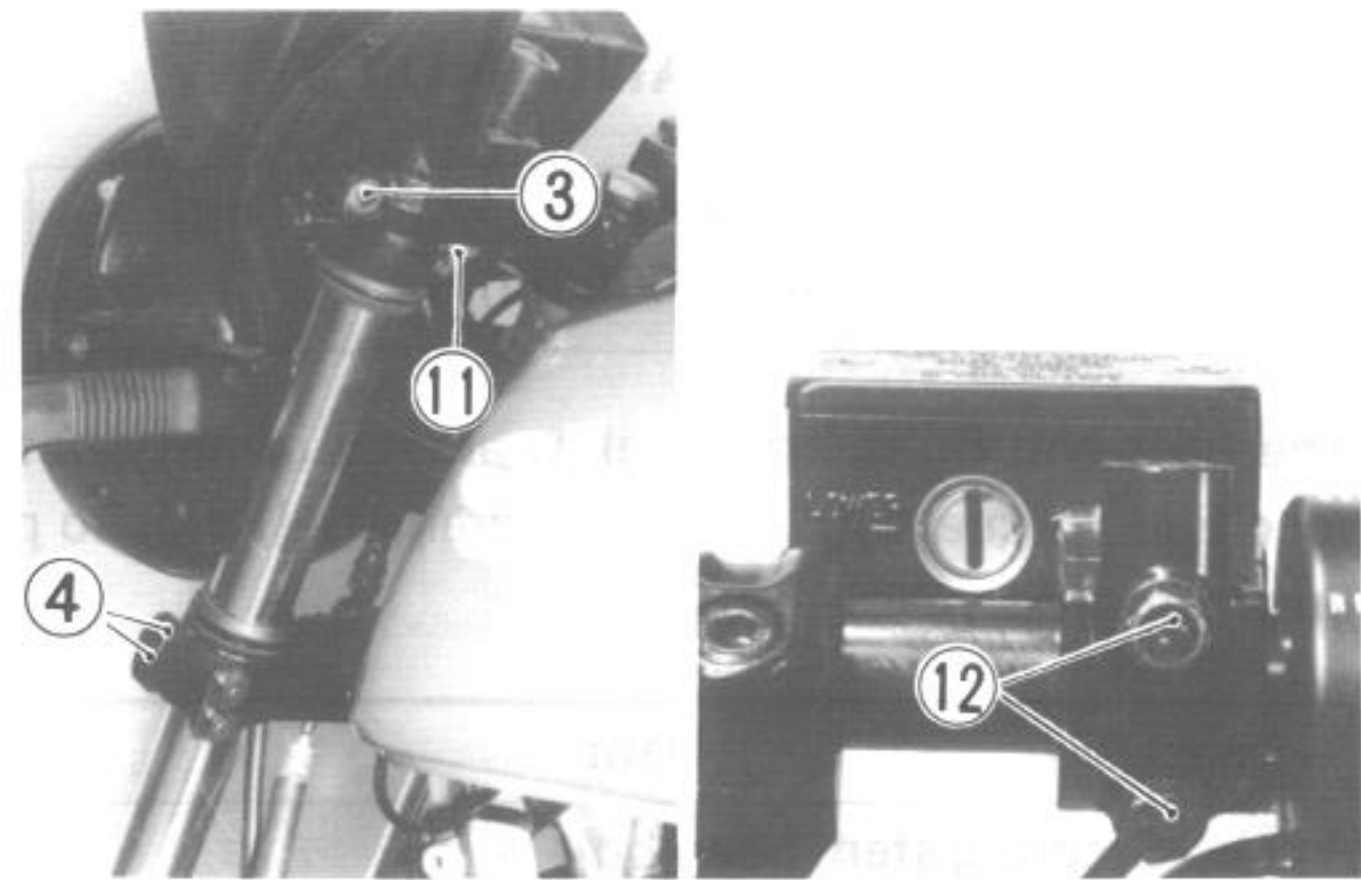
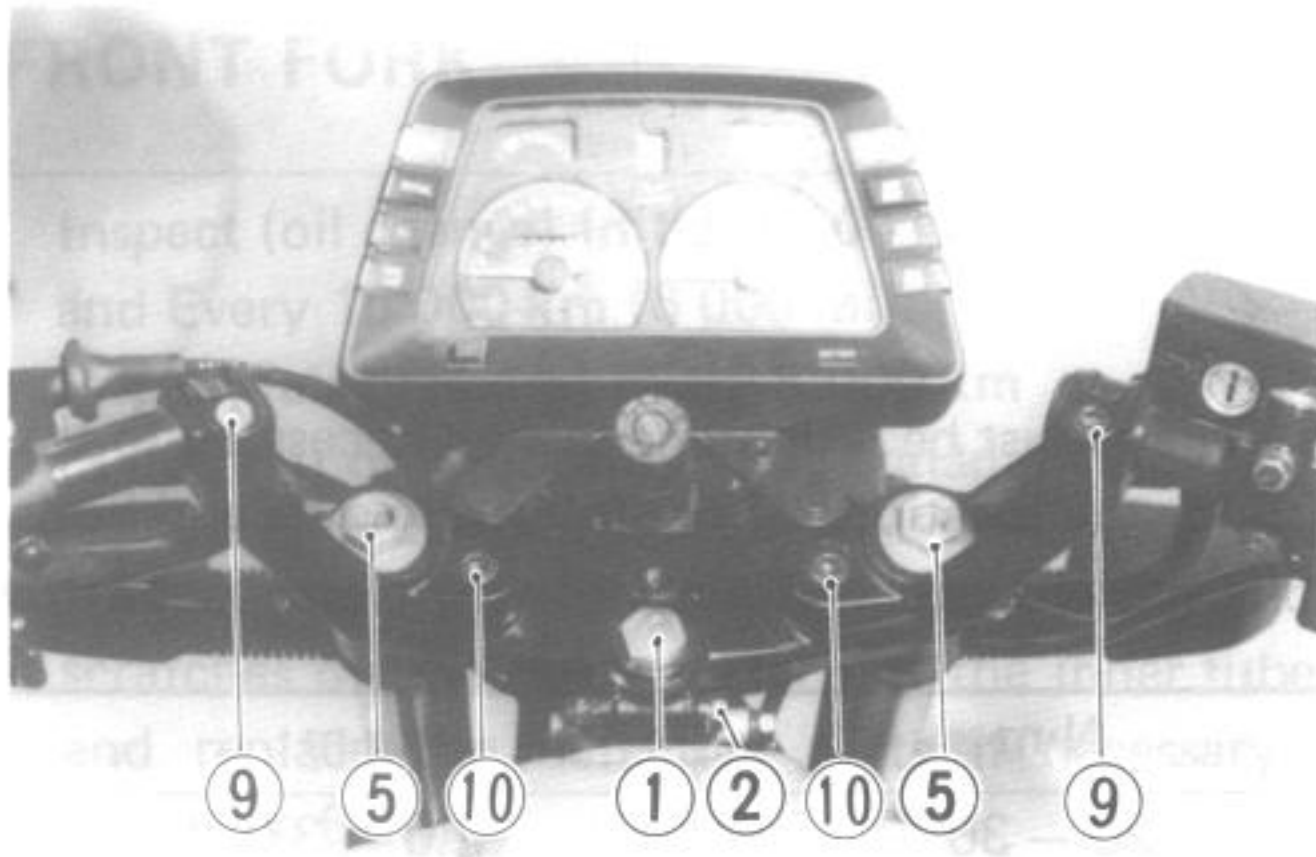

SERVICING ENGINE

CONTENTS

ENGINE COMPONENTS REMOVABLE WITH ENGINE IN PLACE	3- 1
ENGINE REMOVAL AND REINSTALLATION	3- 2
ENGINE DISASSEMBLY	3- 9
ENGINE COMPONENTS INSPECTION AND SERVICING	3-20
CYLINDER HEAD SERVICING	3-20
VALVE	3-21
VALVE SEAT	3-24
VALVE SPRING	3-26
CAMSHAFT	3-29
CAM CHAIN TENSIONER	3-32
CAM CHAIN	3-35
CYLINDER	3-35
PISTON	3-36
PISTON RING	3-37
CONNECTING ROD	3-39
CRANKSHAFT	3-39
CLUTCH	3-40
STARTER CLUTCH	3-42
OIL PUMP	3-43
TRANSMISSION GEAR	3-44
SHIFT FORK	3-45
ENGINE REASSEMBLY	3-48

ENGINE COMPONENTS REMOVABLE WITH ENGINE IN PLACE

Parts to be removably mounted without dismantling engine and their operations. The following sections describe operational contents from top end to air cleaner, following the previous sections dealing with engine removal. Parts which can be removably mounted without dismantling the engine are described here. See reference pages with respect to their operations.

ENGINE LEFT SIDE

	See page
Gear shift lever	3-4
Engine sprocket cover	3-4
Engine sprocket and drive chain	3-4
Generator cover	3-15
Generator rotor	3-15
Starter clutch	3-15
Starter clutch idle gear	3-15
Gear position indicator light switch body	3-18
Generator stator	3-42

ENGINE CENTER

	See page
Air cleaner	2-3
Oil filter	2-14
Exhaust and muffler	3-3
Clutch cable	3-3
Carburetor	3-3
Throttle and starter cables	3-3
Cam chain tensioner	3-9
Cylinder head cover	3-9
Camshaft	3-9
Cylinder head	3-10
Cylinder	3-10
Piston	3-11
Oil pressure and oil temperature switches	3-11
Starter motor	3-12
Oil pan	3-16
Sump filter	3-16

- Generator cover and starter motor lead wire should be removed from the starting motor relay side.

ENGINE RIGHT SIDE

	See page
Signal generator	3-12
Clutch cover	3-12
Clutch release bearing	3-13
Clutch pressure, drive and driven plates	3-13
Oil pump drive gear	3-13
Primary driven gear	3-13
Oil pump ass'y	3-14
Gear shifting shaft	3-14
Gear shifting pawl and cam drive gear	3-18



ENGINE
ENGINE
 Before the engine oil. The procedure explained in the installation procedure.

- Place by re
- Remo
- Disco and n from
- Disco move
- Disco take c
- Disco remov
- Take caps.
- Disco from

ENGINE REMOVAL AND REINSTALLATION

ENGINE REMOVAL

Before taking the engine out of the frame, wash the engine with a steam cleaner and drain engine oil.

The procedure of engine removal is sequentially explained in the following steps, and engine installation is effected by reversing the removal procedure.

- Place an oil pan under the engine and drain oil by removing oil drain plug ① and filler cap.
- Remove the seat and frame covers.
- Disconnect the solution level switch lead wire and remove the battery \ominus and \oplus lead wires from the battery terminals.
- Disconnect the fuel gauge lead wires and remove the two bolts ②.
- Disconnect the fuel hose and vacuum hose and take off the fuel tank.
- Disconnect the ignition coil lead wires and remove the ignition coil fitting nuts.
- Take off the ignition coils with spark plug caps.
- Disconnect the blow-by gas breather pipe ③ from the cylinder head cover cap.

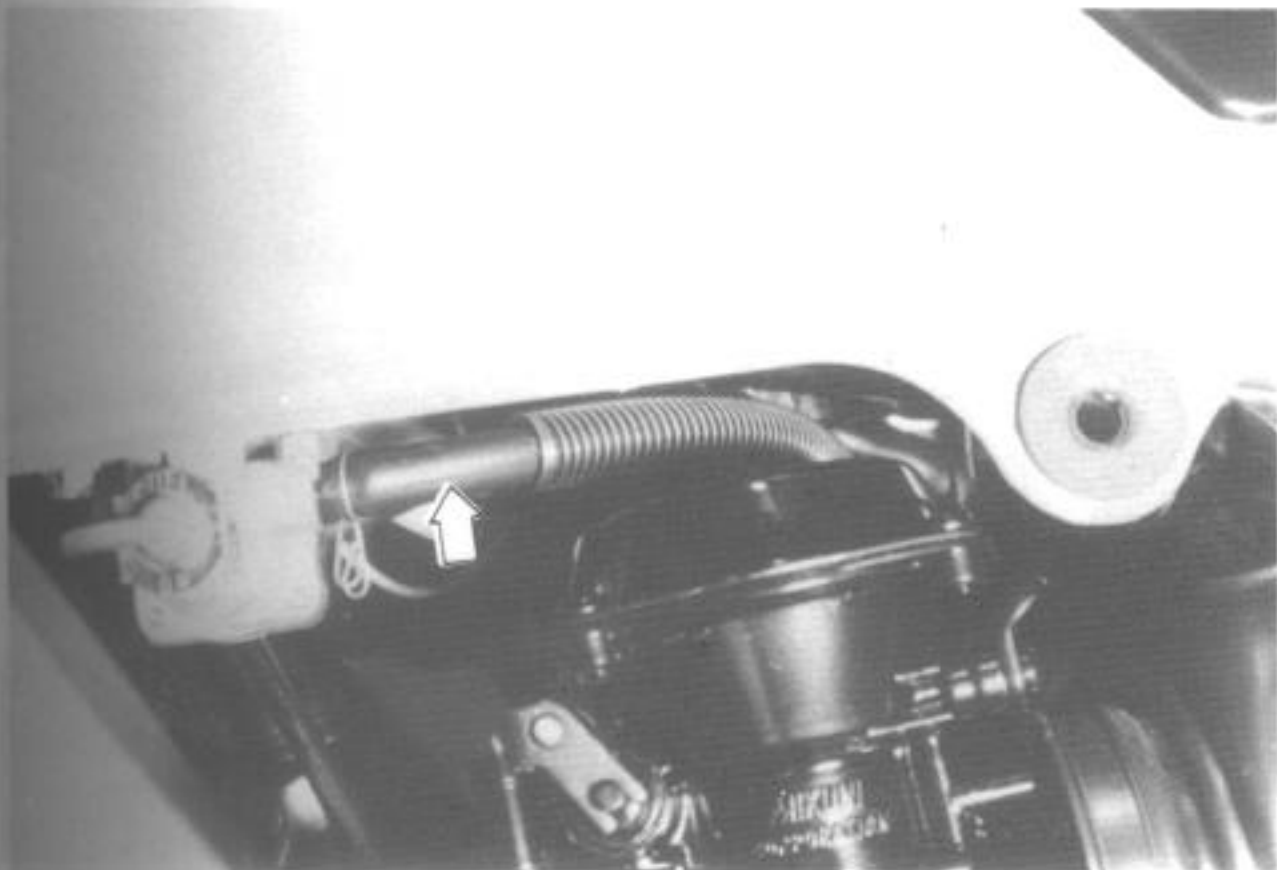
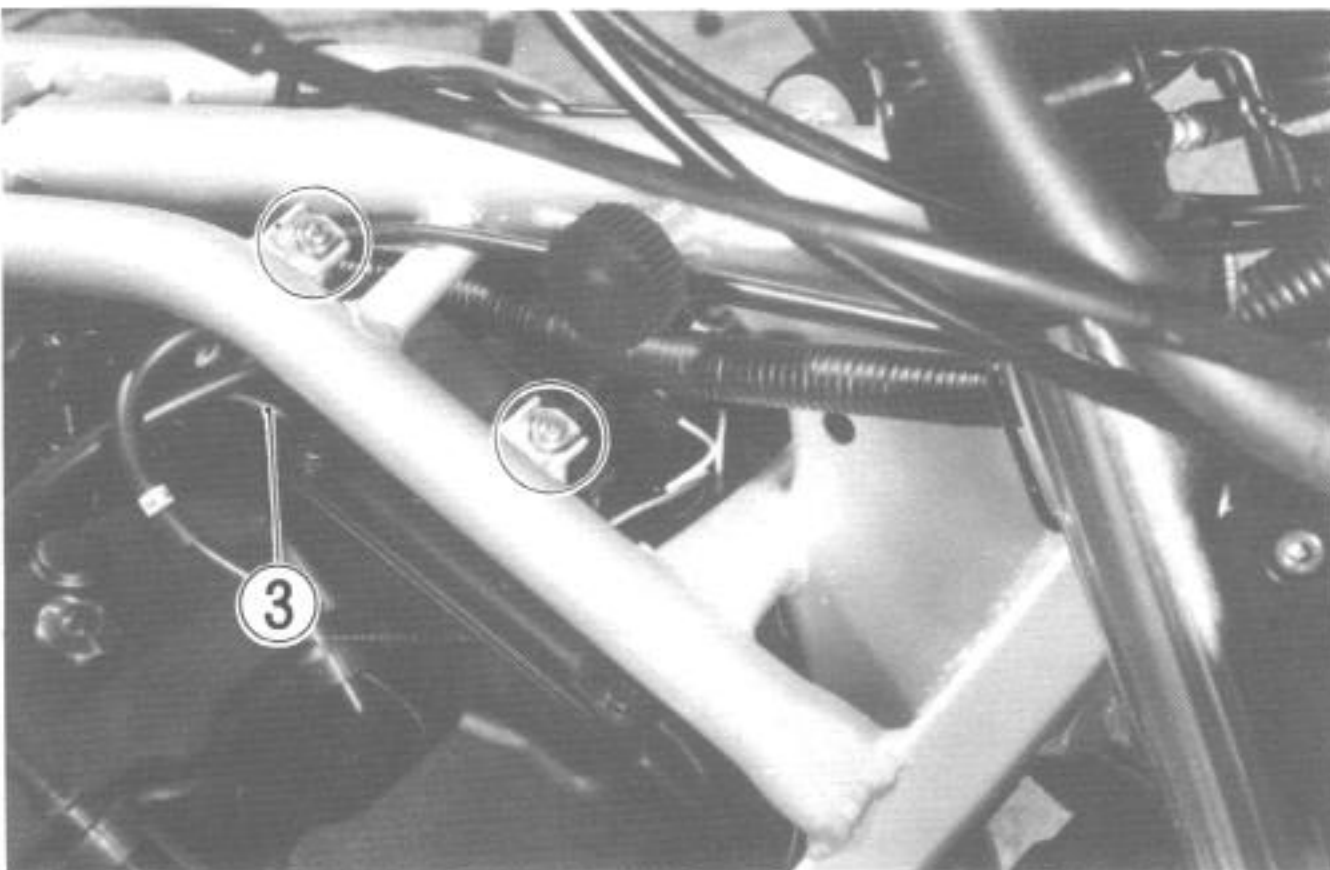
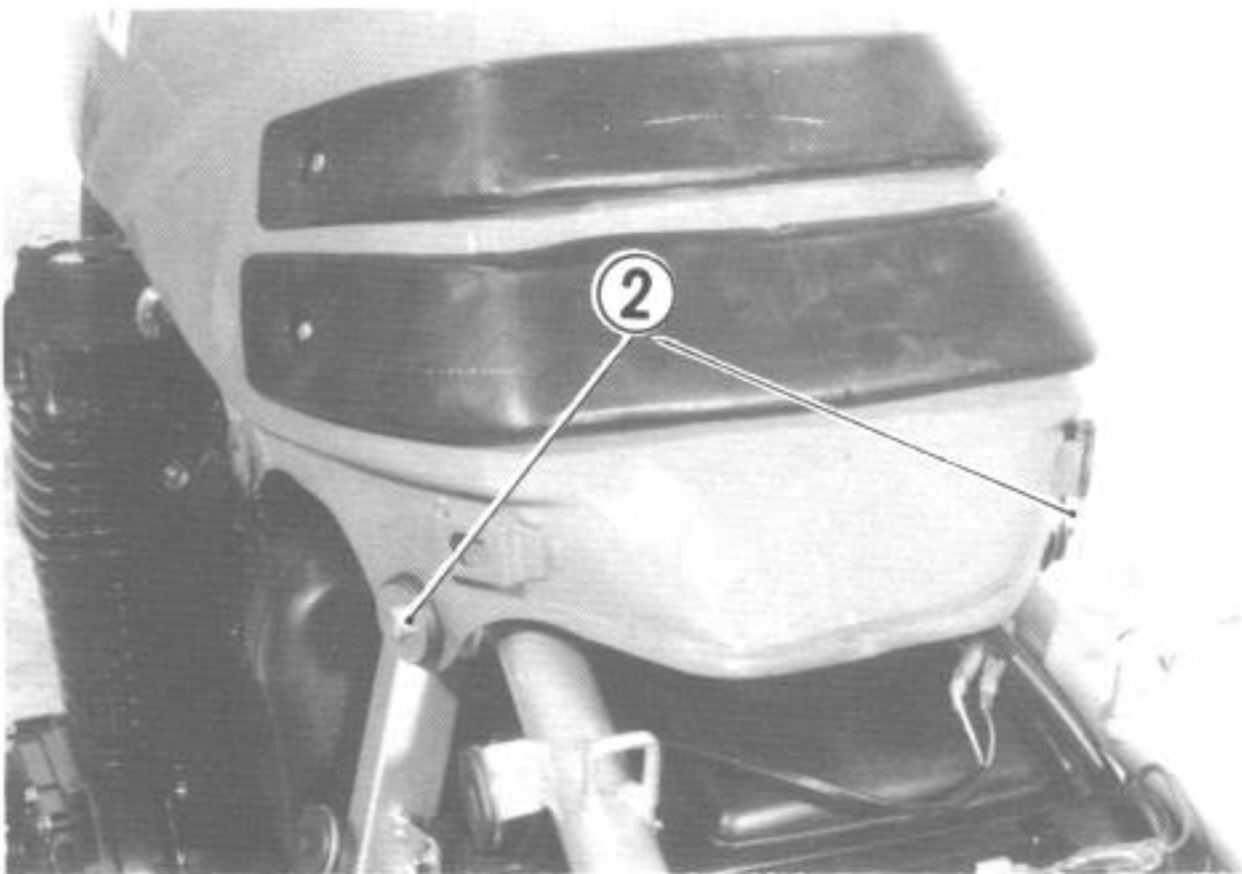
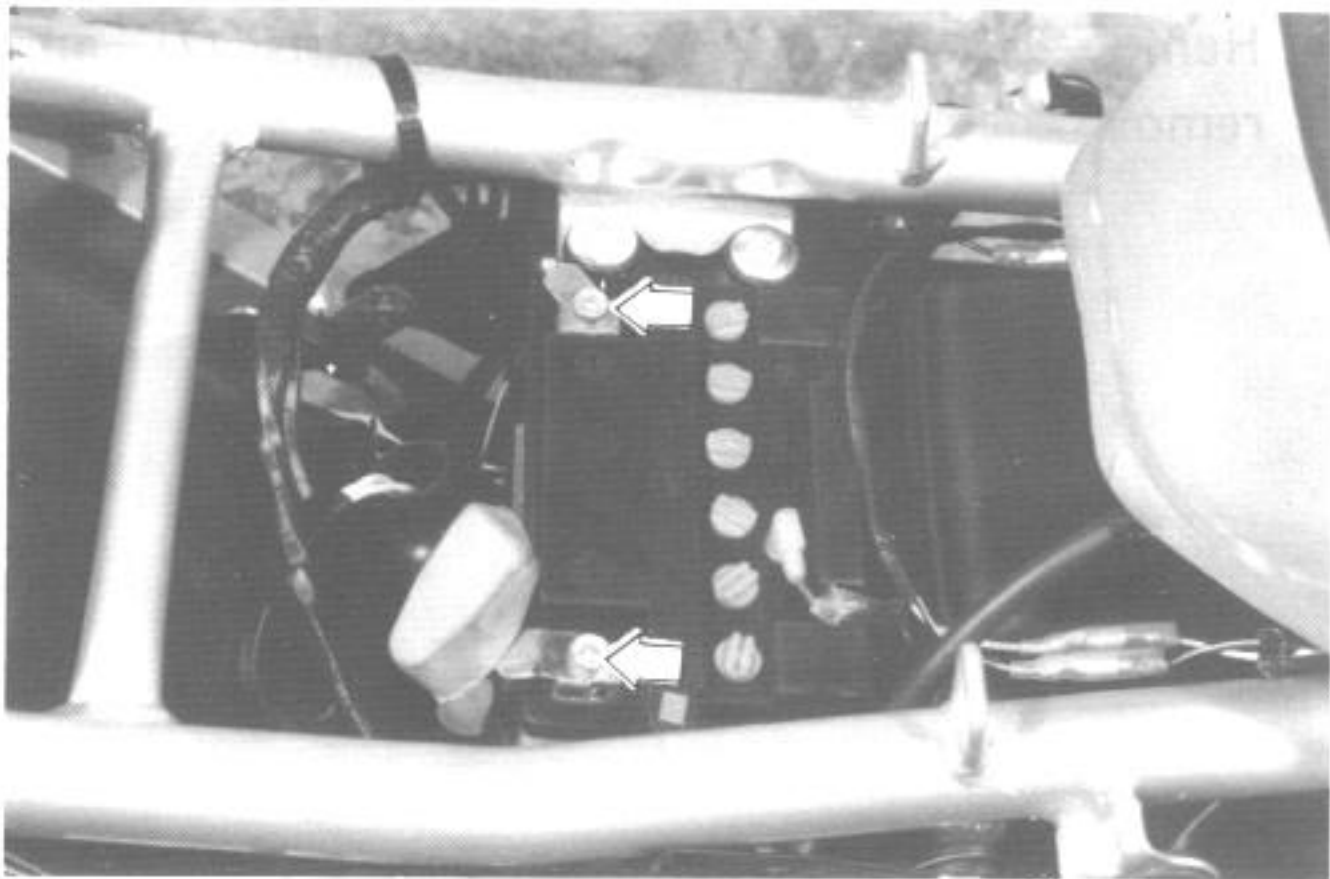
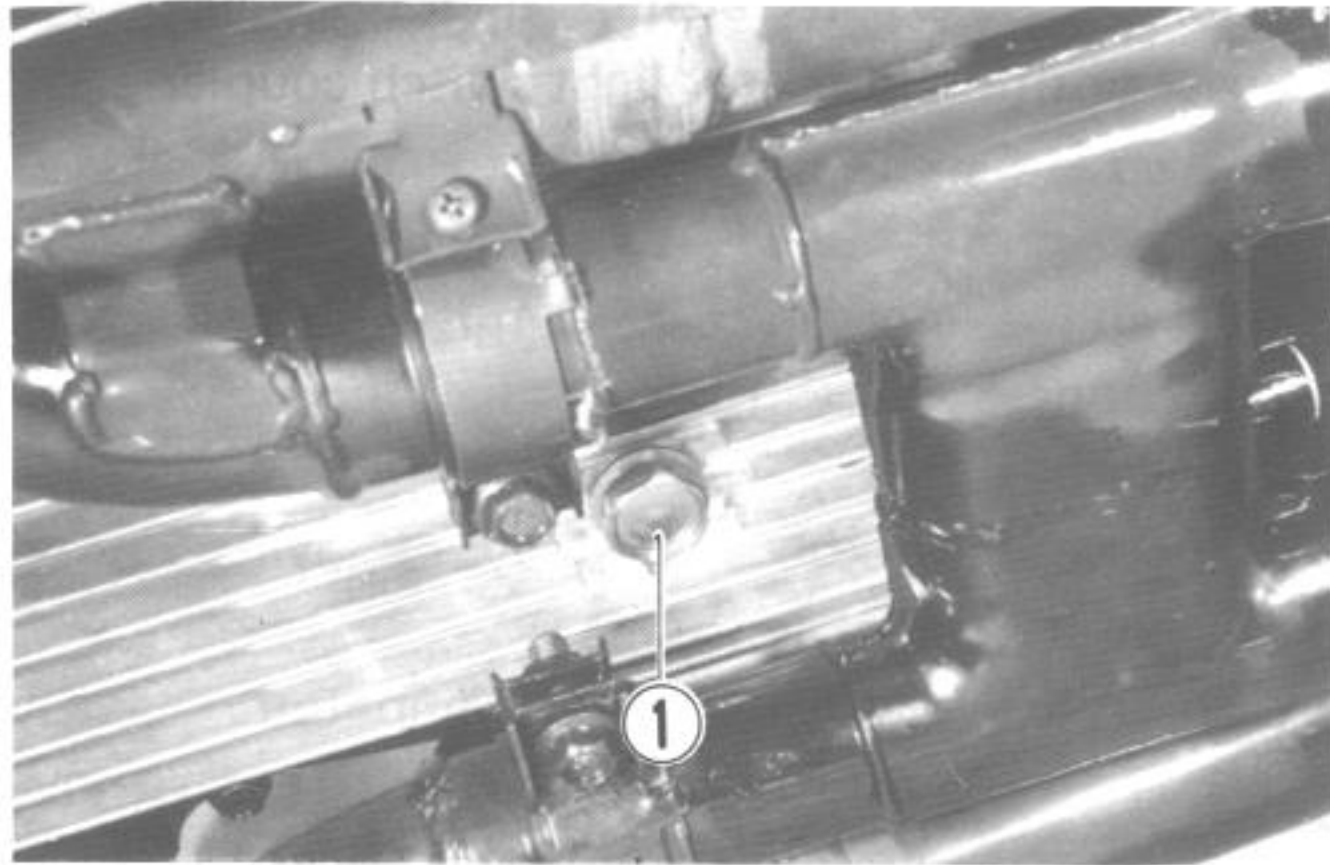

- Remove the two clamps and disconnect the gear position indicator light switch coupler.
- Remove the two screws ①.
- Loosen eight screws ② for carburetor mounting, and take off the carburetor.
- Disconnect the throttle and starter cables from the carburetor.
- Remove the clutch cable by removing release arm bolt ③ and adjuster ④.
- Remove the exhaust pipe clamp bolts ⑤ by using the 8 mm hexagon wrench, and remove No. 2 and No. 3 exhaust pipe after removing two securing bolts ⑥.
- Remove the muffler mounting nuts ⑦, and remove the right and left mufflers.

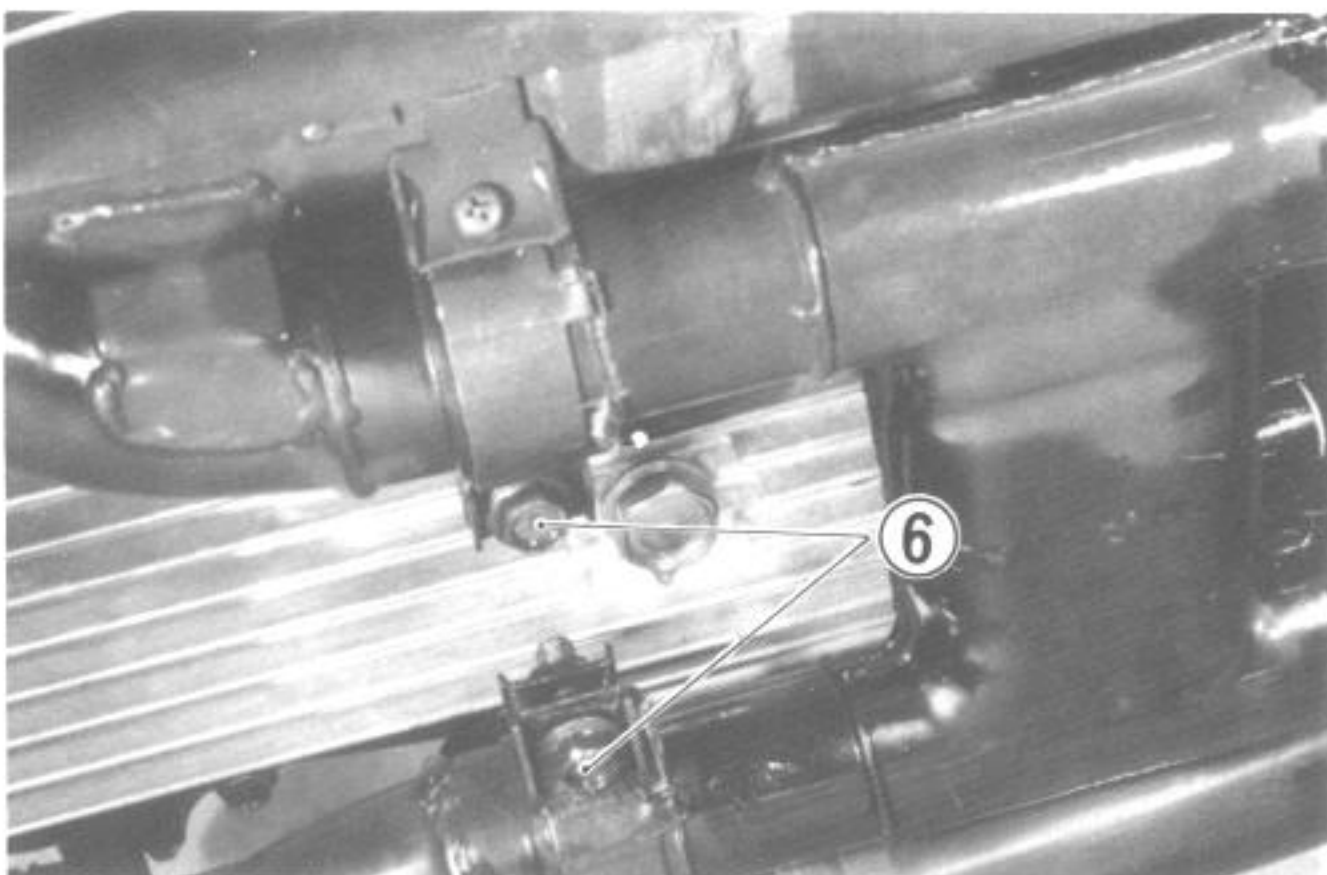
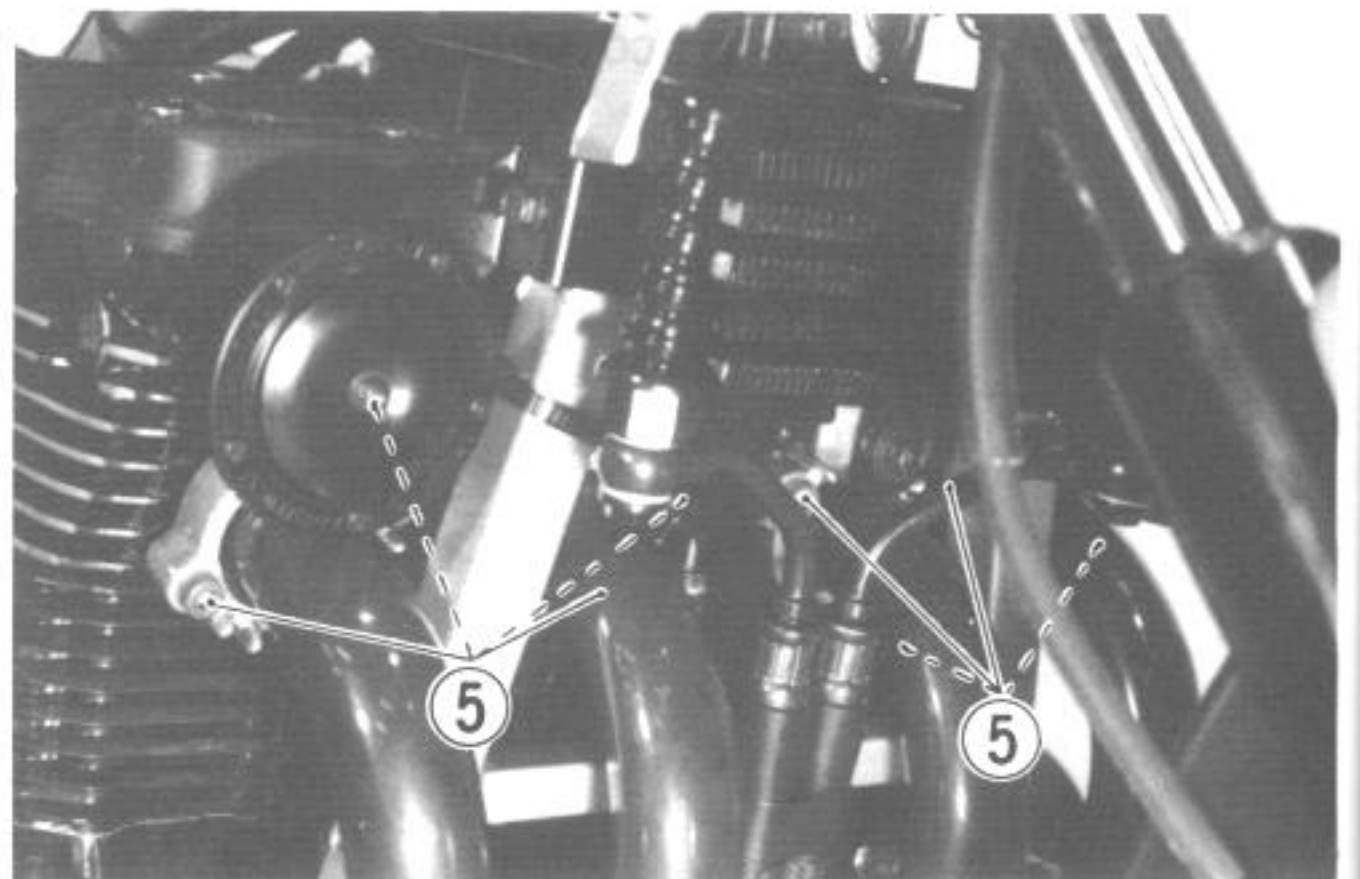
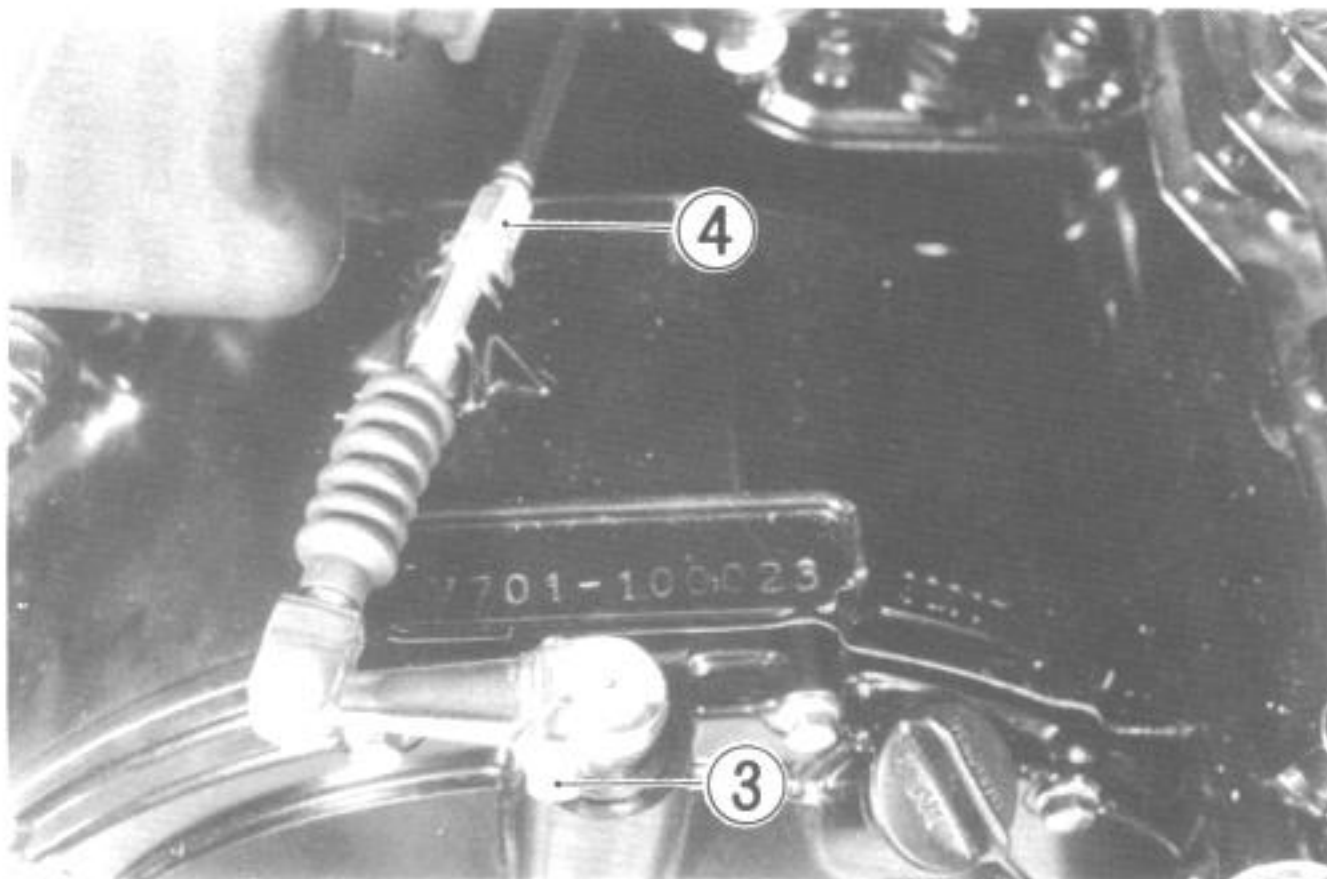
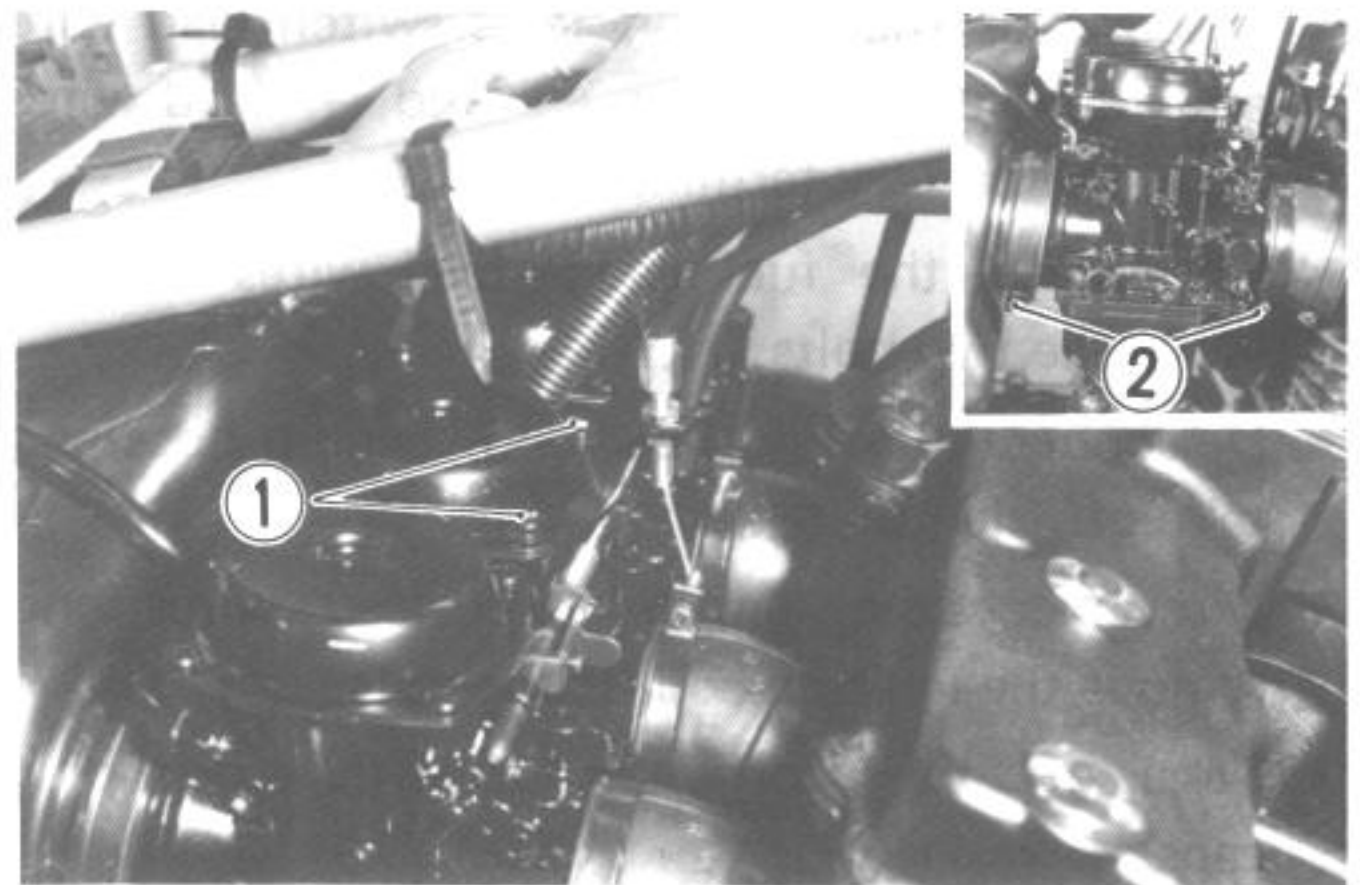
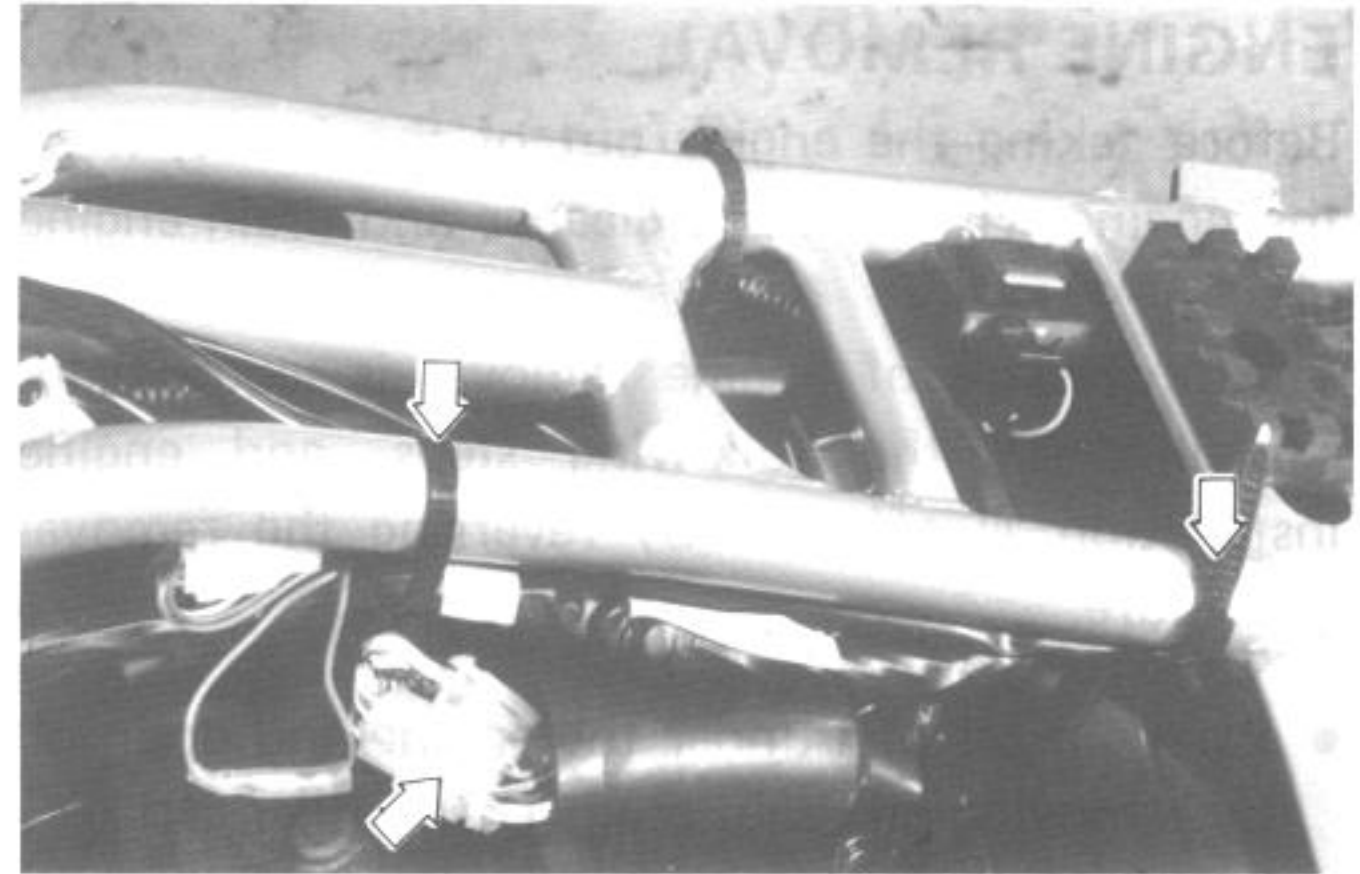

- Dis...
- ger...
- lea...
- ④
- Re...
- sh...
- Re...
- Fla...
- mo...
- sing...
- Re...
- Los...
- The...
- out...
- Pus...
- driv...

- Disconnect the generator lead wires ①, signal generator lead wires ②, oil pressure switch lead wire ③, oil temperature switch lead wire ④ and starter motor lead wire ⑤.
- Remove the side stand switch ⑥ and gear-shift lever ⑦.
- Remove the engine sprocket cover ⑧.
- Flatten the engine sprocket lock washer, and remove the engine sprocket nut ⑨ while depressing the rear brake pedal.
- Remove the axle caps ⑩.
- Loosen the lock nuts ⑪ and adjuster bolts ⑫. Then loosen the rear axle nut ⑬ after pulling out the cotter pin ⑭.
- Push the rear wheel forward, and take off the drive chain with the engine sprocket.

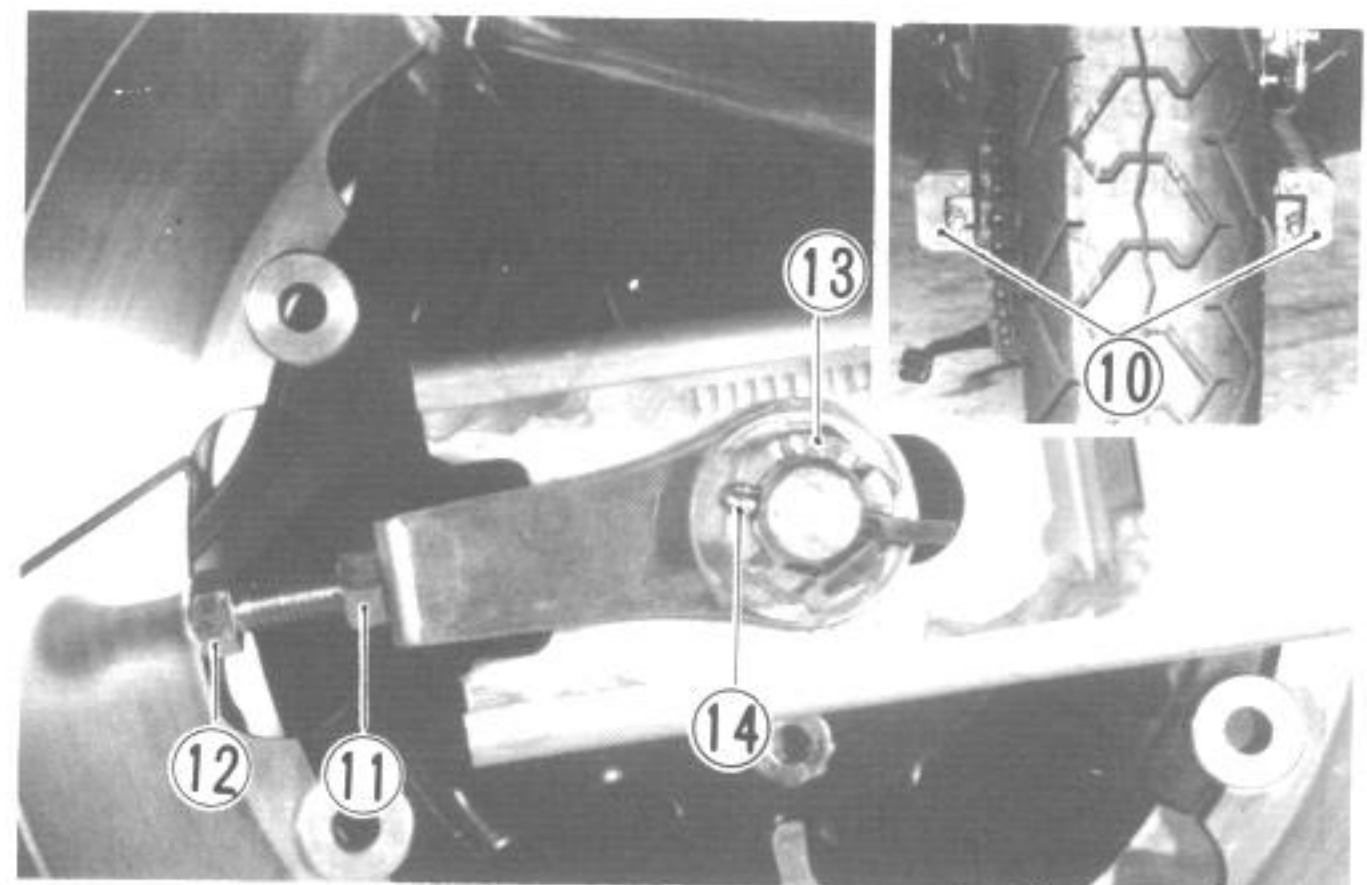
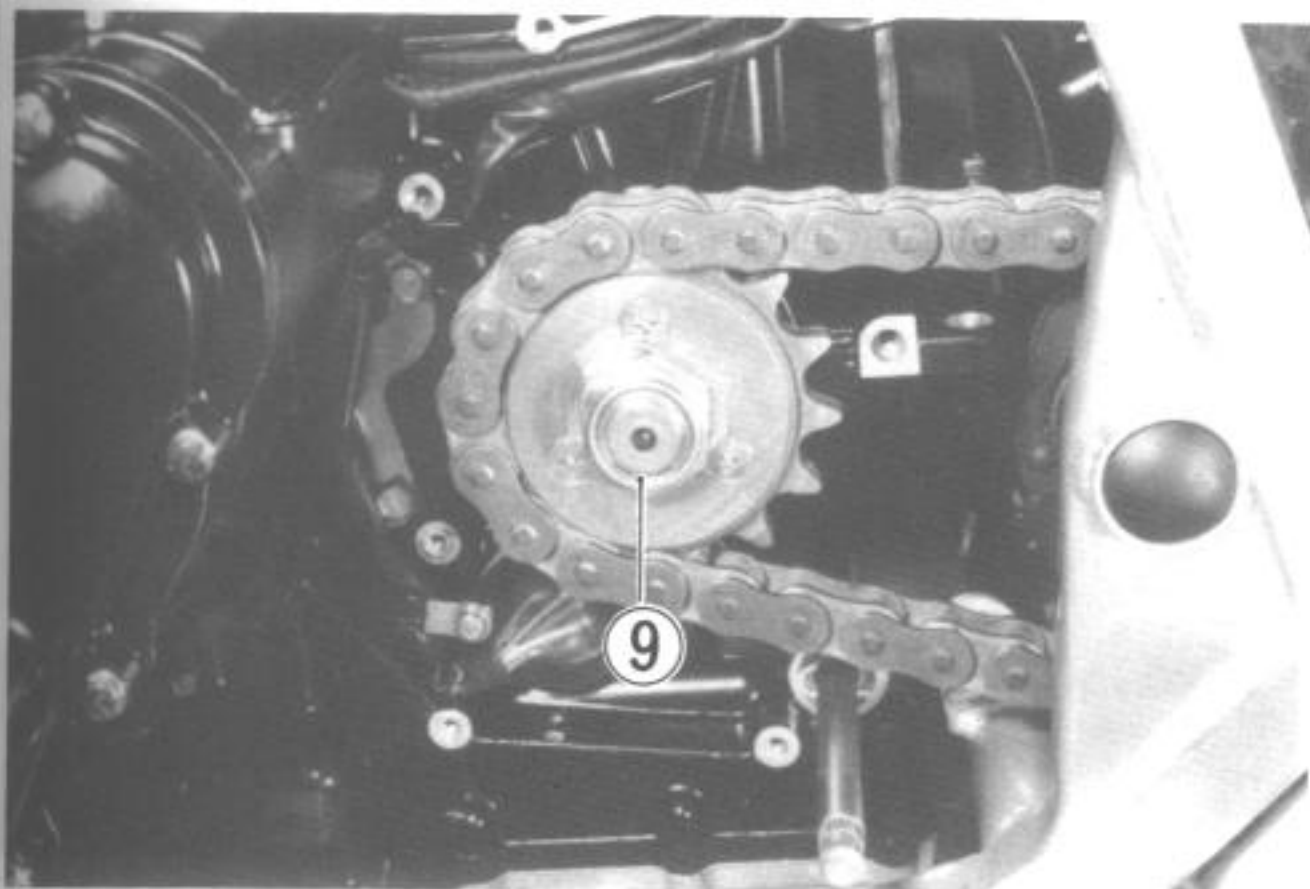
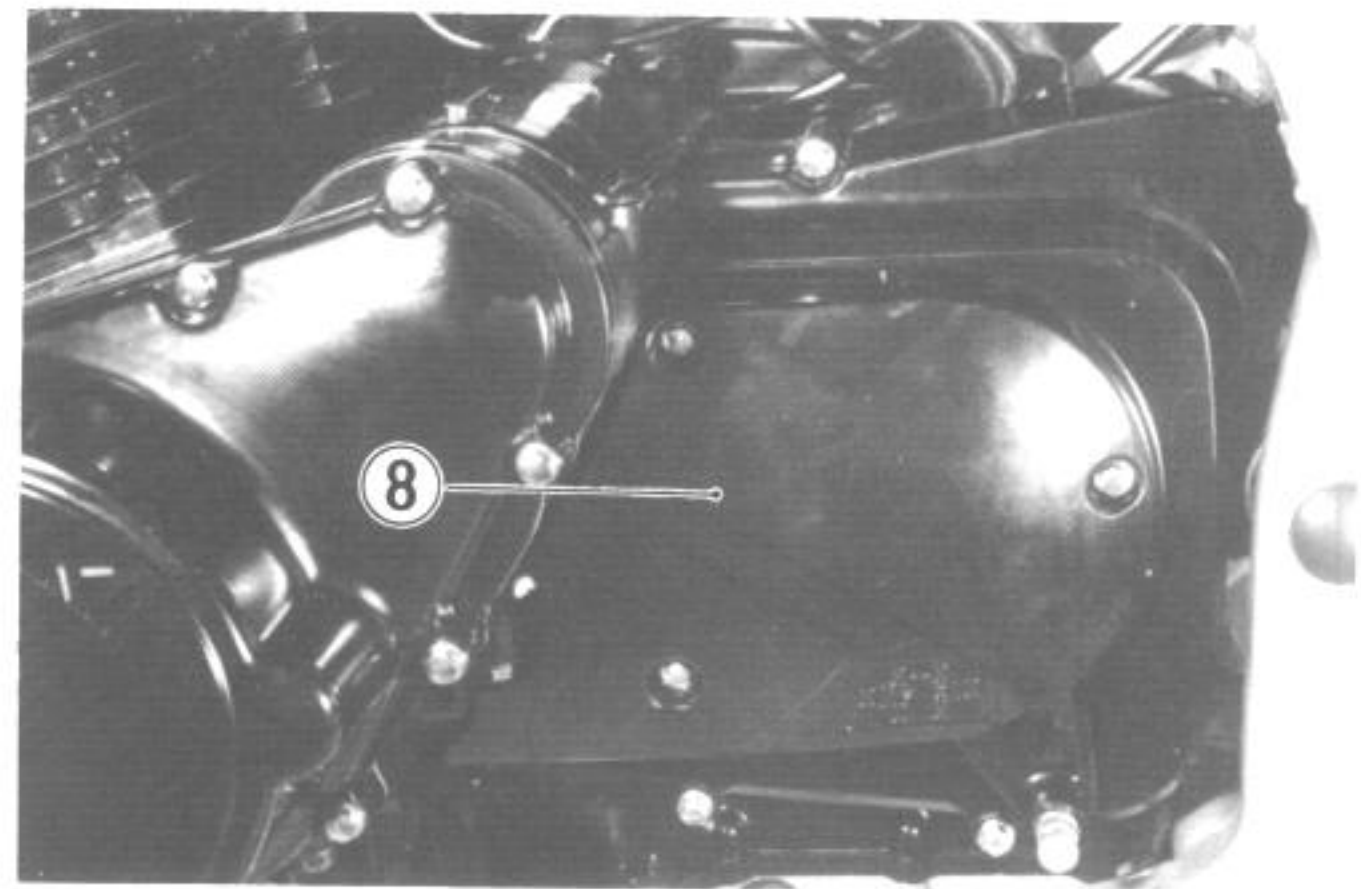
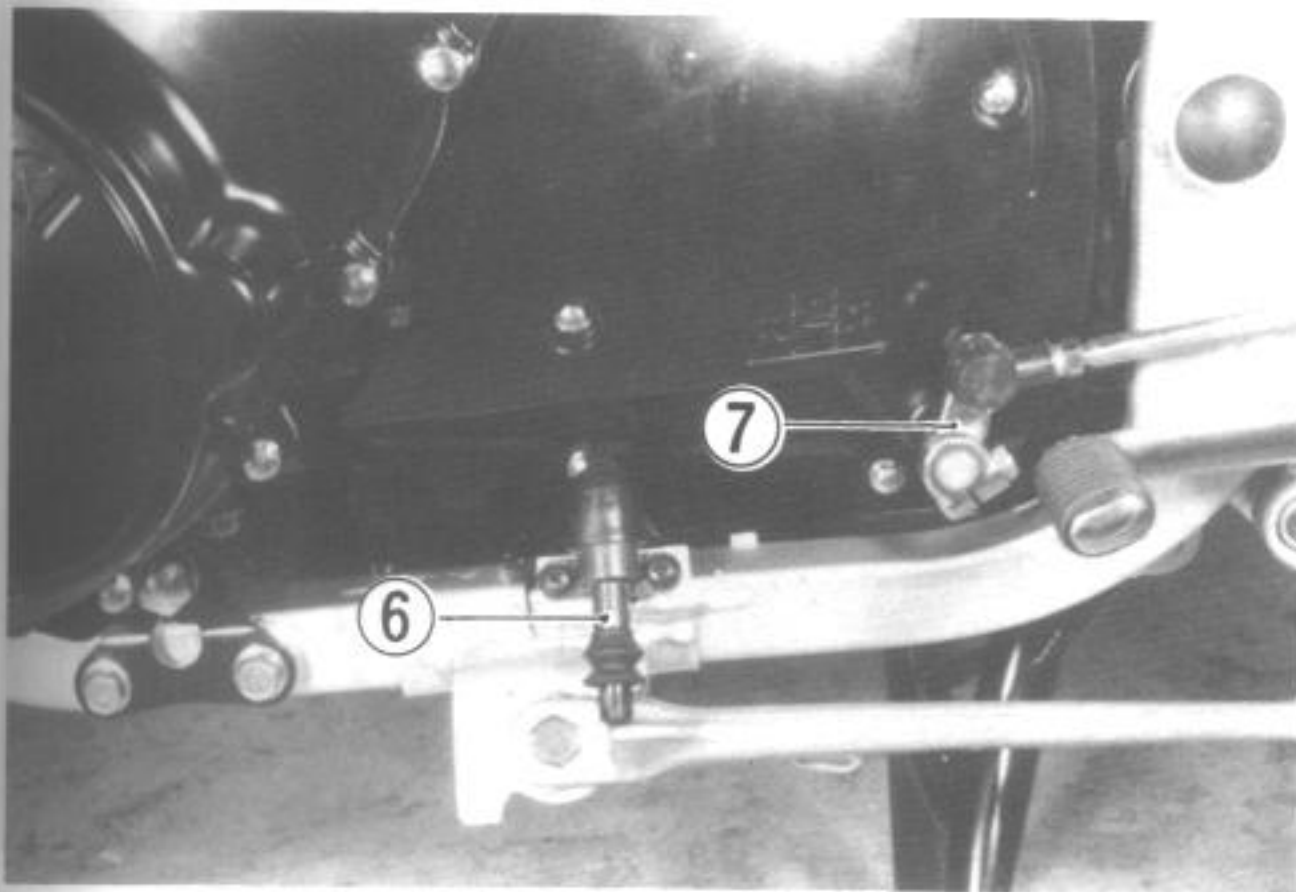
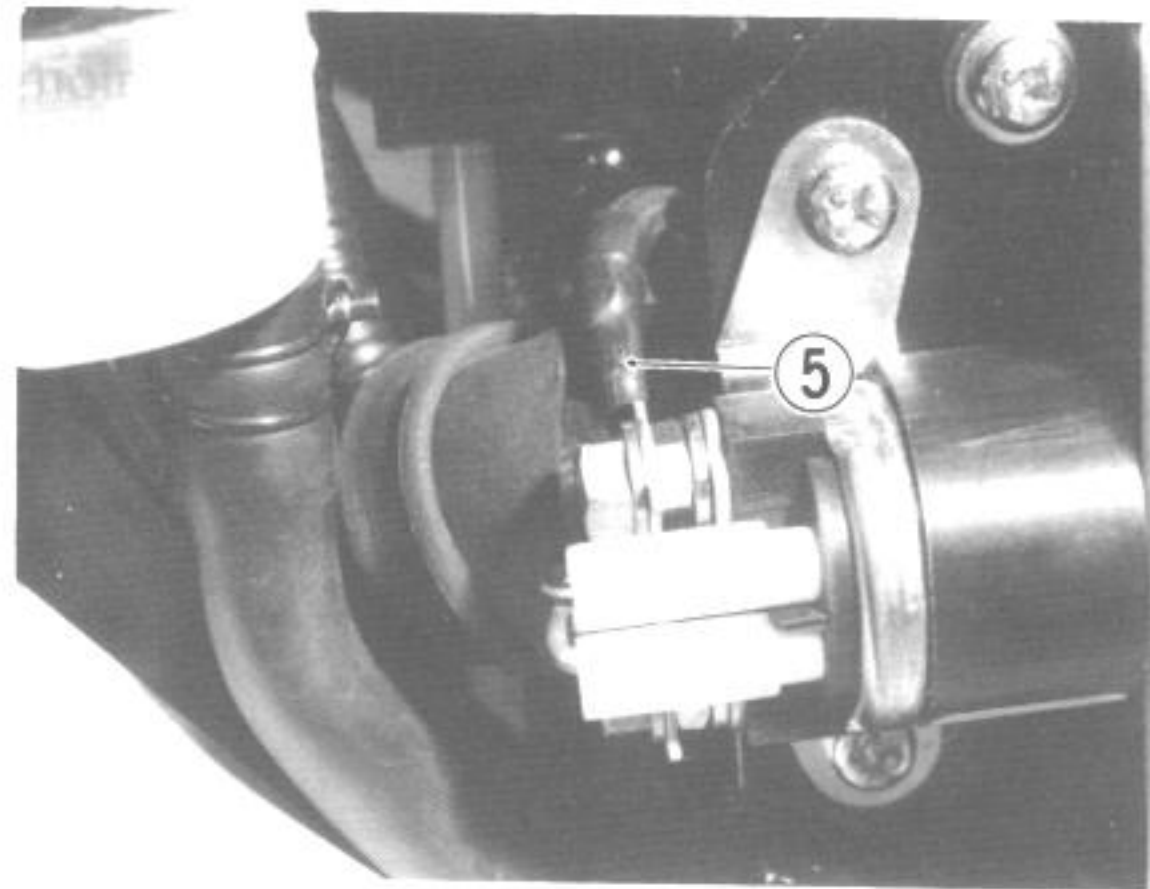
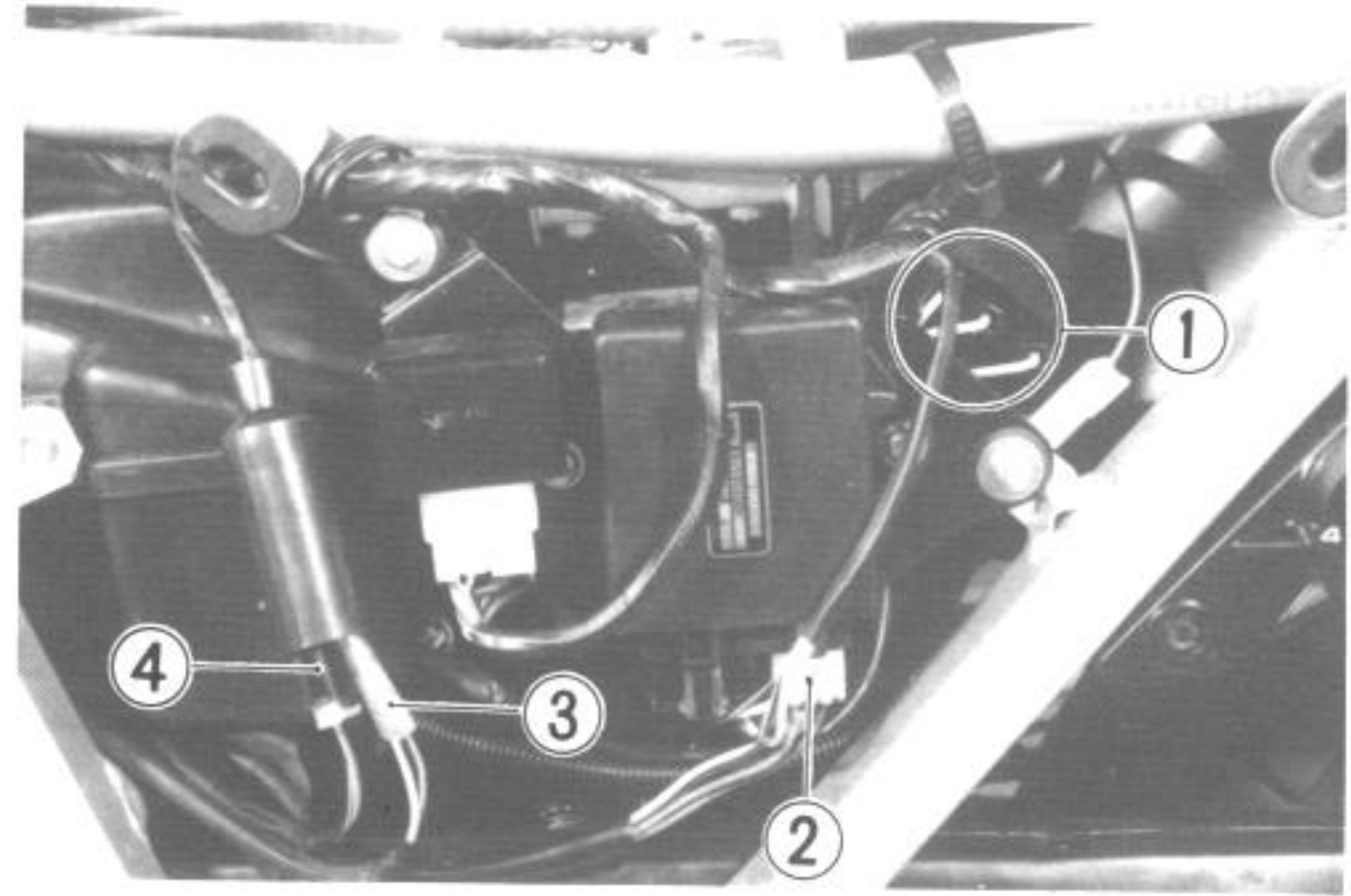

- Take off the engine sprocket from the drive chain.

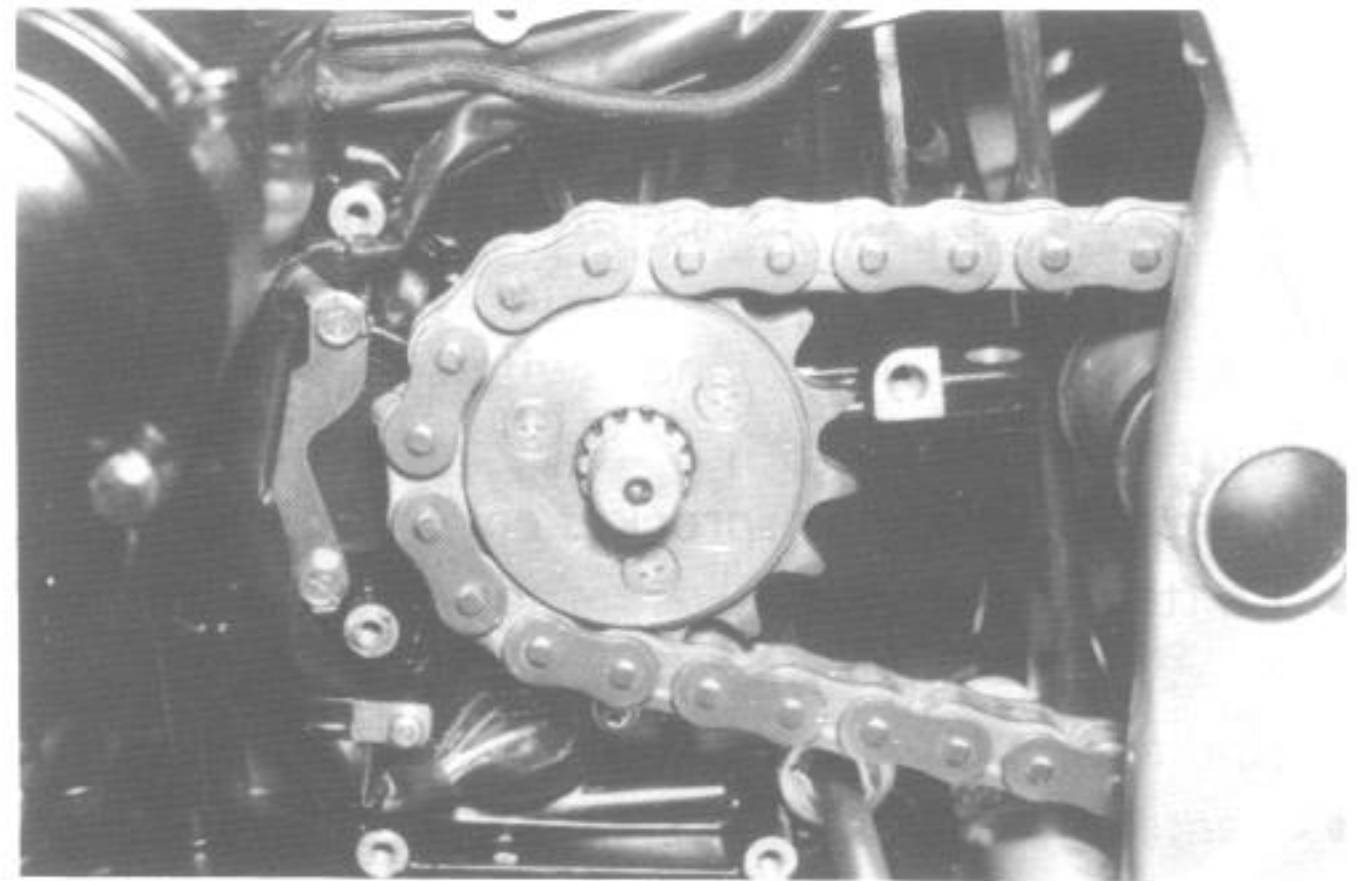

- Place an oil pan under the engine and remove the two oil cooler hoses by removing the union bolts ①.

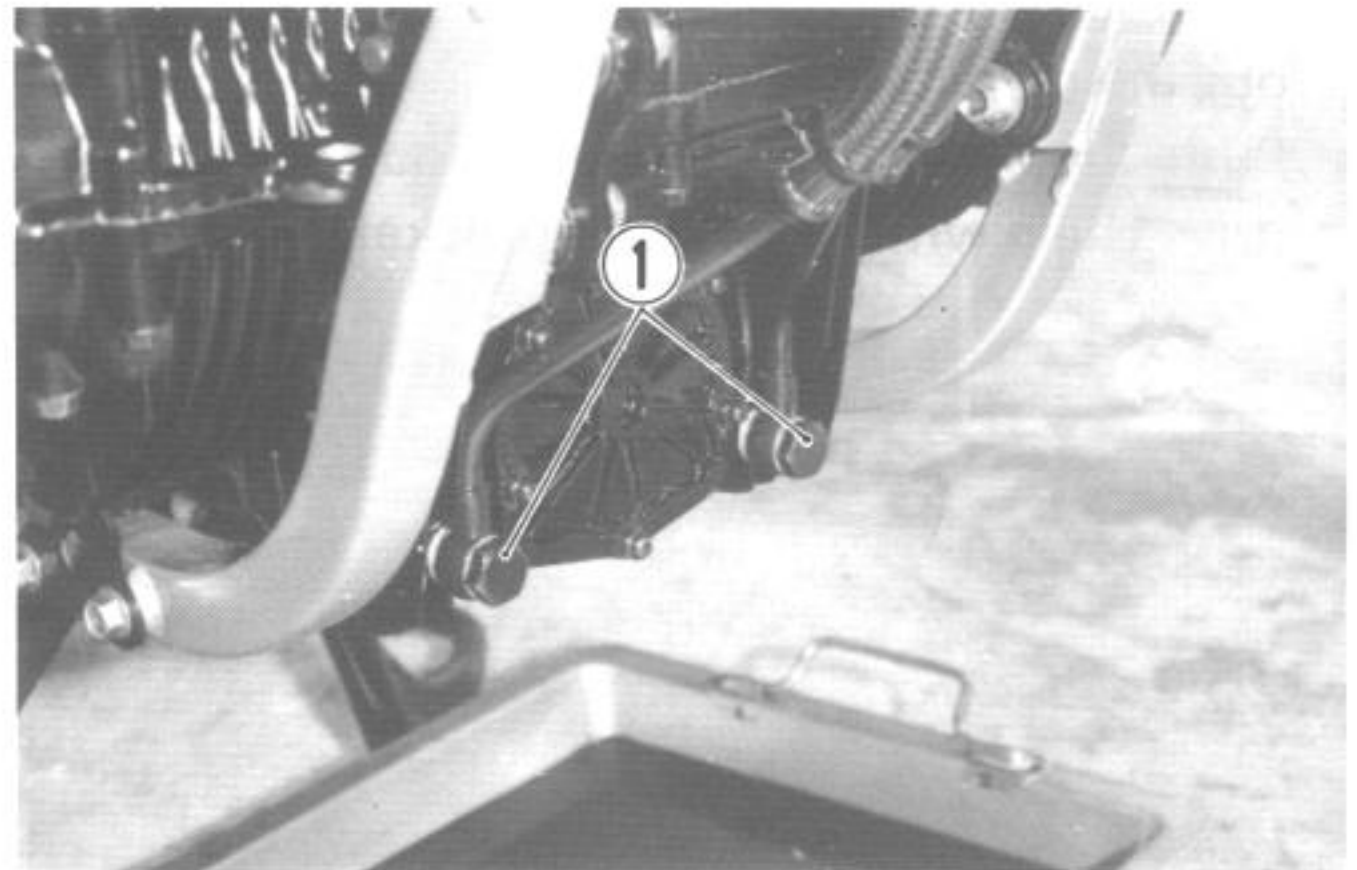

- Loosen the clamp screw and take off the air cleaner case ②.
- Remove the engine mounting brackets, bolts and nuts.

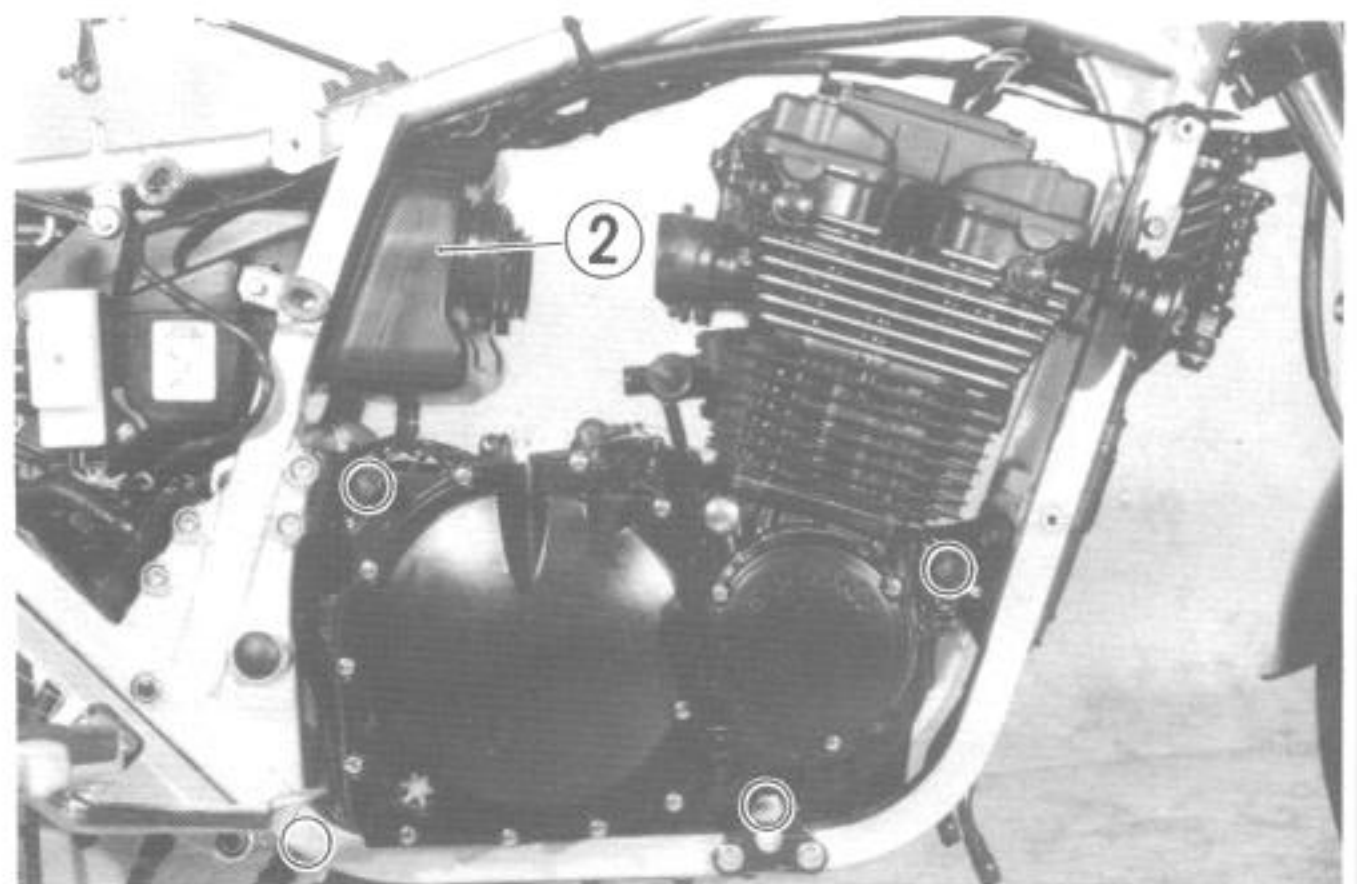

- Gradually lift up the engine, and lower the engine ass'y on the right side making sure that it does not make contact with the rear bracket. Remove the engine through the right side of the frame.



ENG
Reinst
remov
• Aft
tigh
eng
Inse
stall
ly as

NO
The
Onc
long
and



ENGINE REINSTALLATION

Reinstall the engine in the reverse order of engine removal.

- After inserting the engine mounting bolts, tighten the engine mounting bracket bolts and engine mounting bolts.

Insert the all three long bolts from left side. Install the brackets, bushes, bolts and nuts properly as shown in the following illustration.

NOTE:

The engine mounting nuts are self-lock nuts. Once the nut has been removed, it is no longer of any use. Be sure to use new nuts and tighten them to the specified torque.

TIGHTENING TORQUE

ITEM	N·m	kg-m
Ⓐ, Ⓑ	70 – 88	7.0 – 8.8
Ⓒ	55 – 66	5.5 – 6.6
Ⓓ	50 – 60	5.0 – 6.0

LENGTH

①	290 mm
②	180 mm
③	165 mm
Ⓓ	60 mm

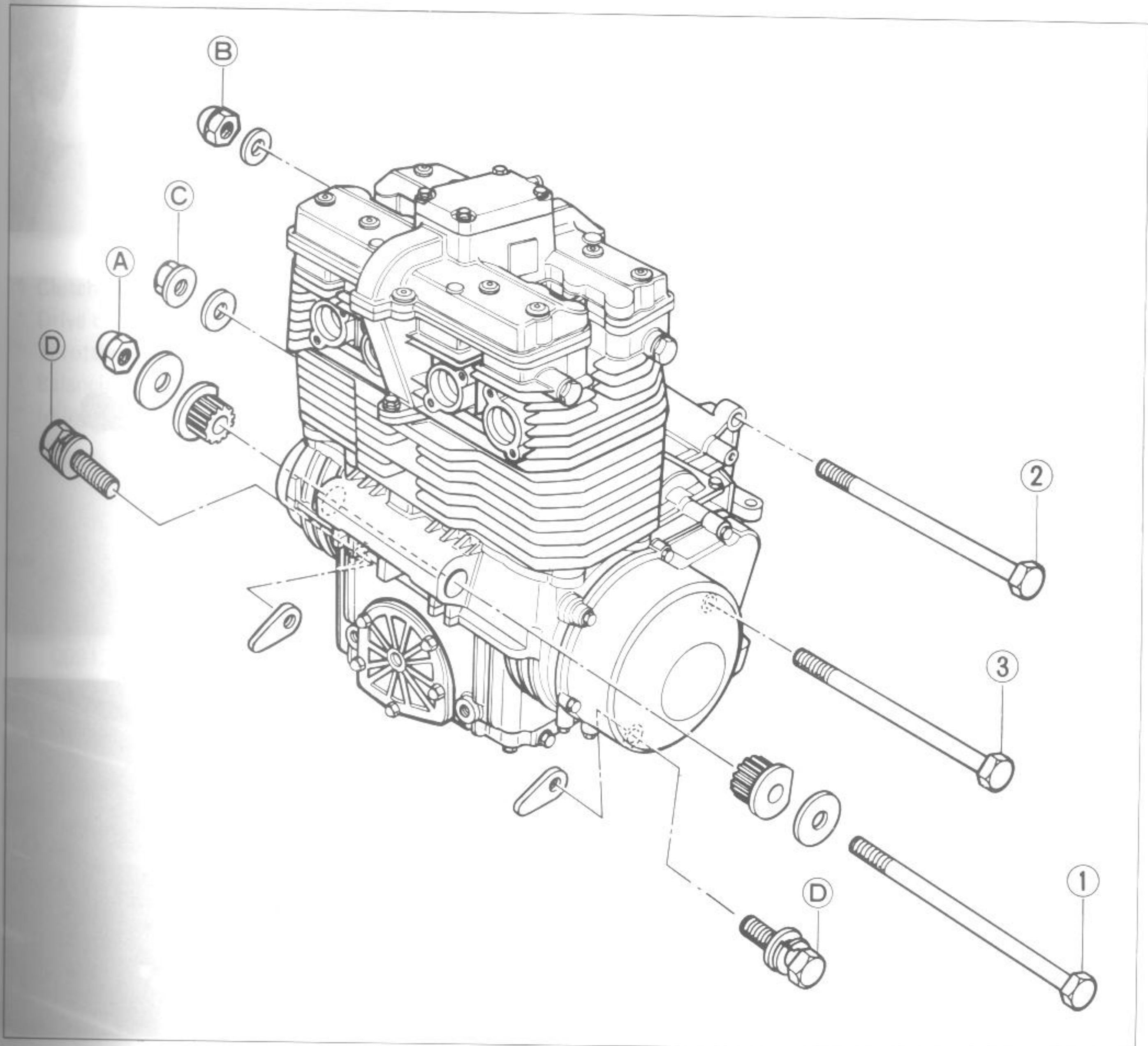

- The engine sprocket should be installed on the drive shaft beforehand as shown in the figure at the same time of the installation of drive chain. If it is difficult to assemble the engine sprocket, remove the rear axle cotter pin, loosen the axle nut, and chain adjuster bolt to push the wheel forward, and give the drive chain some play. After completing tightening of the engine mounting bolts, adjust the drive chain free play (see page 2-17).

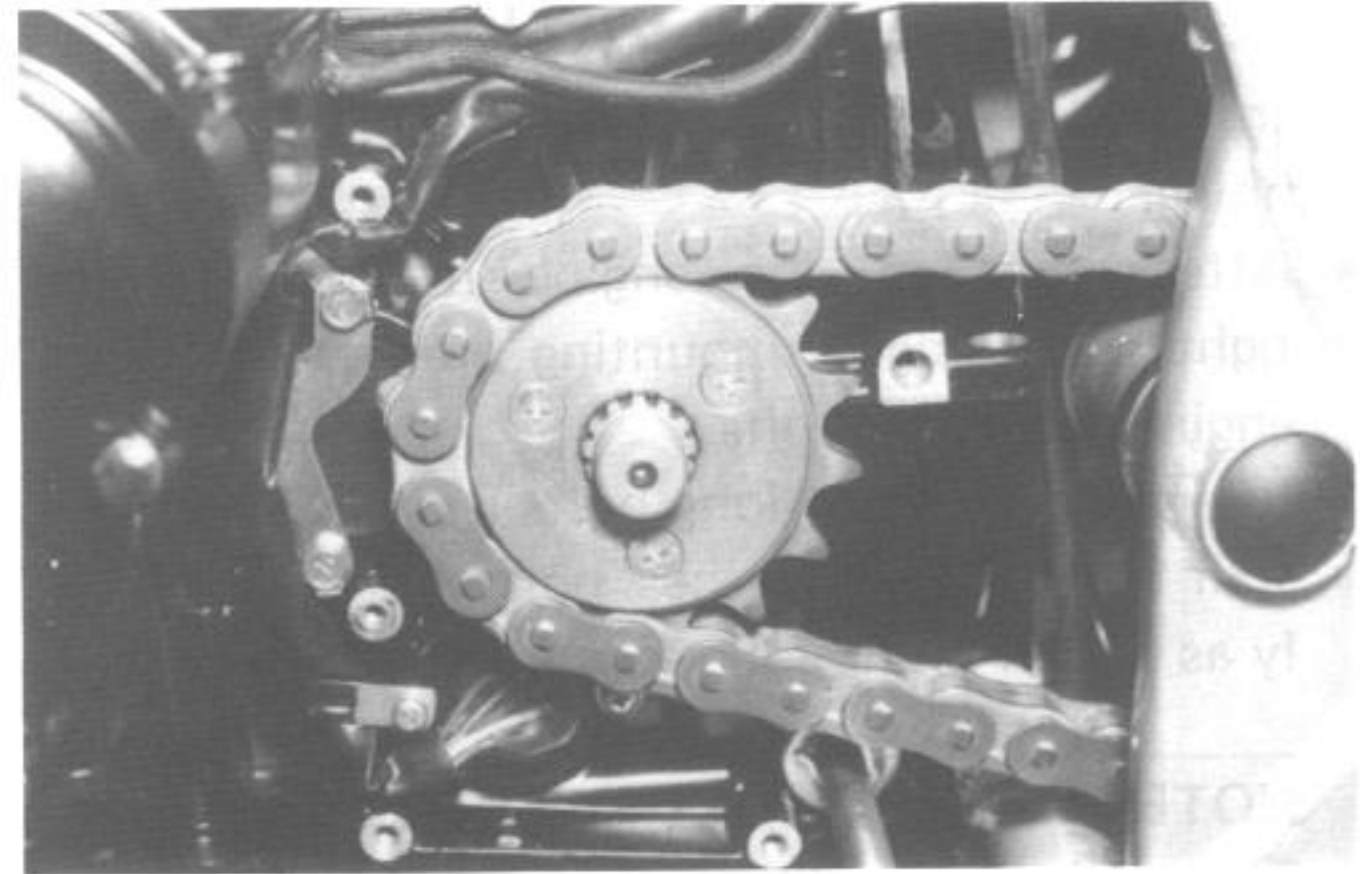

NOTE:
The engine sprocket nut is self-lock nut. Once the nut has been removed, it is no longer of any use. Be sure to use new nut and tighten it to the specification.

Tightening torque

	N·m	kg-m
Engine sprocket nut	100 – 150	10.0 – 15.0
Rear axle nut	85 – 115	8.5 – 11.5

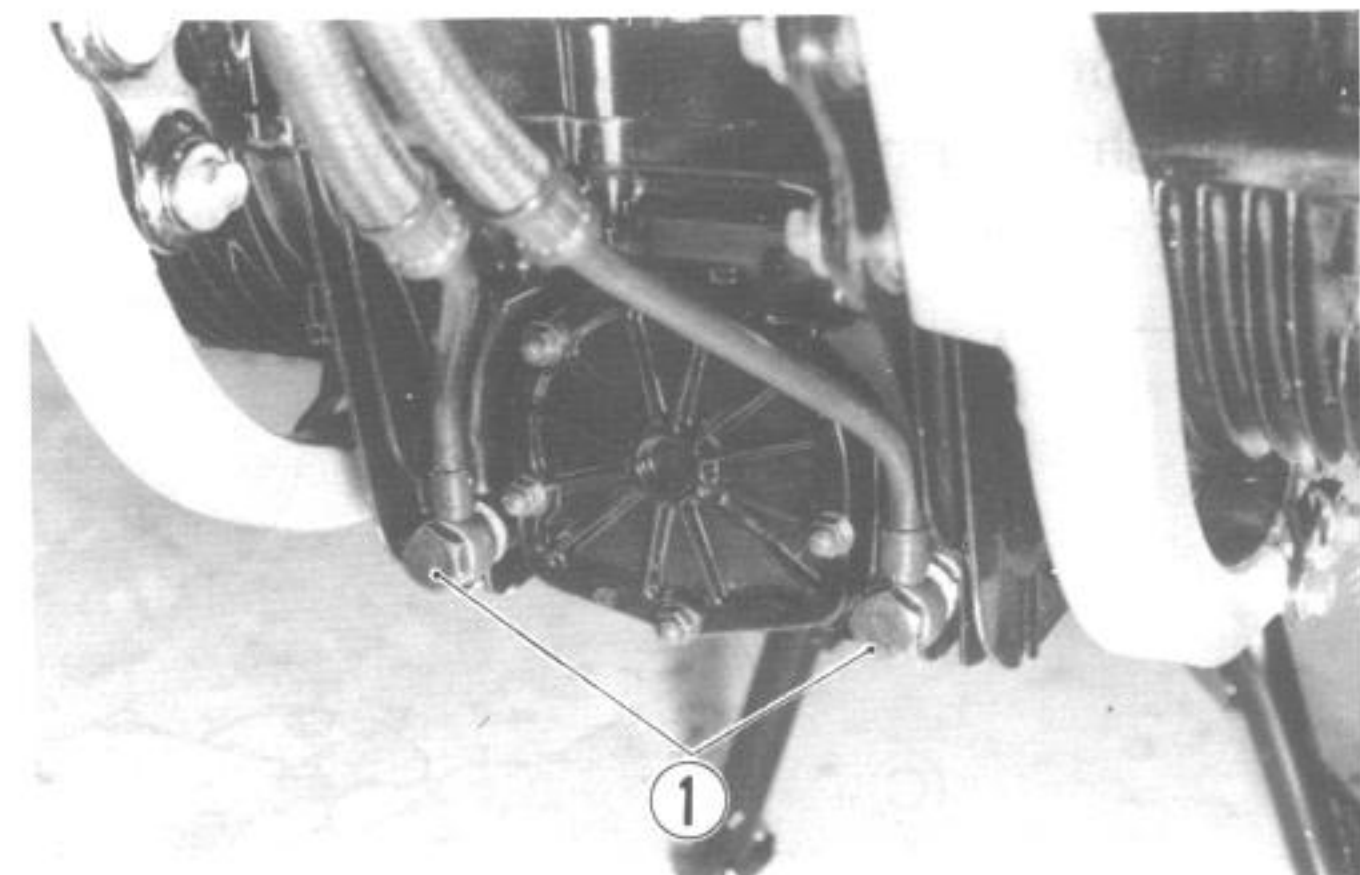

- Locate the copper washers on the both side of the union bolt and tighten the union bolts ① to the specification.

Tightening torque	25 – 30 N·m (2.5 – 3.0 kg-m)
-------------------	---------------------------------

- Install exhaust pipe plates ② in Nos. 2 and 3 exhaust pipe, and tighten exhaust pipe bolts.

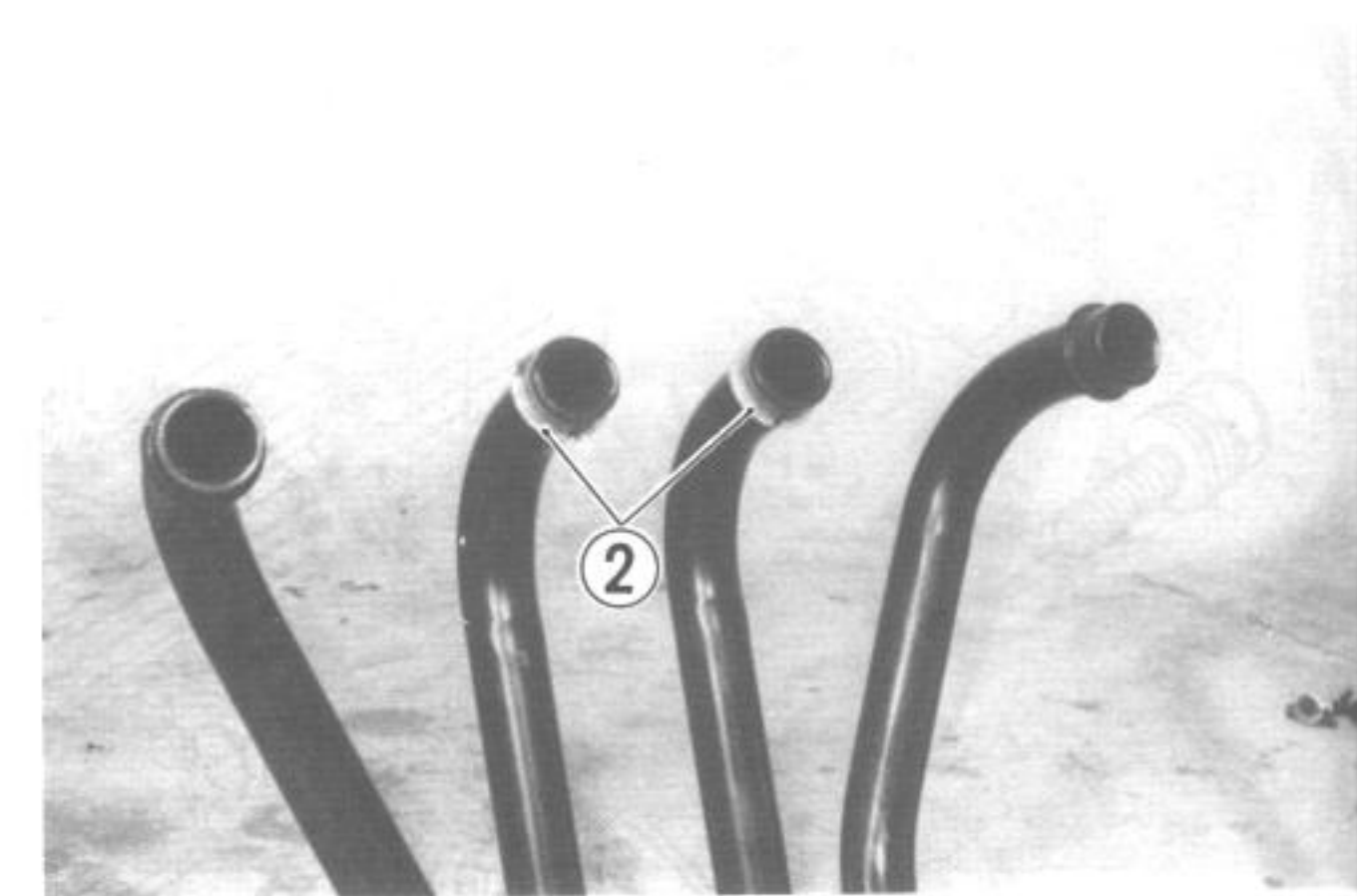

Tightening torque	20 – 25 N·m (2.0 – 2.5 kg-m)
-------------------	---------------------------------

- Securely tighten bolts ③ connecting exhaust pipe and mufflers to prevent gas leakage.

Tightening torque	9 – 14 N·m (0.9 – 1.4 kg-m)
-------------------	--------------------------------

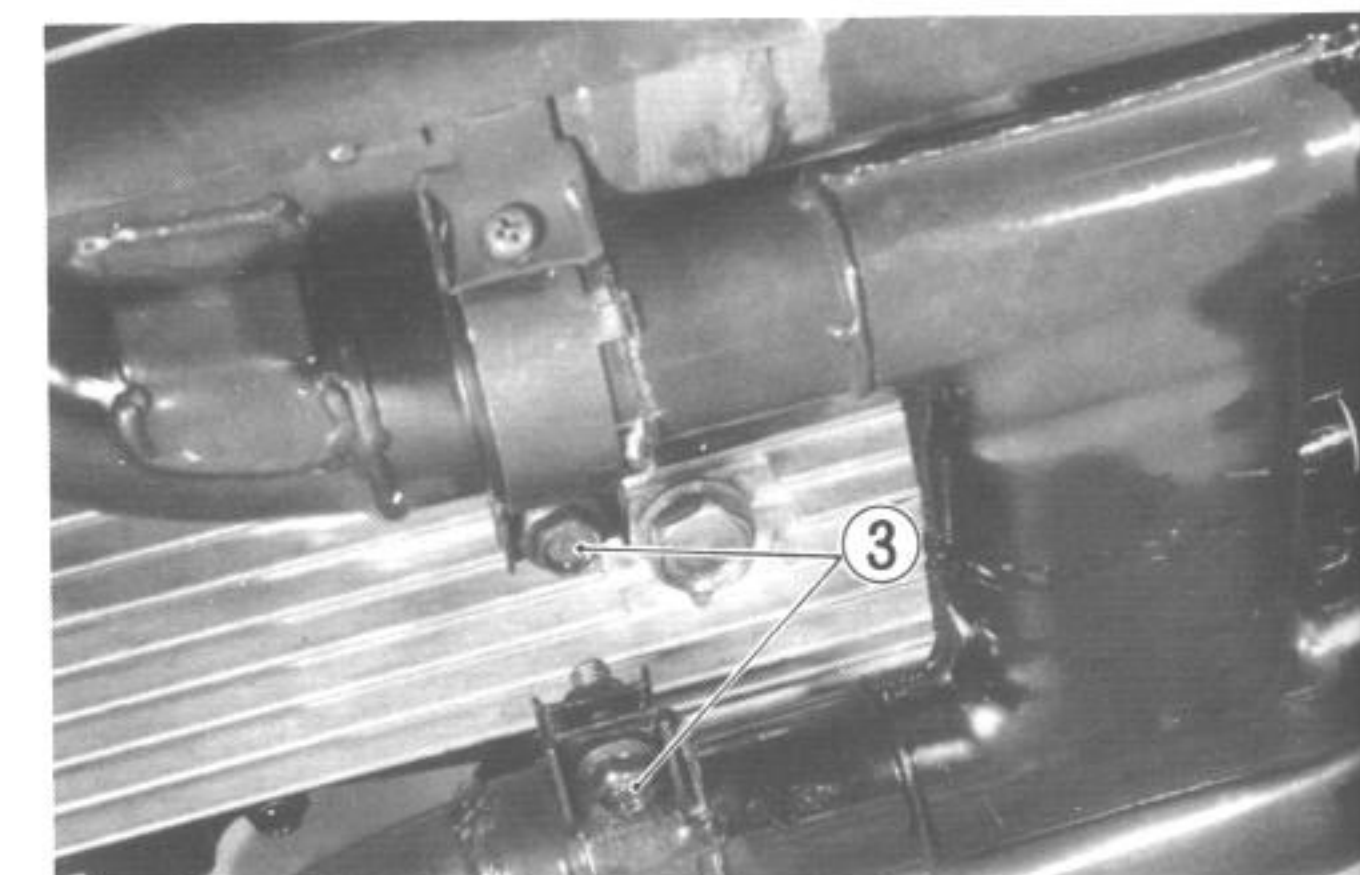

• Be
m
w
fo

• Re
the
nu
fro

* Clu
* Dri
* Thr
* Bal
* Idli

- Before starting the engine, make sure the amount of oil required, according to the type of work done, has been put in. Refer to page 2-14 for quantities.



- Replace the plug caps on the spark plugs so that their code markings correspond to the cylinder numbers arranged in the order of 1, 2, 3 and 4 from the left.

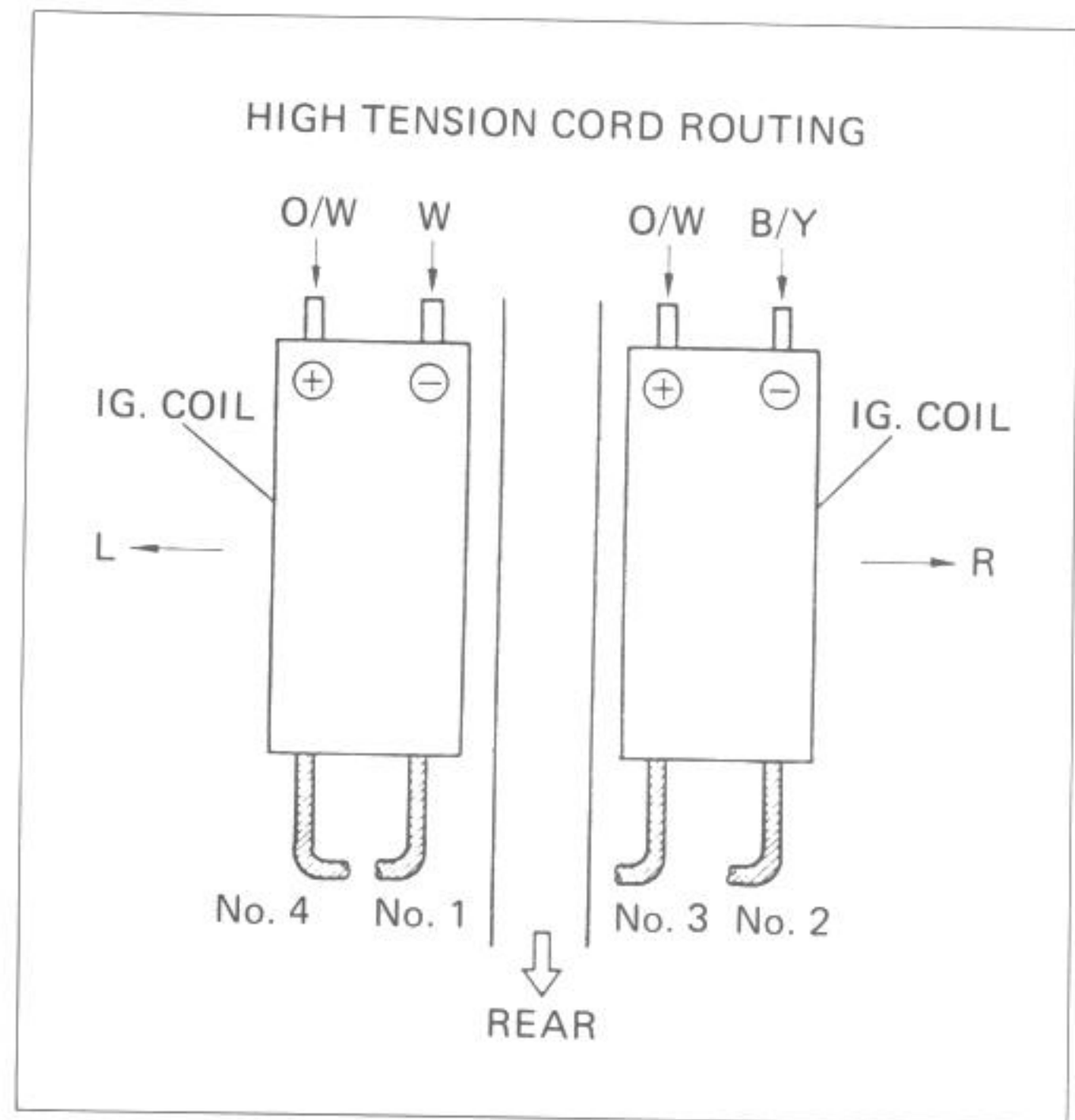

* Clutch cable	2-16
* Drive chain play	2-17
* Throttle cable	2-10
* Balancing carburetor	2-11
* Idling adjustment	2-13

099

CAUT-

ENGINE DISASSEMBLY

- Remove the 10 bolts by using the 6 mm hexagon wrench and take off the cylinder head cover.

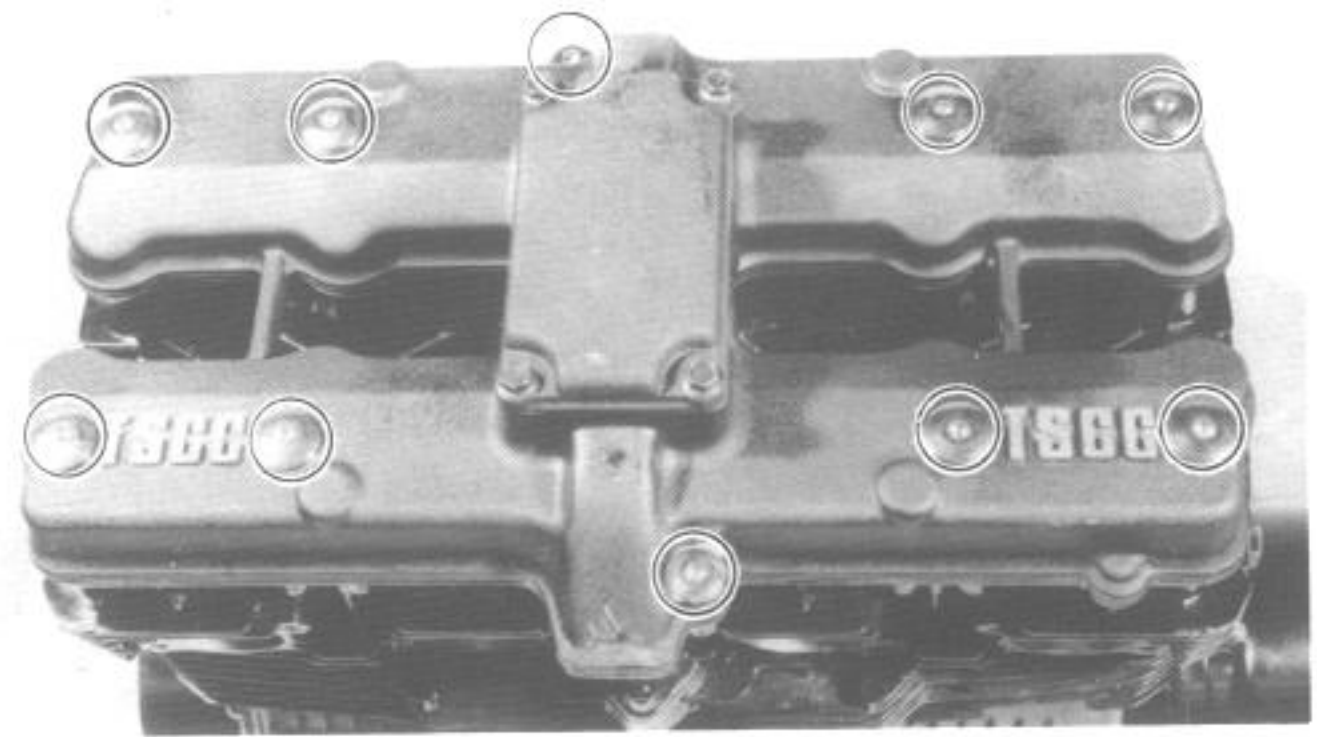

- To remove the chain tensioner is accomplished by first loosening lock nut ① and tightening screw ② and then by removing two mounting bolts ③.

NOTE:

Tightening screw ② locks the spring loaded tensioner pushrod inside.

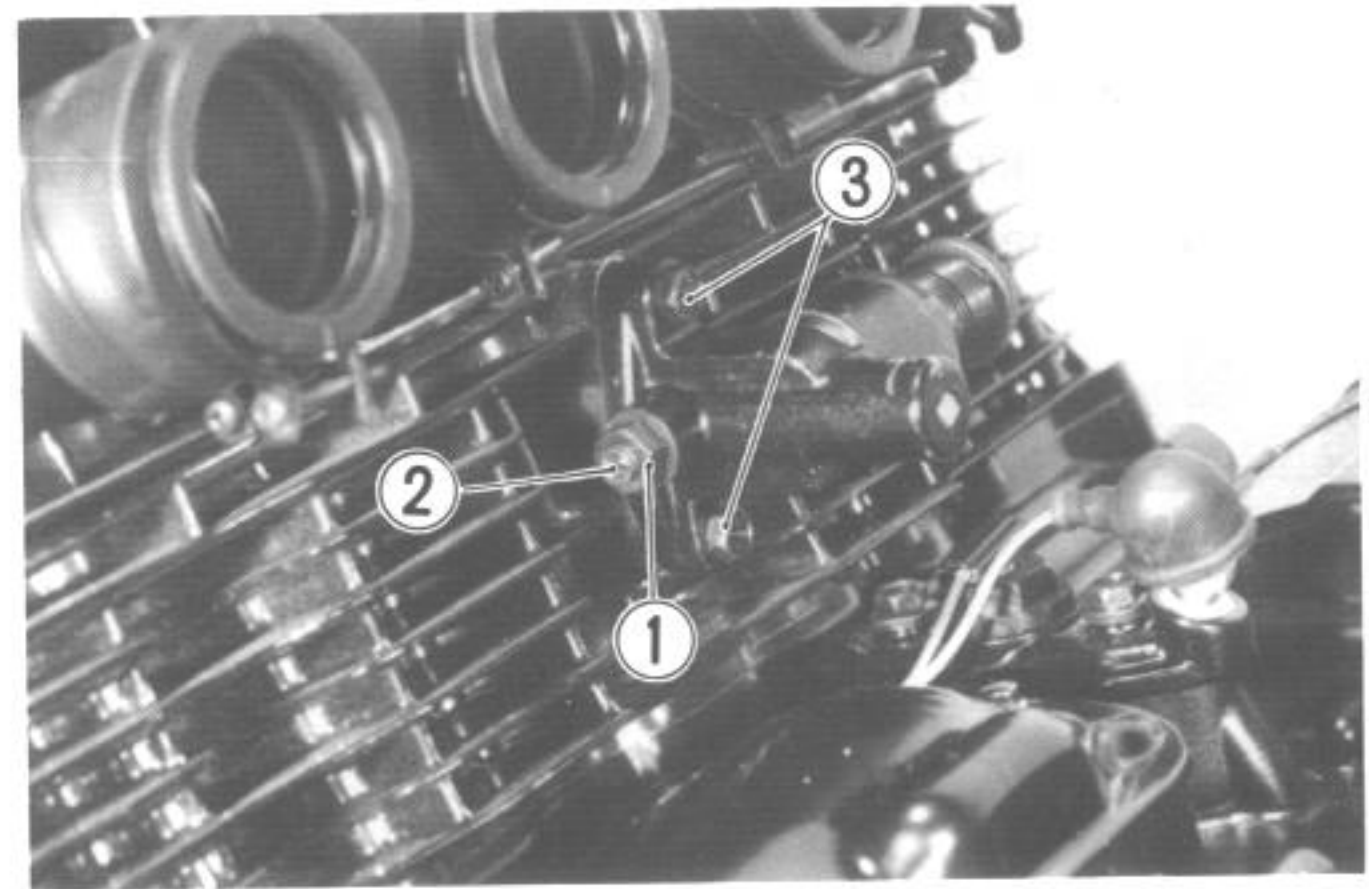

- Remove the two camshafts, intake and exhaust.

NOTE:

Be sure to loosen the camshaft holder bolts evenly by shifting the wrench diagonally after loosening a bolt.

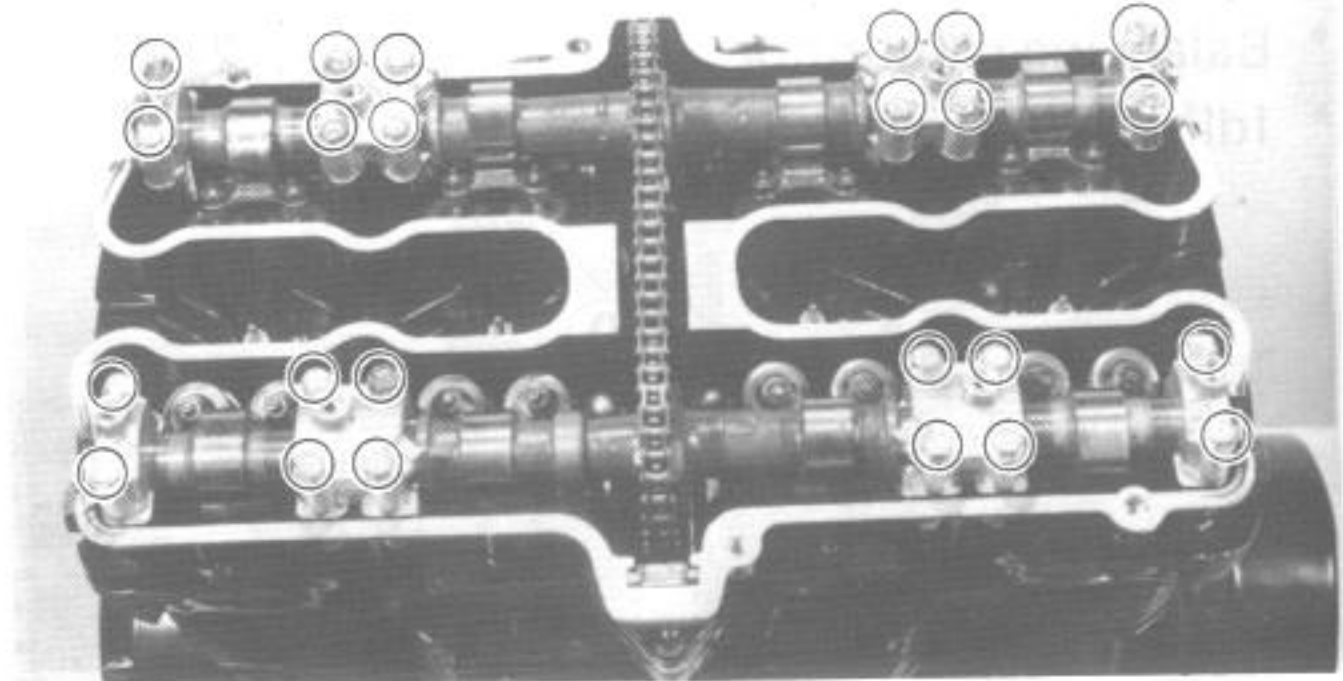

- Pull out the cam chain guide.

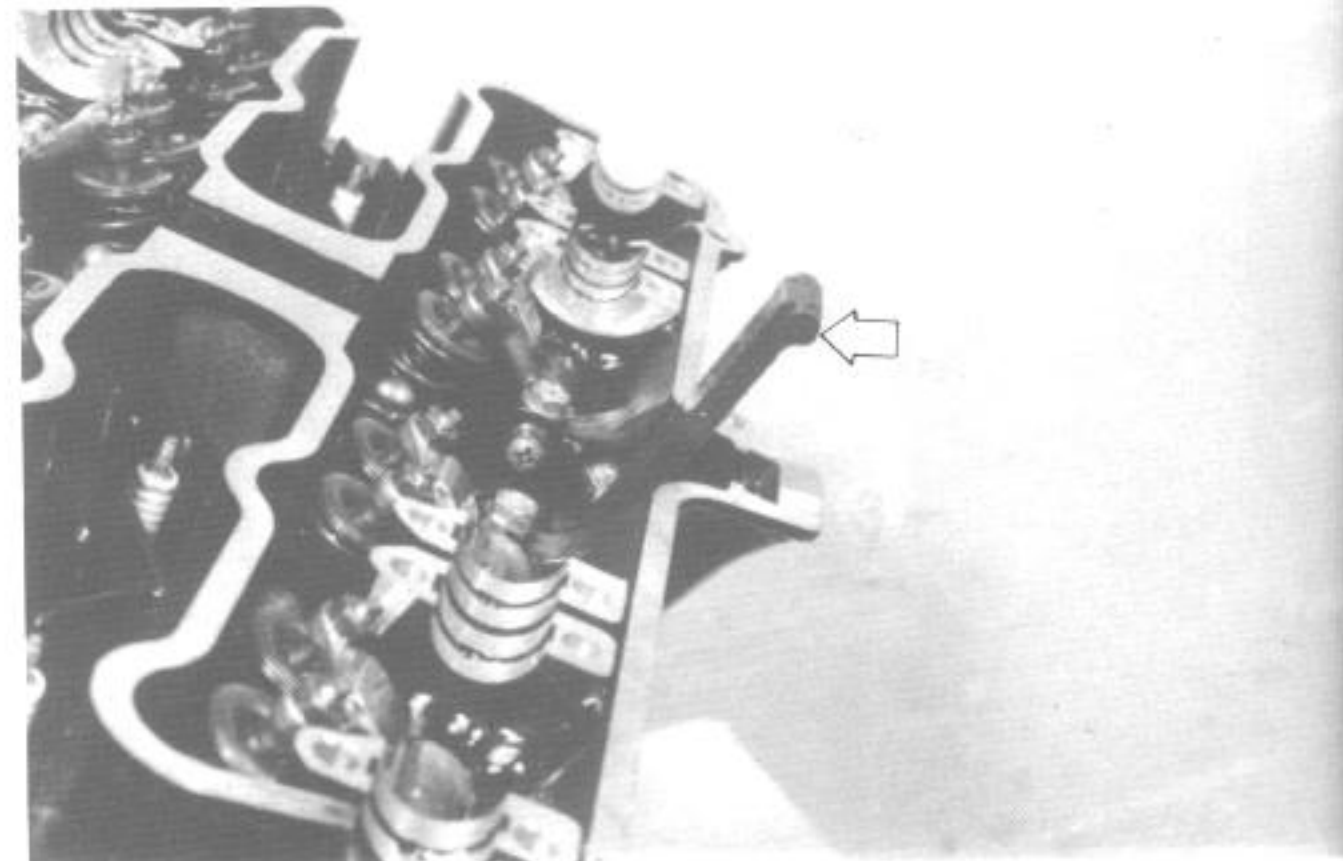

• The
wh
ren

0
0

NO
Wh
eac
ing
a cy

• Firm
lift
off,
bloc
join

NOT
Cyli
easi
tool

09

CAU
Be
remo
This
also.

• Scrib
respe

- The cylinder head becomes free for removal when its one bolt ①, and twelve nuts are removed.

09911-74510	Long socket 14 mm
09914-24510	T handle

NOTE:

When loosening the cylinder head nuts, break each nut loose a little at a time in a descending order according to the numbers cast on a cylinder head.

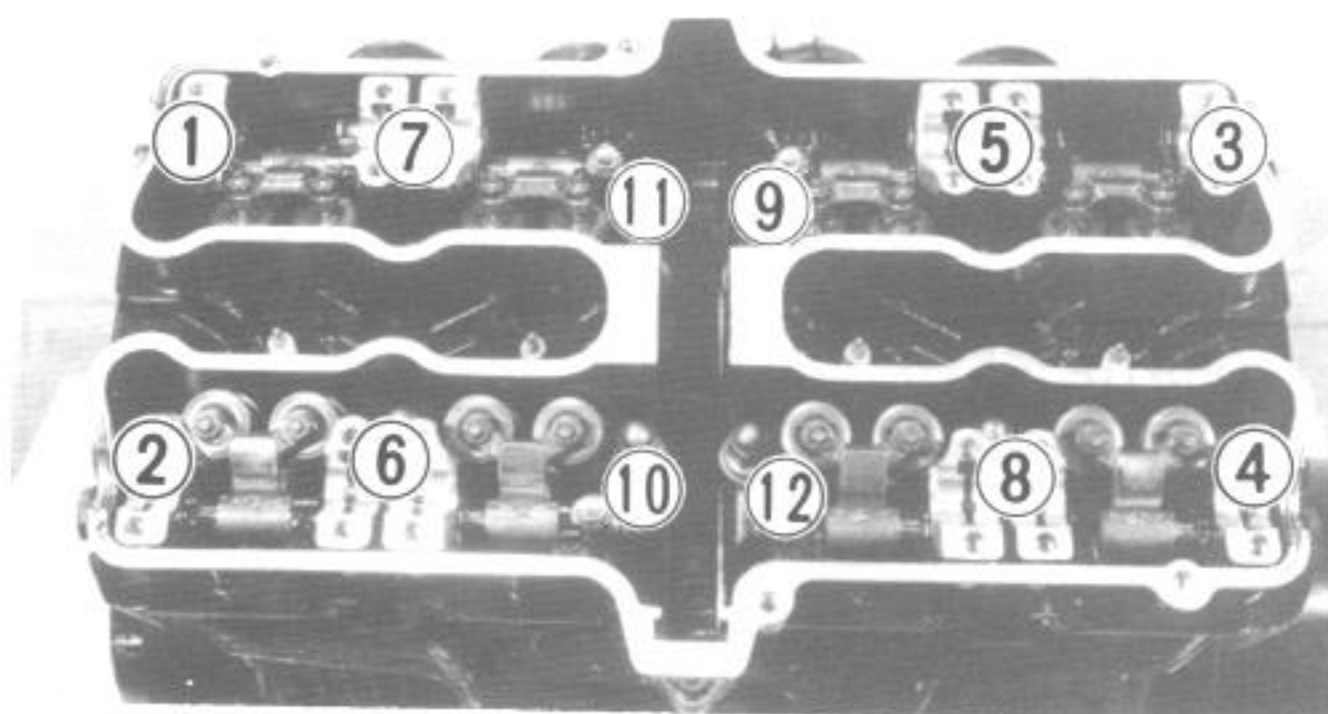
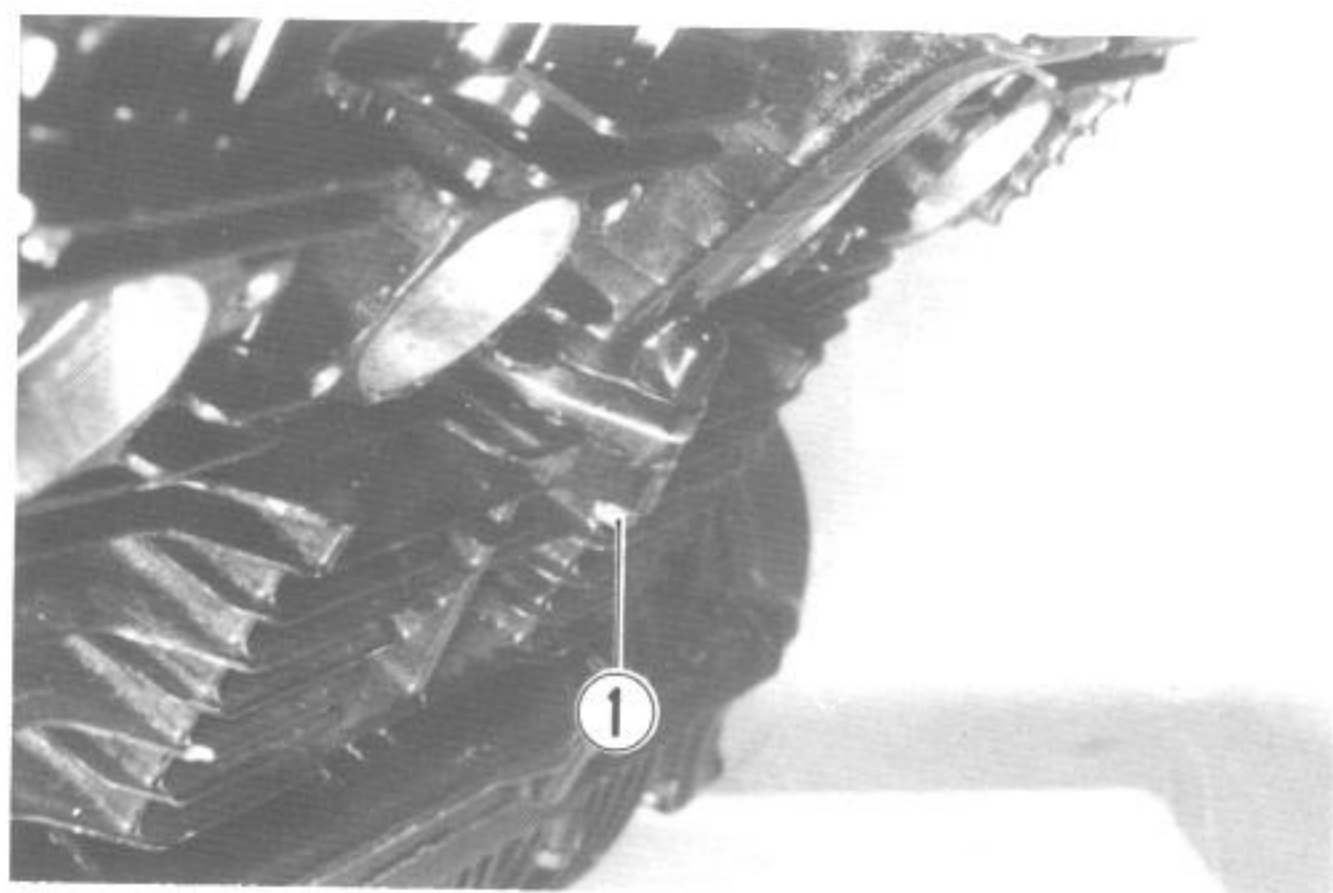

- Firmly grip the cylinder block at both ends, and lift it straight up. If the block does not come off, lightly tap on the finless portions of the block with a plastic mallet to shake the gasketed joint loose.

NOTE:

Cylinder removal from the crankcase is made easier by the use of the cylinder disassembling tool.

09912-34510	Cylinder disassembling tool
-------------	-----------------------------

CAUTION:

Be careful not to damage the fins when removing or handling the cylinder block. This precaution applies to the cylinder head also.

- Scribe the cylinder No. on the head of the respective position.

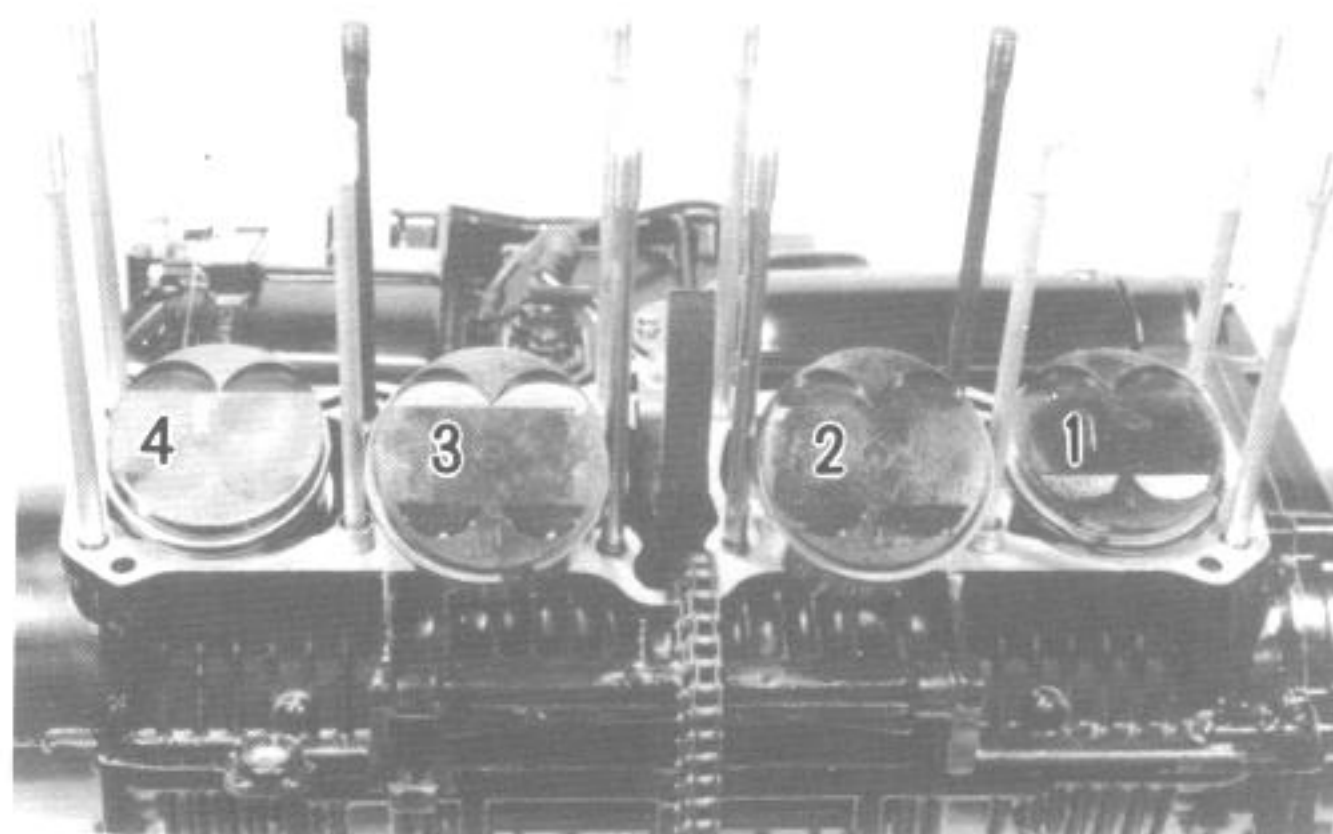
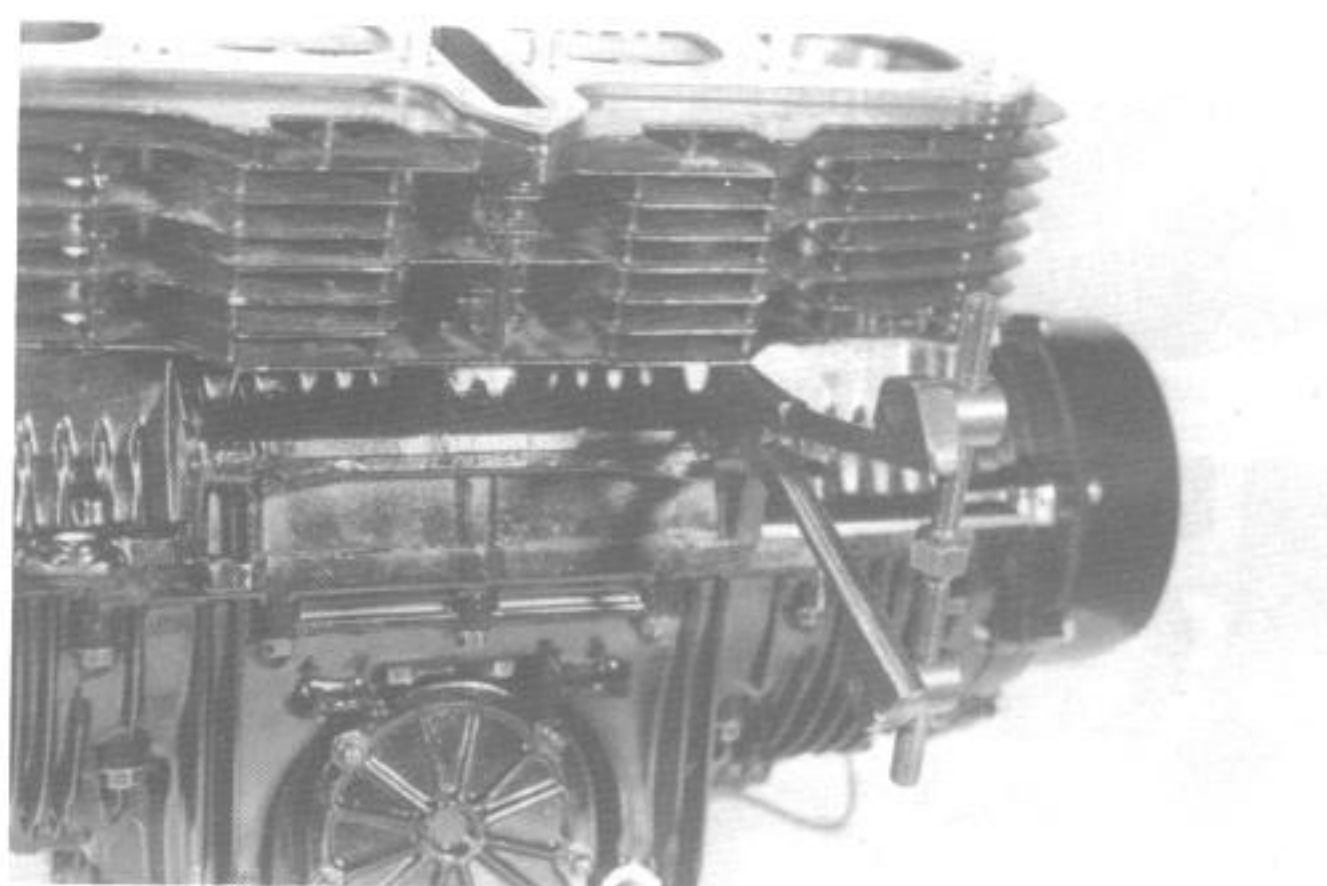

- Place a cloth beneath the piston so as not to drop the parts in the crankcase, and remove the circlip.

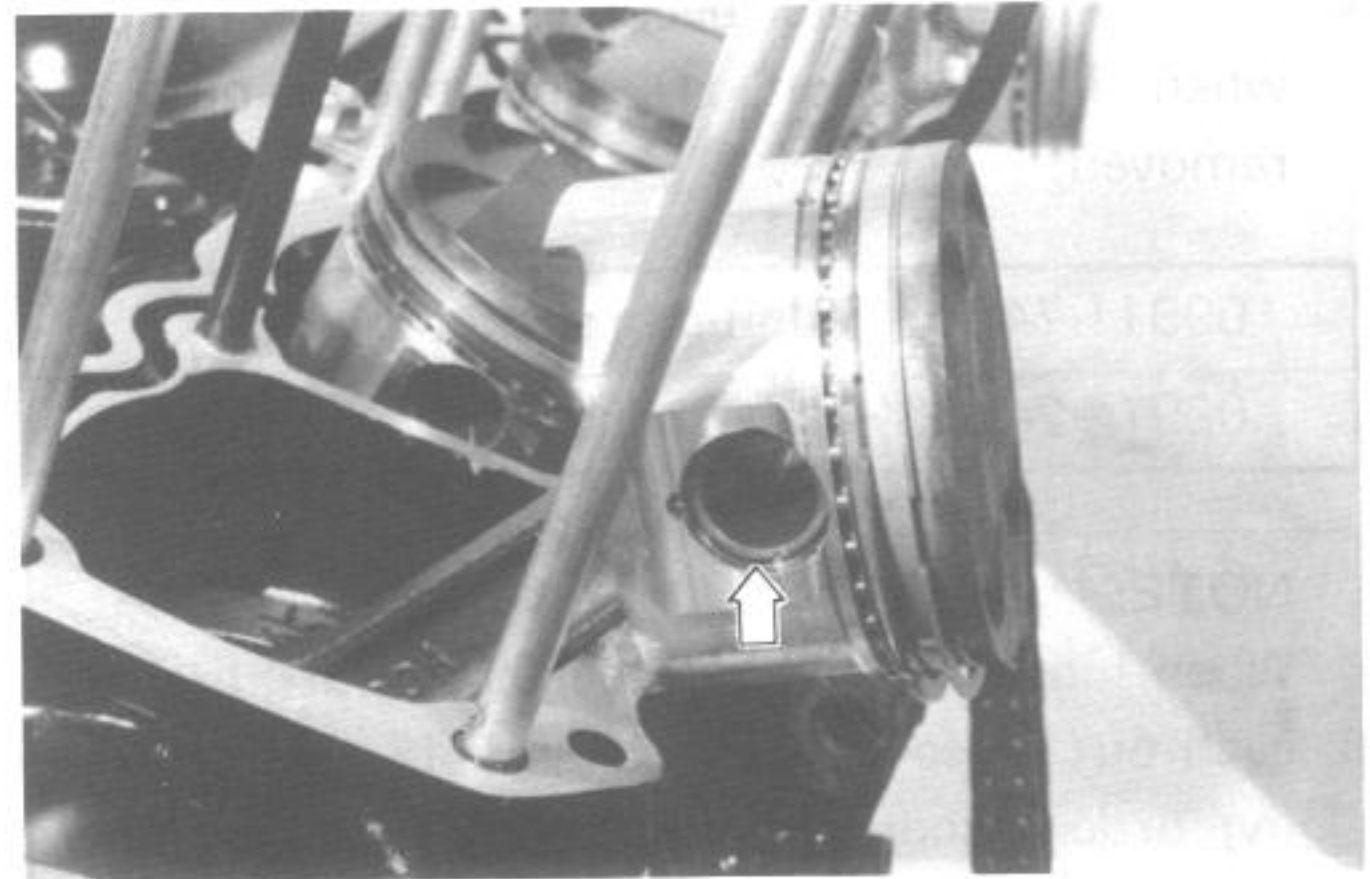

- Scribe the cylinder No. on the head of the piston, and draw out the piston pin with the special tool. Place the drawn-out piston pin in the same place as that given the cylinder No. on the head of the piston.

09910-34510	Piston pin puller
09910-33210	Attachment

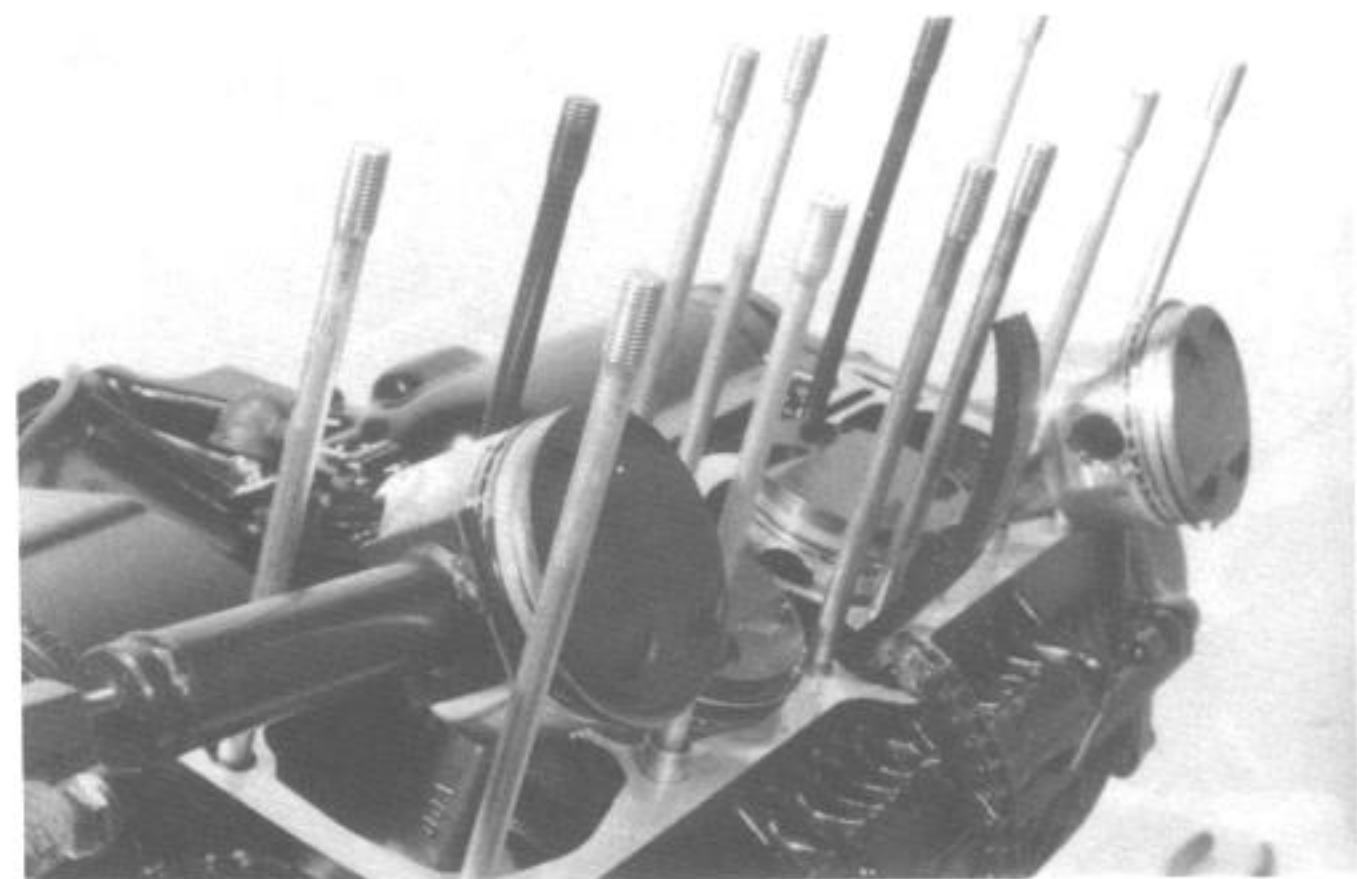

- Remove the chain guide.

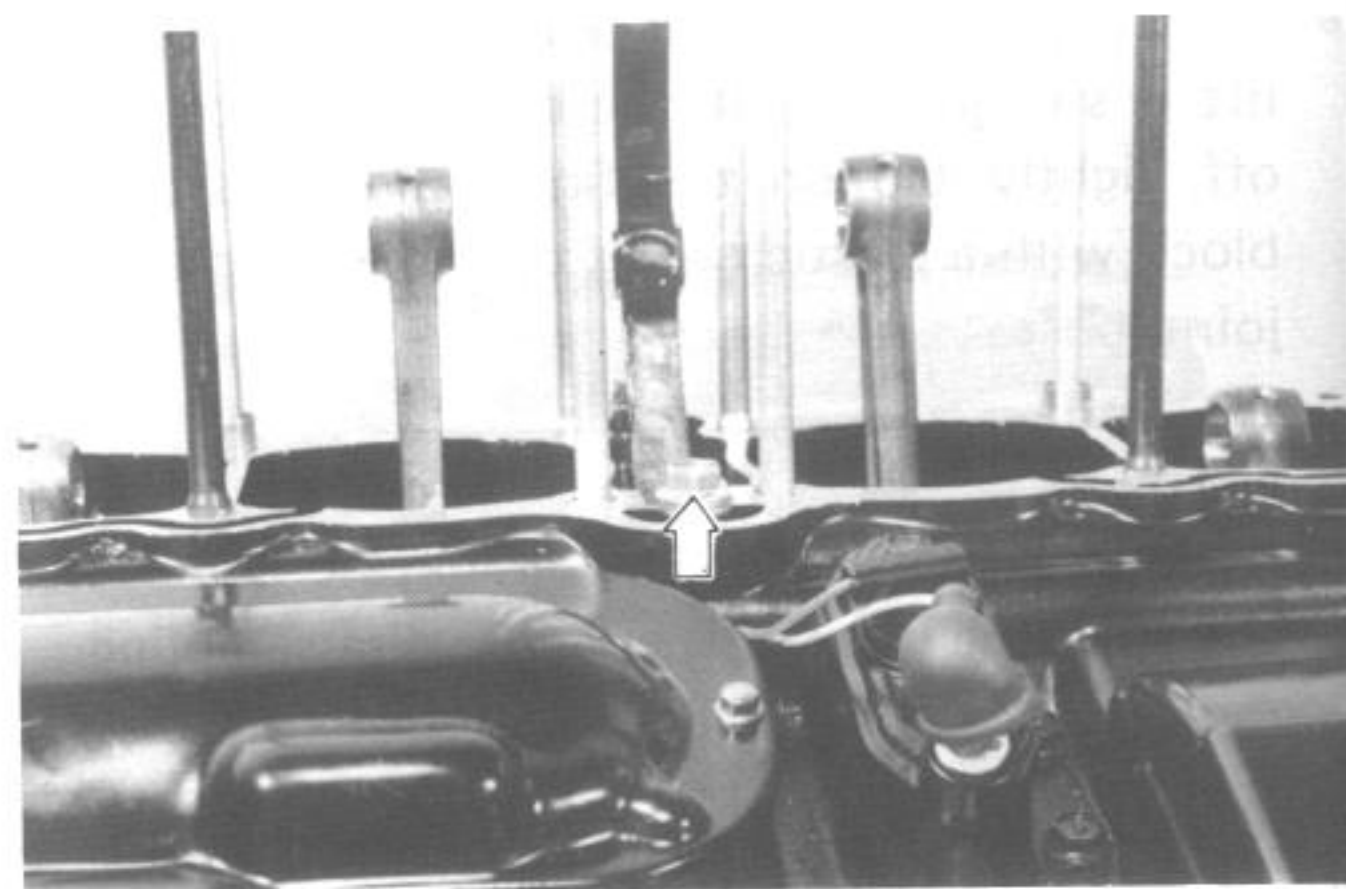

- Remove the oil pressure switch with oil temperature switch.

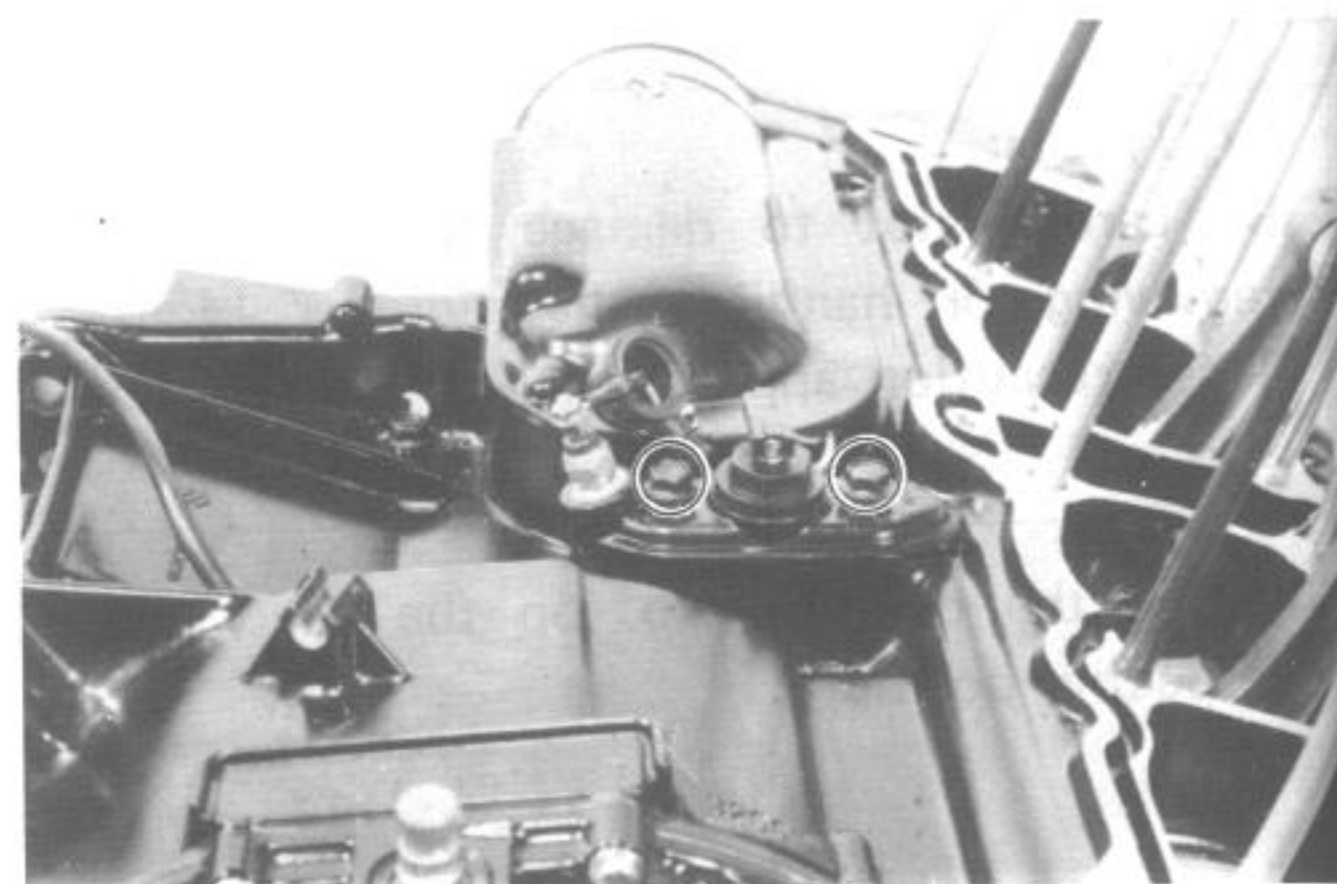

● Rem
mo

● Rem
● Rem
the
sign

● Uncl
remo
rator

● Remo

- Remove the starter motor cover and starter motor.

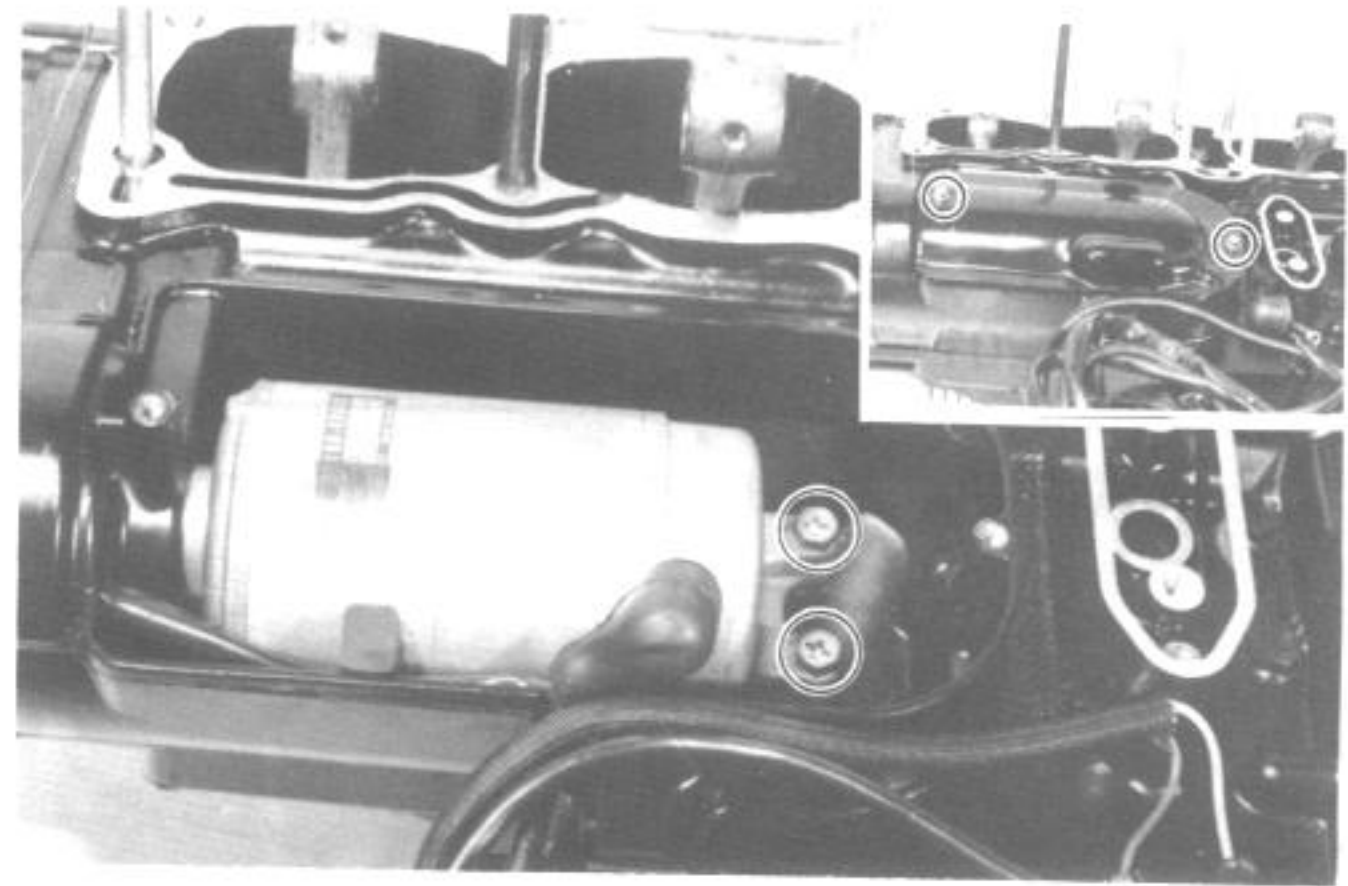

- Remove the signal generator cover.
- Remove the rotor mounting bolt by using the 6 mm hexagon wrench and take off the signal generator rotor.

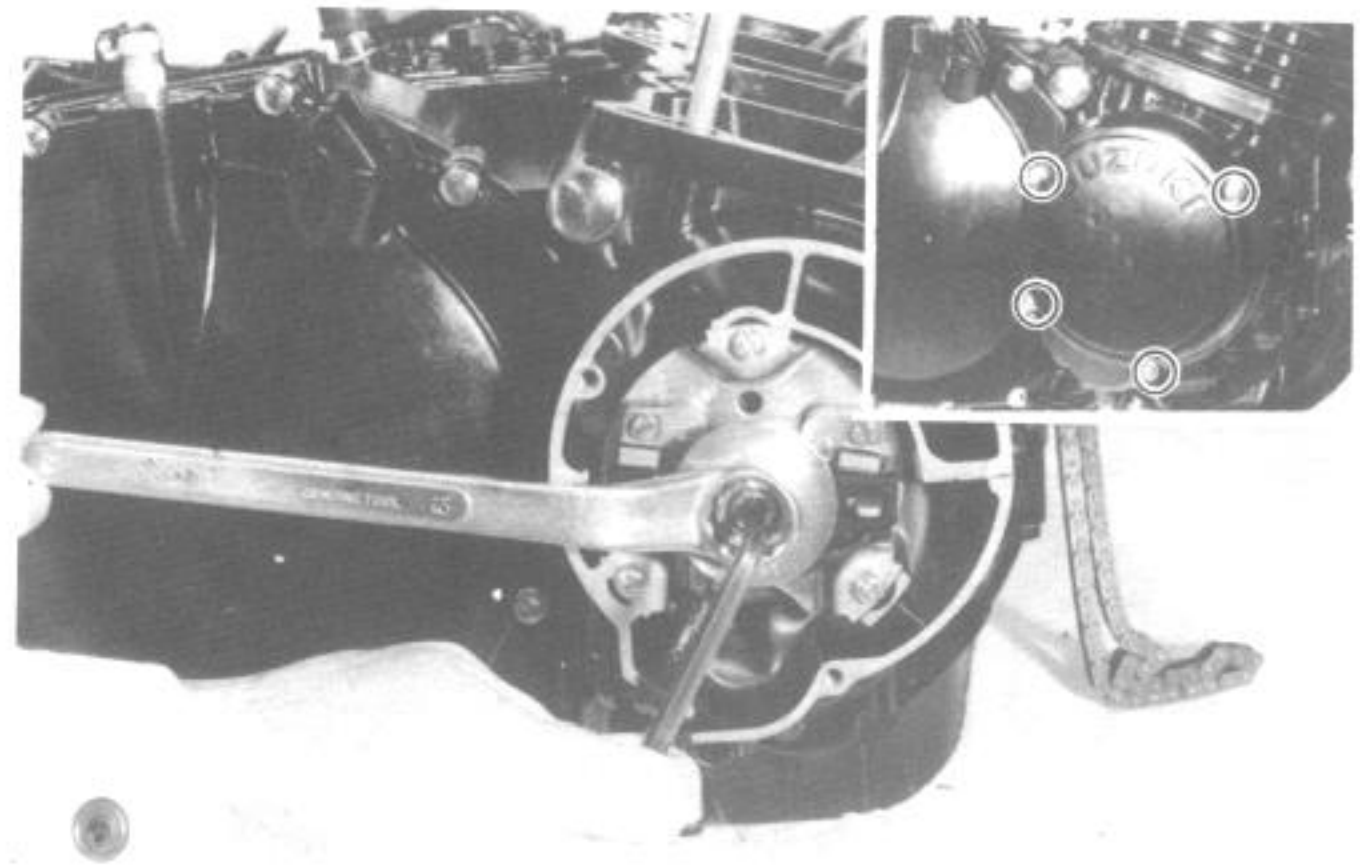

- Unclamp the signal generator lead wire and remove three screws for securing signal generator assembly.

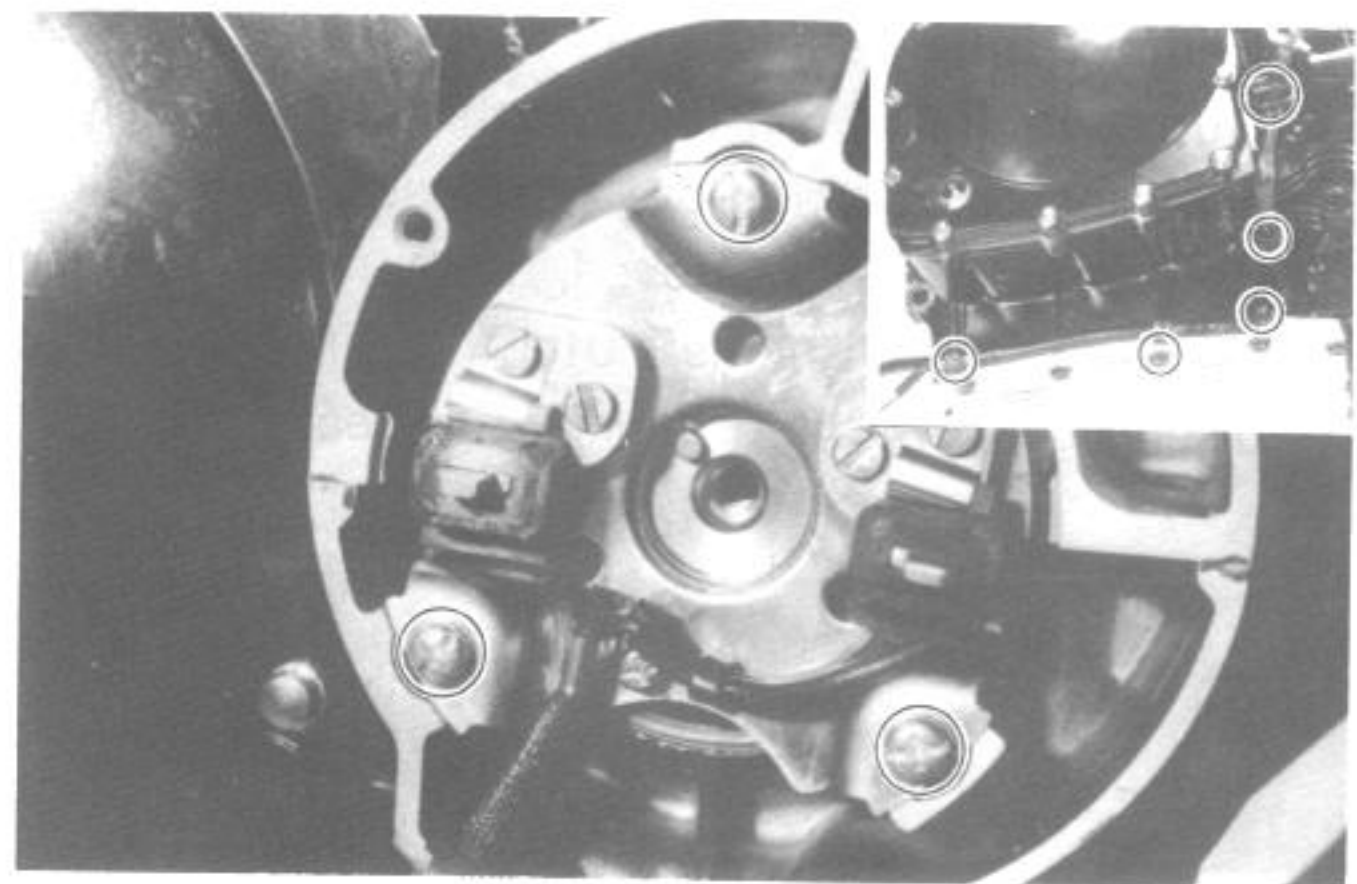

- Remove the clutch cover and gasket.

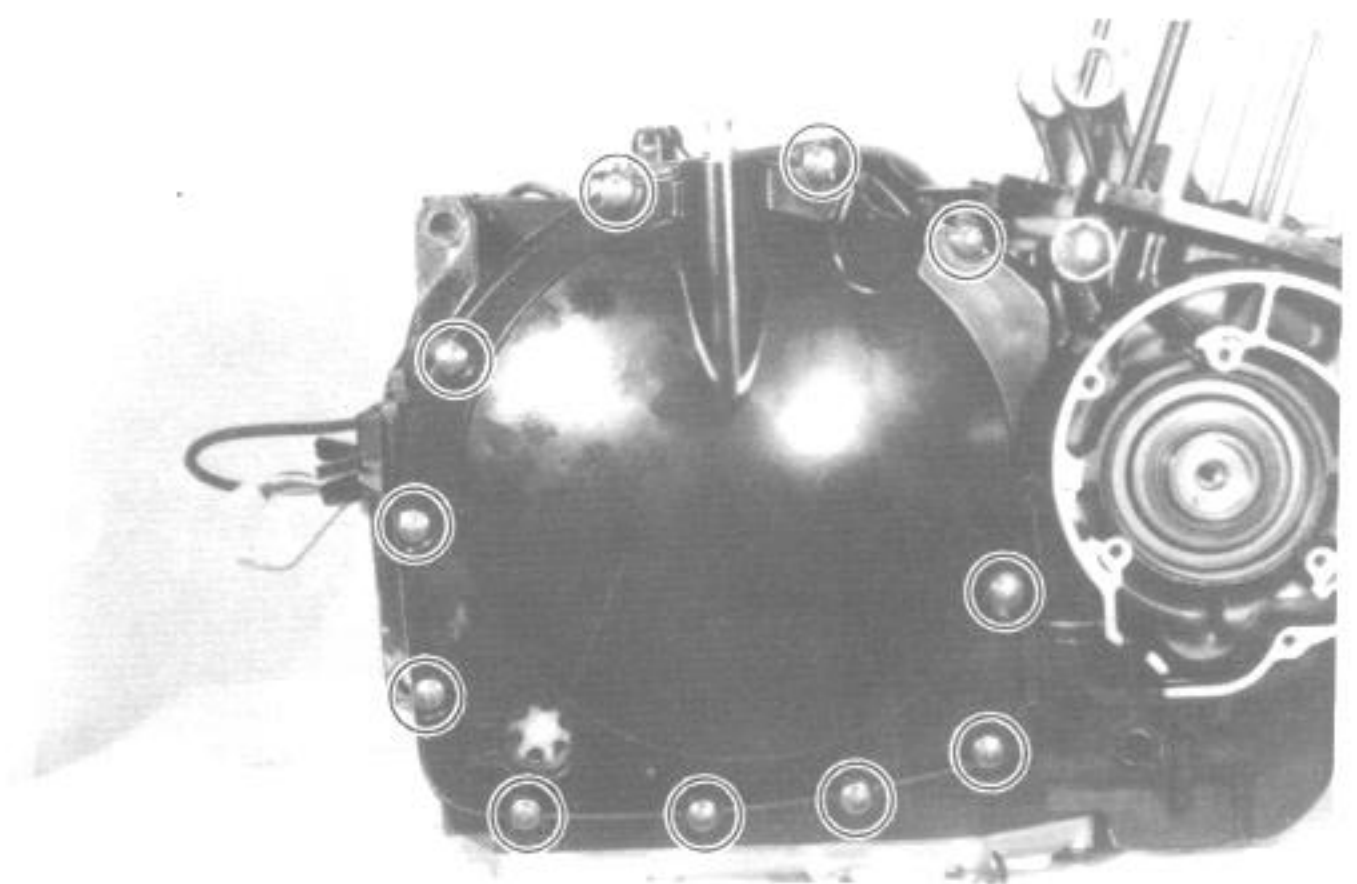

- Using conrod stopper, remove the clutch spring mounting bolts in a criss-cross manner, and remove the springs and pressure plate.

09910-20116	Conrod stopper
-------------	----------------

- Remove the clutch drive and driven plates.

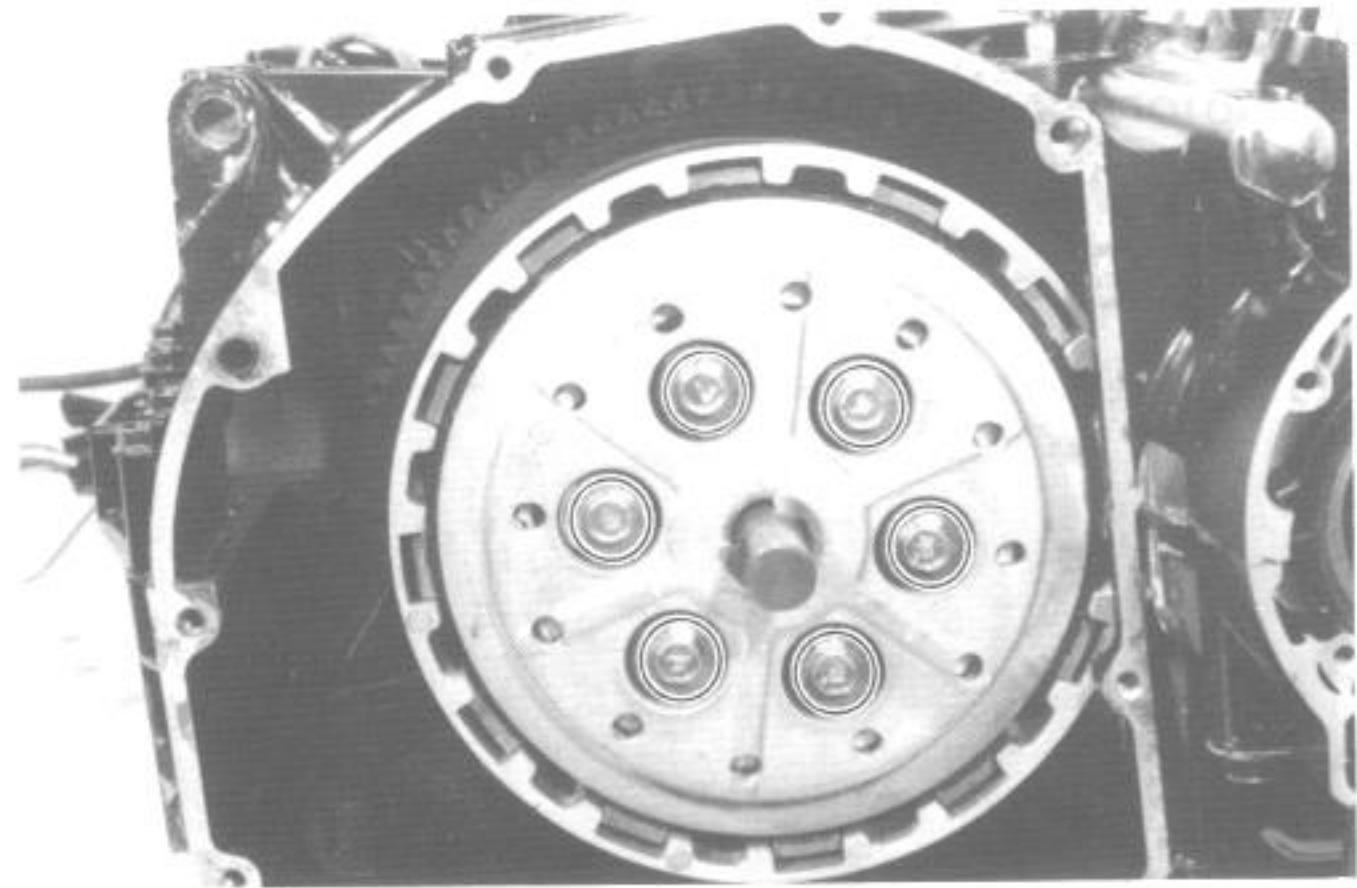

- Flatten the clutch sleeve hub nut lock washer and firmly secure clutch sleeve hub to remove the mounting nut by using the special tool.

09920-53710	Clutch sleeve hub holder
-------------	--------------------------

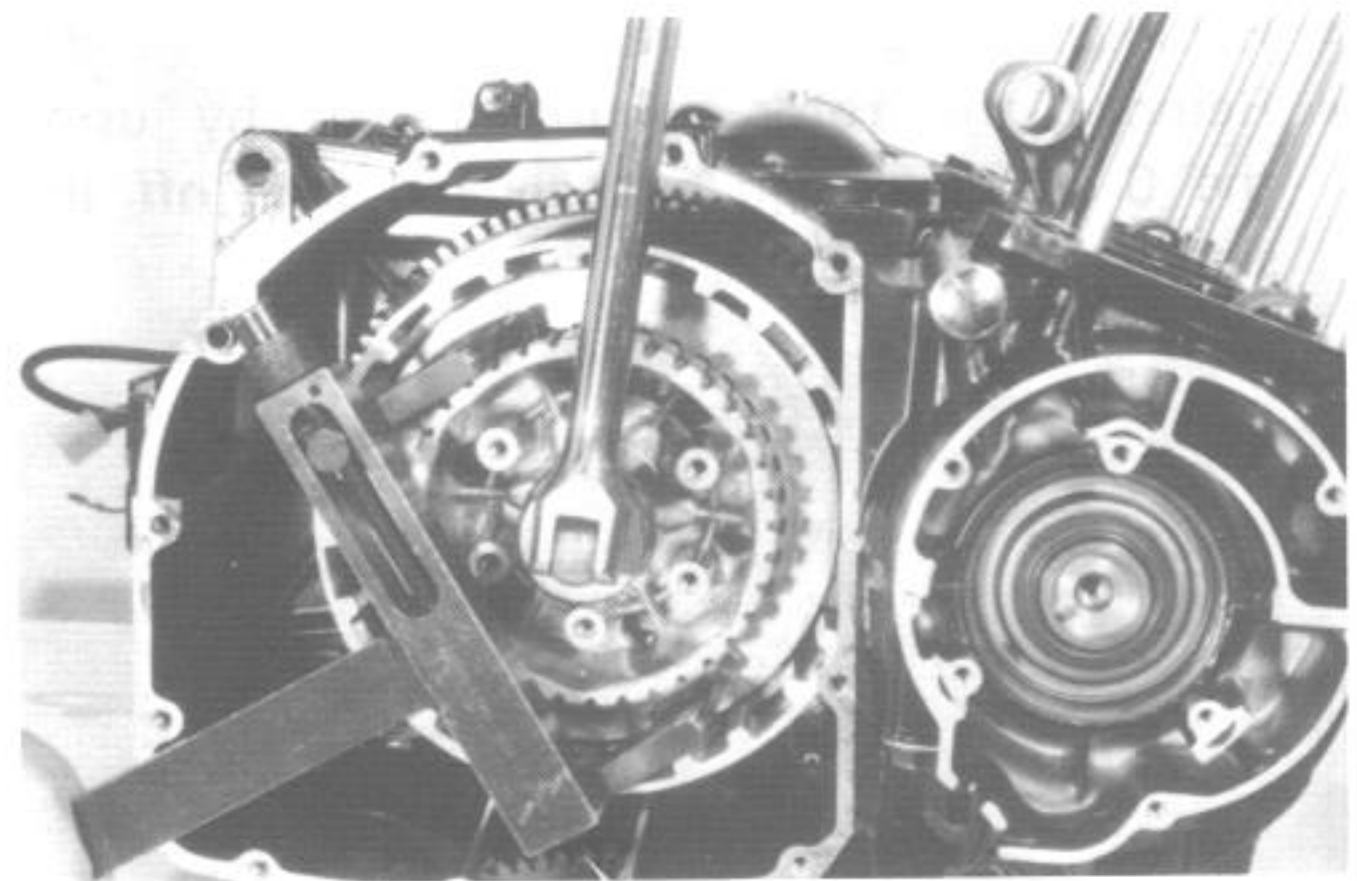

- Remove the thrust washer ①.
- Run two 6-mm bolts into the primary driven gear spacer to ease out the spacer by pulling. With the spacer removed, the primary driven gear (integral with the clutch housing) is free to disengage from the primary drive gear.

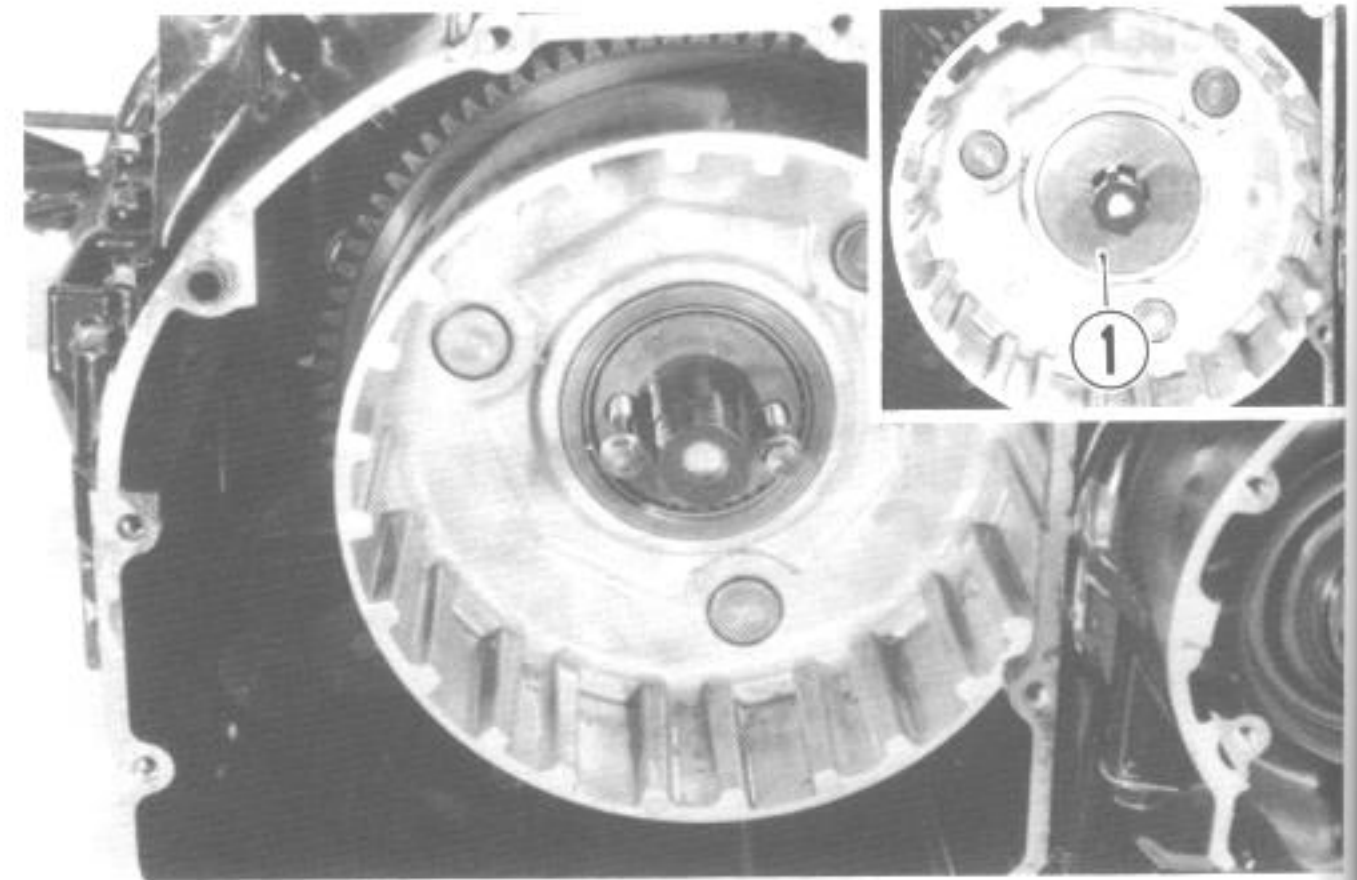

- Pull out the oil pump drive gear, its spacer and bearing.

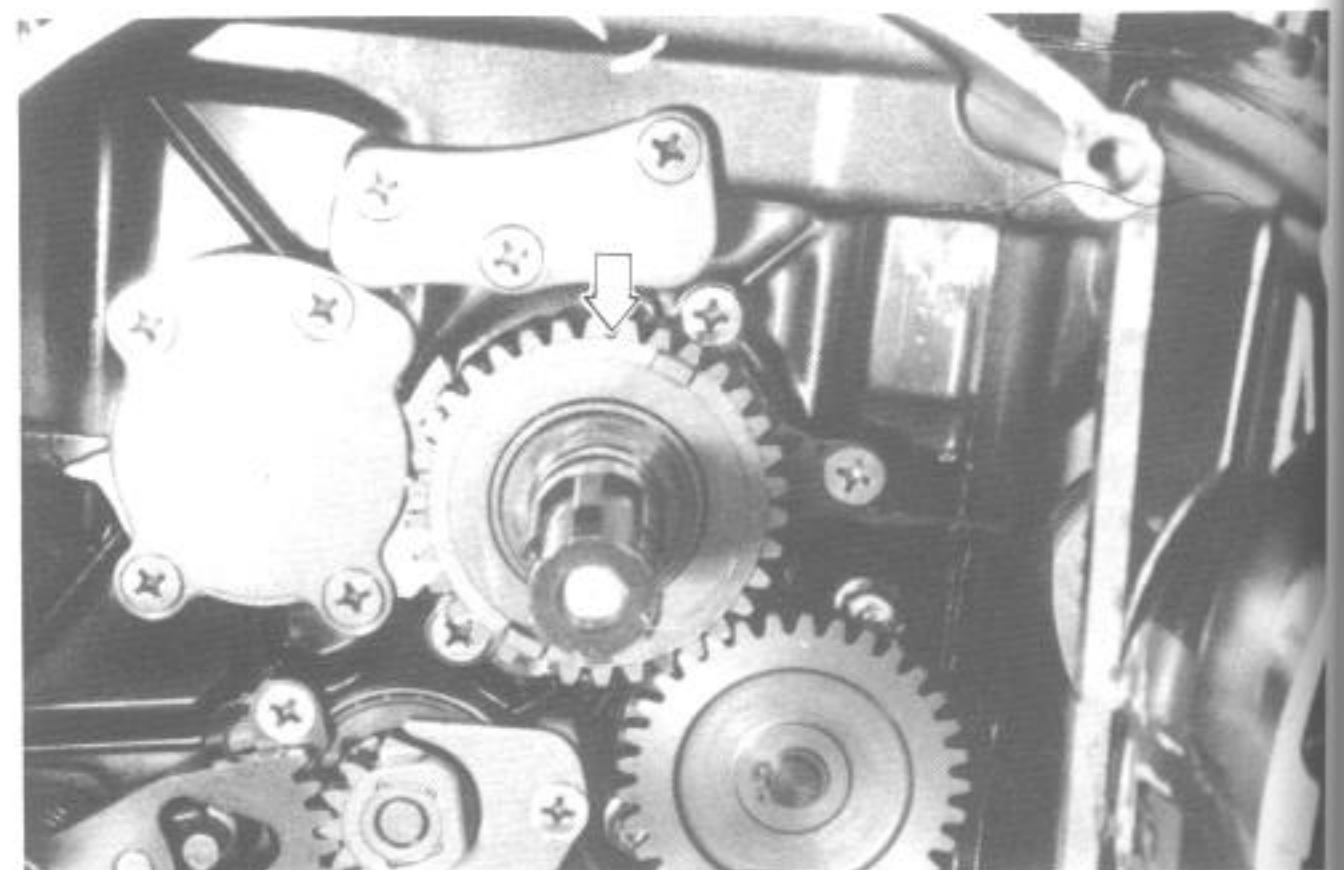

• Usi
driv

09

NO
Whe
the

• Rem

• Rem
shaft
• Extr

• Rem
coun

099

- Using circlip remover, remove the oil pump driven gear, its drive pin and washer.

09900-06107	Snapping pliers
-------------	-----------------

NOTE:
When removing the driven gear, do not lose the pin ①.

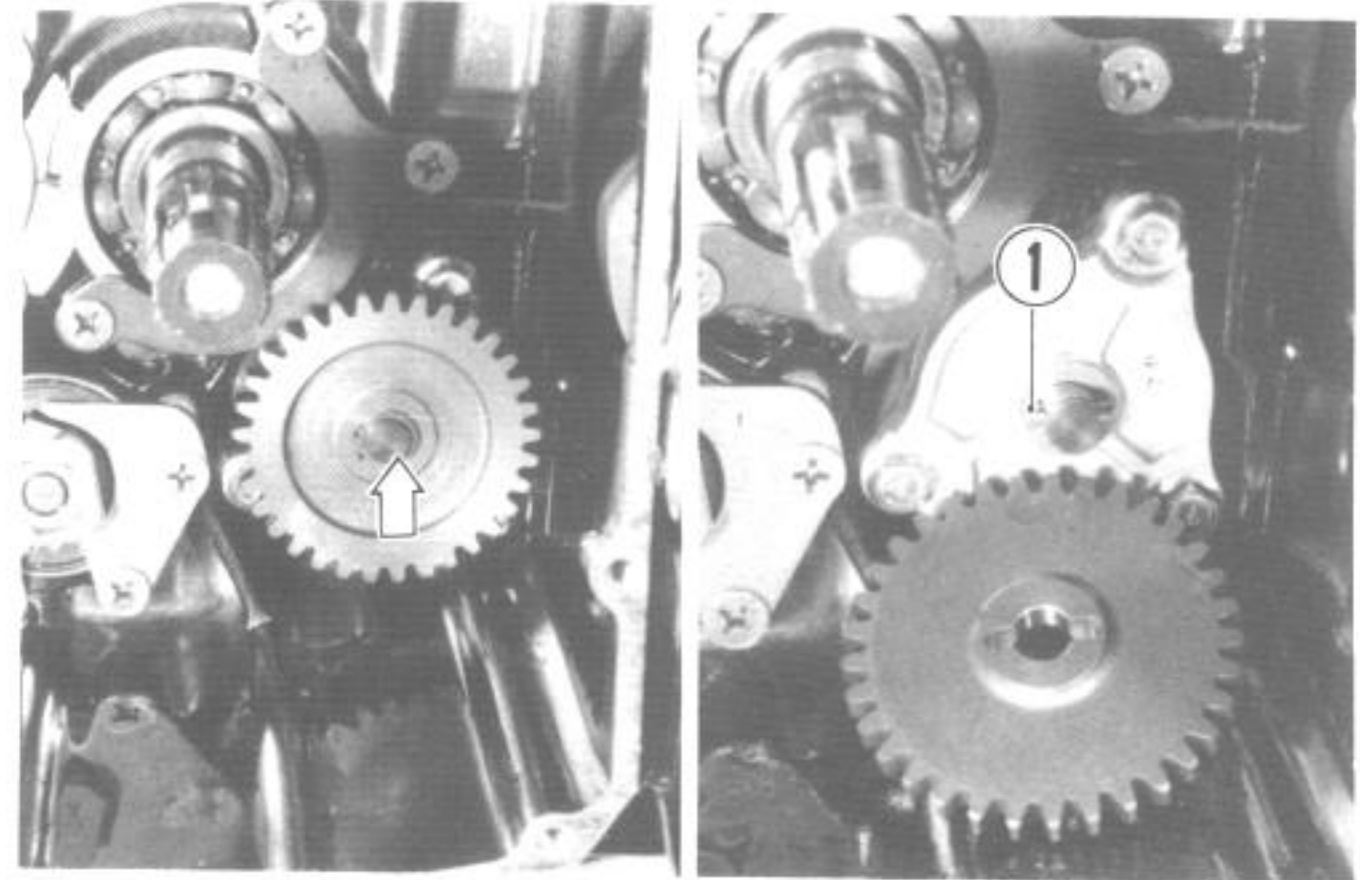

- Remove the oil pump with O-ring.

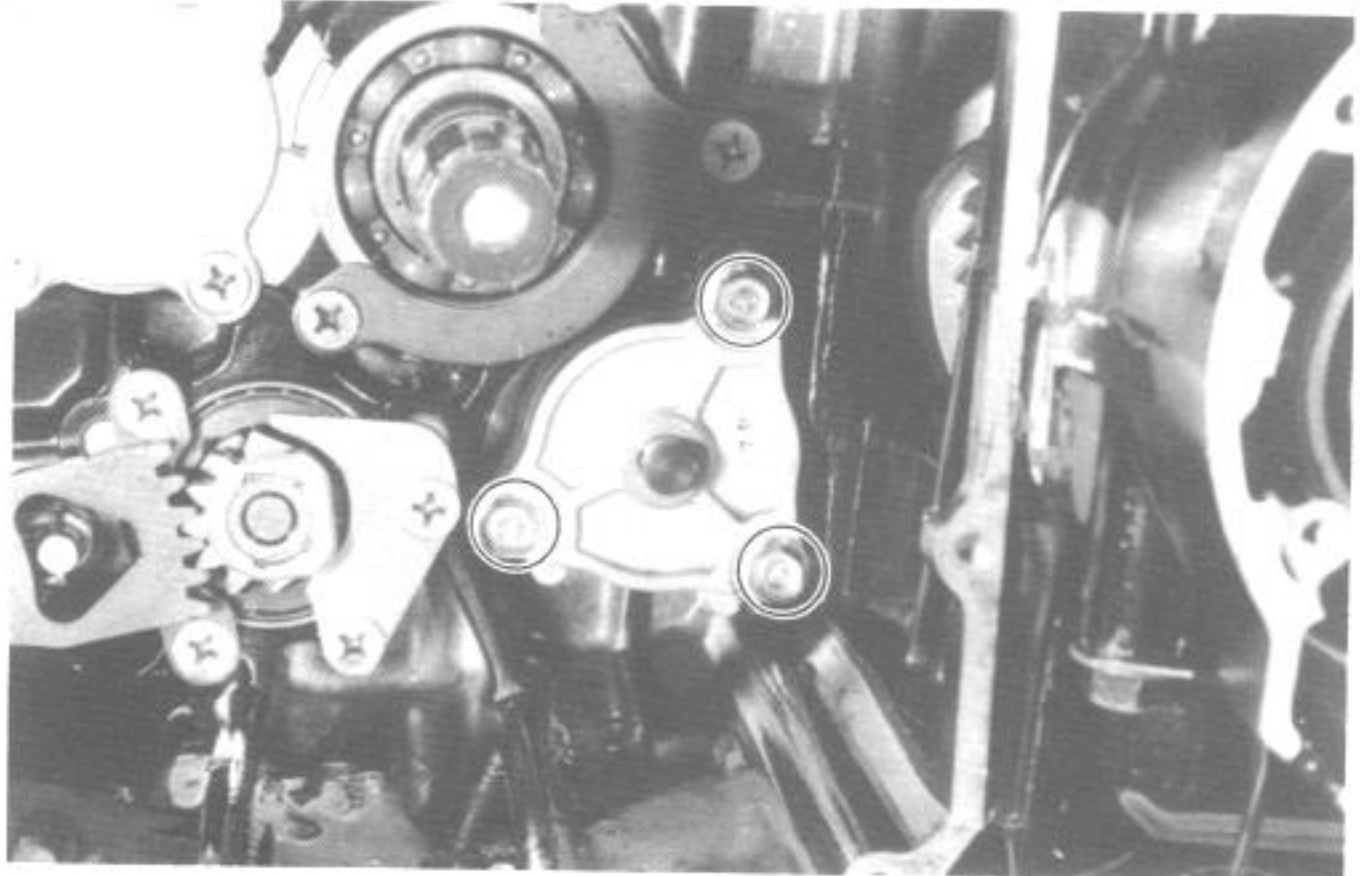

- Remove the clip and washer for gear shifting shaft stopper.
- Extract the gear shifting shaft.

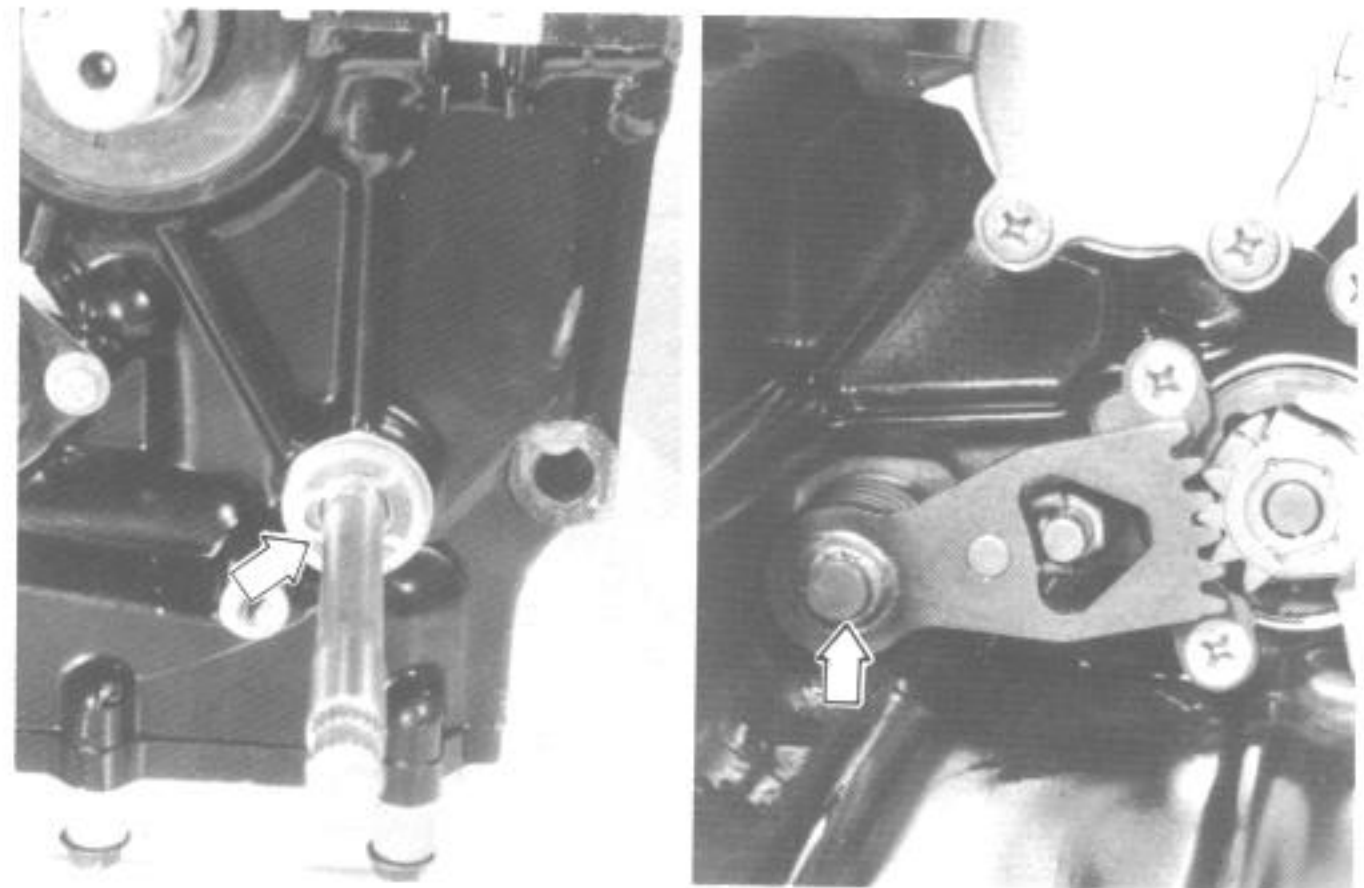

- Remove the drive shaft bearing holder ② and countershaft bearing retainer ③.

09900-09003	Impact driver set
-------------	-------------------

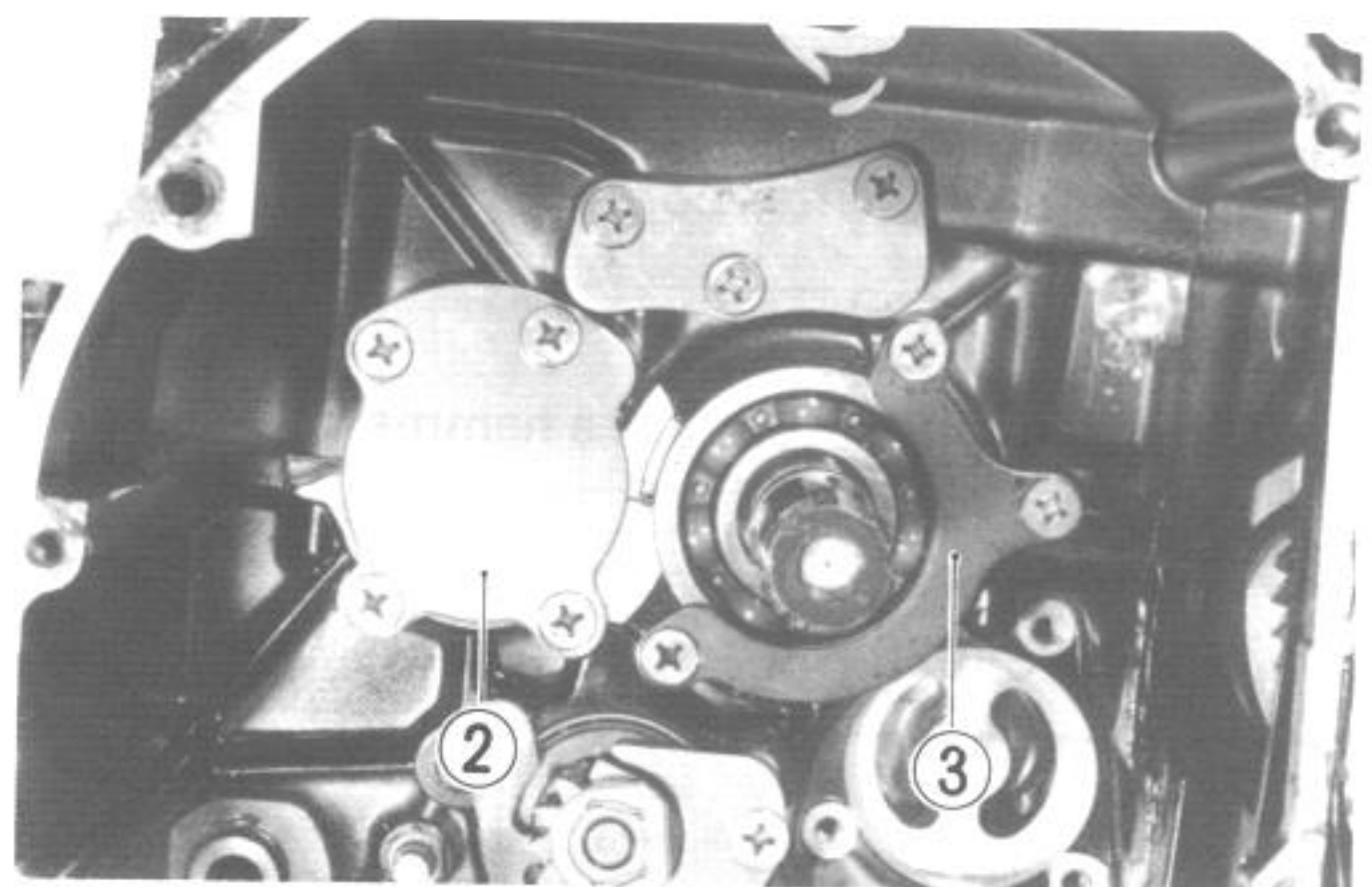

- Remove the generator cover and gasket.

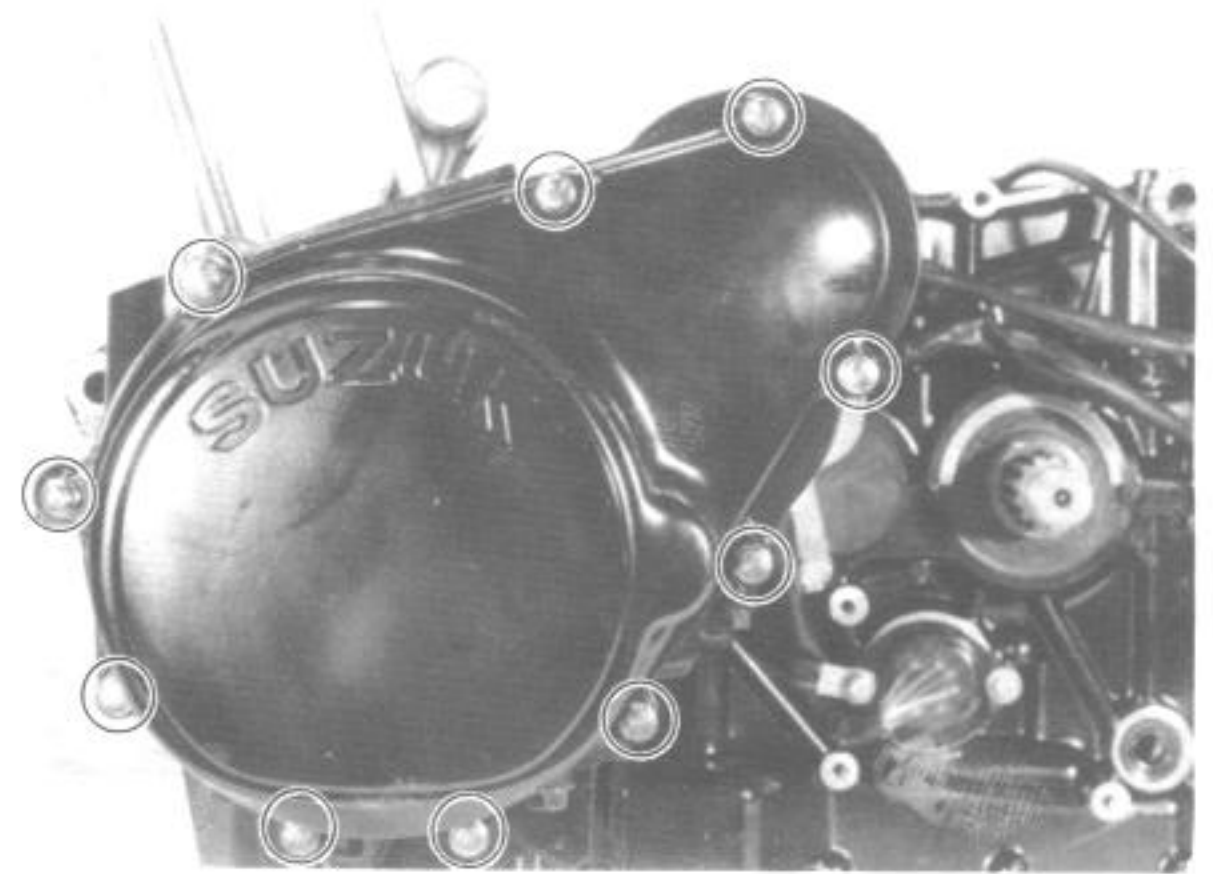

- Extract the starter motor idle gear shaft ① and remove the idle gear.

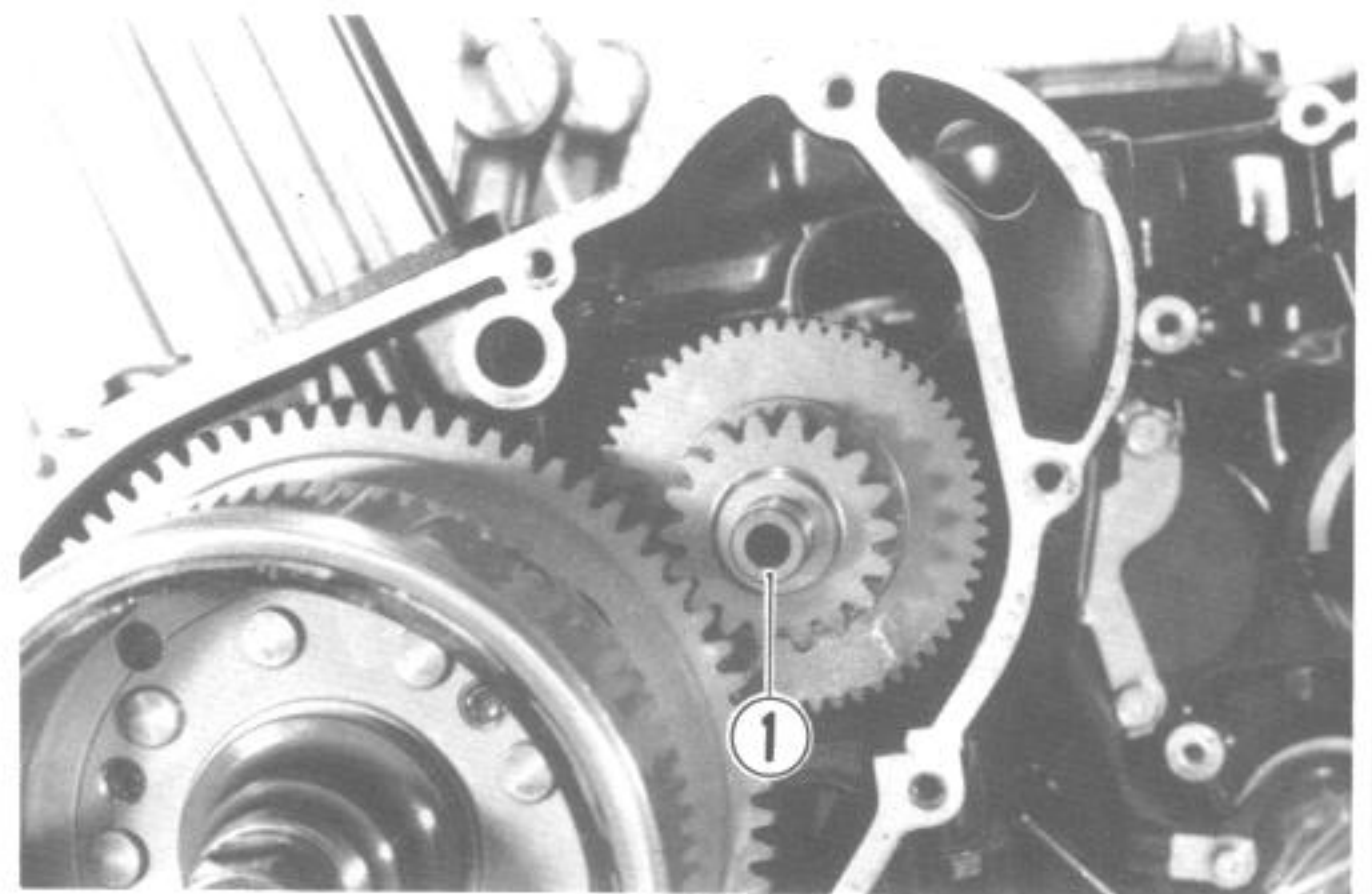

- Remove the rotor securing nut by using the special tool.

09930-44911	Rotor holder
-------------	--------------

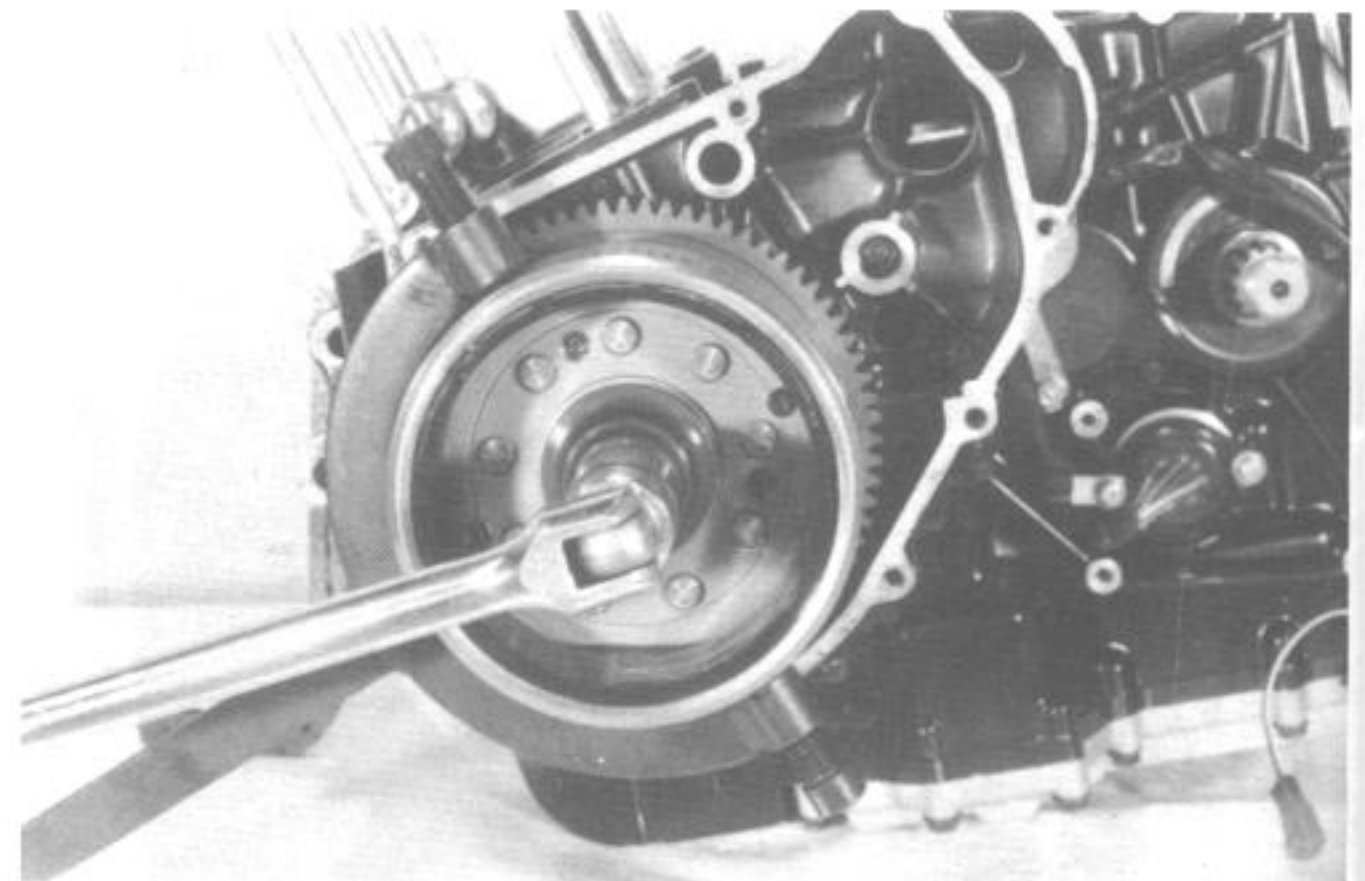

- Install rotor remover ② into the boss of rotor and remove rotor with starter clutch assembly by turning its center bolt ③.

NOTE:
Do not hit the rotor with a hammer.

09930-34930	Rotor remover
-------------	---------------

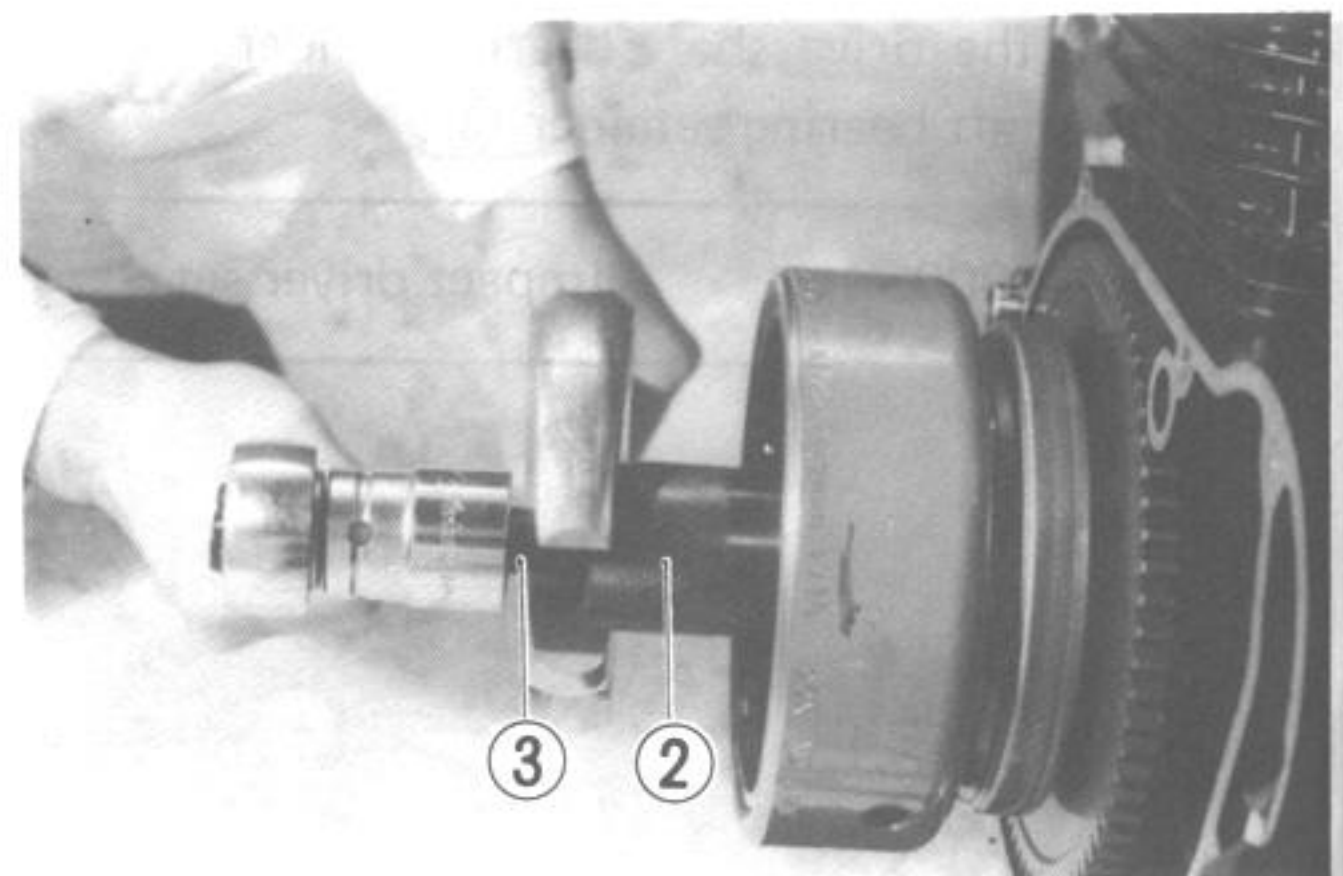

- Flatten the lock portion of countershaft oil seal retainer and extract two bolts ① to make lead wire free.
- Remove the oil seal retainer plate.
- Remove the crankcase securing nut ②.

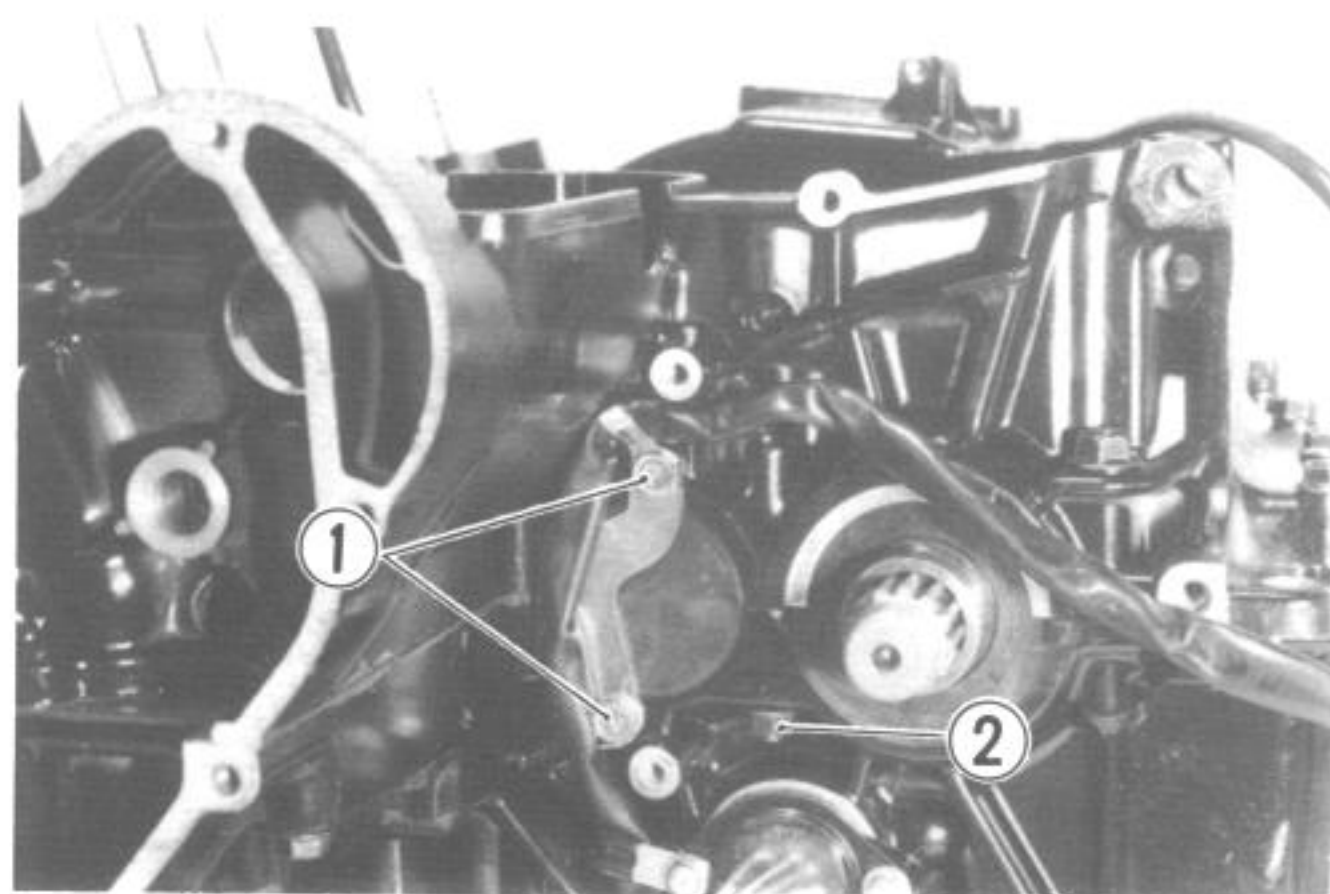

- Remove the crankcase securing bolts from upper crankcase.

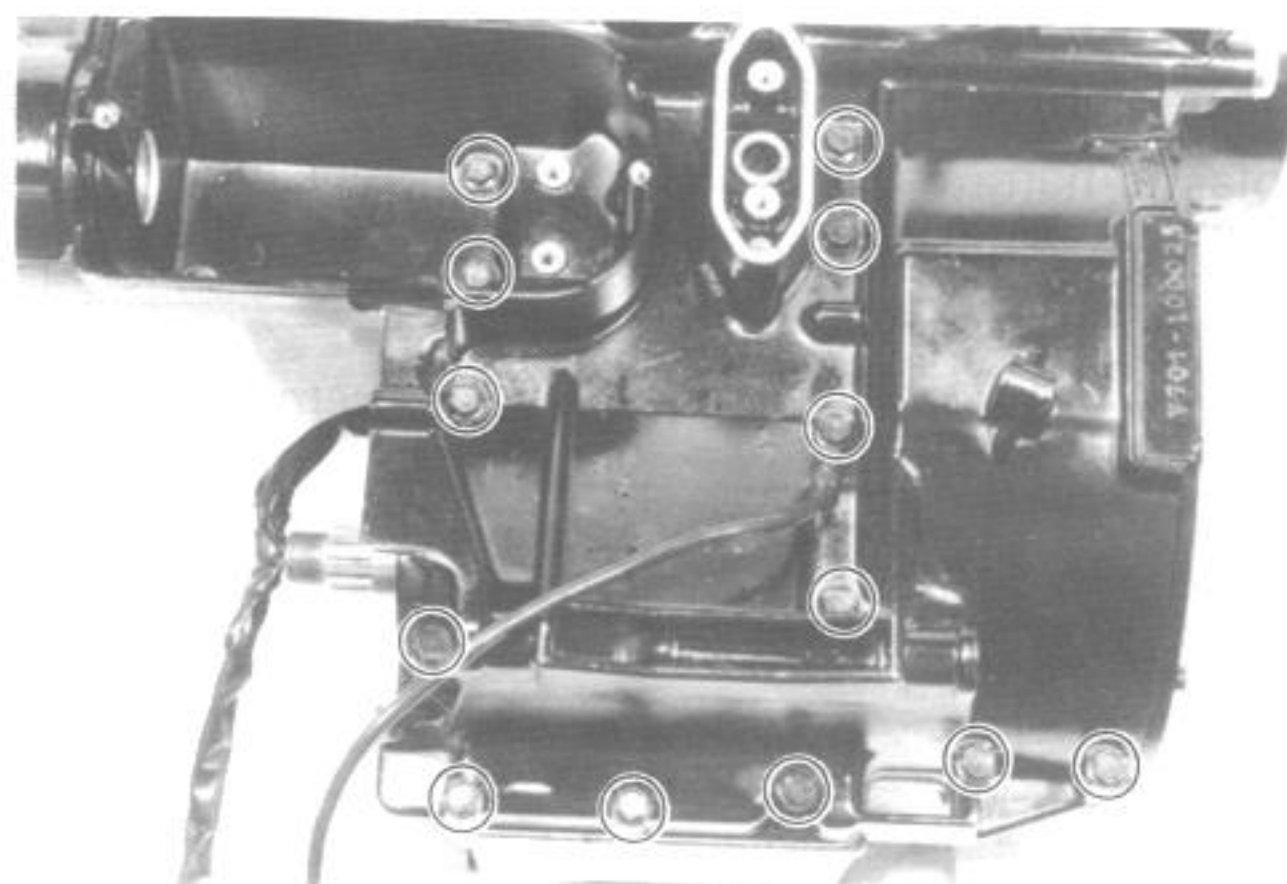

- Remove the oil filter cap and filter.

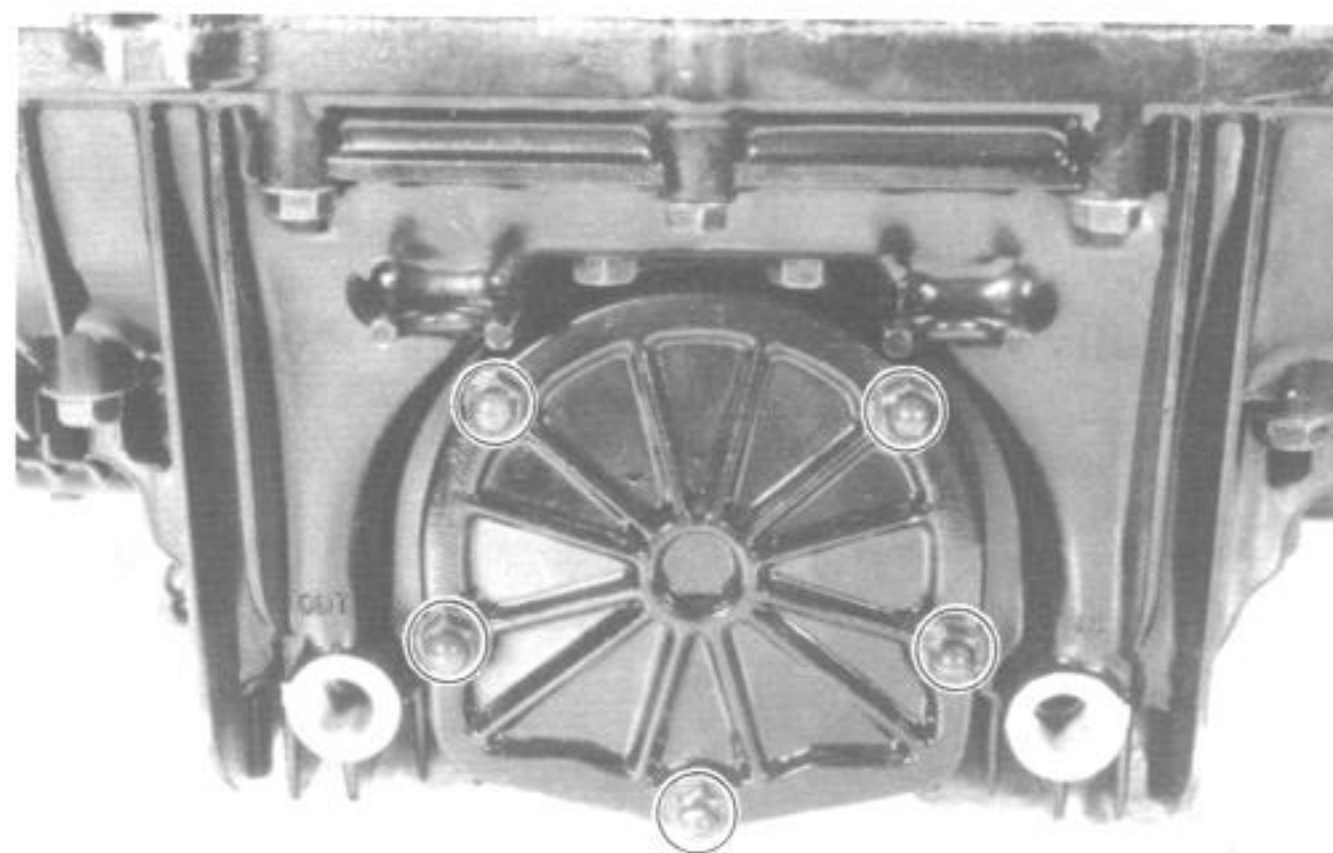

- Turn the engine up side down and remove the oil pan.
- Remove the oil sump filter.

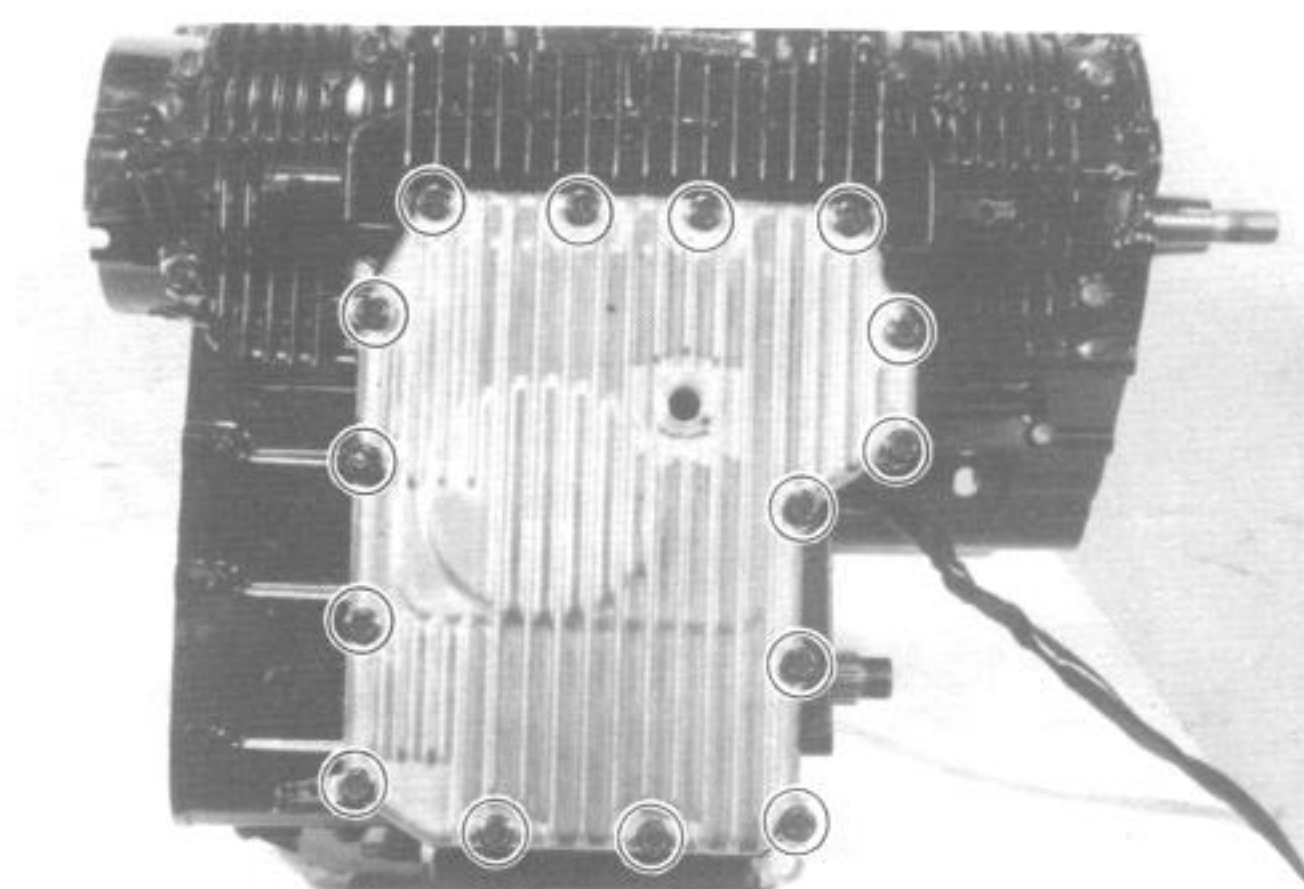

- When removing the lower crankcase tightening bolts, loosen them in the descending order of numbers assigned to these bolts.

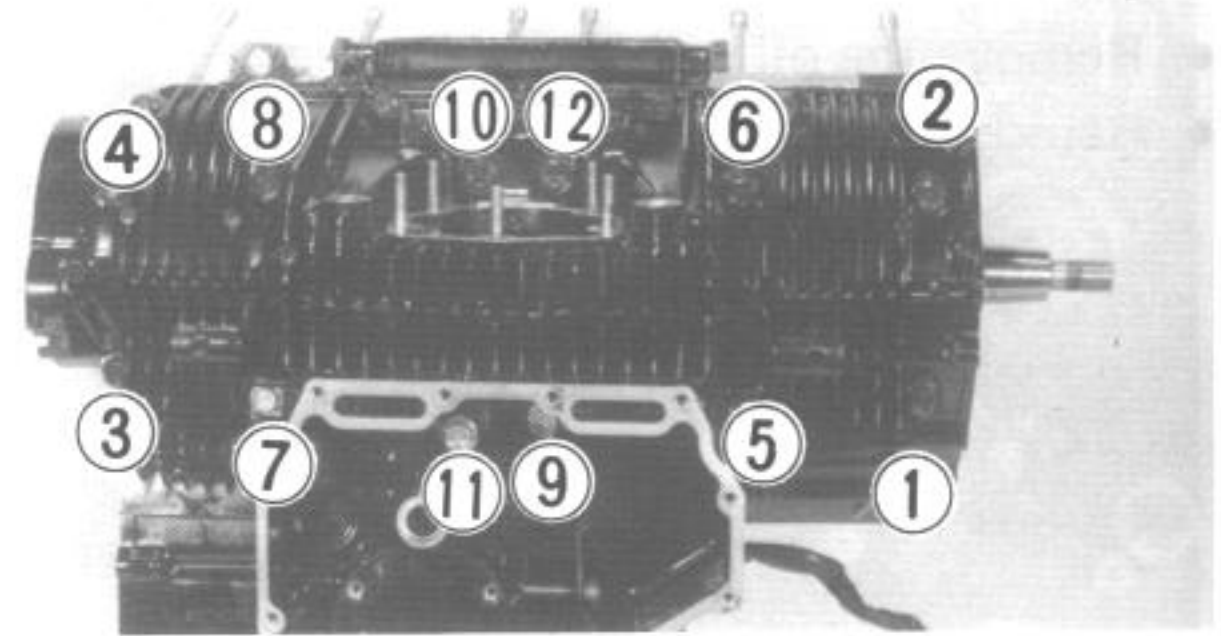

- Make sure that all bolts are removed.
- Tap lightly the lower crankcase side with a plastic hammer to separate the upper and lower crankcase halves and then lift the latter.

09912-34510	Crankcase disassembling tool
-------------	------------------------------

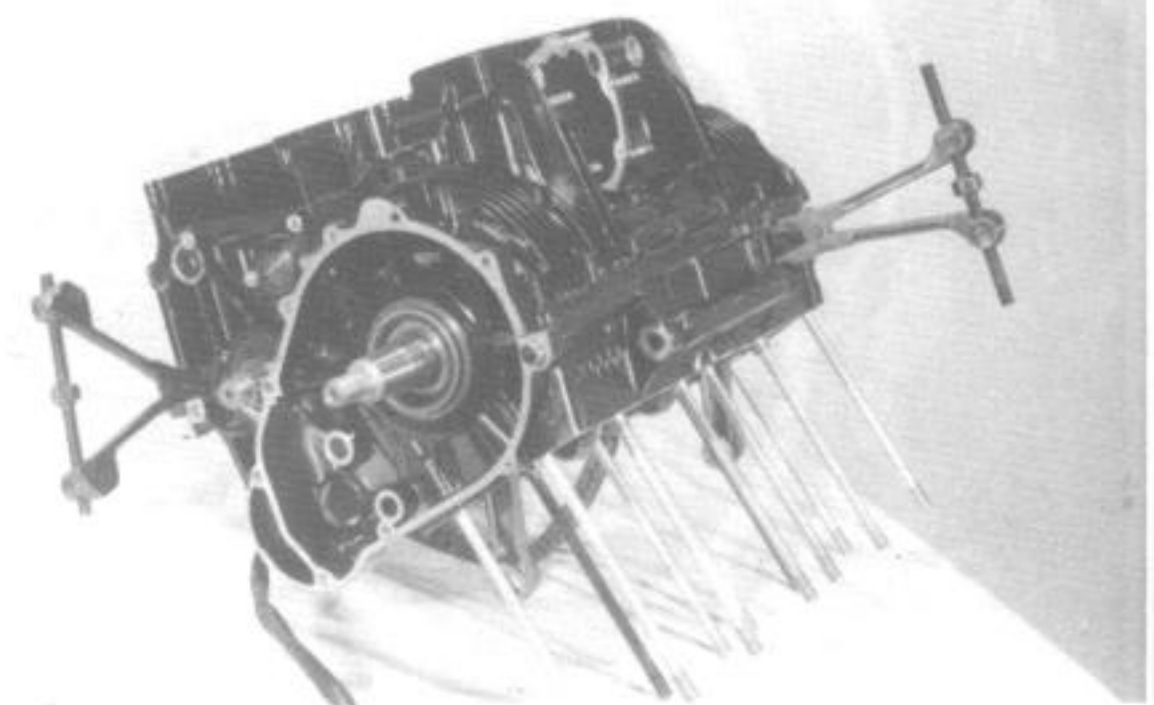

- Remove the crankshaft, countershaft and drive shaft.

NOTE:
Carefully set aside the six "C" rings.

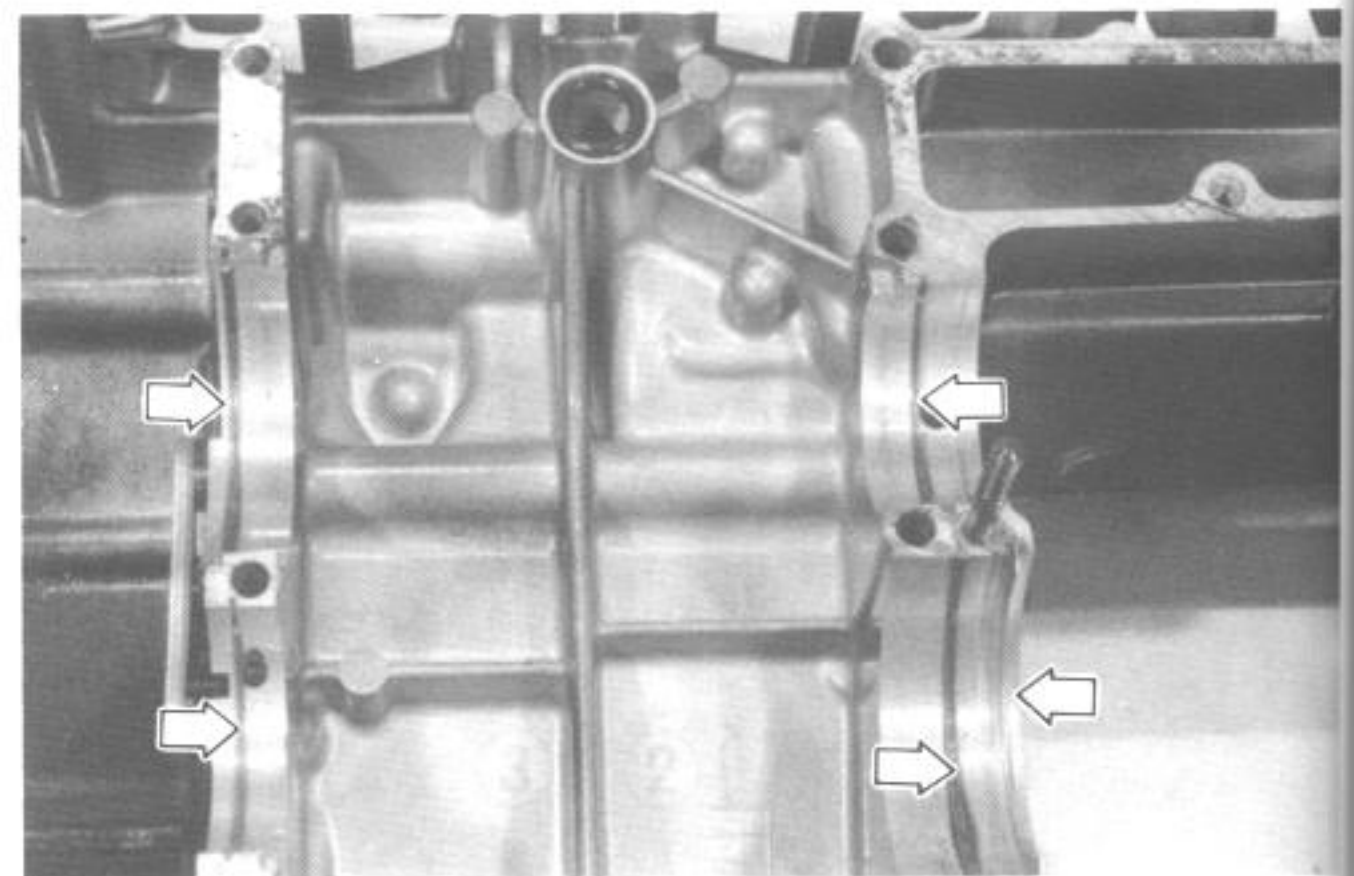
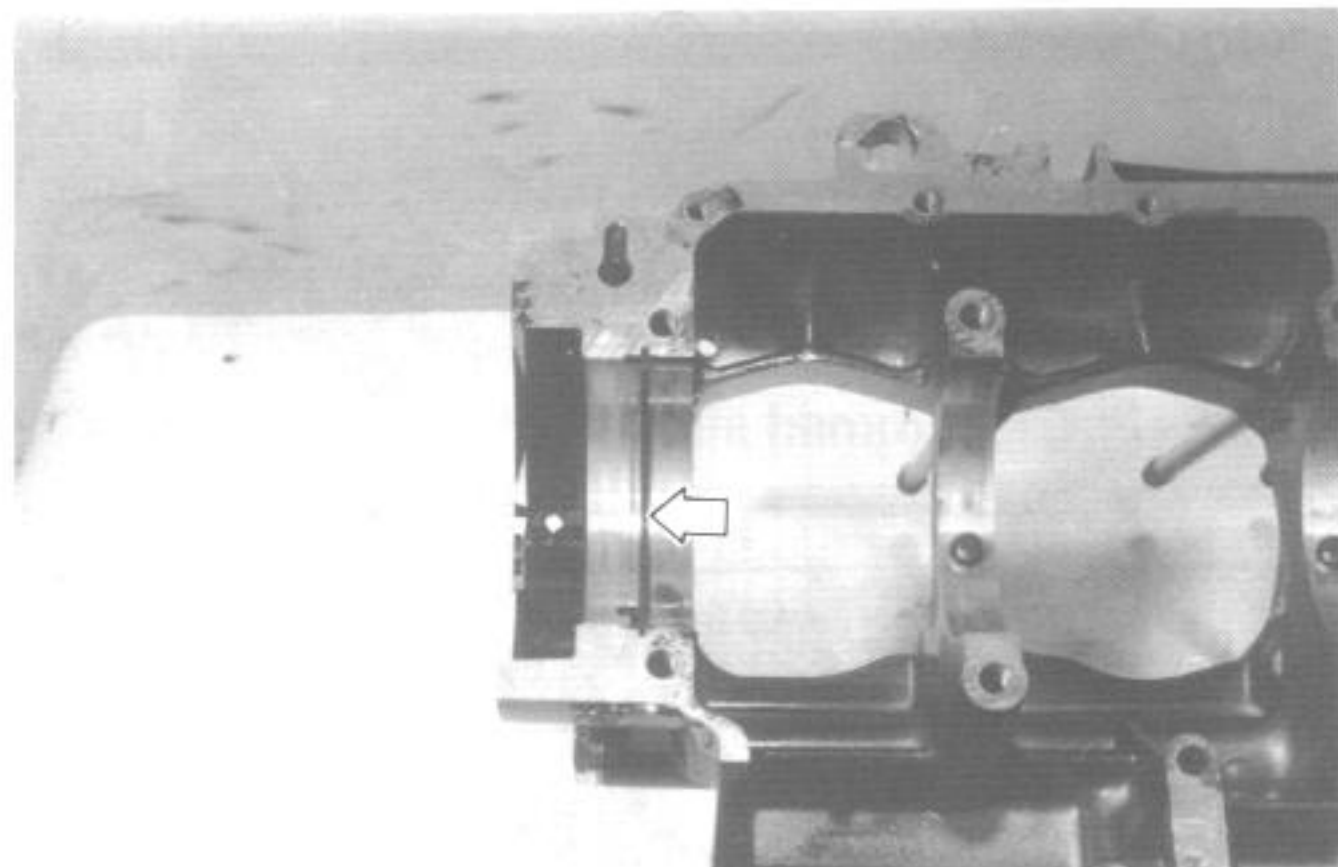
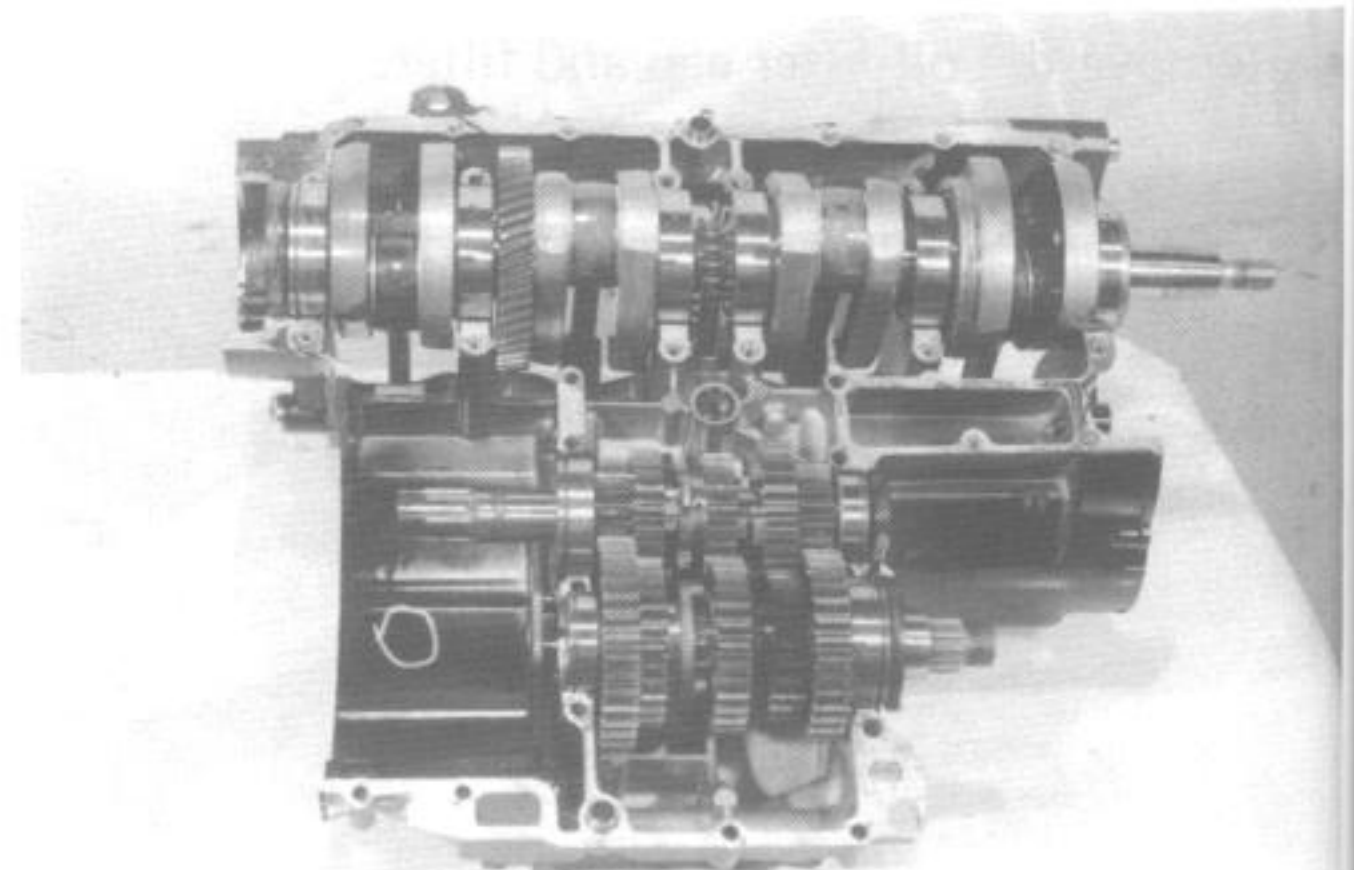

EN

- Remove the gear position indicator light switch ①.
- Remove the circlip from gearshift cam by using snapping pliers.

09900-06107

Snapping pliers

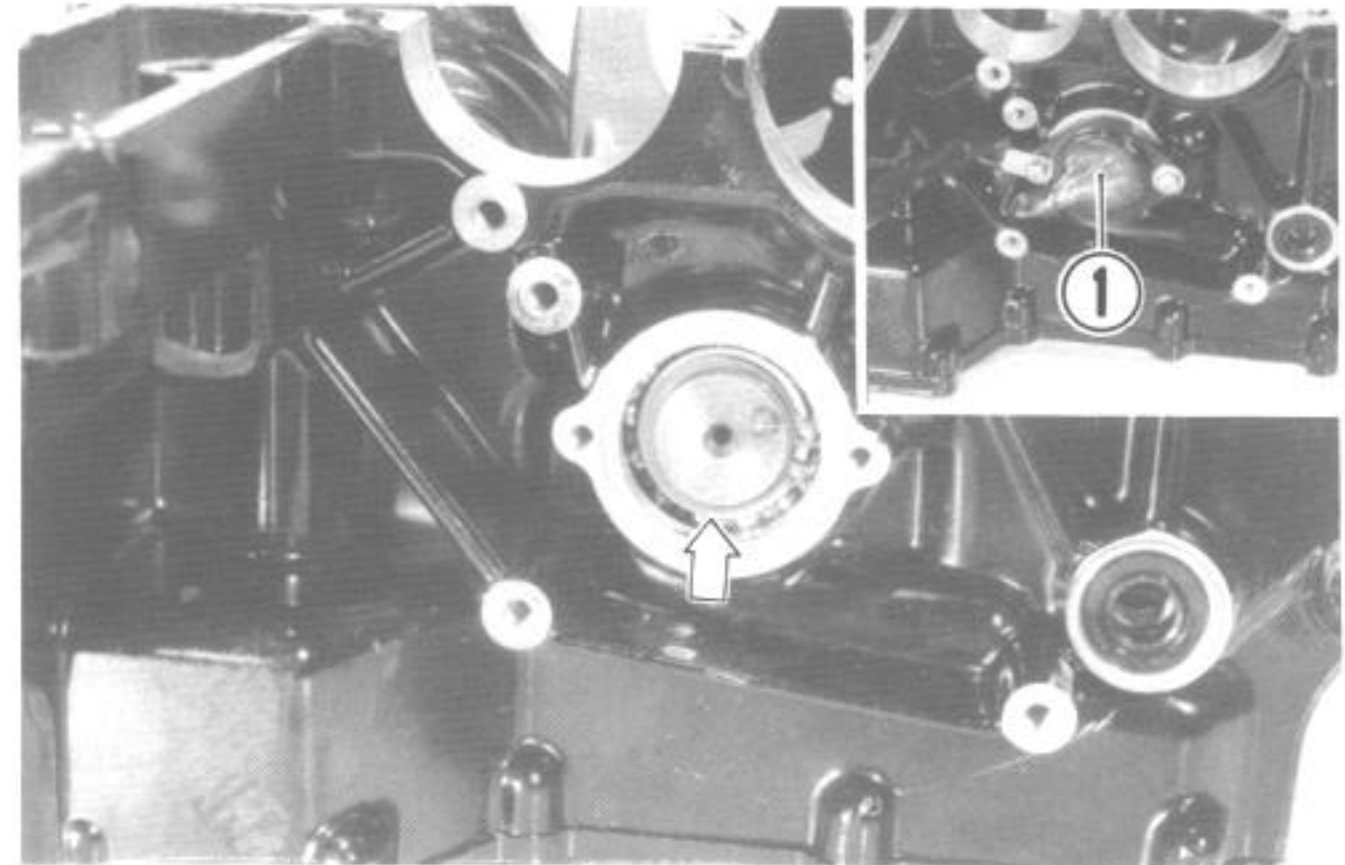

- Remove the gearshift cam guide and gearshift pawl screws ②.
- Hold the gear shifting forks and cam stopper by hand to extract two gear shifting fork shafts from the lower crankcase.

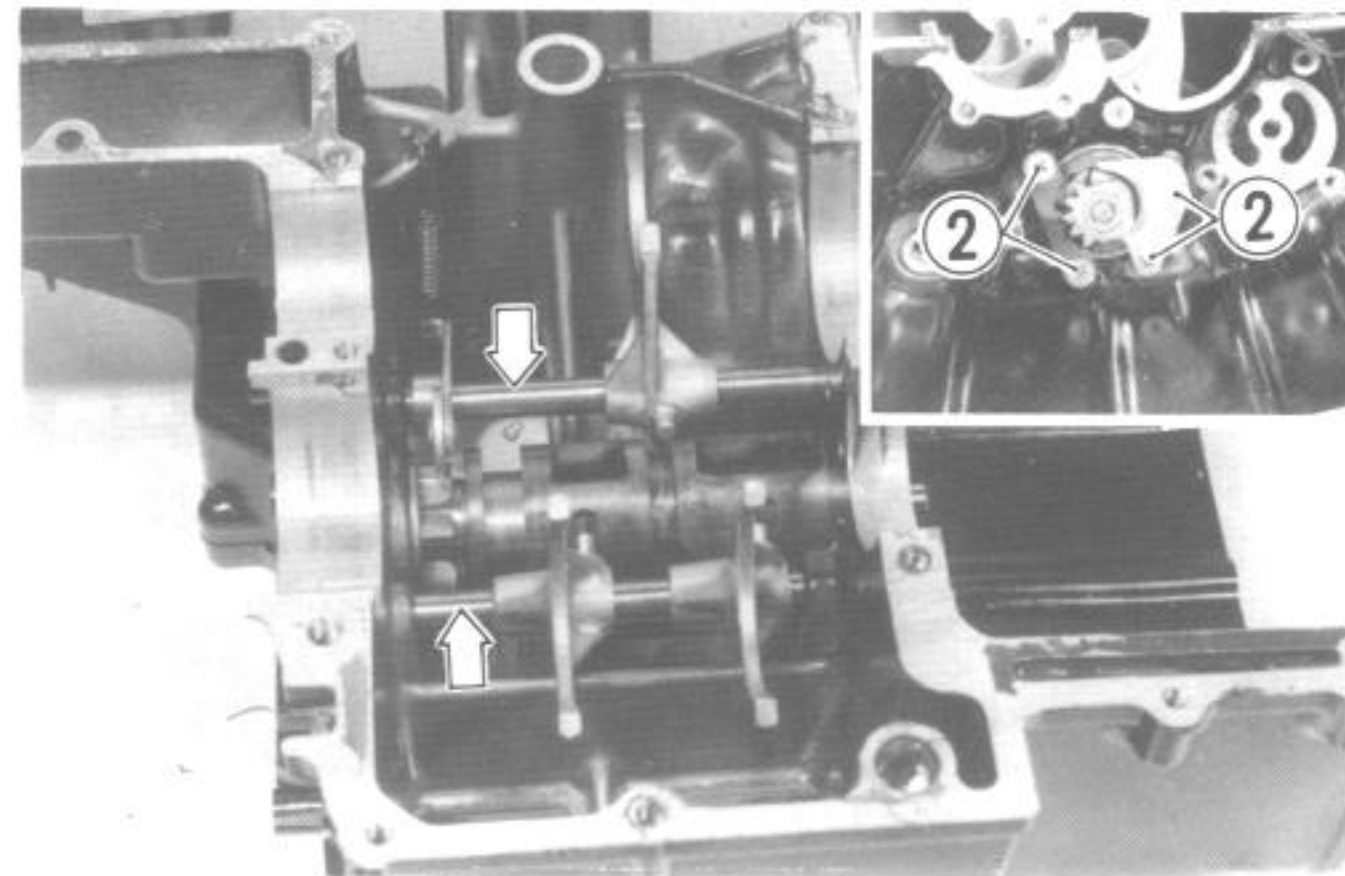

- Remove the neutral cam stopper holder to remove cam stopper and spring.

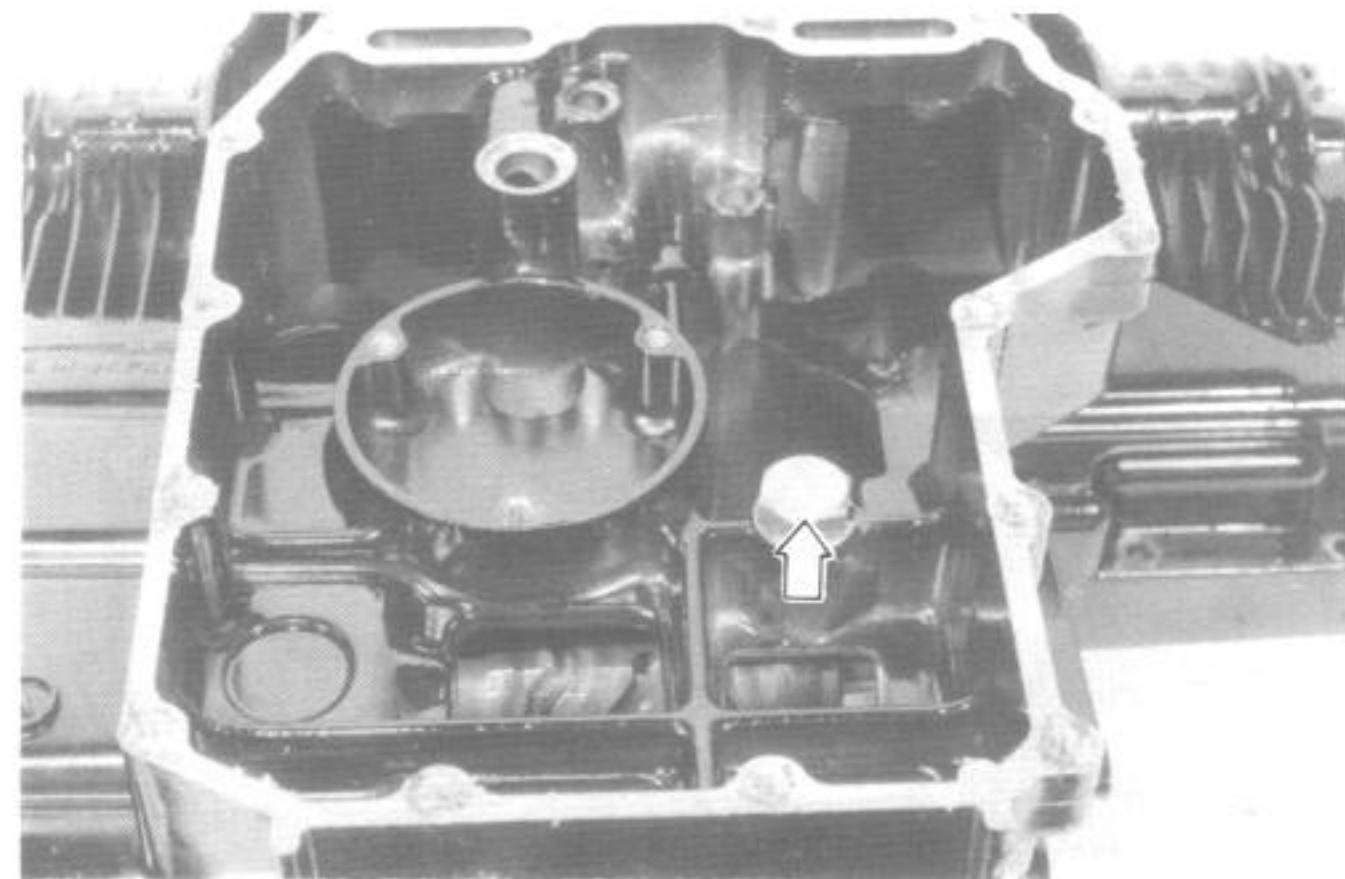

- Extract the gearshift cam from the lower crankcase.

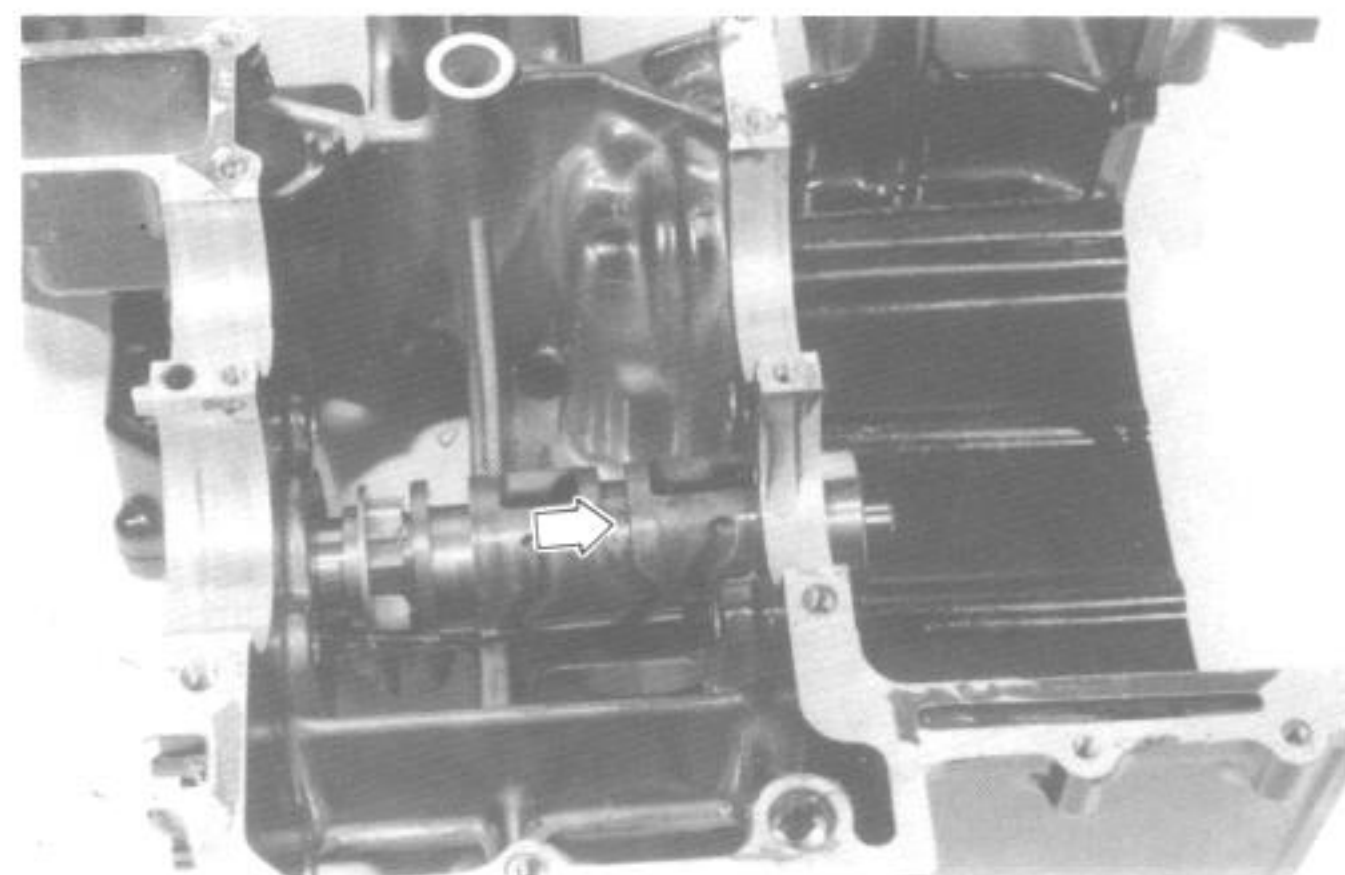

- Remove the bearing stopper circlip by using the special tool.

09900-06105	Snapping pliers
-------------	-----------------

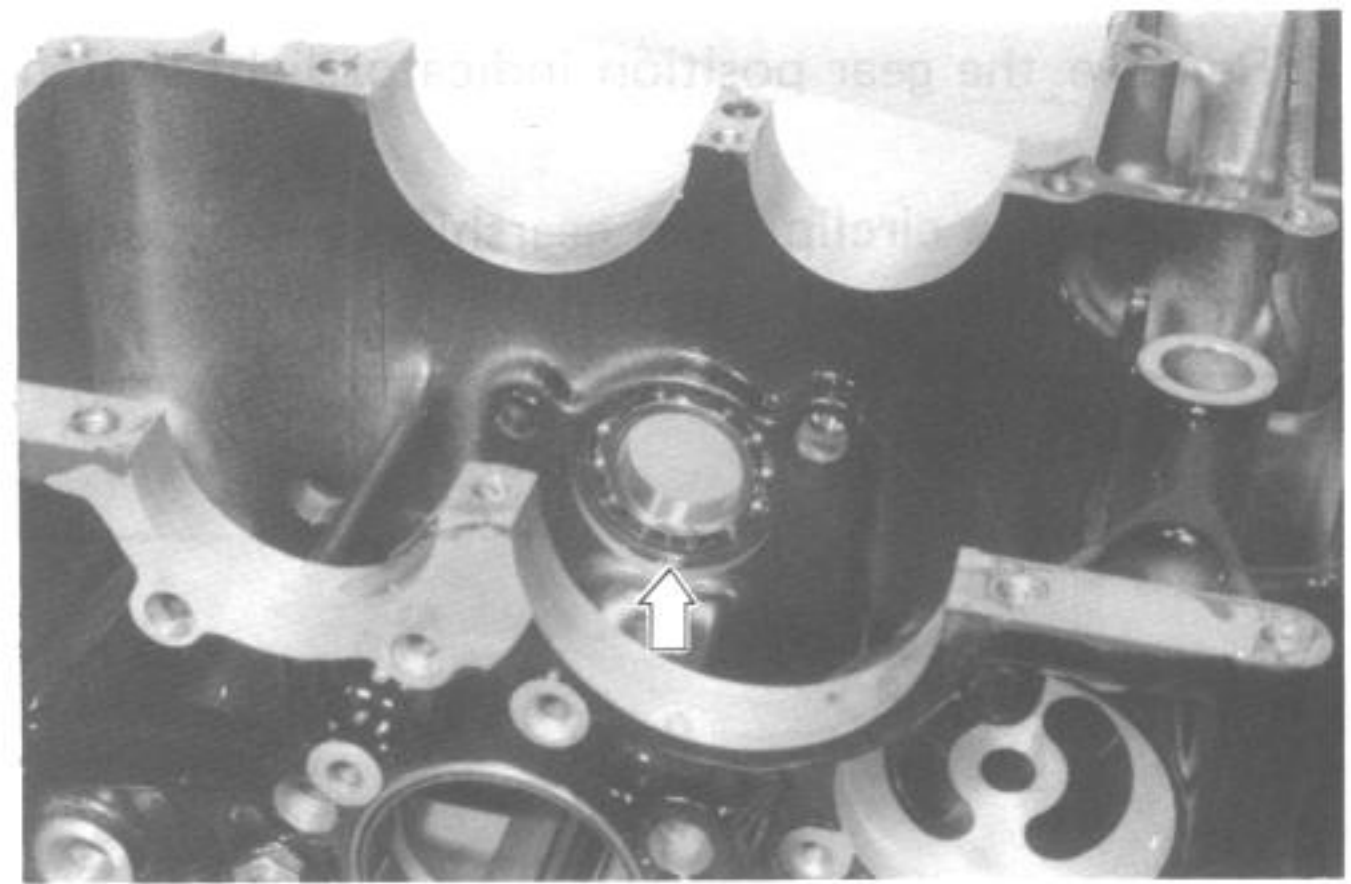

- Using the bearing remover, extract cam bearing as shown.

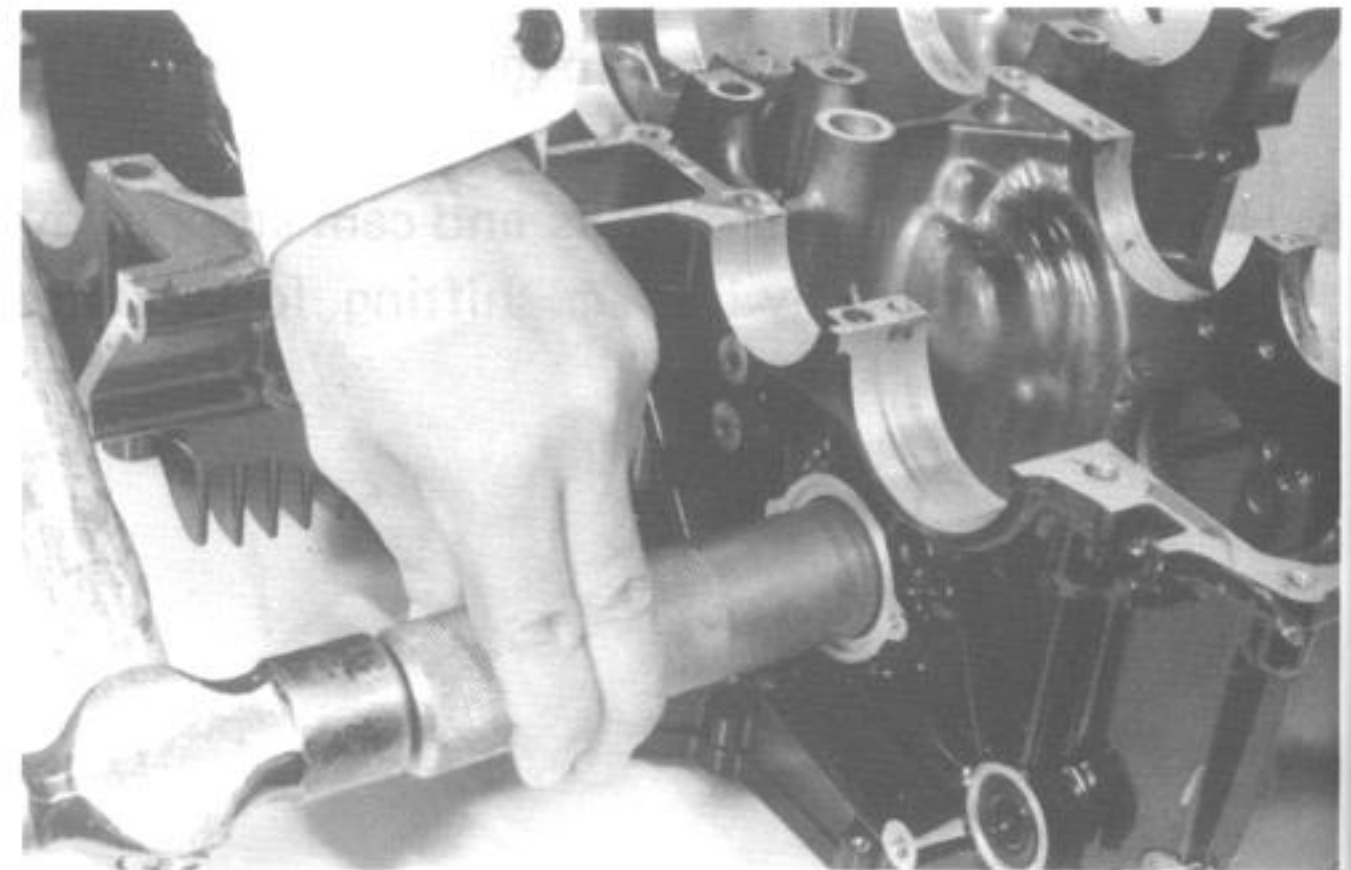

- Remove the cam chain guide holder ① and oil separator plates ②.

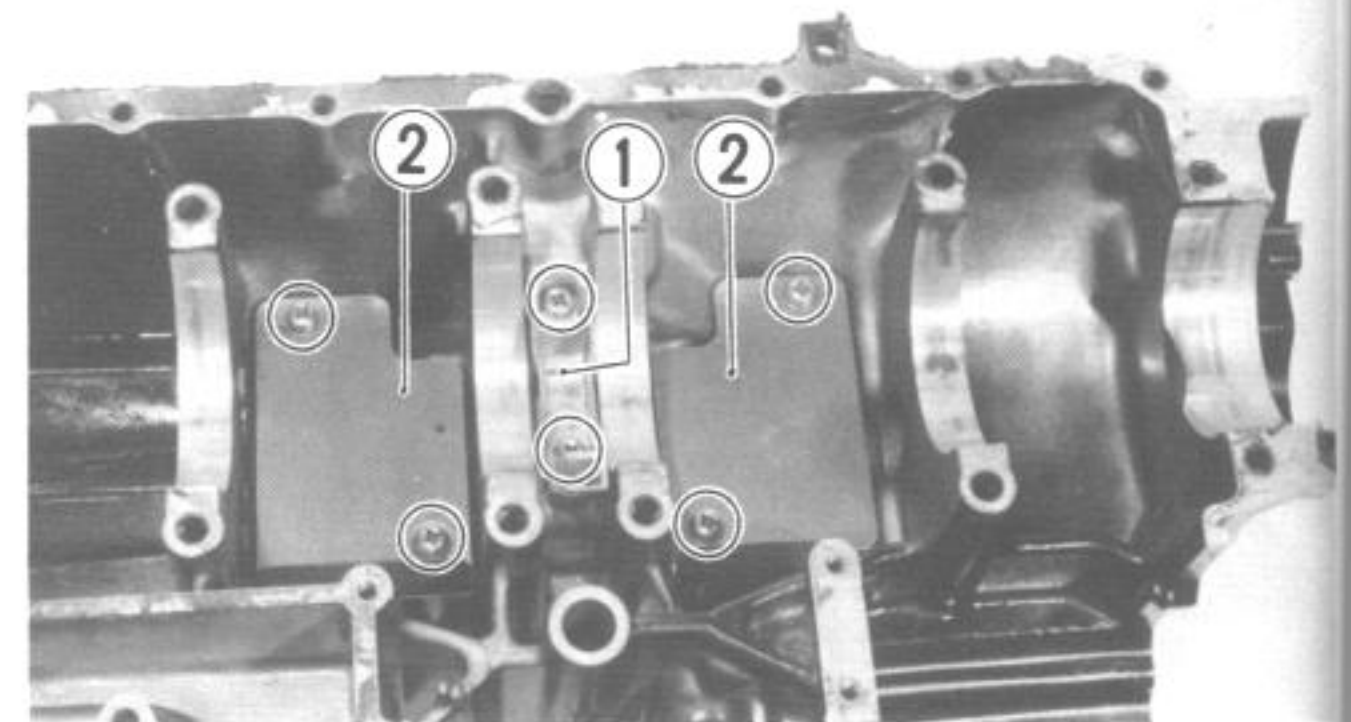

ENG
CYL
CA
Be
its
de
"In
res
asse
NO
* W
th
b
ro
* R
as
be
sp
sh
• Usin
the v
099
099
• Take
valve
099
099
• Take
and c
• From
In
Ext

ENGINE COMPONENTS INSPECTION AND SERVICING

CYLINDER HEAD SERVICING

CAUTION:

Be sure to identify each removed part as to its location, and lay the parts out in groups designated as "No. 1", "No. 2", "Exhaust", "Inlet", "R" and "L", so that each will be restored to the original location during assembly.

NOTE:

- * When removing rocker arm shaft, remove the rocker arm shaft stop bolts ① and bolts ②, and screw 6 mm bolt into the rocker arm shaft end and pull it out.
- * Removal of valves completes ordinary disassembling work. If valve guides have to be removed for replacement after inspecting related parts, carry out the steps shown in valve guide servicing.

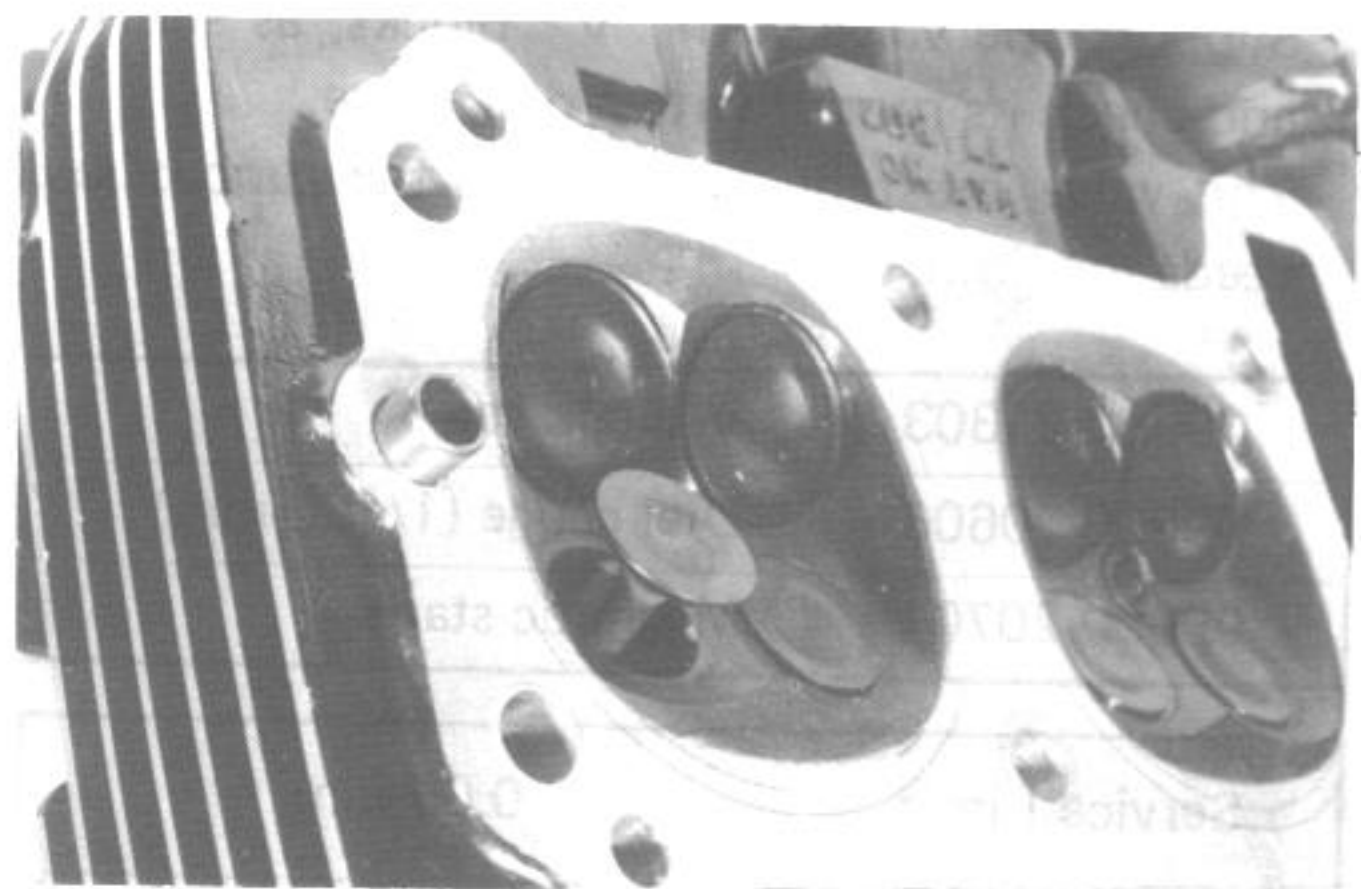
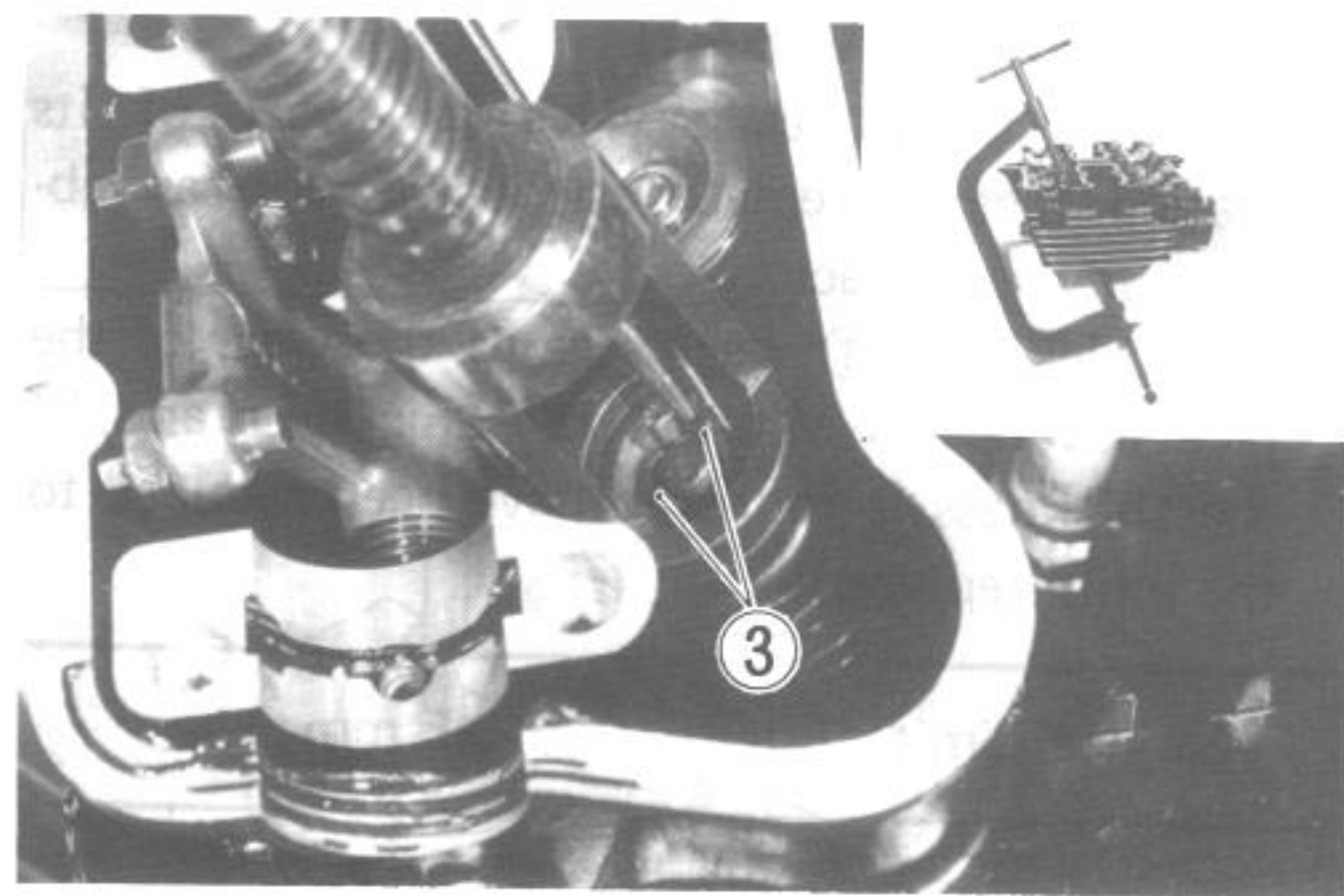
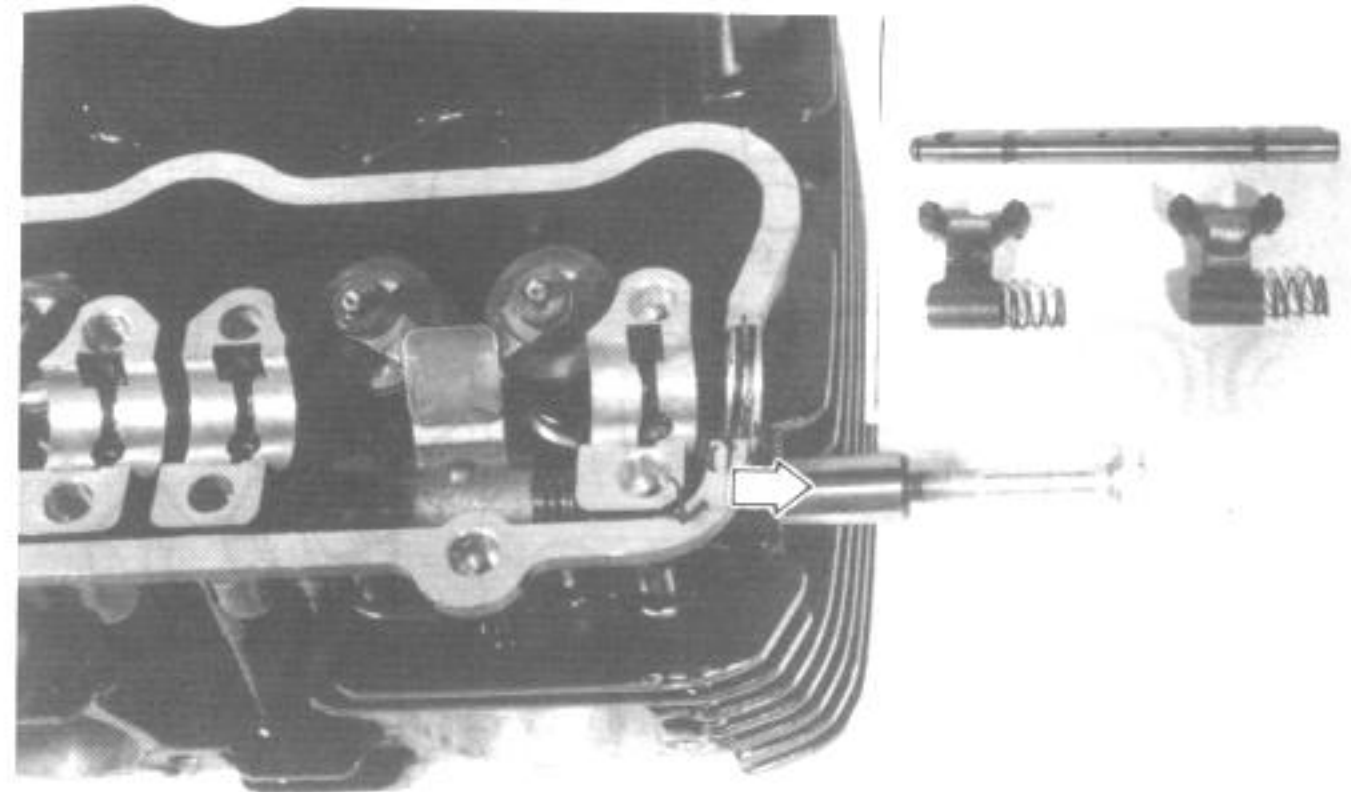
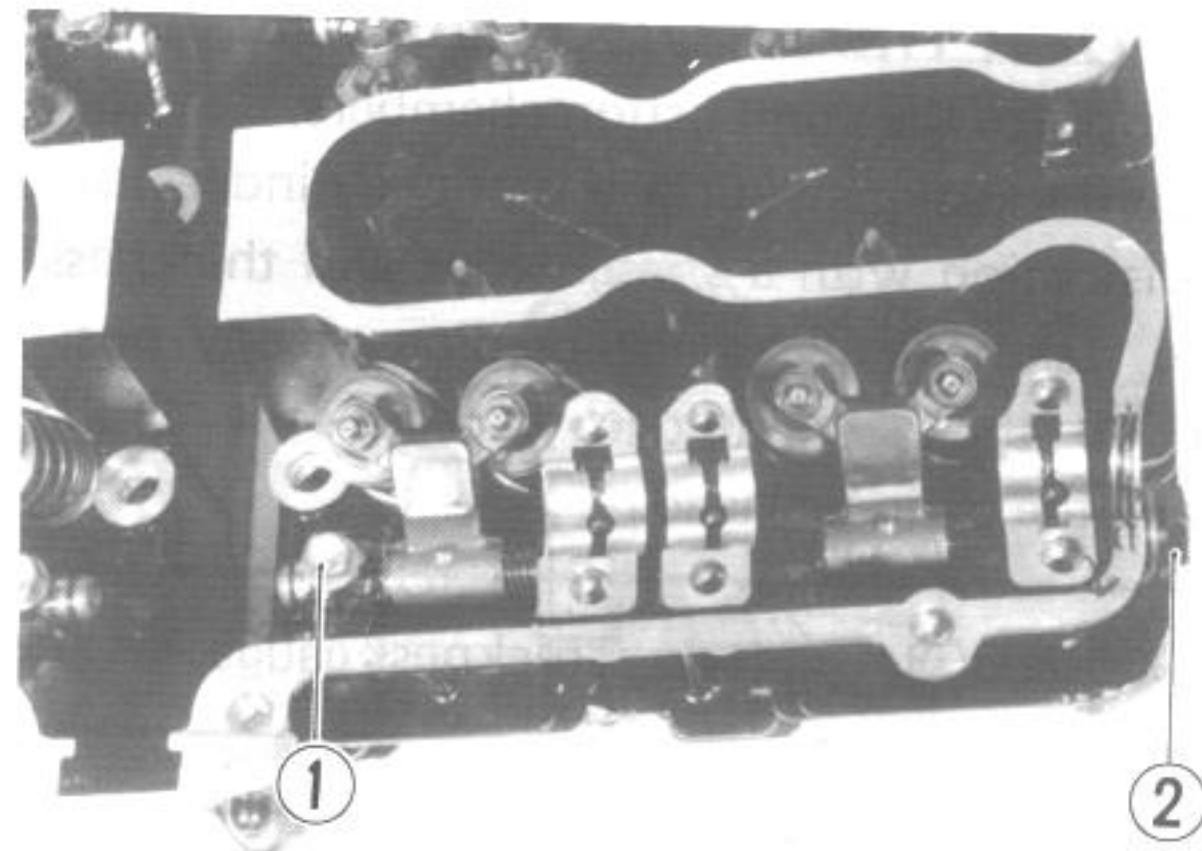

Inlet

- Using valve lifter and its attachment, compress the valve springs.

09916-14510	Valve lifter
09916-14910	Valve lifter attachment

- Take off the two cotter halves ③ from the valve stem by using the special tool.

09916-84510	Tweezers
-------------	----------

09900-2

- Take out the valve spring retainer, inner spring and outer spring.
- From the other side, pull out the valve.

Inlet Valve

Exhaust Valve



CYLINDER HEAD DISTORTION

- Decarbonize the combustion chambers.
- Check the gasketed surface of the cylinder head for distortion with a straightedge and thickness gauge, taking a clearance reading at any position of the straightedge exceeds the limit, replace the cylinder head.

09900-20803	Thickness gauge
-------------	-----------------

Service Limit	0.20 mm
---------------	---------

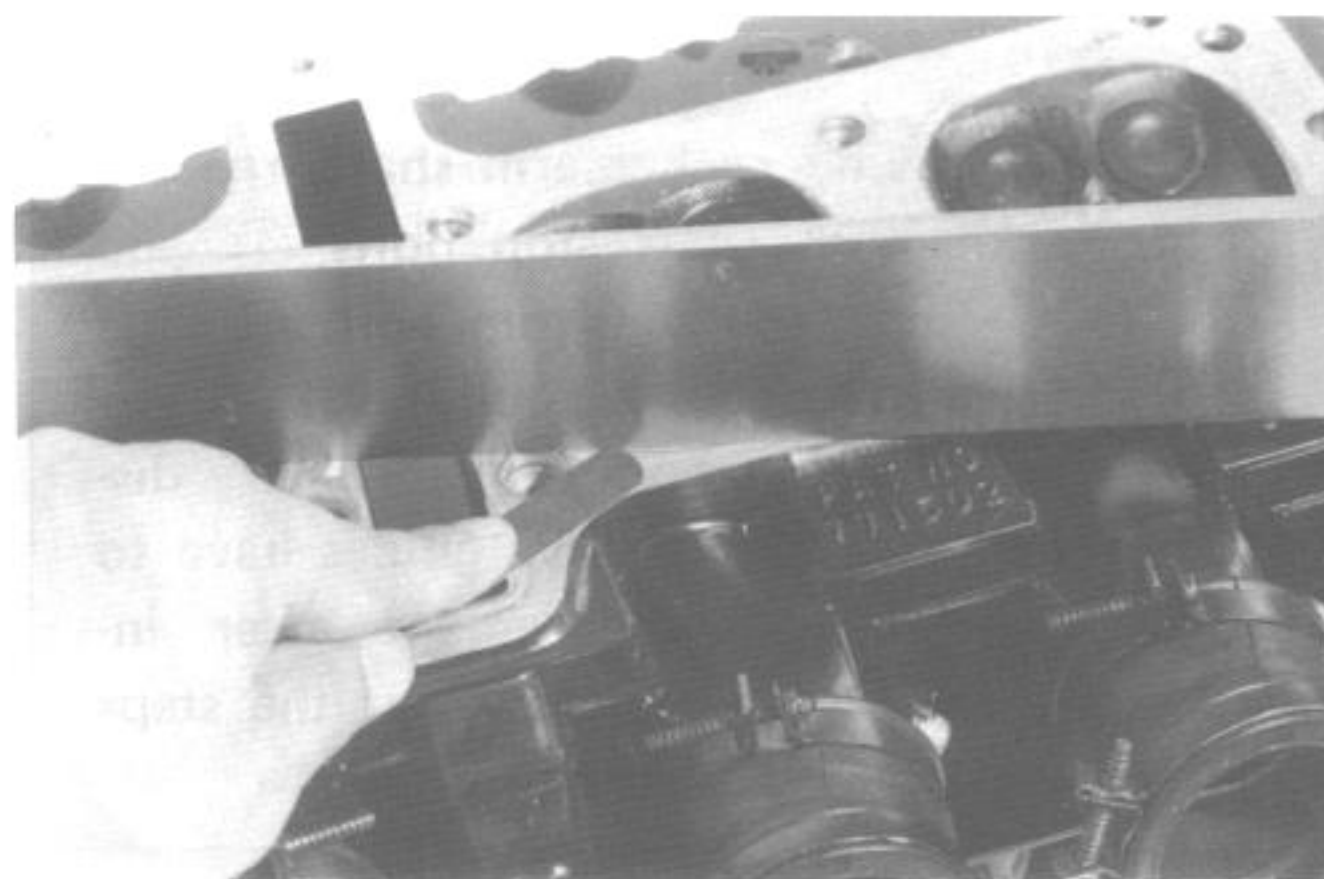
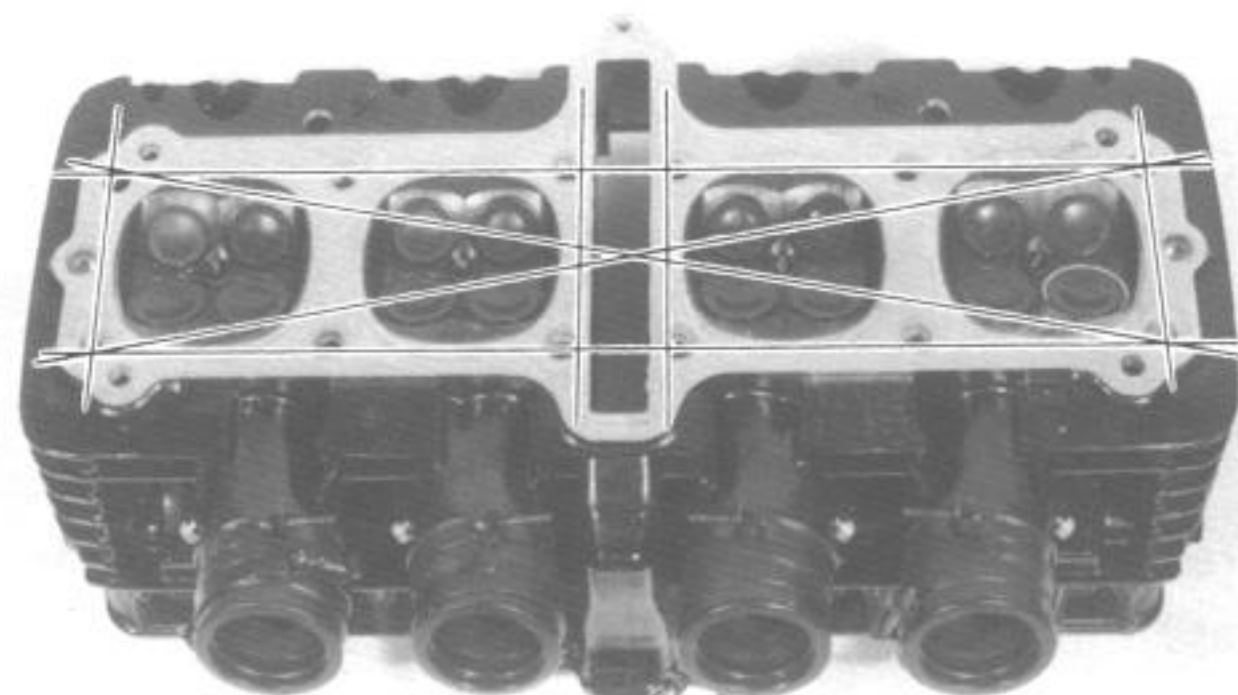

VALVE FACE WEAR

- Visually inspect each valve for wear of its seating face. Replace any valve with an abnormally worn face.
- The thickness T decreases as the wear of the face advances. Measure the thickness and, if the thickness is found to have been reduced to the limit, replace it.

Service Limit	0.5 mm
---------------	--------

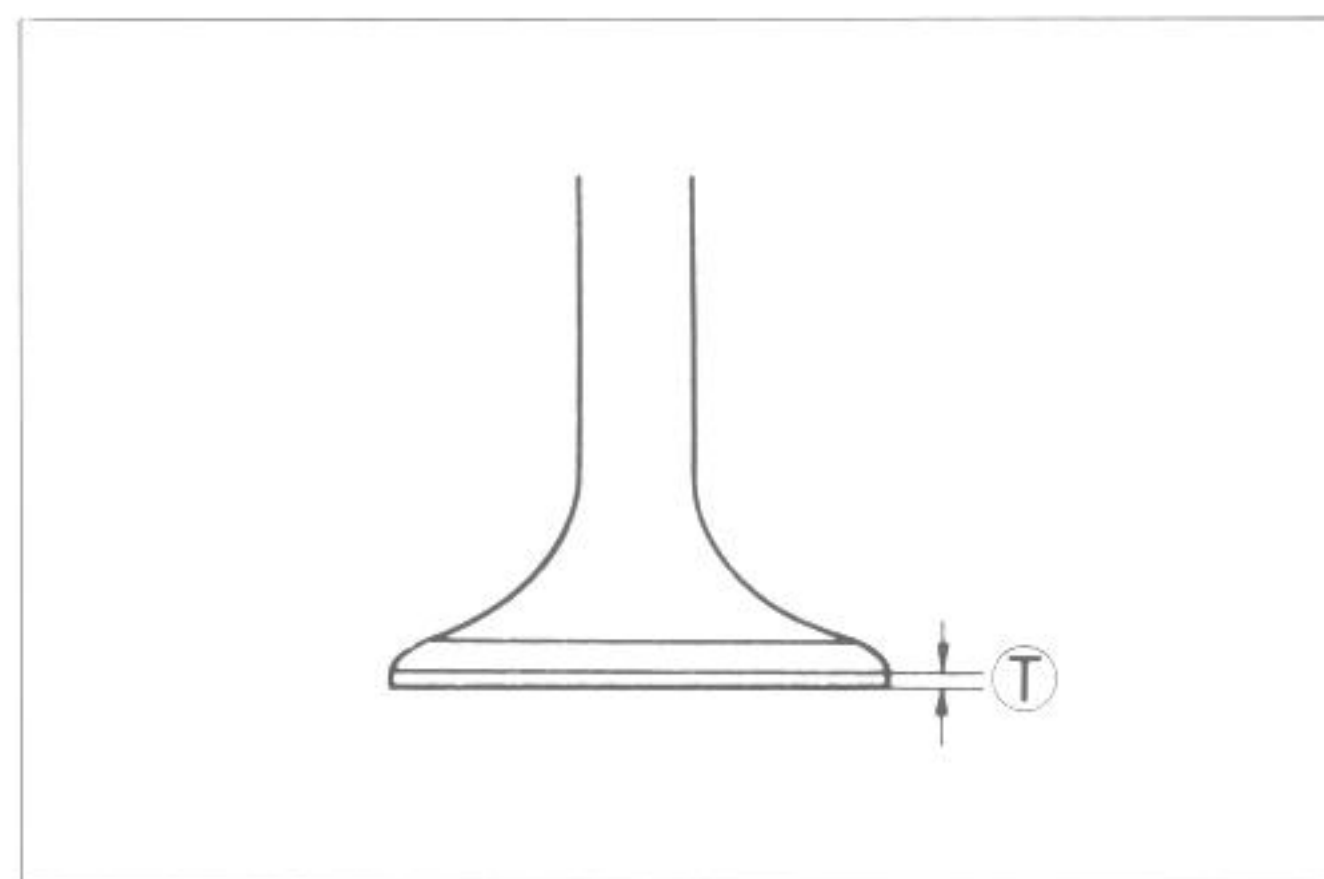

VALVE STEM RUNOUT

- Support the valve with "V" blocks, as shown, and check its runout with a dial gauge. The valve must be replaced if the runout exceeds the limit.

09900-21303	V-block set
09900-20606	Dial gauge (1/100 mm)
09900-20701	Magnetic stand

Service Limit	0.05 mm
---------------	---------

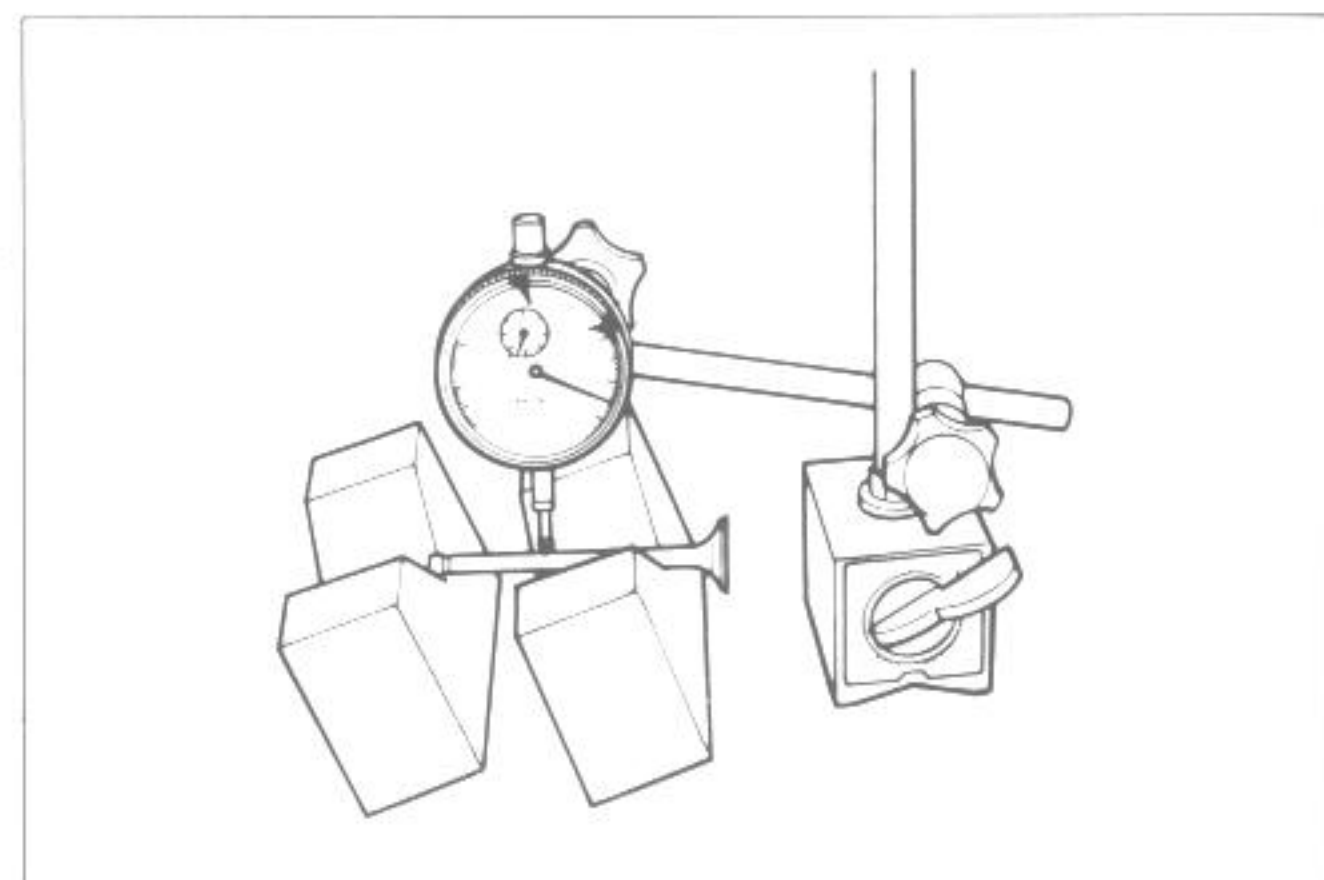

VALVE HEAD RADIAL RUNOUT

- Place the dial gauge at the position shown and measure the valve head radial runout. If it measures more than limit, replace the valve.

Service Limit	0.03 mm
---------------	---------

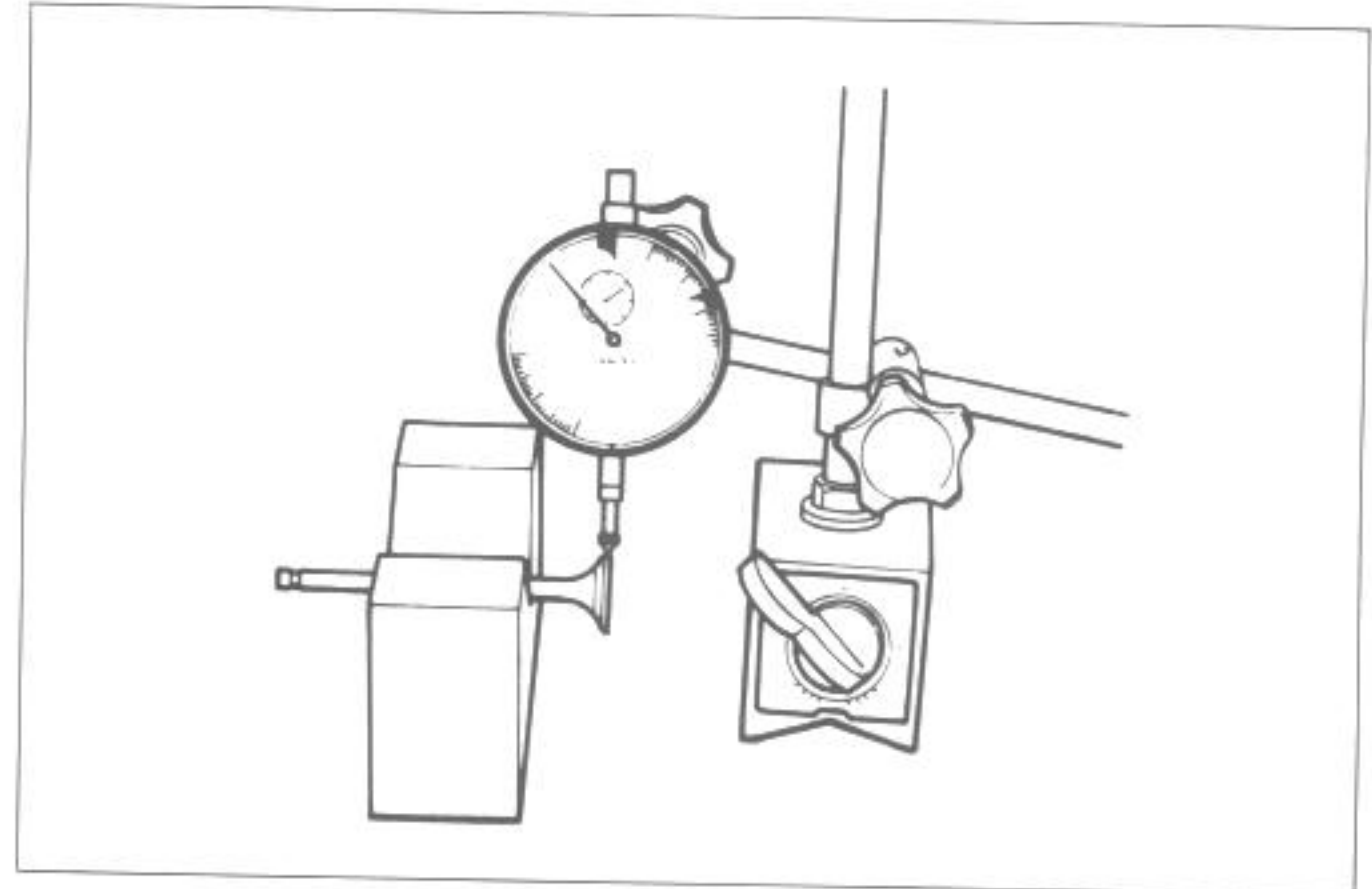

VALVE STEM DEFLECTION

Lift the valve about 10 mm (0.39 in) from the valve seat. Measure the valve stem deflection in two directions, "X" and "Y", perpendicular to each other, by positioning the dial gauge as shown. If the deflection measured exceeds the limit, (see below) then determine whether the valve or the guide should be replaced with a new one.

Valve	Service Limit
Intake valves	0.35 mm
Exhaust valves	0.35 mm

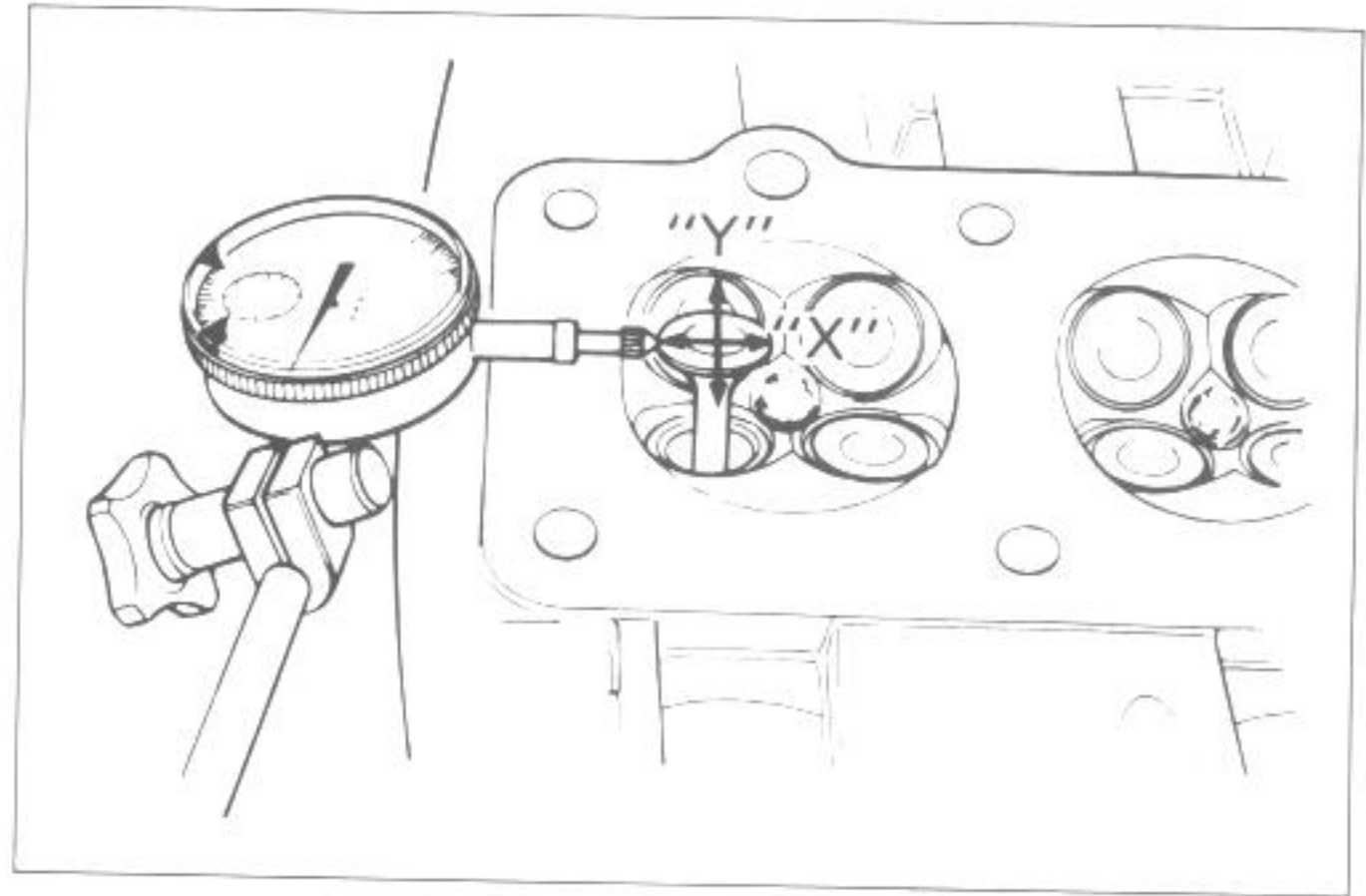

VALVE STEM WEAR

If the valve stem is worn down to the limit, as measured with a micrometer, where the clearance is found to be in excess of the limit indicated, replace the valve; if the stem is within the limit, then replace the guide. After replacing valve or guide, be sure to recheck the clearance.

09900-20205	Micrometer (0 – 25 mm)
-------------	---------------------------

Valve	Standard
Intake valves	5.470 – 5.487 mm
Exhaust valves	5.445 – 5.460 mm

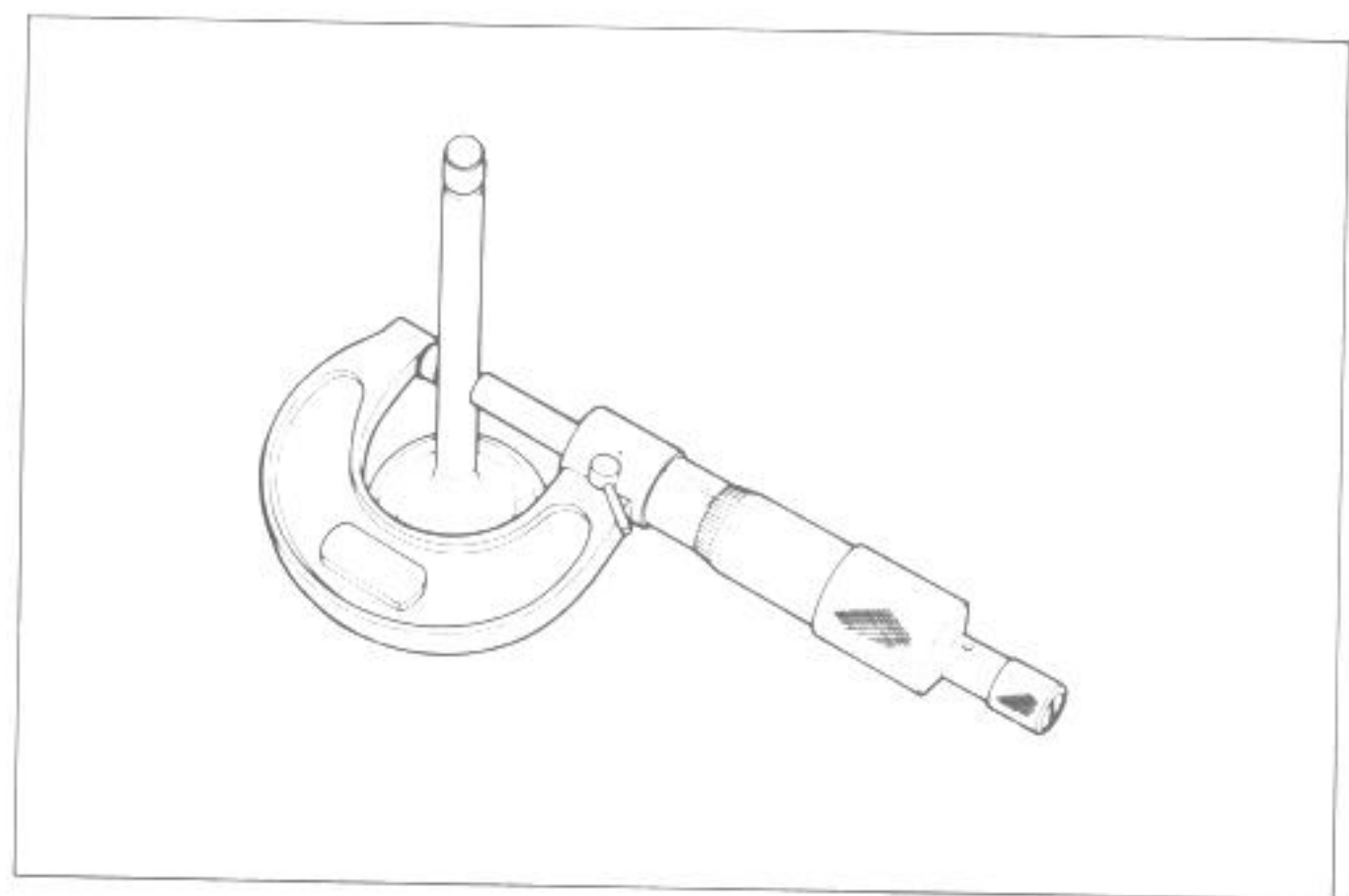

VALVE GUIDE SERVICING

- Using valve guide remover, drive the valve guide out toward camshaft side.

NOTE:

Discard the removed valve guide sub-assemblies.
Only oversized valve guides are available.

09916-44910	Valve guide remover
-------------	---------------------

- Re-finish the valve guide holes in cylinder head with a 11.3 mm reamer.

09916-34561	Valve guide hole reamer
09916-34541	Reamer handle

- Fit a ring to each valve guide. Be sure to use new rings and valve guides. Reuse of rings and valve guides removed during disassembly is prohibited. Remember that both valve guides for intake and exhaust and both oil seals are identical in shape.

11115-49200	Valve guide
09289-05003	Valve guide oil seal

- Oil the stem hole, too, of each valve guide and drive the guide into the guide hole with the valve guide installer and attachment.

09916-44910	Valve guide installer
09916-44920	Valve guide installer attachment

CAUTION:

Failure to oil the valve guide hole before driving the new guide into place may result in a damaged guide or head.

- Re-finish the valve guide inner surface with a 5.5 mm reamer.

09916-34550	Valve guide reamer
09916-34541	Reamer handle

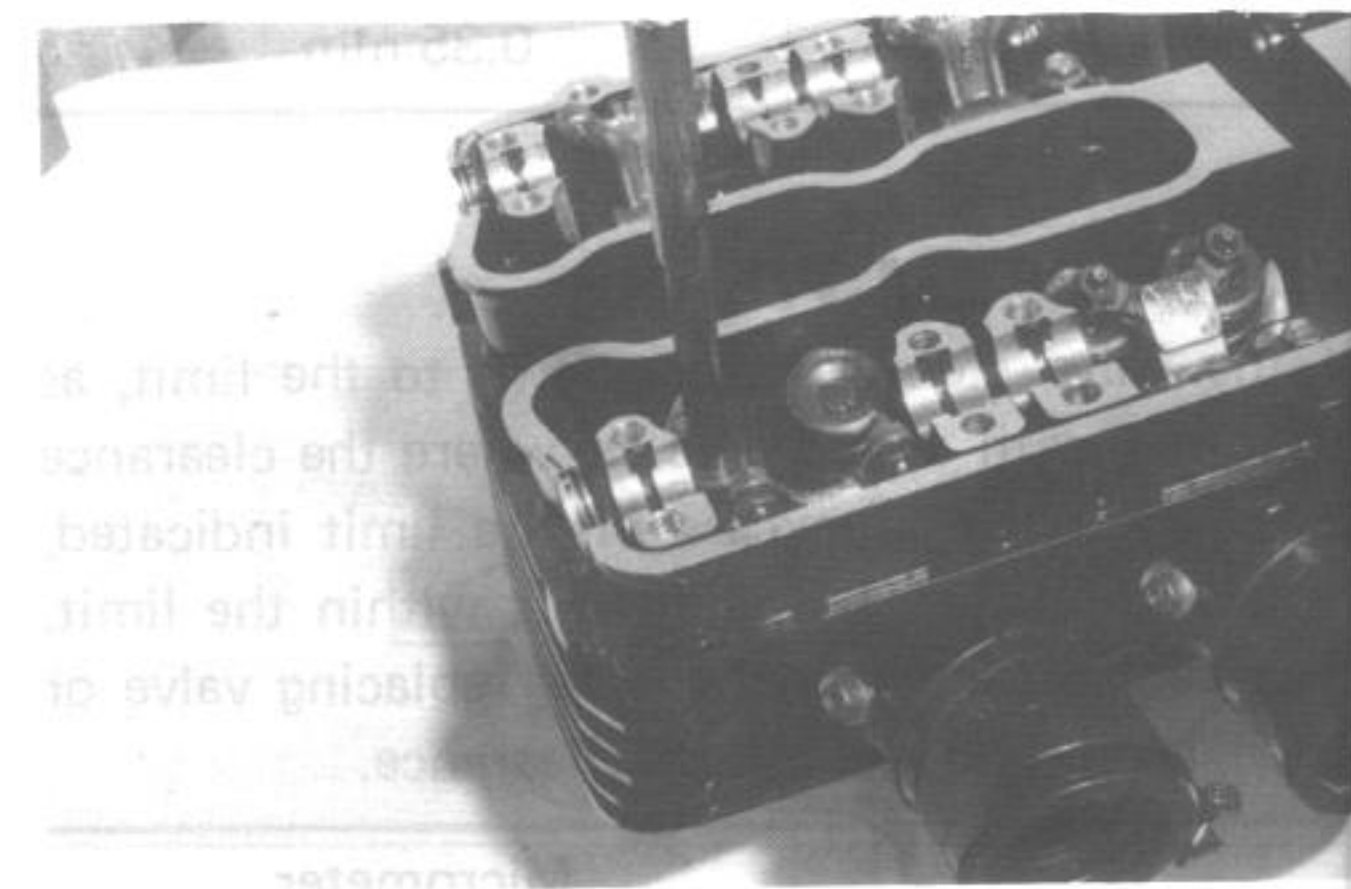
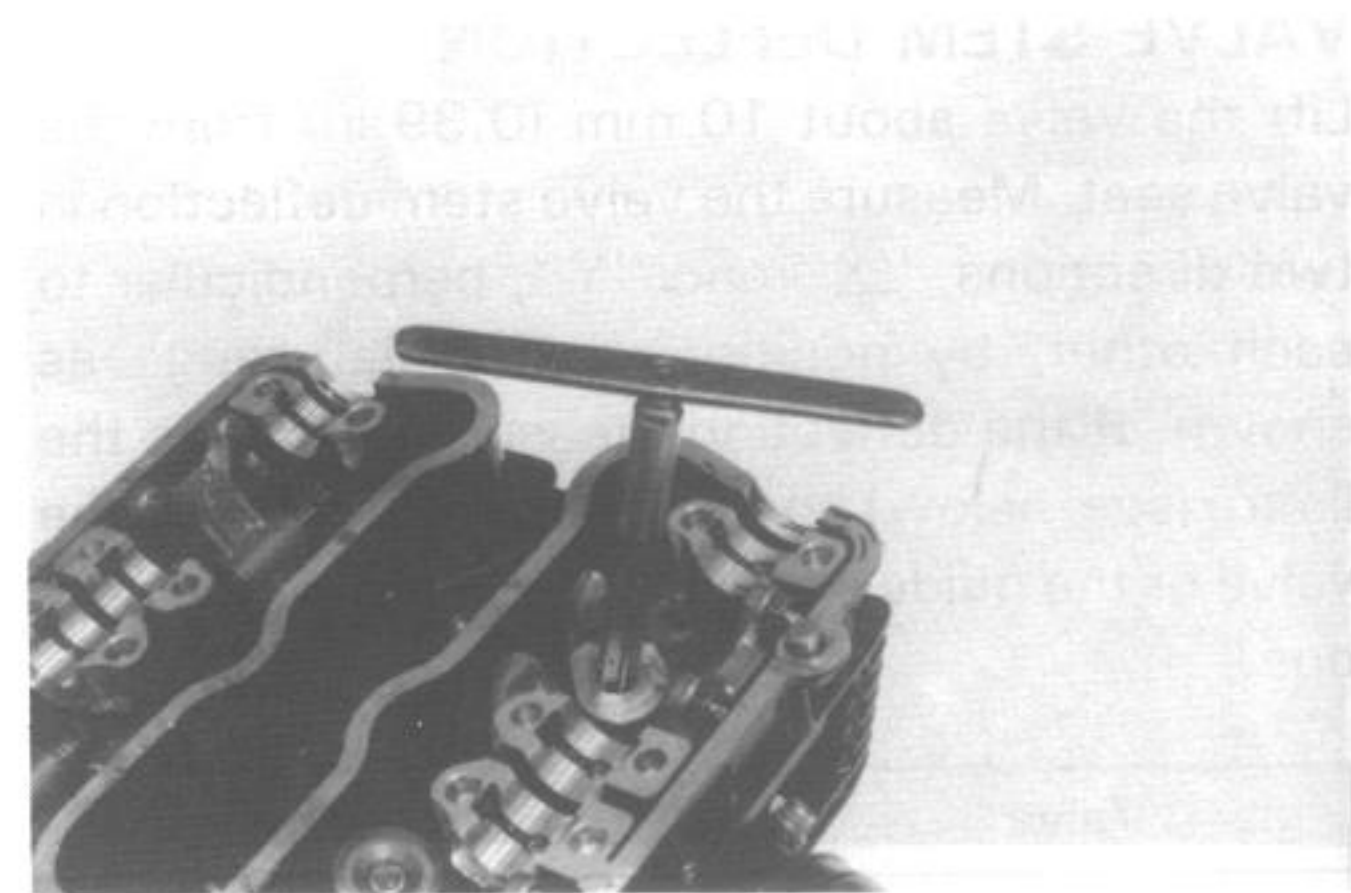
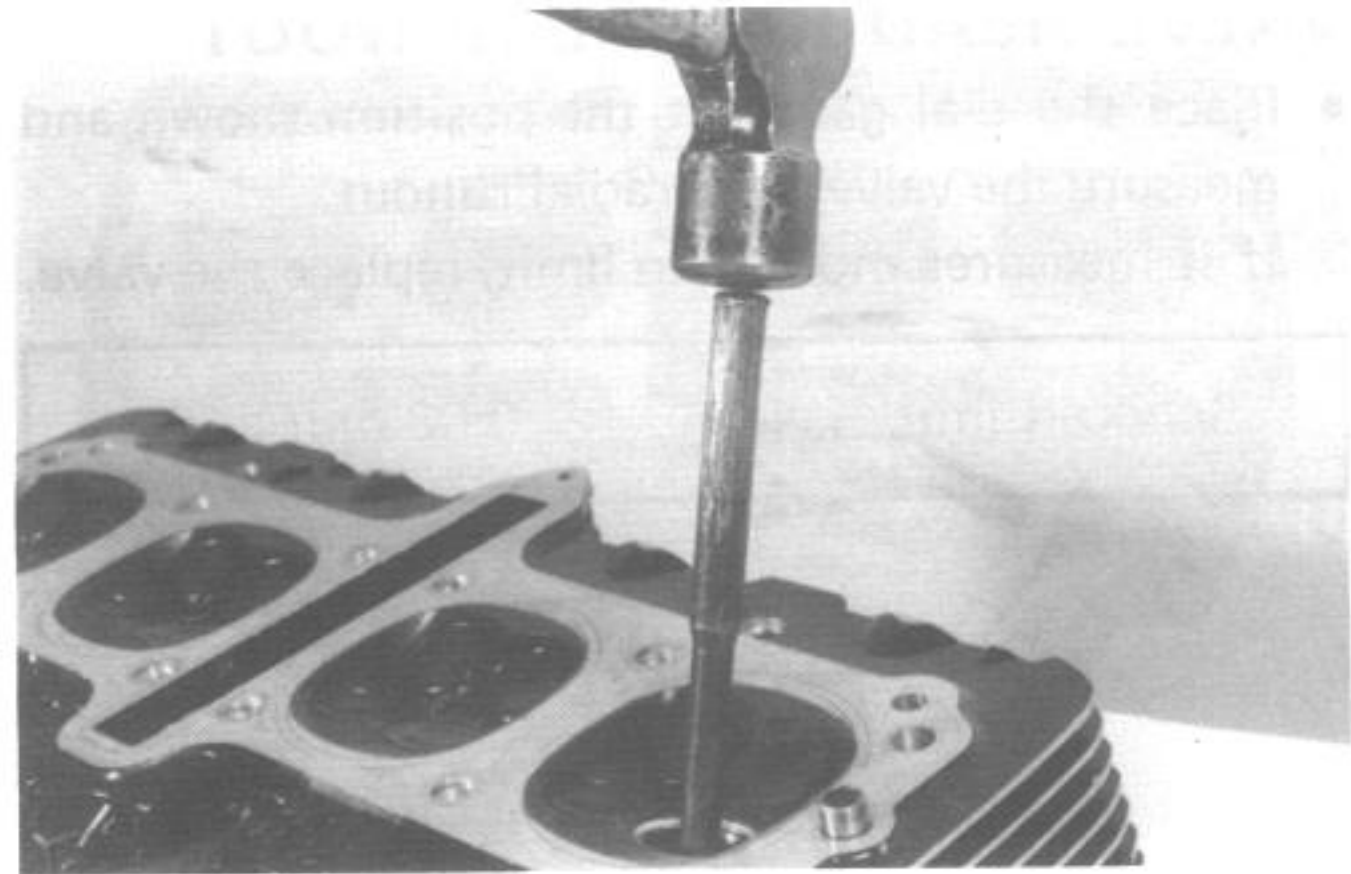

VALV

- Coa
Fit
valv
obt
In
the
- The
face
and
of
"wi
catic

Valve s

S

If eithe
by serv

VALV

The va
valves a
seat cor
the cor
chambe

099
099
099

45
15

NOTE
The va
after e

- Insert
Install
- Using
seat w

VALVE SEAT WIDTH

- Coat the valve seat with Prussian blue uniformly. Fit the valve and tap the coated seat with the valve face in a rotating manner, in order to obtain a clear impression of the seating contact. In this operation, use the valve lapper to hold the valve head.
- The ring-like dye impression left on the valve face must be continuous — without any break — and, in addition to this requirement, the width of the dye ring, which is the visualized seat "width", must be within the following specification:

Valve seat width

Seat width	Standard
Ⓜ	0.9 – 1.1 mm

If either requirement is not met, correct the seat by servicing it as follows:

VALVE SEAT SERVICING

The valve seats for both the intake and exhaust valves are machined to two different angles. The seat contact surface is cut 45° and the area above the contact surface (closest to the combustion chamber) is cut to 15°.

09916-24420	Valve seat cutter (N-116)
09916-29010	Valve seat cutter (N-120)
09916-24310	Solid pilot (N-100-5.0)

	Intake	Exhaust
45°	N-116	N-116
15°	N-116	N-120

NOTE:

The valve seat contact area must be inspected after each cut.

- Insert the pilot ① with a slight rotation. Install the 45° cutter, attachment and T handle.
- Using the 45° cutter, descale and cleanup the seat with one or two turns.

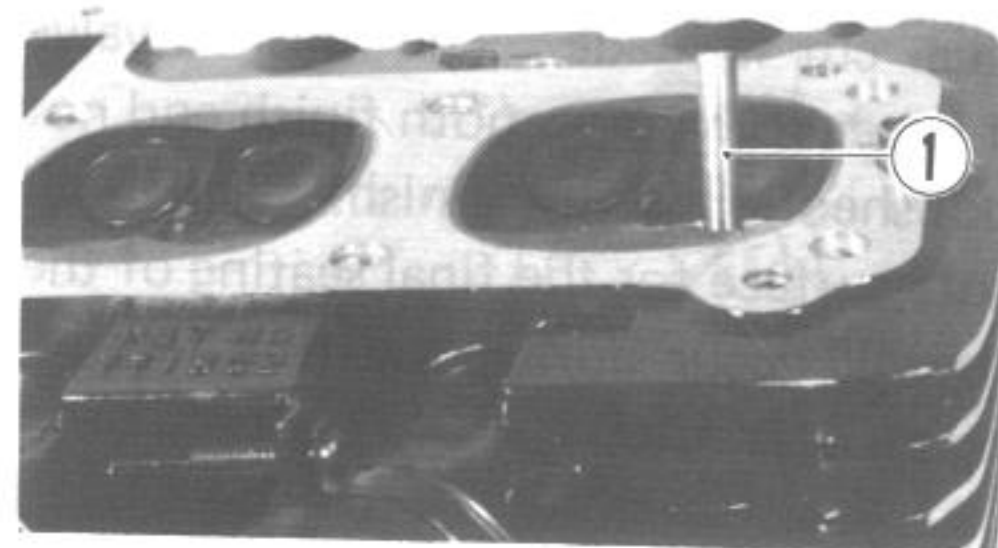
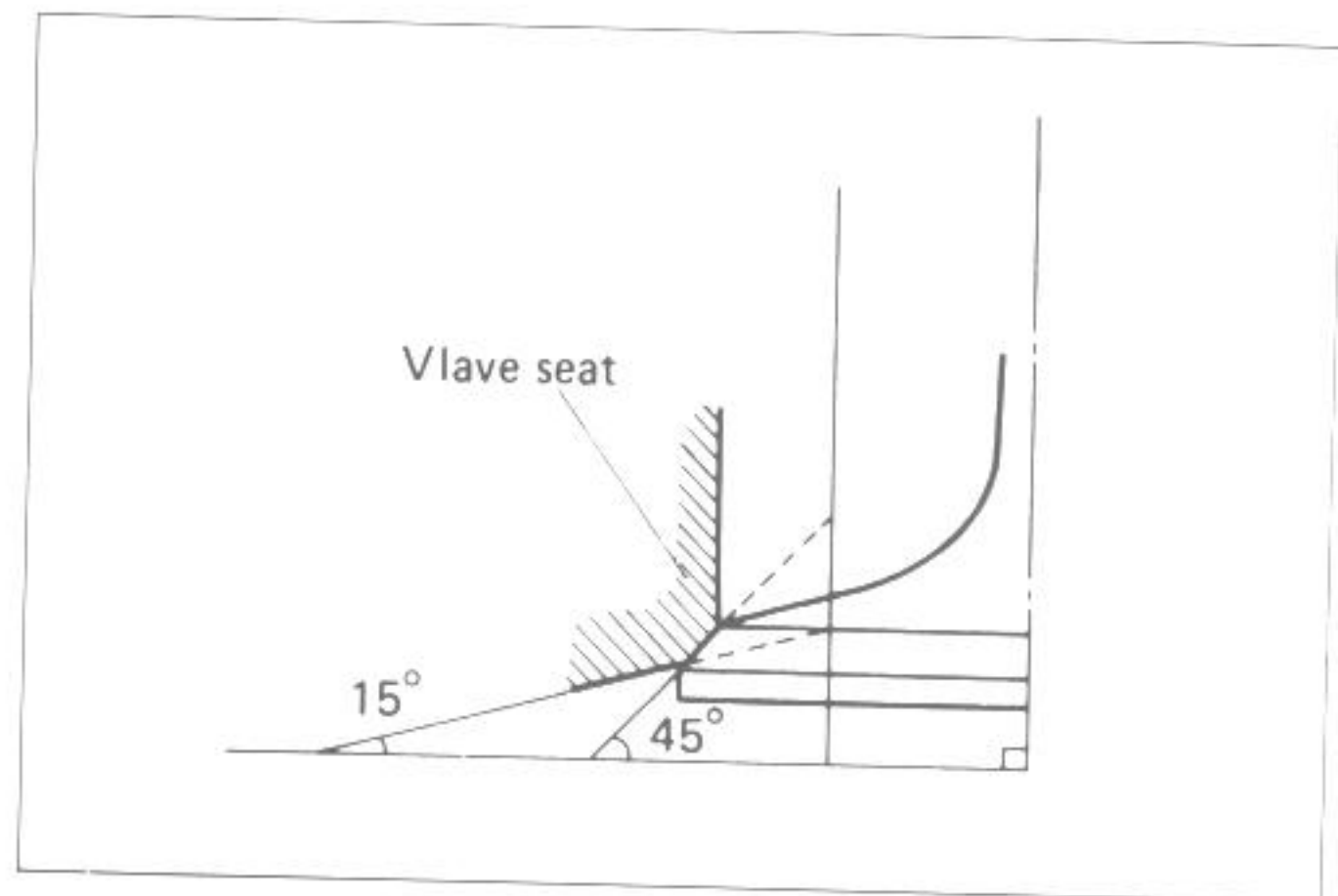
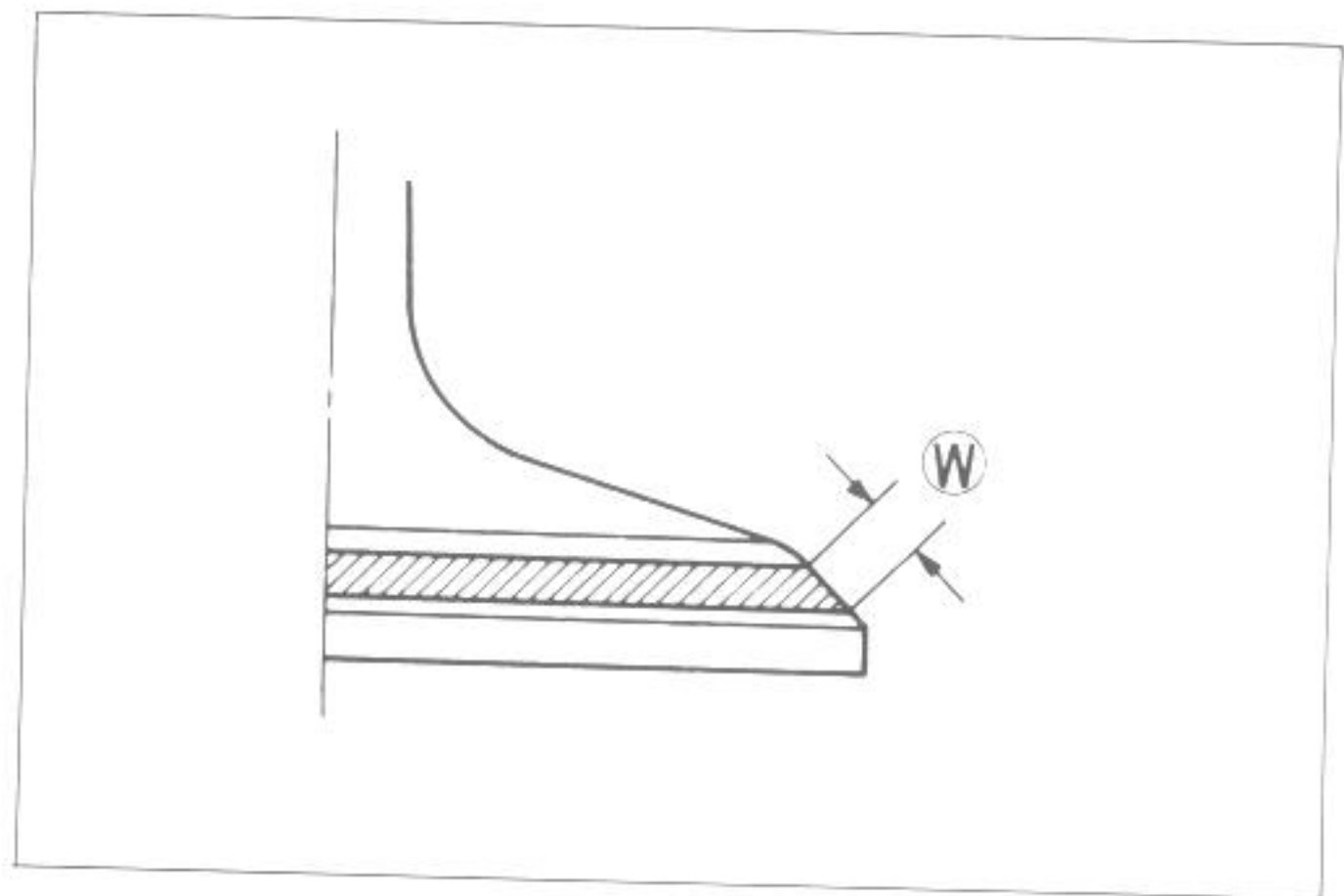
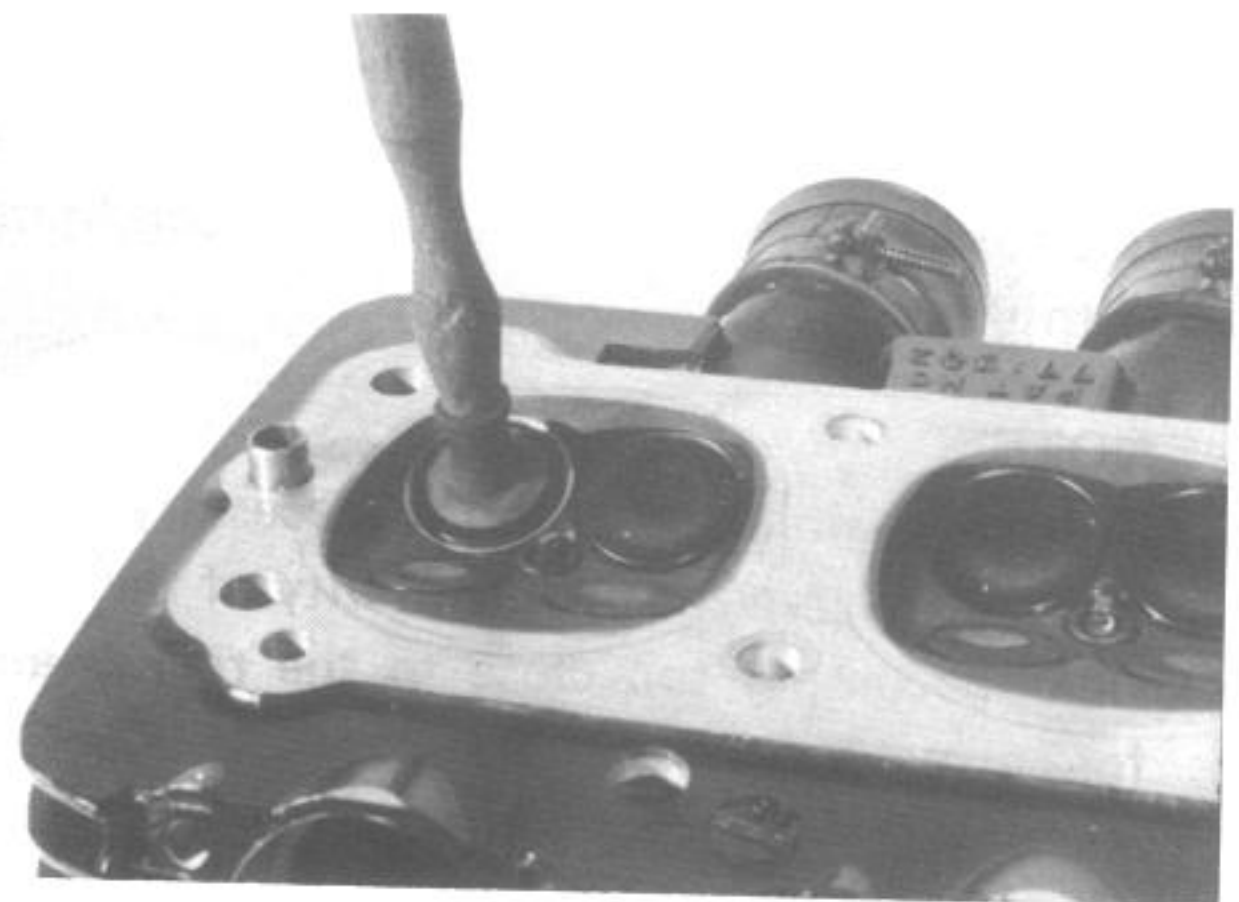

- Inspect the seat by the previously described seat width measurement procedure. If the seat is pitted or burned, additional seat conditioning with the 45° cutter is required.

NOTE:

Cut the minimum amount necessary from the seat to prevent the possibility of the valve stem becoming too close to the rocker arm for correct valve contact angle.

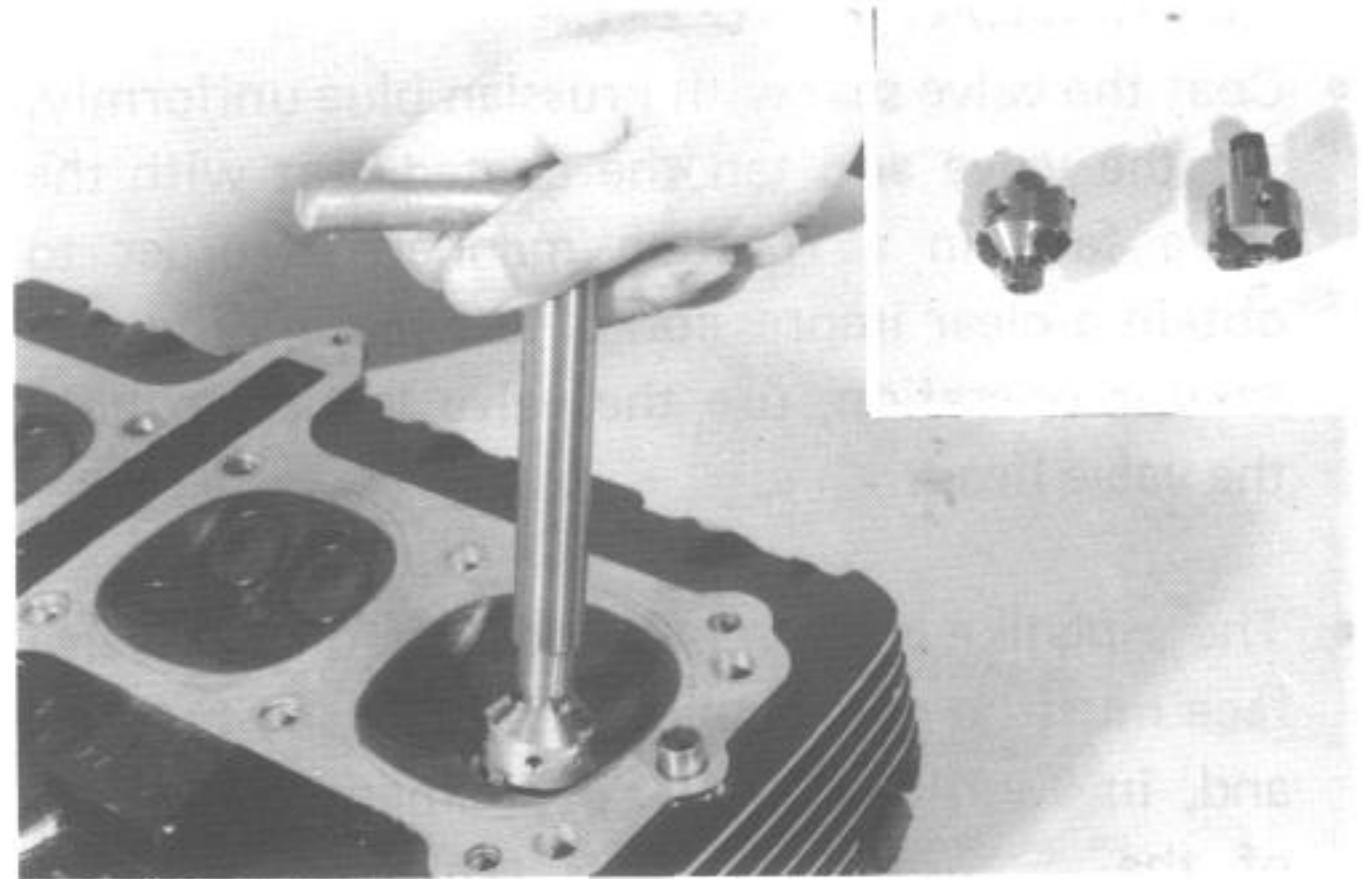

If the contact area is too high and too wide on the face of valve, use a 15° cutter to lower and narrow the contact area.

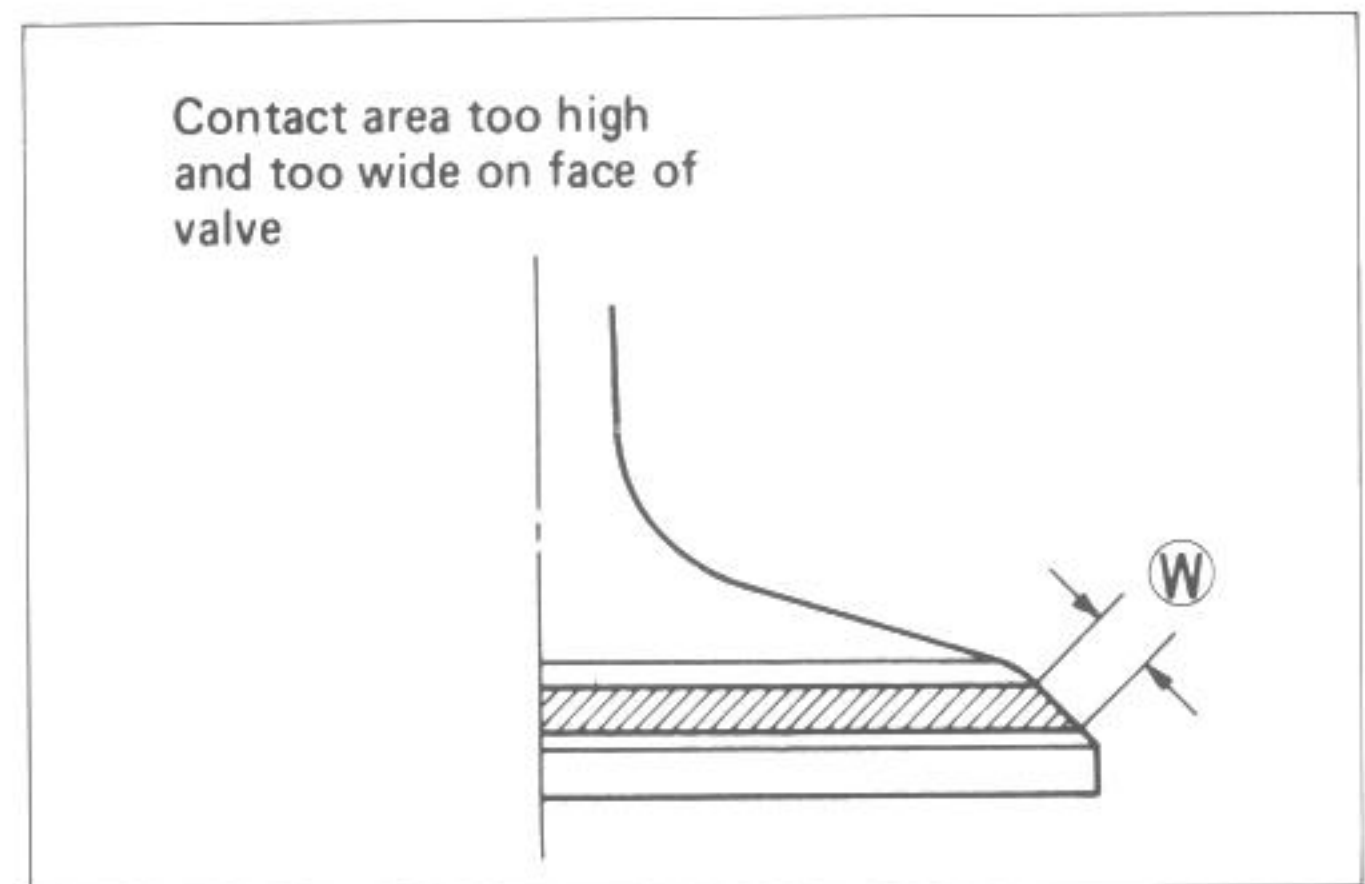

If the contact area is too low and too narrow, use the 45° cutter to raise and widen the contact area.

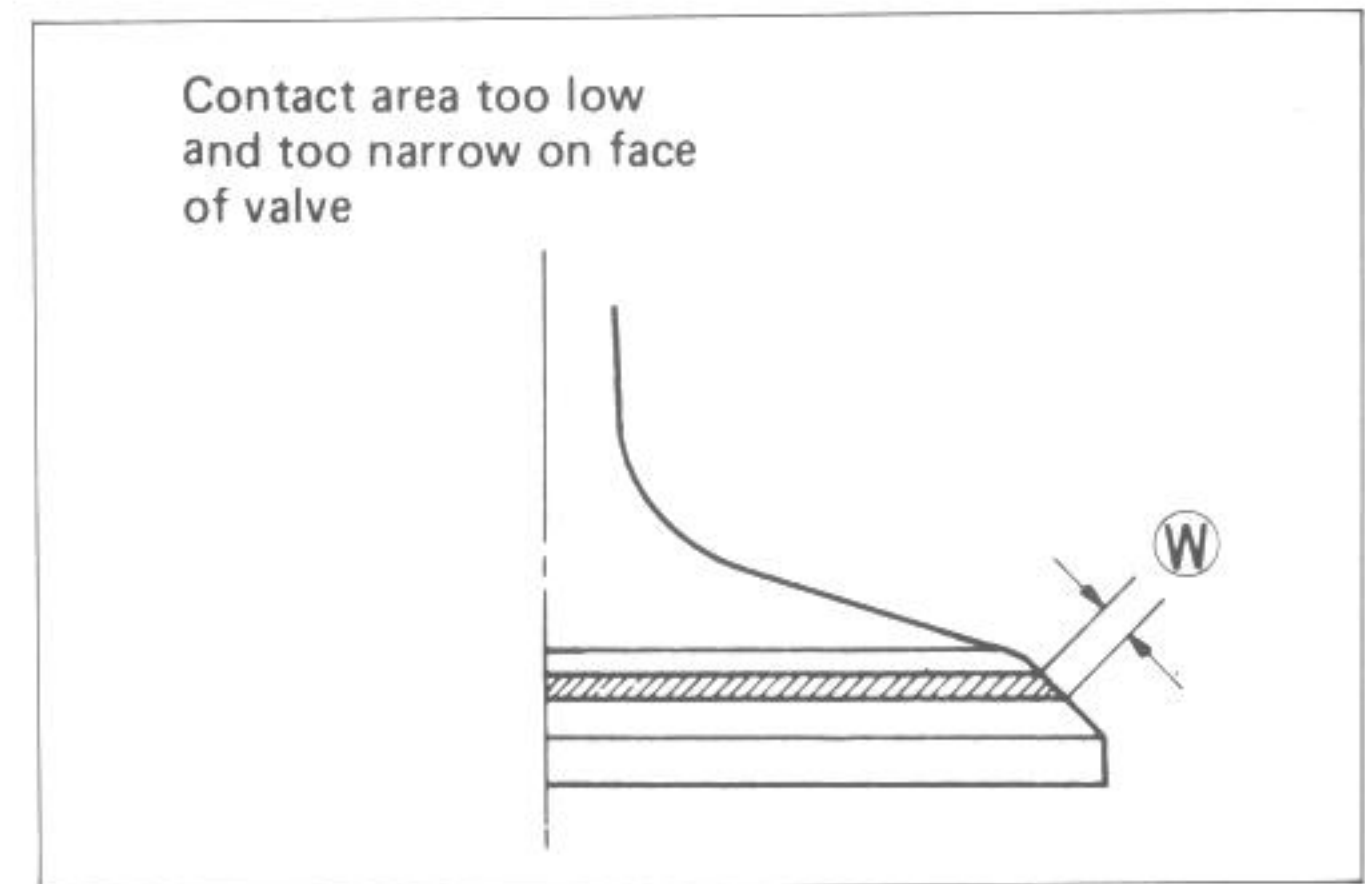

- After the desired seat position and width is achieved, use the 45° cutter very lightly to clean up any burrs caused by the previous cutting operations. DO NOT use lapping compound after the final cut is made. The finished valve seat should have a velvety smooth finish and not a highly polished or shiny finish. This will provide a soft surface for the final seating of the valve which will occur during the first few seconds of engine operation.

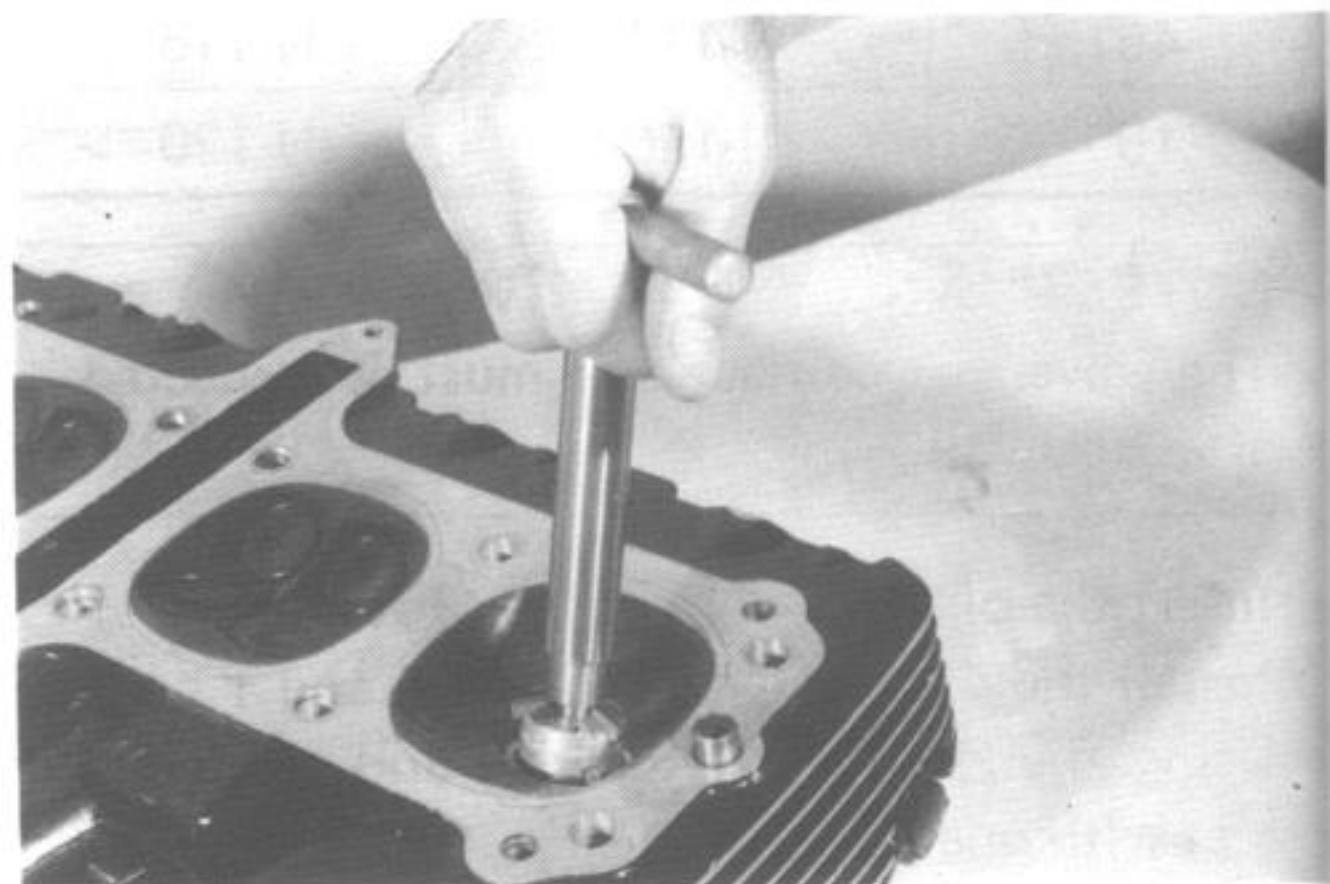

- C
p
g
in
th

W
A
g

N
A
ad
he

CA

*

*

A

H

V

VALVE

- The seat
eng
cha
cha
- Che
thei
com
ed b
forc
repla
a set

CAUTION

Repl
out
to be

- Clean and assemble the head and valve components. Fill the intake and exhaust ports with gasoline to check for leaks. If any leaks occur, inspect the valve seat and face for burrs or other things that could prevent the valve from sealing.

WARNING:

Always use extreme caution when handling gasoline.

NOTE:

After servicing the valve seats, be sure to adjust the valve clearance after the cylinder head has been reinstalled. (see page 2-6)

CAUTION:

- * Refacing valve stem end face is permissible where the length ① will not be reduced to less than 3.8 mm. If this length becomes shorter than 3.8 mm, then the valve must be replaced.
- * After installing the valve whose stem end has been ground off as above, check that the face ② of valve stem end is above the valve cotter ③.

VALVE SPRINGS

- The force of the two coil springs keeps the valve seats tight. Weakened springs result in reduced engine power output, and often account for the chattering noise coming from the valve mechanism.
- Check the springs for strength by measuring their free lengths and also the force required to compress them. If the limit indicated is exceeded by the free length reading or if the measured force does not fall within the range specified, replace both the inner and outer springs as a set.

CAUTION:

Replace both the valve springs, at a time, outer and inner, if any one of these is found to be beyond the limit.

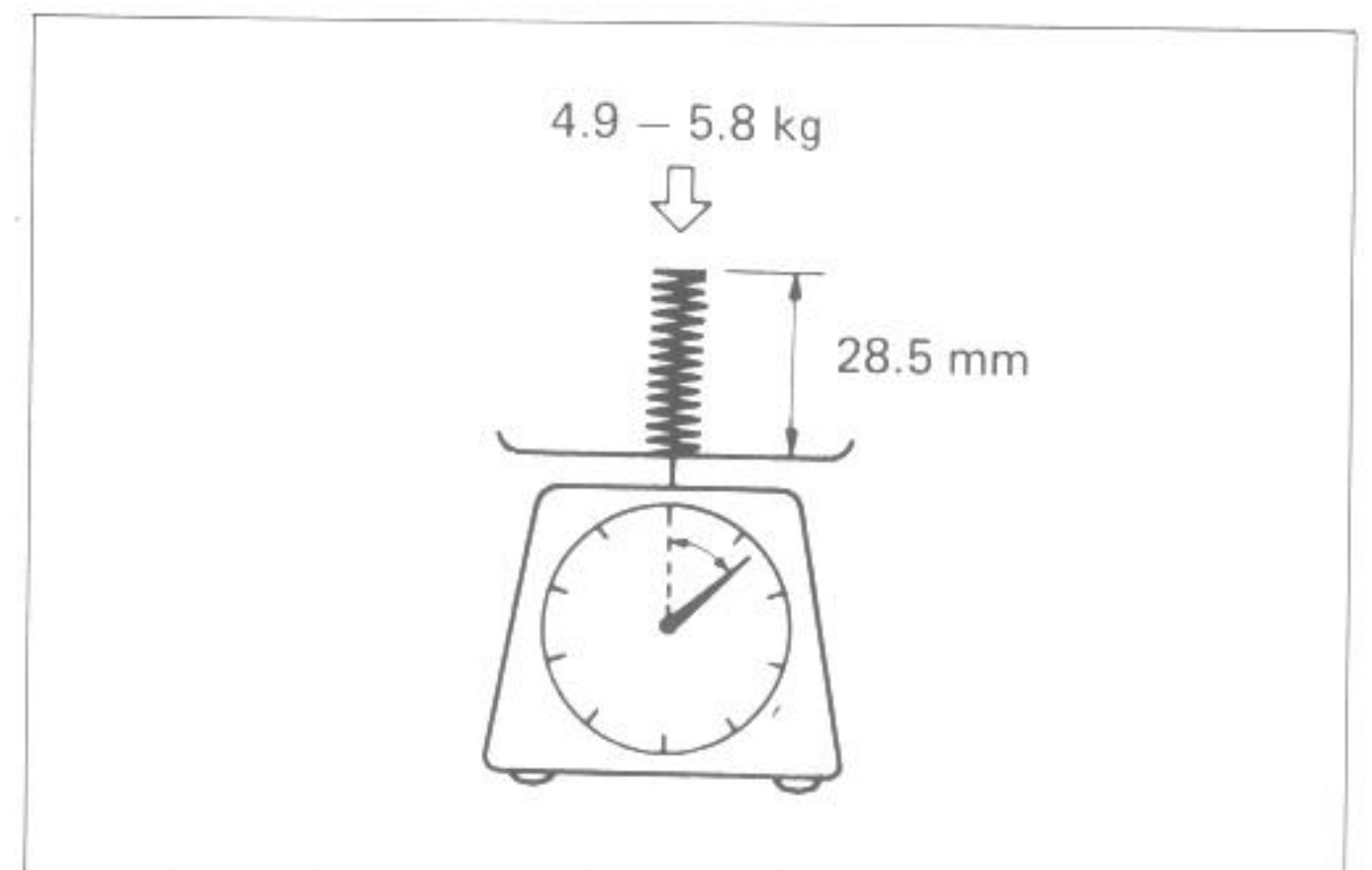
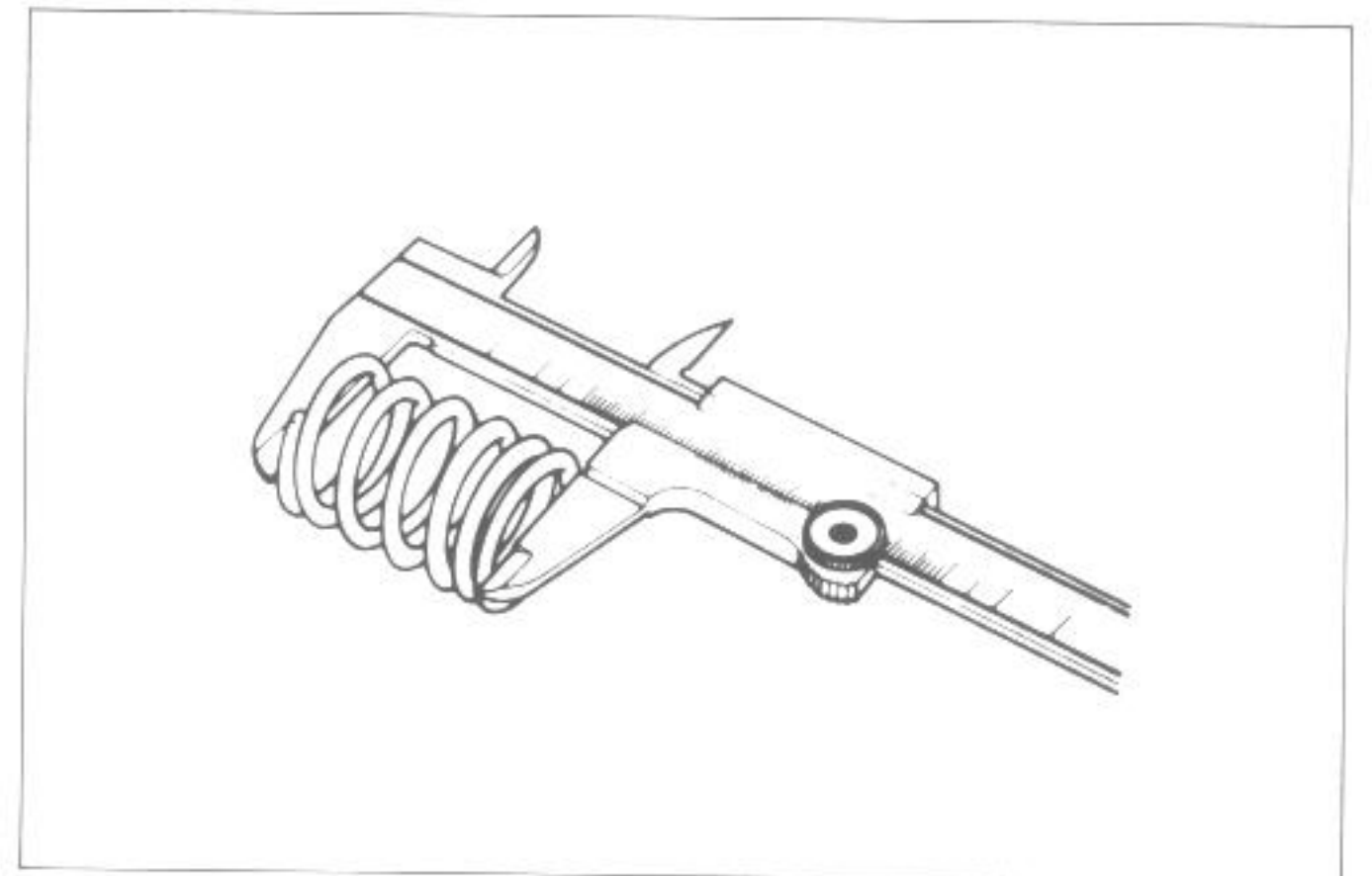
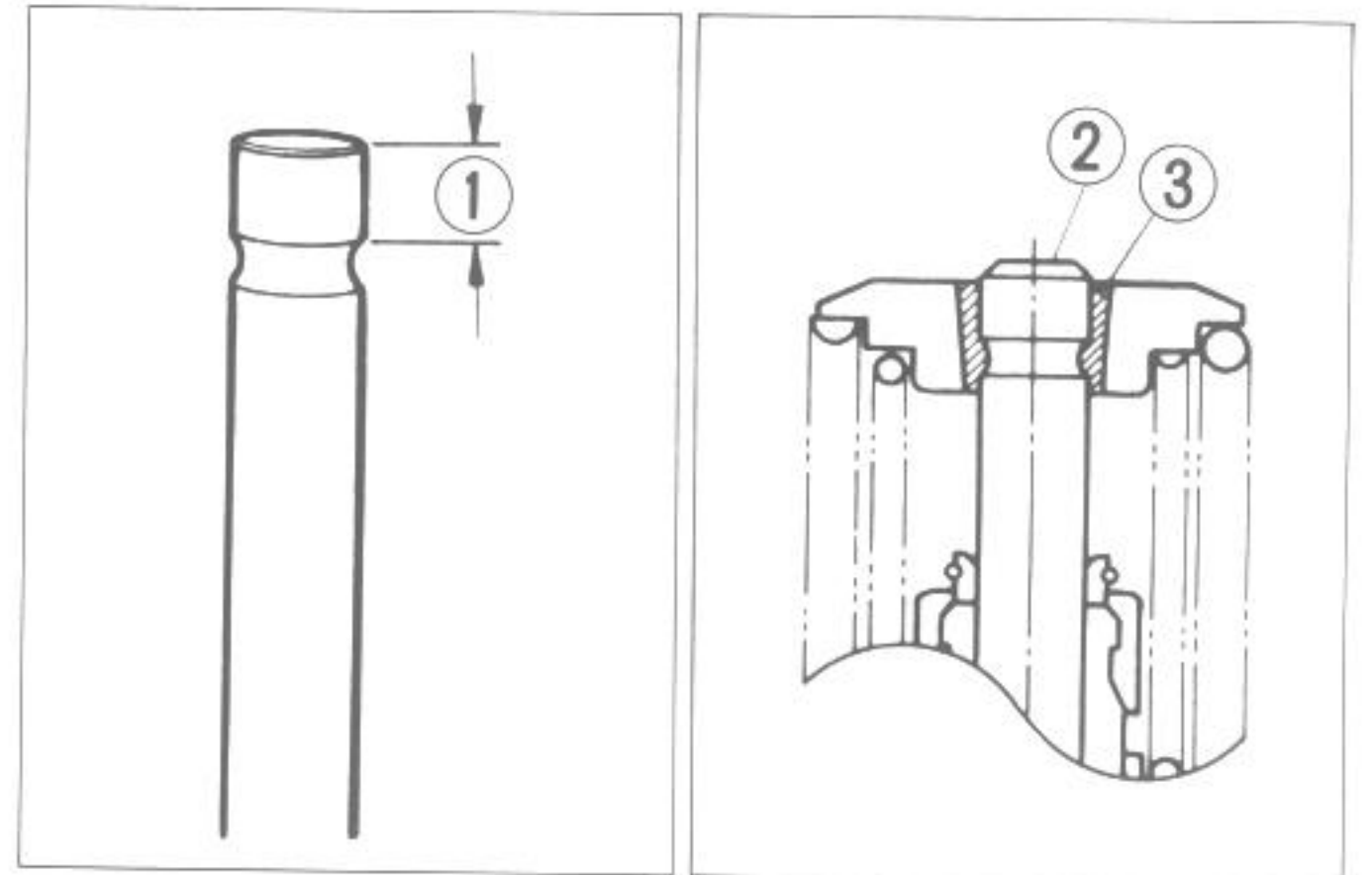
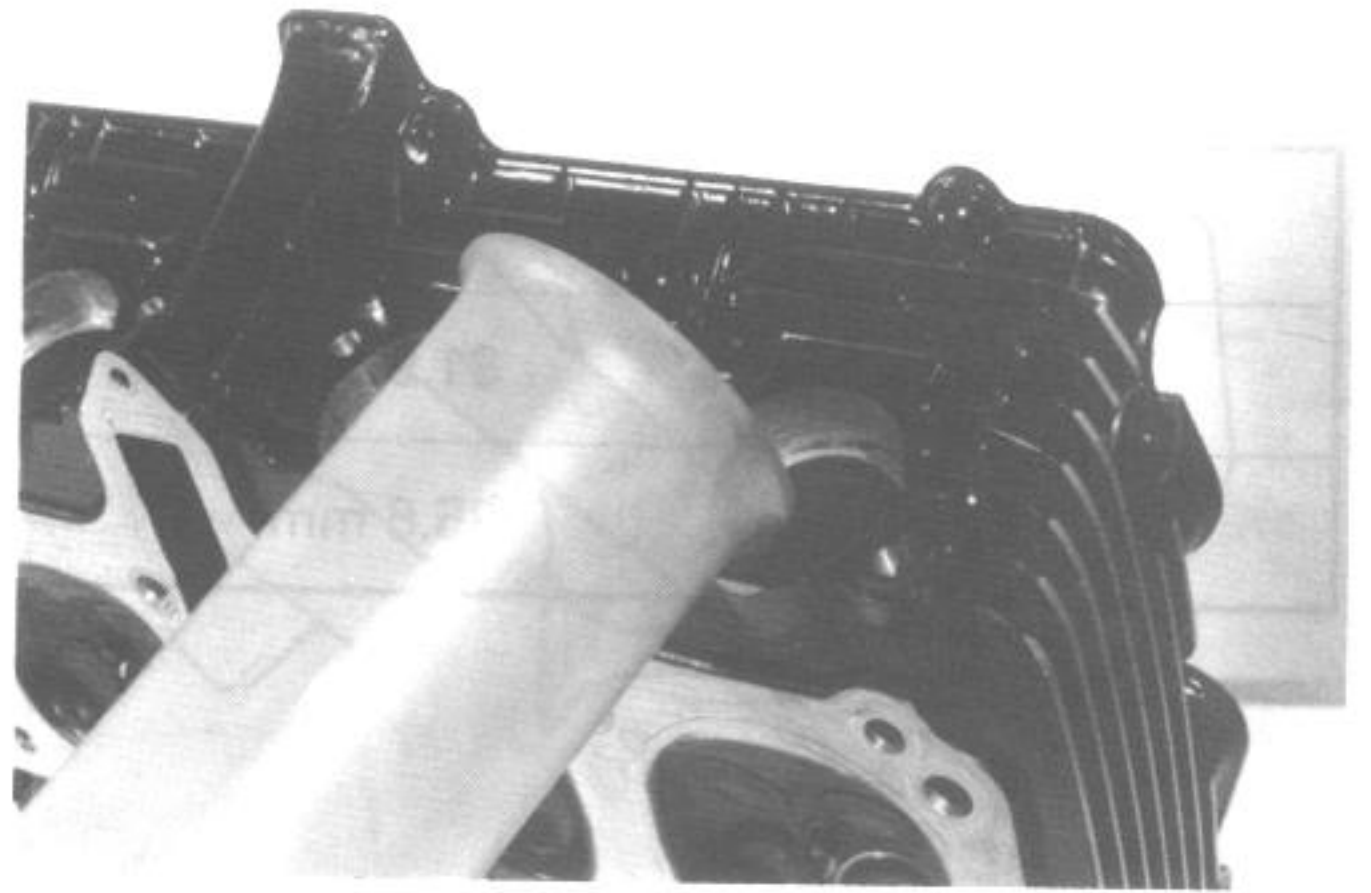

Valve spring free length

Spring	Service Limit
INNER	31.9 mm
OUTER	35.6 mm

Valve spring tension

Spring	Standard
INNER	4.9 – 5.8 kg/28.5 mm
OUTER	7.2 – 8.1 kg/32.0 mm

- Install the valve spring guide.

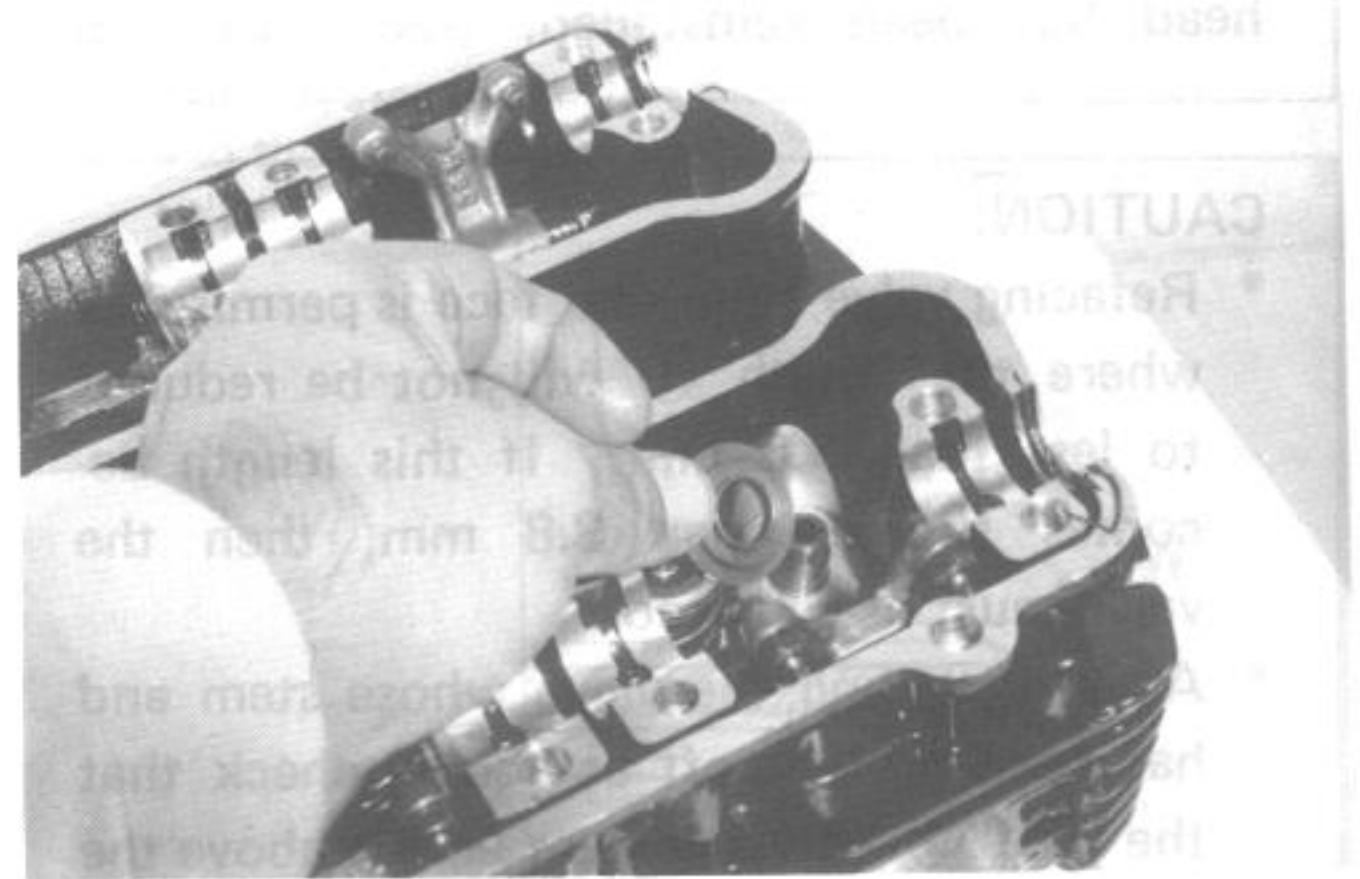

- Install the valve spring lower seats ①. Be careful not to confuse the lower seats with the spring retainer ②.

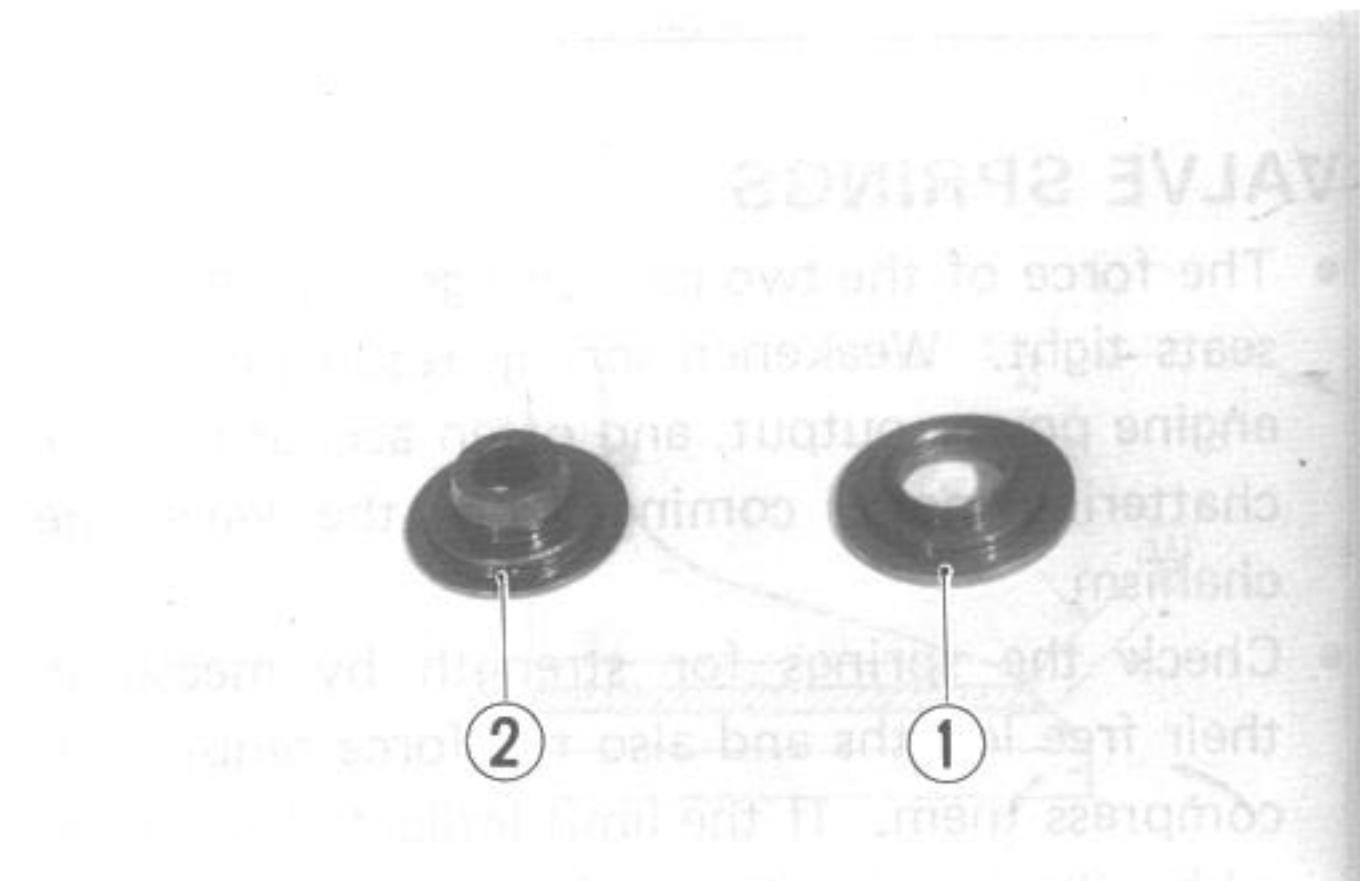

- Oil each oil seal, and drive them into position.

NOTE:

Do not use the oil seals removed in disassembly: use new seals.

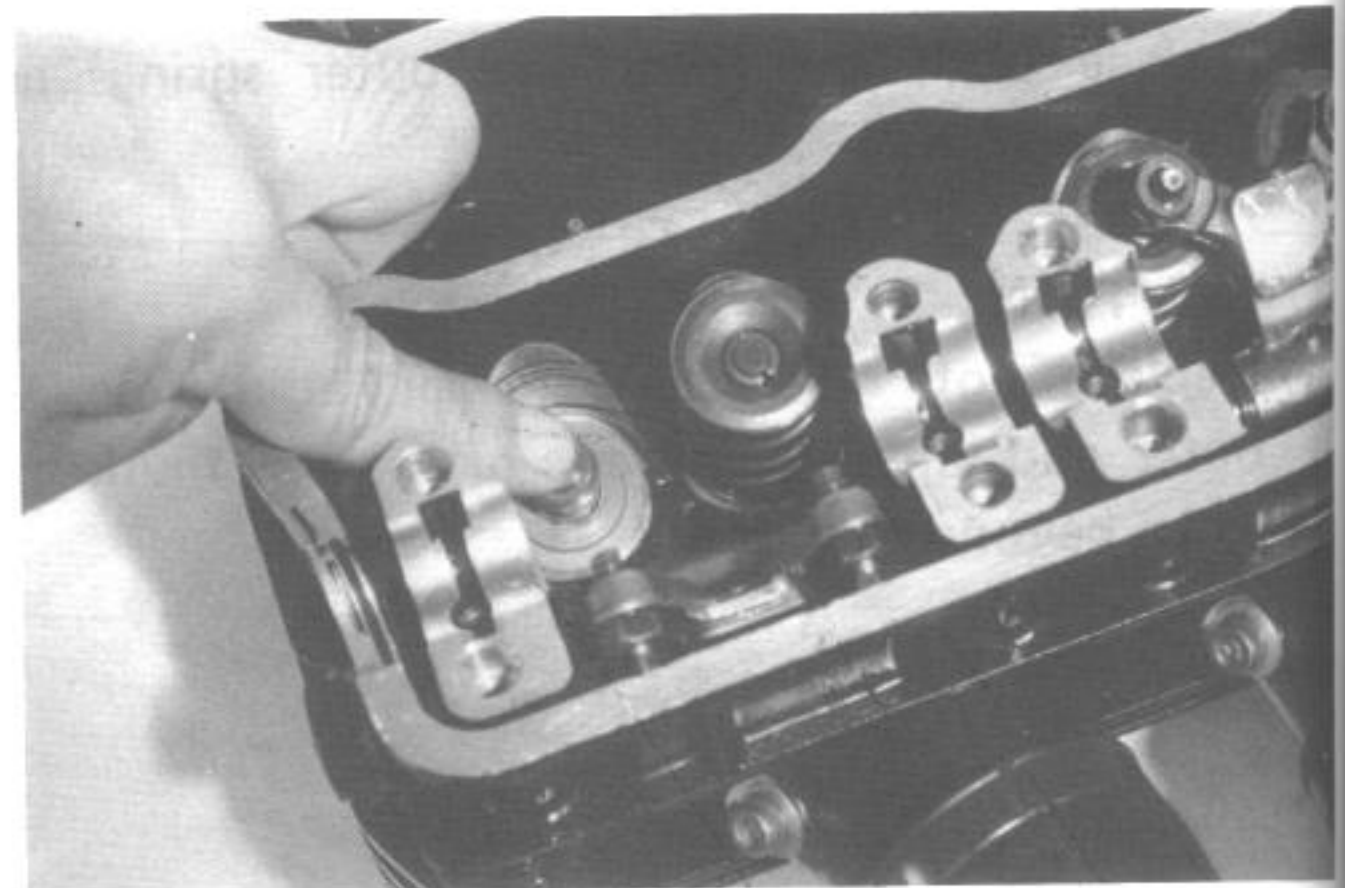

REASSEMBLY

- Insert the valves, with their stems coated with high quality molybdenum disulfide lubricant (SUZUKI MOLY PASTE) all around and along the full stem length without any break.

CAUTION:

When inserting each valve, take care not to damage the lip of the stem seal.

99000-25140

SUZUKI Moly Paste

- Install the valve spring and with the closed-pitch portion (A) facing cylinder head.
- (B) : Large-pitch portion.
- Put on the valve retainer and, using the valve lifter, press down the springs, fit the cotter halves to the stem end, and release the lifter to allow the cotter (1) to wedge in between seat and stem. Be sure that the rounded lip (2) of the cotter fits snugly into the groove (3) in the stem end.

09916-14510

Valve lifter

09916-14910

Valve lifter attachment

09916-84510

Tweezers

CAUTION:

Be sure to restore each spring and valve to their original positions.

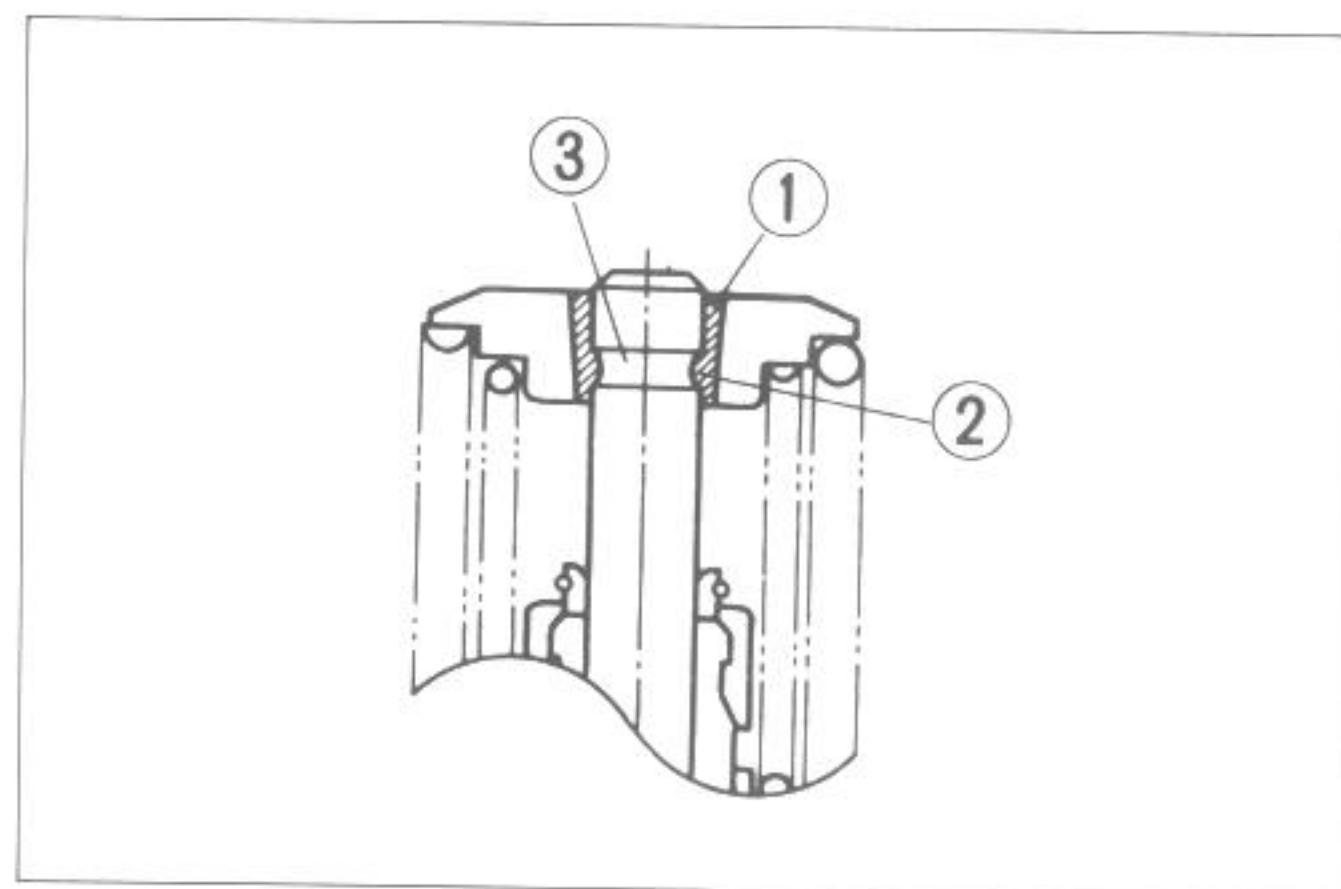
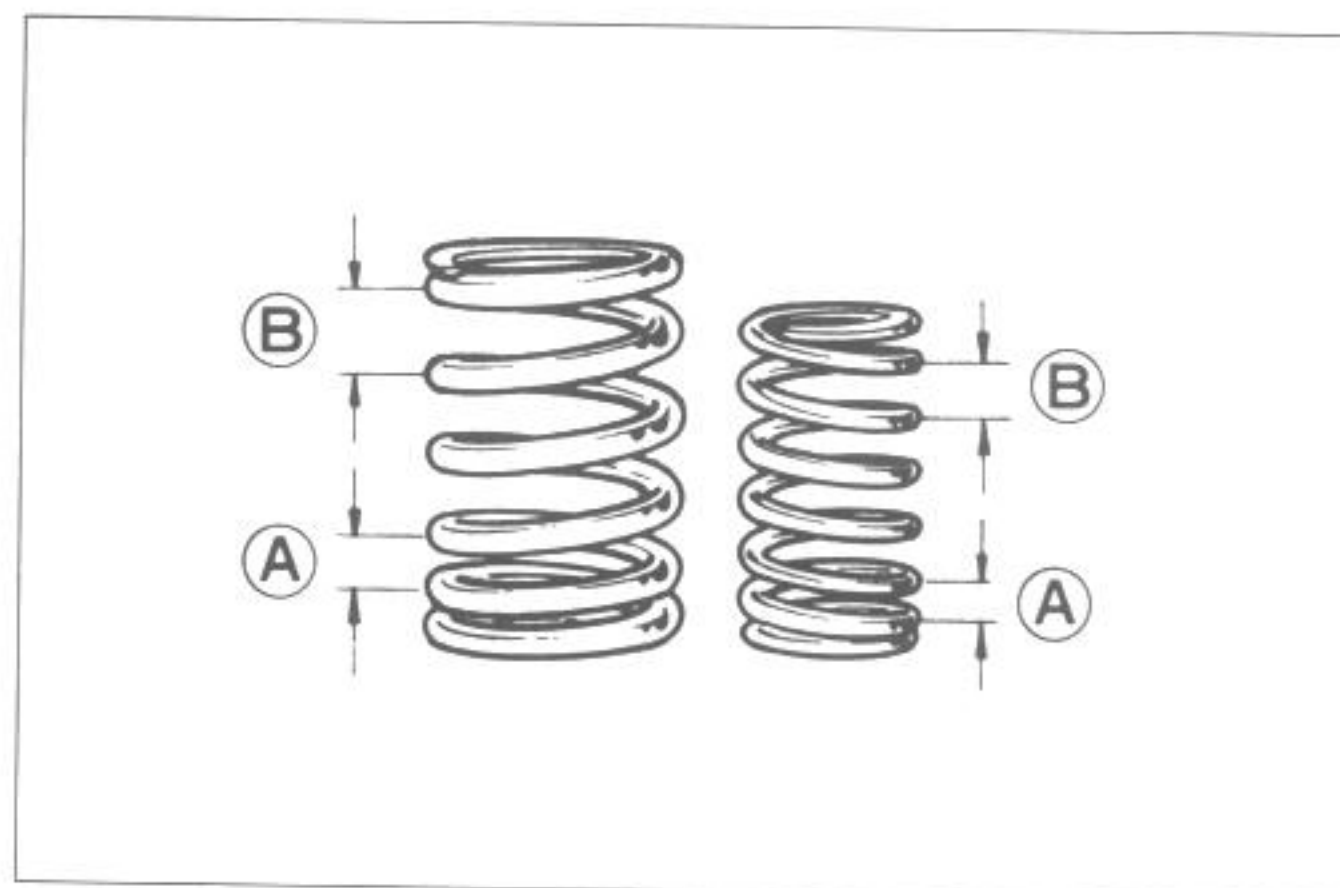
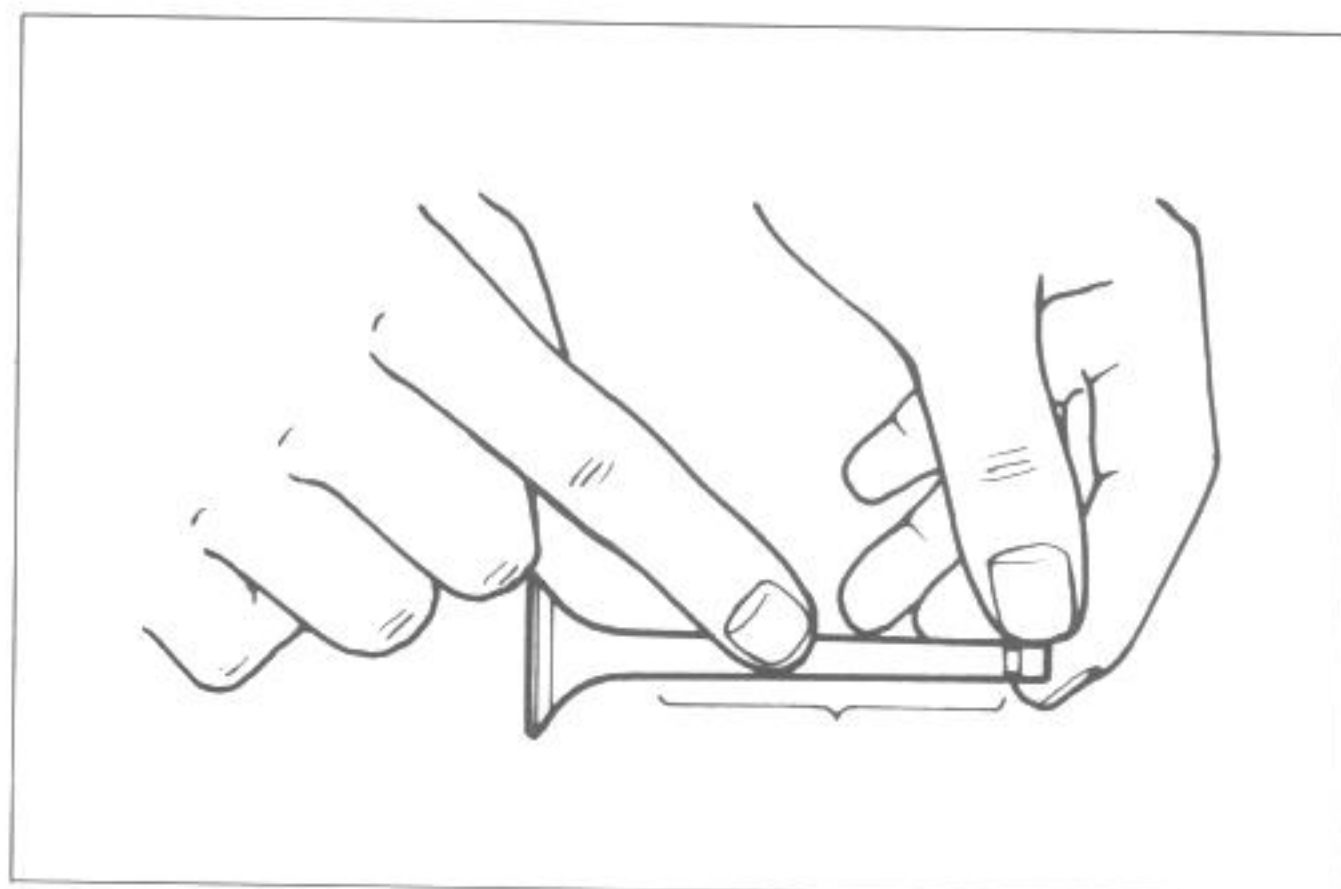

CAMSHAFT

- Both camshafts should be checked for runout and also for wear of cams and journals if the engine has been noted as giving abnormal noise or vibration or lack power output. Any of these conditions may be caused by camshafts worn down or distorted to the service limit.

- (A) : General markets
- (B) : For Austria, Sweden, Switzerland and W. Germany.

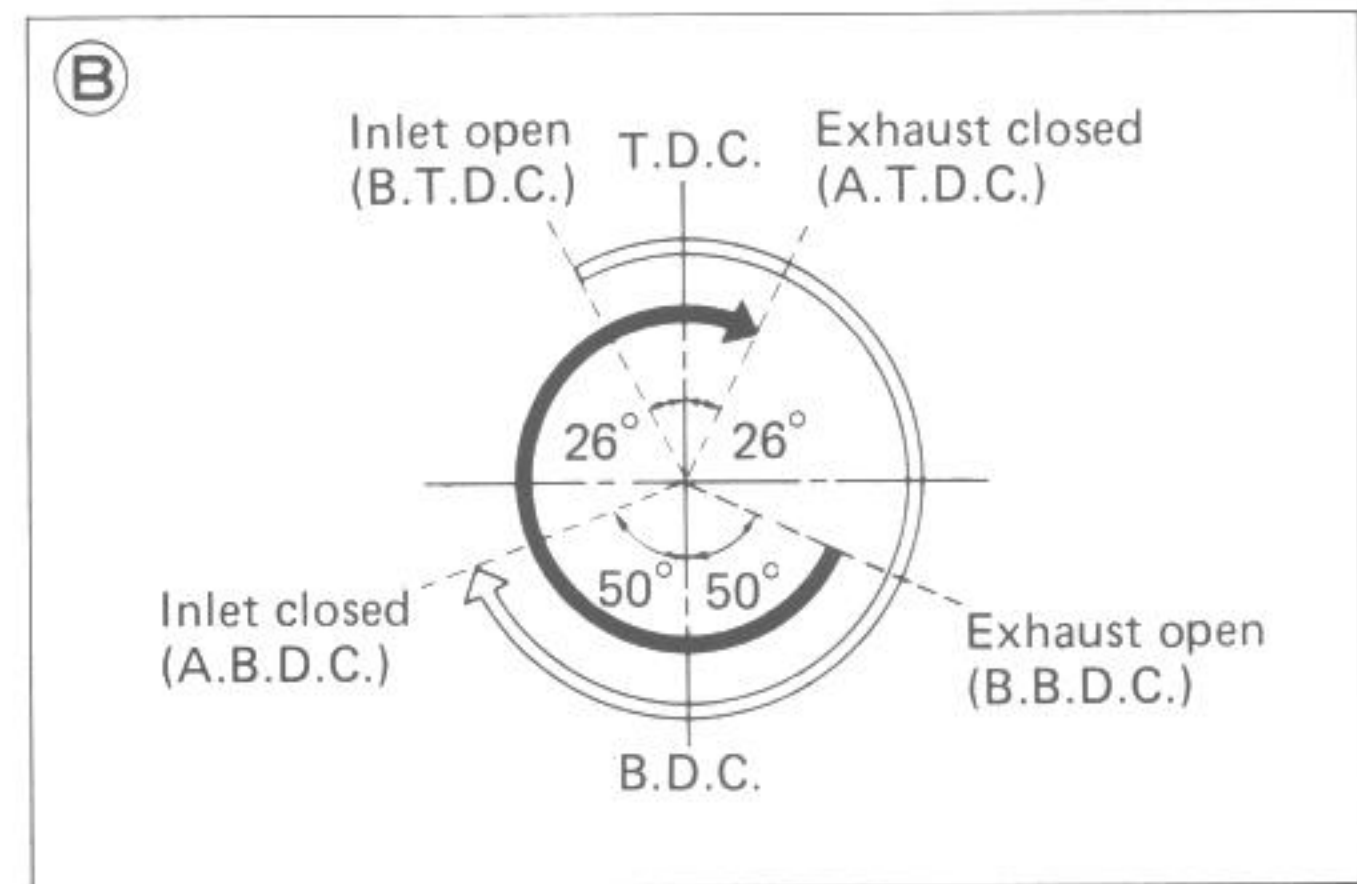
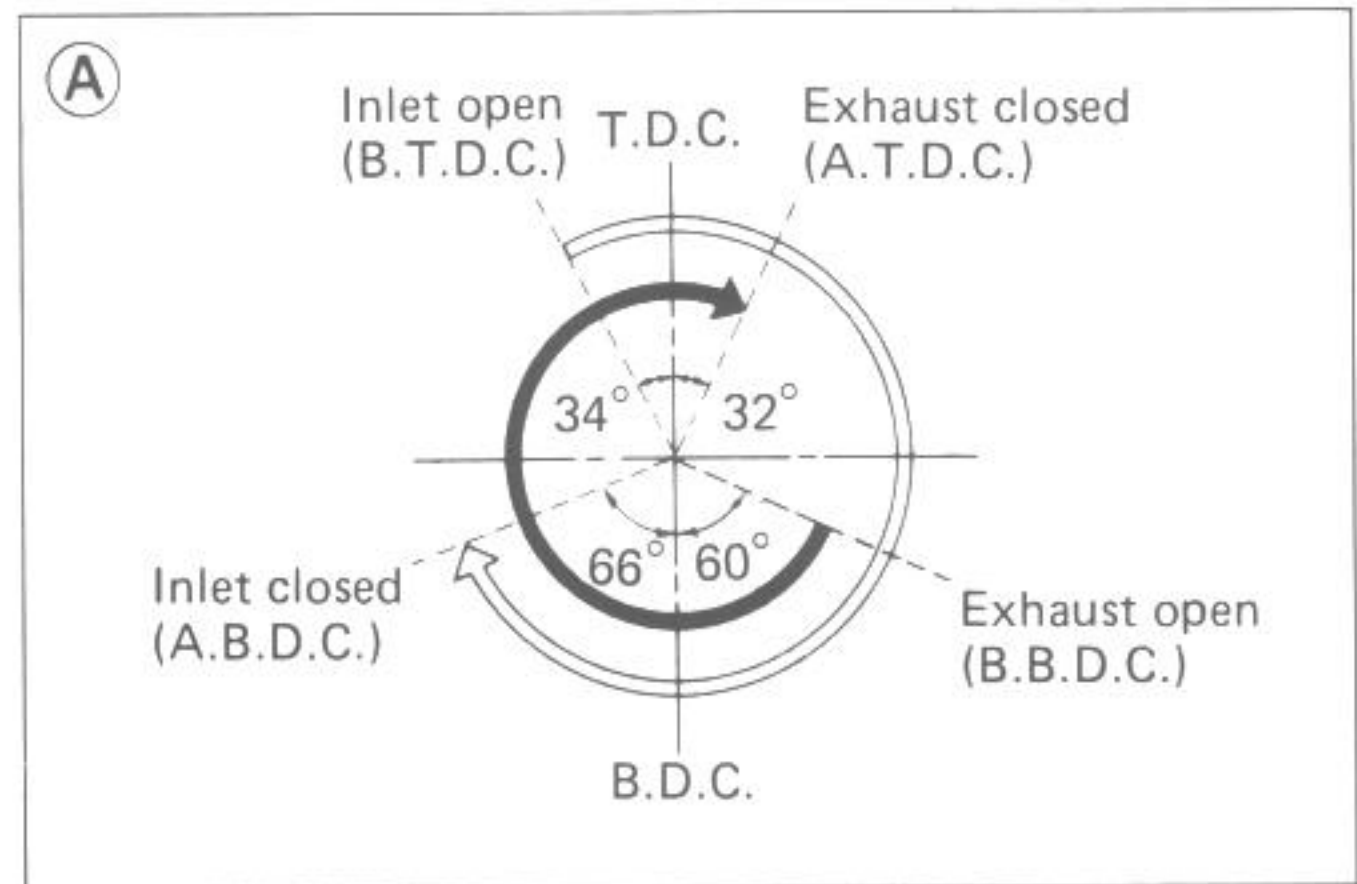

- The exhaust camshaft can be distinguished from that of the intake by the embossed letters "EX" (for exhaust) as against letters "IN" (for intake). The right end can be distinguished by the notch (1) at the right end of each camshaft.

CAM WEAR

- Worn-down cams are often the cause of mistimed valve operation resulting in reduced power output. The limit of cam wear is specified for both intake and exhaust cams in terms of cam height (H), which is to be measured with a micrometer. Replace camshafts if found worn down to the limit.

Cam height

	Height (H)	Service Limit
(A)	Intake cams	34.950 mm
	Exhaust cams	34.640 mm
(B)	Intake cams	34.360 mm
	Exhaust cams	34.060 mm

- (A) : General markets
- (B) : For Austria, Sweden, Switzerland and W. Germany

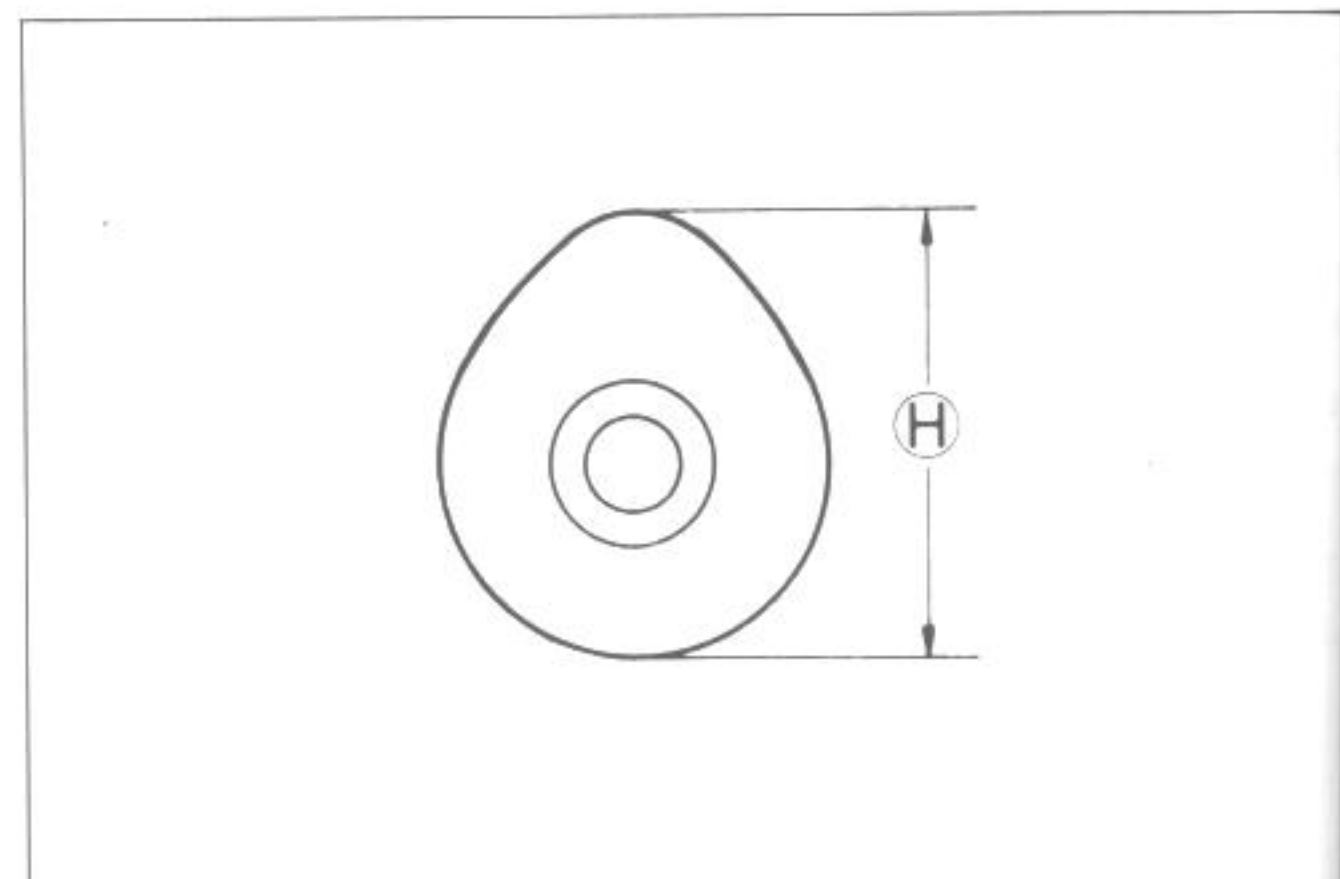
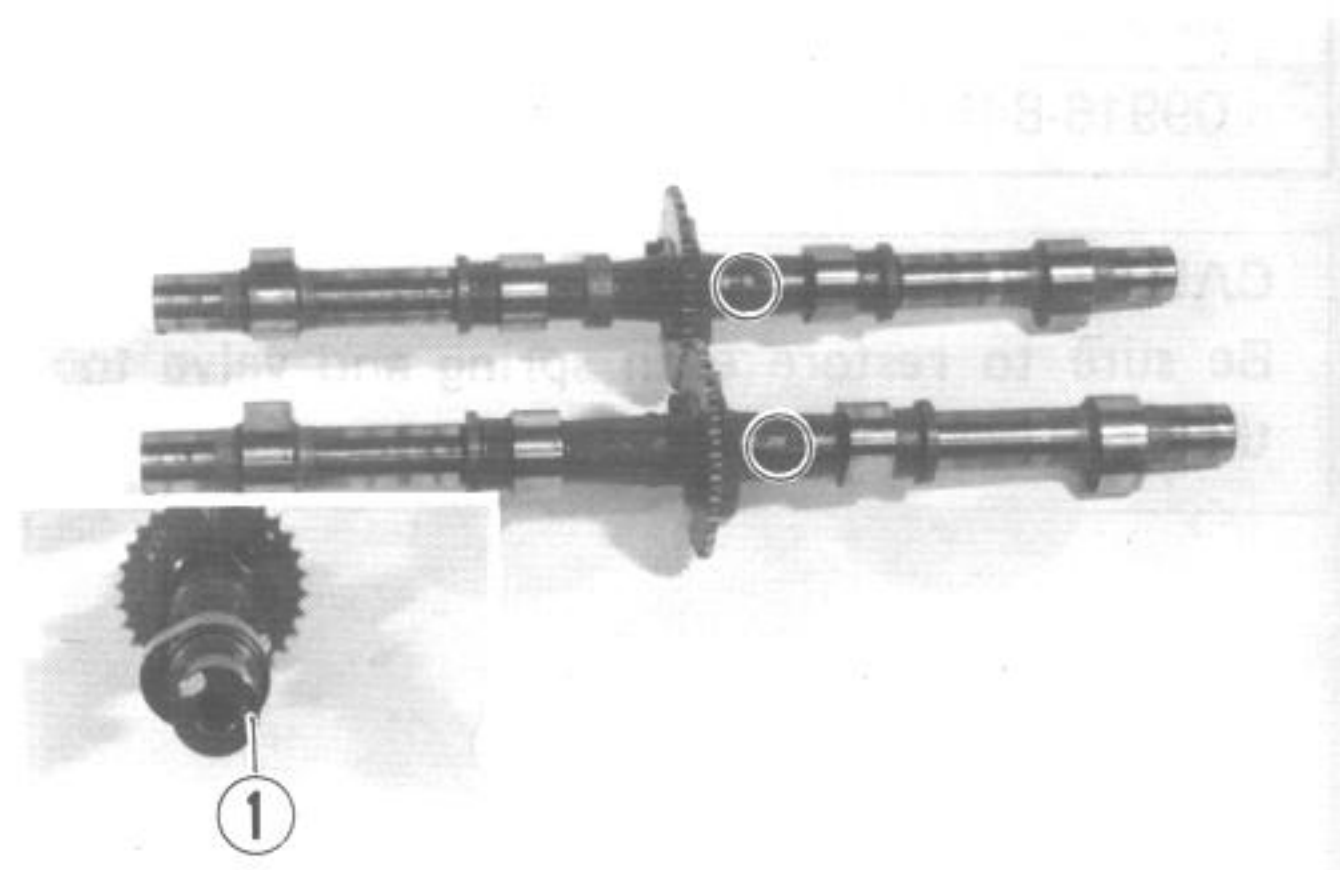

CAMSHAFT JOURNAL WEAR

- Determine whether each journal is worn down to the limit or not by measuring the running clearance with the camshaft installed in place. Use plastigauge ① to read the clearance at the widest portion, which is specified as follows:

Camshaft – Journal clearance

Service Limit	0.150 mm
---------------	----------

NOTE:

Install each holder to their original positions. Each holder has a cast on triangle. This triangle should be face forward.

09900-22301	Plastigauge
-------------	-------------

- Tighten the camshaft holder bolts evenly and diagonally to the specified torque.

Tightening torque	8 – 12 N·m (0.8 – 1.2 kg-m)
-------------------	--------------------------------

NOTE:

Do not rotate the camshafts with plastigauge in place.

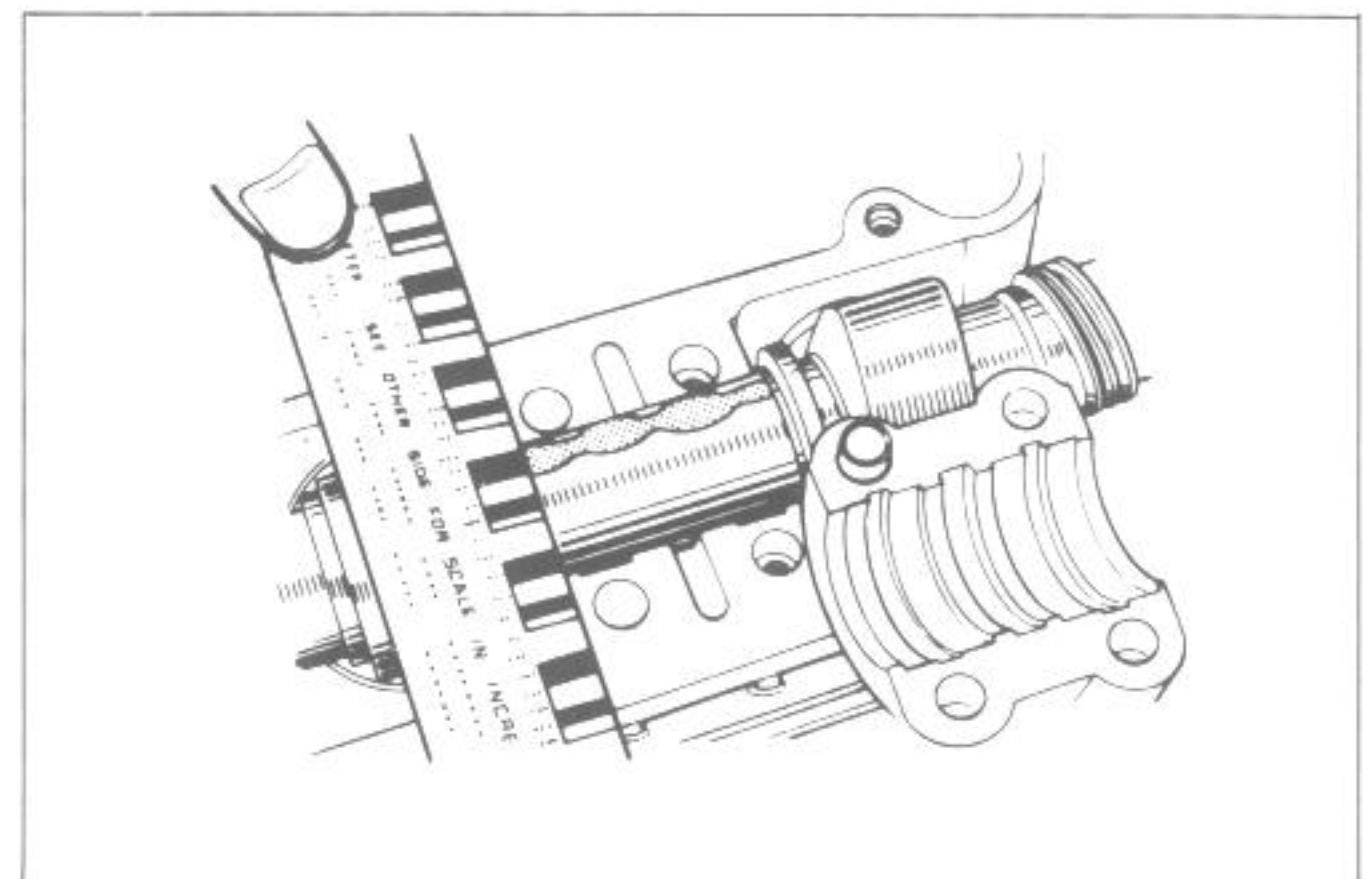
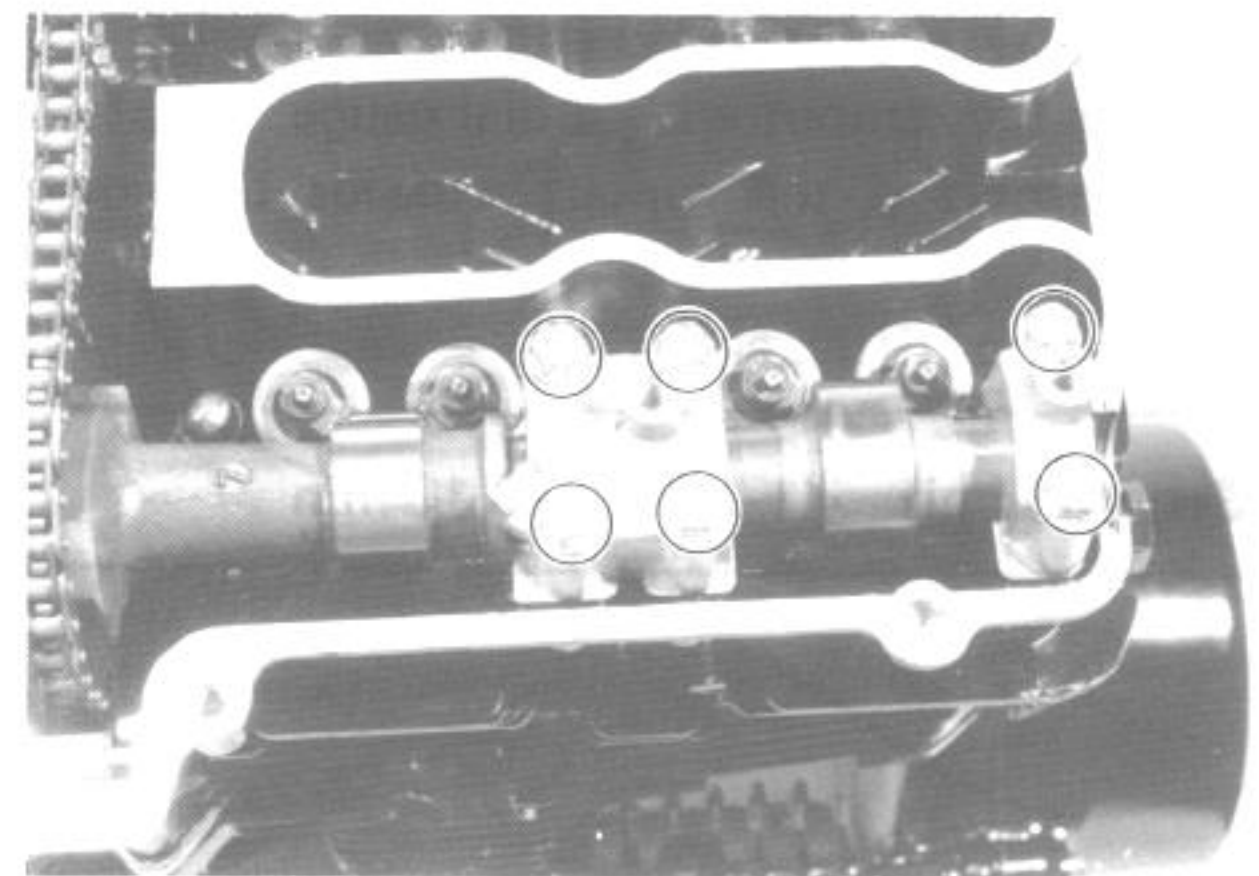
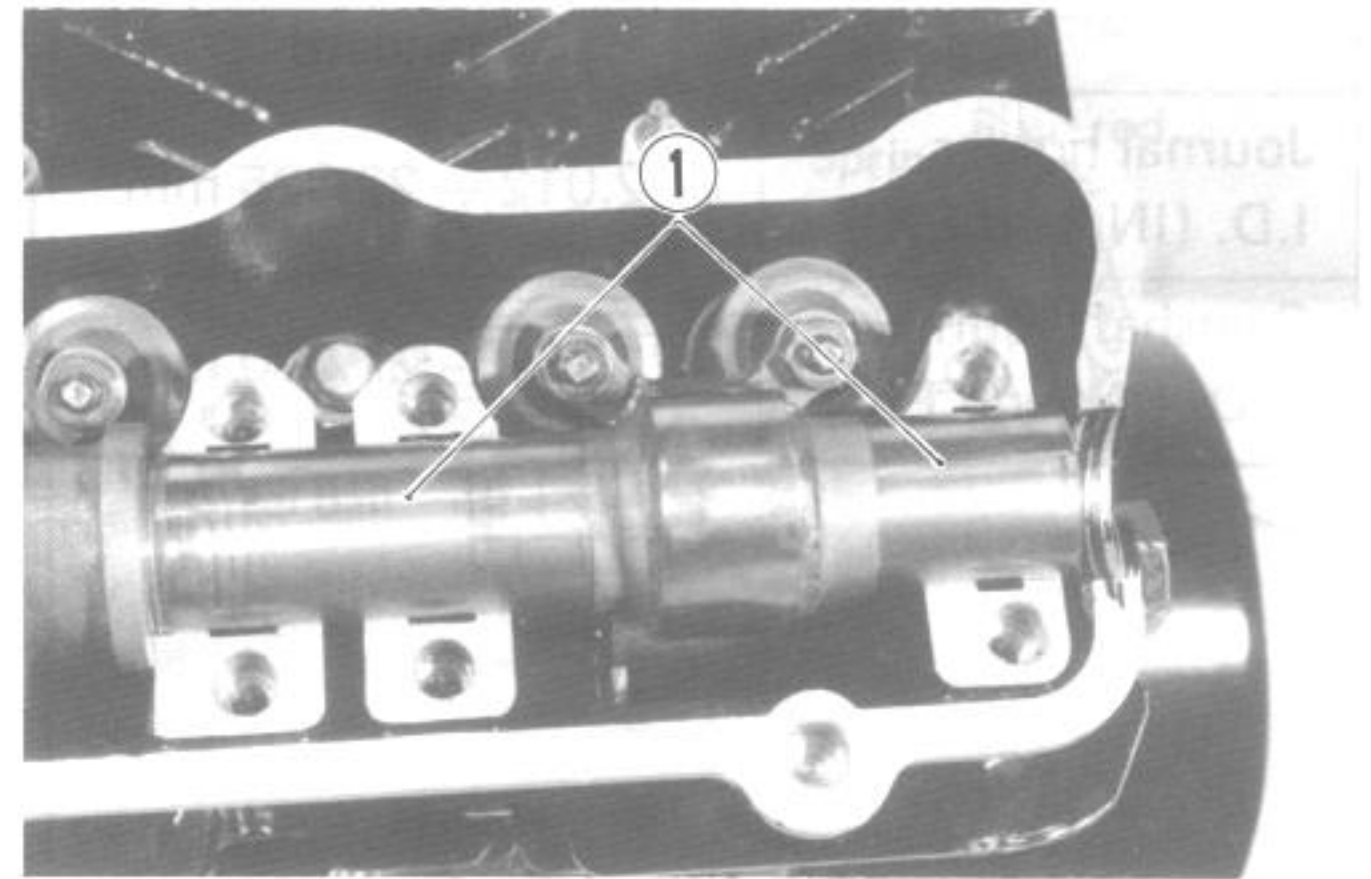

- If the camshaft journal clearance measured exceeds the limit, measure the inside diameter of camshaft bearing holder and outside diameter of the camshaft journal, whichever the difference from specification is greater.

09900-22403	Small bore gauge (18–35 mm)
09900-20205	Micrometer (0–25 mm)

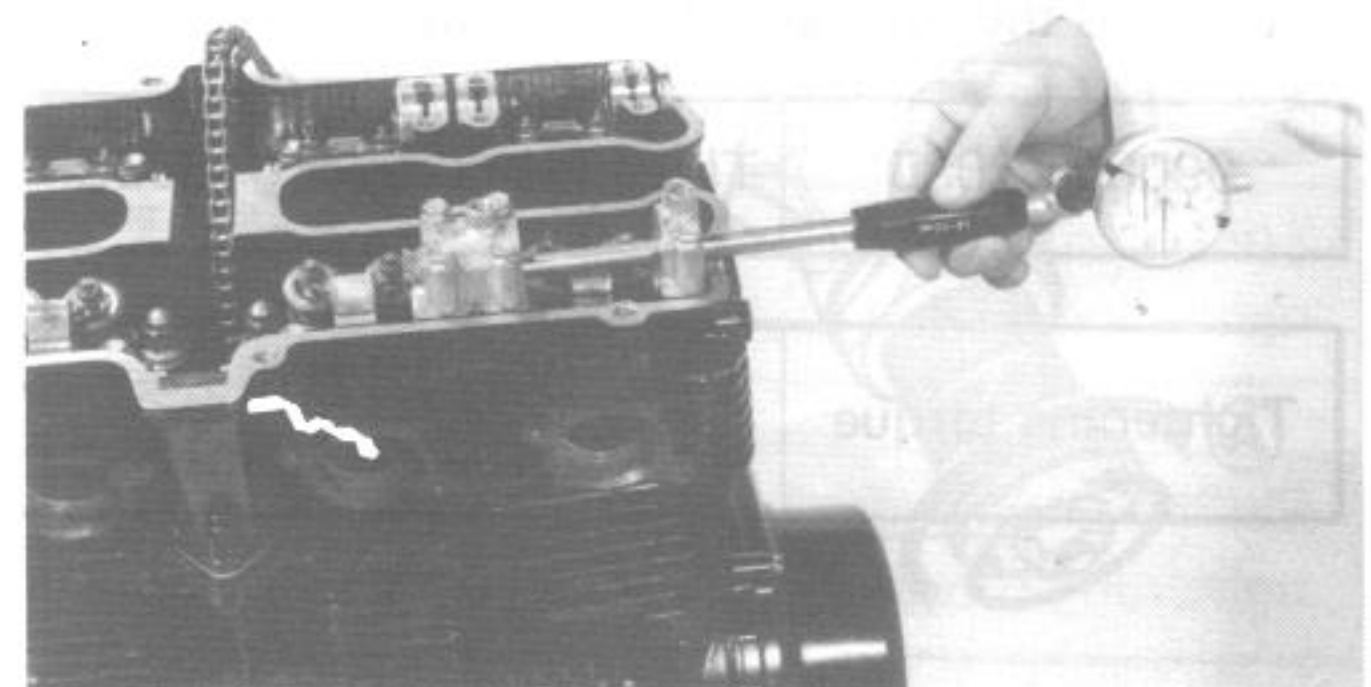

	Standard
Journal holder I.D. (IN. and EX.)	22.012 – 22.025 mm
Camshaft journal O.D. (IN. and EX.)	21.959 – 21.980 mm

CAMSHAFT RUNOUT

- Measure the runout with a dial gauge. Replace the camshaft if the runout exceeds the limit.

Camshaft runout (IN. and EX.)

Service Limit	0.10 mm
---------------	---------

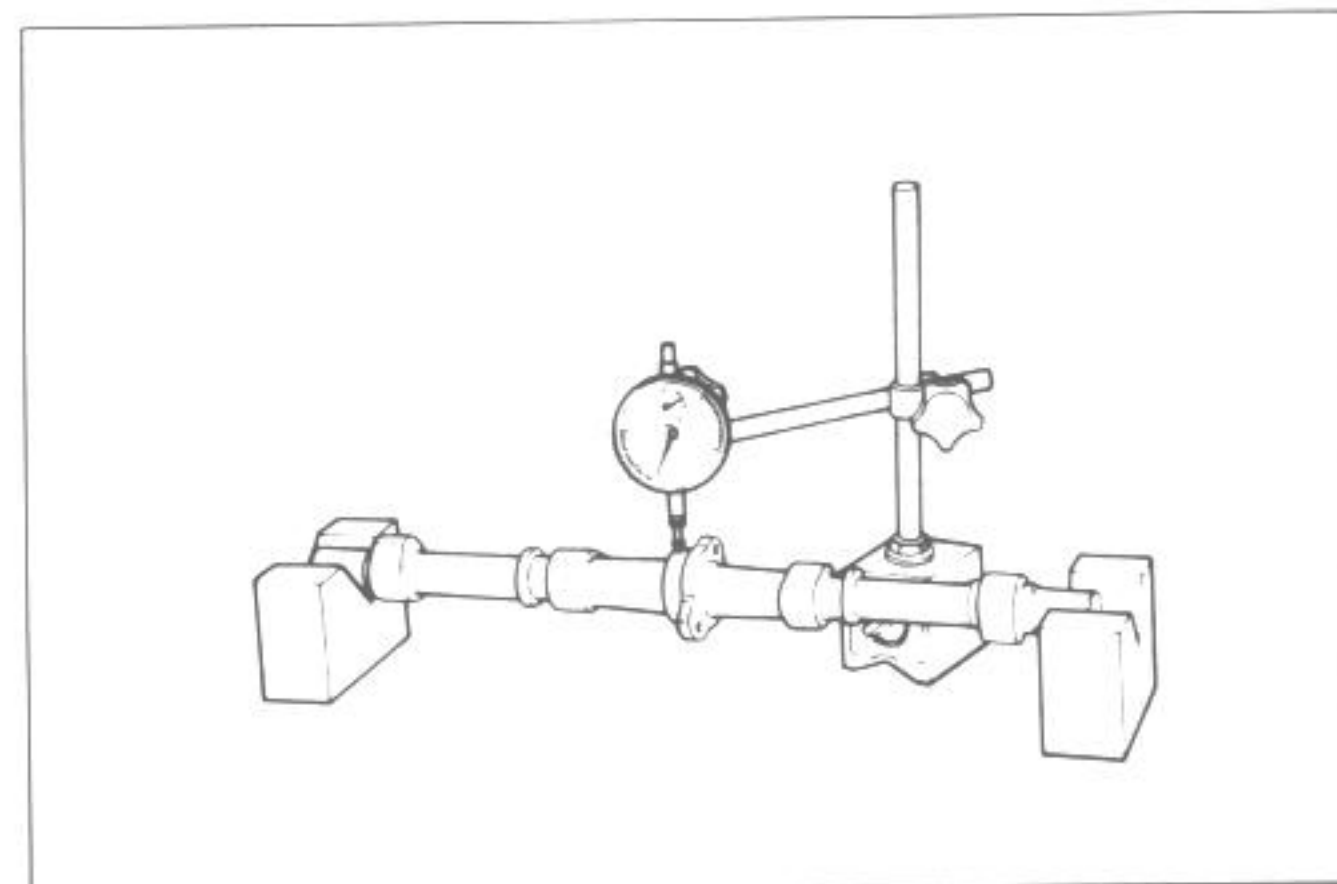
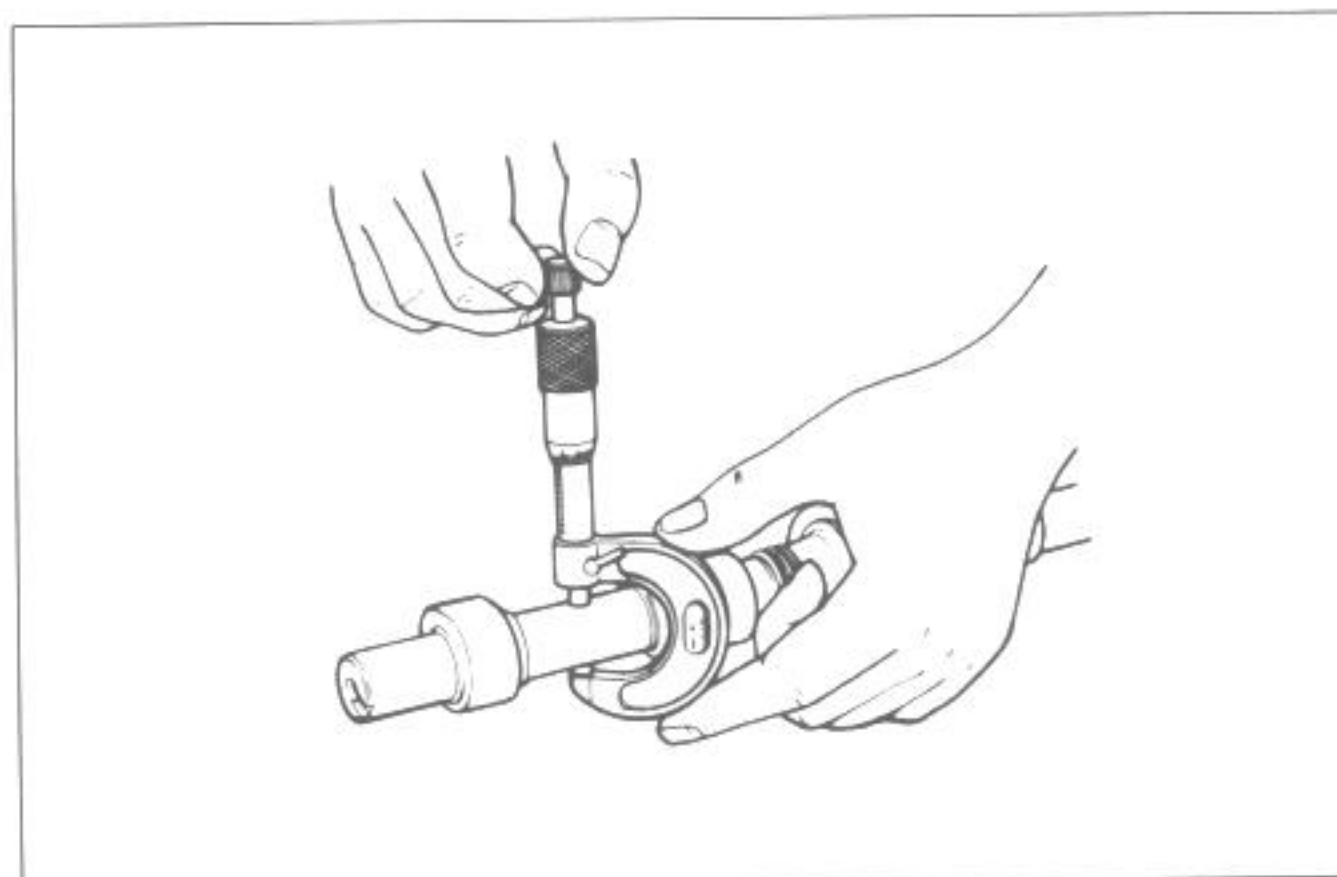

CAM SPROCKET REASSEMBLY

- It is very important that each sprocket be positioned on its camshaft as illustrated. Its correct position is determined by arrow mark "3" (on INTAKE sprocket) or arrow marks "1" and "2" (on EXHAUST sprocket) located (as shown) in reference to the notch ① in the camshaft end.

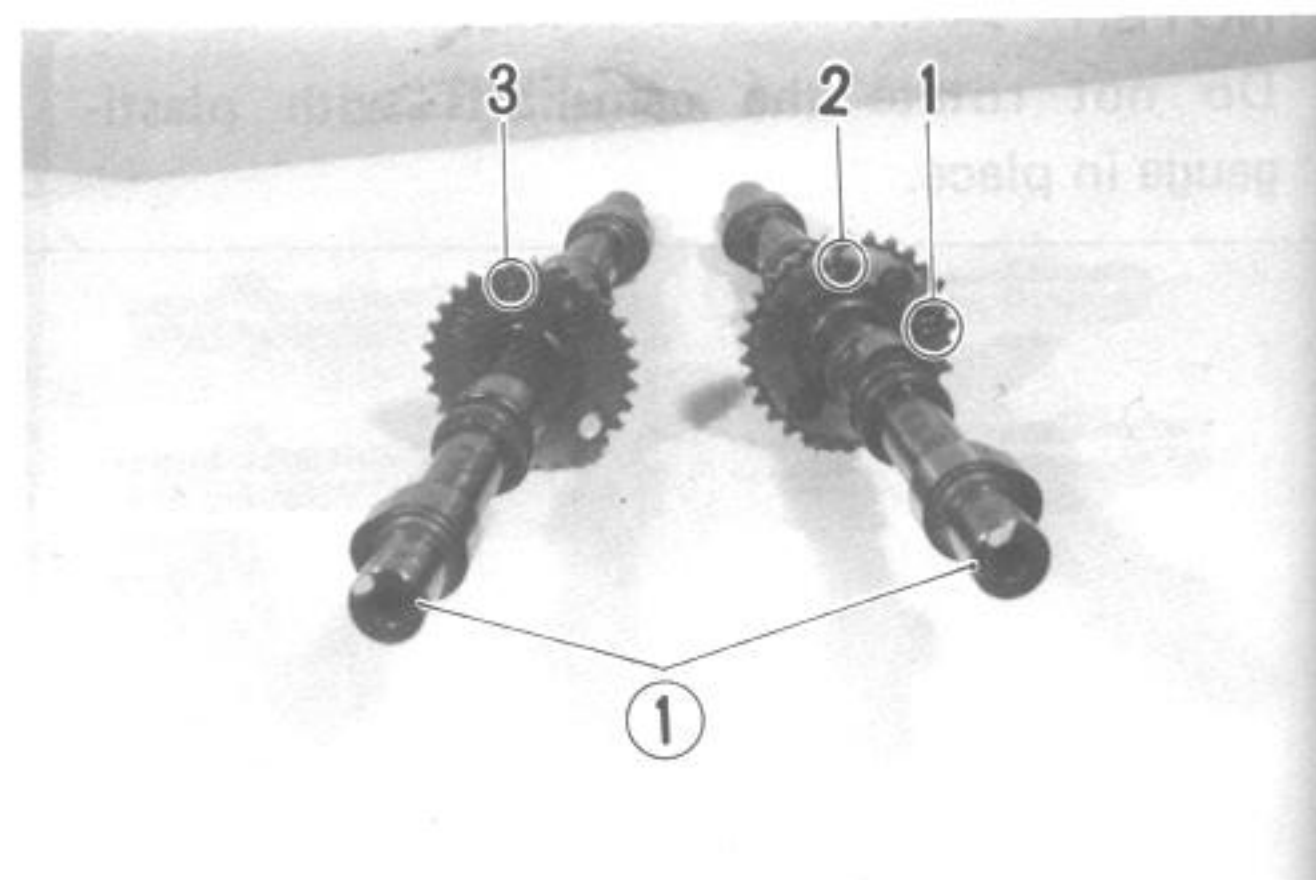

- Apply THREAD LOCK SUPER "1303B" to the threads of cam sprocket bolts, and tighten them to the following torque value:

99000-32030	Thread lock super "1303B"
-------------	---------------------------

Tightening torque	24 – 26 N·m (2.4 – 2.6 kg-m)
-------------------	---------------------------------

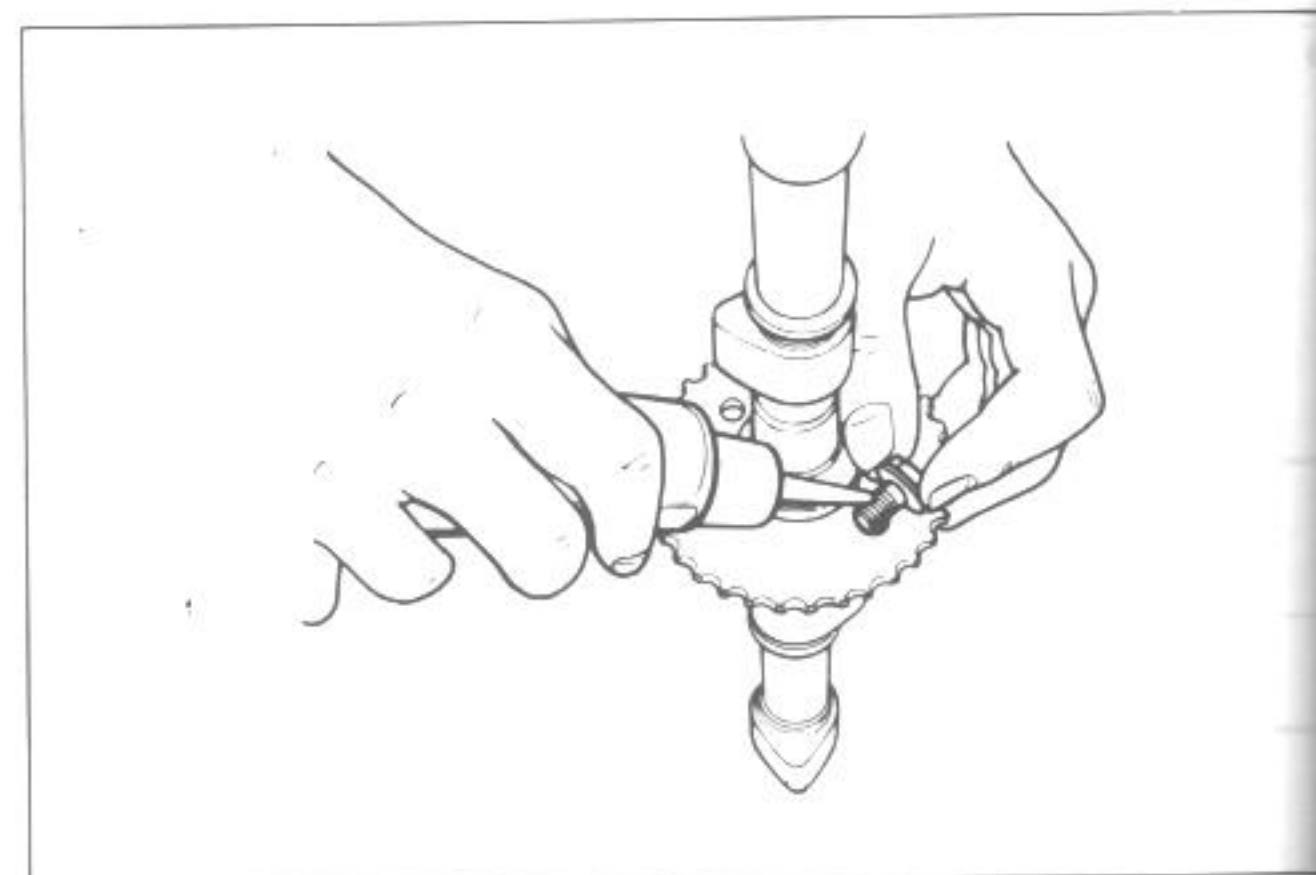

CA
DIS
• T
an
co
p
• T
p
st
in
at
fu
• T
te
vi
• W
sc

INS
• Tu
wi
mo
sli
ren
scr

• Tu
aga
it
ha
wi
Re
ces
act

CAM CHAIN TENSIONER DISASSEMBLY

- The tension adjuster used in this machine is an automatic type that adjusts itself to apply a constant tensioning force to the chain by compensating for the stretch of the chain.
- The spring-loaded pushrod exerts a constant pressure on the camshaft chain. As the chain stretches, it yields to this pressure and remains in a state of tension. Once the adjuster is set after installation, there is no need to make any further adjustment.
- The pushrod effectively contends with the tendency of the camshaft chain to shake or vibrate during rough driving conditions.
- While pushing the push rod, loosen the lock screw and extract the push rod.

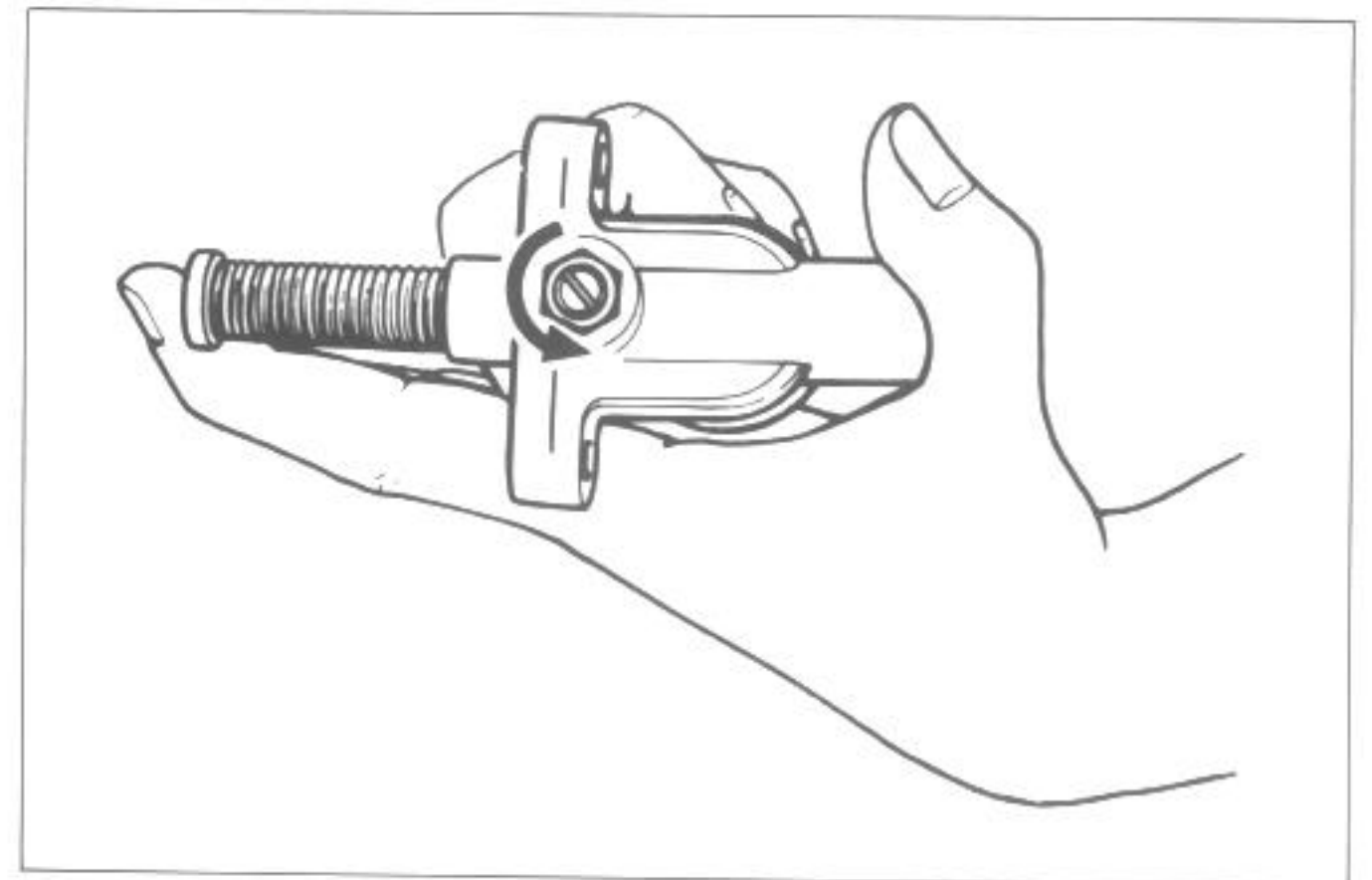
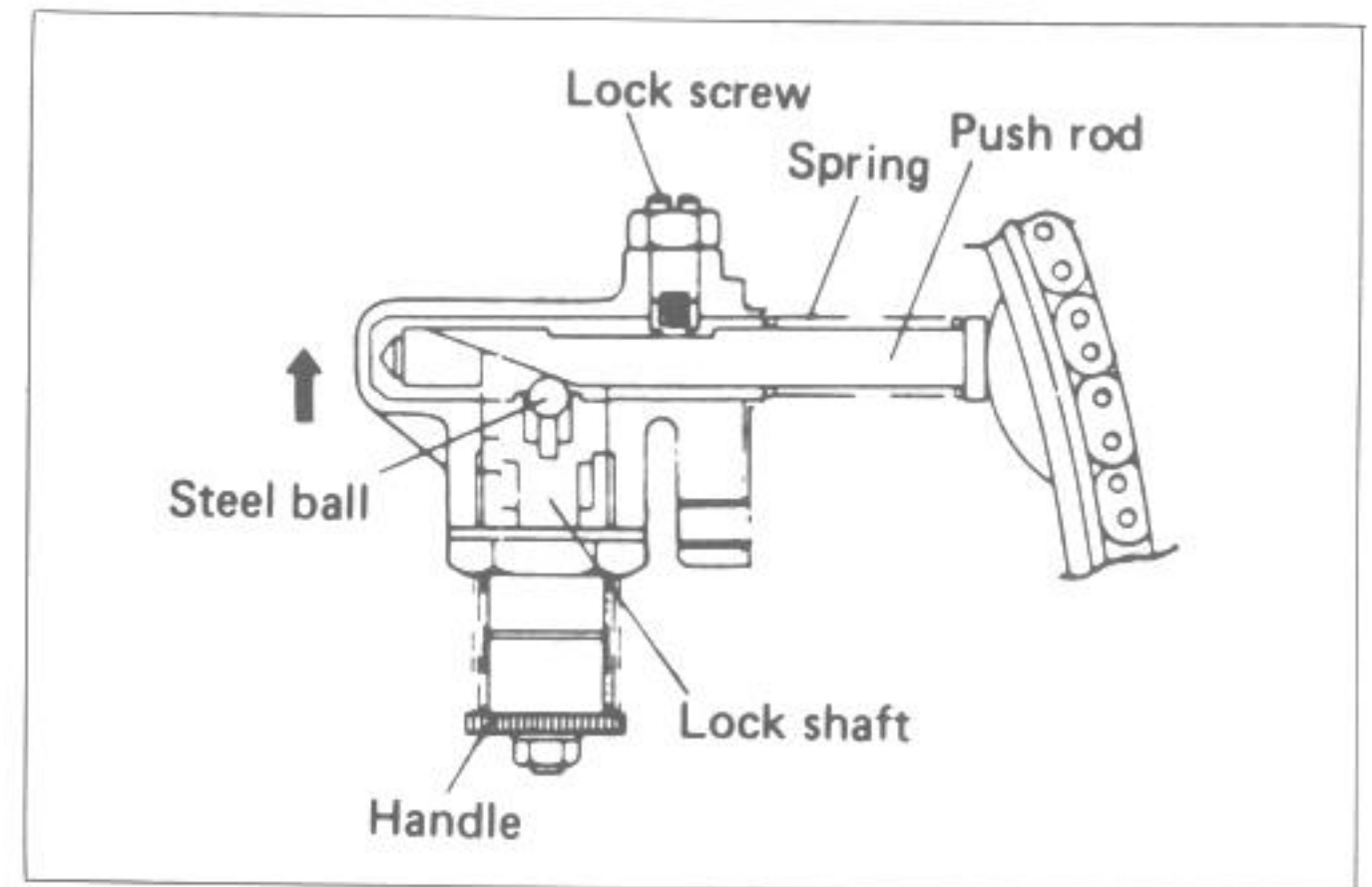

INSPECTION

- Turn the handle ① all the way counterclockwise after loosening the lock screw ②, and move the push rod ③ in place to see if it slides smoothly. If any stickiness is noted, remove the rod for inspection. A bent or scratched push rod must be replaced.
- Turn handle ③ all the way counterclockwise against the force of its coil spring and then turn it back as assisted by spring force to see if the handle returns to the original position ④ without exhibiting any sticking on the way. Repeat this process several times. If any excessive sticking is felt or if the self-adjusting action is faulty, replace the whole tensioner.

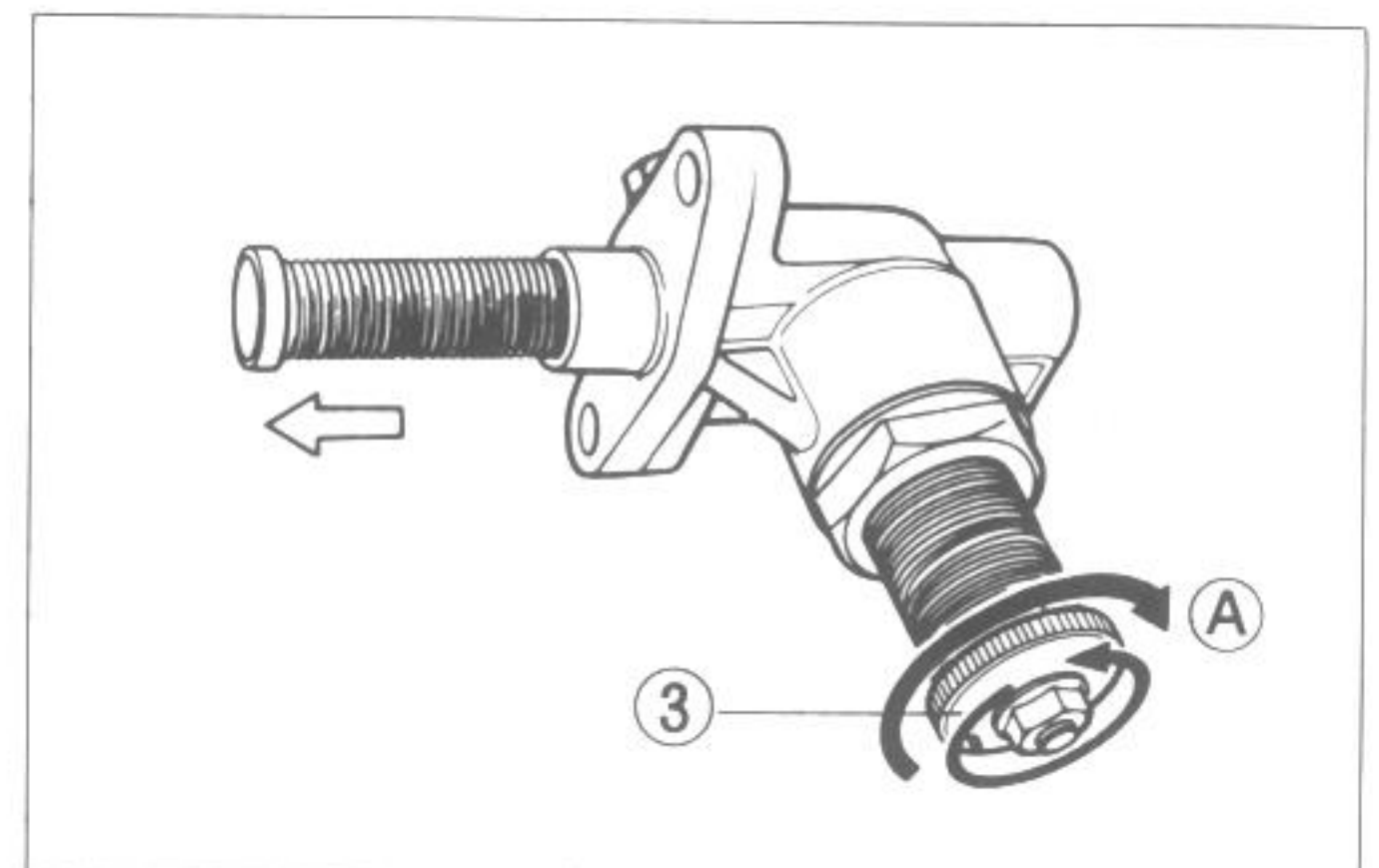
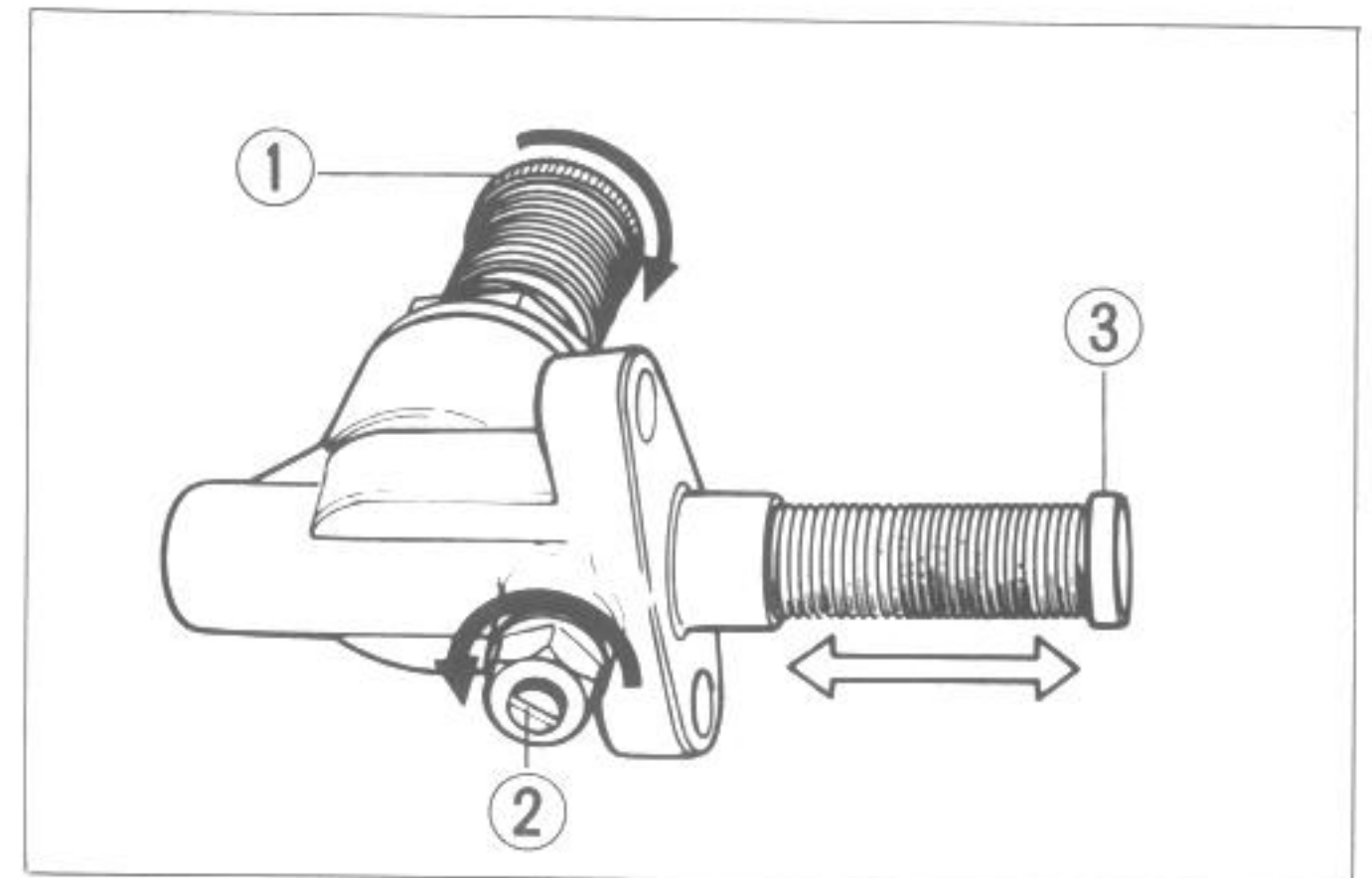

REASSEMBLING

- Apply engine oil to the lock shaft ①. Insert the shaft into the holder ② and bring the two into the relative position indicated.

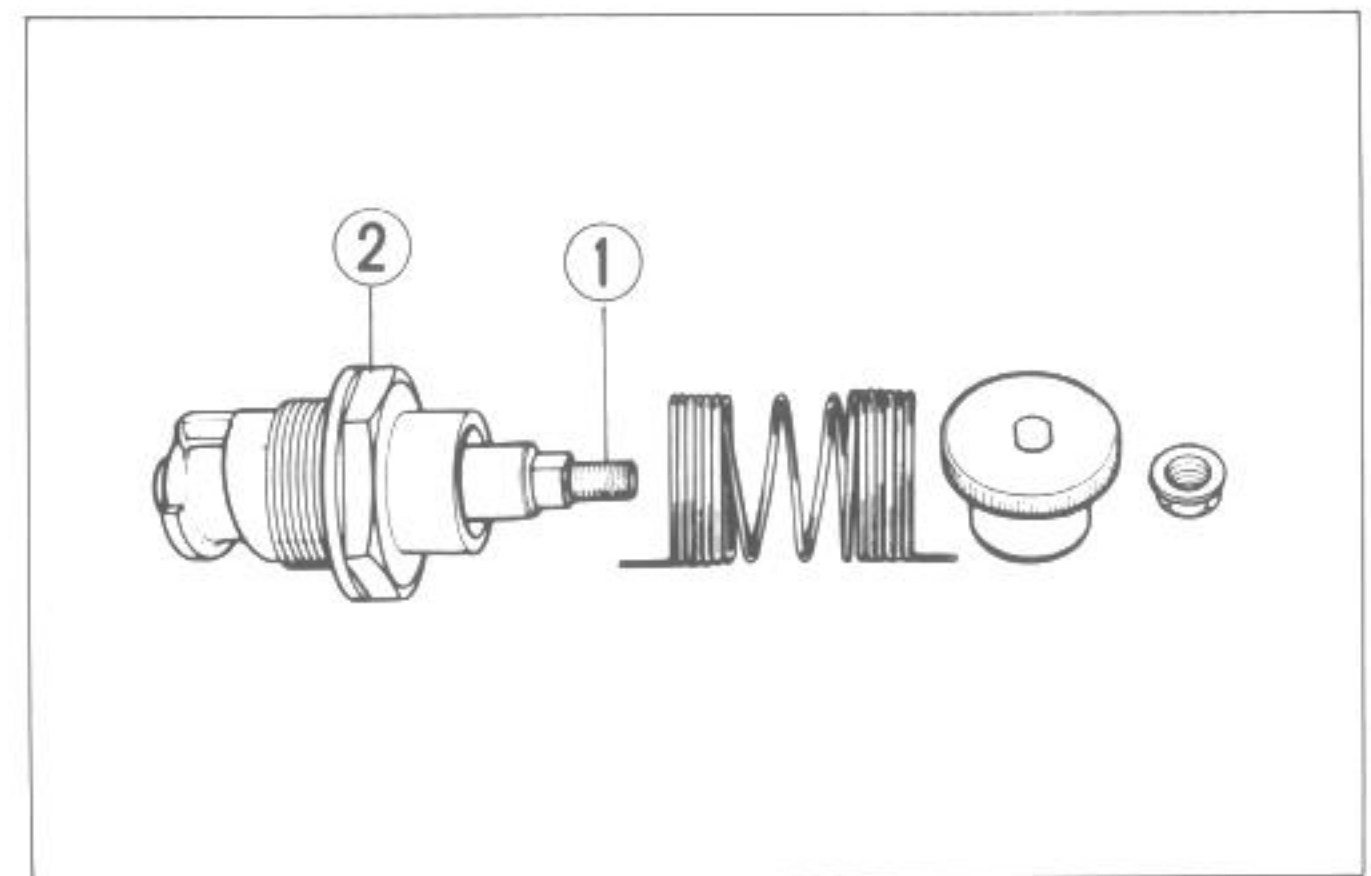
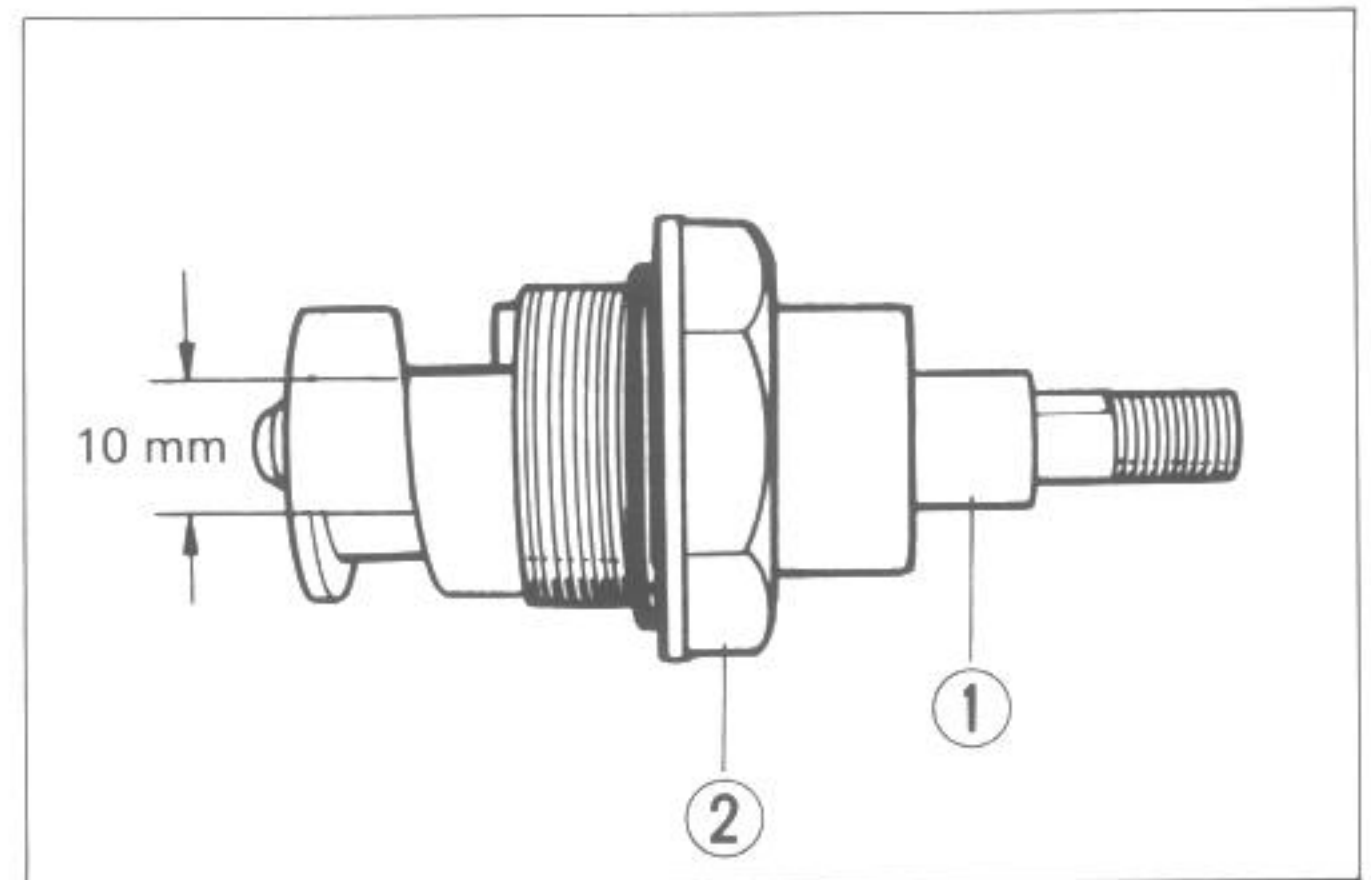

- Hook the spring onto the holder and handle ③, twist the spring by one complete rotation counterclockwise (A), fit the handle onto the shaft, and then install the nut ④.

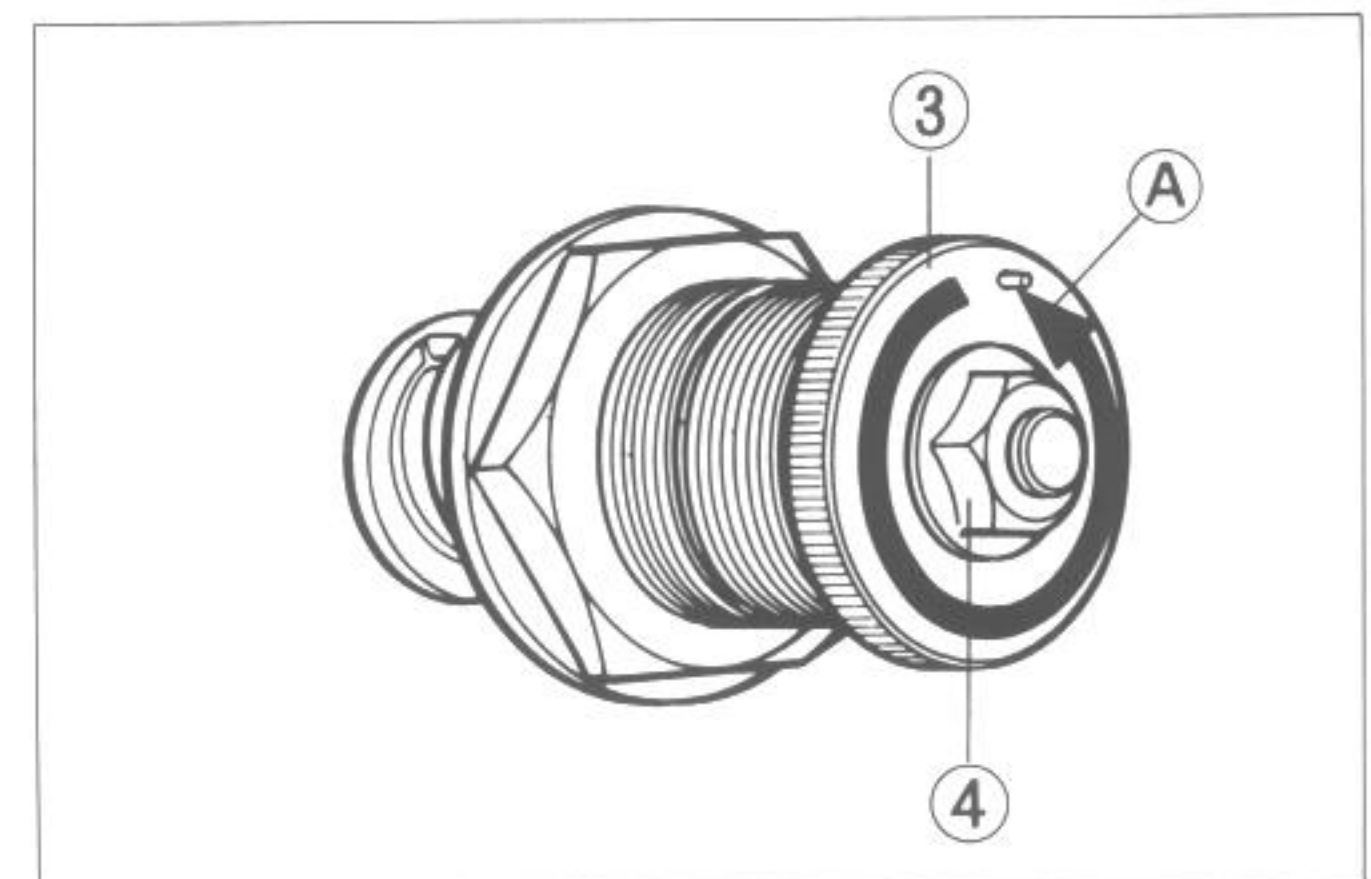

- After tightening the lock shaft nut ④, install the lock shaft assembly ⑤ on the tensioner body ⑥. Be sure to adhere to the following torque specifications:

Lock shaft nut ④ tightening torque	8 – 10 N·m (0.8 – 1.0 kg-m)
---------------------------------------	--------------------------------

Shaft assembly ⑤ tightening torque	30 – 35 N·m (3.0 – 3.5 kg-m)
---------------------------------------	---------------------------------

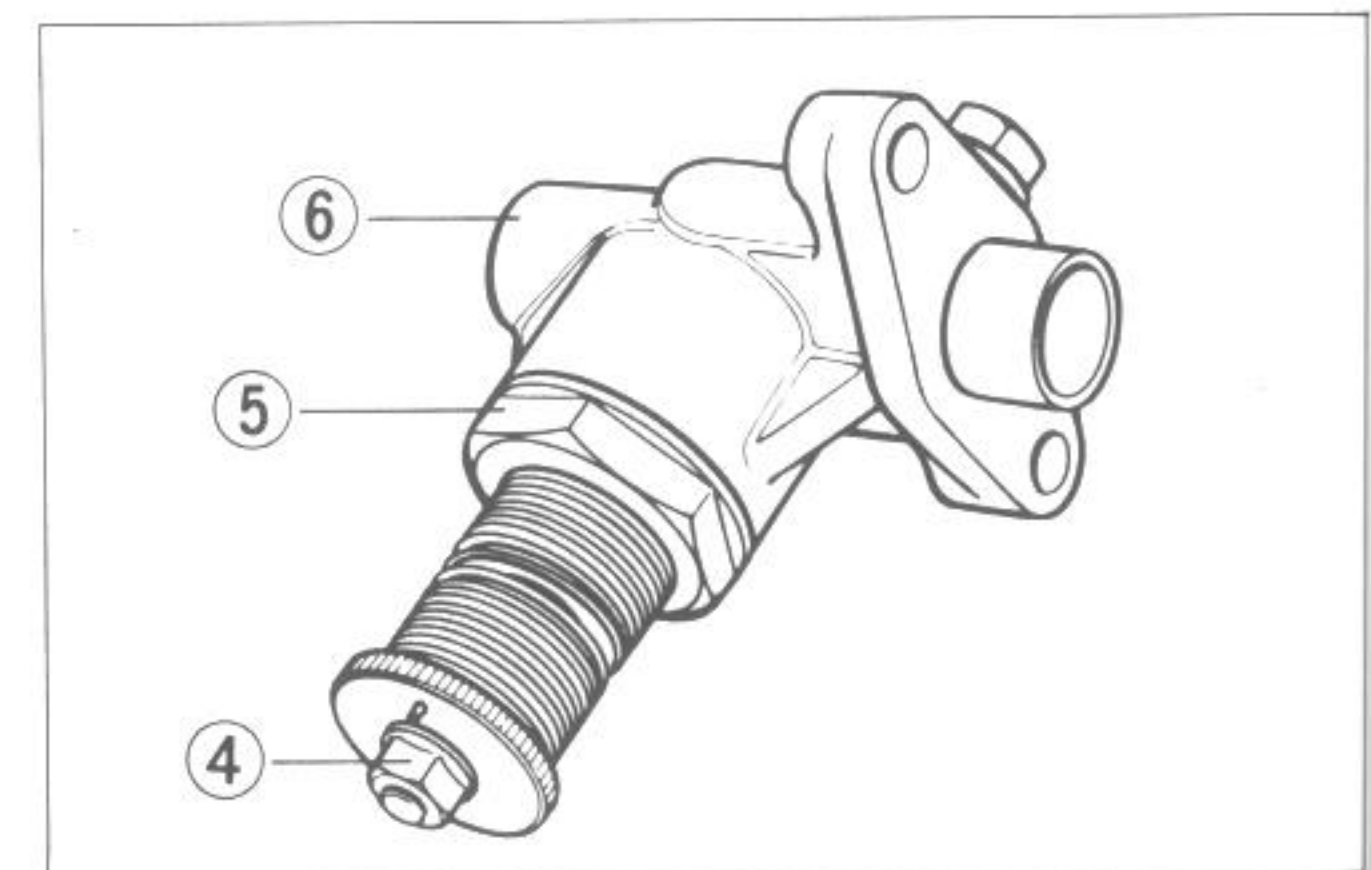

- Apply a high quality molybdenum disulfide lubricant (SUZUKI MOLY PASTE) to the push rod and engine oil to the push rod guide hole.

99000-25140

SUZUKI Moly Paste

- Match the lock screw hole ① to the long groove ② in the push rod, as shown.
- Slide the pushrod spring onto the pushrod.

- While turning lock shaft handle counterclockwise, push in the pushrod all the way. Keep on turning the handle until it refuses to turn further.

- Tighten the lock screw to lock the pushrod, so that the pushrod will not plunge out.

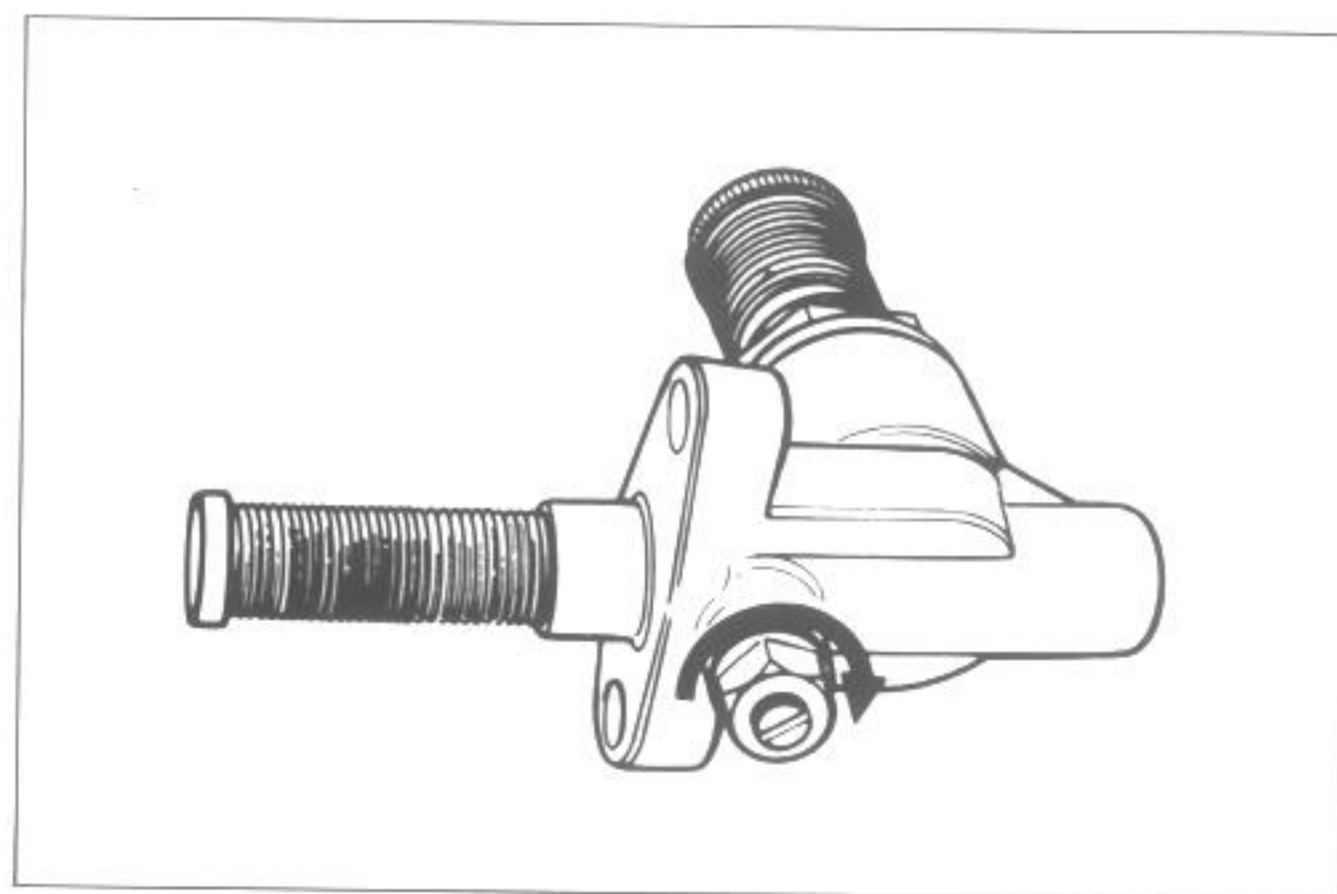
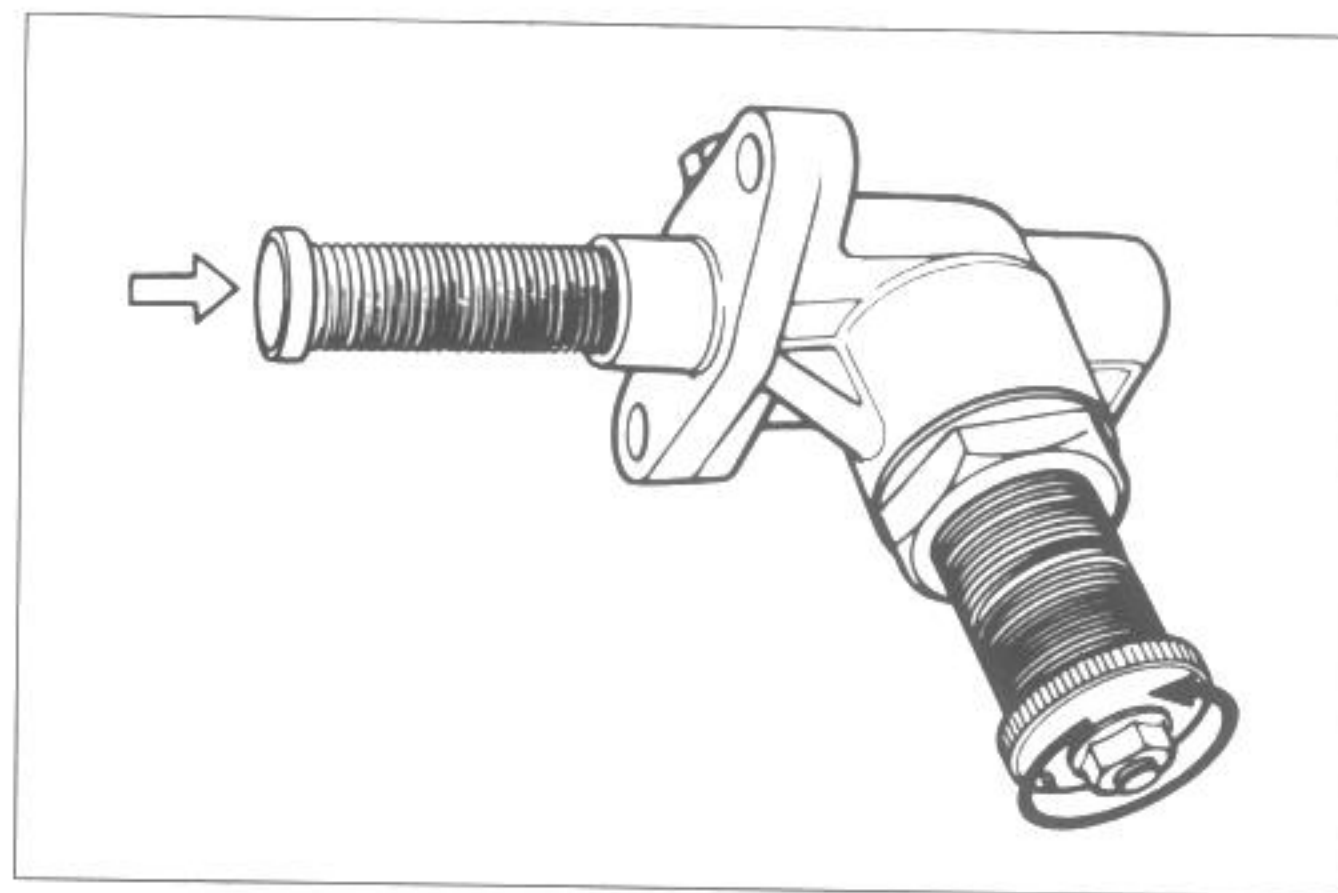
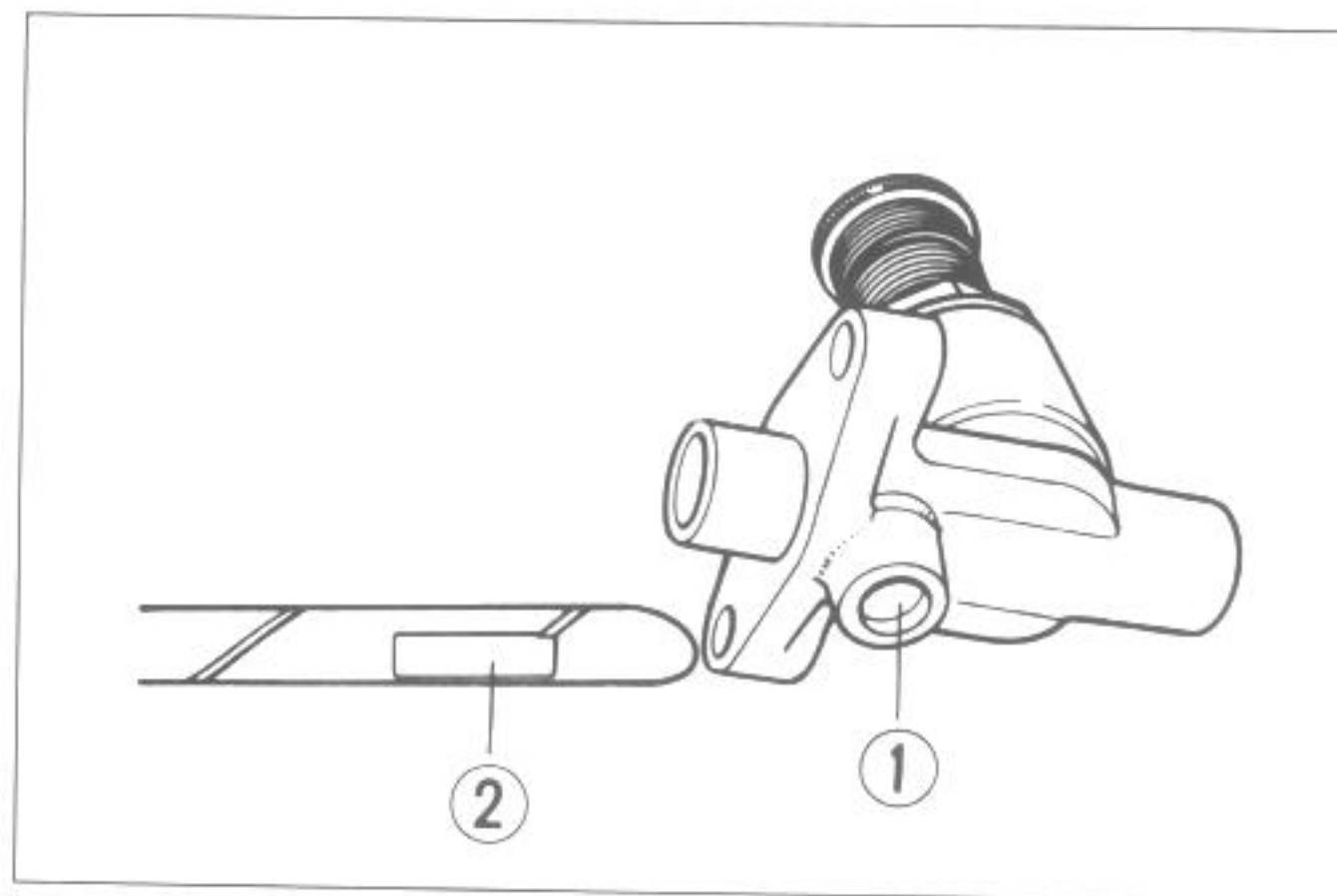
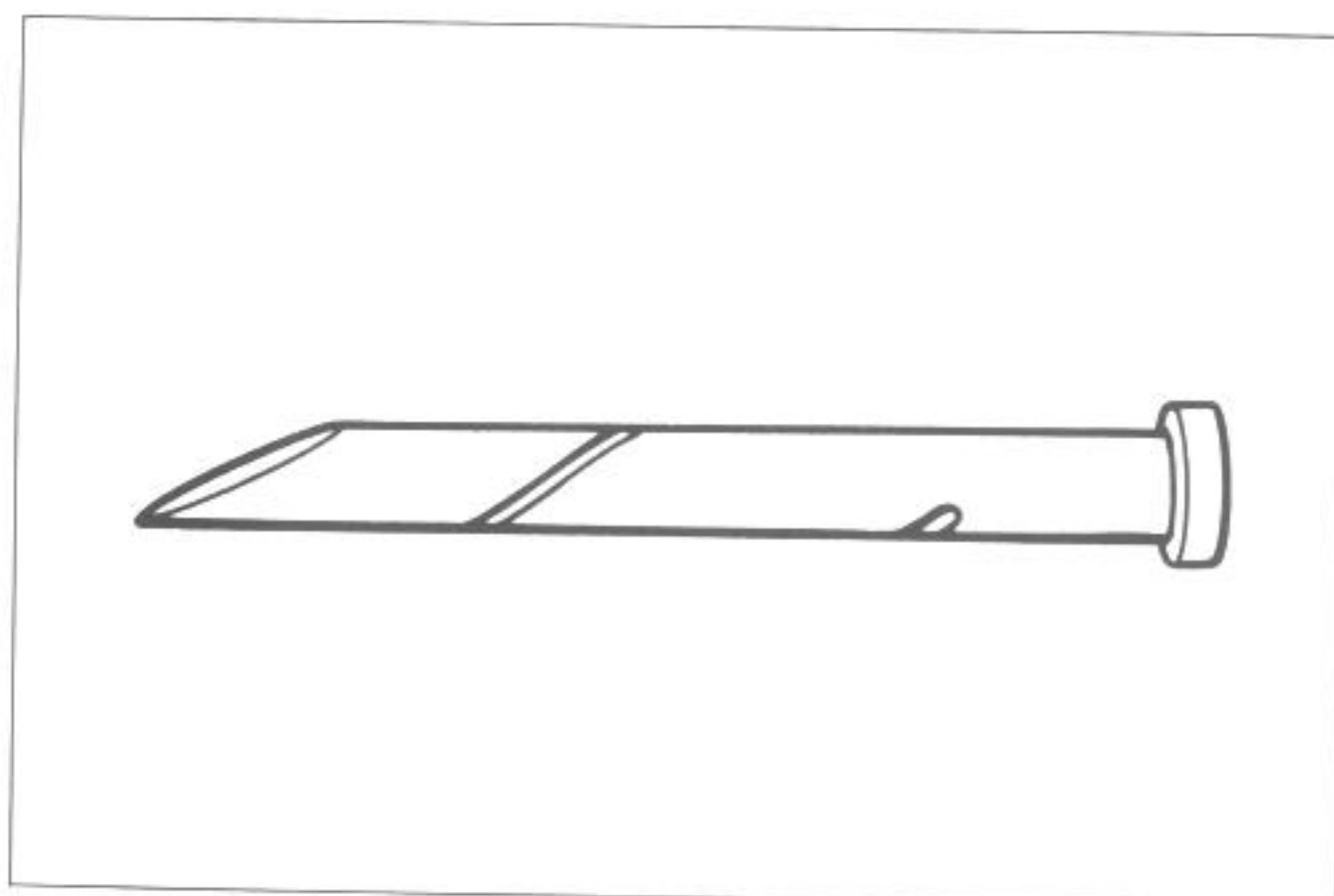

CAM CHAIN 20-PITCH LENGTH

Pull the chain tight to remove any slack, then using vernier calipers, measures the 20-pitch length of cam chain. If it measures more than limits, replace the cam chain.

Service Limit	157.8 mm
---------------	----------

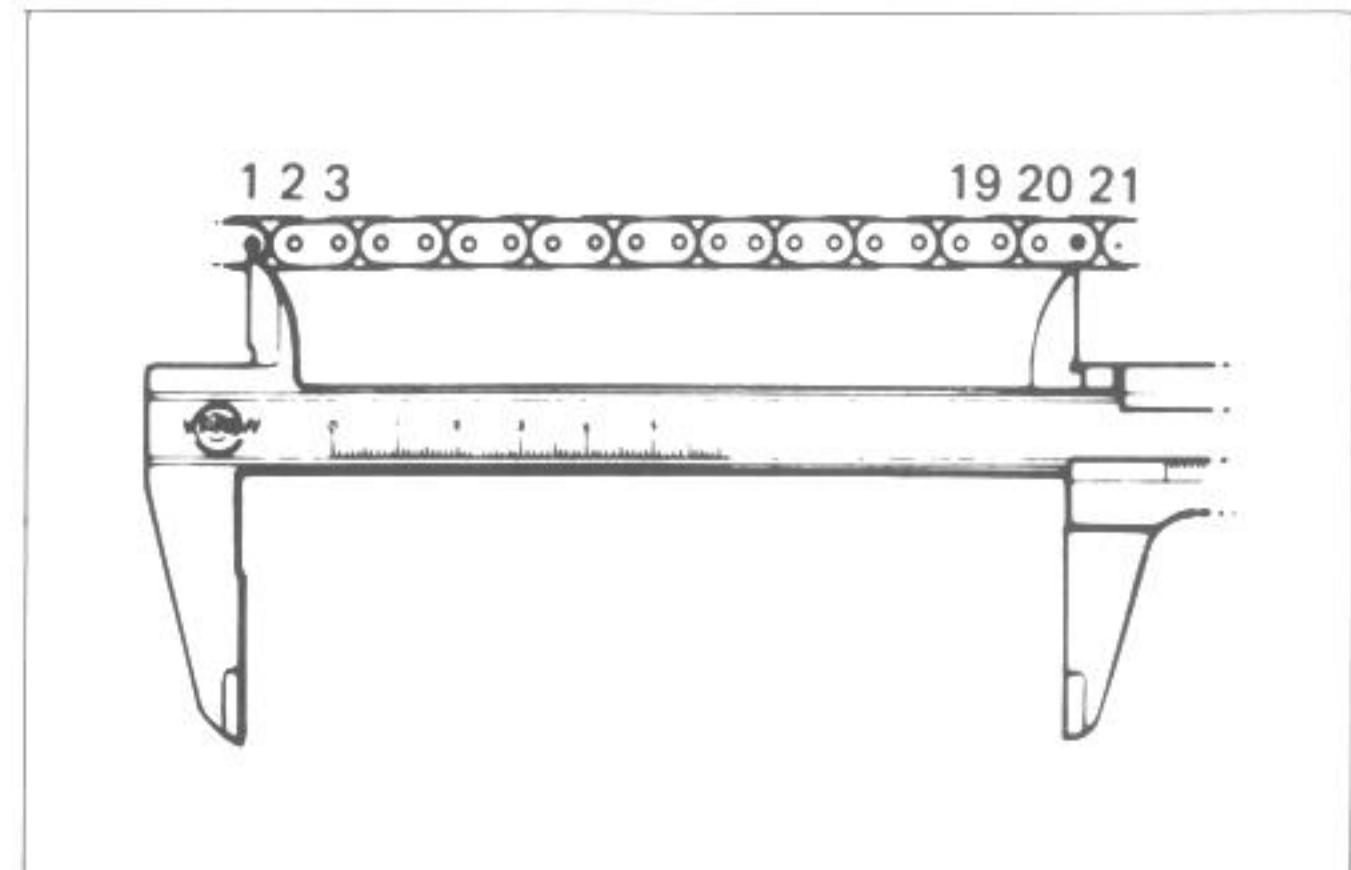

CAM CHAIN GUIDE

NOTE:

When replacing following chain guides, apply SUZUKI Thread lock super "1333B" to screws thread.

99000-32020	Thread lock super "1333B"
-------------	---------------------------

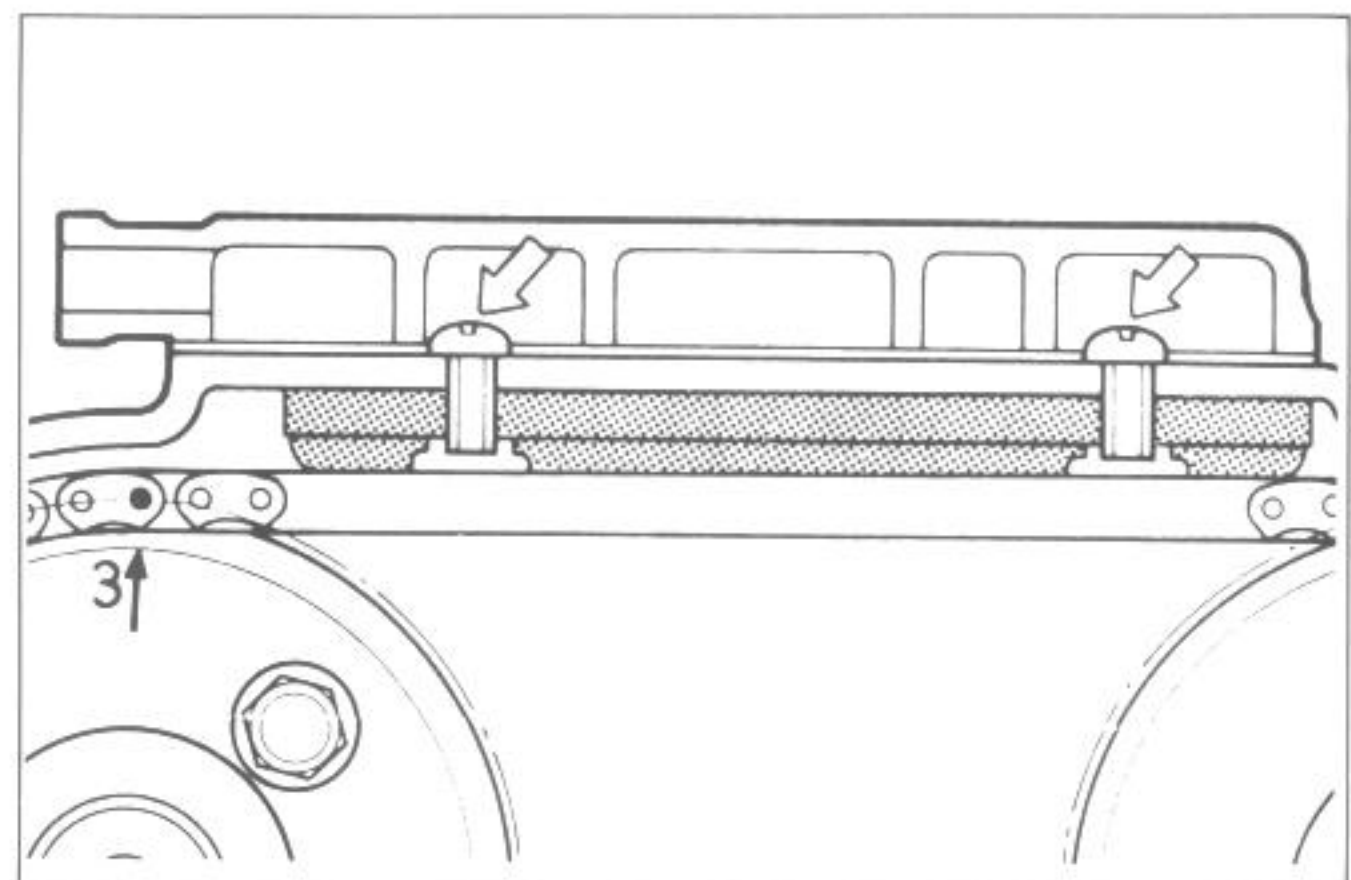

CYLINDER DISTORTION

Check the gasketed surface of the cylinder for distortion with a straightedge and thickness gauge, taking a clearance reading at several places indicated. If the largest reading at any position of the straightedge exceeds the limit, replace the cylinder.

Cylinder distortion

Service Limit	0.20 mm
---------------	---------

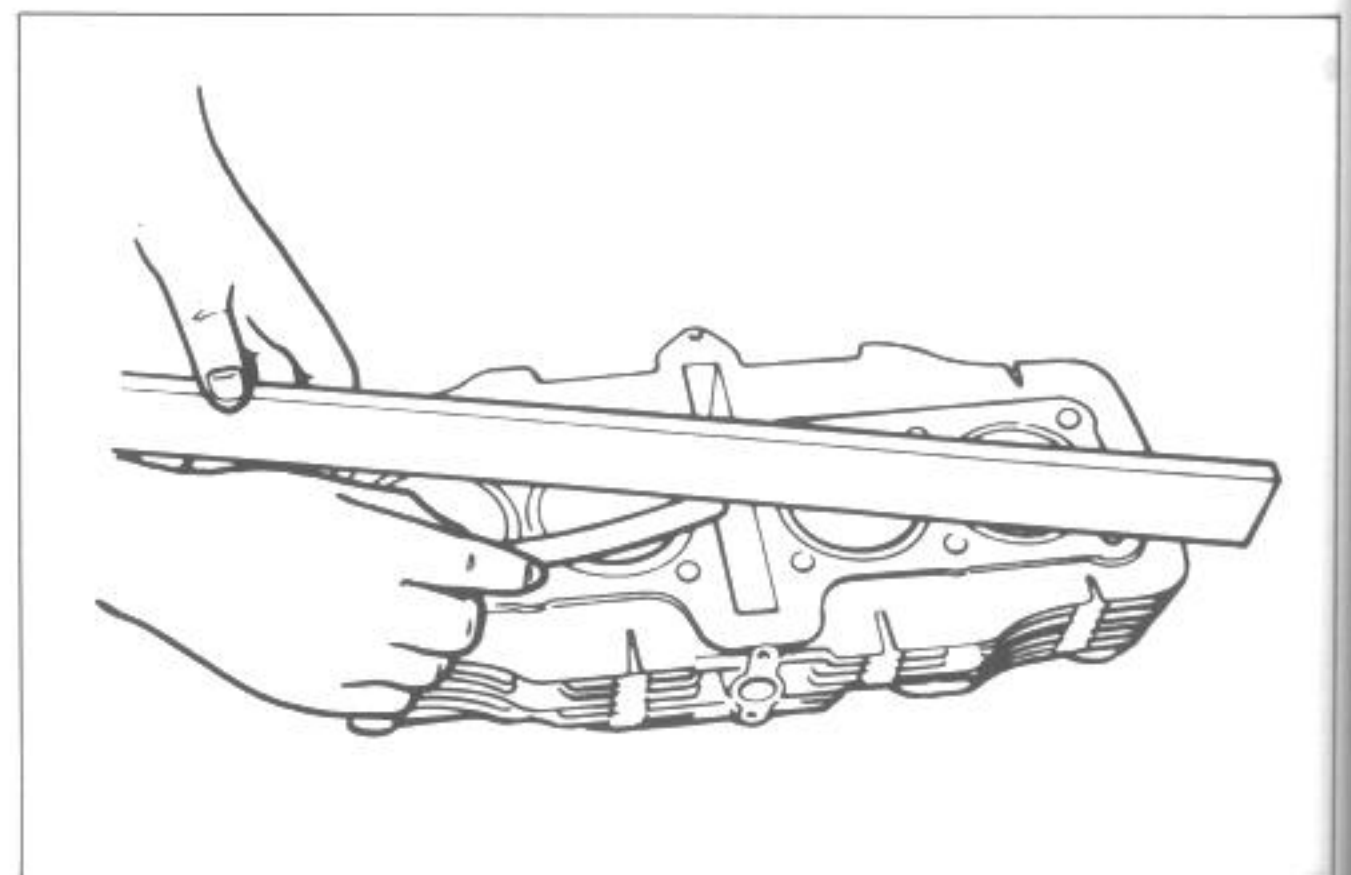
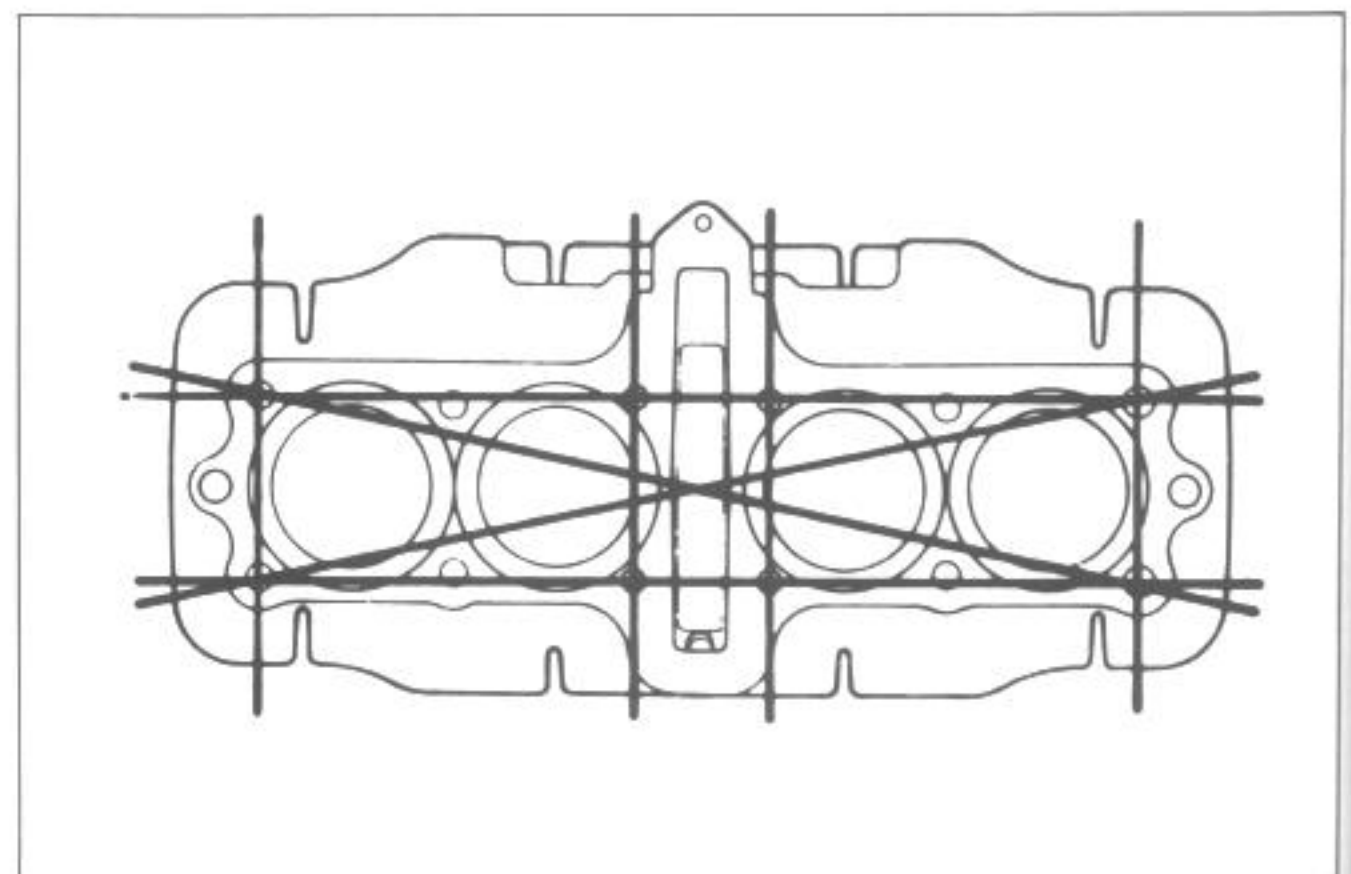

CYLINDER

Measure...
If any...
overhaul...
an overhaul...
If one...
go over...
same...
excess...

Cylinder

Service

09

Overhaul

Just

size

PISTON

Using a...
diameter...
surement...

Piston

Service

099

PISTON

As a...
piston...
overhaul...
or repla...

Service

CYLINDER BORE

Measure the cylinder bore diameter at six places. If any one of the measurements exceeds the limit, overhaul the cylinder and replace the piston with an oversize, or replace the cylinder.

If one cylinder is worn to the point that it needs to go oversize, all cylinders should go oversize at the same time. Otherwise the imbalance might cause excess vibration.

Cylinder bore

Service Limit	74.080 mm
09900-20508	Cylinder gauge set

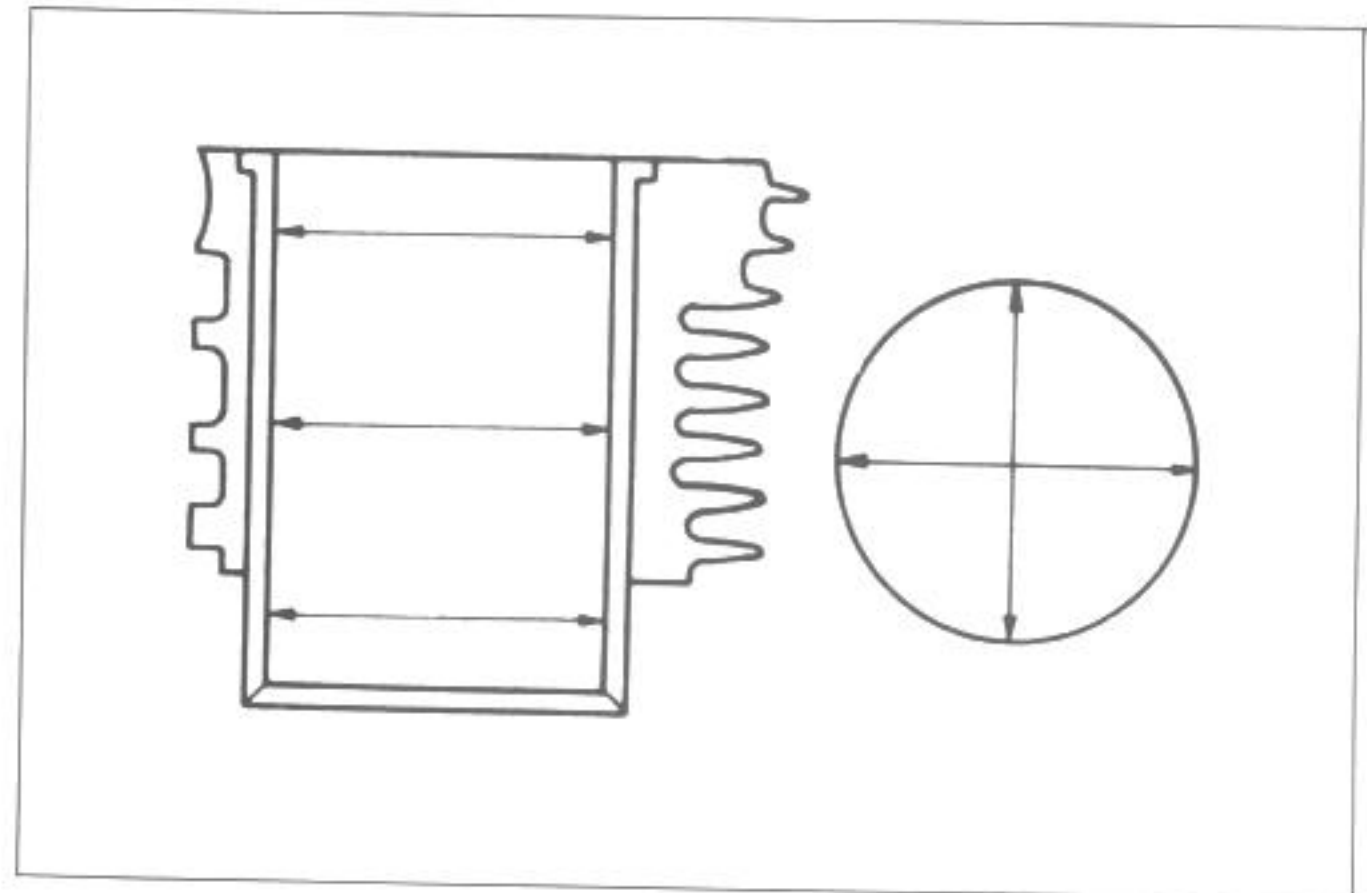
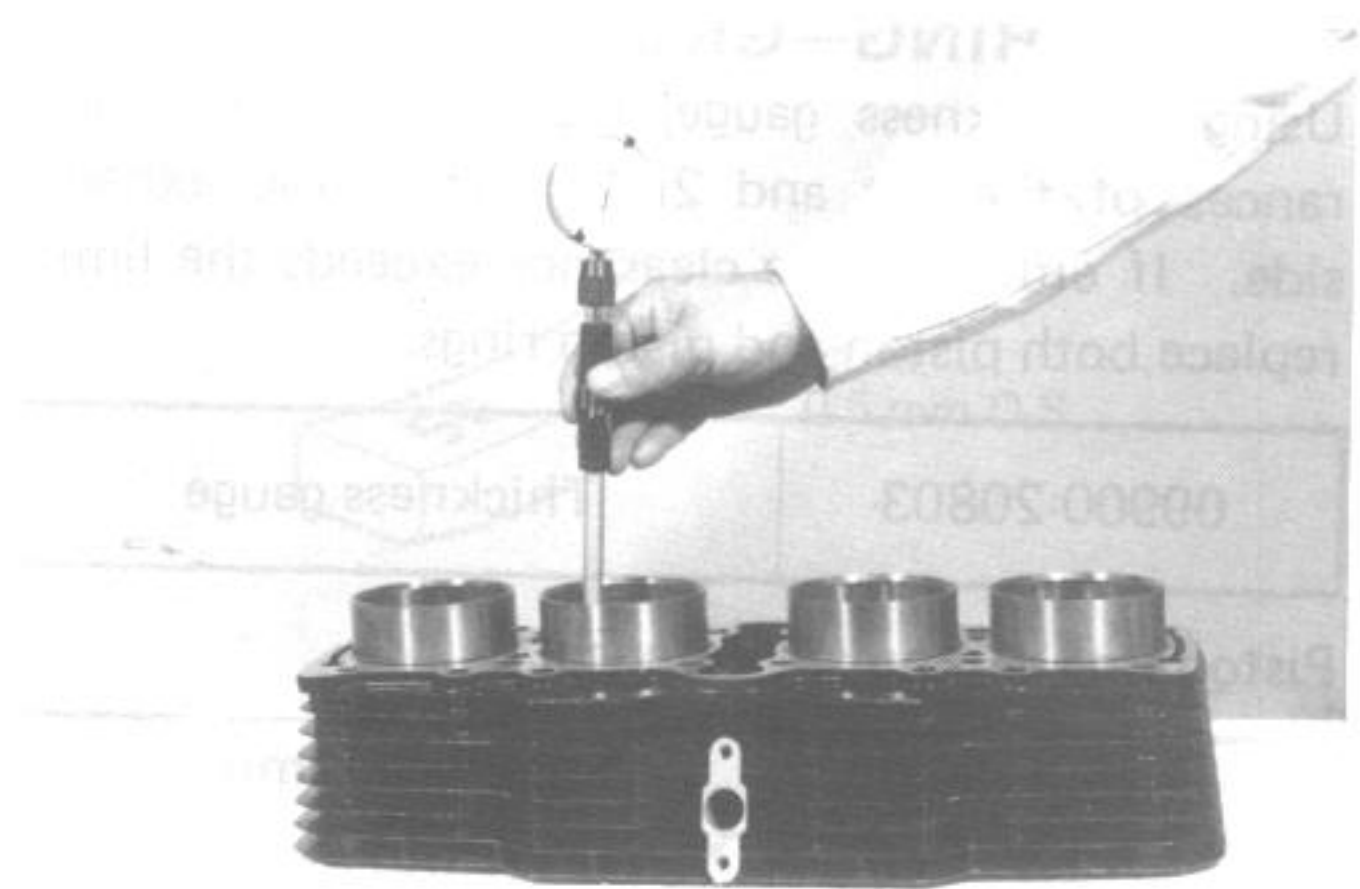

PISTON DIAMETER

Using a micrometer, measure the piston outside diameter at the place shown in Fig. If the measurement is less than the limit, replace the piston.

Piston oversize	0.5, 1.0 mm
Service Limit	73,880 mm
09900-20203	Micrometer (50–75 mm)

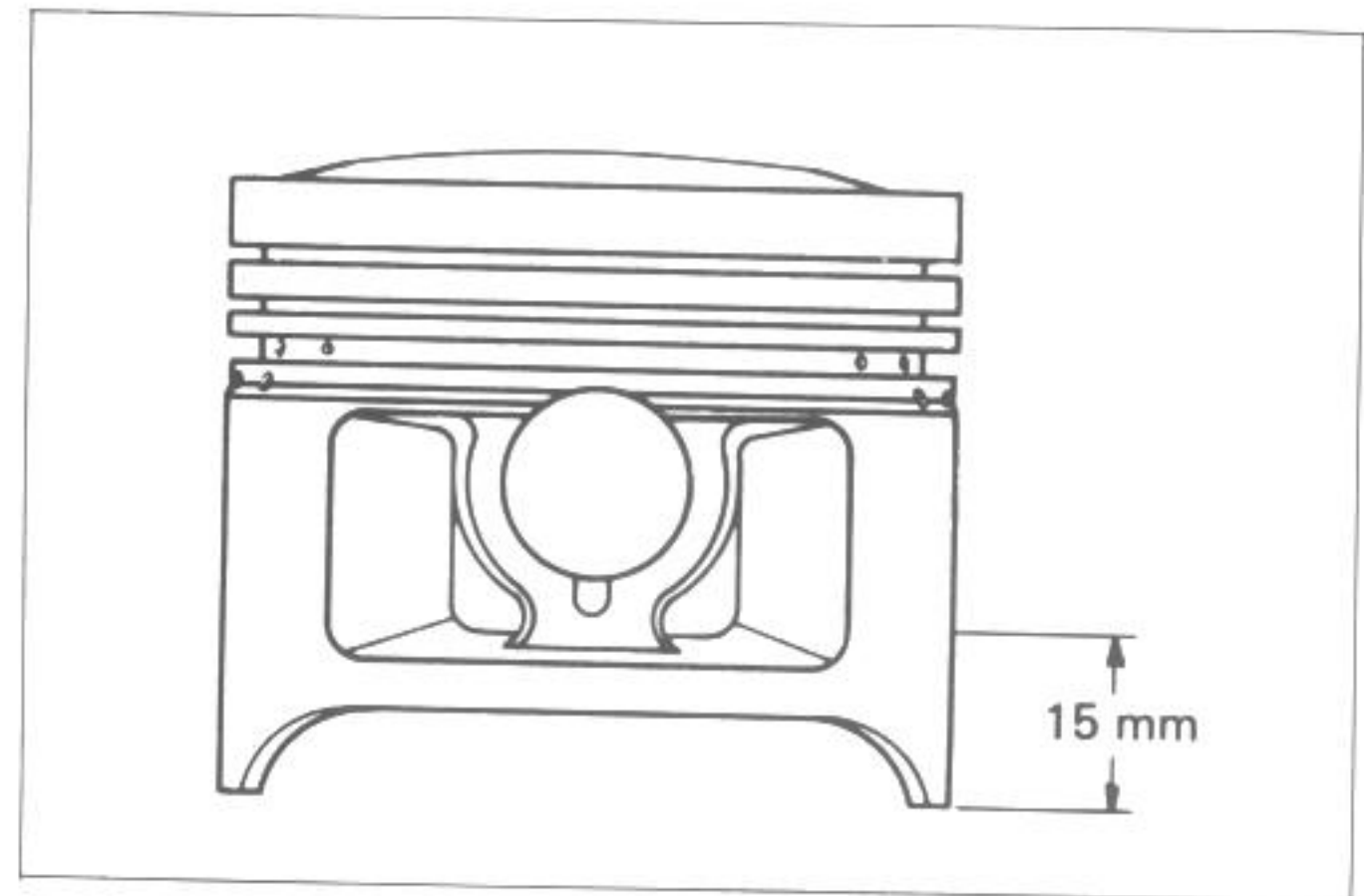

PISTON—CYLINDER CLEARANCE

As a result of the above measurement, if the piston clearance exceeds the following limit, overhaul the cylinder and use an oversize piston, or replace both cylinder and piston.

Service Limit	0.120 mm
---------------	----------

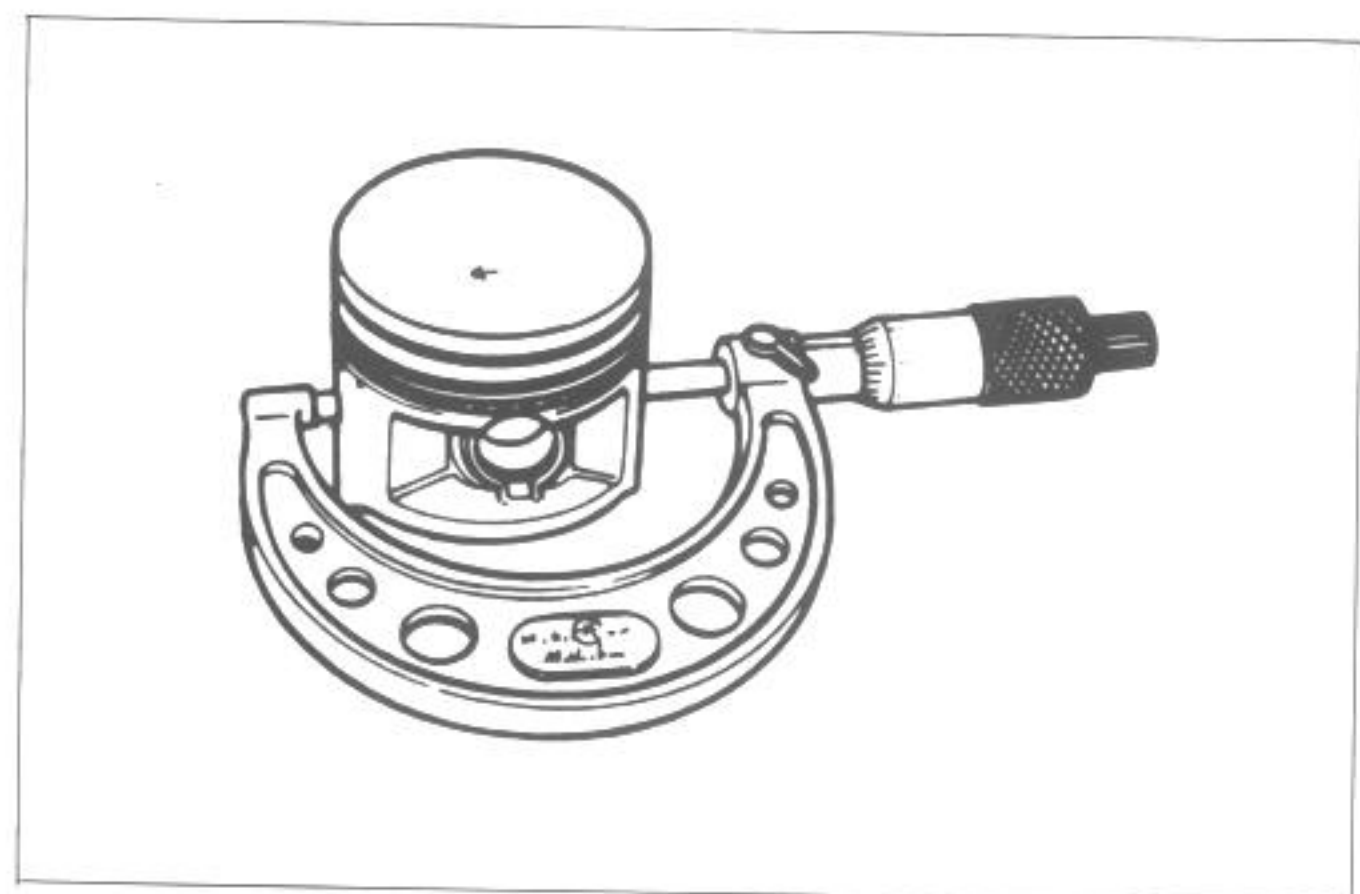

PISTON RING—GROOVE CLEARANCE

Using a thickness gauge, measure the side clearances of the 1st and 2nd rings at the exhaust side. If either of the clearance exceeds the limit, replace both piston and piston rings.

09900-20803	Thickness gauge
-------------	-----------------

Piston ring — groove clearance

Piston ring	Service Limit
1st	0.180 mm
2nd	0.150 mm

Piston ring groove width

Piston ring	Standard
1st	1.01 – 1.03 mm
2nd	1.21 – 1.23 mm
Oil	2.01 – 2.03 mm

Piston ring thickness

Piston ring	Standard
1st	0.975 – 0.990 mm
2nd	1.170 – 1.190 mm

PISTON RING FREE END GAP AND PISTON RING END GAP

Before installing piston rings, measure the free end gap of each ring using vernier calipers. Next, fit the ring in the cylinder, and measure each ring end gap using a thickness gauge.

If any ring has an excess end gap, replace the ring.

Piston ring free end gap

Piston ring	Service Limit
1st	8.0 mm
2nd	8.8 mm

Piston ring end gap

Piston ring	Service Limit
1st and 2nd	0.7 mm

09900-20803	Thickness gauge
-------------	-----------------

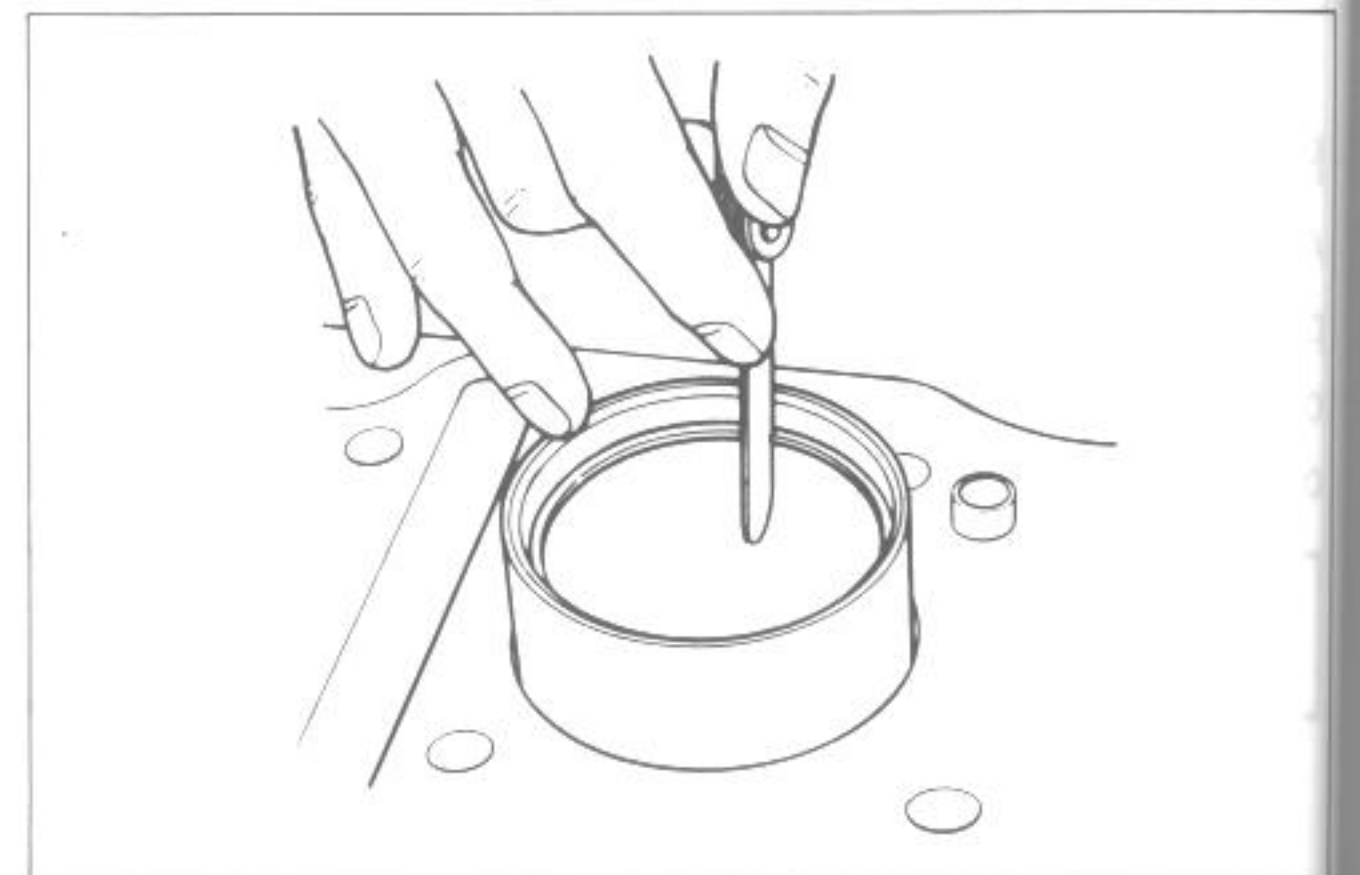
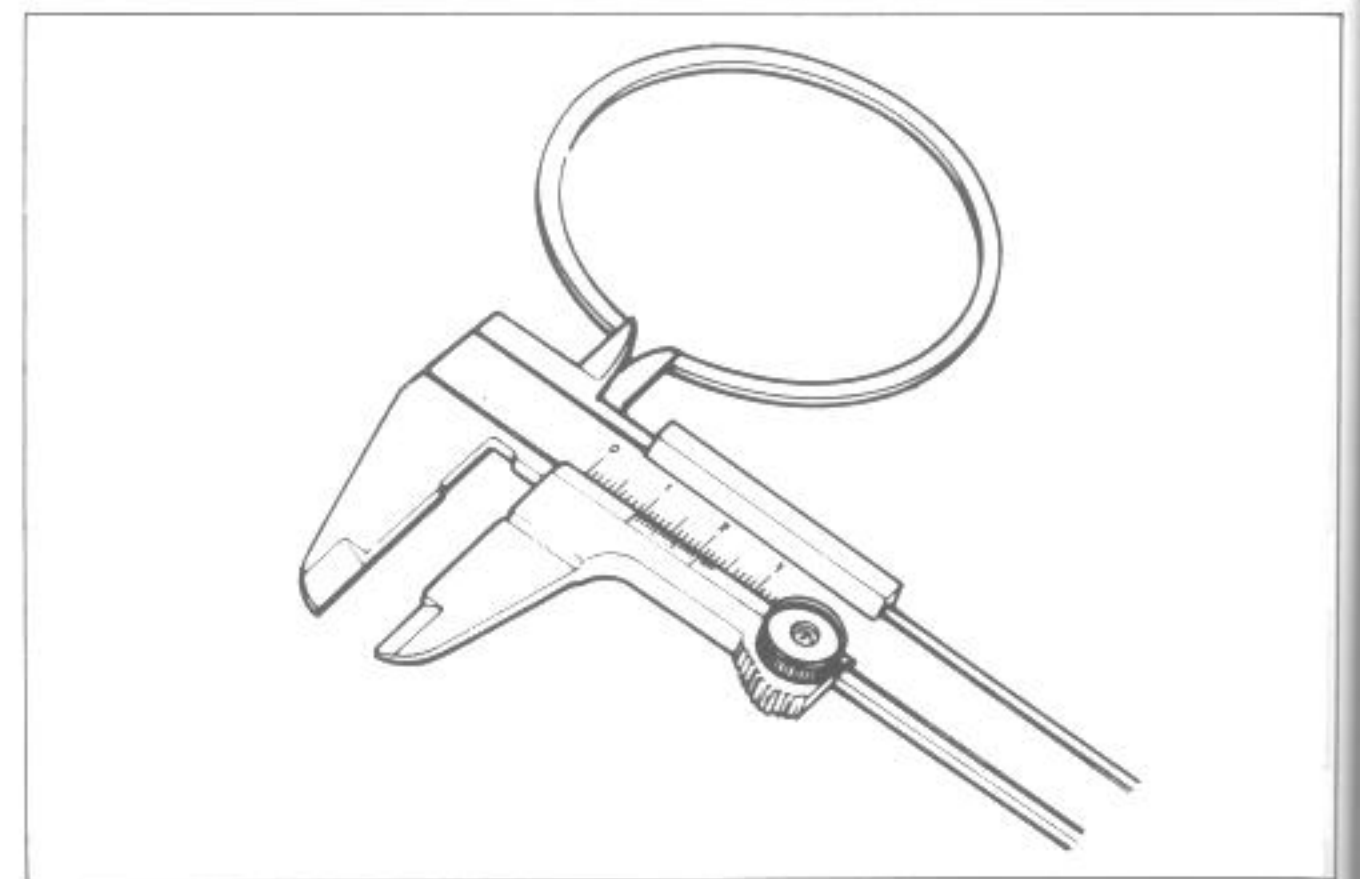
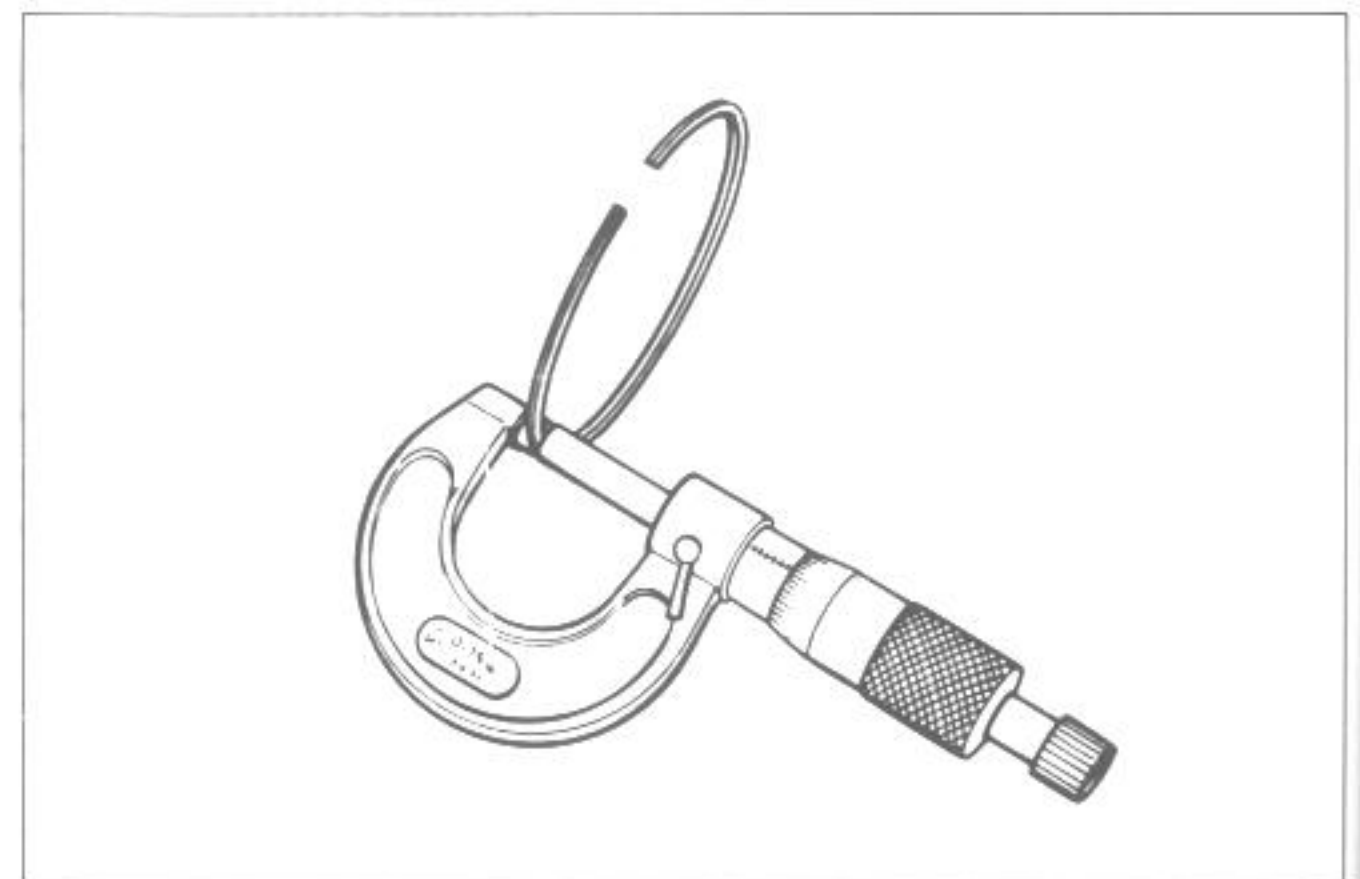
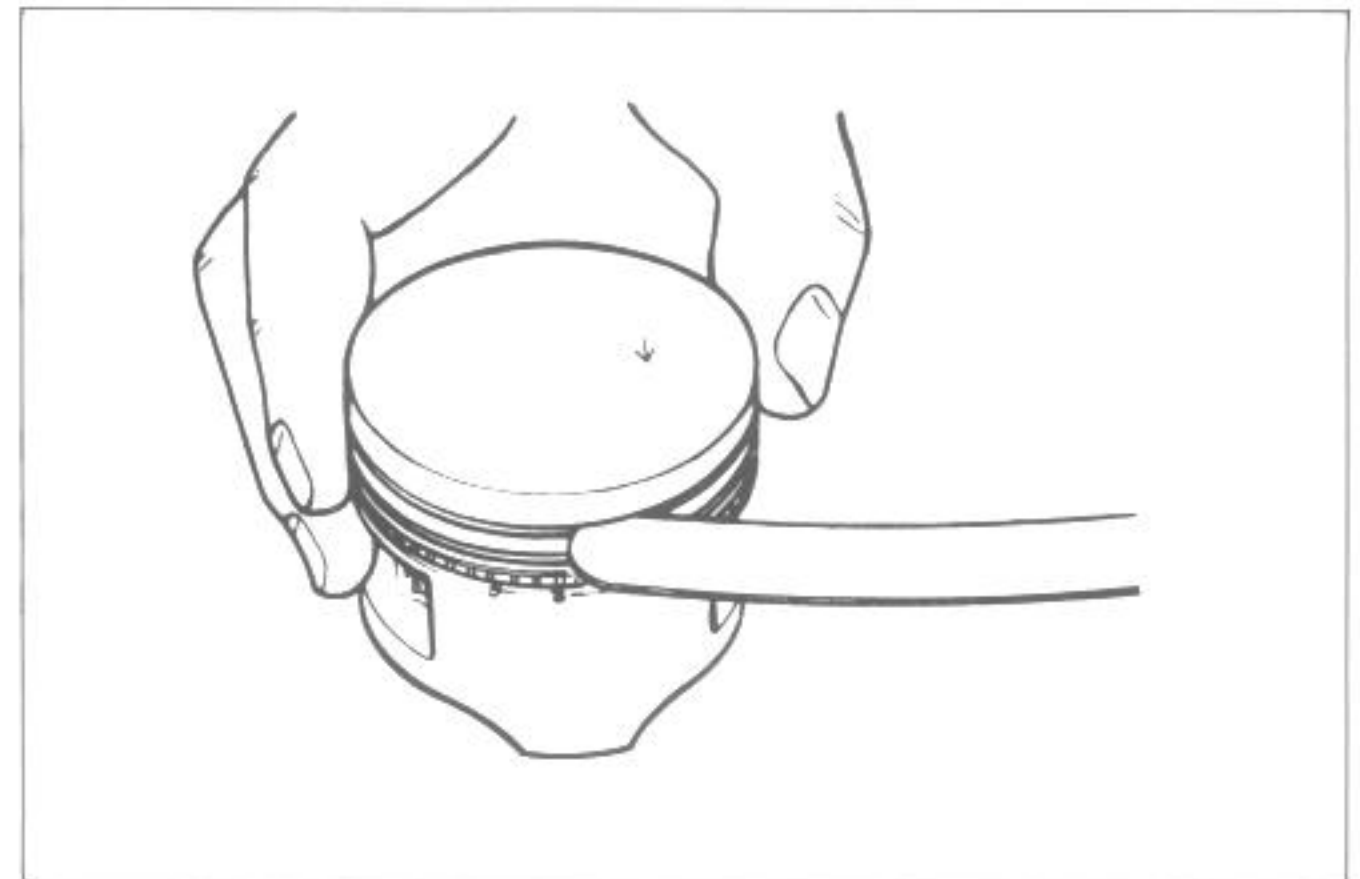

PIS
Using
bore
meas
meas
place

Piston

S

Using
side d

Piston

S

09

09

C

• **Oversize piston rings**

The following two types of oversize piston rings are used. They bear the following identification numbers.

	1st	2nd
0.5 mm O.S.	50	50
1.0 mm O.S.	100	100

• **Oversize oil rings**

The following standard type and two types of oversize oil rings are used. They bear the following identification marks.

STD	Painted red
0.5 mm O.S.	Painted blue
1.0 mm O.S.	Painted yellow

• **Oversize side rail**

Just measure outside diameter to identify the size.

PISTON PIN AND PIN BORE

Using a small bore gauge, measure the piston pin bore inside diameter, and using a micrometer, measure the piston pin outside diameter. If the measurement readings are more than limit, replace piston, piston pin or both.

Piston pin bore I.D.

Service Limit	20,030 mm
---------------	-----------

Using a micrometer, measure the piston pin outside diameter at three positions.

Piston pin O.D.

Service Limit	19.980 mm
---------------	-----------

09900-22403	Small bore gauge (18 – 35 mm)
09900-20205	Micrometer (0 – 25 mm)

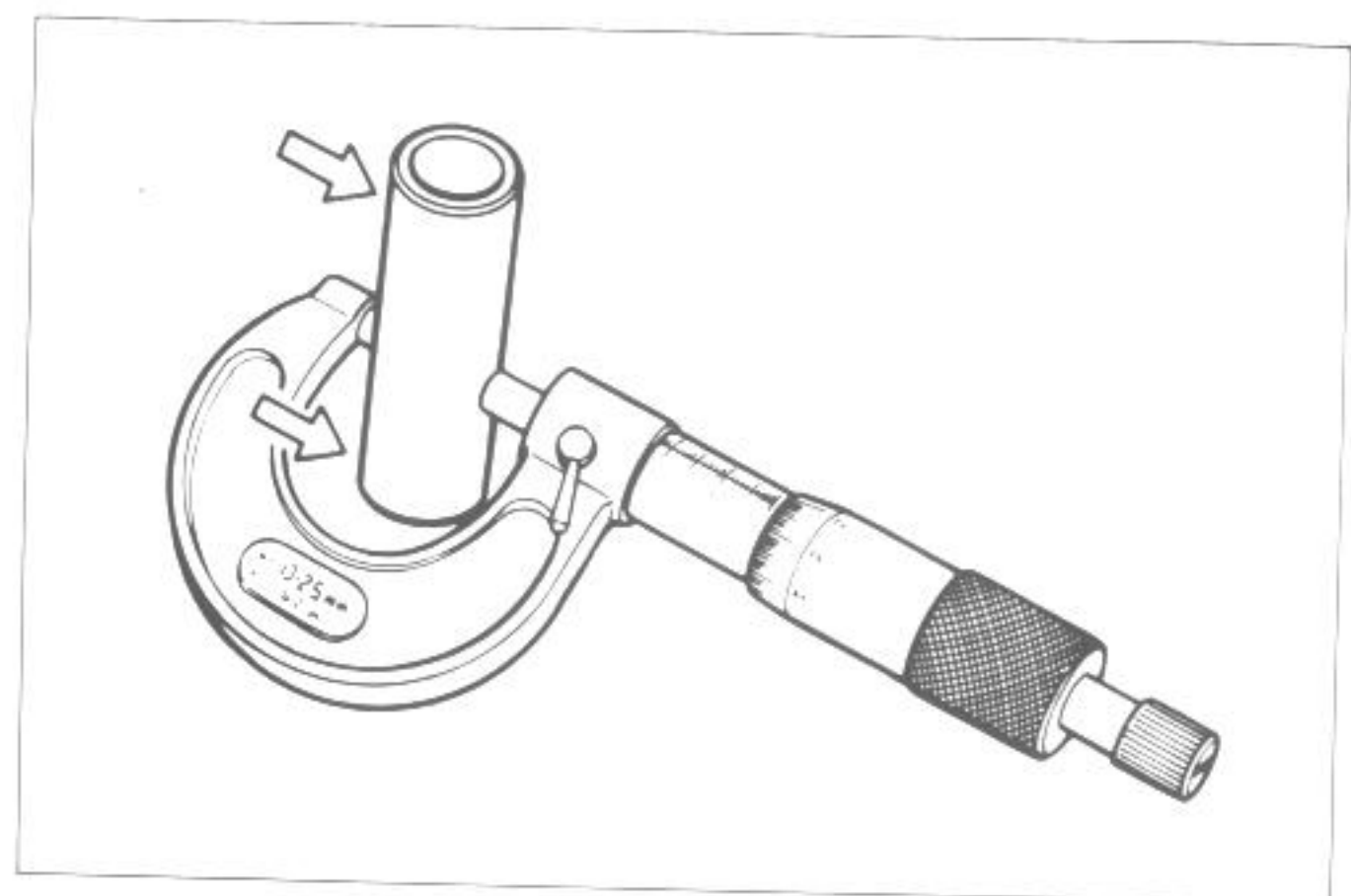
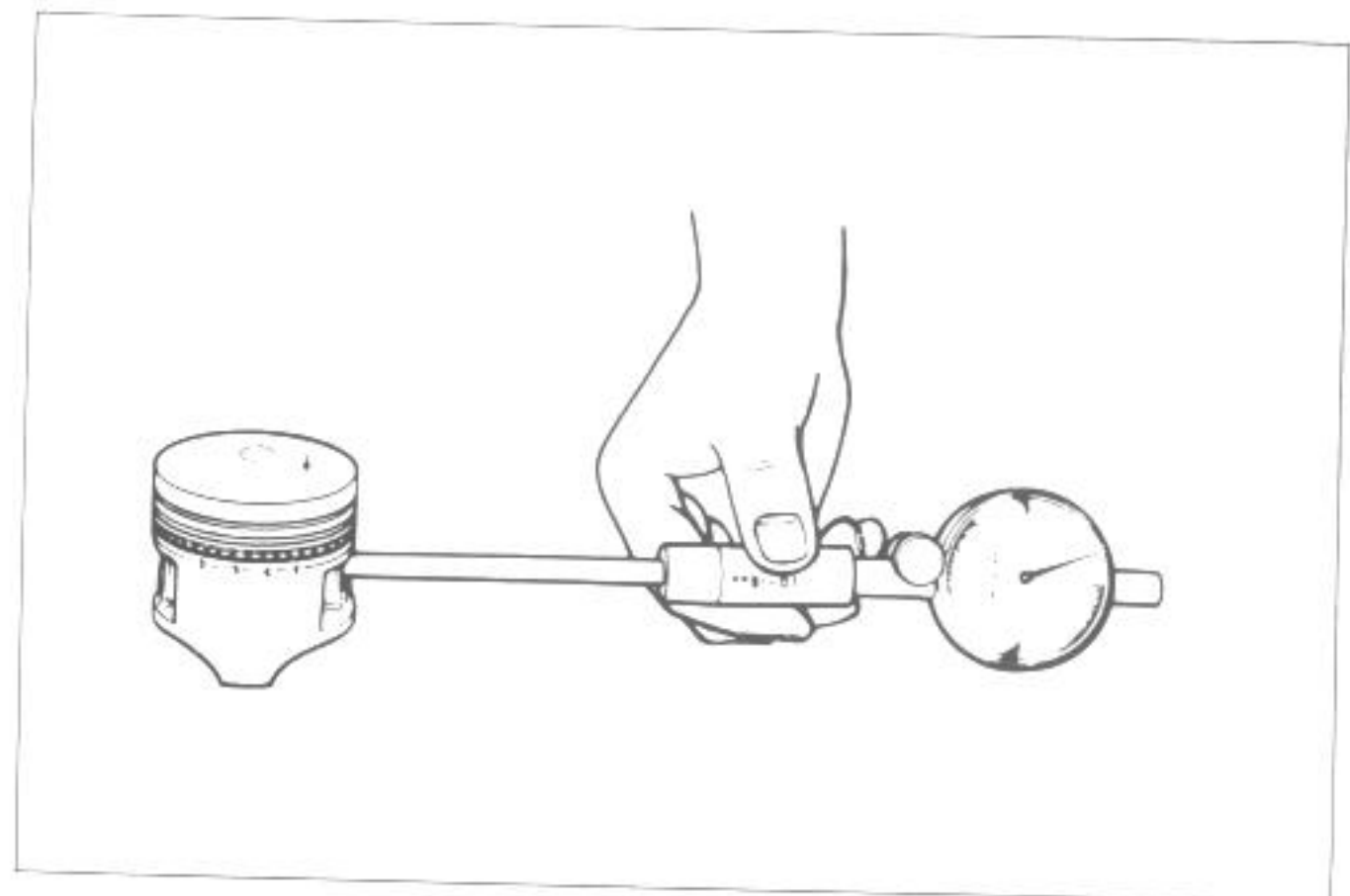
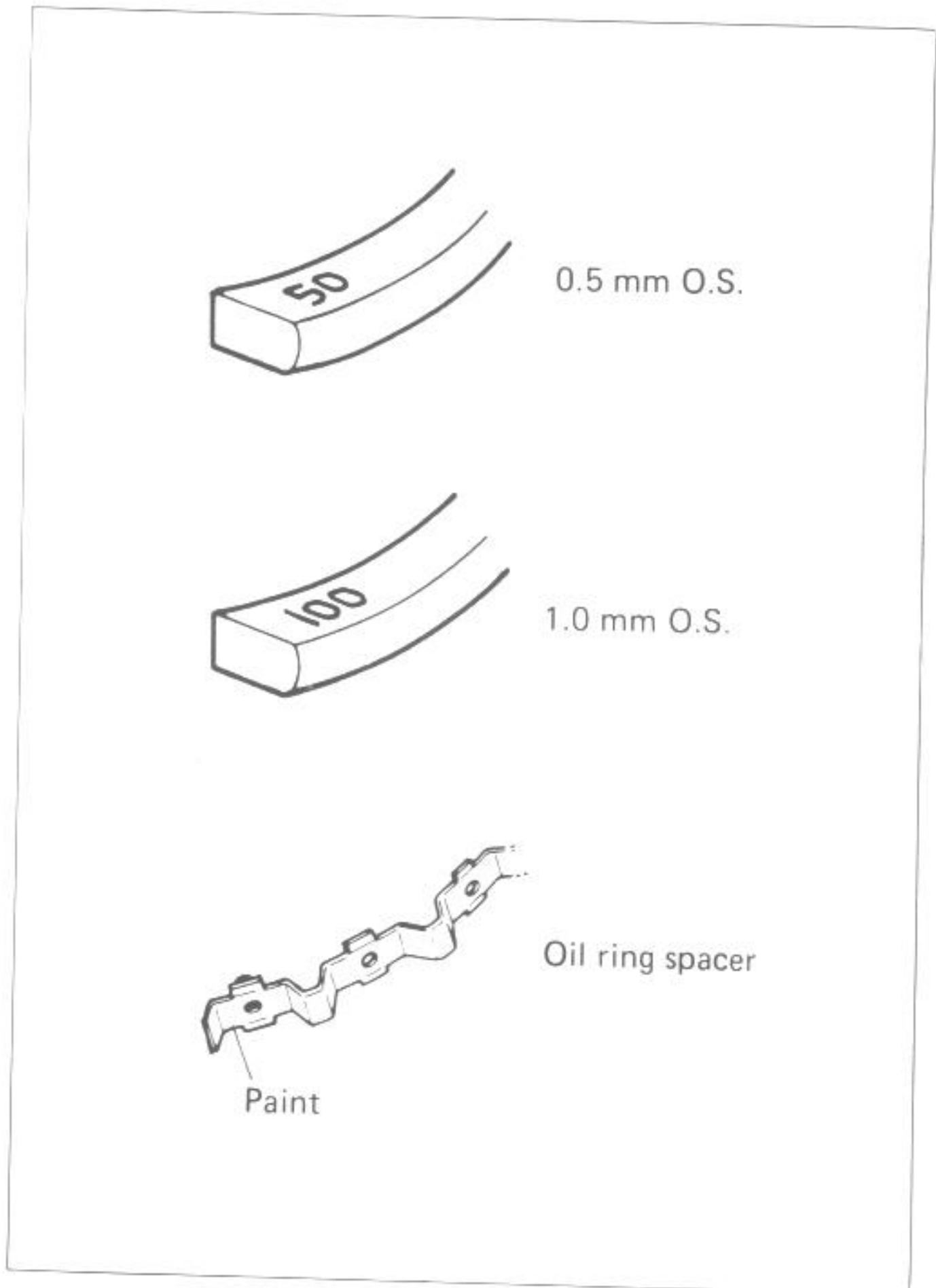

CONNECTING ROD SMALL END BORE I.D.

Using a small bore gauge, measure the connecting rod small end inside diameter.

Connecting rod small end bore I.D.

Service Limit	20.040 mm
---------------	-----------

09900-22403	Small bore gauge (18 – 35 mm)
-------------	----------------------------------

- If the connecting rod small end bore inside diameter exceeds the abovementioned limit, replace connecting rod or crankshaft assembly.

CONNECTING ROD BIG END THRUST CLEARANCE

Check the connecting rod side clearance by using thickness gauge. If the clearance exceeds the limit, replace connecting rod or crankshaft.

Service Limit	1.0 mm
---------------	--------

09900-20803	Thickness gauge
-------------	-----------------

CRANK PIN WEAR AND BIG END BEARING WEAR

Check the wear of each crankpin in terms of connecting rod movement using a dial gauge as shown.

Service Limit	3.0 mm
---------------	--------

Where the limit is exceeded, replace crankshaft assembly or reduce the deflection and the side clearance within the limit by replacing the worn parts – connecting rod, big end bearing, crankpin and thrust washer, etc.

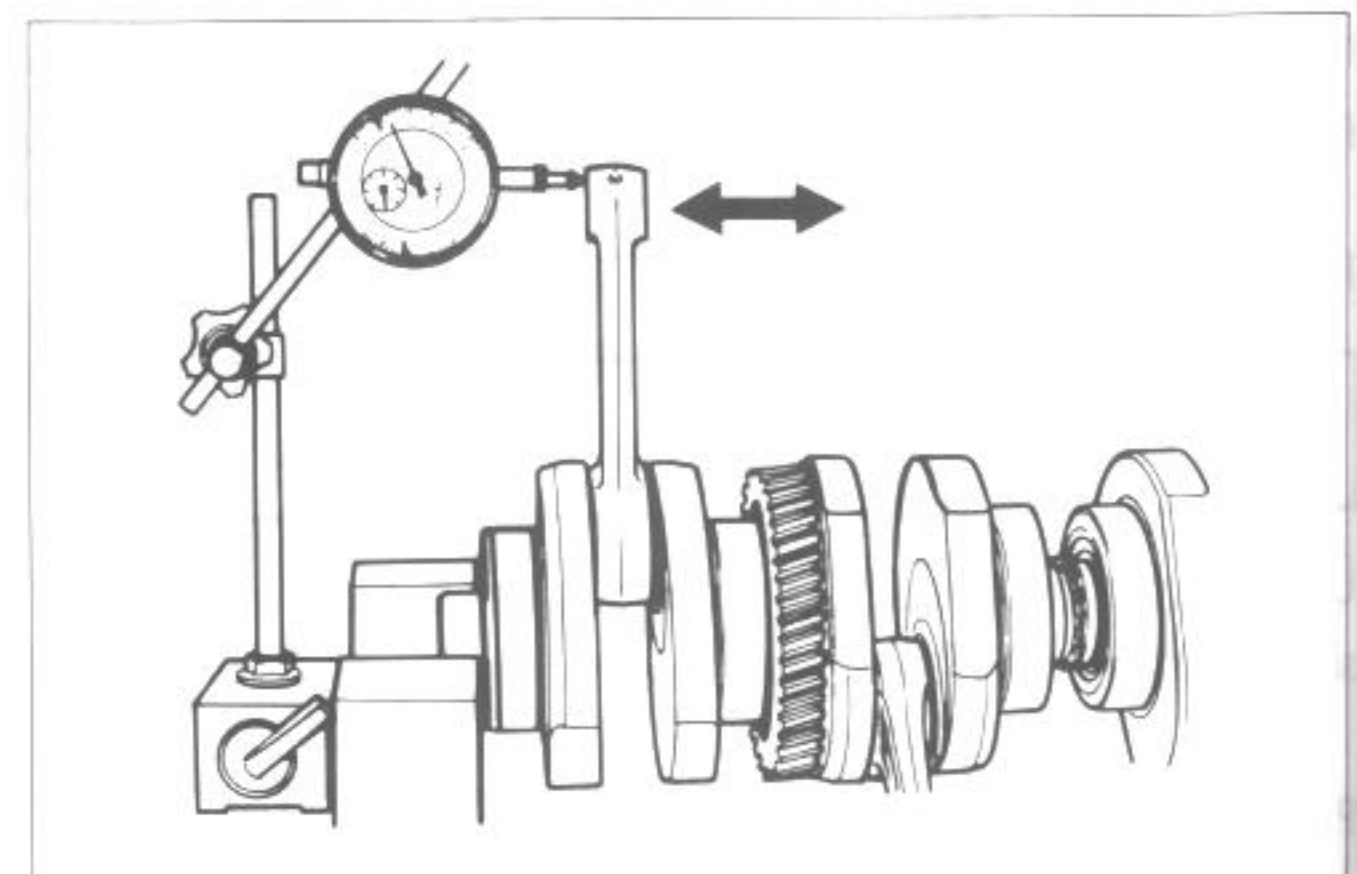
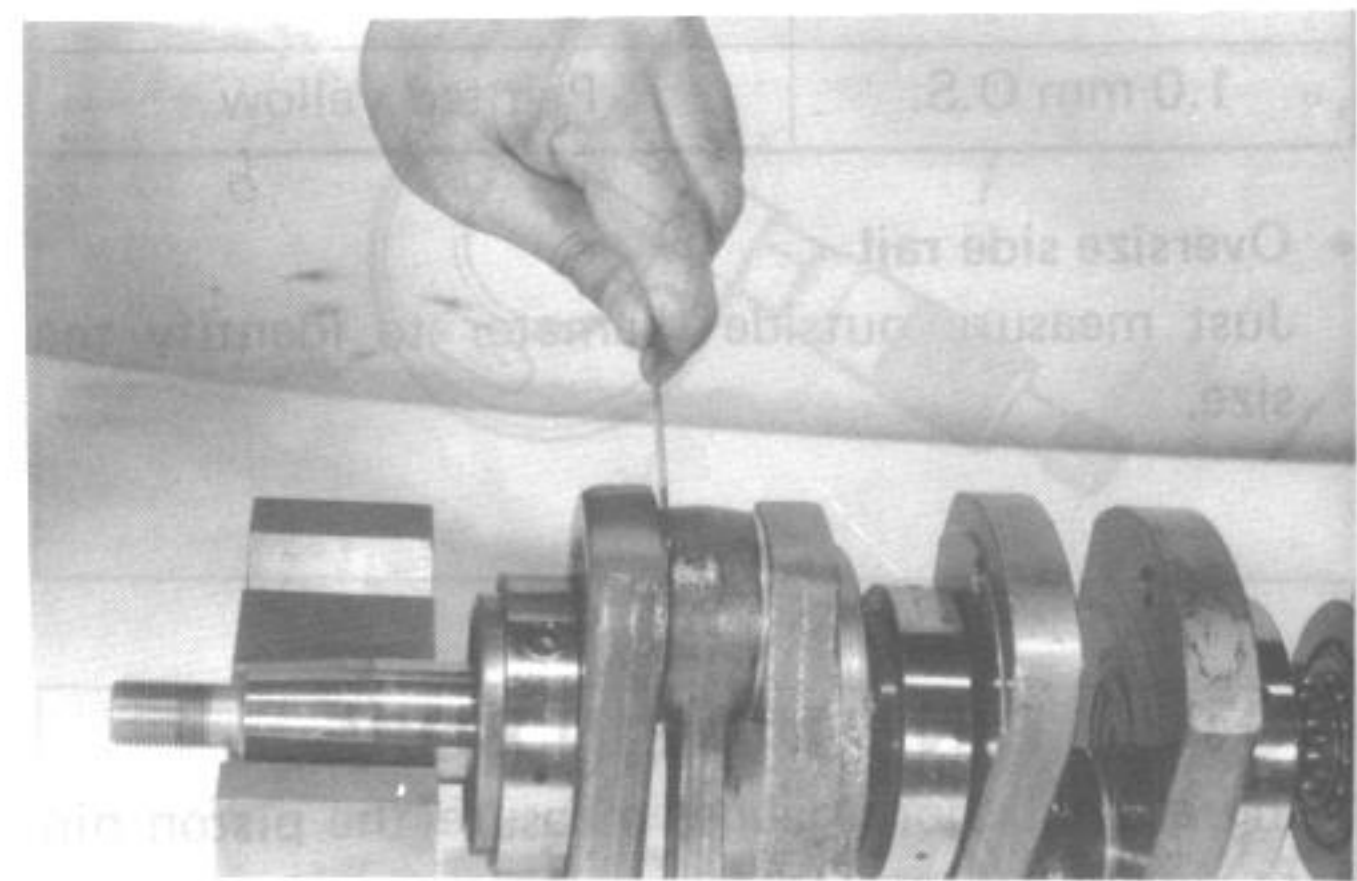
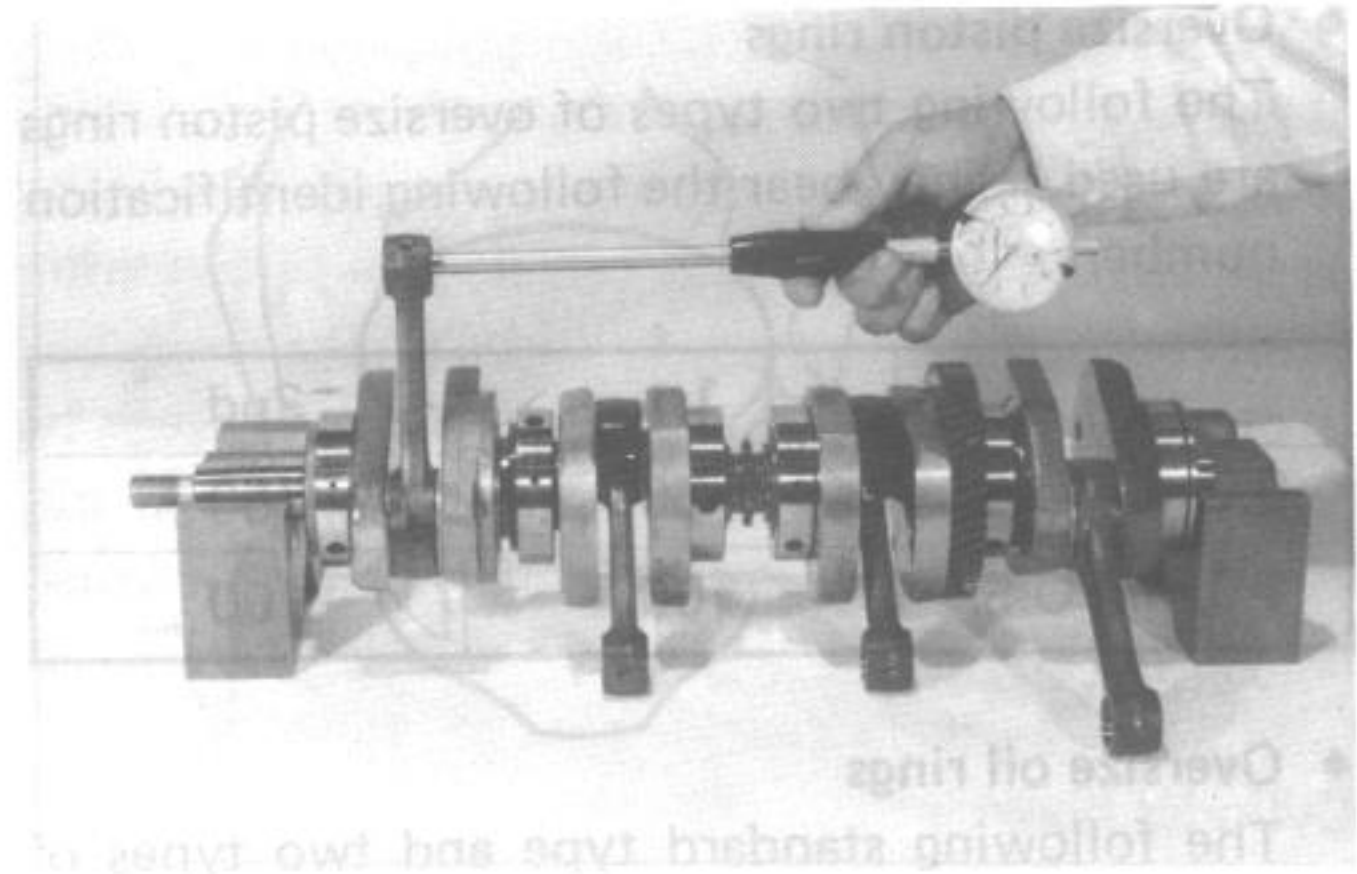

CRA

Supp
with

Set u

crank

Repla

than

0

0

Crank

S

Check

AS

**CLUT
DRIV**

Clutch

Be caus

plates a

largely

also on

These p

replac

the res

check

plate to

099

099

Servic

Thic

Dist

Claw

CRANKSHAFT RUNOUT

Support the crankshaft with "V" blocks as shown, with the two end journals resting on the blocks. Set up the dial gauge, as shown, and rotate the crankshaft slowly to read the runout.

Replace the crankshaft if the runout is greater than the limit.

09900-20606	Dial gauge (1/100 mm)
09900-20701	Magnetic stand

Crankshaft runout

Service Limit	0.10 mm
---------------	---------

Check the connecting rod for smooth turning.

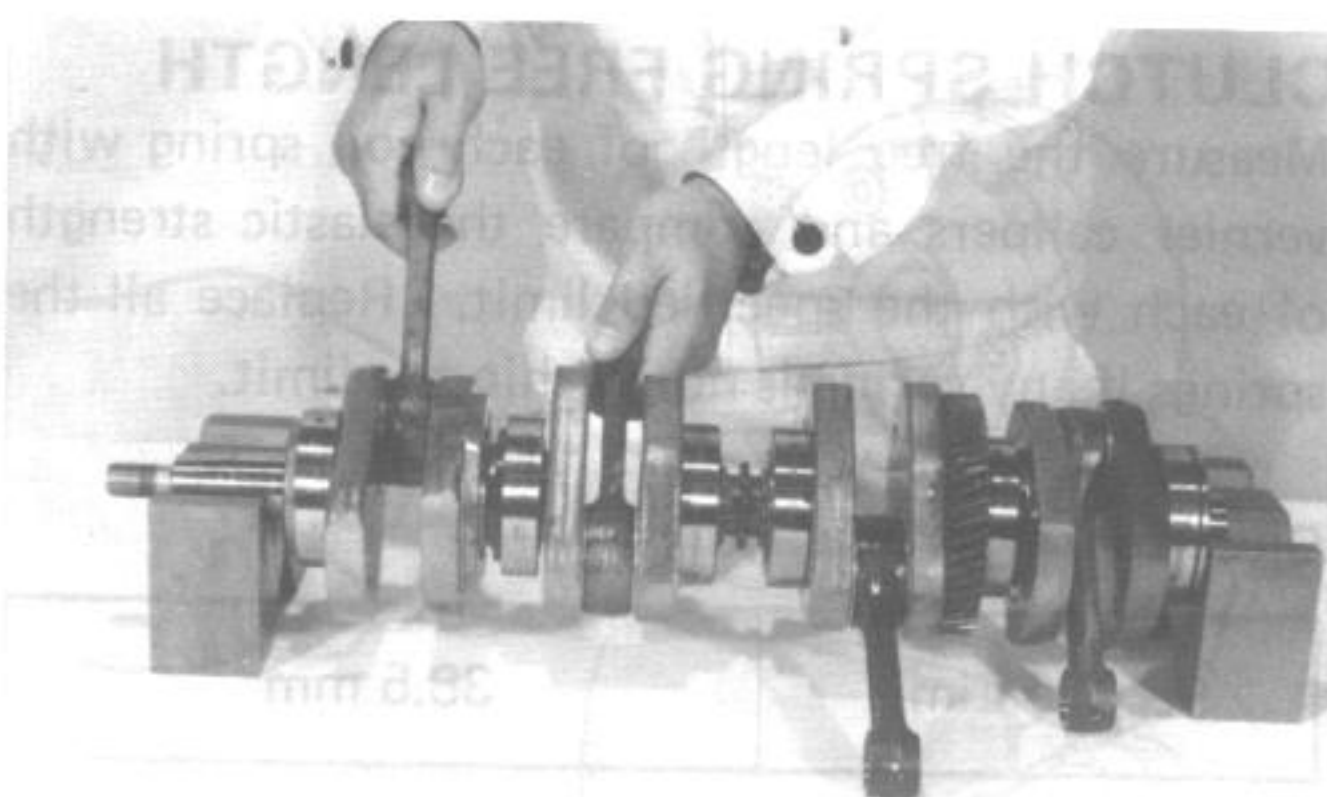
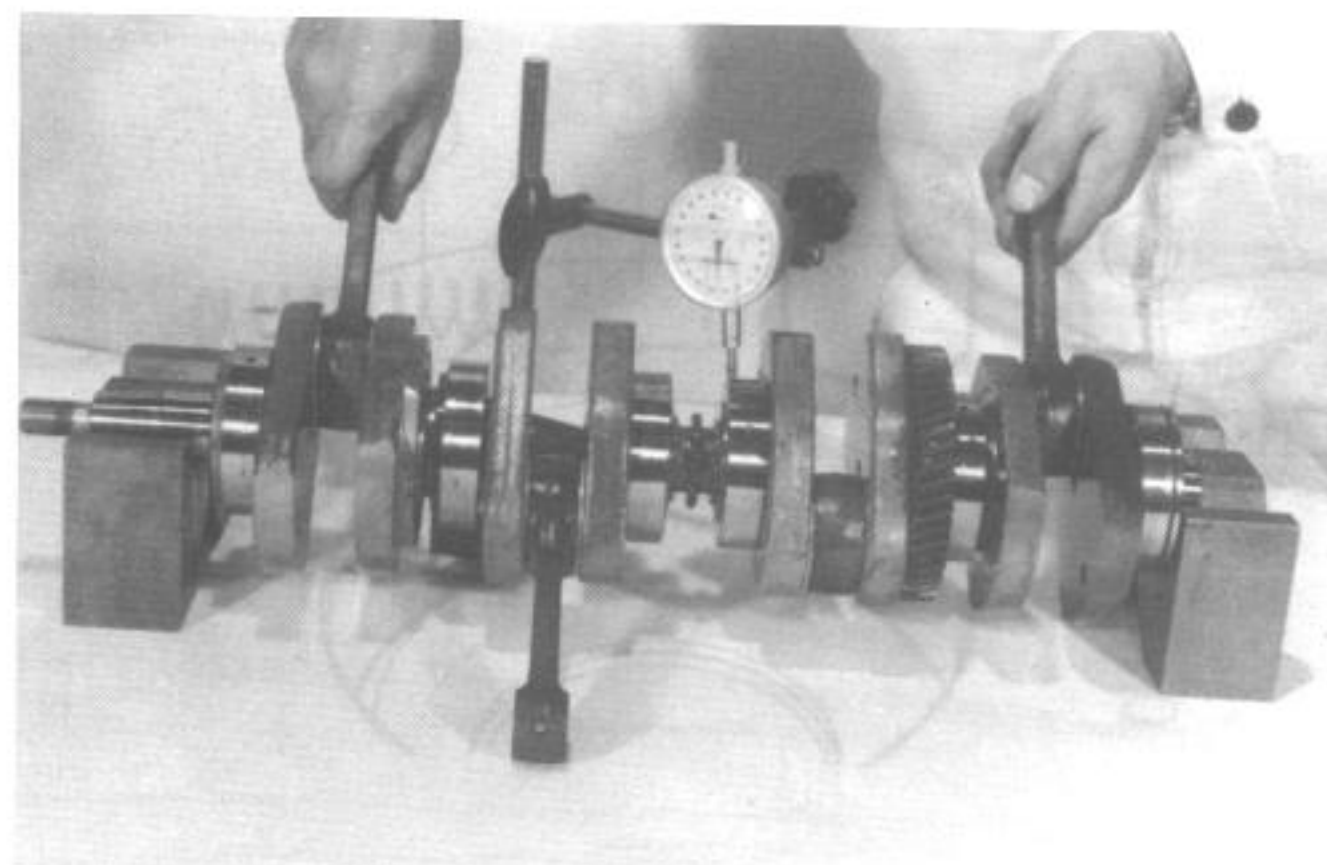

CLUTCH DRIVE PLATES AND DRIVEN PLATES

Clutch plates in service are lubricated with oil. Because of this condition, both drive and driven plates are subject to little wear. Their life depends largely on the quality of oil used in the engine and also on the way the clutch is operated.

These plates are expendable: they are meant to be replaced when found worn down or distorted to the respective limit. Use a vernier calipers to check thickness and a thickness gauge and surface plate to check distortion.

09900-20102	Vernier calipers
09900-20803	Thickness gauge

Unit: mm

Service Limit	Drive plate	Driven plate
Thickness	2.6	—
Distortion	—	0.10
Claw width	14.8	—

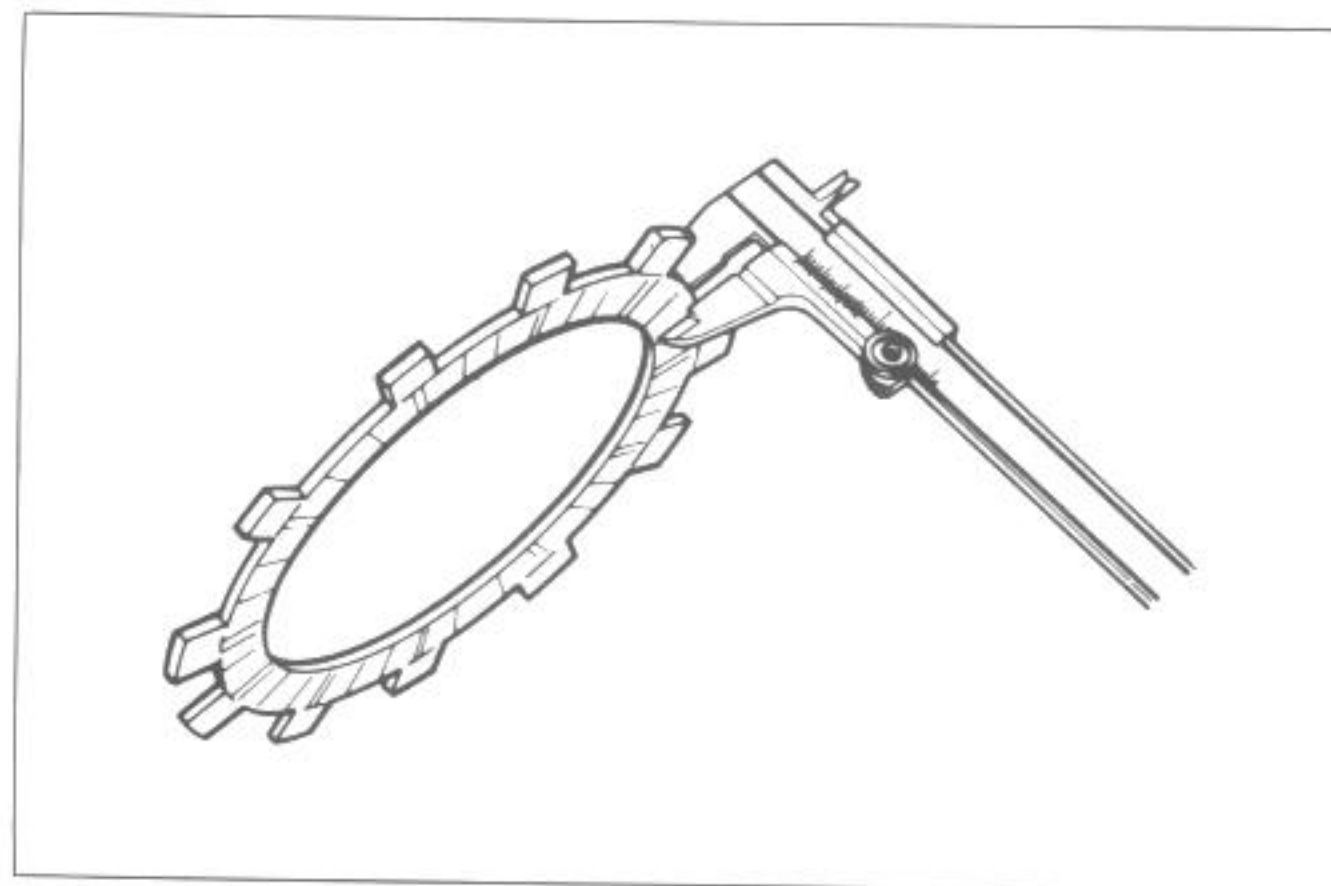

Checking thickness

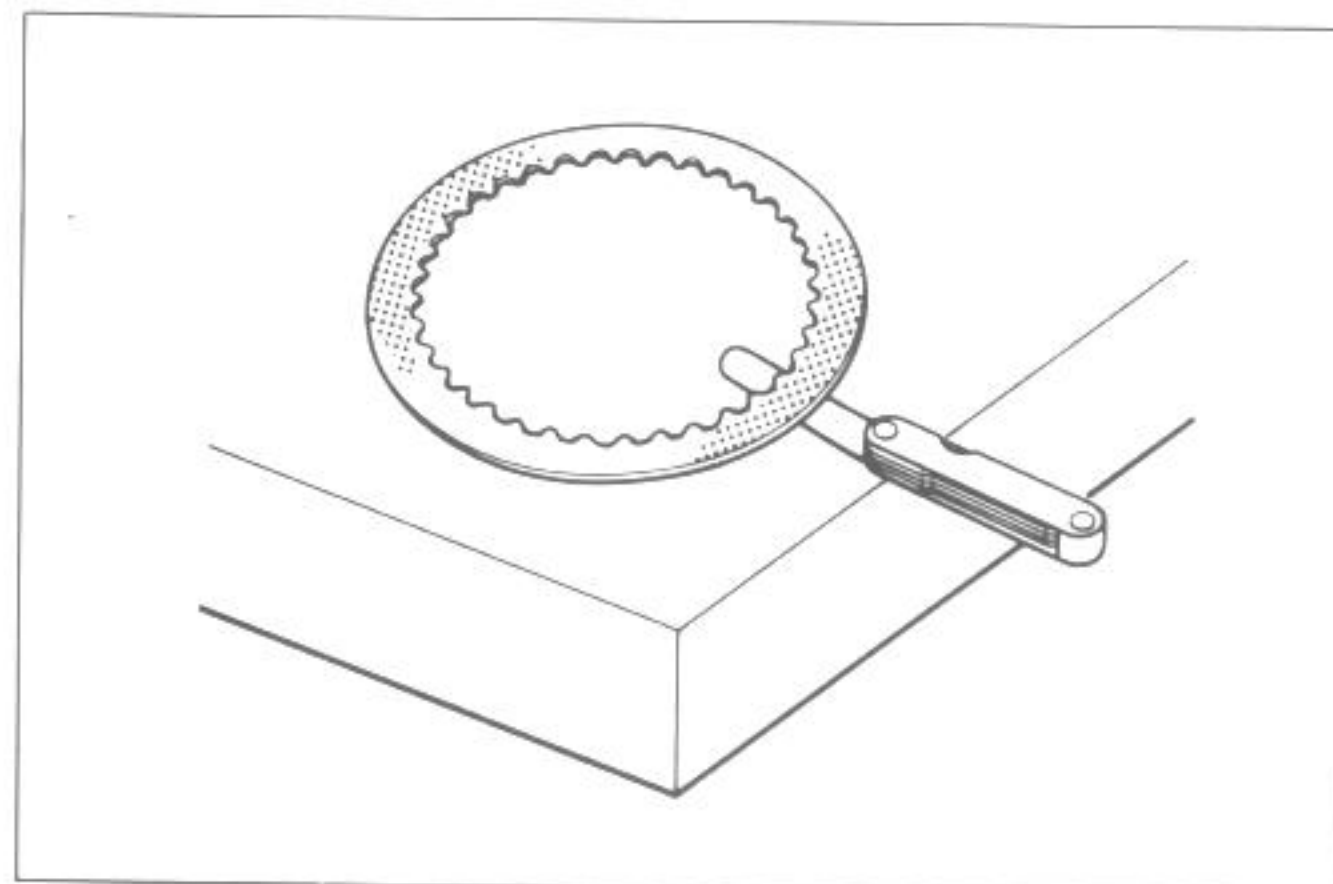

Checking distortion

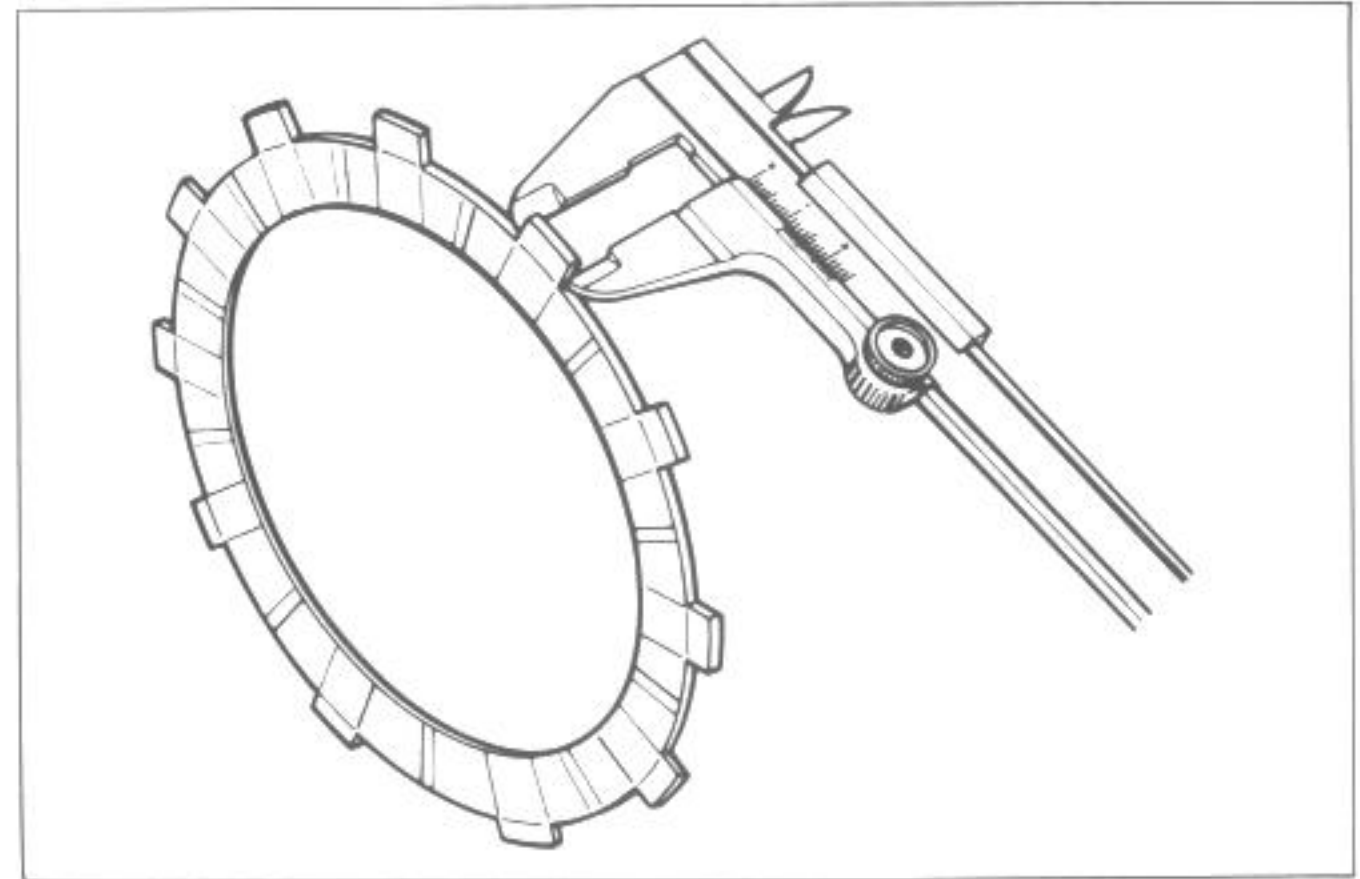

Checking claw width

CLUTCH SPRING FREE LENGTH

Measure the free length of each coil spring with vernier calipers and compare the elastic strength of each with the specified limit. Replace all the springs if any spring is not within the limit.

Clutch spring free length

Service Limit	38.5 mm
---------------	---------

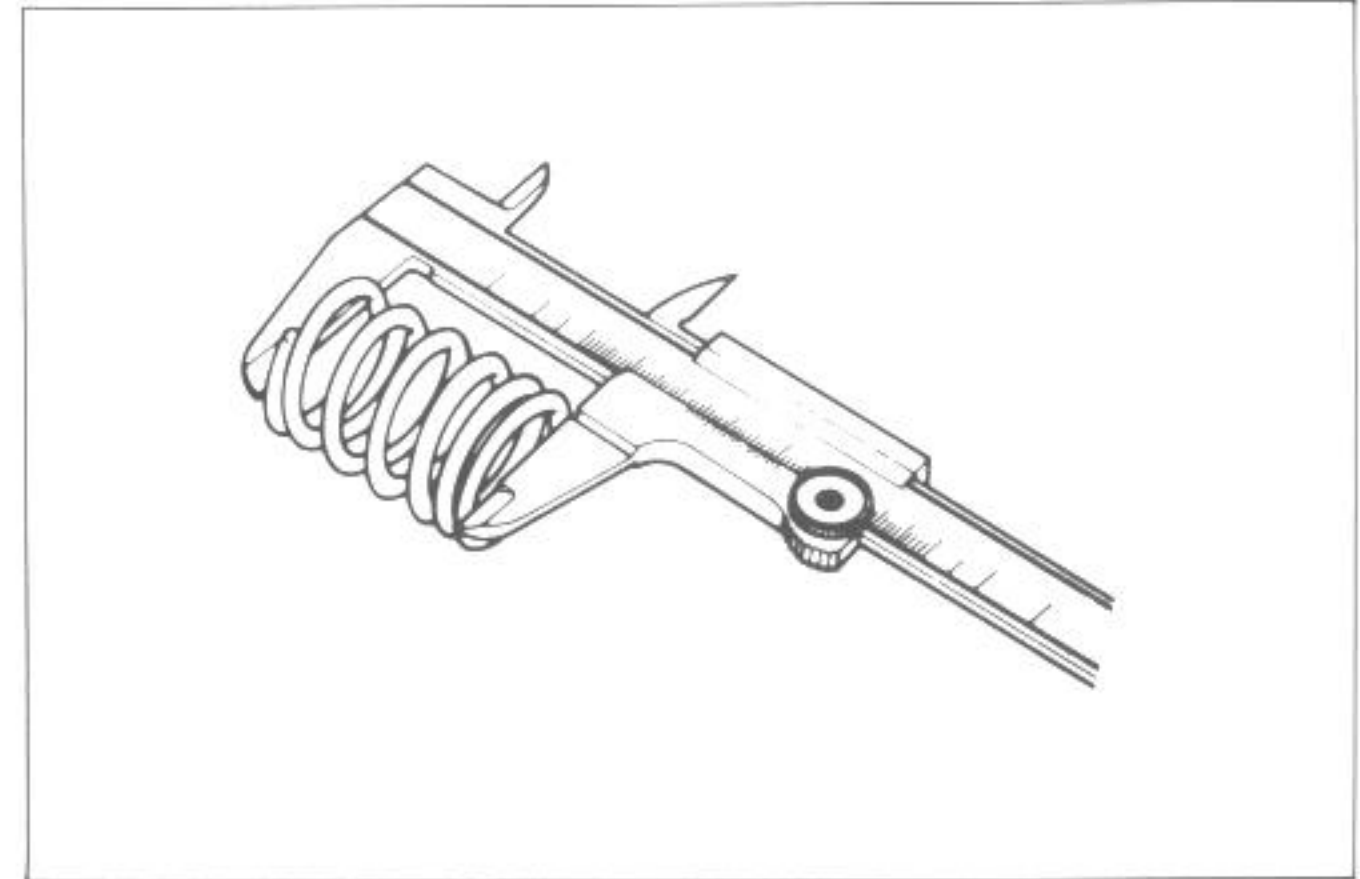

CLUTCH BEARINGS

Inspect clutch release and rack bearings for any abnormality, particularly cracks or wear, upon removal from the clutch, to decide whether it can be reused or should be replaced.

Smooth engagement and disengagement of the clutch depends much on the condition of these bearings.



SLEEVE HUB WAVE WASHER

- Install the spring seat, spring and driven plate in the clutch sleeve hub. Check that these three parts are positioned correctly as illustrated. While holding the driven plate with pliers, install the piano wire clip.

NOTE:
Always use a new piano wire clip.

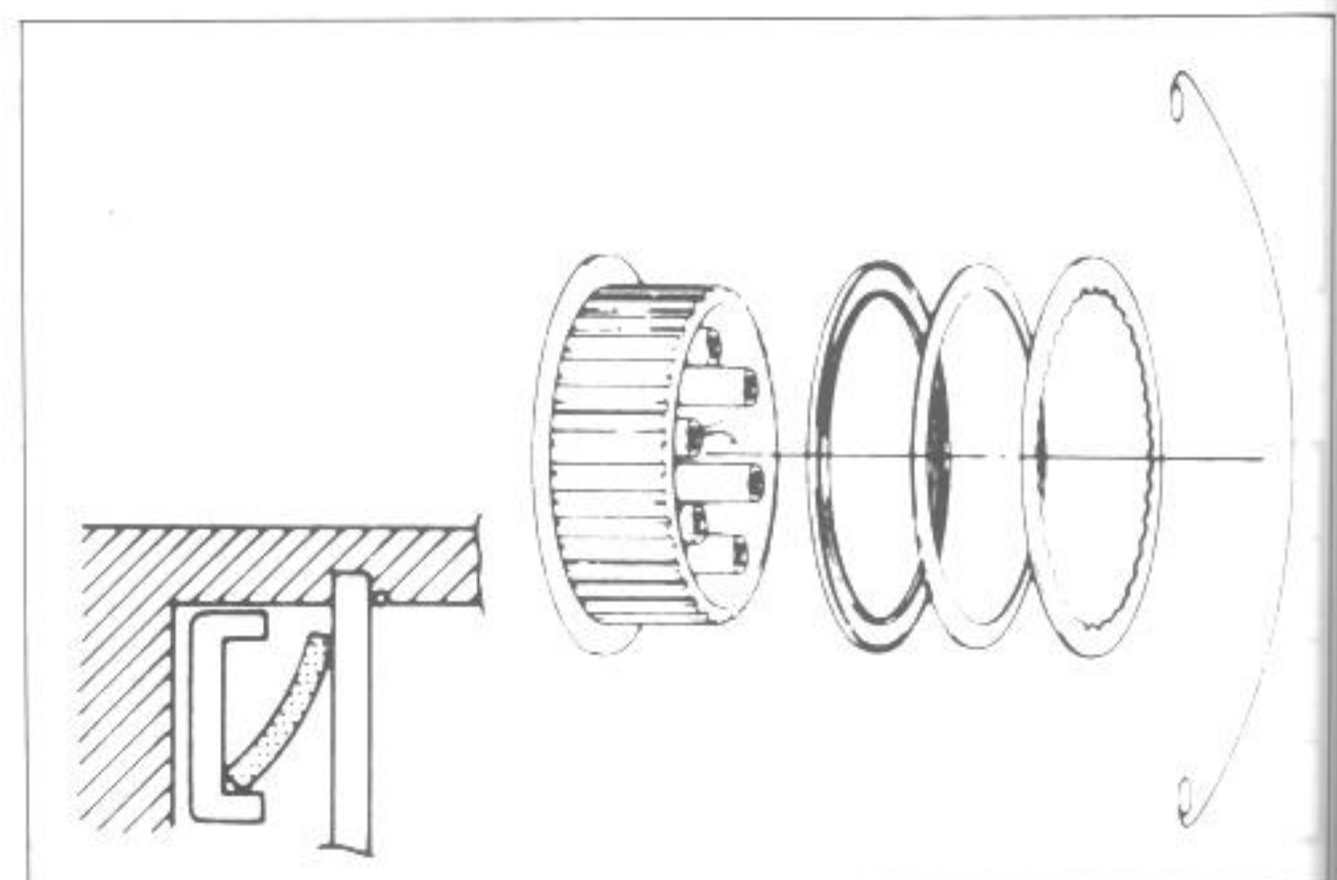

STARTER CLUTCH REMOVAL

- Remove the roller ①, spring ② and push piece ③ from the starter clutch.

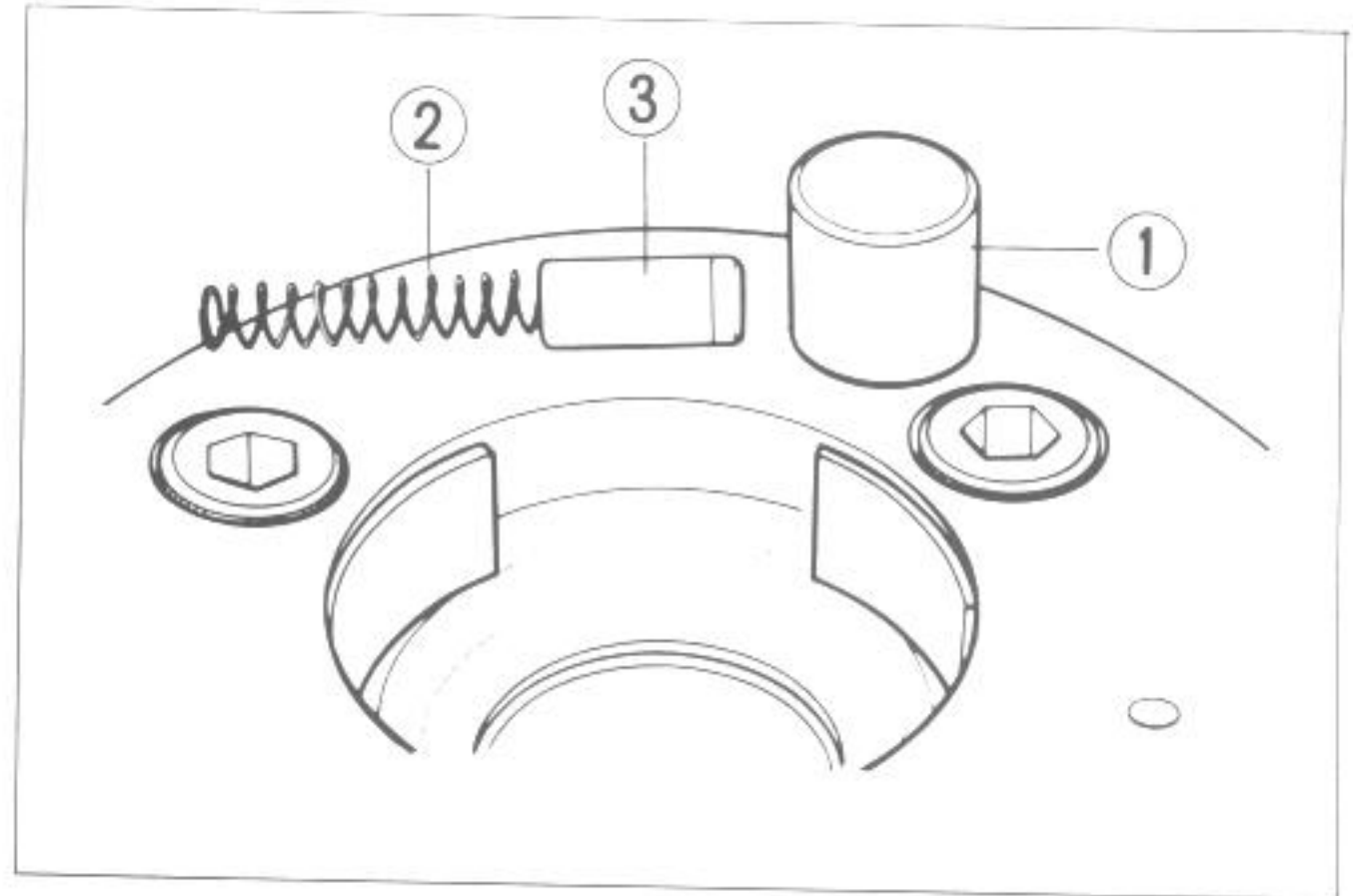

- Clamp the rotor with the special tool and a vice taking care not to damage it and remove the three hexagon bolts using the 6 mm "T" type hexagon wrench.

09914-25811	"T" type hexagon wrench (6 mm)
09930-44911	Rotor holder

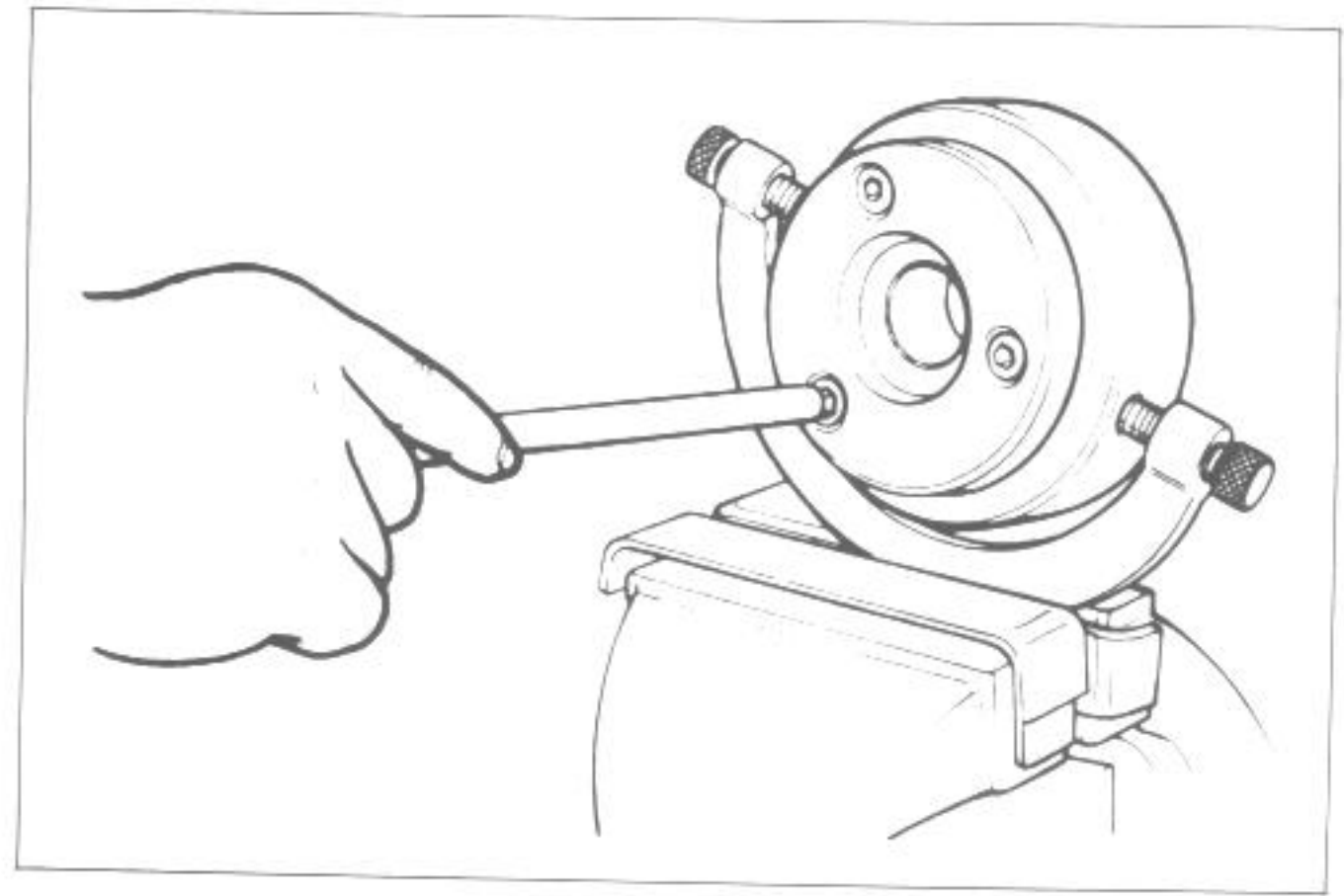

ASSEMBLY

- Apply THREAD LOCK "1342" to the stator set screws and its lead wire guide screws.

99000-32050	Thread lock "1342"
-------------	--------------------

NOTE:

Wipe off oil and grease on screw completely and then apply the screw lock.

- Mount the lead wire clamp as shown in the photo.

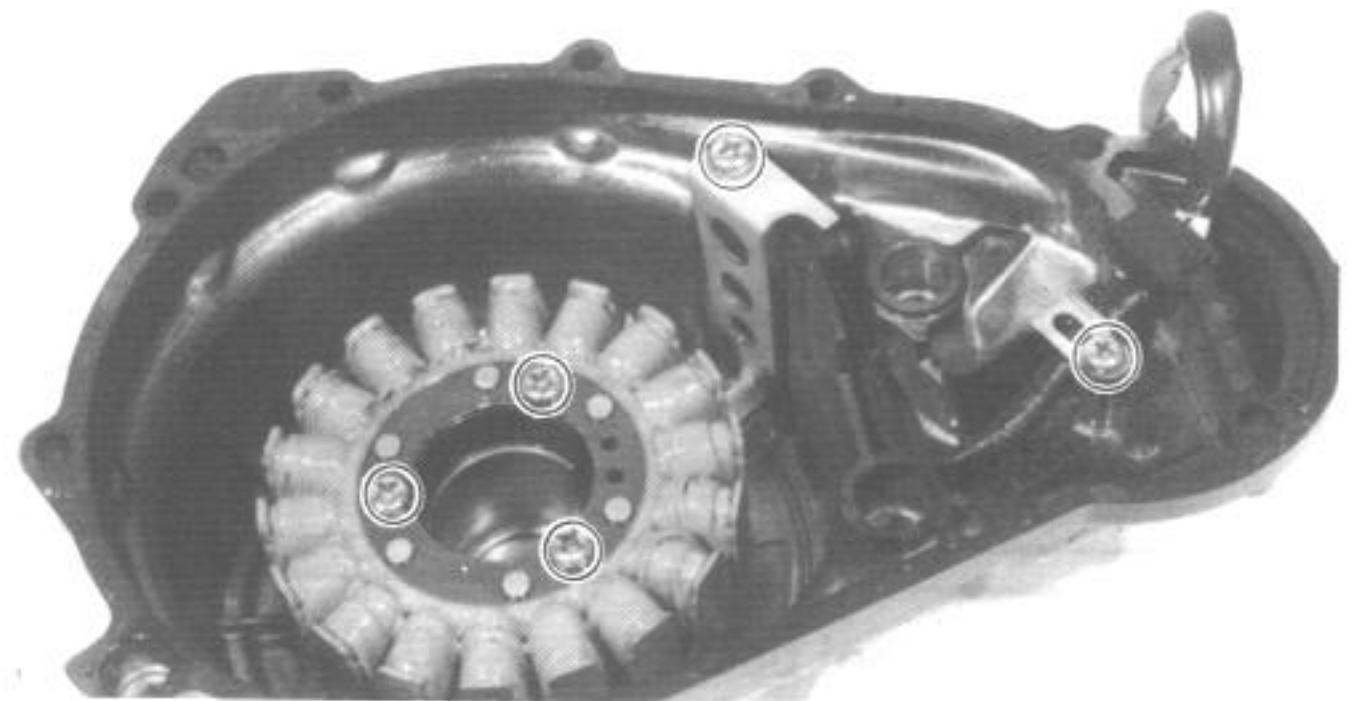

- Locate the shim ④ to the proper position.
- Apply THREAD LOCK SUPER "1303B" to allen bolts. Tighten its with specified torque while holding the rotor using by special tool and vise.

99000-32030	Thread lock super "1303B"
-------------	---------------------------

09914-25811	6 mm "T" type hexagon wrench
-------------	------------------------------

09930-44911	Rotor holder
-------------	--------------

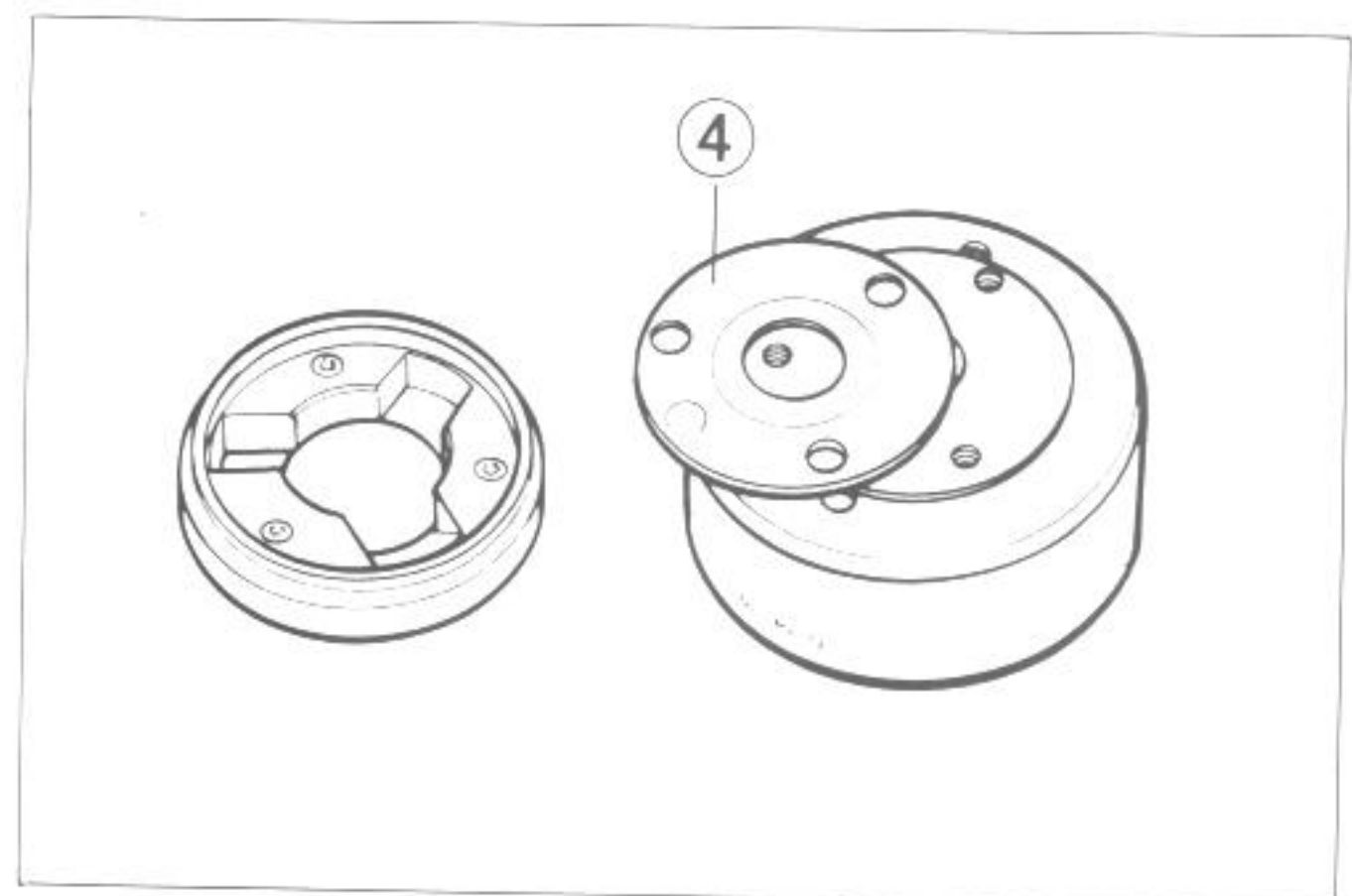

Tightening torque	23 – 28 N·m (2.3 – 2.8 kg-m)
-------------------	---------------------------------

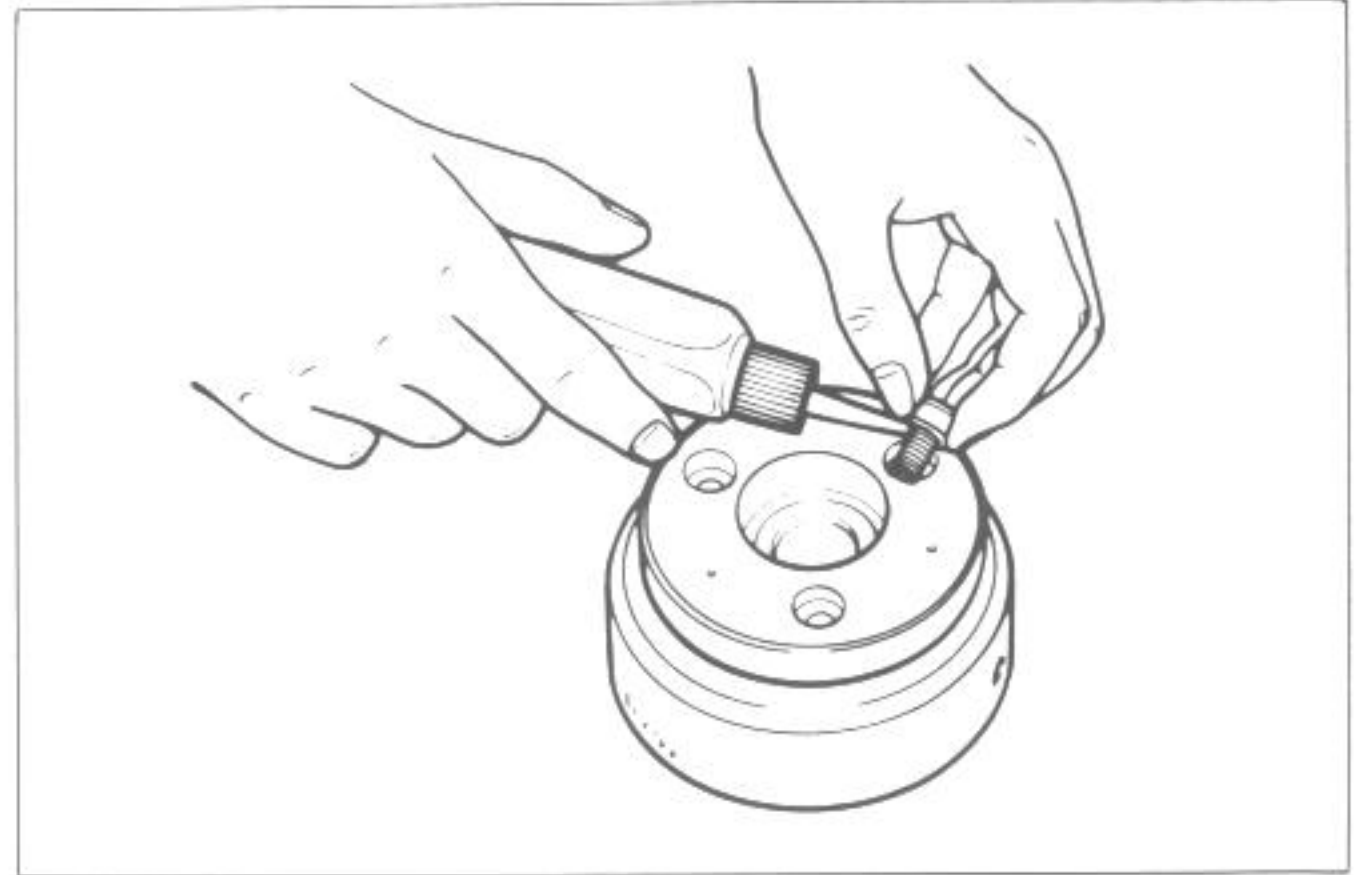

OIL PUMP

CAUTION:

The oil pump case securing screw is applied with SUZUKI THREAD LOCK SUPER "1303B". If an attempt is made to overhaul the oil pump assembly, the screw may be damaged. As a replacement, only the oil pump unit is available.

99000-32030	Thread lock super "1303B"
-------------	---------------------------

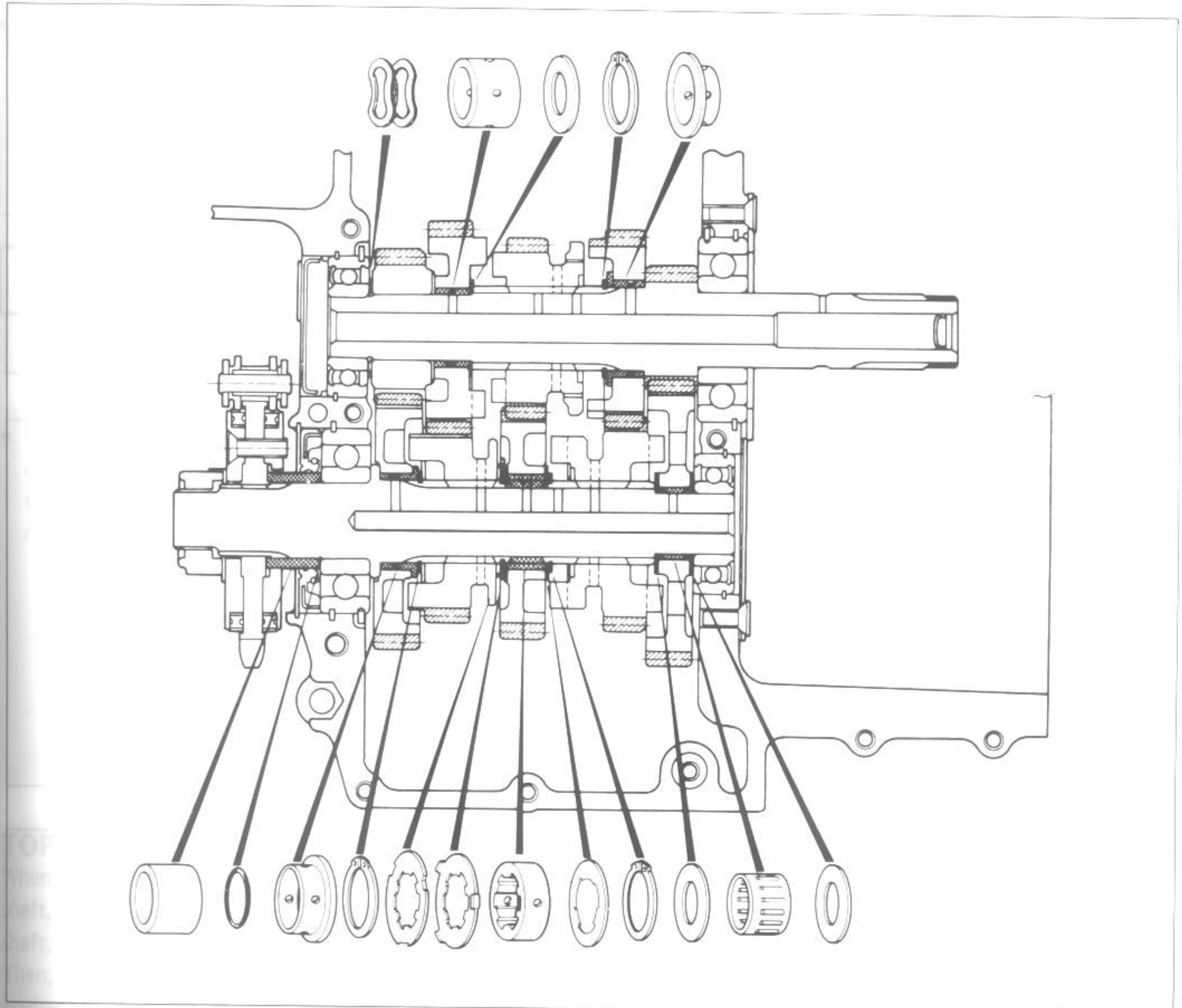

TRANSMISSION

**MOUNTING 2ND DRIVE GEAR**

Press the 2nd drive gear to a position where the distance between this drive gear and the 1st drive gear assumes the value indicated:

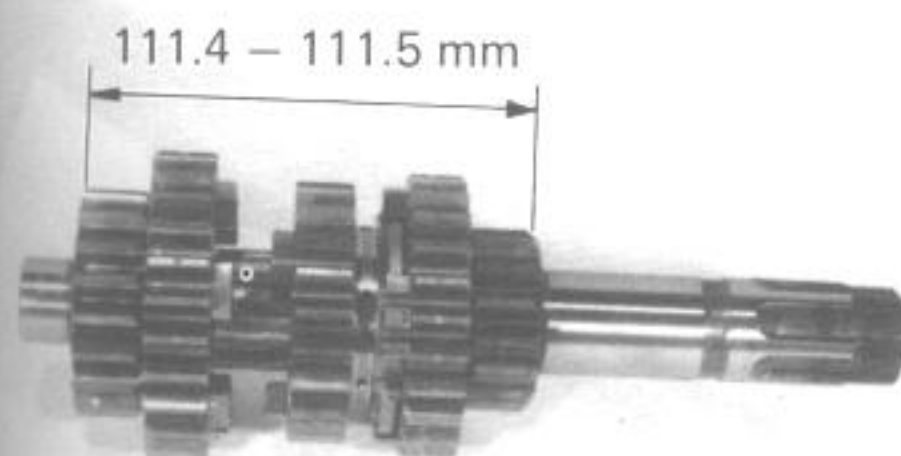

Countershaft length	111.4 – 111.5 mm
---------------------	------------------

99000-32100	Thread lock super "1305"
-------------	--------------------------

NOTE:

- * Before mounting the 2nd drive gear, apply **THREAD LOCK SUPER "1305"** to its bore, taking care not to smear Top drive gear with **SUPER "1305"**.
- * After mounting the 2nd drive gear, check that Top drive gear spins smoothly, by moving it with your fingers.
- * 2nd drive gear may be replaced twice before it becomes necessary to also replace the countershaft.

SHIFT FORK GROOVE CLEARANCE

Using a thickness gauge, check the shifting fork clearance in the groove of the gear.

This clearance for each of the three shifting forks plays an important role in the smoothness and positiveness of shifting action.

If the clearance checked is noted to exceed the limit specified, replace the fork or its gear, or both.

09900-20803	Thickness gauge
-------------	-----------------

Shift fork-Groove clearance

		Service Limit
No. 1	For 4th and Top driven gears	0.80 mm
No. 2	For 3rd drive gear	

Shift fork groove width

Standard	5.45 – 5.55 mm
----------	----------------

Shift fork thickness

Standard	4.95 – 5.05 mm
----------	----------------

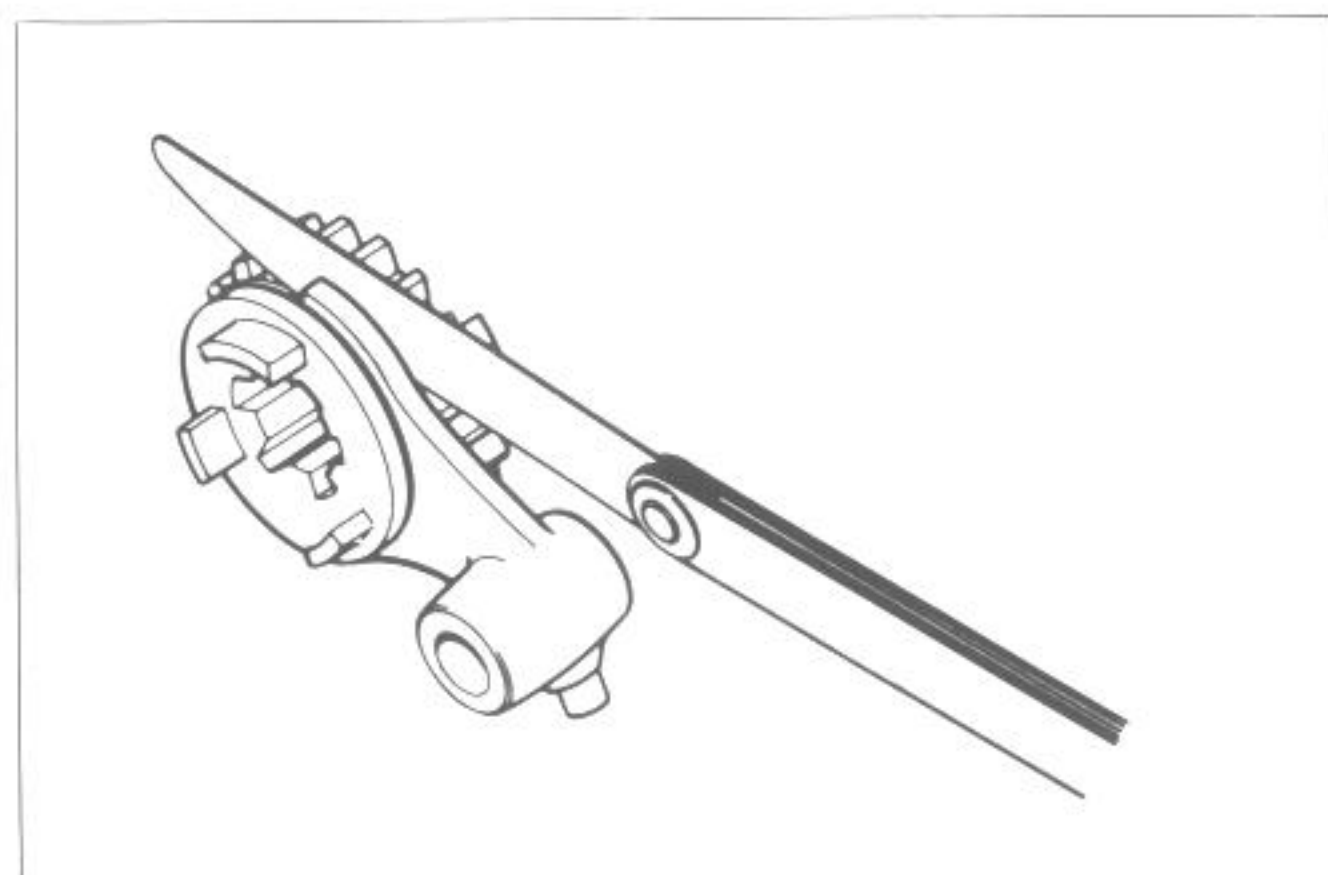

Checking clearance

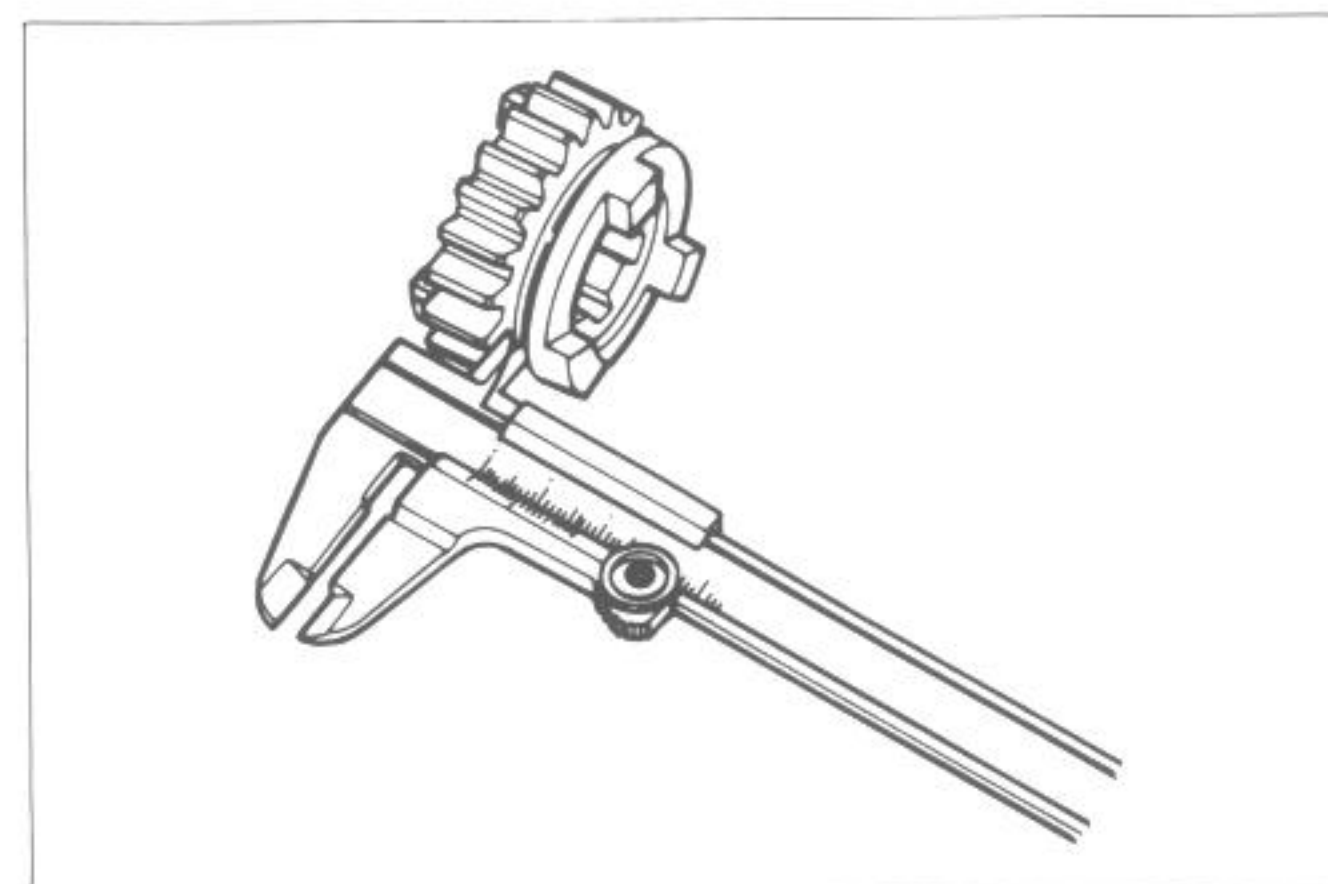

Checking groove width

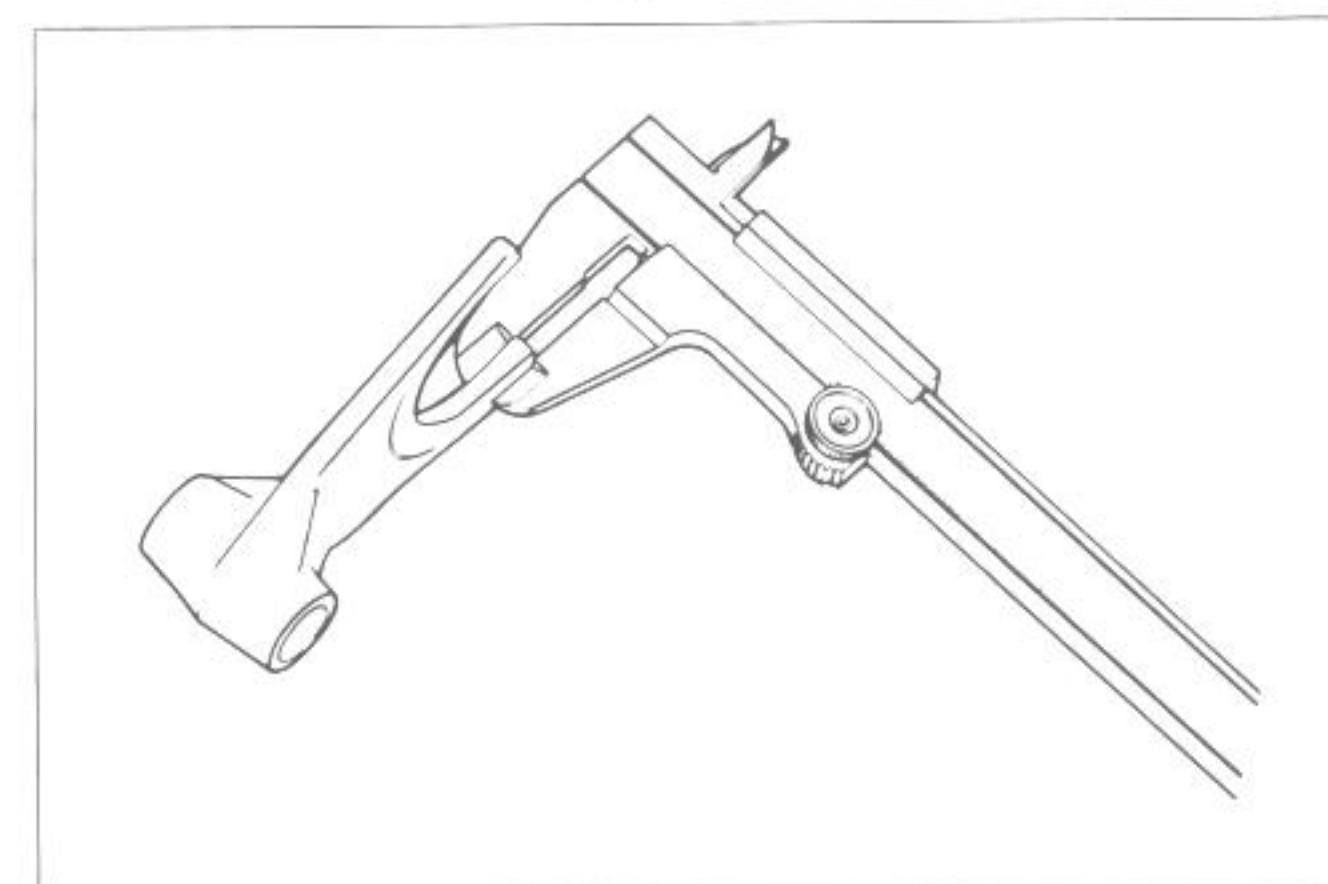

Checking thickness

TRANSMISSION GEAR ASSEMBLY

- Using bearing installing tool, install the drive shaft bearing.

09913-84510	Bearing installer
-------------	-------------------

- Fix O-ring ① to the drive shaft.

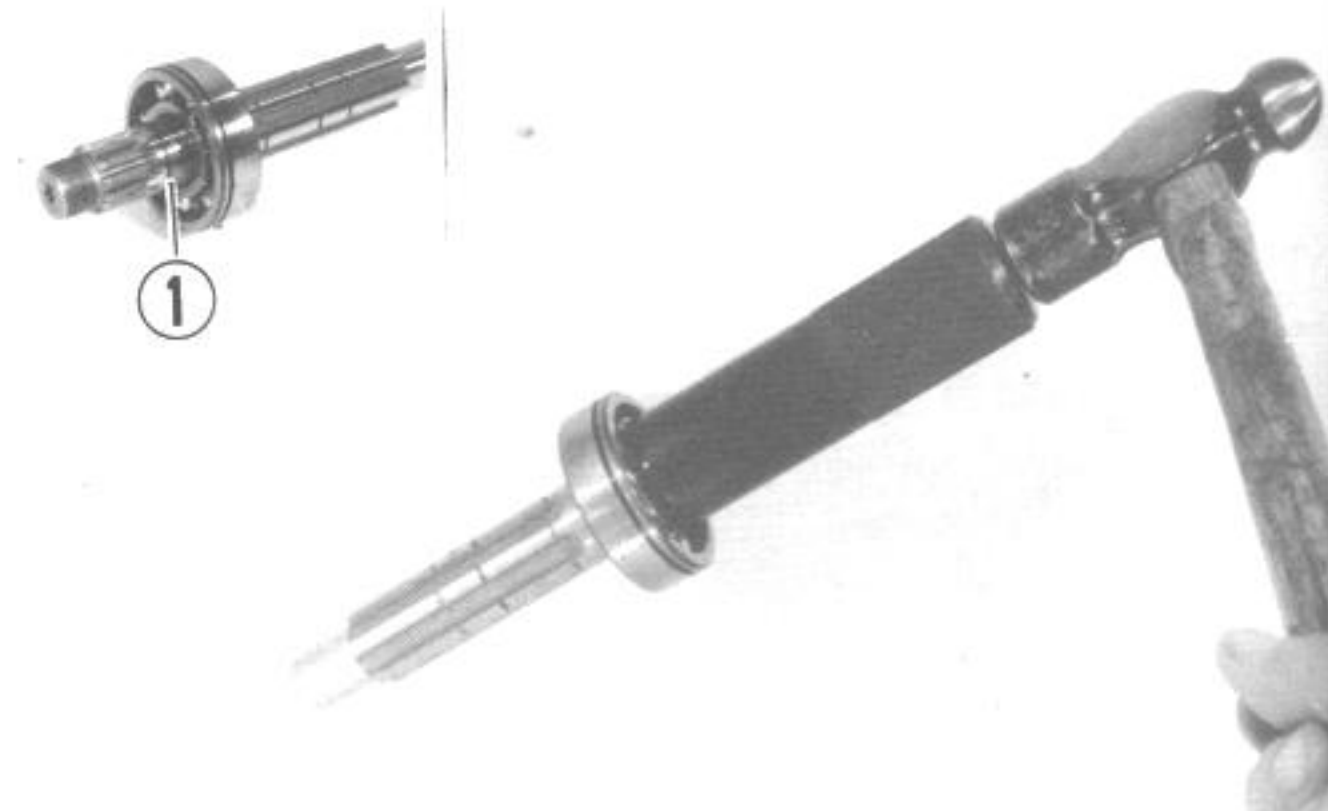

- Mount the 2nd driven gear and its bushing on the drive shaft.

NOTE:

Before mounting the gears, coat lightly moly paste to the drive shaft.

99000-25140

SUZUKI Moly paste

- When mounting the circlip, pay attention to the direction of the circlip. Fit it to the side where the thrust is as shown in the figure with the rounded side against the gear surface.

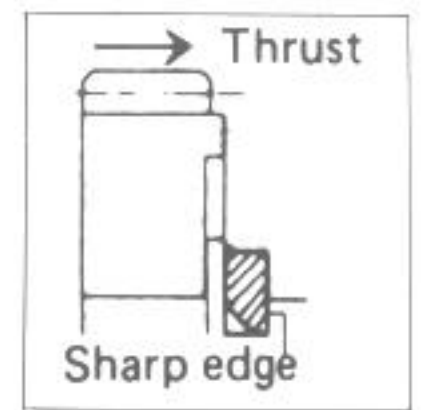

TOP DRIVEN GEAR

When mounting the top driven gear on the drive shaft, insert lock washer No. 2 ① into the drive shaft, and turn and fit it into the groove.

Then, fit the lock washer No. 1 ② in the lock washer No. 2.



3RD DRIVEN GEAR

- When installing the 3rd driven gear bushing, align its oil hole ③ with drive shaft oil hole ④.

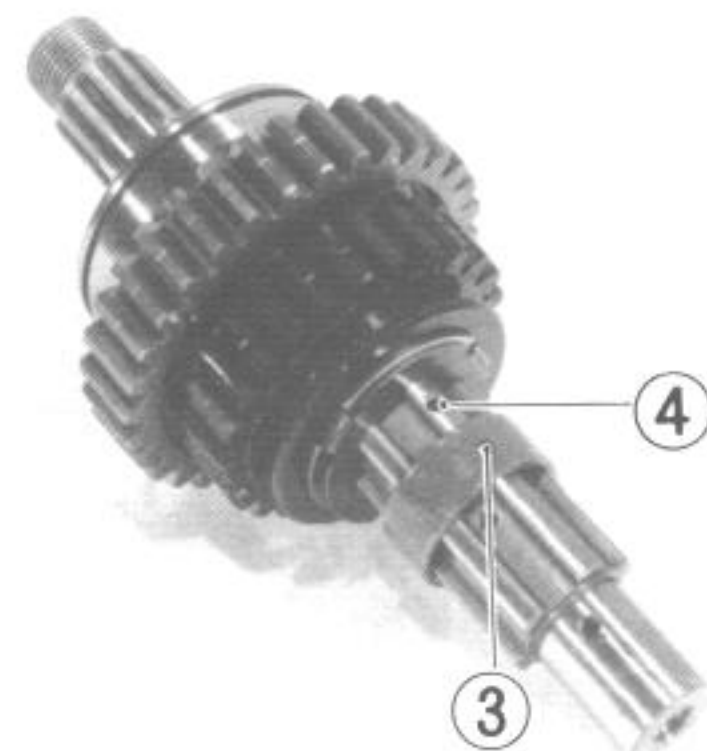

- Fix the washer ① and lock it by circlip ②.
- Mount 4th driven gear, and fix washer ③ and bearing ④.

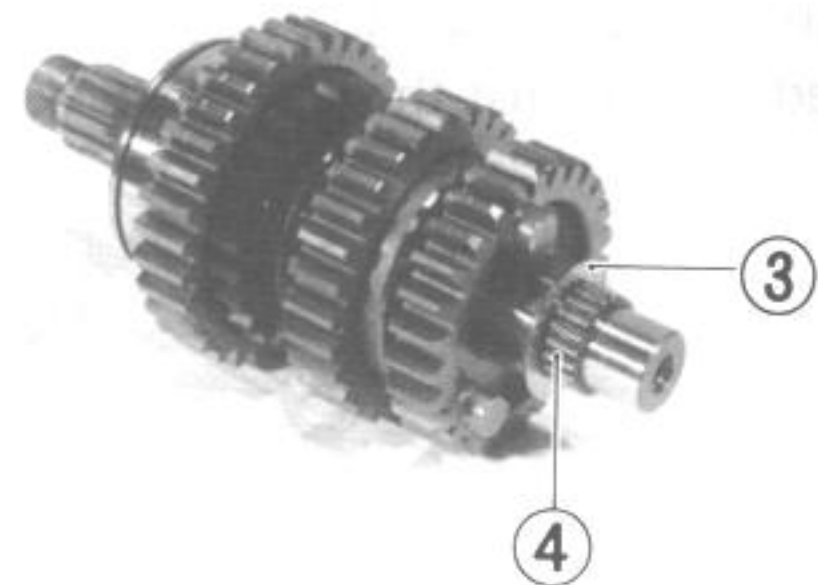
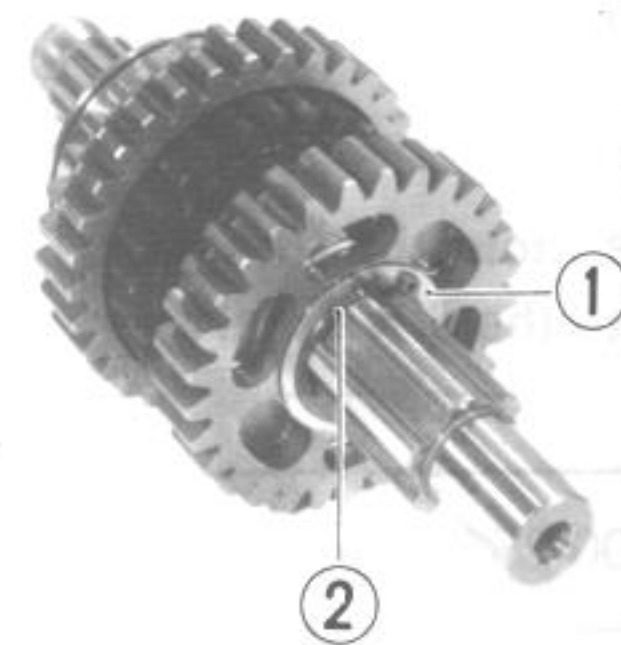

- After mounting Low driven gear and washer ⑤, fit bearing to the drive shaft by using bearing installer.

09913-80112	Bearing installer
-------------	-------------------

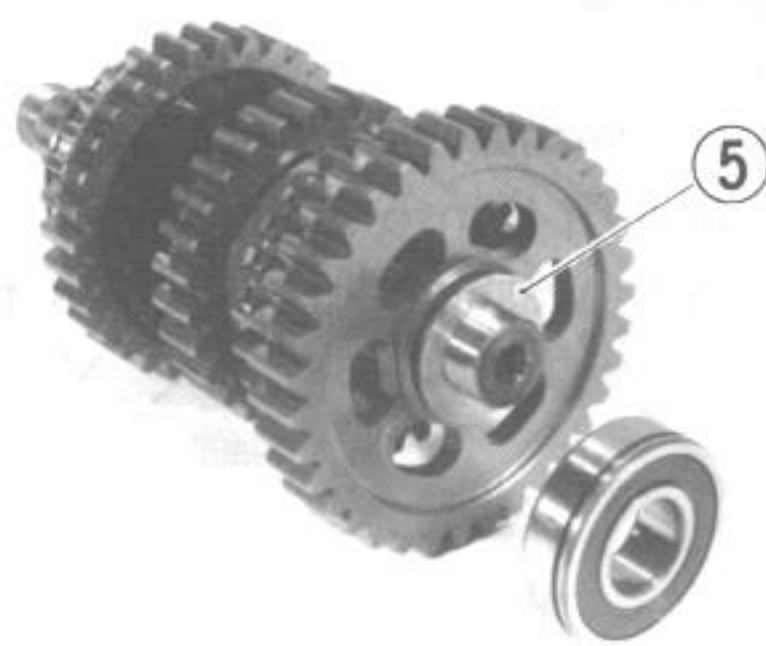

- Coat SUZUKI super grease "A" to the lip of oil seal.

99000-25010	SUZUKI Super grease "A"
-------------	-------------------------

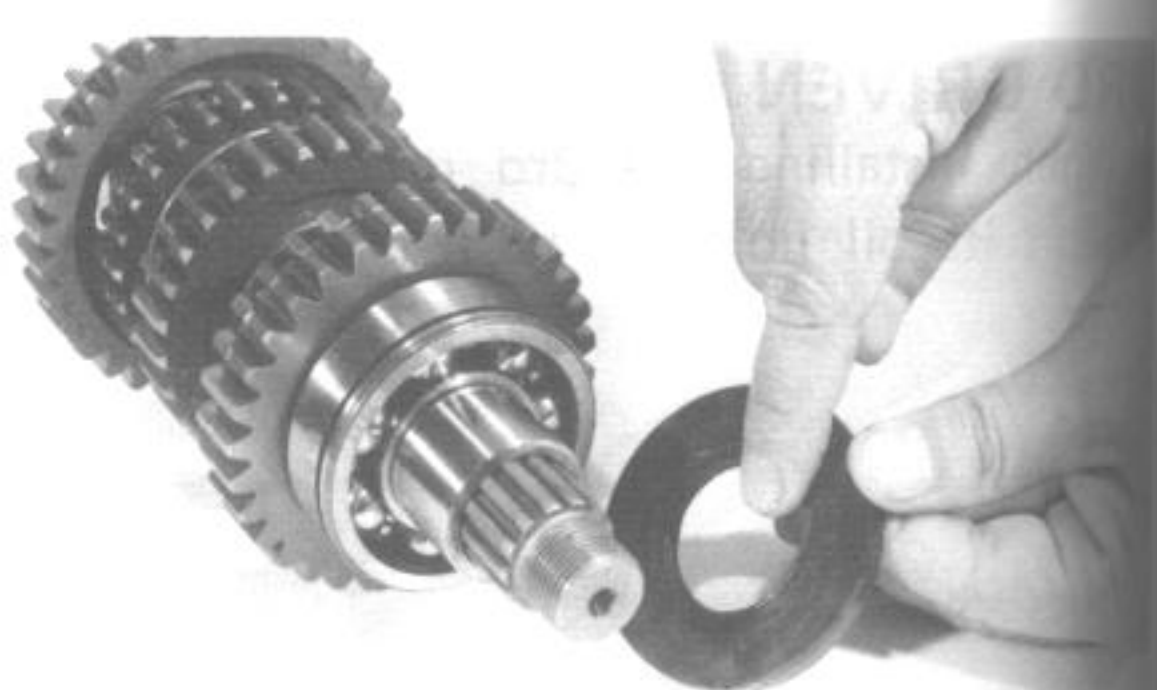

ENC
The
numb
NOTE
Before
parts
9800
When mounting
Direct
the
round
Tight
torq
Inst
4, 6
The
fere
wid
• Mou
gear
• Mou
case
NOT
Neve
• Usin
the g
099

ENGINE REASSEMBLY

The engine is reassembled by carrying out the steps of disassembly in the reversed order, but there are a number of steps which demand special descriptions or precautionary measures.

NOTE:

Apply engine oil to each running and sliding part before reassembling.

- Apply the SUZUKI BOND No. 1207B to the thread of No. 2, 4, 6, 7 and 8 stud bolts lightly as shown in illustration.

99000-31140	SUZUKI Bond No. 1207B
-------------	-----------------------

- Tighten the stud bolts to the specification.

Tightening torque	No. 2, 4, 6, 7 and 8	16 N·m (1.6 kg-m)
	The others	10 – 16 N·m (1.0 – 1.6 kg-m)

- Install the O-rings to the four stud bolts (No. 2, 4, 6 and 8).

- The shape of each gear shifting pawl is different. Mount the one with the narrower width on the gear shifting cam side.
- Mount the gear shifting cam stopper on the gearshiting cam as shown.

- Mount the gearshifting cam on the lower crank-case.

NOTE:

Never fail to fix circlip and bearing ①.

- Using snapping pliers, fix circlip in the groove of the gearshifting cam.

09900-06107	Snapping pliers
-------------	-----------------

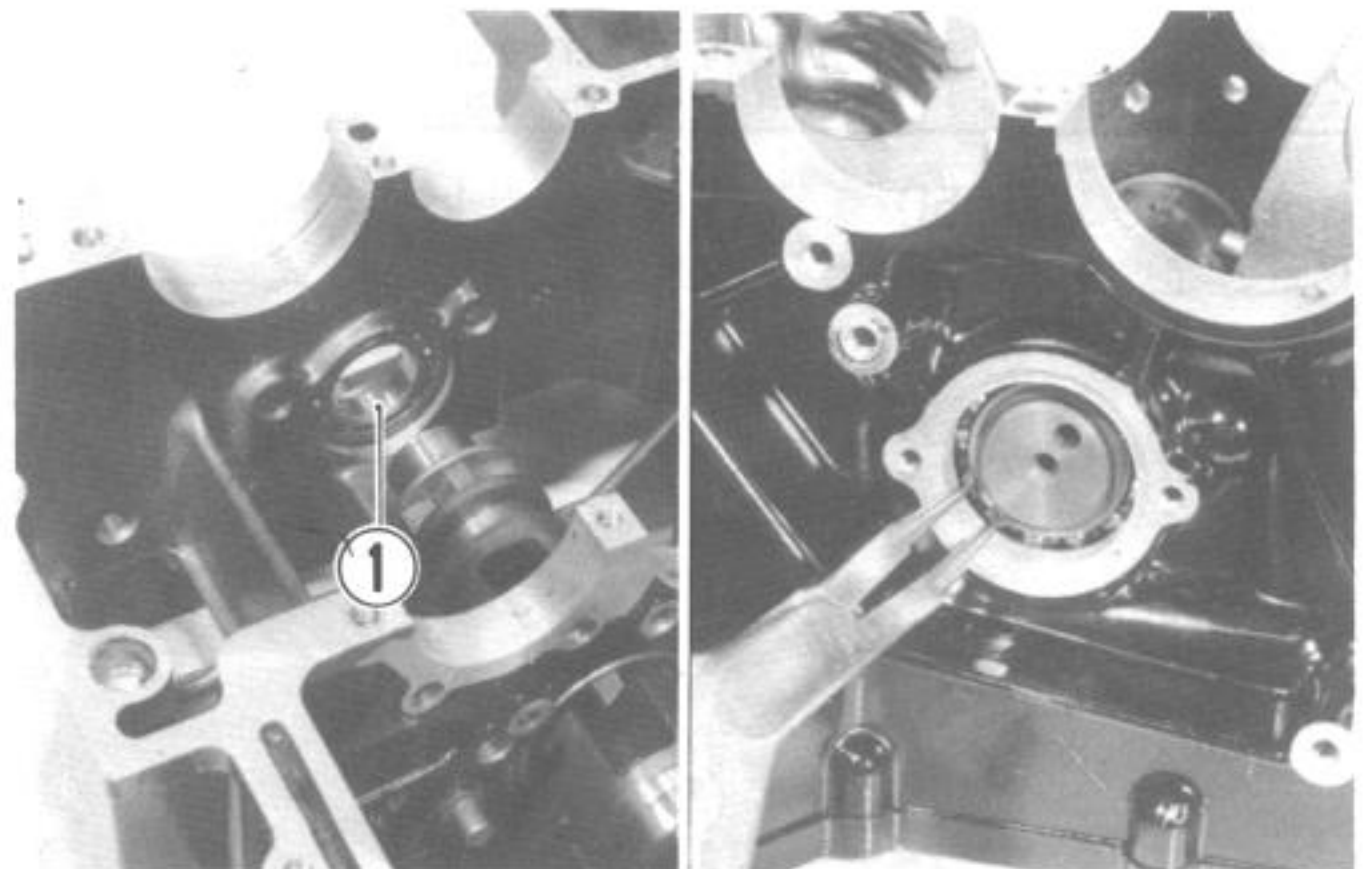
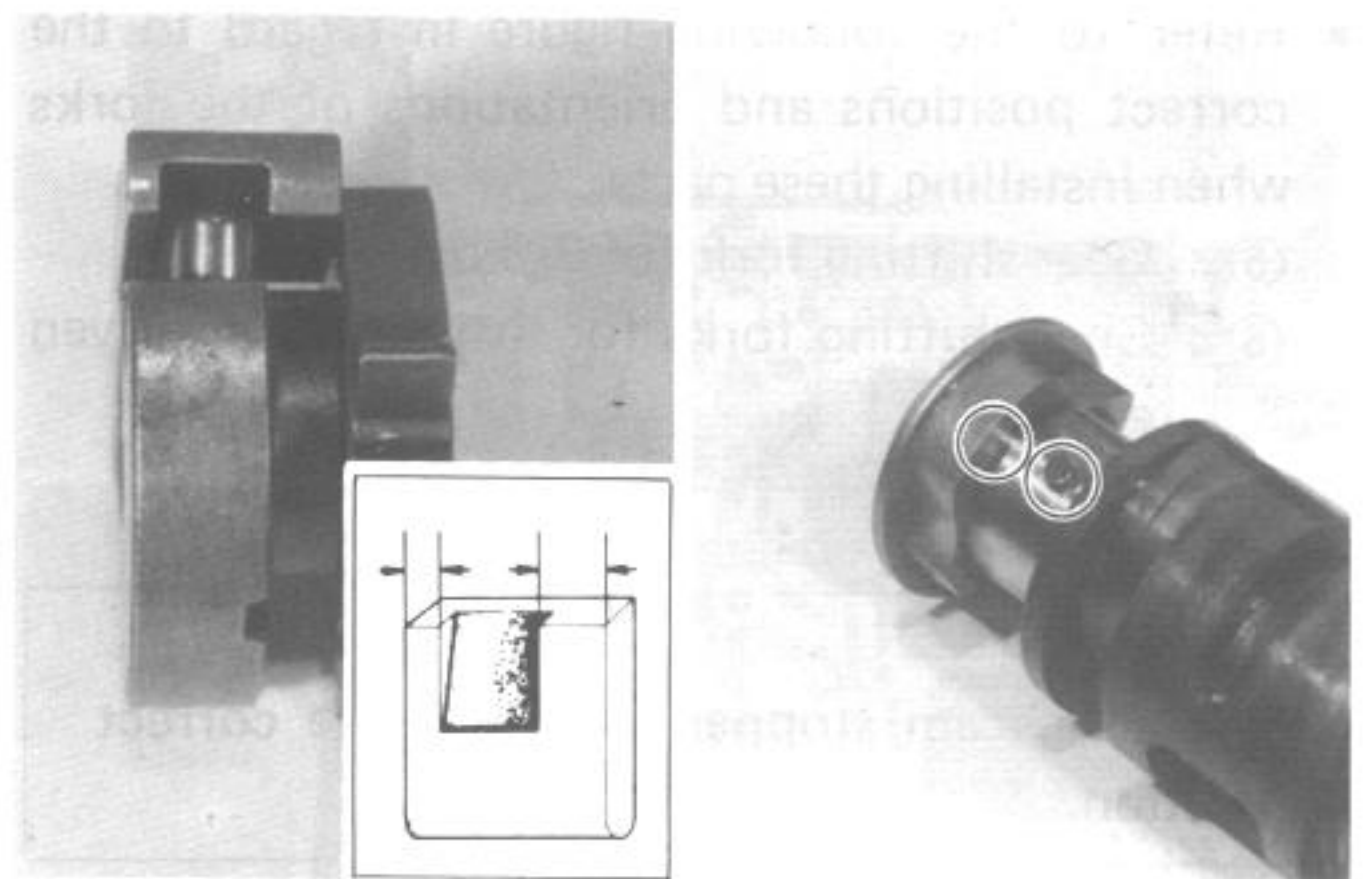
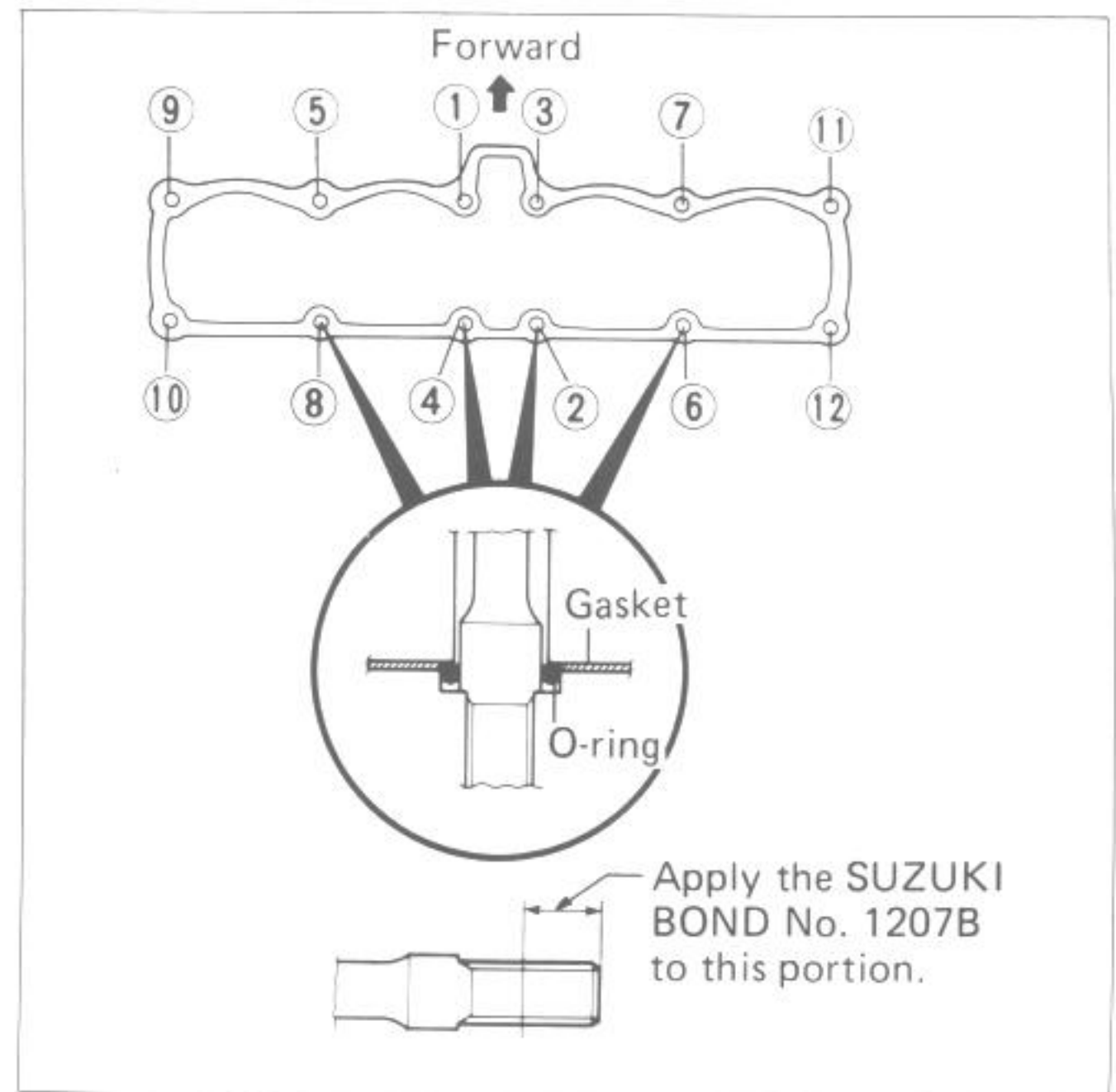

- Install the gearshifting cam with the dent for the neutral stopper directed downward, and meet the neutral stopper ① with this dent ②.
- Tighten the neutral stopper bolt ③ to the specification.

Tightening torque	18 – 28 N·m (1.8 – 2.8 kg-m)
-------------------	---------------------------------

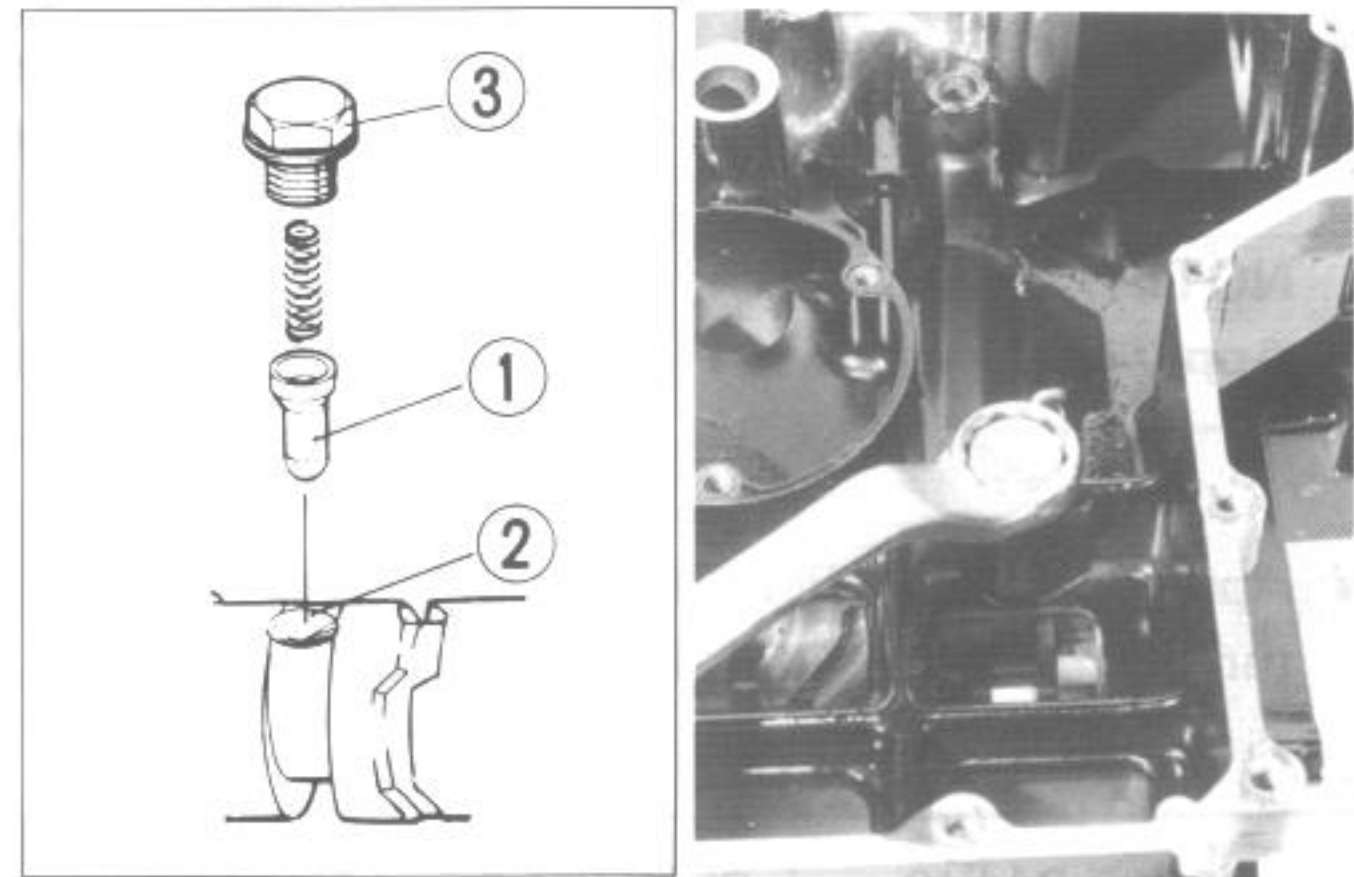

- Install the sump filter to face the oil inlet ④ to the front.
- Apply Thread lock "1342" to the screws.

99000-32050	Thread lock "1342"
-------------	--------------------

NOTE:
Check the four oil passage holes (A).

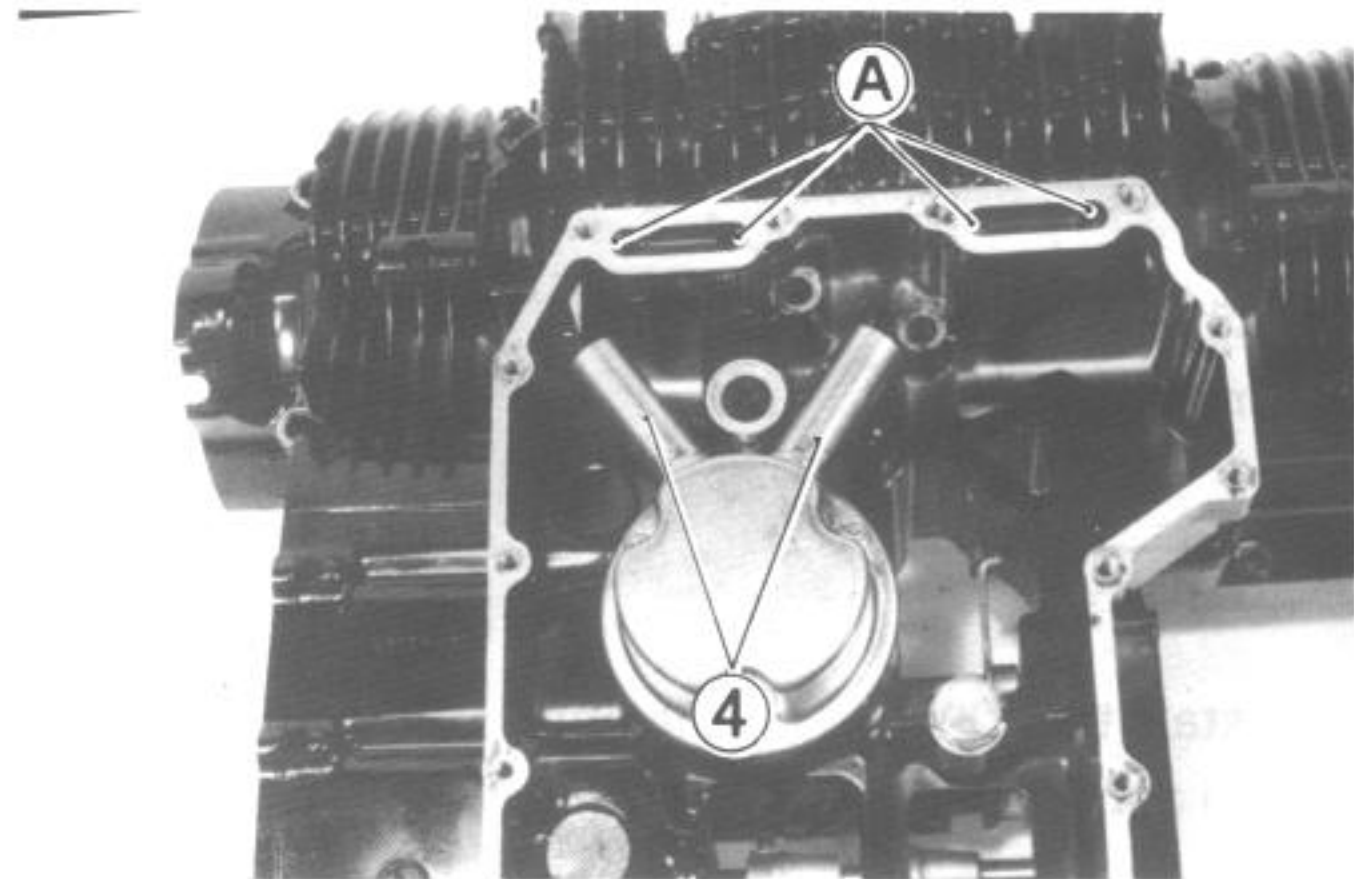

- Refer to the following figure in regard to the correct positions and orientations of the forks when installing these parts.
 - ⑤ : Gear shifting fork for 3rd drive gear.
 - ⑥ : Gear shifting forks for 4th and Top driven gears.
 - ⑦ : Cam stopper.

NOTE:
Hitch the cam stopper spring to the correct position.

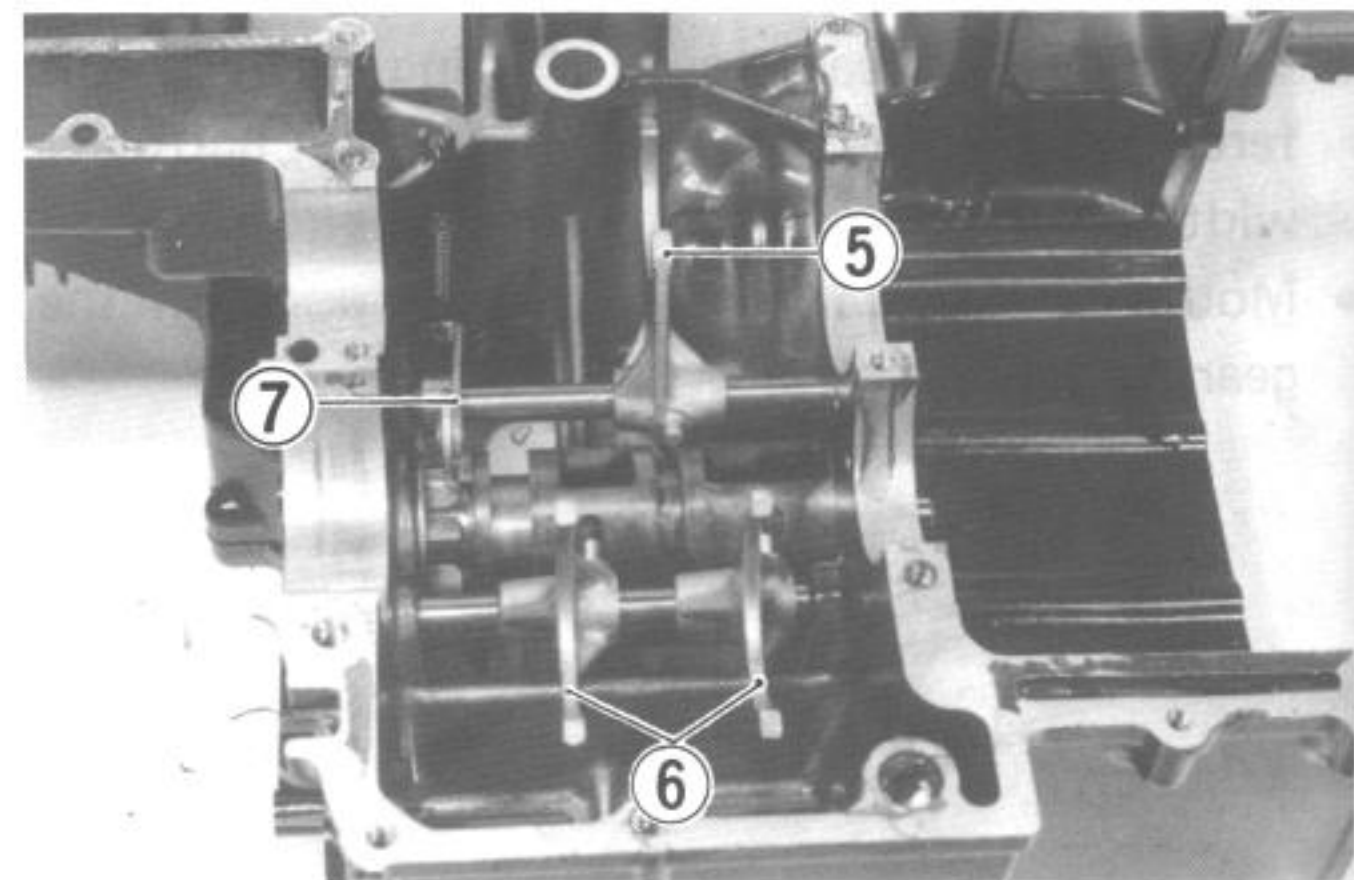

- Install both gearshift cam guide and gearshift pawl screws with applying thread lock "1342".

99000-32050	Thread lock "1342"
-------------	--------------------

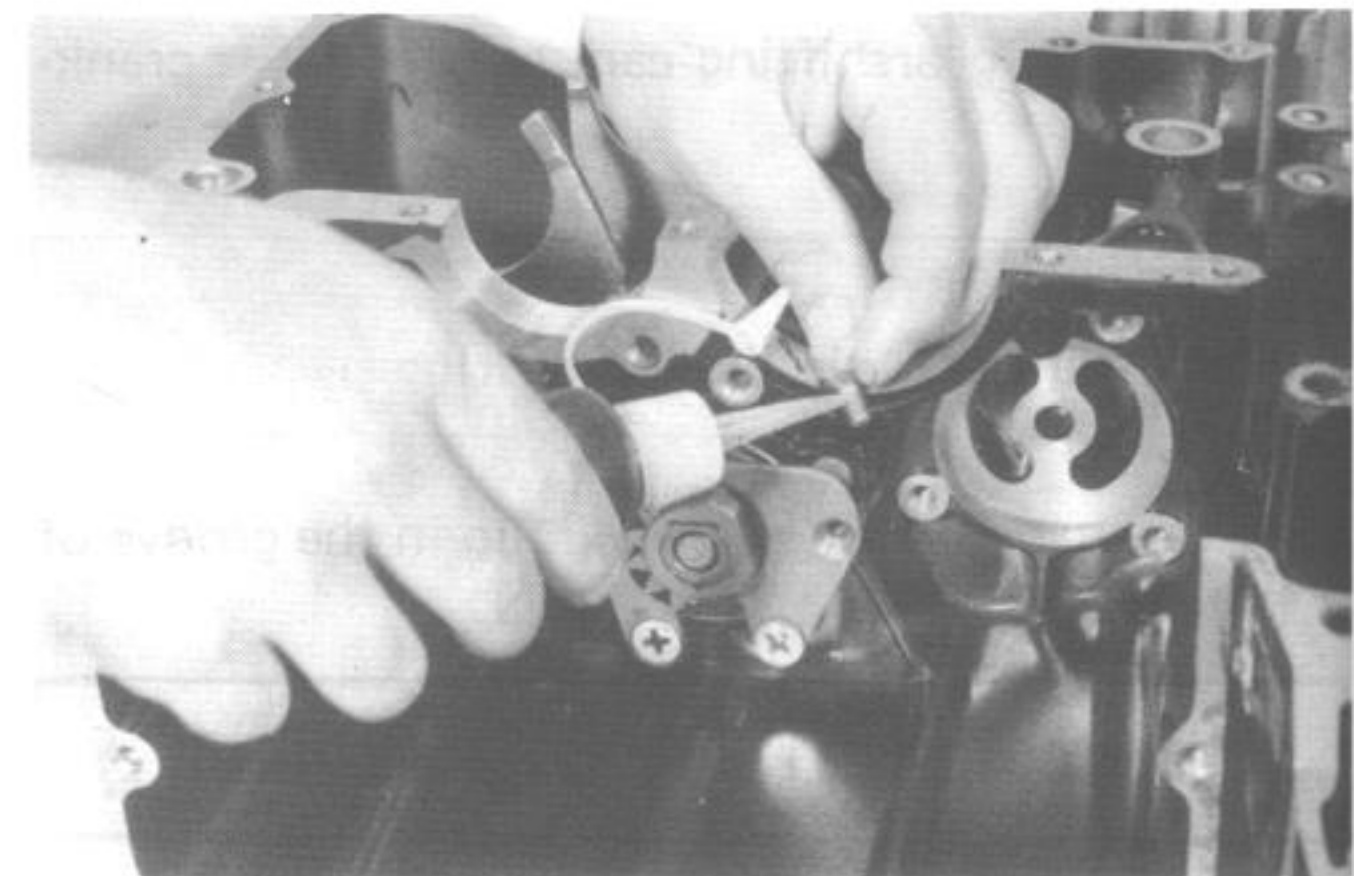

- Check oil jet fitted on the upper crankcase for clogging.

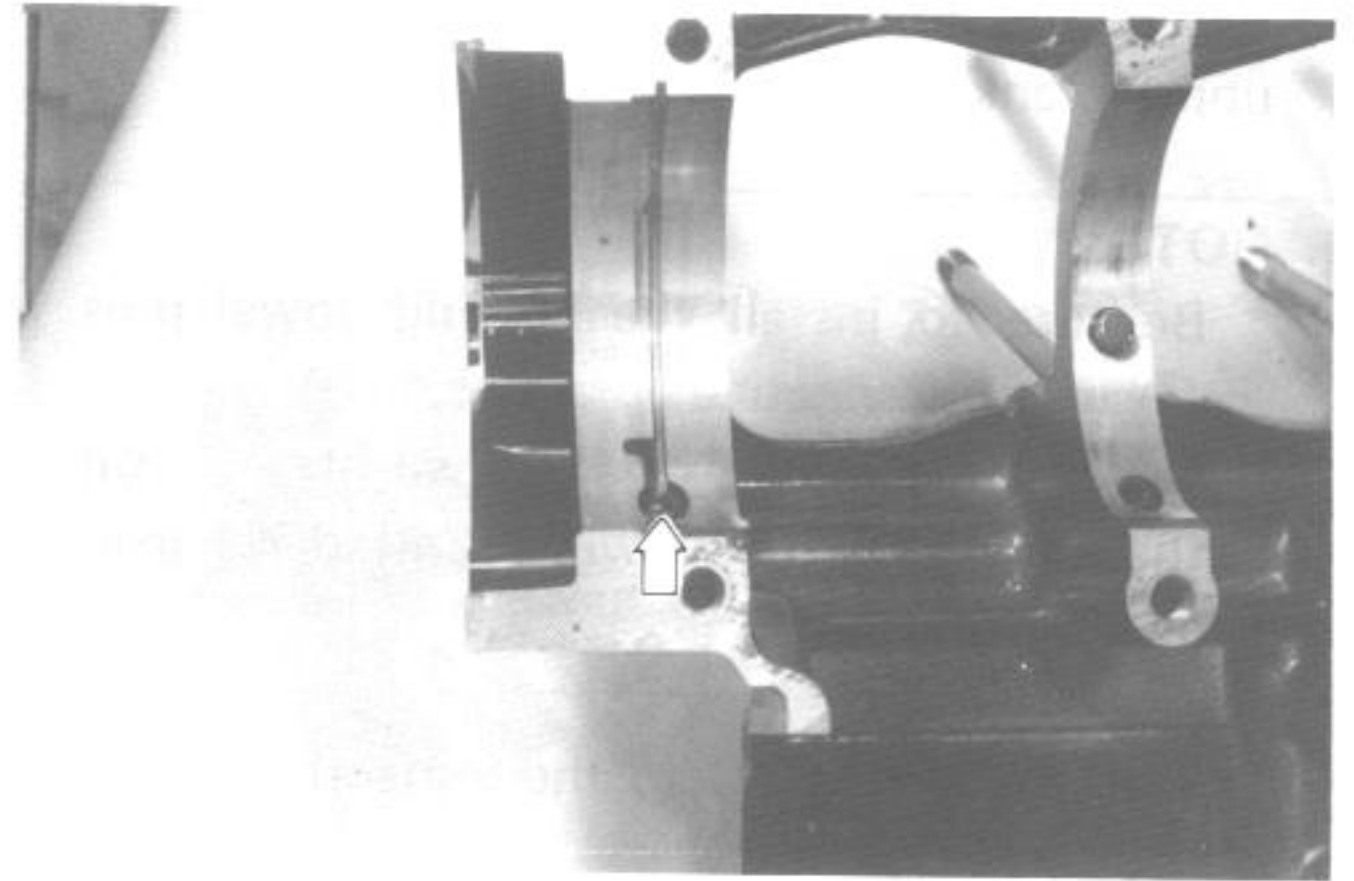

- Firmly insert crankshaft bearing locating pins ① and C-ring ② to upper crankcase.

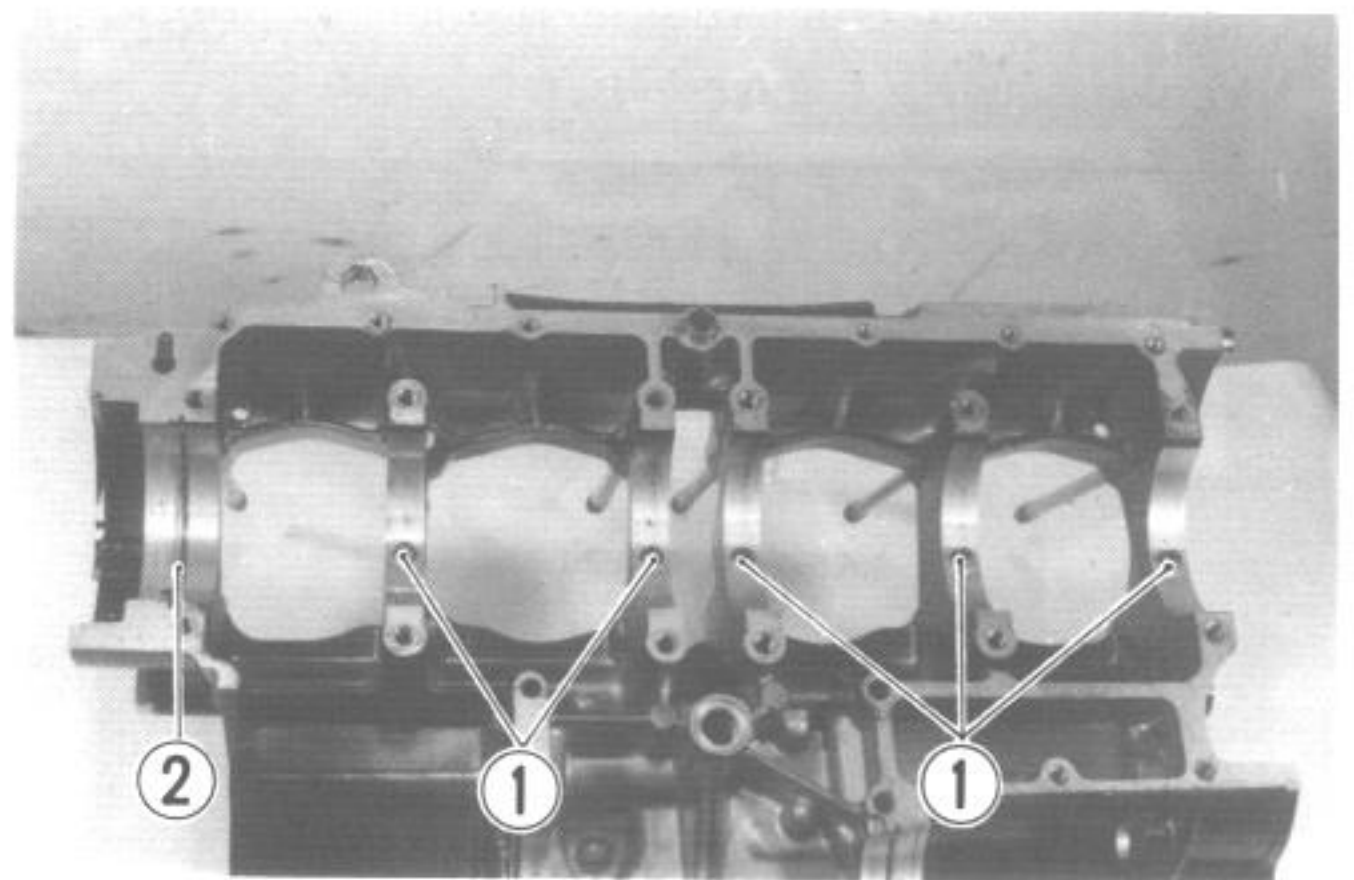

- Mount the crankshaft on the upper crankcase. At this time firmly fit each bearing onto the locating pin with punch mark stamped on the circumference of the bearing directed upwards.
- Bearing stopper pin ③ should be in the position shown.

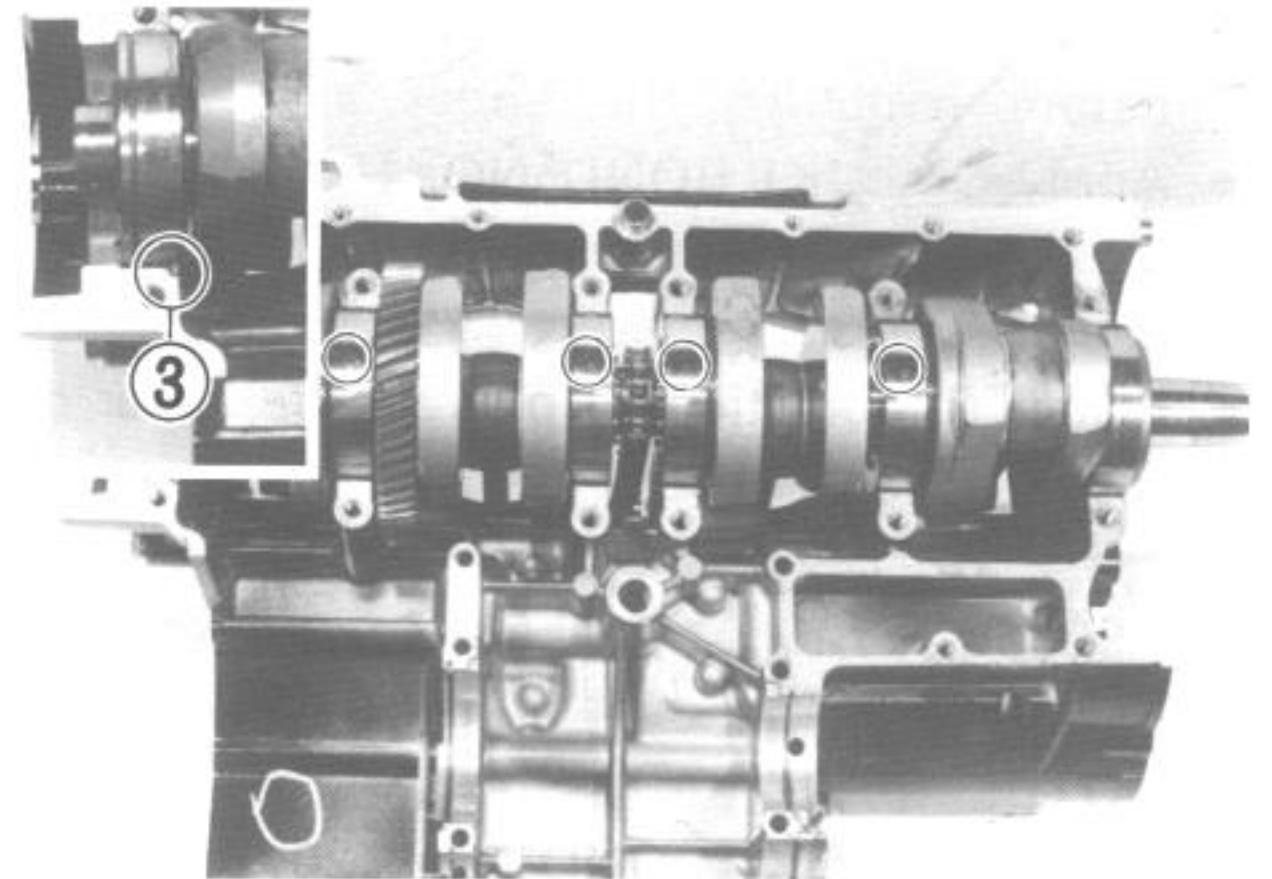

- Install five C-rings ④ to the upper crankcase.

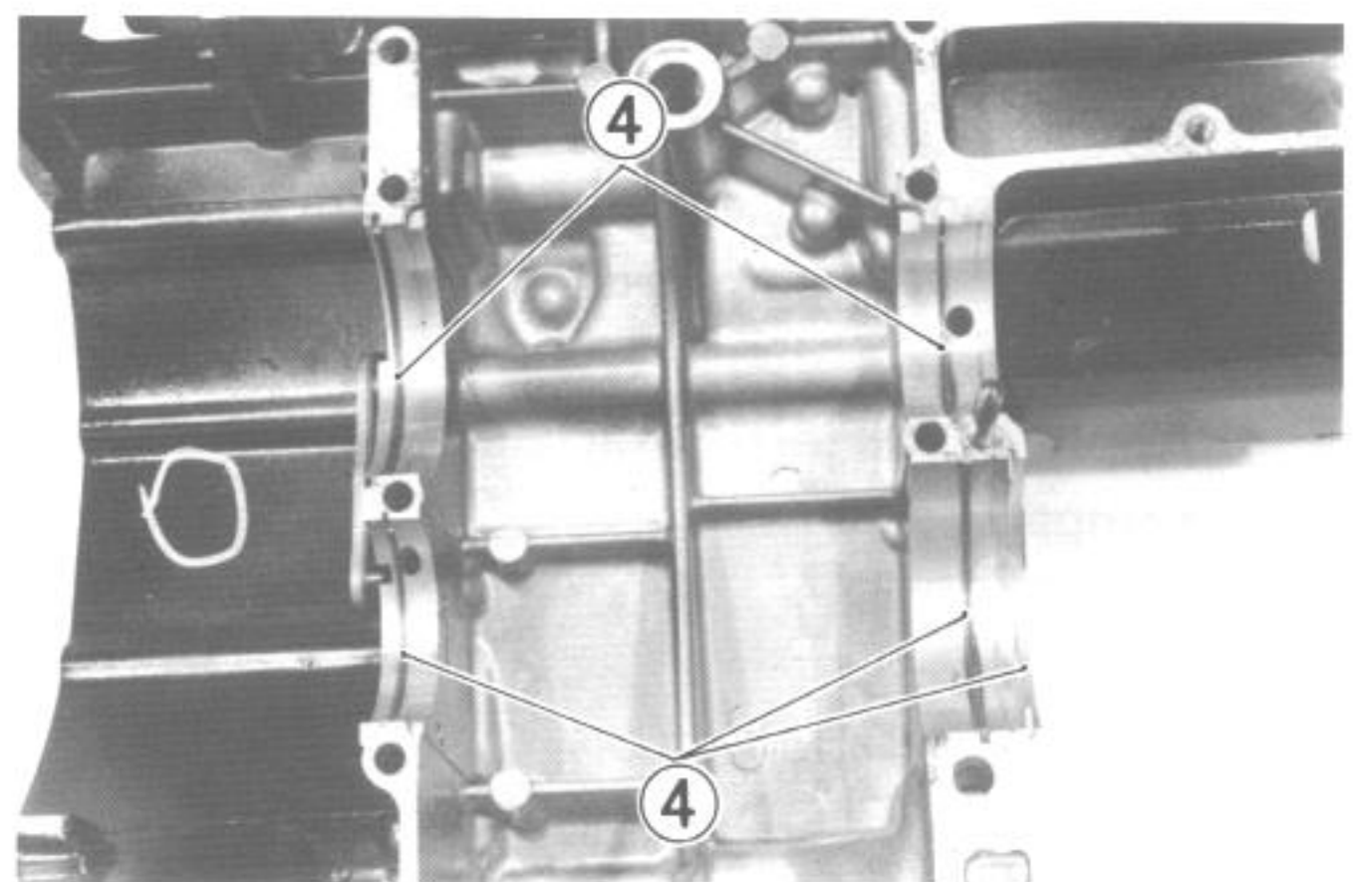

- Mount the both counter and drive shafts on the upper crankcase.

NOTE:

- * Be sure to install the bearing dowel pins ① in the respective positions.
- * Never fail to fix two wave washers ② on the countershaft between 2nd drive gear and bearing.

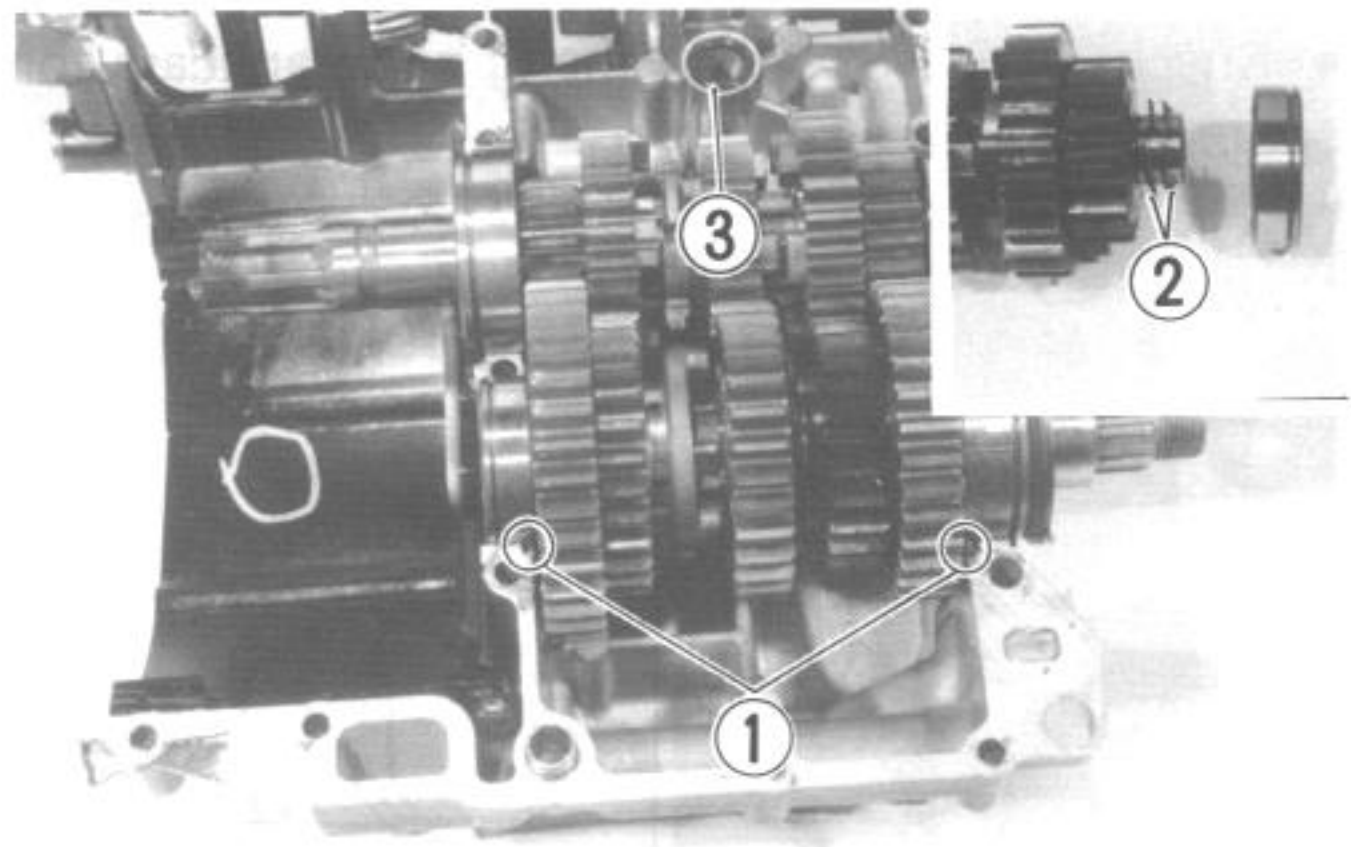

- Locate the O-ring ③ to the respective position.
- Fix the cam chain guide holder to the lower crankcase with two screws.

99000-32020	Thread lock super "1333B"
-------------	---------------------------

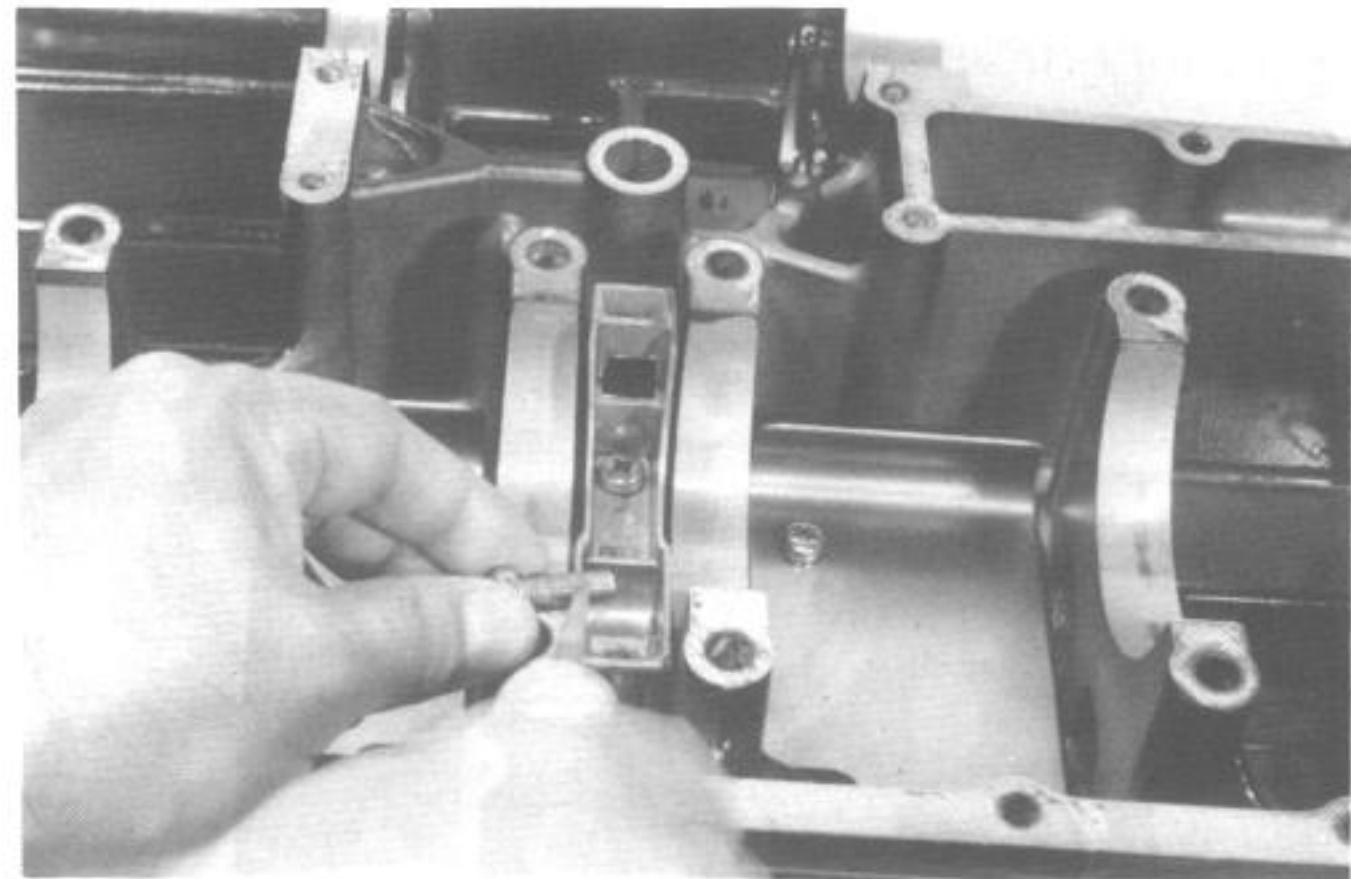

- Clean the mating surfaces of the crankcases before matching the upper and lower ones.
- Apply SUZUKI BOND NO. 1207B to the mating surface of the lower crankcase in the following procedure.
- Install the positioning pins to the upper crankcase.

99000-31140	SUZUKI Bond No. 1207B
-------------	-----------------------

NOTE:

Use of SUZUKI BOND NO. 1207B is as follows:

- * Make surfaces free from moisture, oil, dust and other foreign materials.
- * Spread on surfaces thinly to form an even layer, and assemble the cases within few minutes.
- * Apply to distorted surface as it forms a comparatively thick film.

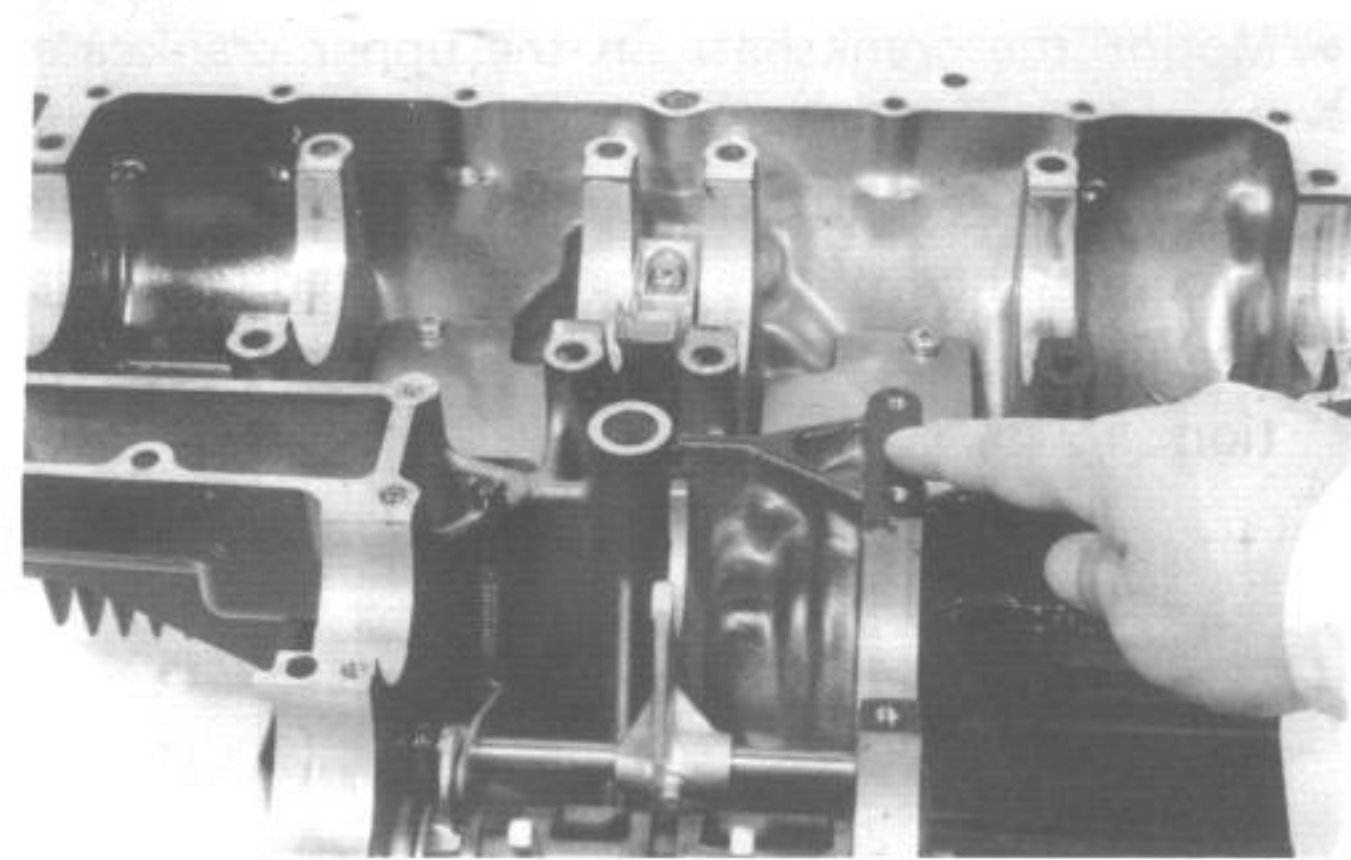

• W
8
o
ir
p
sp

In

Fi

C
P

N
A
in

• L
m

Tig

• Ti
to
pr

Ti
to

- When securing the lower crankcase, tighten the 8-mm bolts and the 6-mm bolts in the ascending order of numbers assigned to these bolts, tightening each bolt a little at a time to equalize the pressure. Tighten all the securing bolts to the specified torque values.

Tightening torque		6 mm bolt	8 mm bolt
Initial	N·m	6	13
	kg·m	0.6	1.3
Final	N·m	9 – 13	20 – 24
	kg·m	0.9 – 1.3	2.0 – 2.4

CAUTION:
Place O-ring ① to the position shown.

NOTE:
Apply engine oil to the bolt ④ before installing.

- Locate the oil pan and new gasket, and tighten 6 mm bolts with specified torque.

Tightening torque	10 N·m (1.0 kg·m)
-------------------	----------------------

- Tighten the upper crankcase bolts with specified torque. Fix the engine ground wire at the proper position ②.

Tightening torque	6 mm	9 – 13 N·m (0.9 – 1.3 kg·m)
	8 mm	20 – 24 N·m (2.0 – 2.4 kg·m)

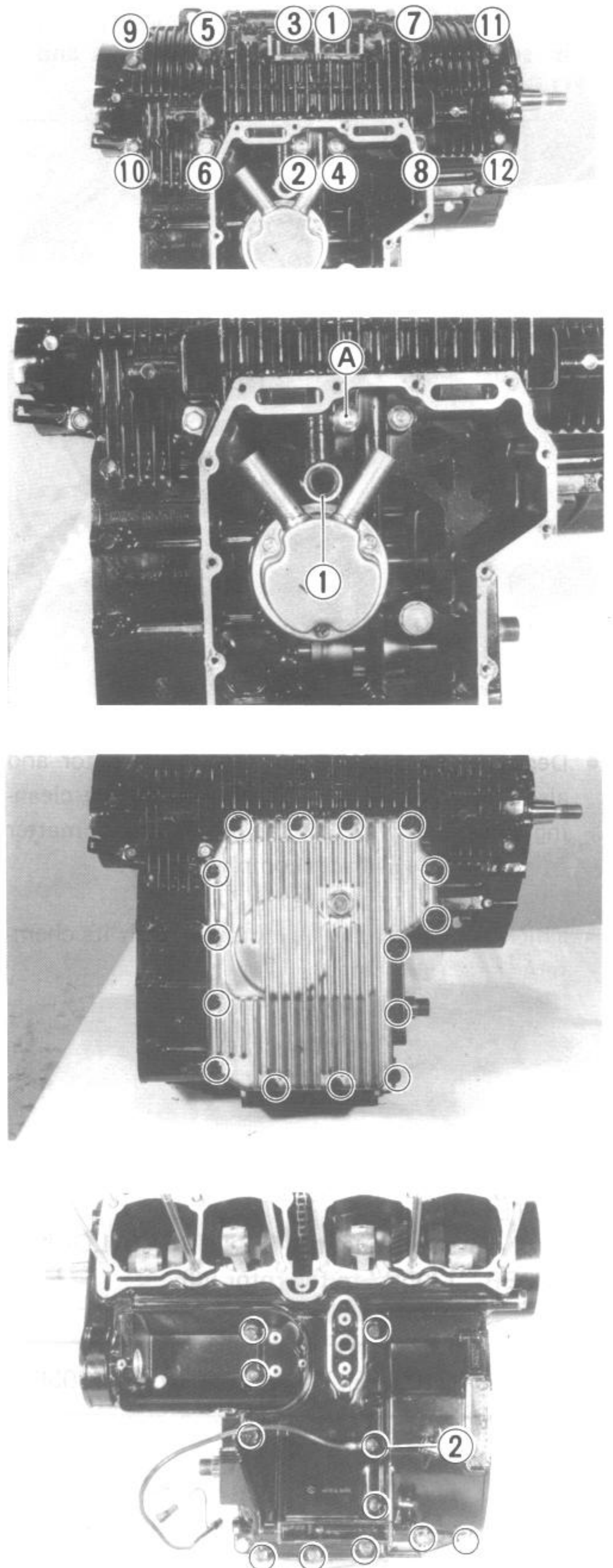

- Tighten the crankcase securing nut ① and install neutral indicator switch.

NOTE:
When installing the neutral indicator switch, be sure to locate spring, switch contact and O-ring ② .

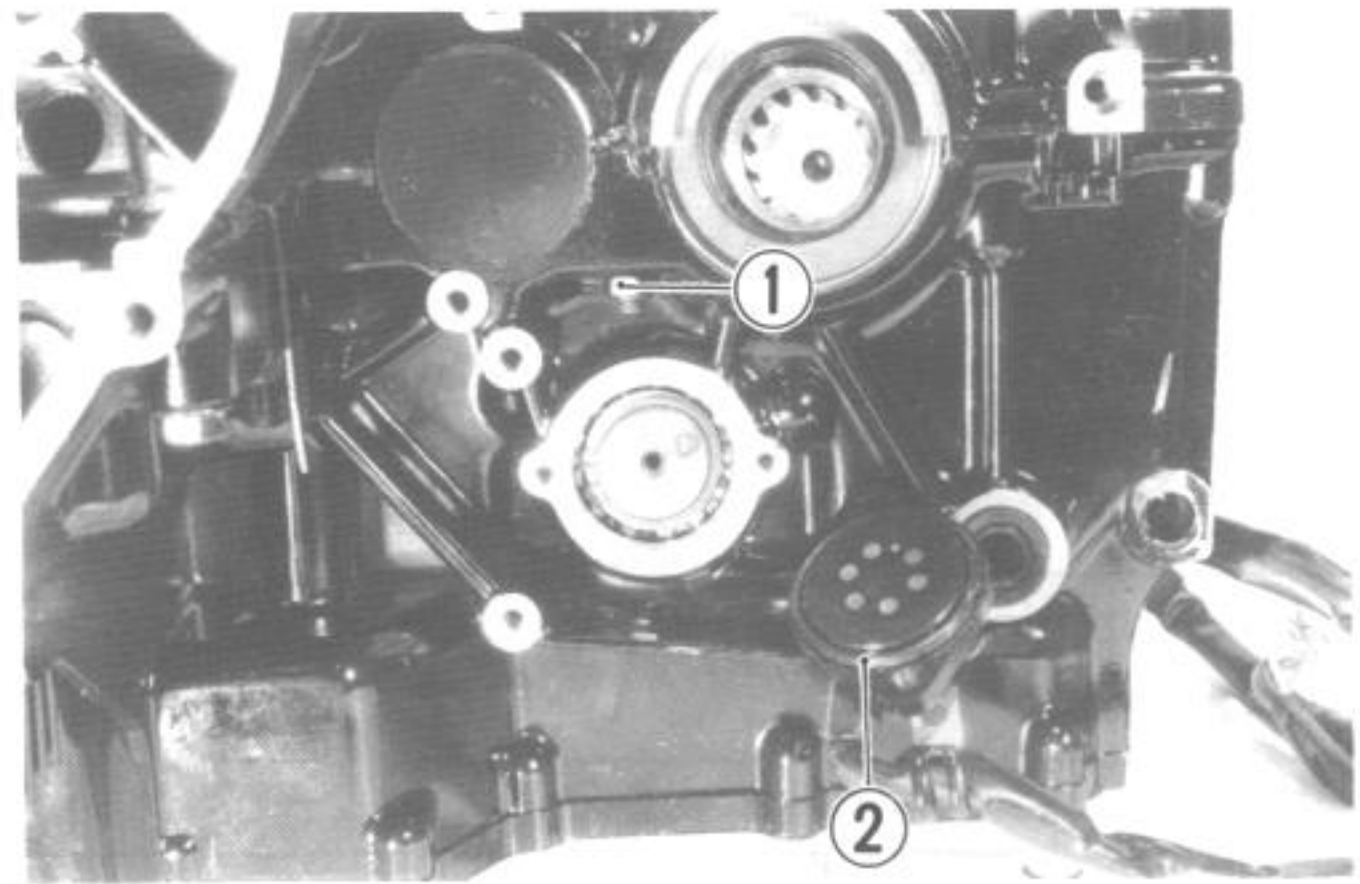

- Route the gear position indicator lead wire ③ and clamp it with countershaft oil seal retainer ④ .

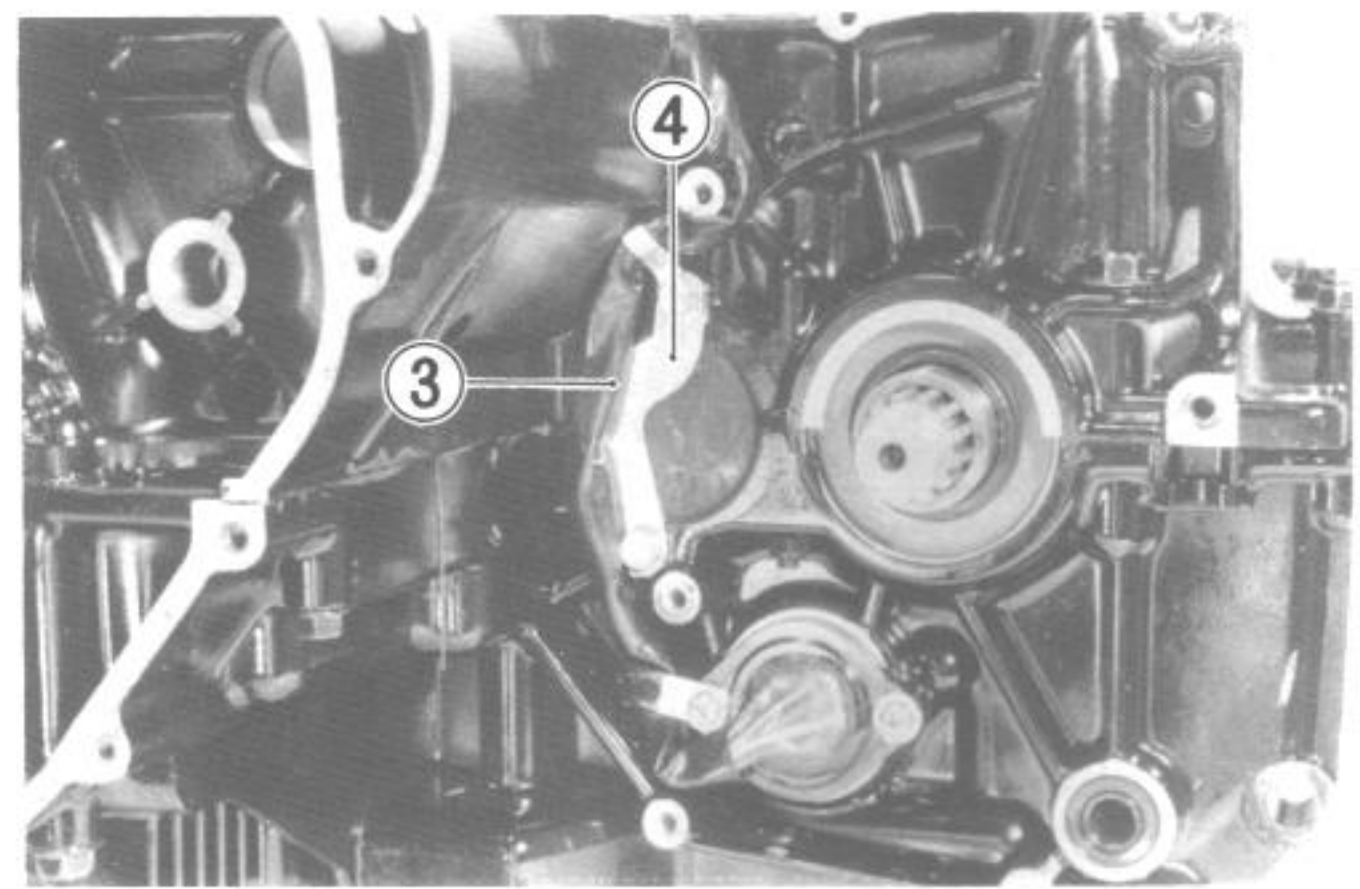

- Degrease the tapered portion of the rotor and also the crankshaft. Use non-flammable cleaning solvent to wipe off the oily or greasy matter to make these surfaces completely dry.
- Thick copper washer is mounted with its chamfered side ⑤ facing in.

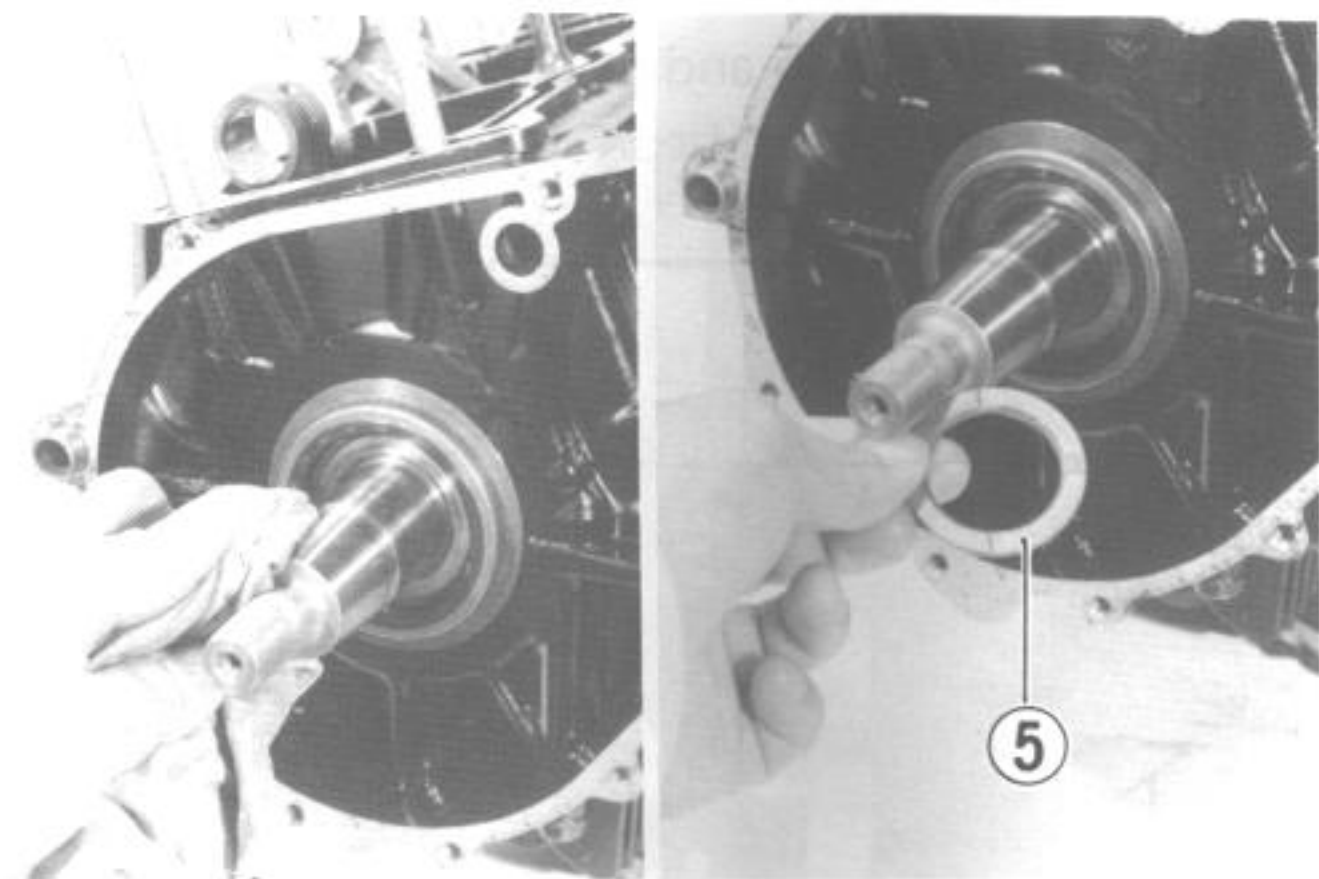

NOTE:
Apply a small quantity of **THREAD LOCK SUPER "1305B"** to the rotor nut.

99000-32100	Thread lock super "1305B"
-------------	---------------------------

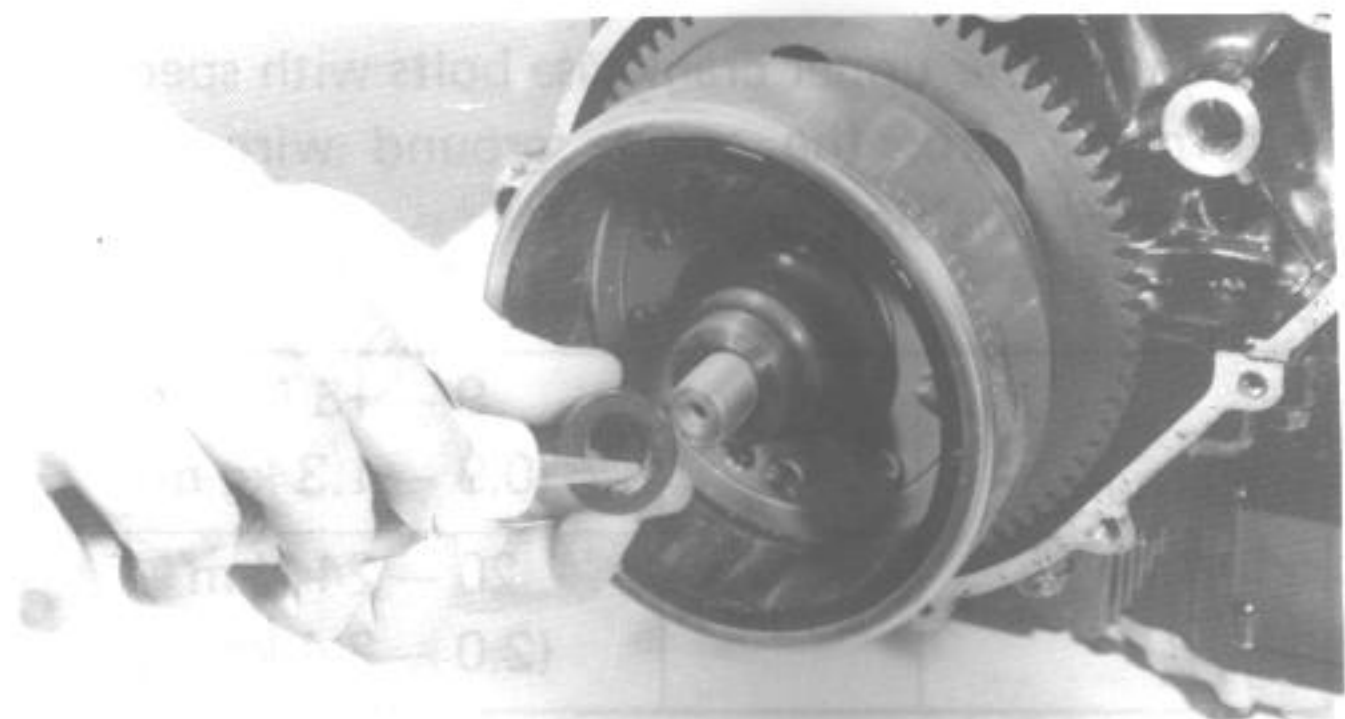

- After mounting the rotor, secure the rotor by tightening the center nut to the specification.

Tightening torque	160 – 170 N·m (16.0 – 17.0 kg-m)
-------------------	-------------------------------------

09910-20116	Con-rod stopper
09930-44911	Rotor holder

CAUTION:
To prevent the damage to the connecting rod bearing, hold the rotor by using the rotor holder ① when finally tighten the rotor nut.

- Install the starter idle gear and its shaft.

- Coat SUZUKI Bond No. 1207B lightly to the portion around mating surface between upper and lower crankcase as shown.

99000-31140	SUZUKI Bond No. 1207B
-------------	-----------------------

- Pass the generator stator lead wire through gasket and upper crankcase. Route its lead wire and fit rubber pad ② properly.

NOTE:
Always use new gasket and install knock pin.

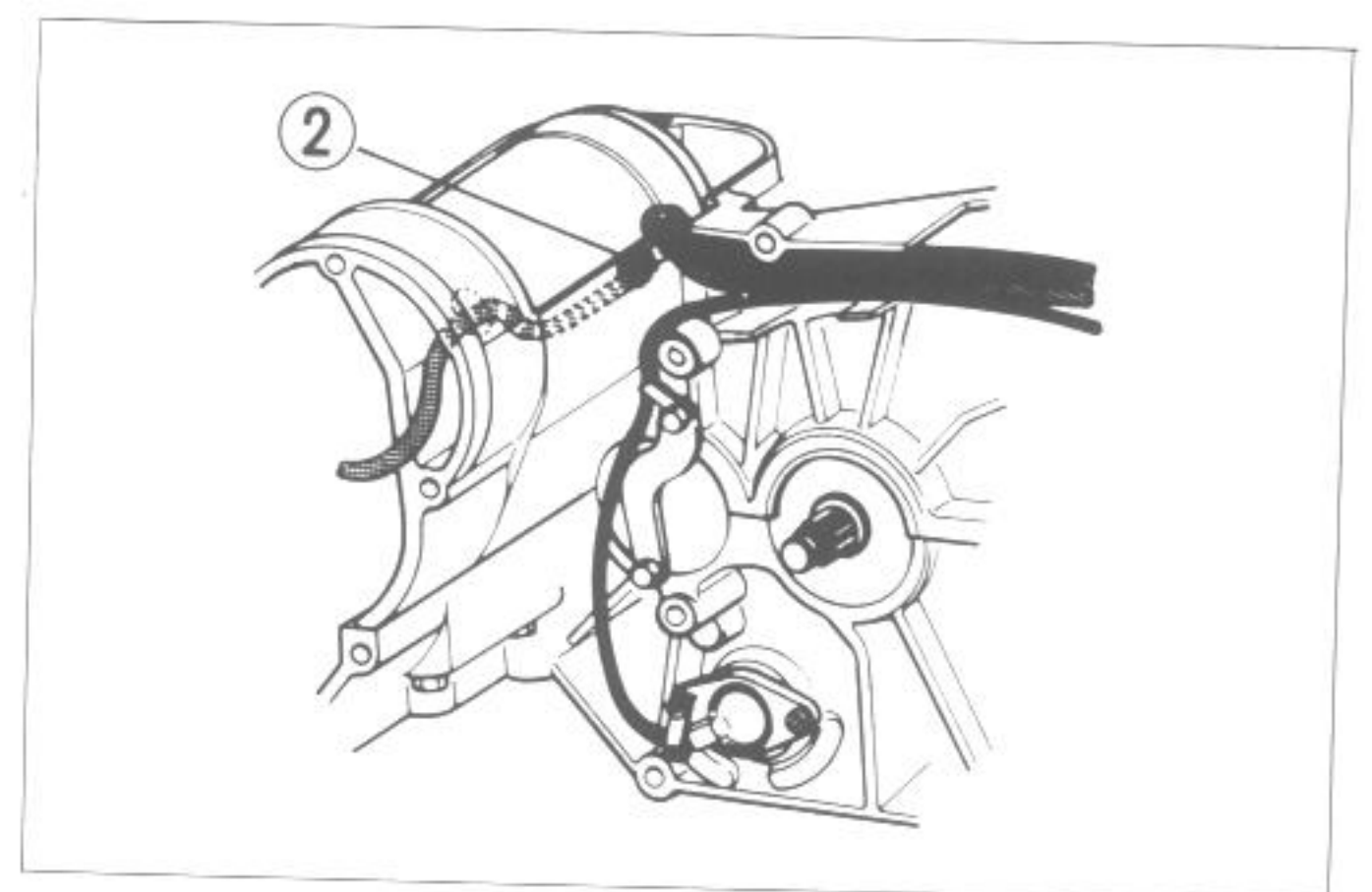
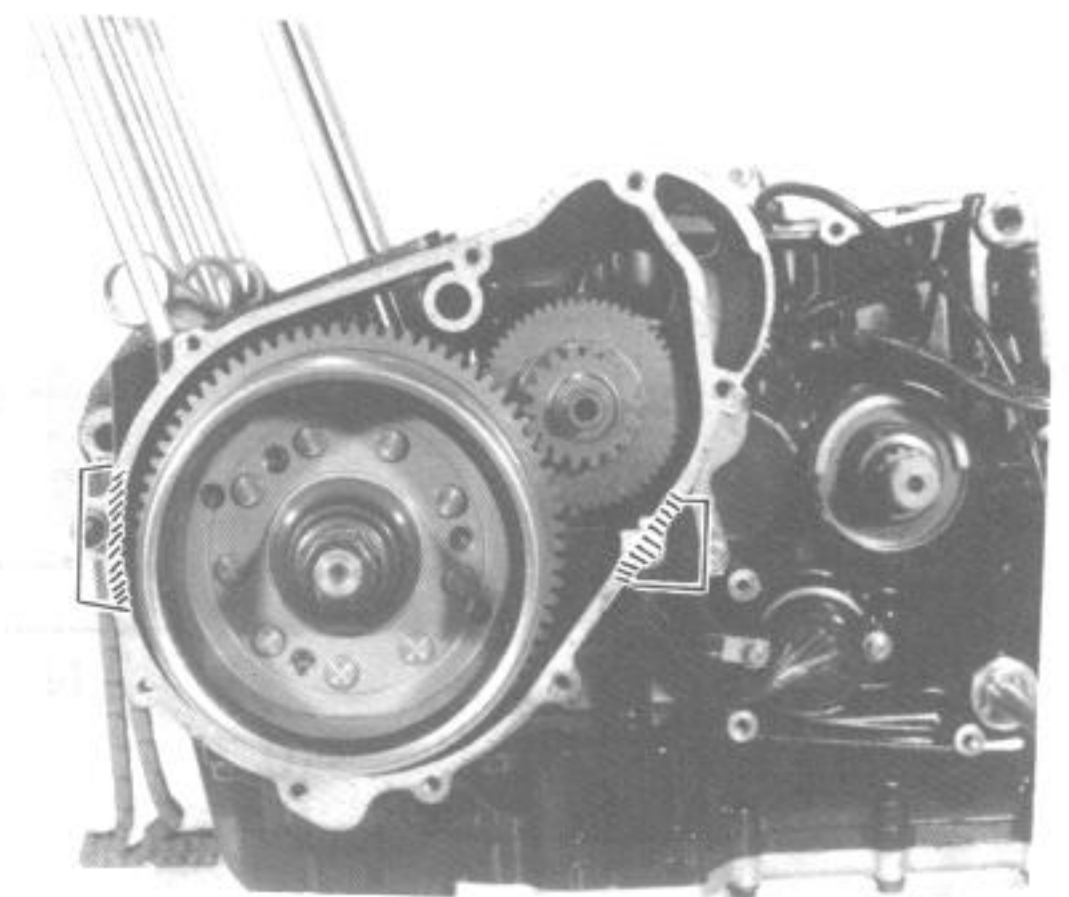
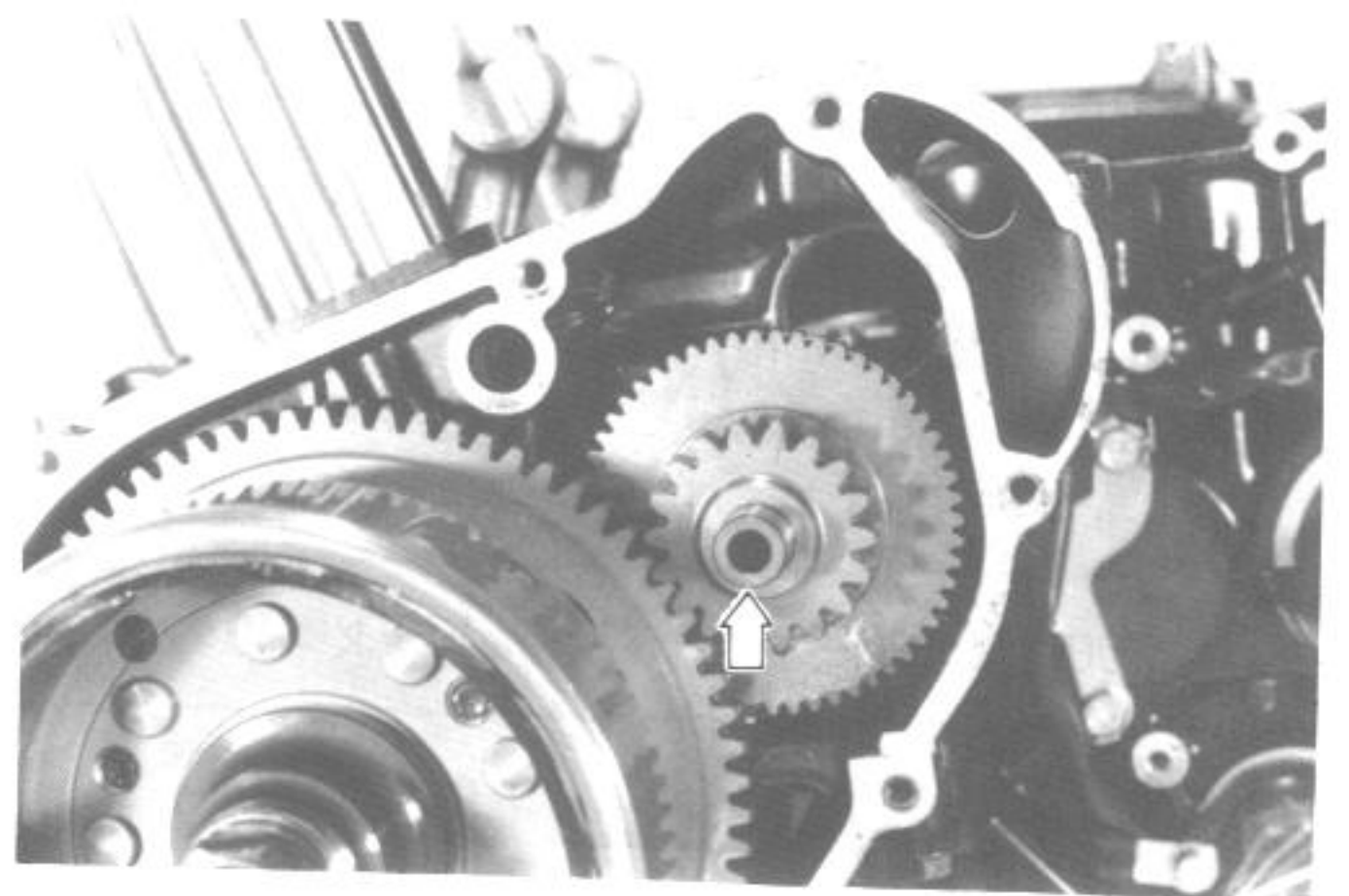
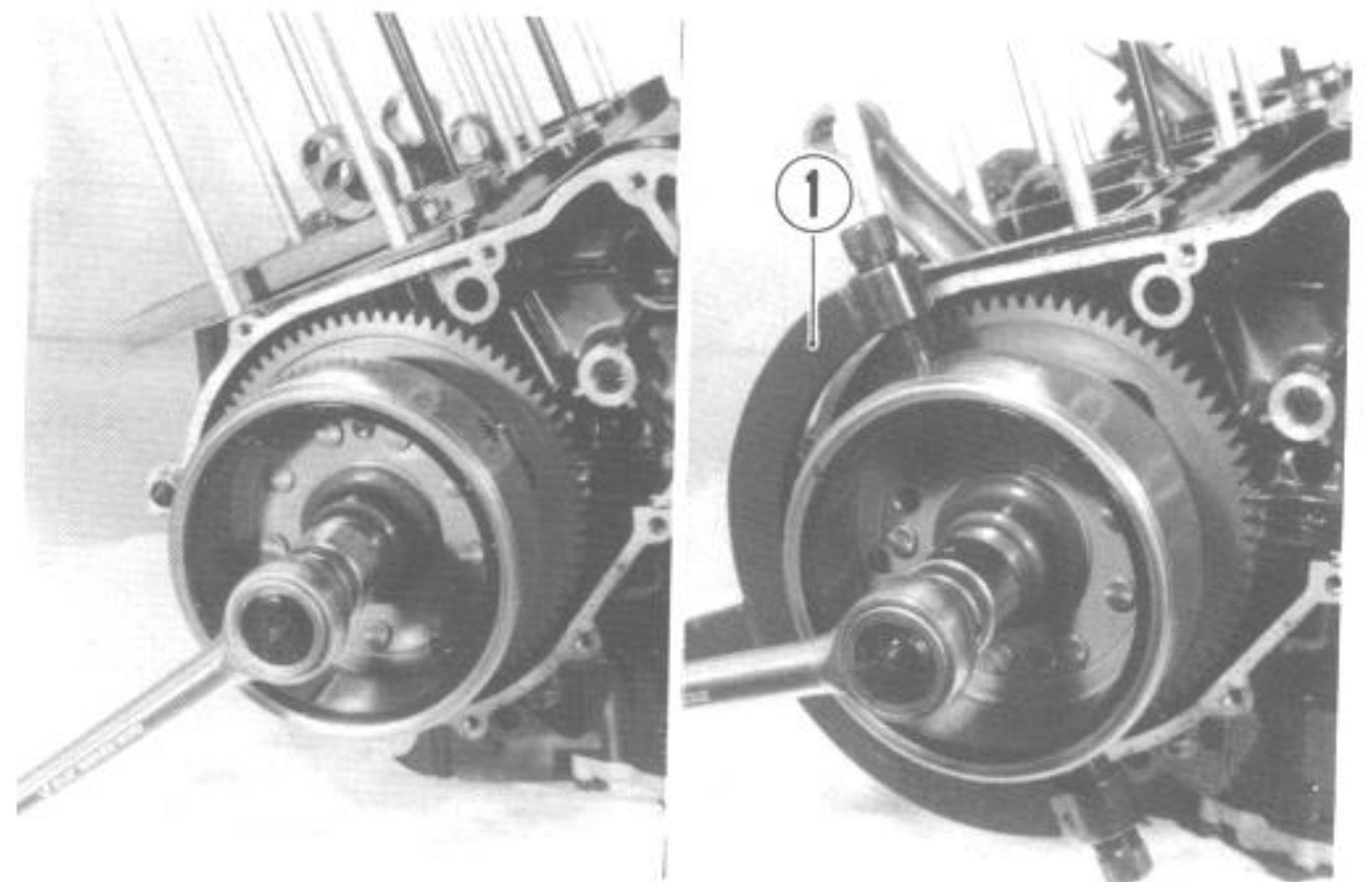

- Mount the starter motor and route the lead wire properly.

99000-32050	Thread lock "1342"
-------------	--------------------

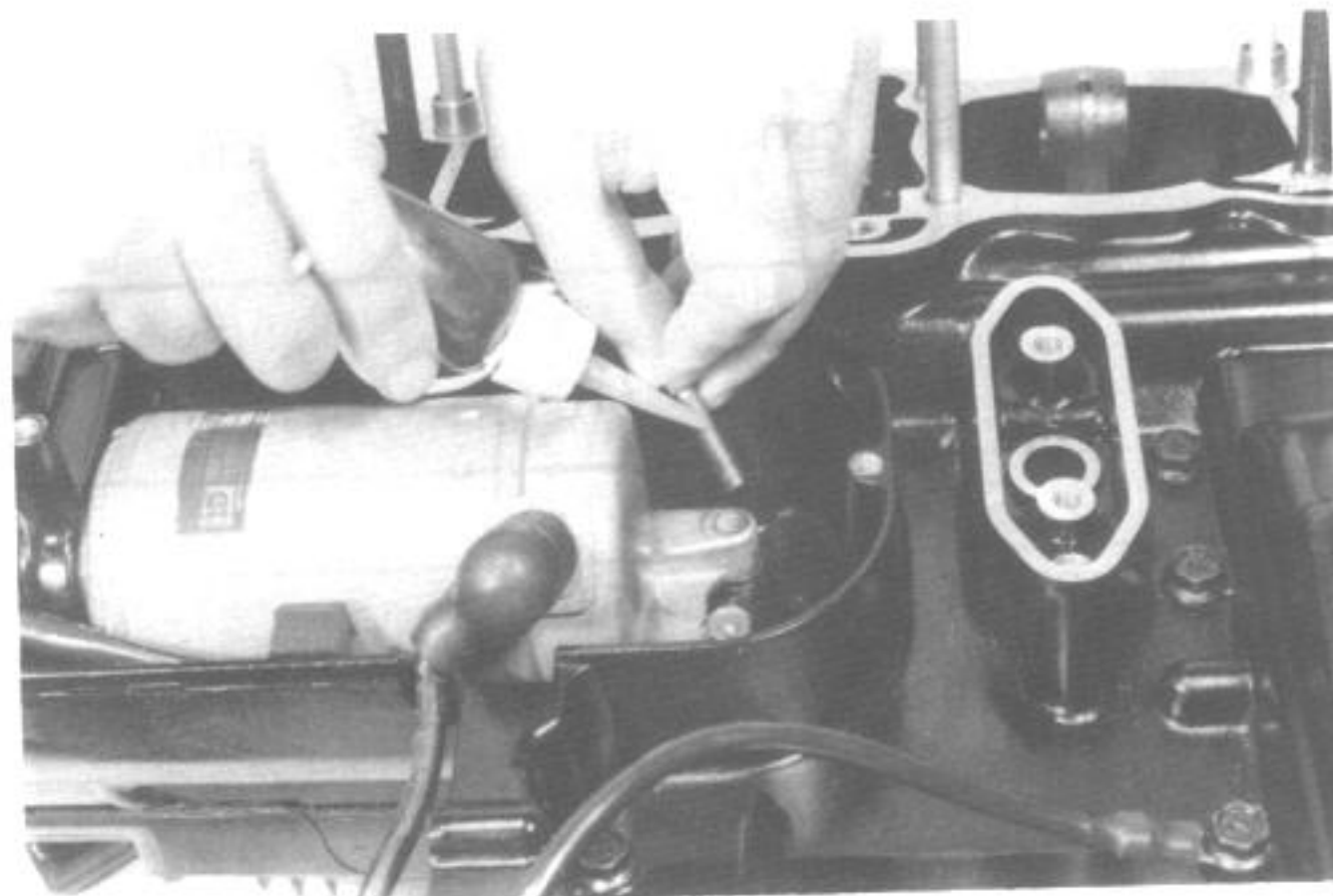

- Install the following items.
 Countershaft bearing retainer screw
3 pcs (overall length 16 mm)
 Drive shaft plate screw
 4 pcs (16 mm)
 Oil gallery plate screw
 3 pcs (16 mm)

99000-32050	Thread lock "1342"
-------------	--------------------

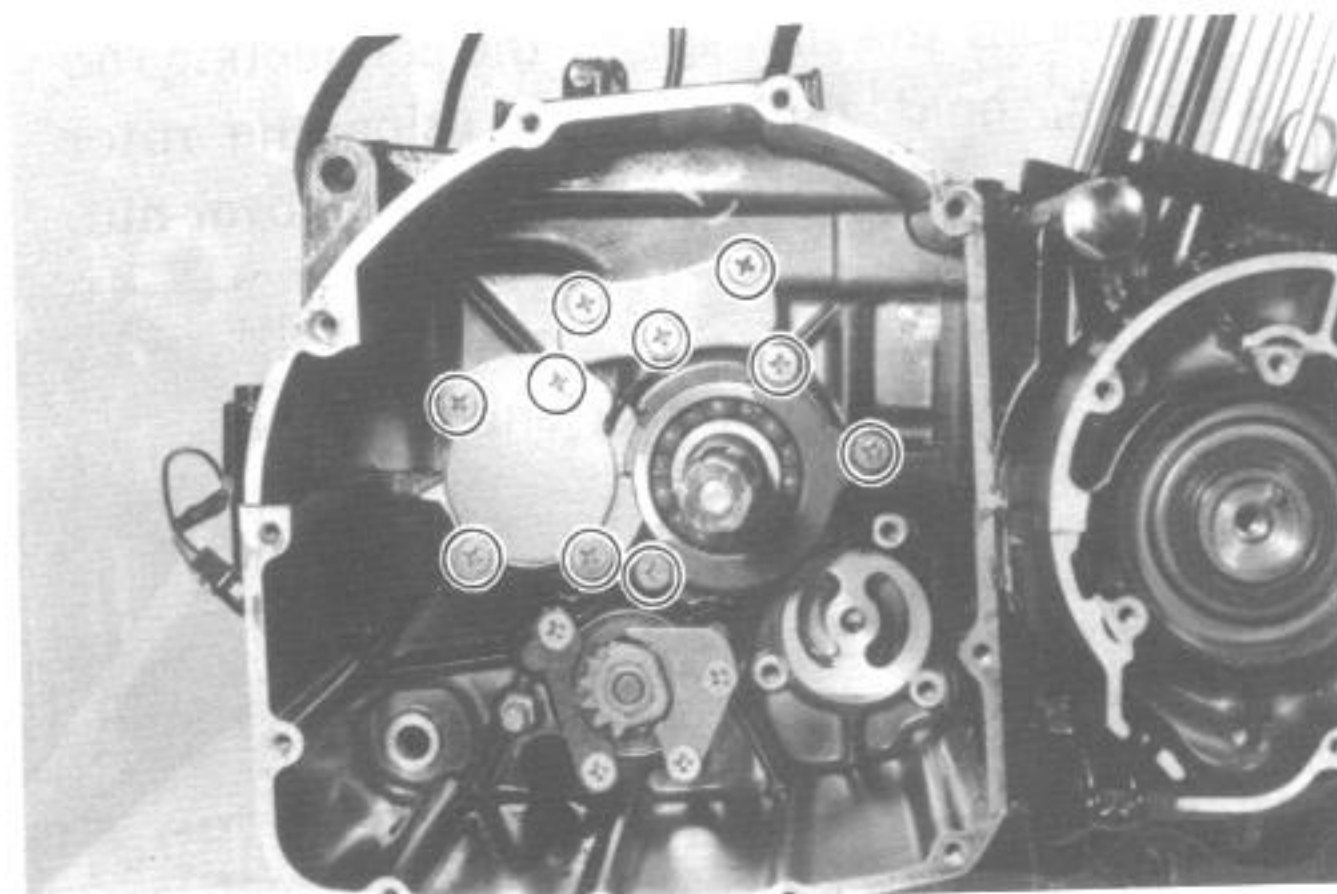

- Install the oil pump assembly insuring that a new O-ring ① is installed.
- Apply a small quantity of THREAD LOCK "1342" to the bolts.

99000-32050	Thread lock "1342"
-------------	--------------------

Tightening torque	7 – 9 N·m (0.7 – 0.9 kg·m)
-------------------	-------------------------------

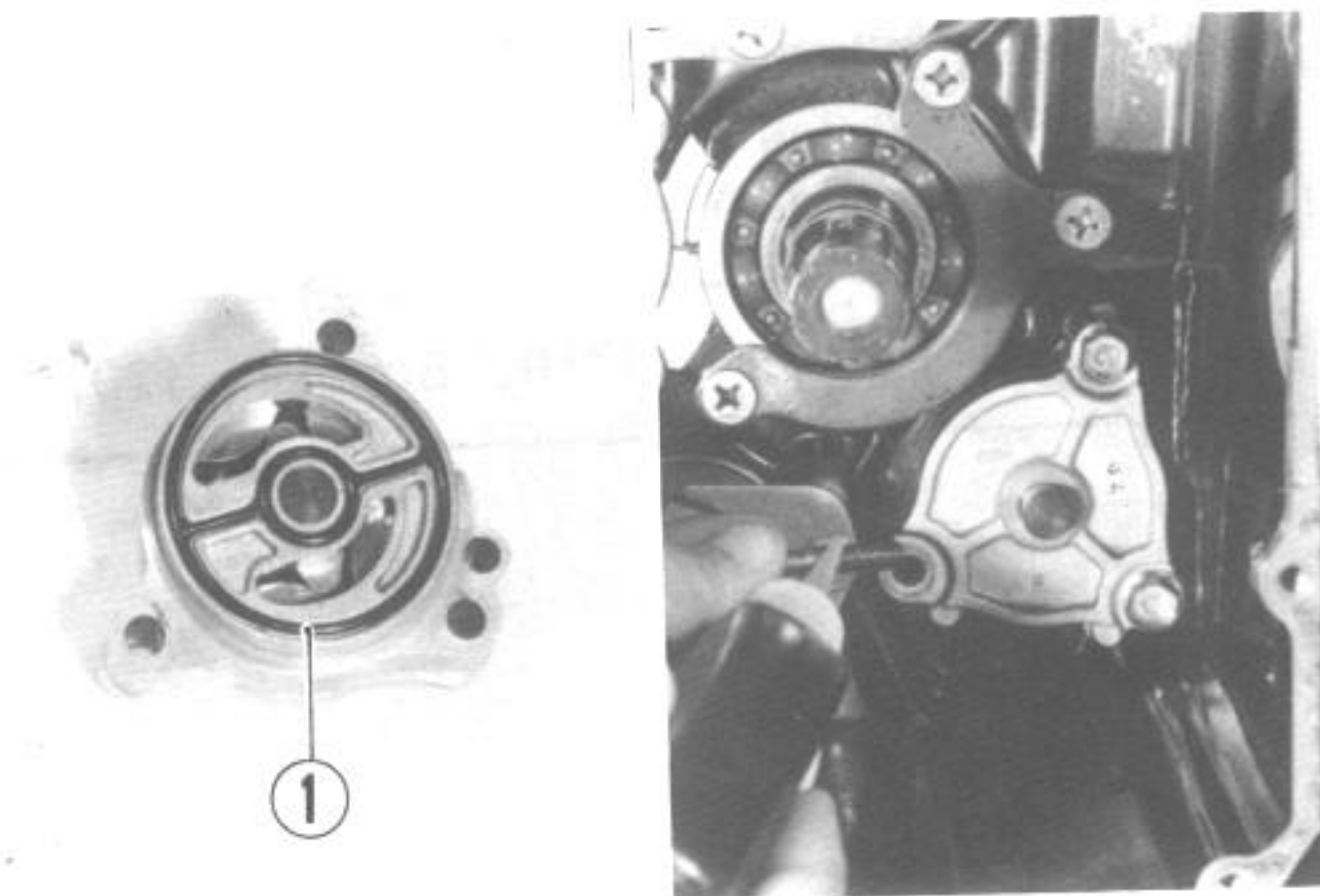

- Install the washer and align the dents ② of the oil pump driven gear with drive pin, and fit circlip by using snapping pliers.

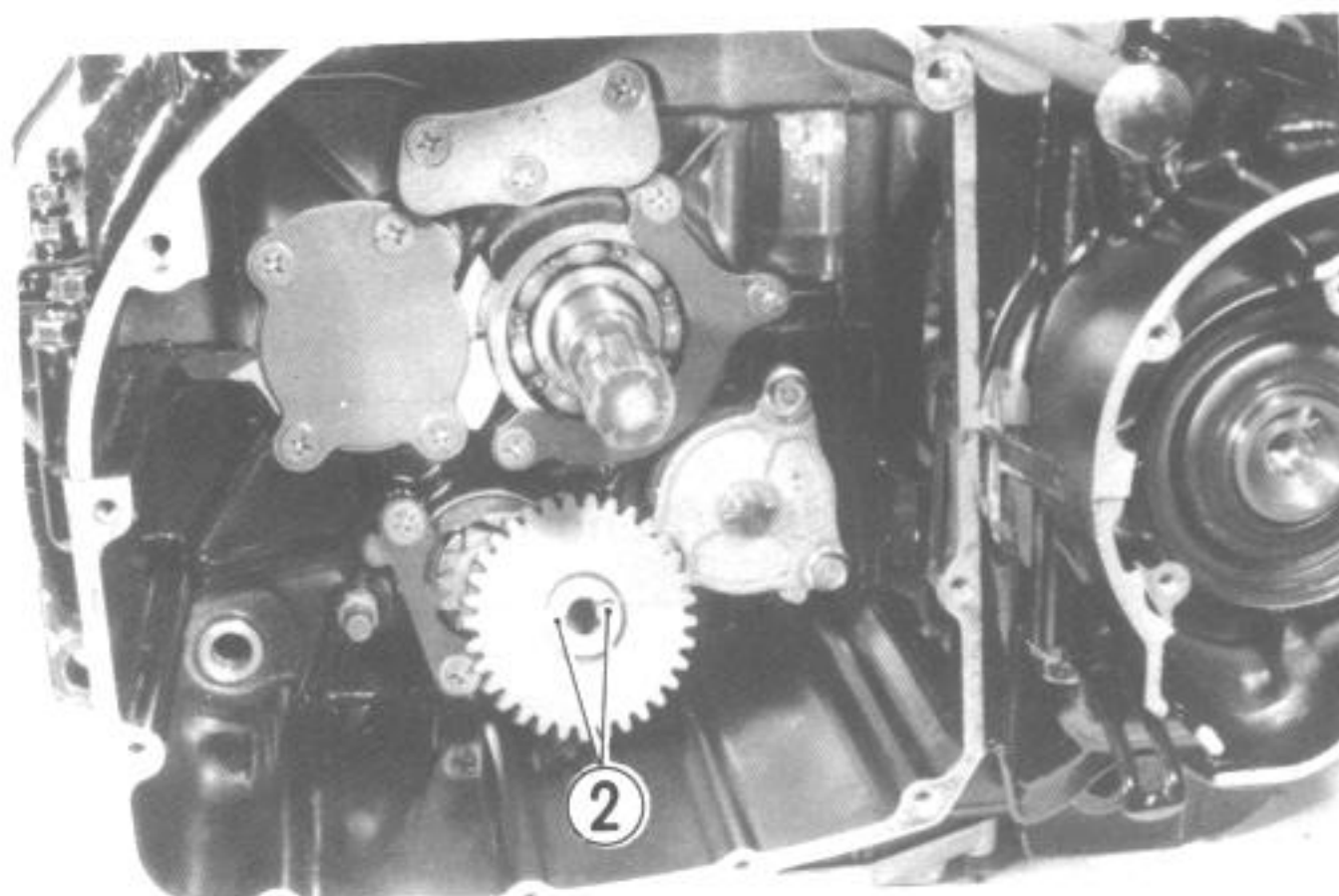

- Install the gearshift shaft, with the center of the gear on shaft side aligned the center of gearshift cam driven gear.
- Fix washer and clip to the gearshift shaft.

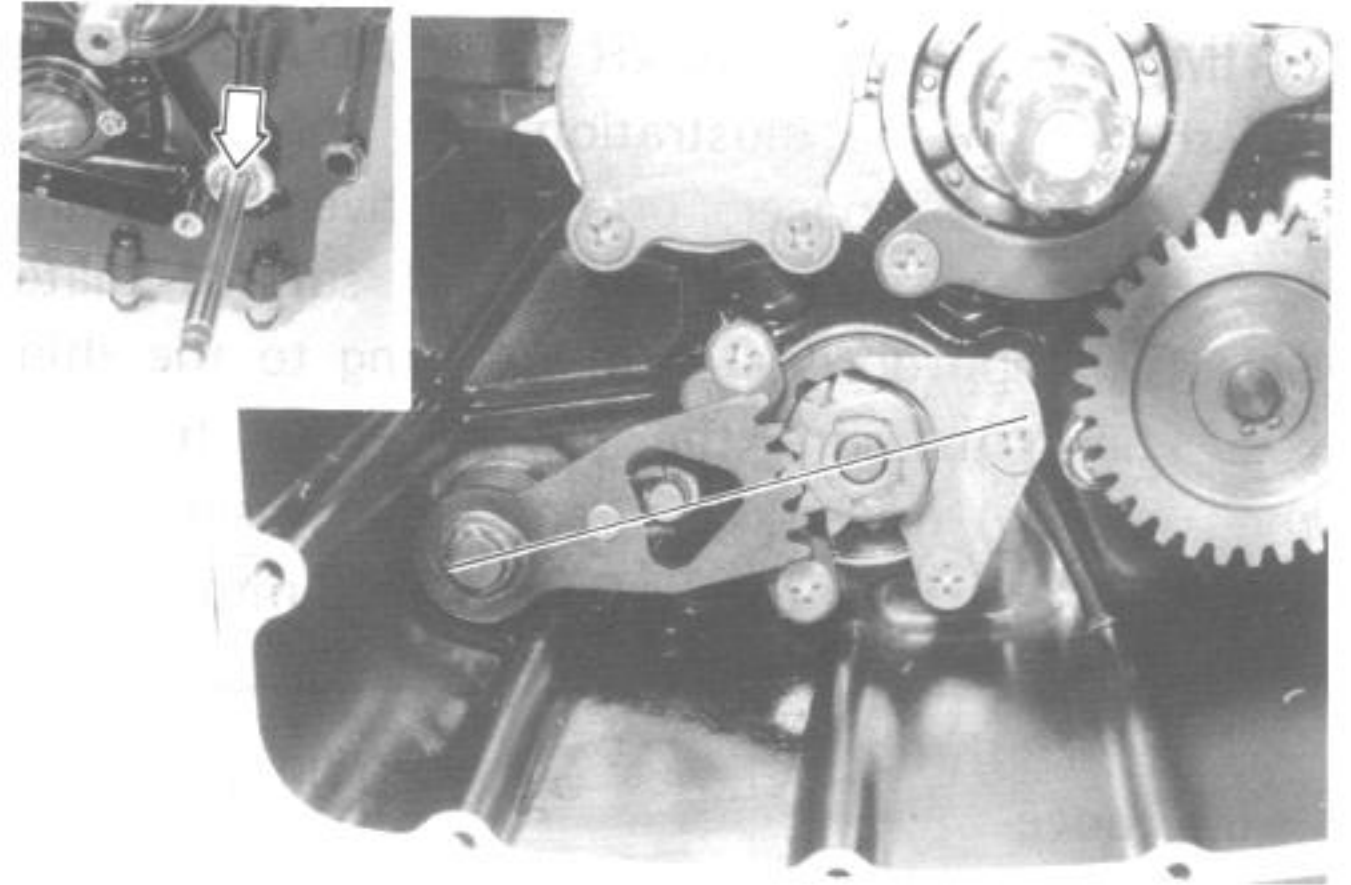

- Install the washer ① and oil pump drive gear spacer ②.
- Apply engine oil to the oil pump drive gear bearing ③ and fix the drive gear ④ to face the protrusion ⑤ outside. This protrusion should be aligned with the notches ⑥ of the primary driven gear.

NOTE:

Check that the rubber damper plug is in position behind the primary driven gear assembly.

- Assemble the primary driven gear ⑦ and apply engine oil to the needle bearing ⑧ and its spacer with oil groove facing inside.
- Install the shim ⑨ and thrust washer ⑩.

NOTE:

Thrust washer must be installed with the oil groove side facing in.

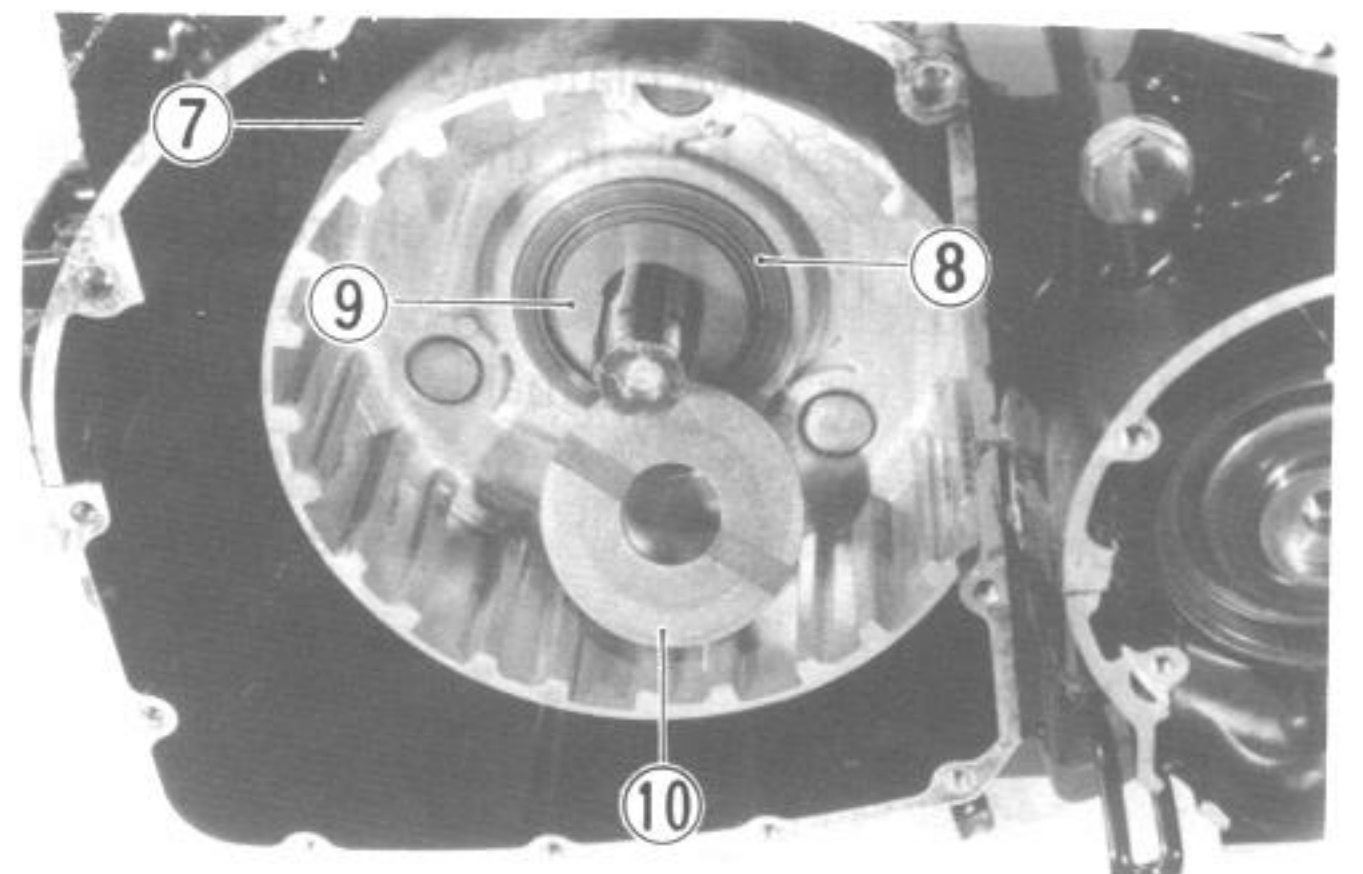
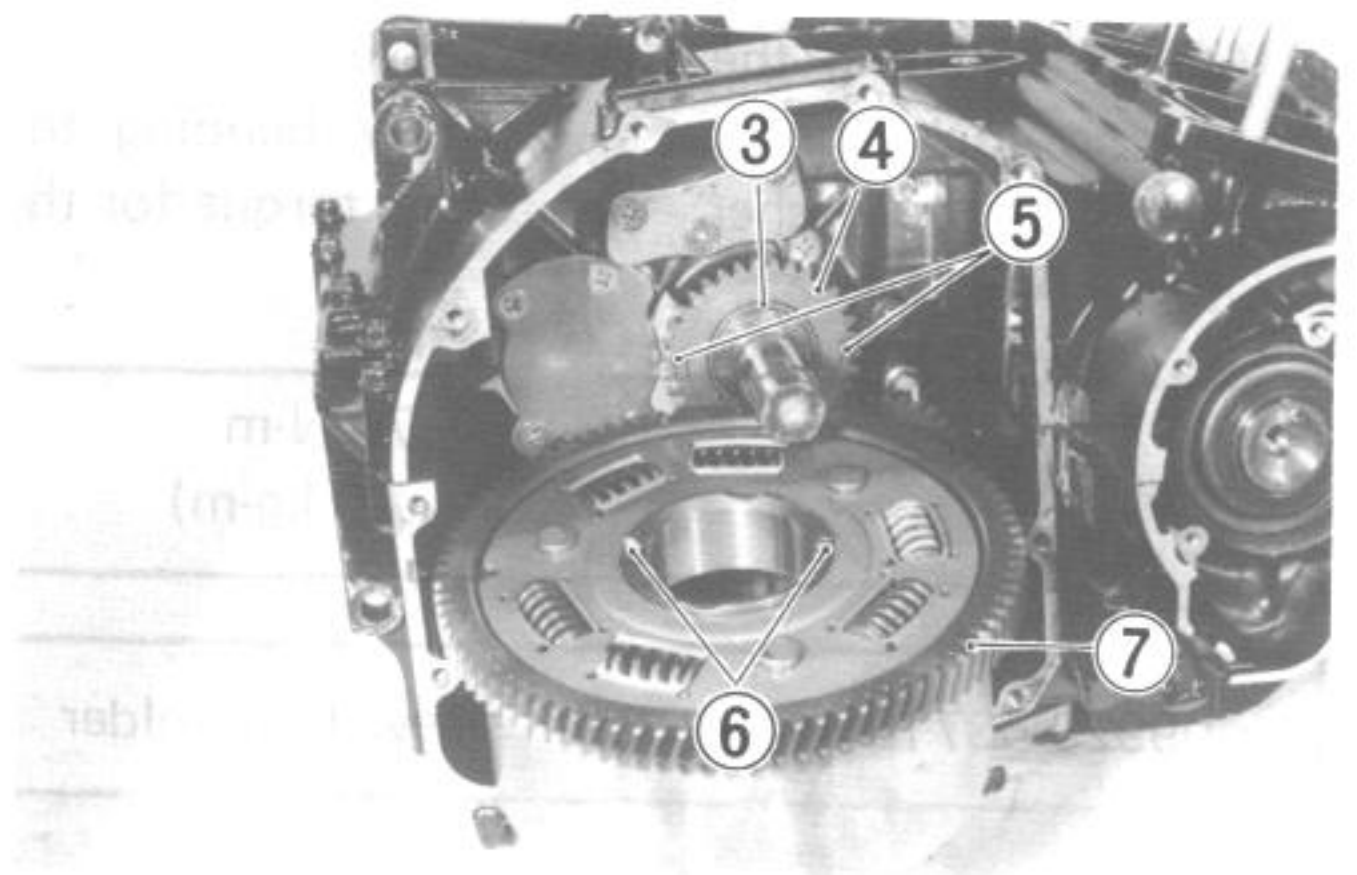
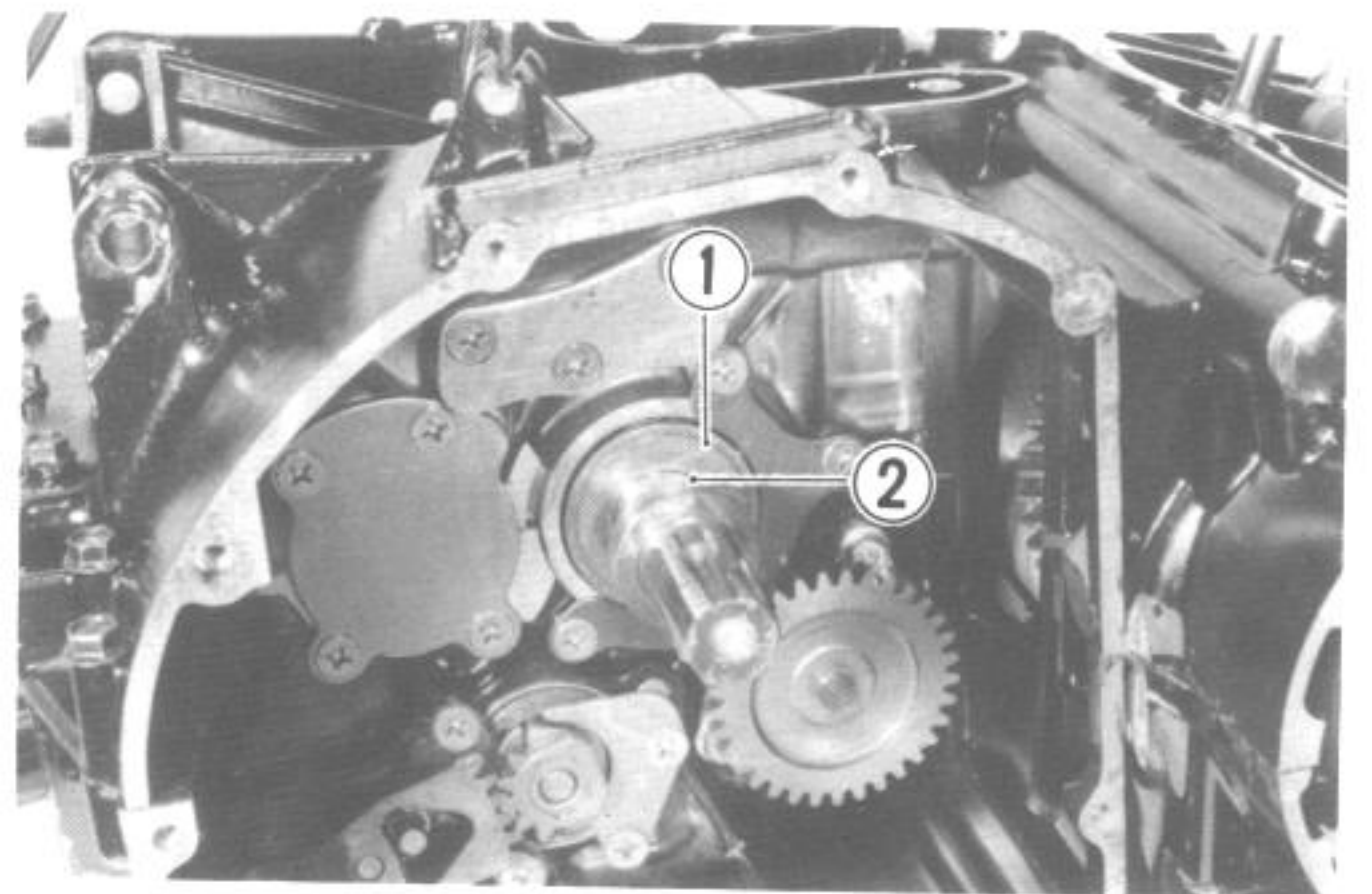

PRIMARY DRIVEN GEAR SHIM ADJUSTMENT

As shown in the illustration, put the oil pump drive gear, its spacer, primary driven gear, and its spacer and washer on a flat surface plate. Select an appropriate shim referring to the shim size chart, measure the clearance **B** between the primary driven gear and the washer, and check that the clearance is 0.03 – 0.08 mm.

Standard thrust clearance	0.03 – 0.08 mm
---------------------------	----------------

When any one of the above parts ① – ④ is replaced, be sure to adjust and check the shim to confirm that the clearance is normal.

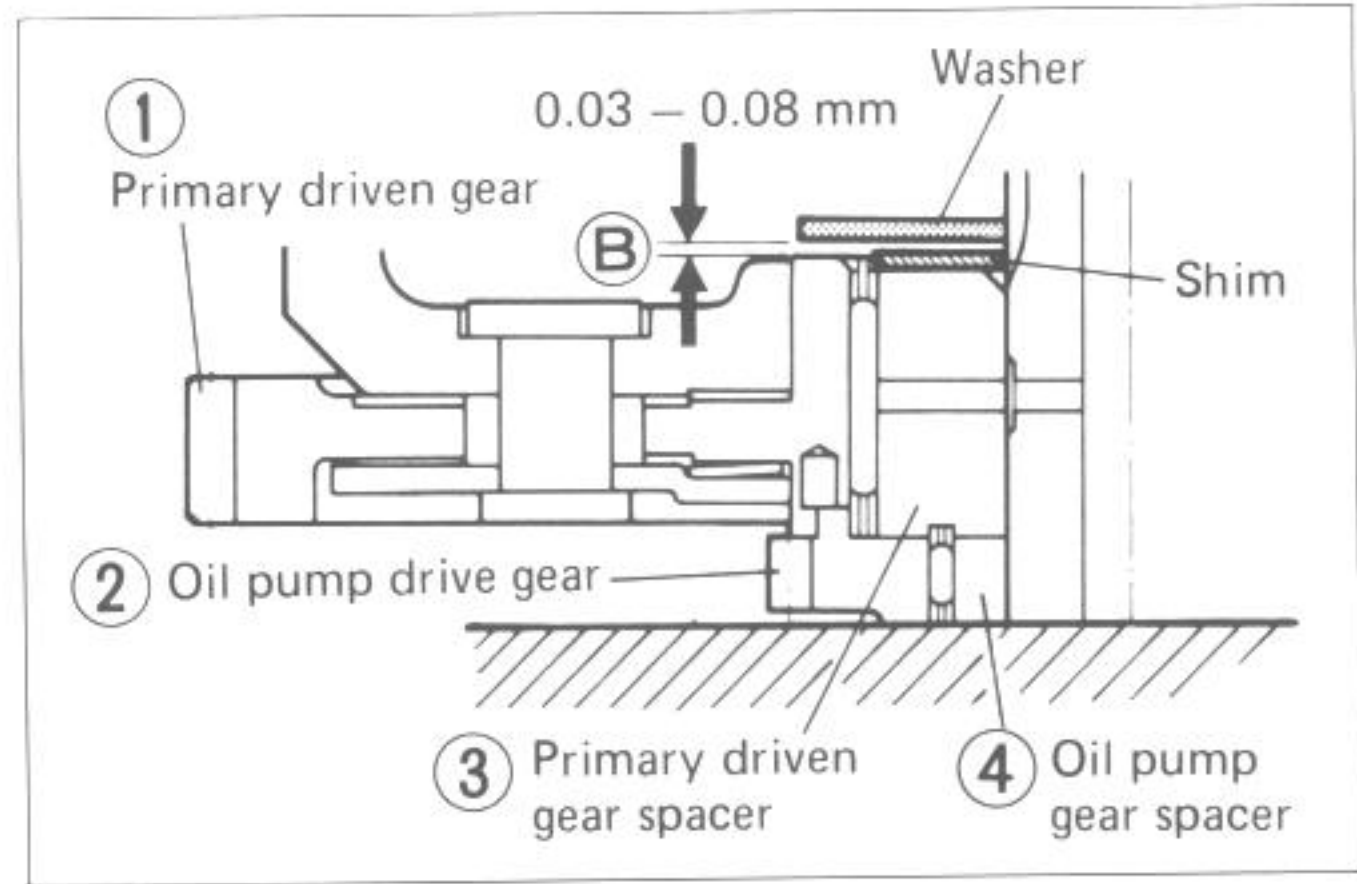

Shim size chart

Part No.	Thickness
21262-09300	1.05 mm
21263-09300	1.10 mm
21264-09300	1.15 mm
21265-09300	1.20 mm

- After tightening the clutch sleeve hub nut, be sure to lock the nut by firmly bending the tongue of the washer. Tightening torque for the nut is specified.

Tightening torque	50 – 70 N·m (5.0 – 7.0 kg-m)
-------------------	---------------------------------

09920-53710	Clutch sleeve hub holder
-------------	--------------------------

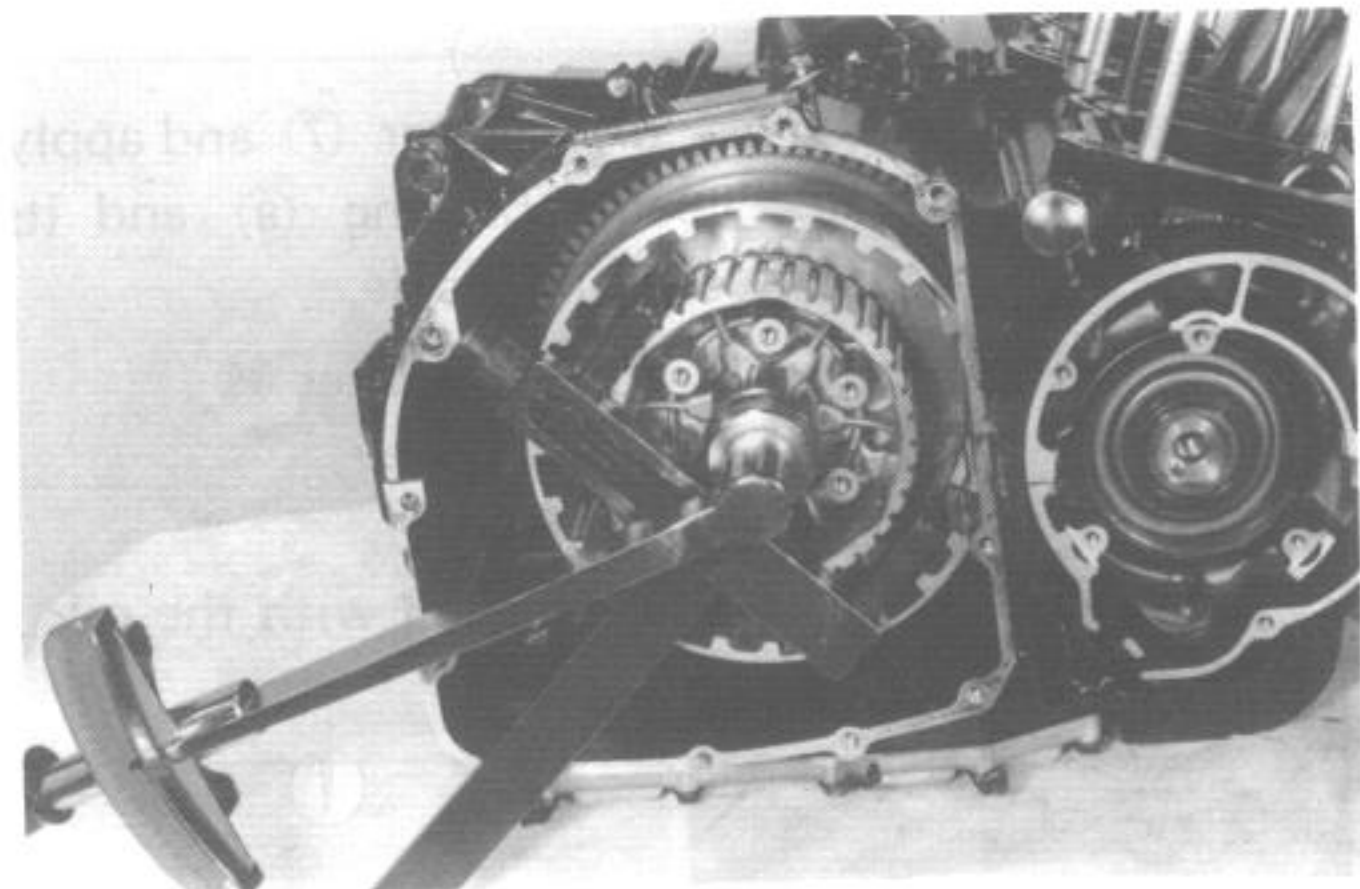

- Insert the clutch drive plate and driven plate one by one into sleeve hub in the prescribed order, cork plate first. Insert clutch release rack, bearing and thrust washer into pressure plate and lock it by E-ring, making sure that the thrust washer is between the bearing and the pressure plate, then fit pressure plate into sleeve hub.

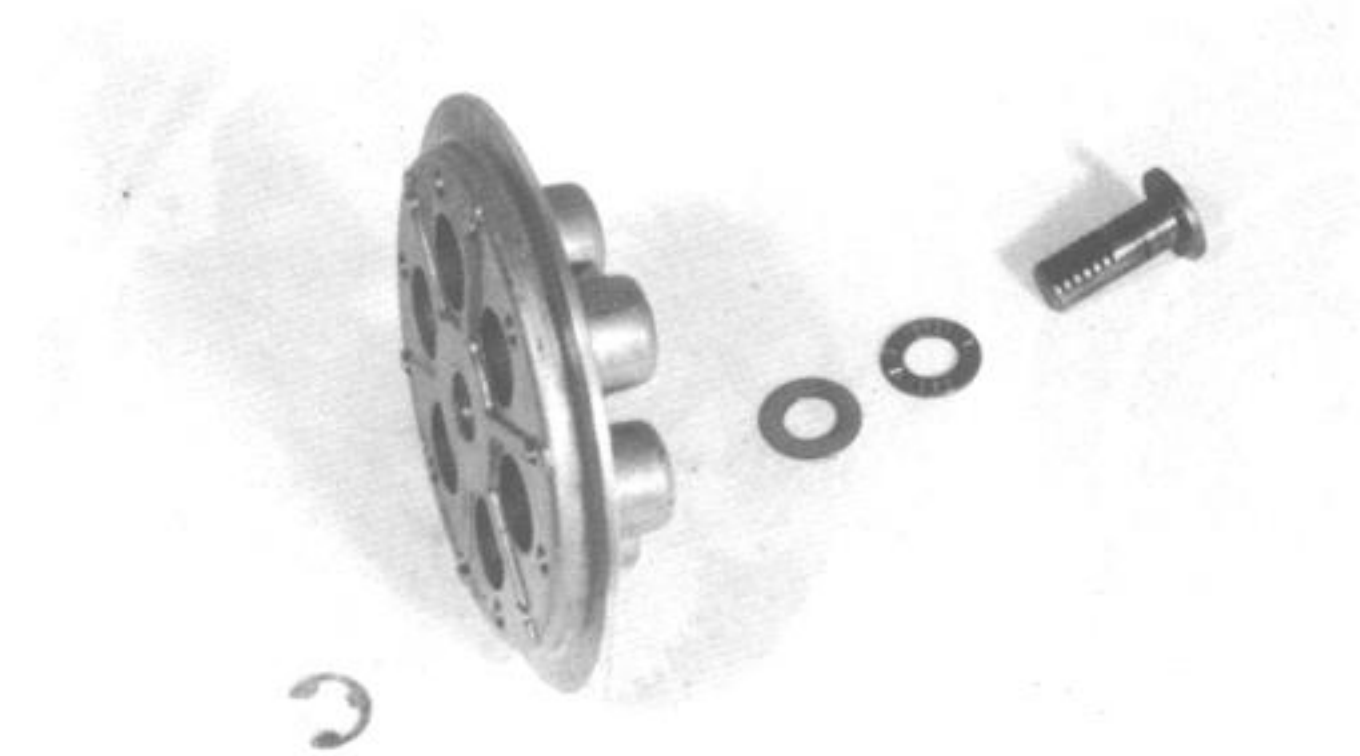

- Tighten the clutch spring bolts in the order shown in the photo.

NOTE:
Tighten the clutch spring set bolts in the manner indicated, tightening them by degrees until they attain a uniform tightness.

Tightening torque	11 – 13 N·m (1.1 – 1.3 kg-m)
-------------------	---------------------------------

- Coat SUZUKI Bond No. 1207B lightly to the portion around mating surface between crank-cases as shown.

99000-31140	SUZUKI Bond No. 1207B
-------------	-----------------------

- Replace the clutch cover gasket with new one to prevent oil leakage.

- Engage the teeth of clutch release rack with those of pinion gear at the clutch cover side and replace clutch cover. Make sure that the rack and pinion gear engage positively. To install cover, tap lightly with plastic hammer.

- Install the positioning pins, a new gasket and clutch cover, and tighten cover bolts securely.

NOTE:
Fit up the gasket to the clutch cover bolt (A) correctly as shown in Fig.

CAUTION:
Use only new gasket to prevent oil leakage.

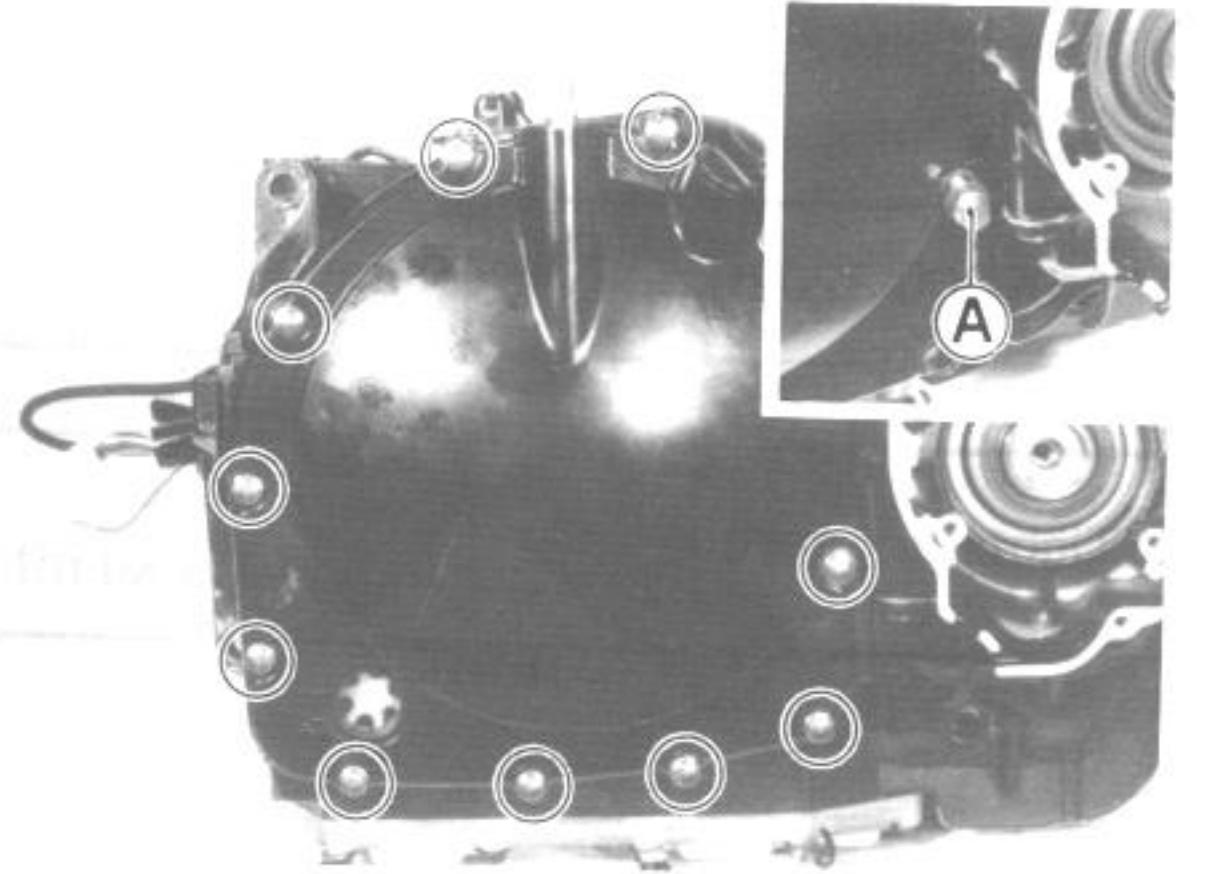
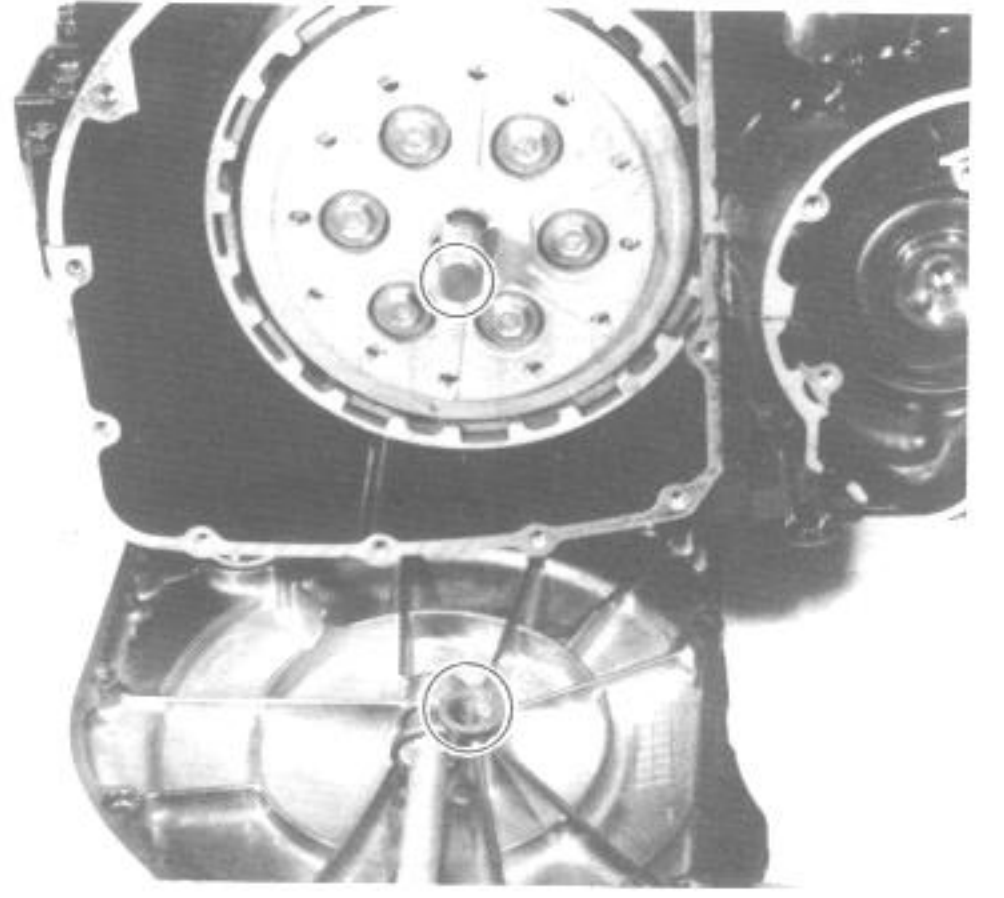
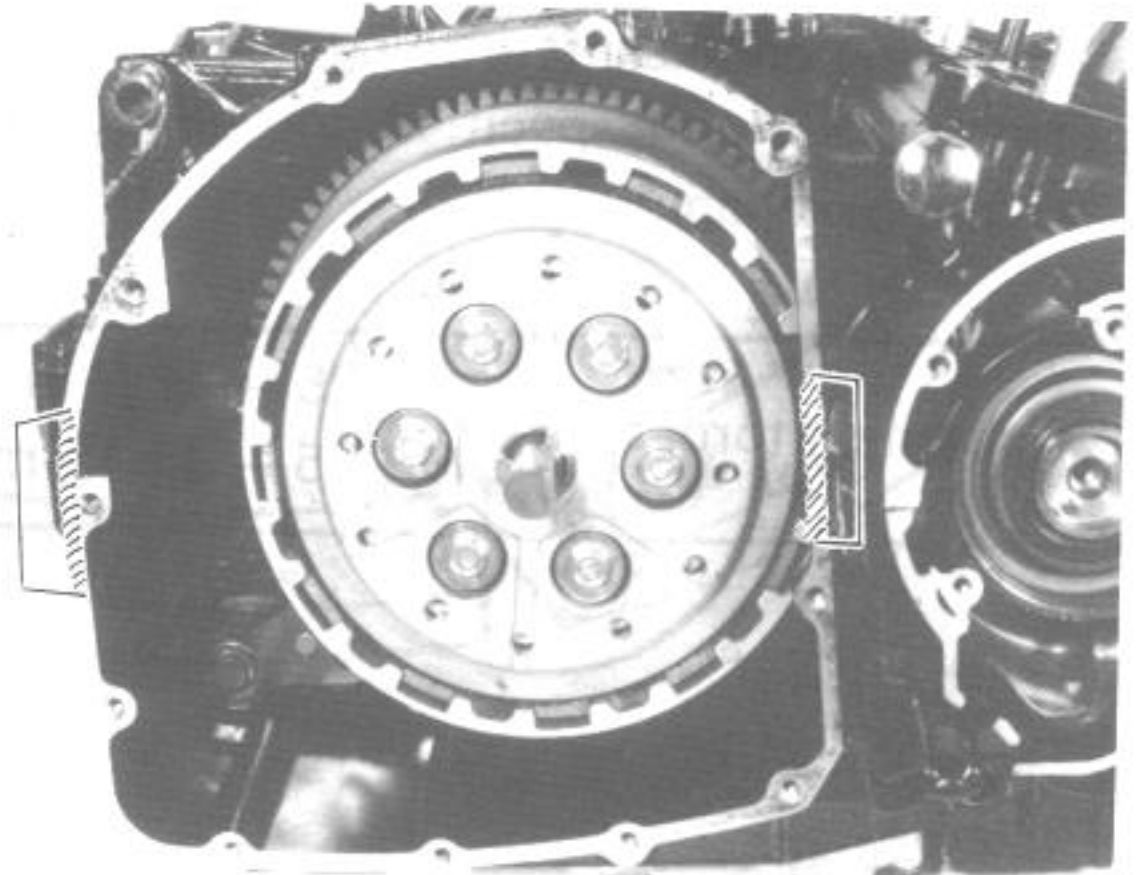
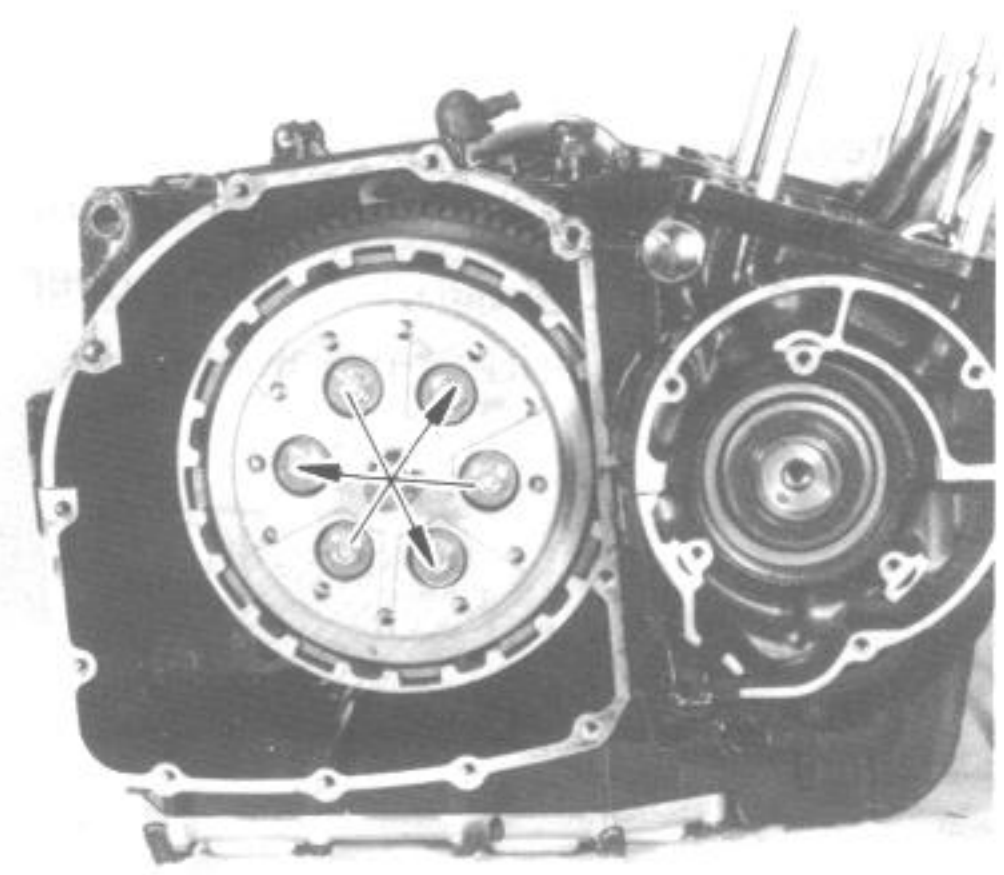

- Install the signal generator stator with three screws.
- Make sure to fit the slot ① on the back surface of the signal generator rotor over the locating pin ② at the end of crankshaft.

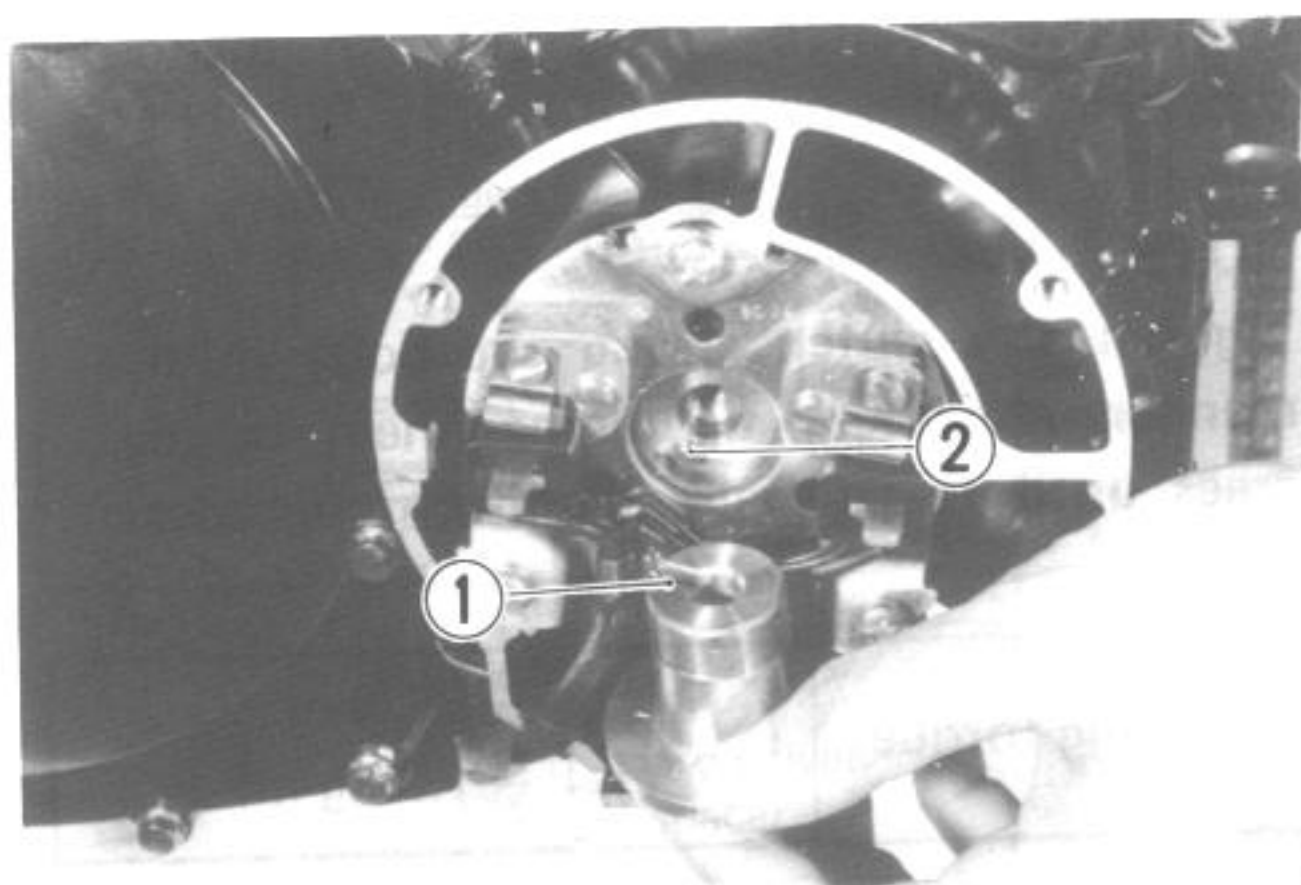

- Hold the crankshaft turning nut and tighten the rotor bolt with specified torque by using the 6 mm hexagon wrench.

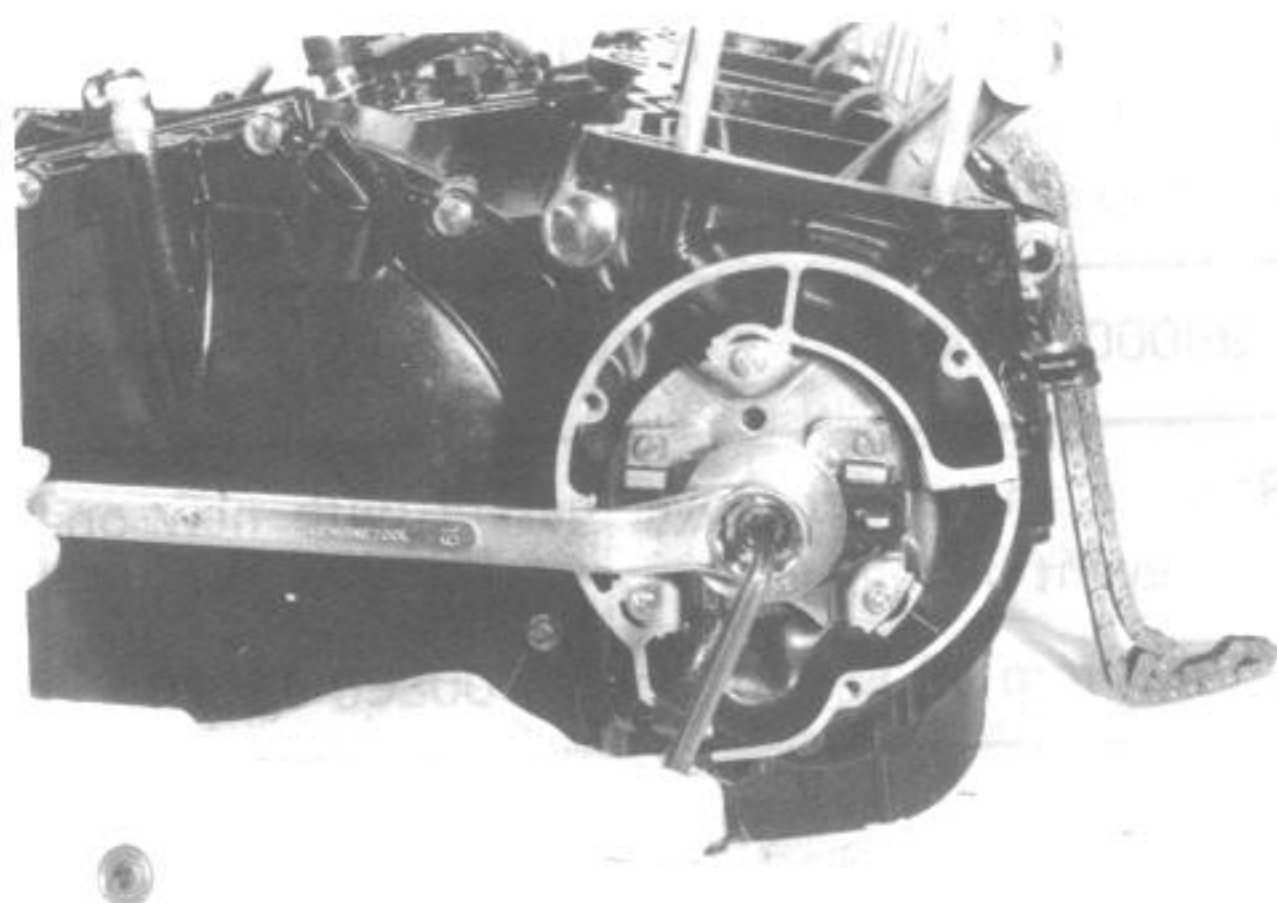

Tightening torque	25 – 35 N·m (2.5 – 3.5 kg-m)
-------------------	---------------------------------

- Route the signal generator lead wire as shown in the figure.

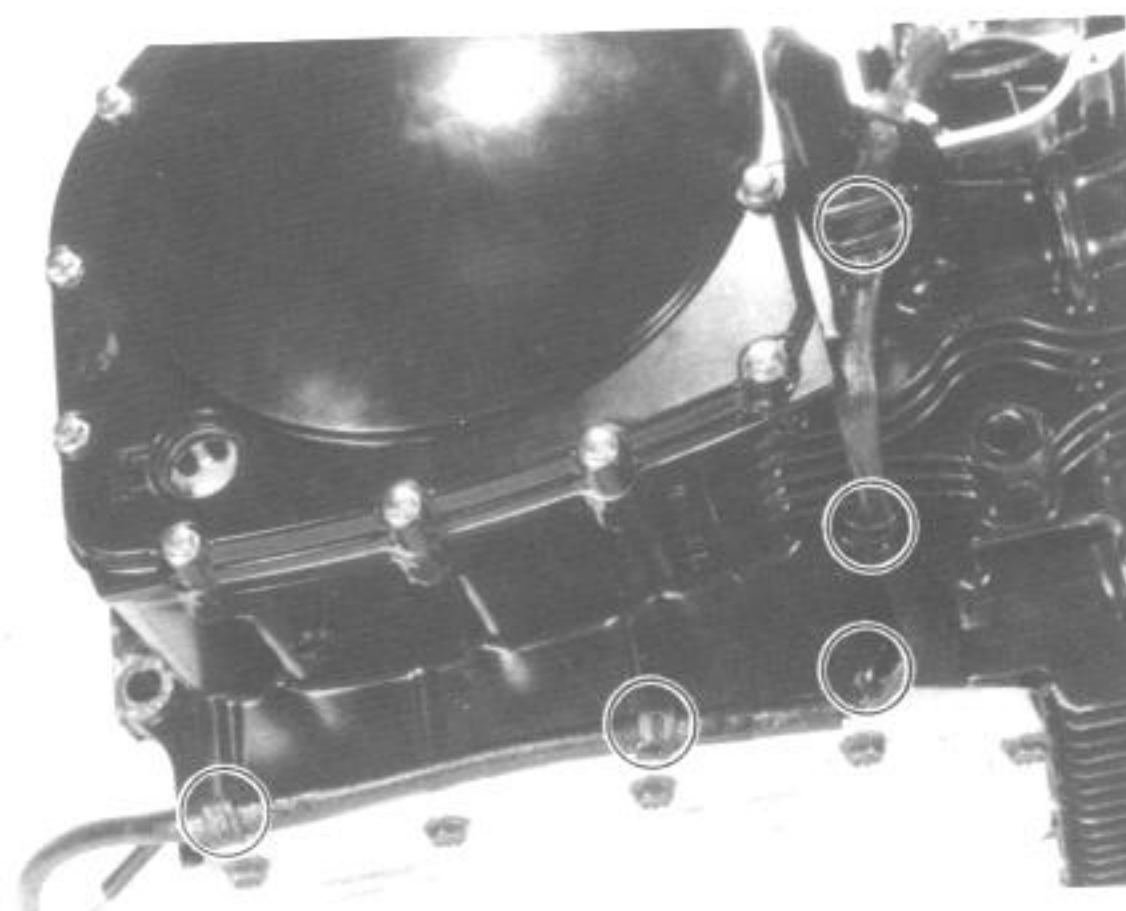

- Install the cam chain guide and tighten bolt with apply thread lock super "1333B".

99000-32020	Thread lock super "1333B"
-------------	---------------------------

Tightening torque	9 – 14 N·m (0.9 – 1.4 kg-m)
-------------------	--------------------------------

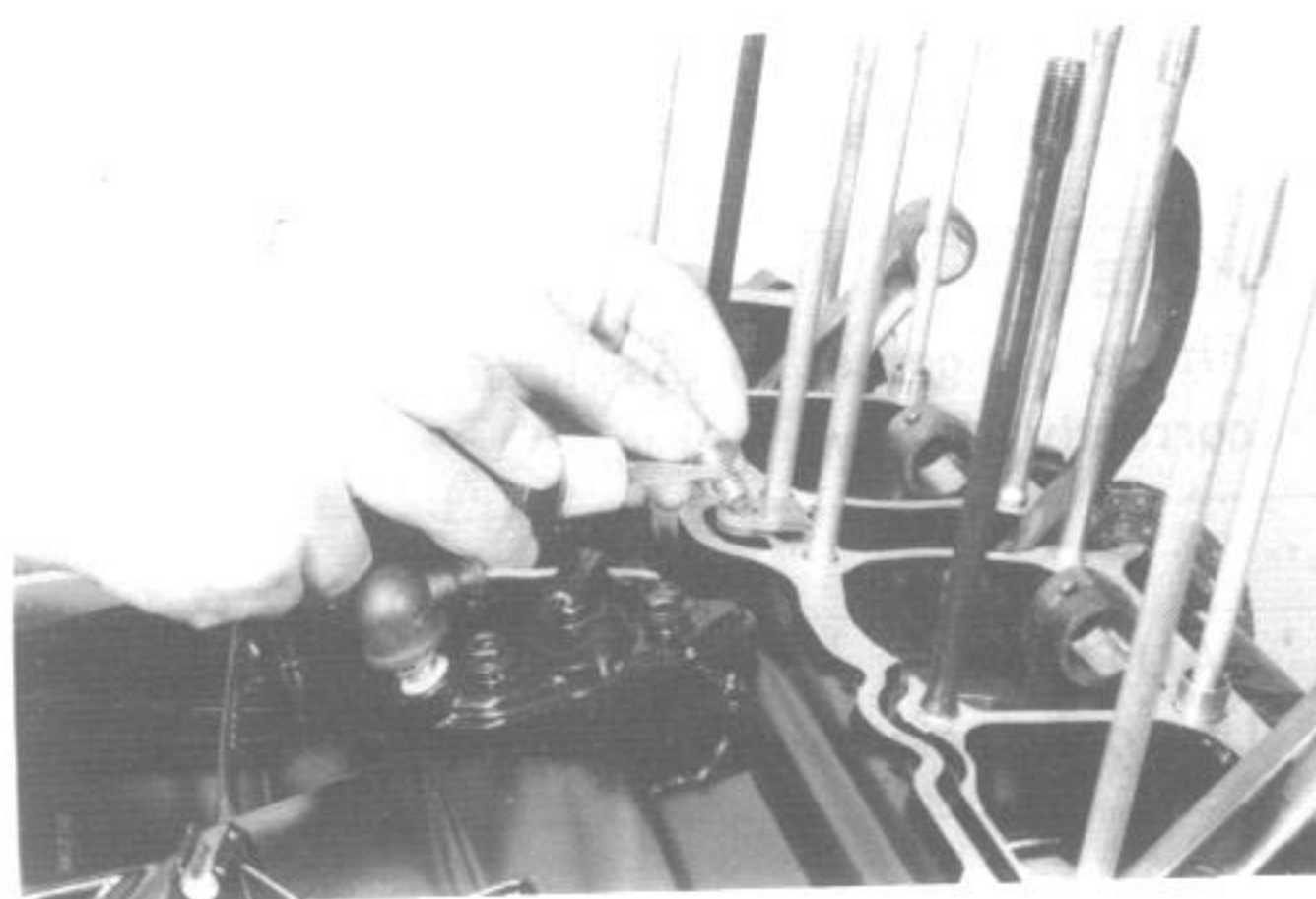

- Mount the piston ring in the order, starting from the bottom of oil ring, 2nd ring and top ring.
- Top ring and 2nd (middle) ring differ in the shape of ring face and material, and the material of top ring is stainless steel whereas that of 2nd ring is not.
The color of 2nd ring appears darker than that of the top one.

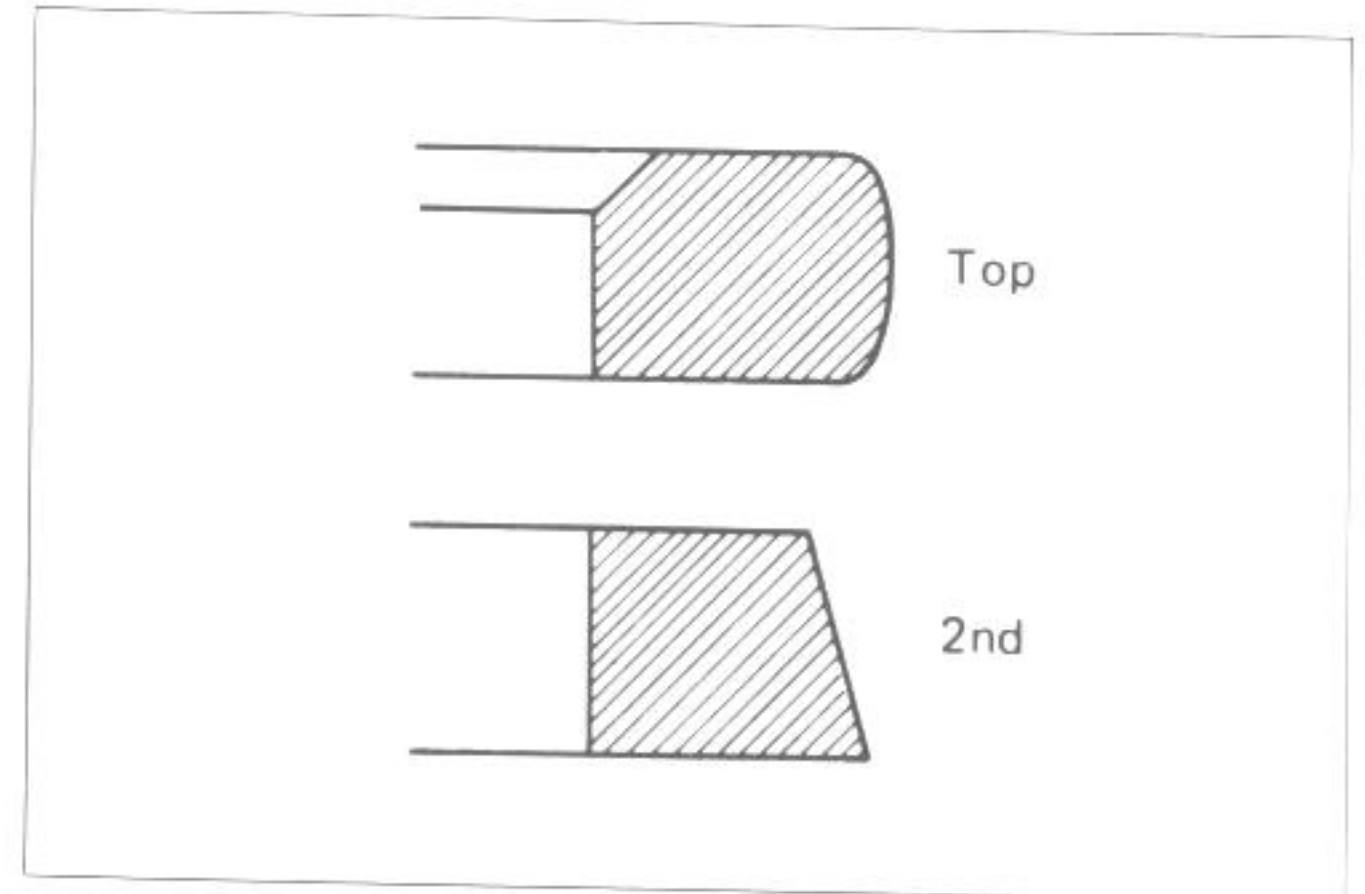

- Top and 2nd (middle) rings have letter "N" marked on the side. Be sure to bring the marked side to top when fitting them to the piston.

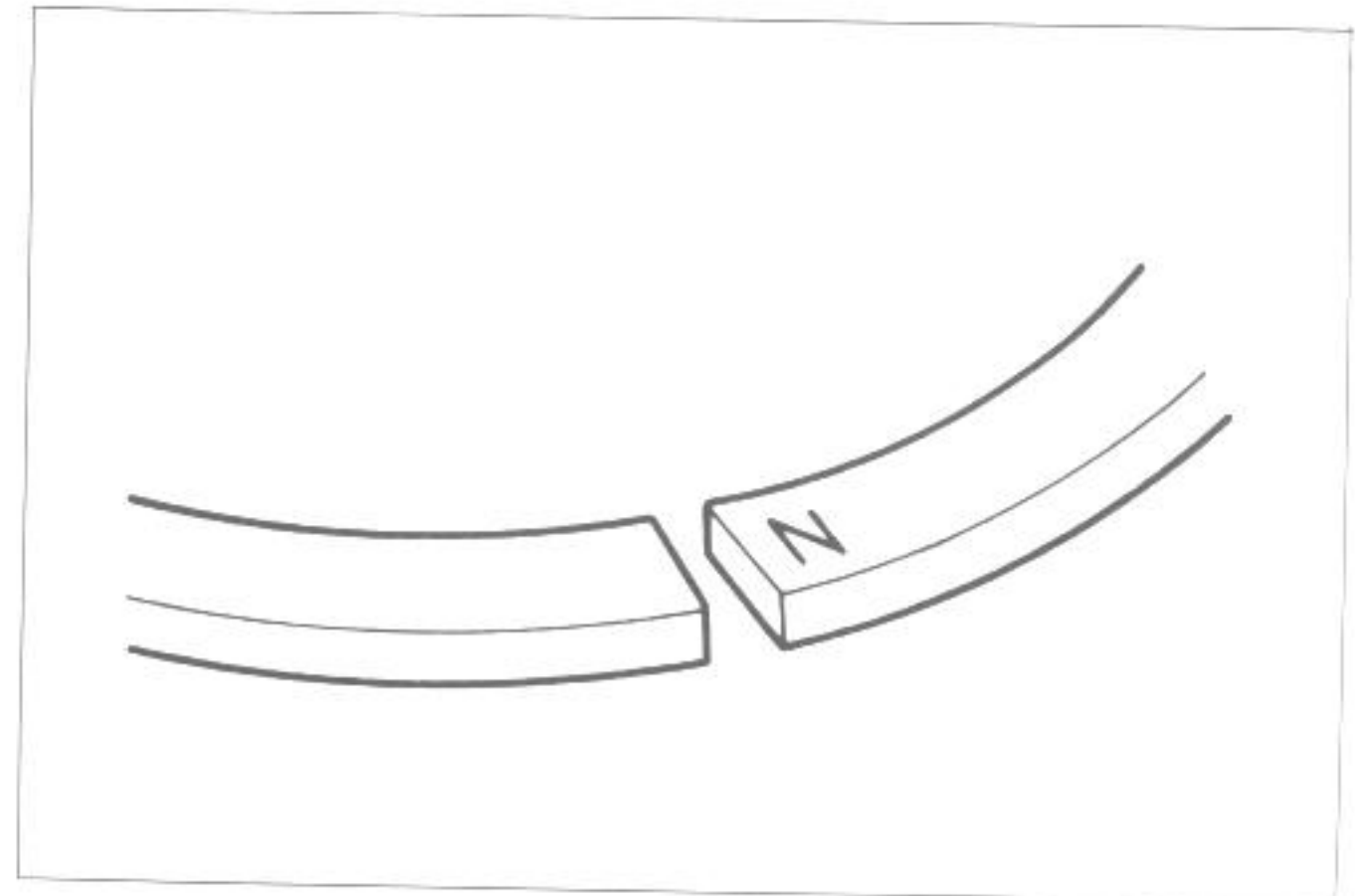

- The first member to go into the ring groove is spacer ①. After placing spacer, fit the two side rails ②. Side designations, top and bottom, are not applied to the spacer and side rails: you can position each either way.

CAUTION:

When mounting the spacer, be careful not to allow its two ends to overlap in the groove.

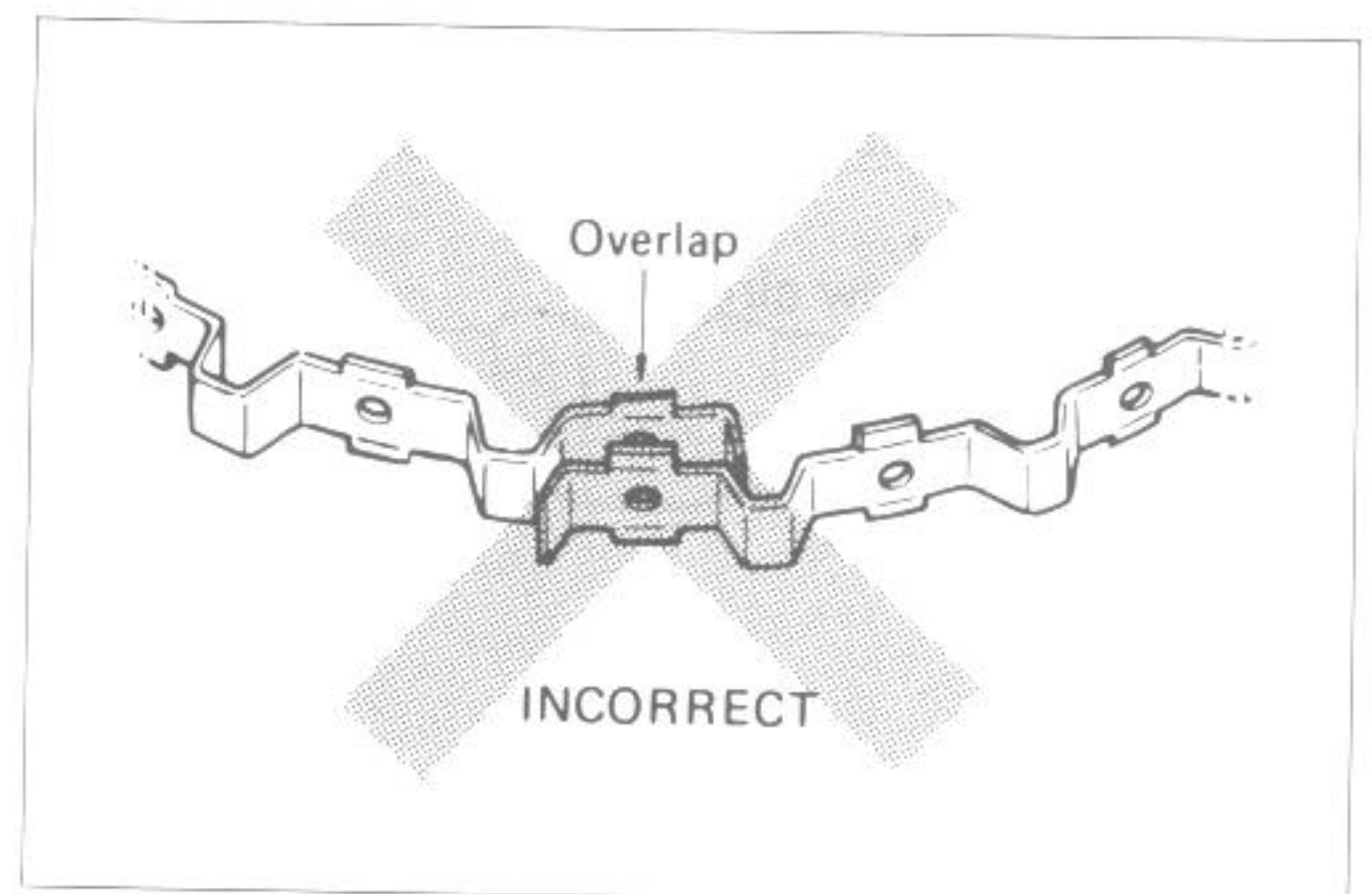
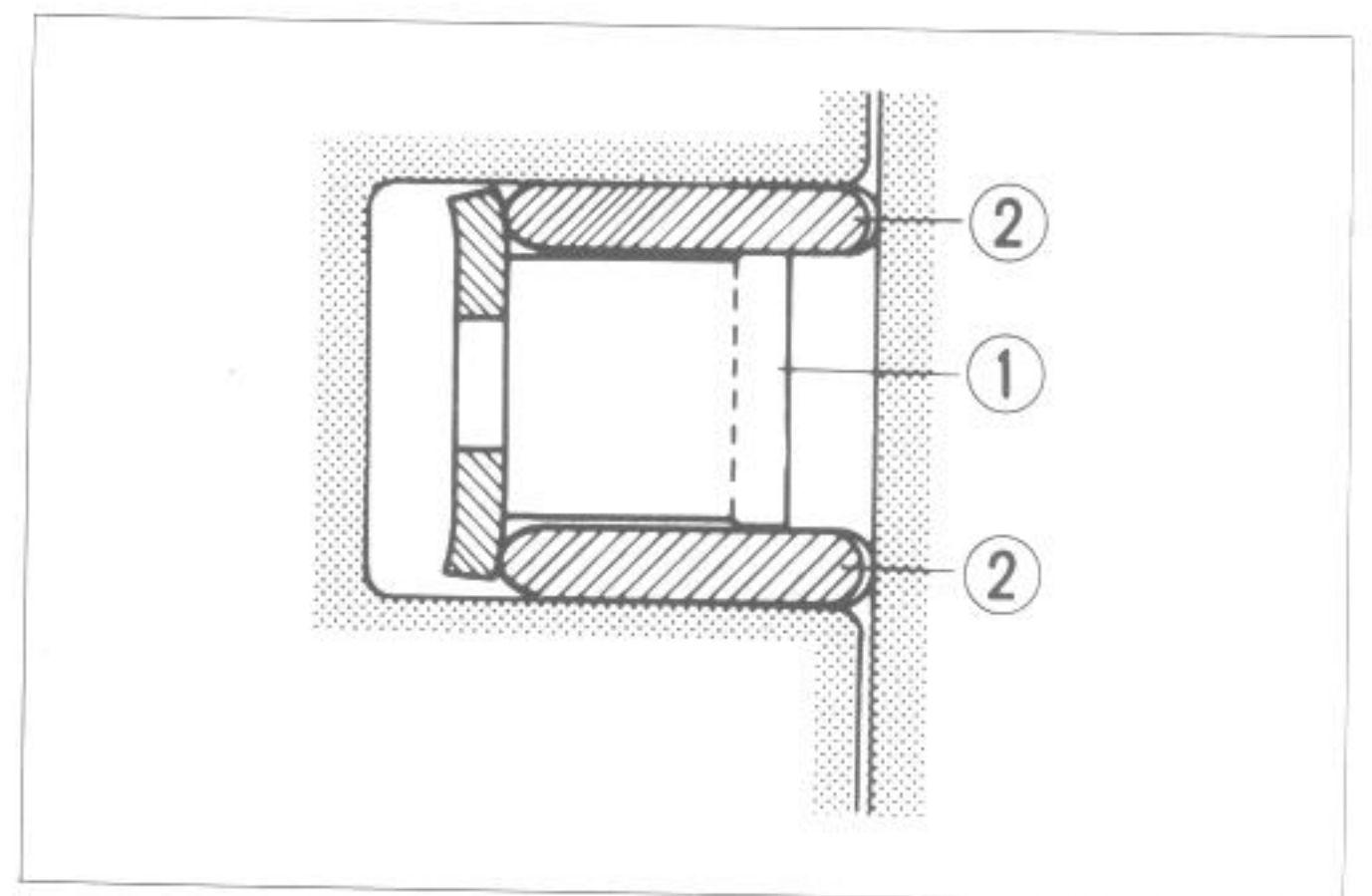

- Position the gaps of the three rings as shown. Before inserting each piston into the cylinder, check that the gaps are so located.

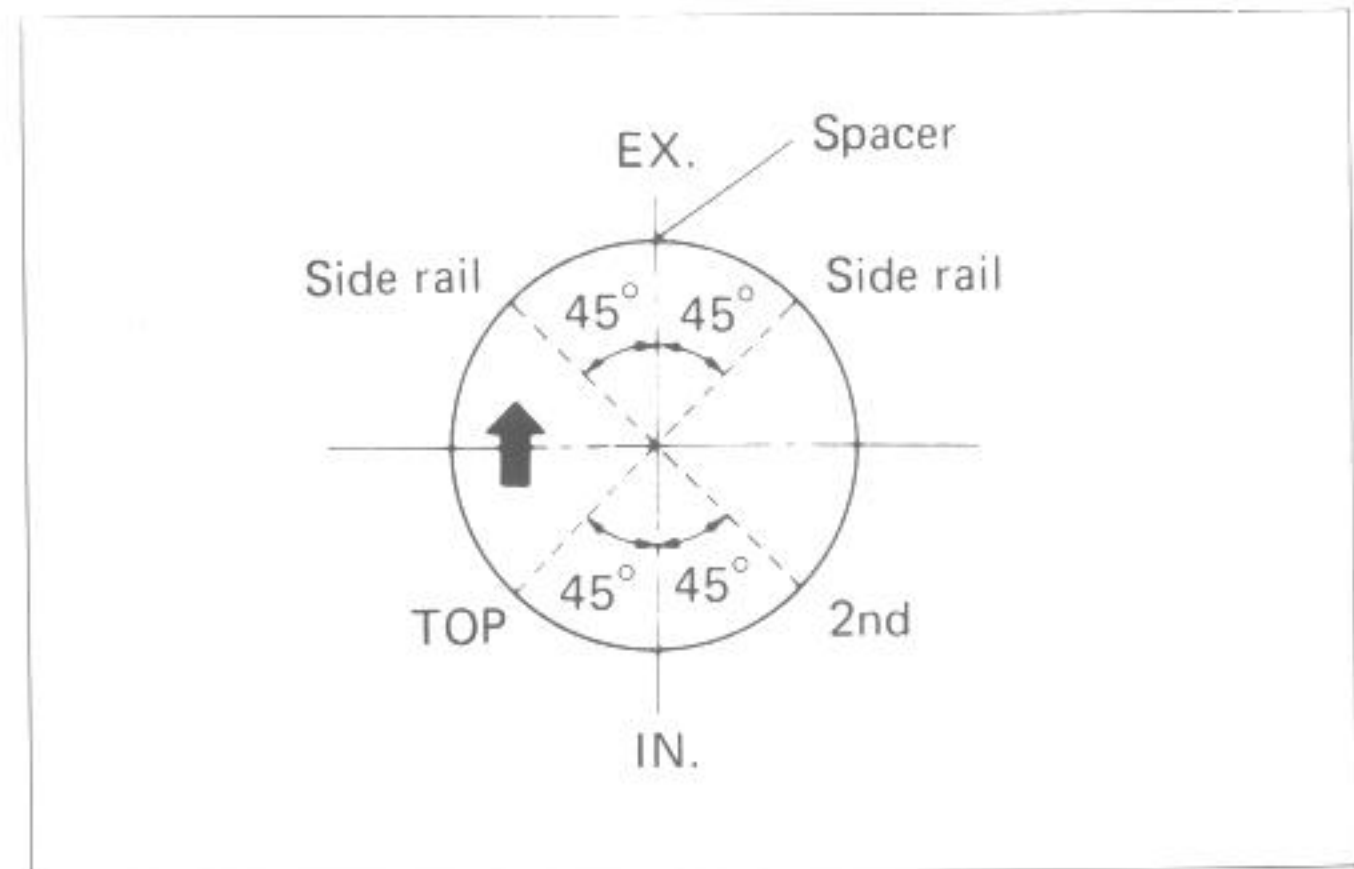

- Oil the big end bearings and small end of each connecting rod before mounting piston on the connecting rod.

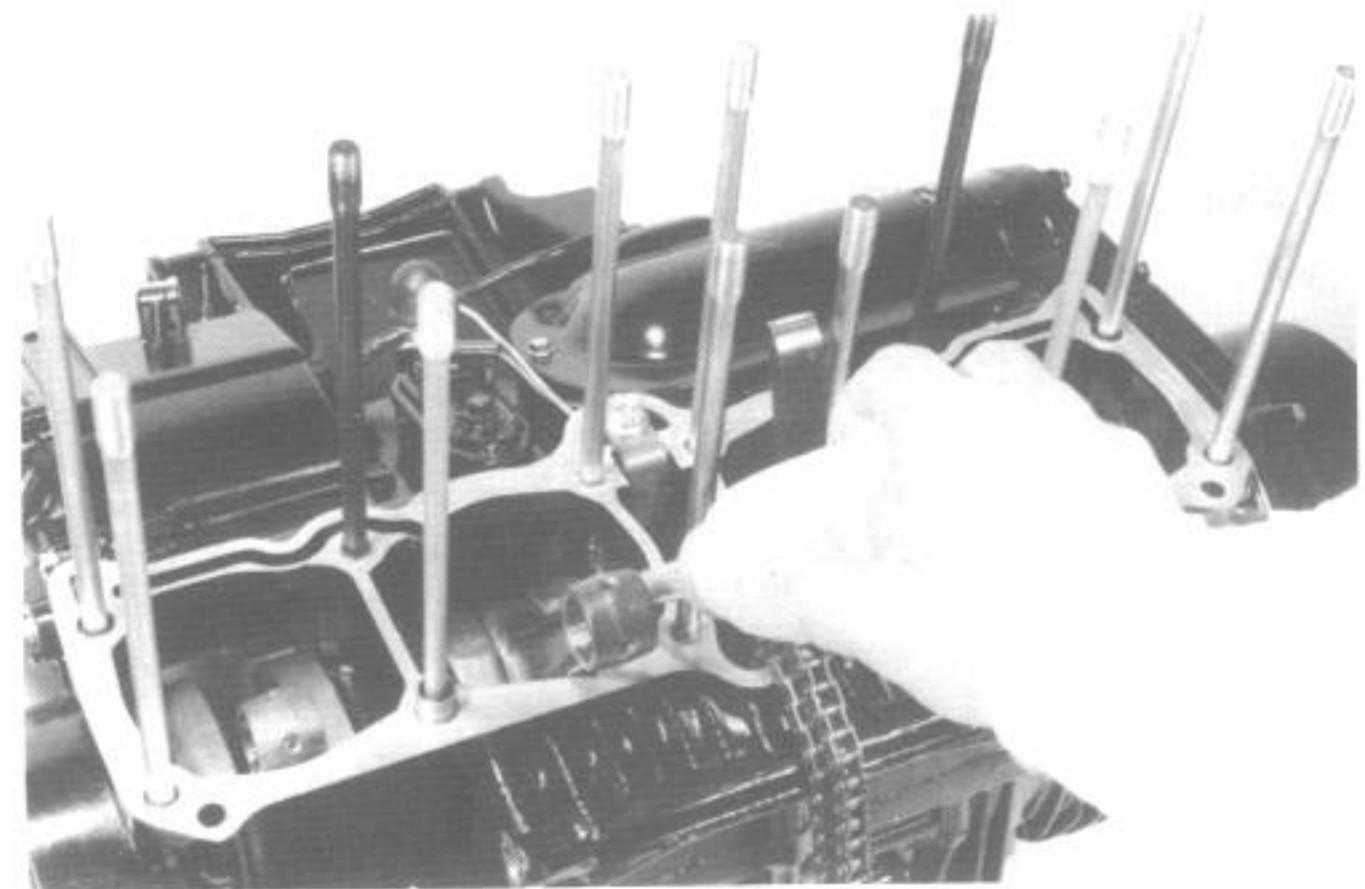

- When fitting the piston, turn arrow mark on the piston head to exhaust side.
- Be sure to install the pistons in the cylinder from which they were taken out in disassembly, refer to the letter mark, "1" through "4", scribed on the piston.

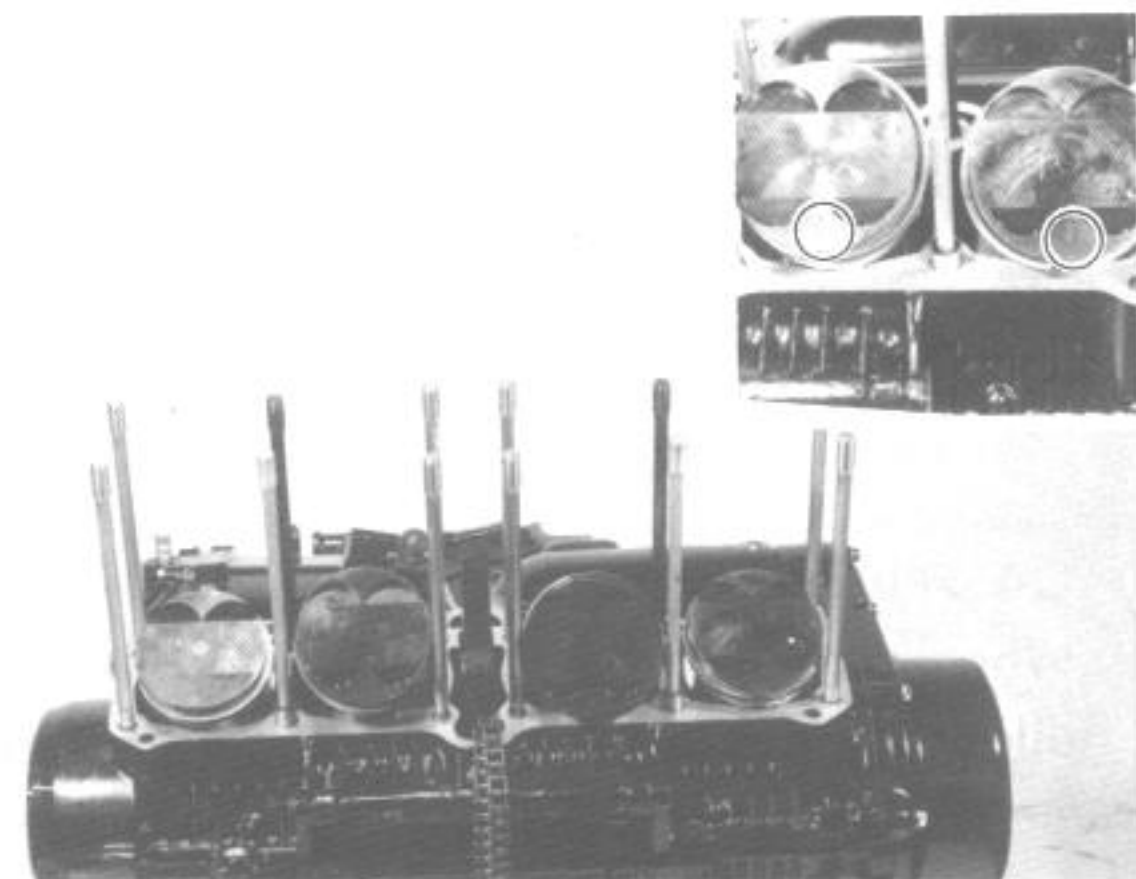

- Oil each piston lightly before installing it.
- Place a rag beneath the piston, and install the circlip.
- Be sure to use new circlips.

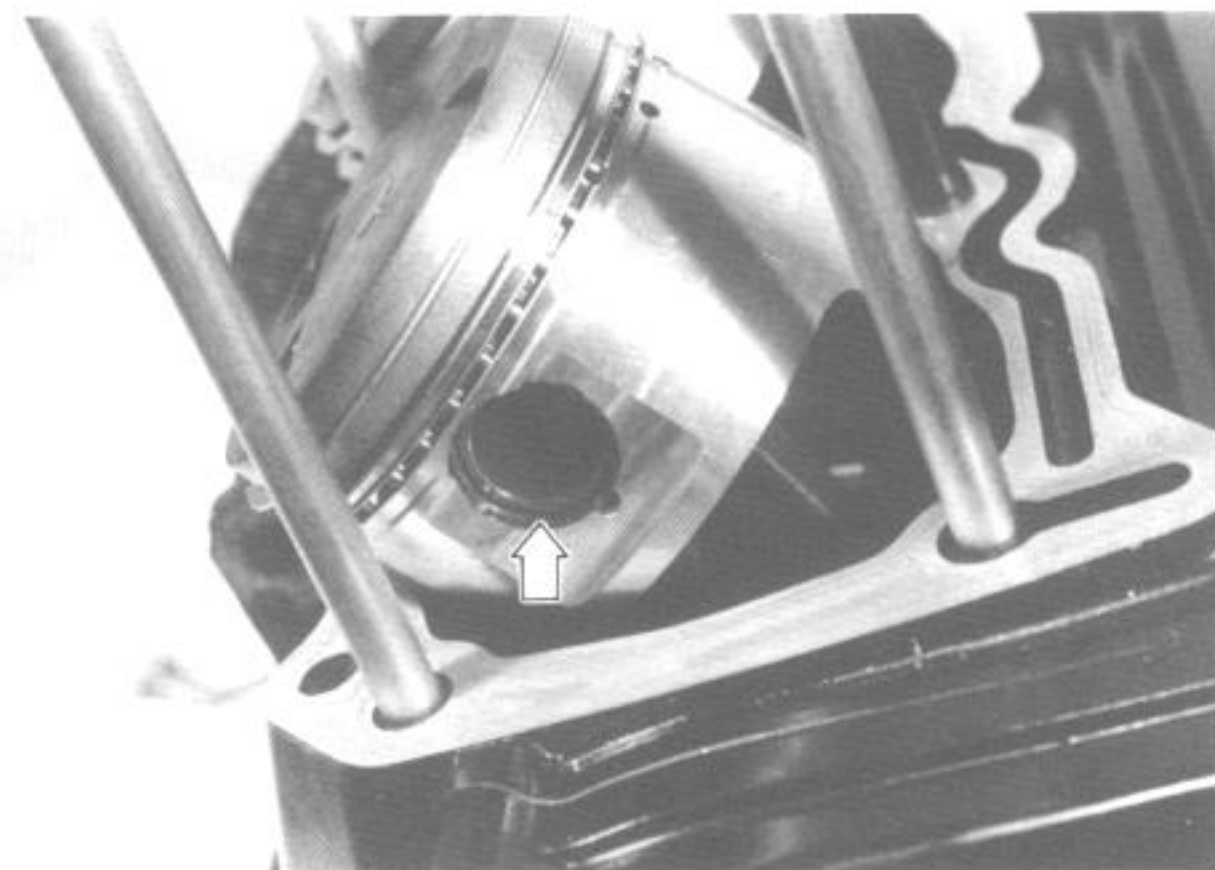

- Before putting on the cylinder block, oil the small ends of each connecting rod and also the sliding surface of each piston. Check to be sure that the O-rings ① are accurately positioned in the groove.

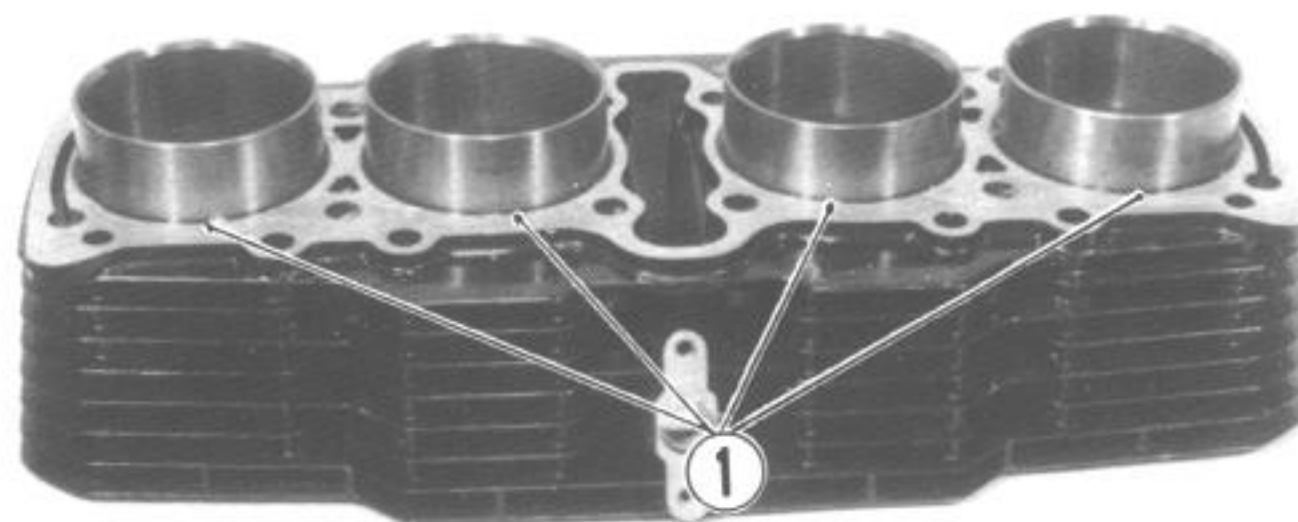

- Be sure to replace the cylinder gasket with new one to prevent gas leakage.

NOTE:

Be sure to identify the top surface by "UP" mark ② on the cylinder gasket as shown.

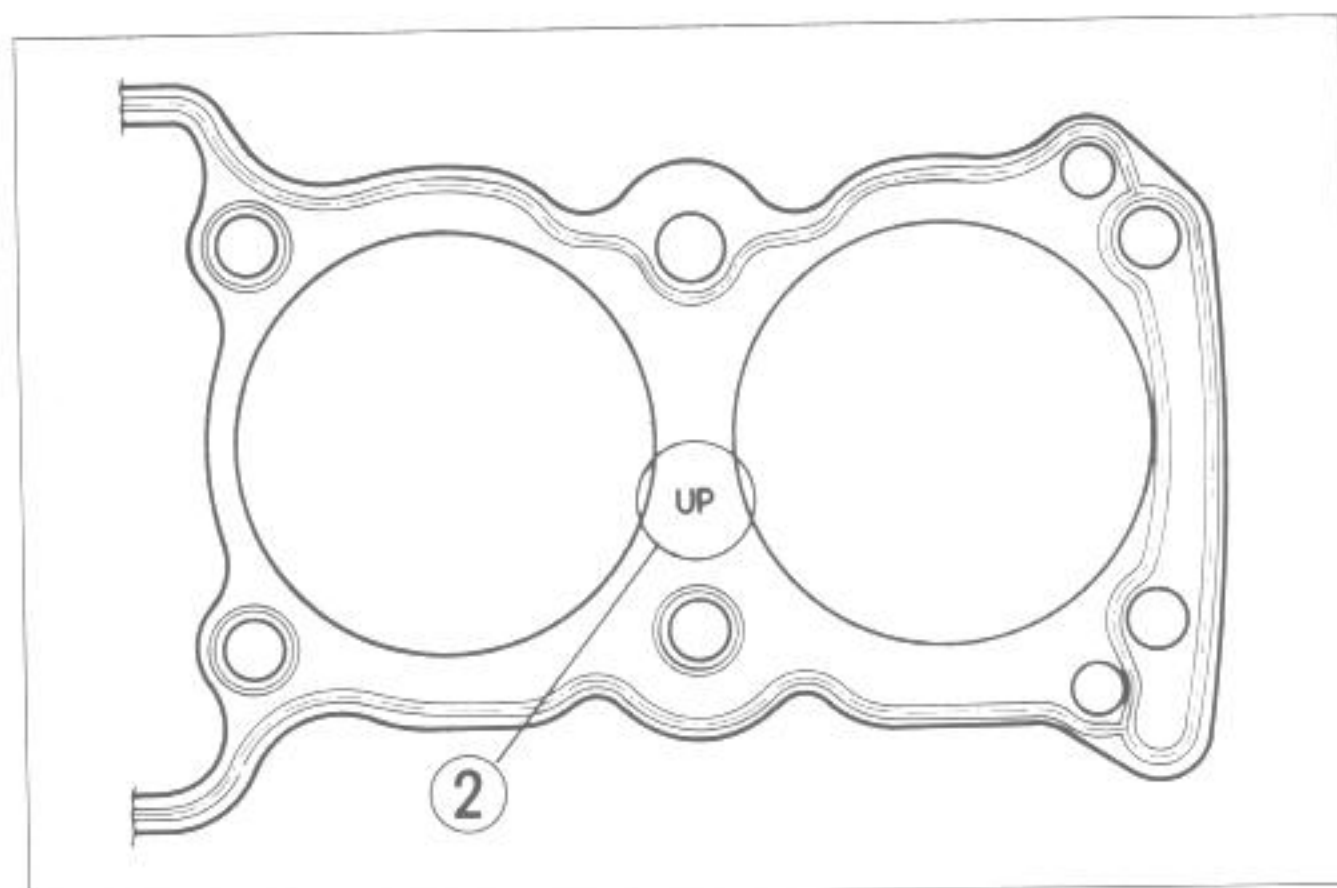

- Install piston ring holders in the indicated manner. Some light resistance must be overcome to lower the cylinder block.
- With No. 2 and No. 3 pistons in place, install No. 1 and No. 4 pistons and insert them into the cylinder.

09916-74520	Holder body
09916-74540	Band (bore 63 – 75 mm)

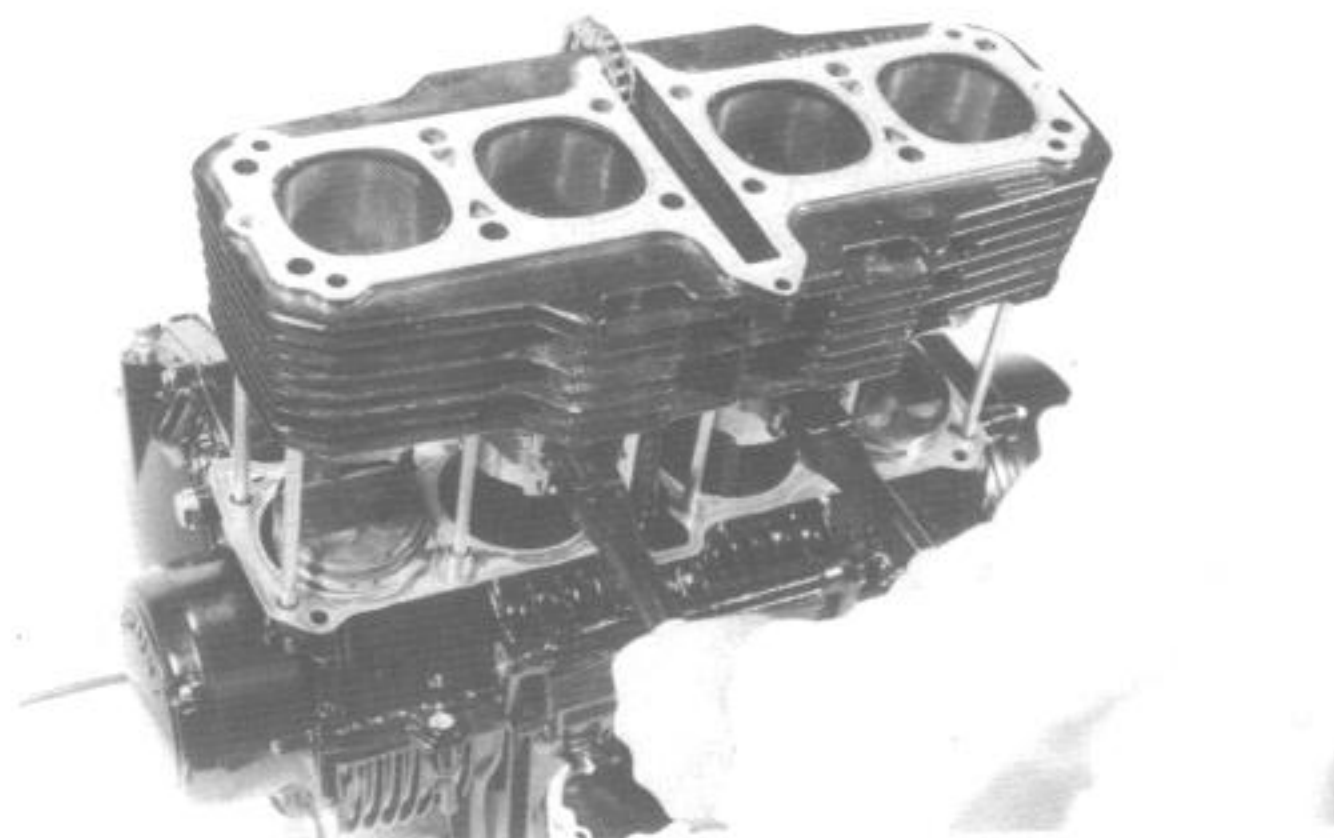
**NOTE:**

- * The extra friction will prevent the cylinder from sliding easily onto the pistons.
- * Each band has a number punchmarked on it. The number refers to a particular range of piston sizes.

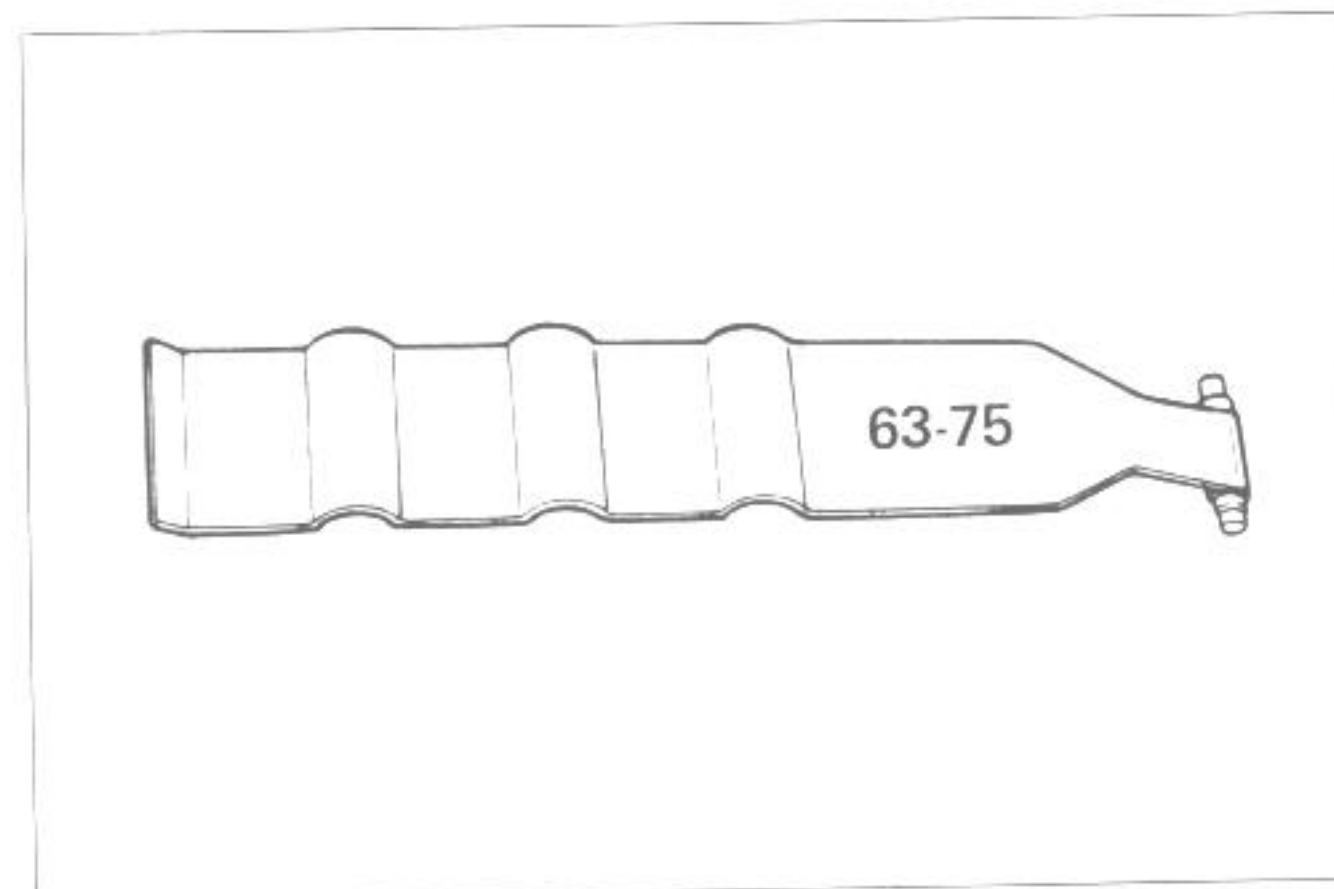

- Be sure to replace the cylinder head gasket with new one to prevent gas leakage.

NOTE:
 Be sure to identify the top surface by "HEAD" mark on the cylinder head gasket as shown.

- Fix two knock pins properly.
- Mount the cylinder head on the cylinder block.
- Install two kinds of cylinder head nuts in the respective positions indicated.
- Tighten the twelve 10-mm nuts to specification with a torque wrench sequentially in the ascending order of numbers.

Tightening torque	35 – 40 N·m (3.5 – 4.0 kg-m)
-------------------	---------------------------------

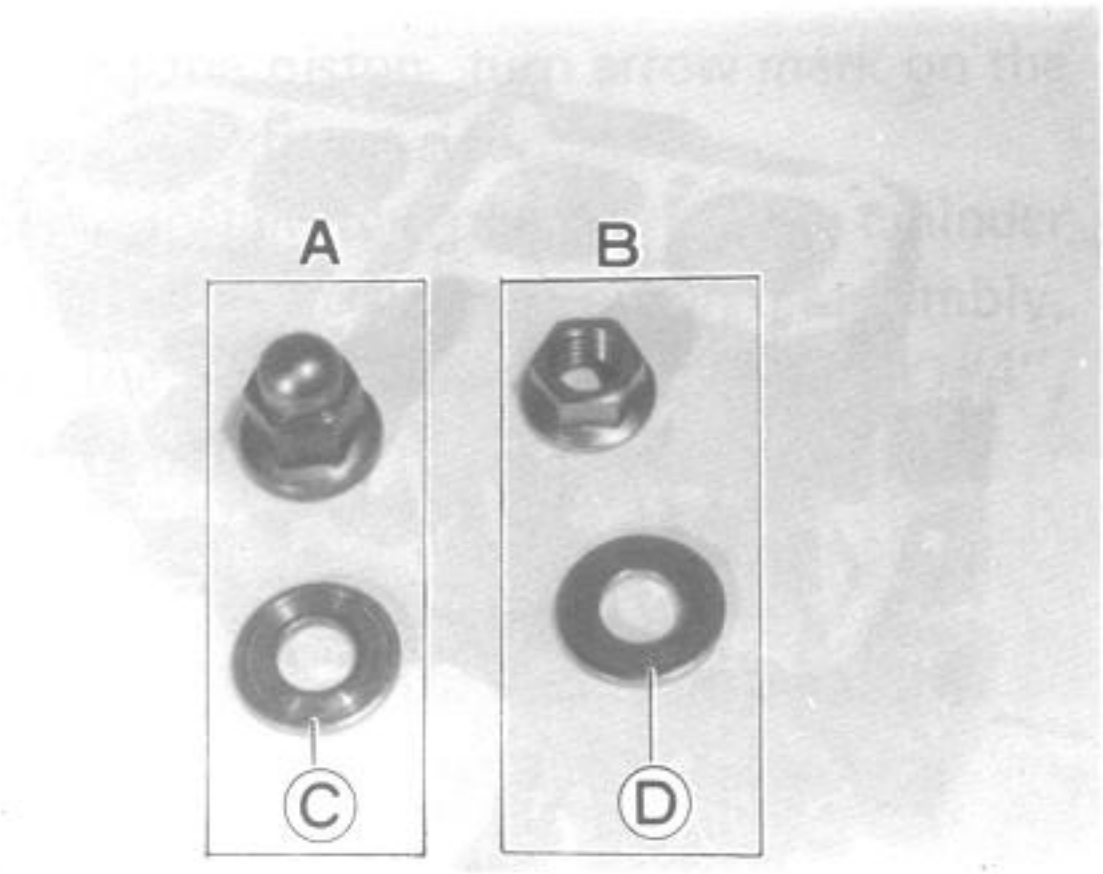
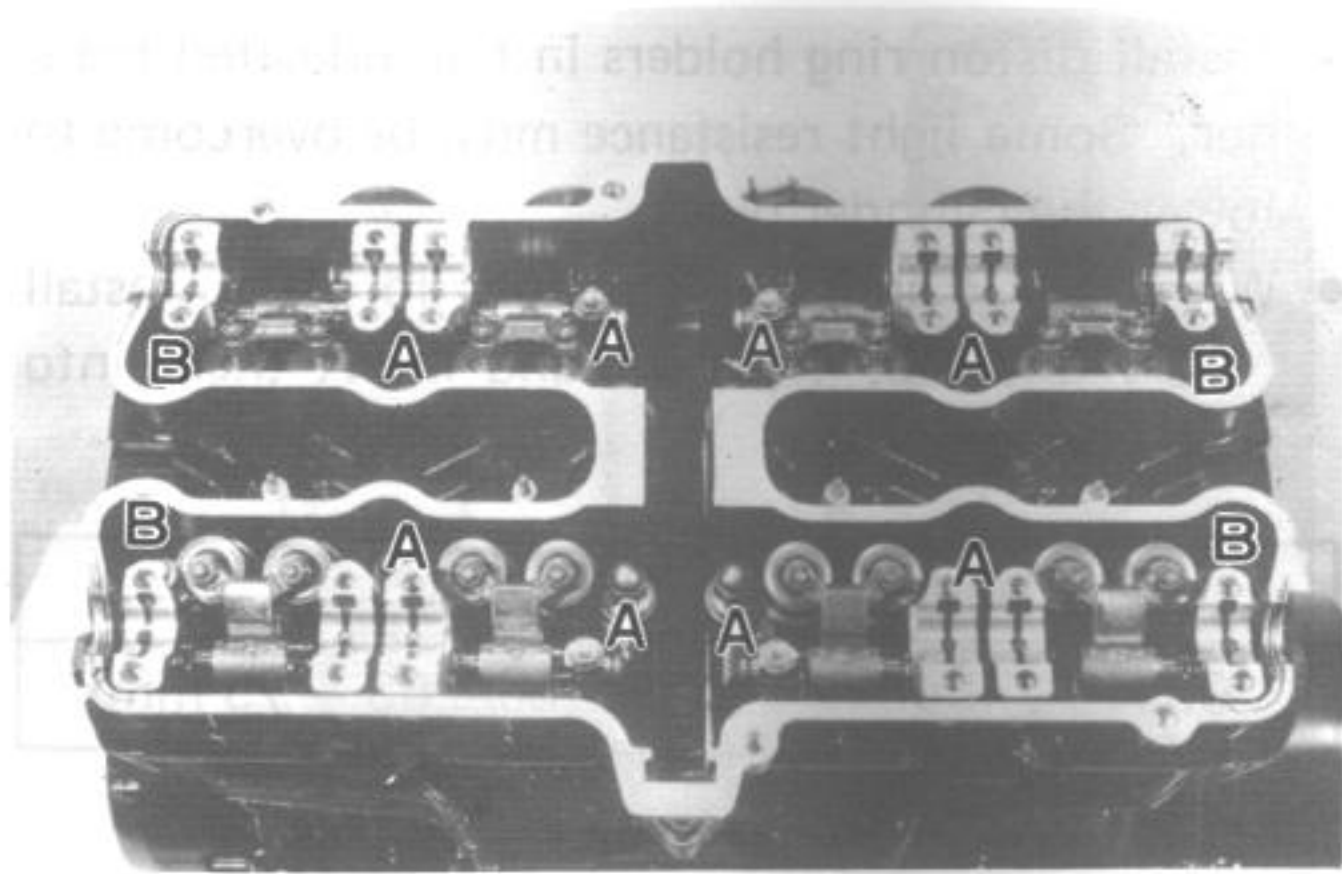
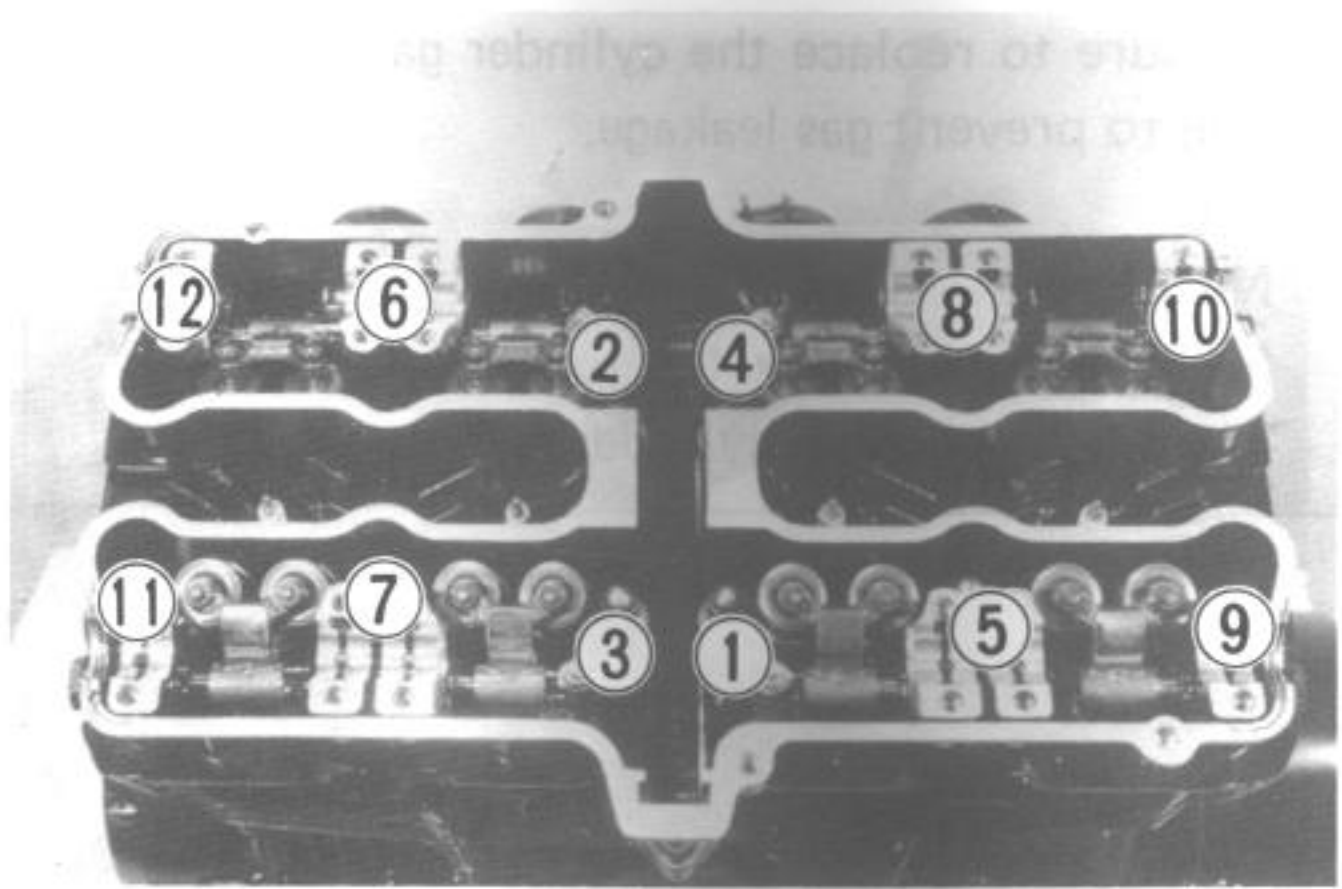
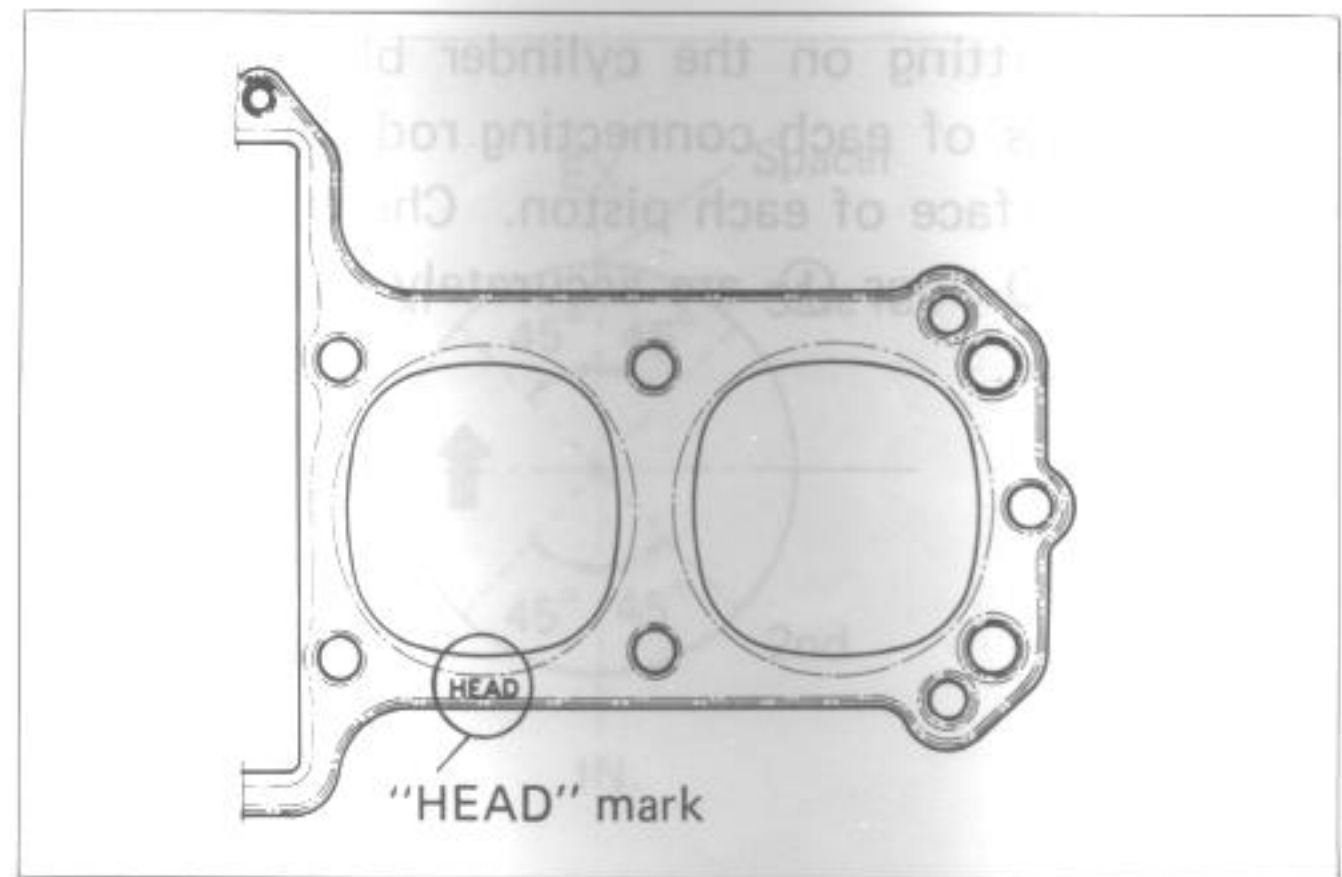

© Copper washer ④ Iron washer

- After firmly tightening the 12-nuts, insert the 6-mm bolt and tighten it with specified torque.

Tightening torque	7 – 11 N·m (0.7 – 1.1 kg-m)
-------------------	--------------------------------

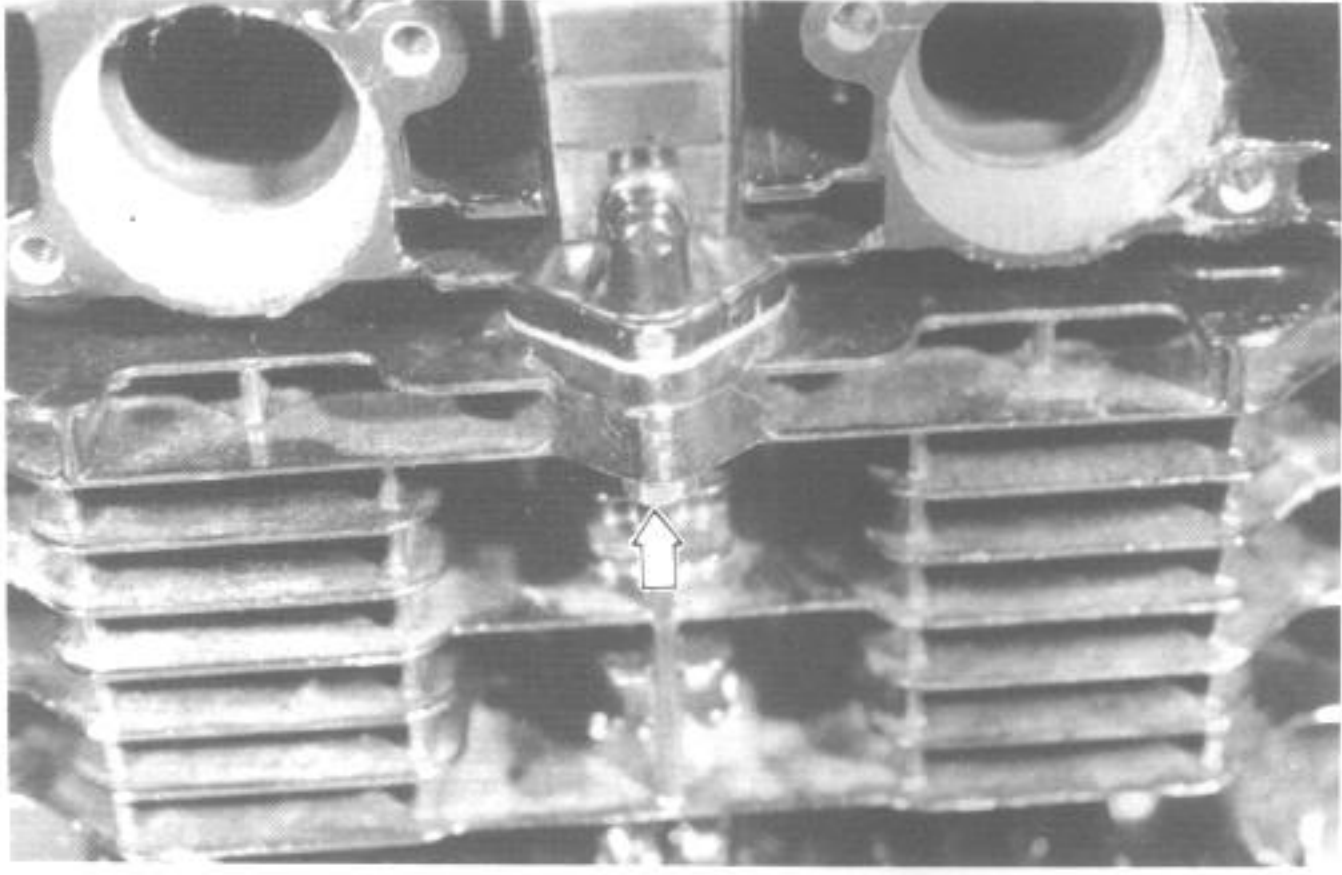

- Place the chain guide properly.

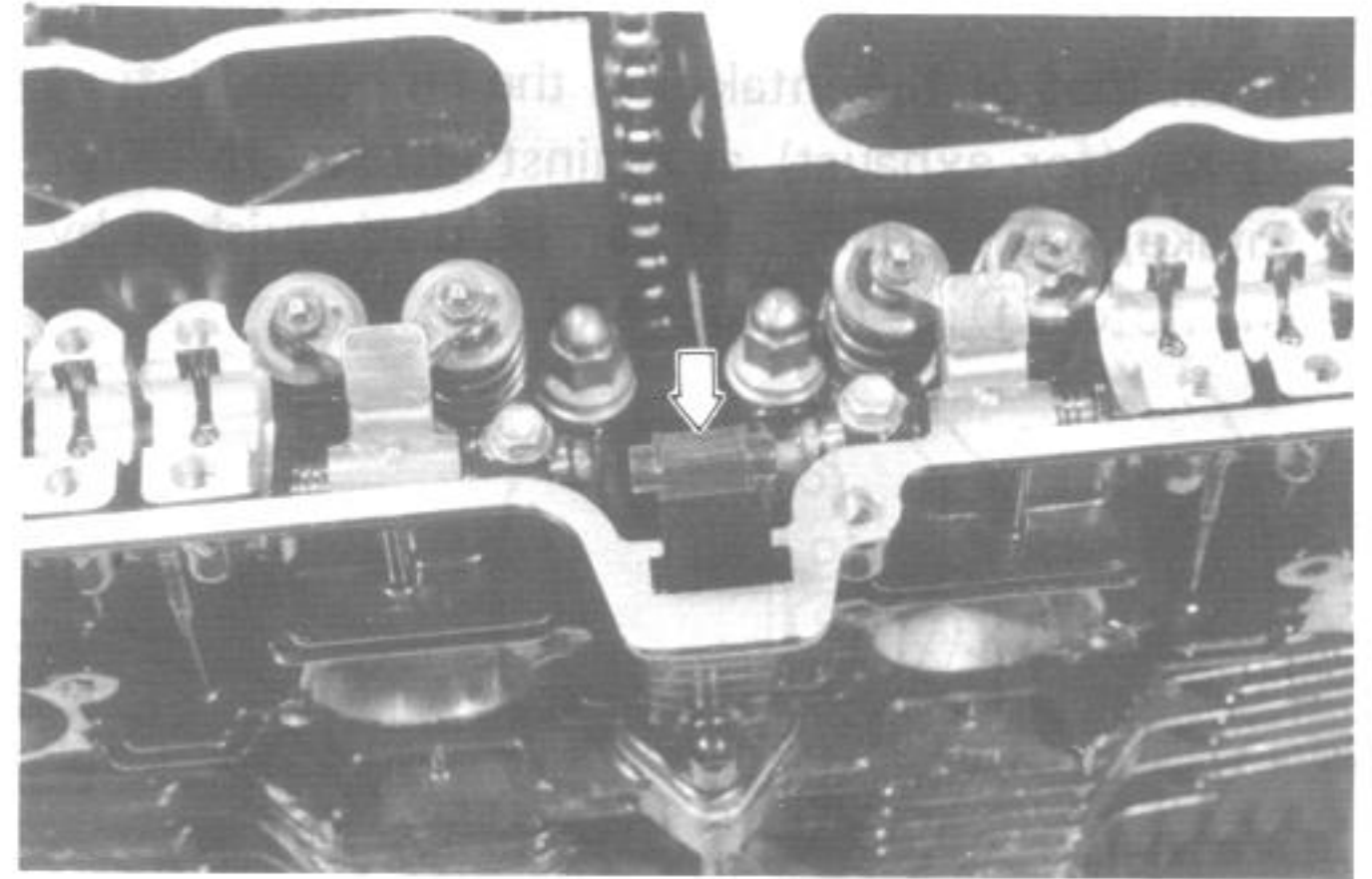

- While holding down the timing chain, rotate the crankshaft in normal direction to bring the "T" mark on the rotor to the center of left pick up coil.

CAUTION:

To turn over crankshaft, turn the torque nut with a 19 mm wrench. Never try to rotate crankshaft by putting a 6 mm hexagon wrench to bolt.

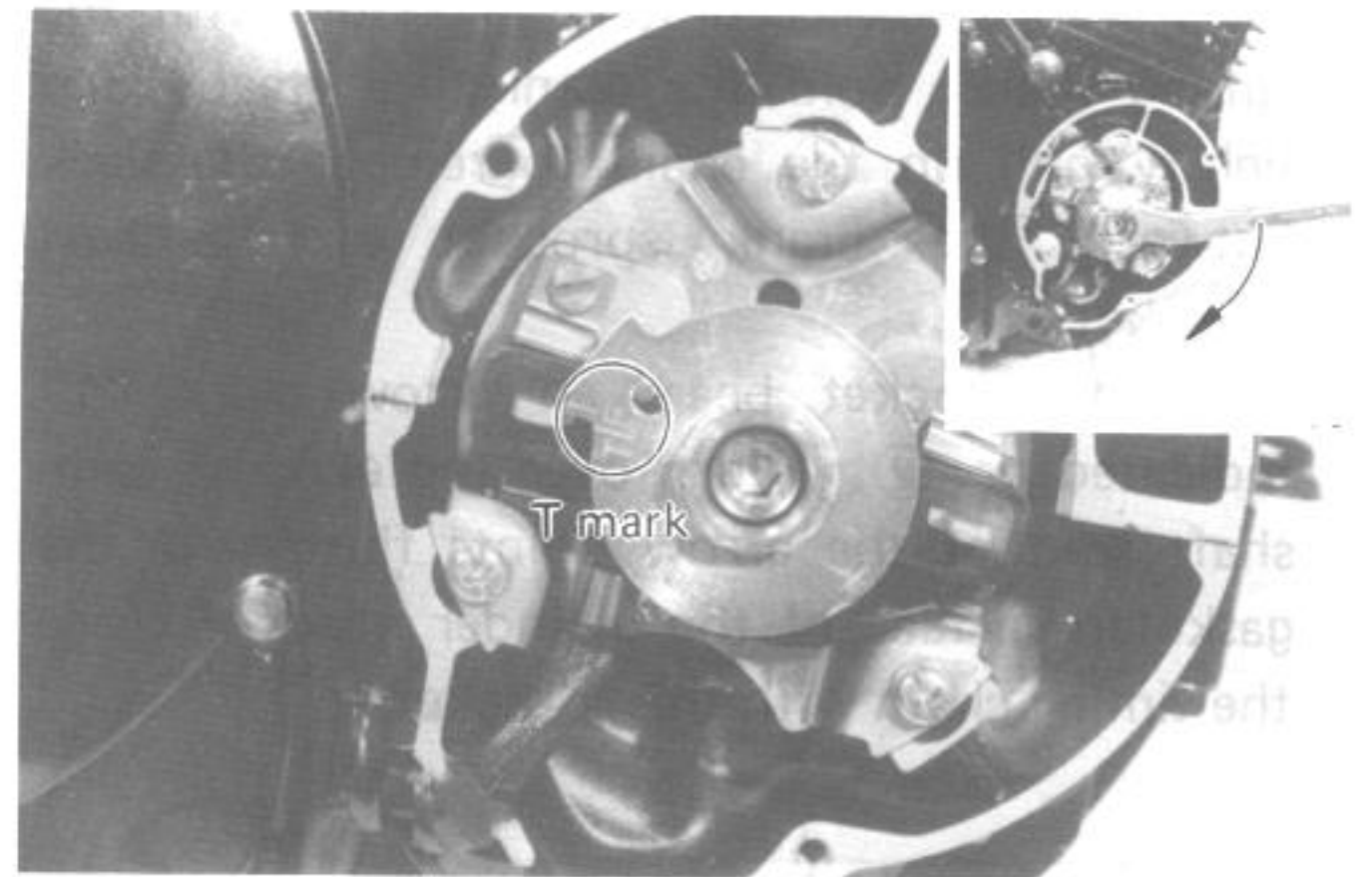

NOTE:

Just before placing the camshaft on the cylinder head, apply high quality molybdenum disulfide lubricant to its journals, fully coating each journal with the paste taking care not to leave any dry spot. Apply engine oil to the journal bearings.



99000-25140

SUZUKI Moly Paste

- The exhaust camshaft can be distinguished from that of the intake by the embossed letters "EX" (for exhaust) as against letters "IN" (for intake). The right end can be distinguished by the notch ① at the right end.

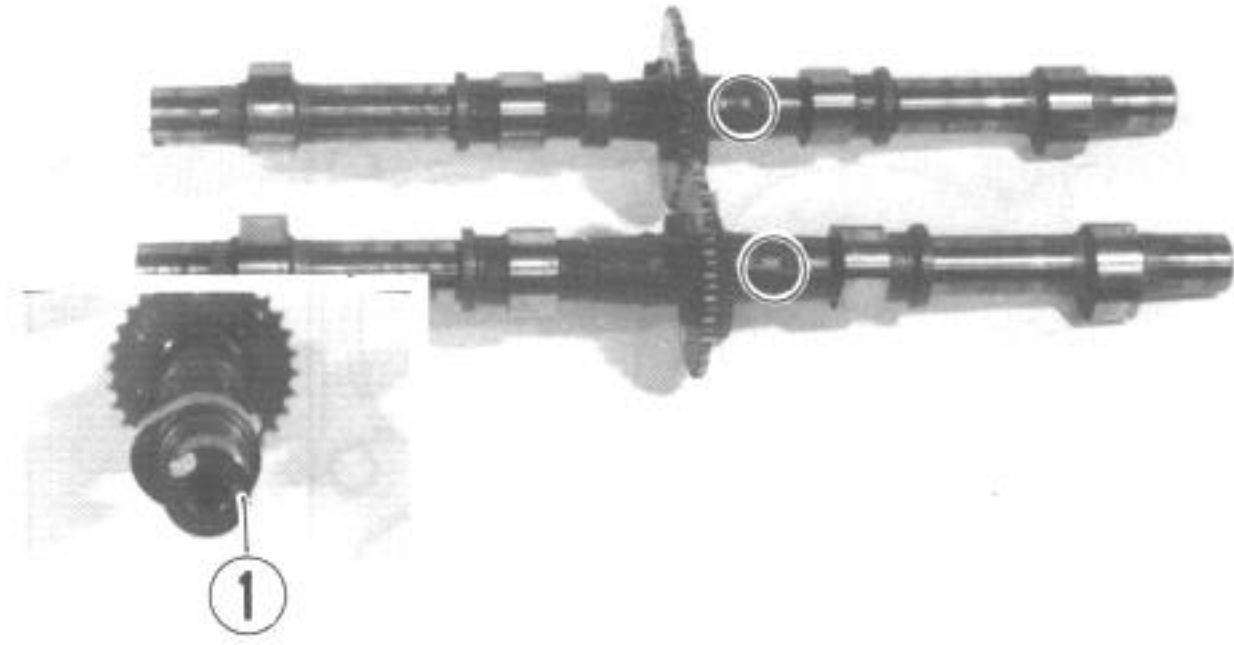

- With "T" mark accurately lined up with the timing mark, hold the crankshaft steady and lightly pull up the chain to remove the slack between the crank sprocket and exhaust sprocket.
- Exhaust sprocket bears an arrow mark "1" indicated as ②. Turn over the exhaust camshaft so that the arrow points flush with the gasketed surface of the cylinder head. Engage the timing chain with this sprocket.

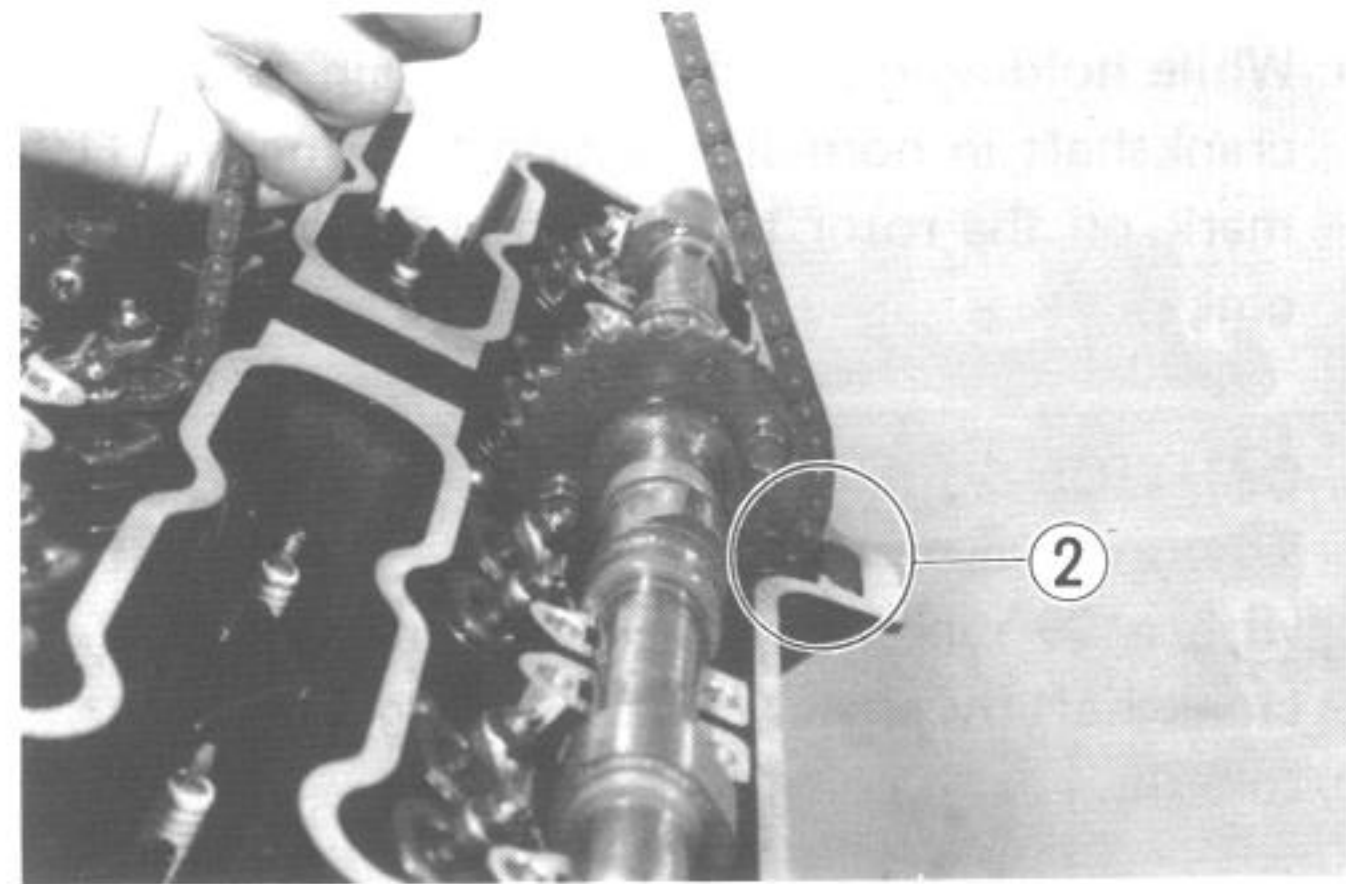

- The other arrow marked "2" is now pointing straight upward. Count the chain roller pins toward the intake camshaft, starting from the roller pin directly above this arrow marked "2" and ending with the 20th roller pin. Engage the chain with intake sprocket, locating the 20th pin at and above the arrow marked "3" on the intake sprocket.

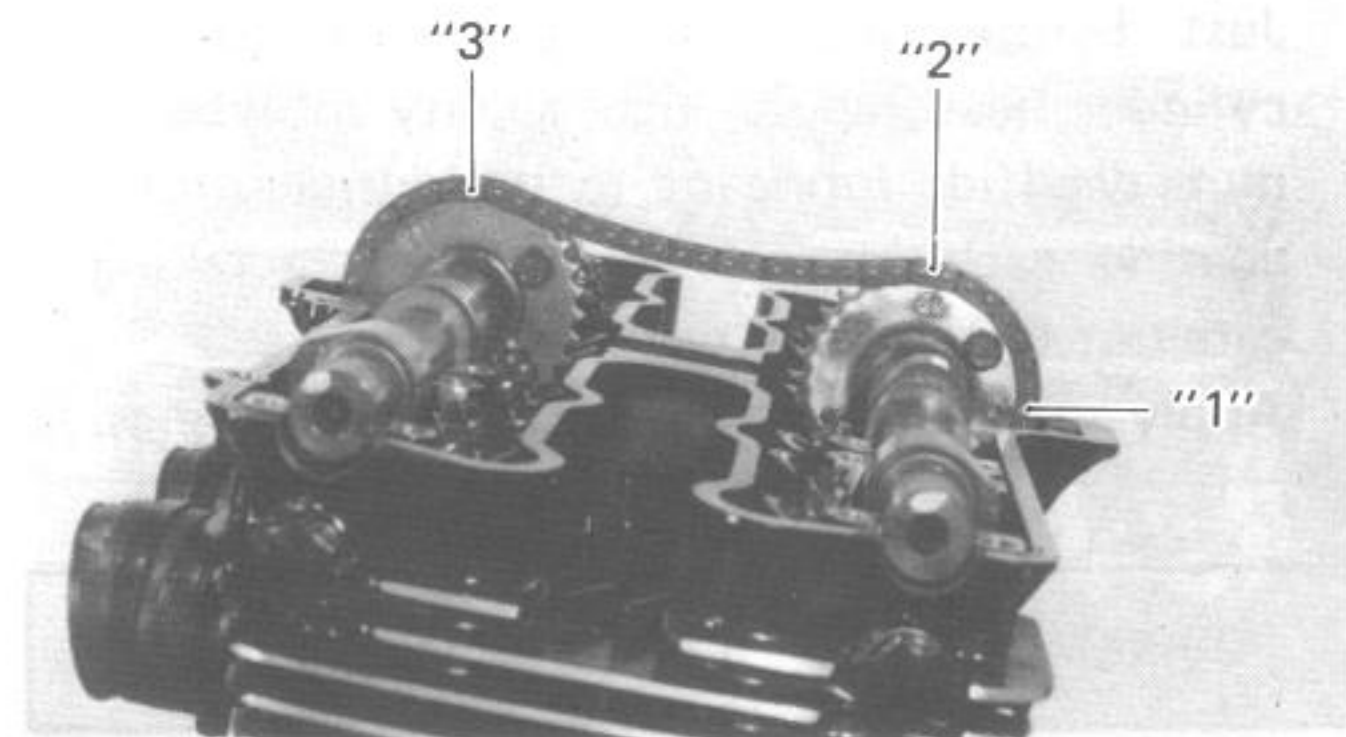
**NOTE:**

The timing chain is now riding on all three sprockets. Be careful not to disturb the crankshaft until the eight holders are secured and the chain tensioner is fitted.

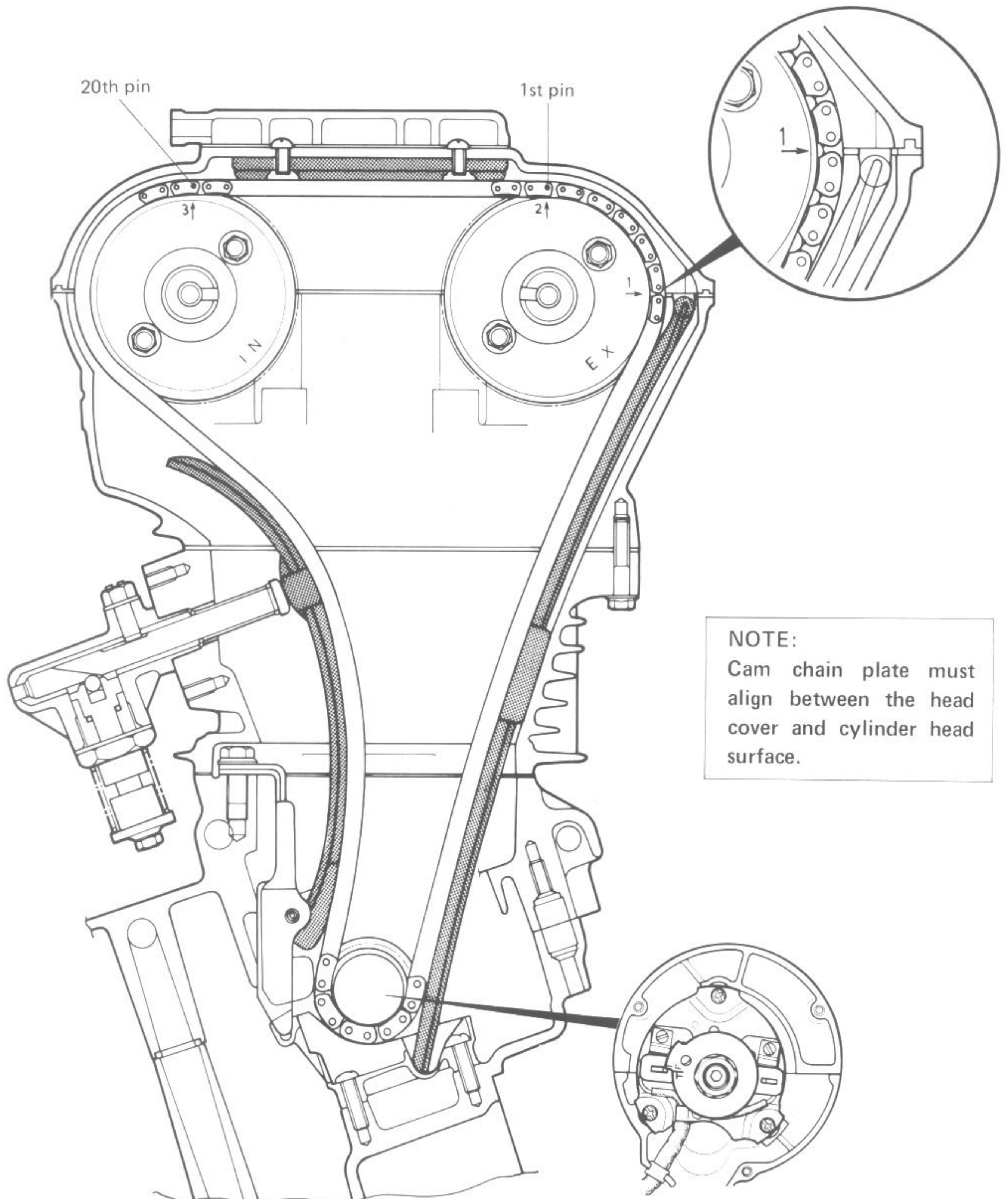

- Each camshaft holder is identified with a cast-on letter with a triangle. A matching cast-on symbol appears on the head. Install each holder at its matching letter, with triangle symbols pointing forward.
- Secure the eight camshaft journal holders evenly by tightening the camshaft journal holder bolts sequentially. Try to equalize the pressure by moving the wrench diagonally from one bolt to another and from one camshaft journal holder to another, to push shafts down evenly.

NOTE:

Damage to head or cam journal holder thrust surfaces may result if the cam journal holders are not drawn down evenly.

- Tighten the camshaft journal holder bolts to the following torque value:

Tightening torque	8 – 12 N·m (0.8 – 1.2 kg-m)
-------------------	--------------------------------

CAUTION:

The camshaft journal holder bolts are made of a special material and much superior in strength compared with other type of high strength bolts.

Take special care not to use other type bolts instead of these special bolts. To identify these bolts, each of them has a figure "9" on its head.

- While turning lock shaft handle counterclockwise, push in the pushrod all the way. Keep on turning the handle until it refuses to turn further.
- Tighten the lock screw to lock the pushrod, so that the pushrod will not plunge out.
(Refer to page 3-32 for details)

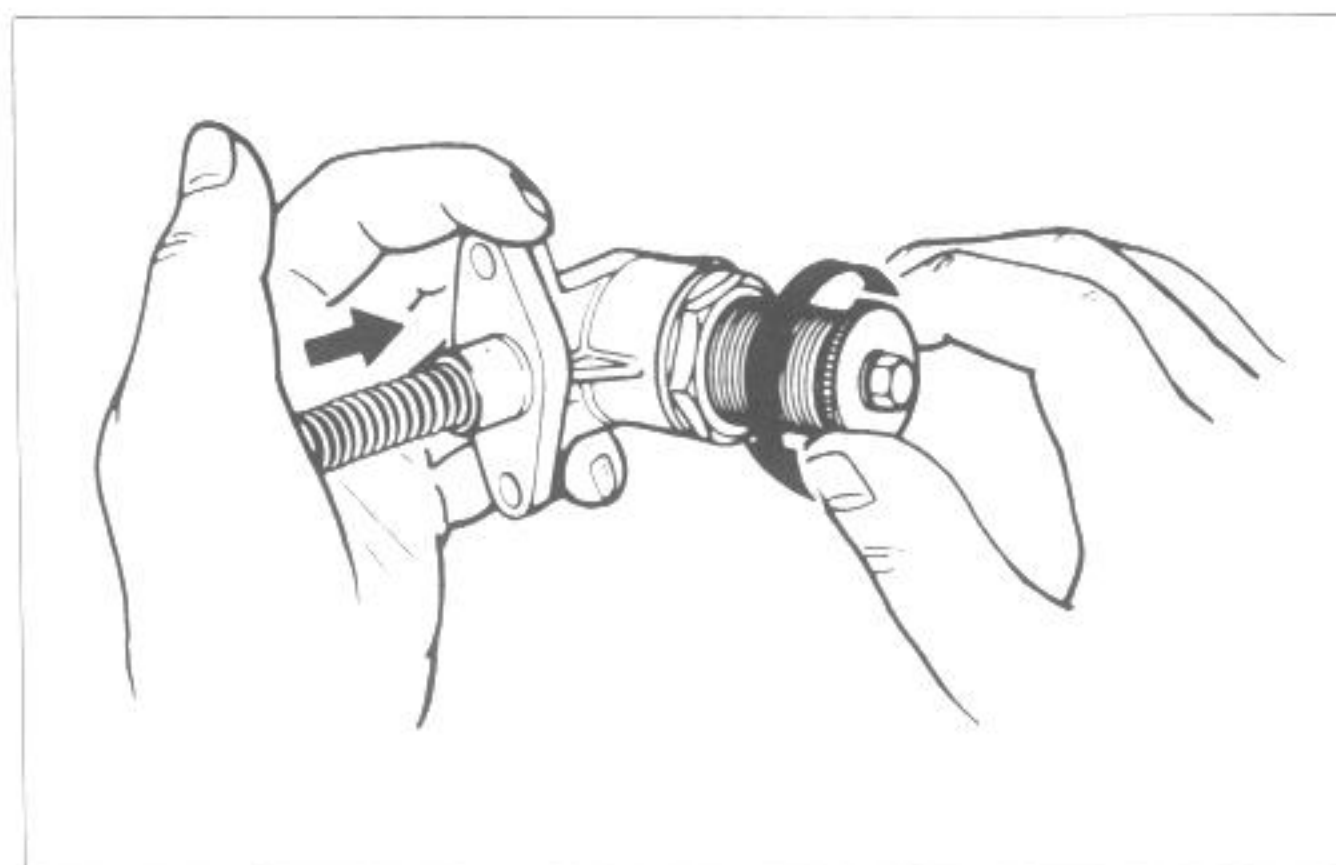
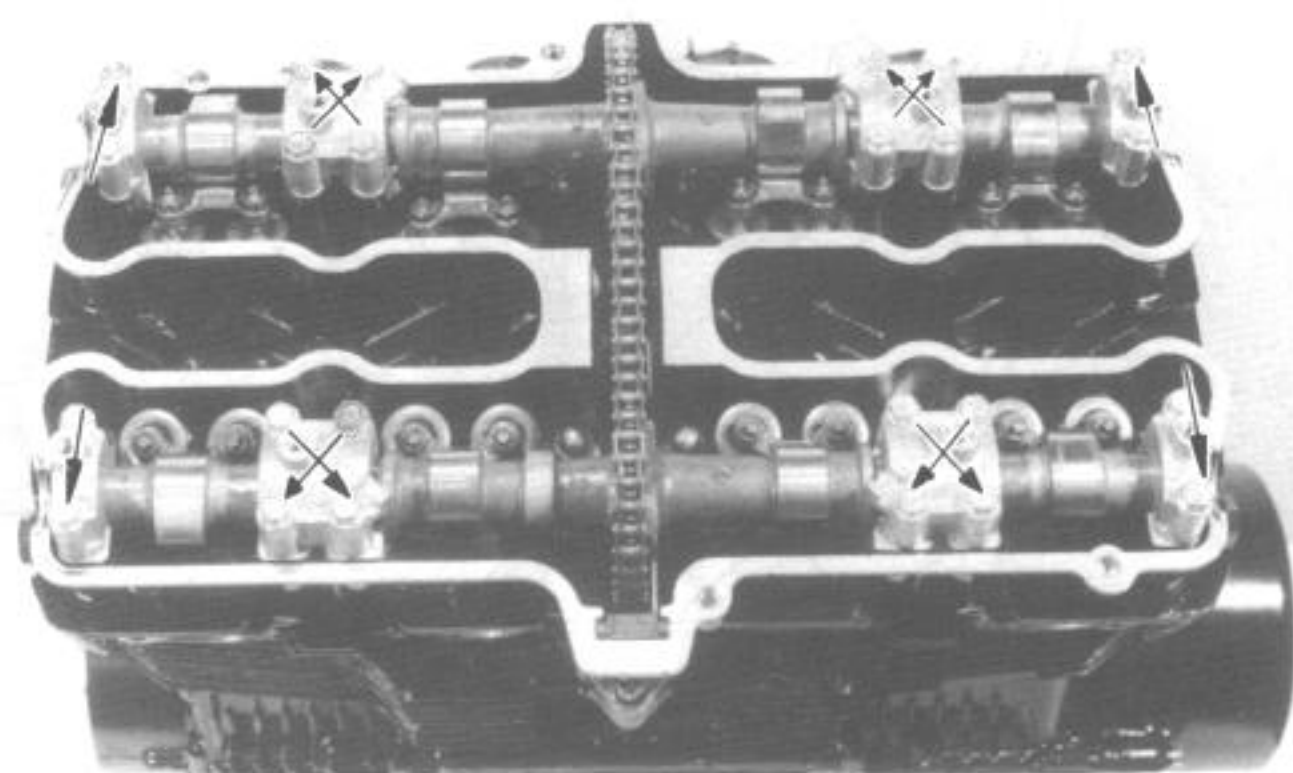
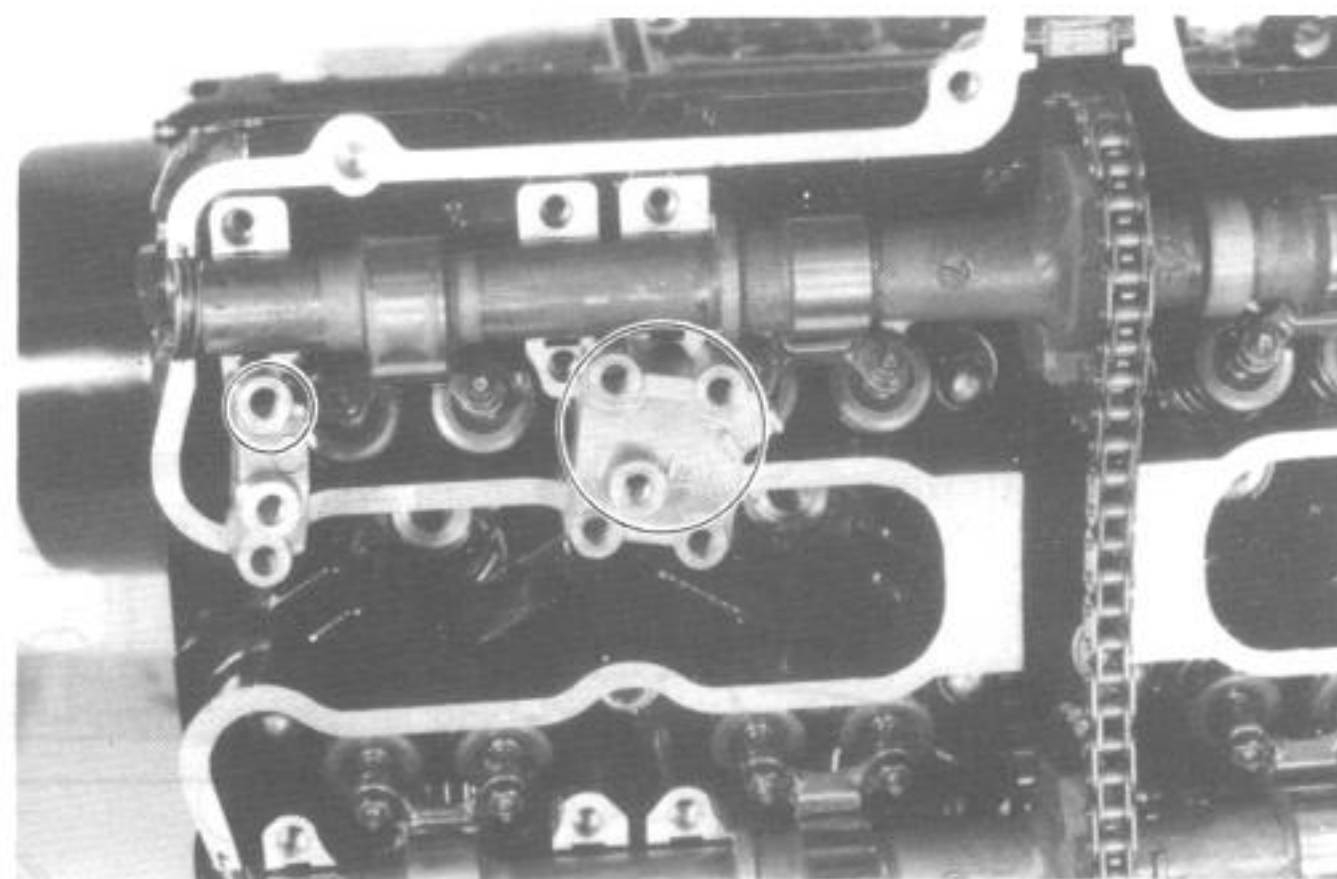

- Mount the cam chain tensioner to the cylinder block.

Tightening torque	6 – 8 N·m (0.6 – 0.8 kg-m)
-------------------	-------------------------------

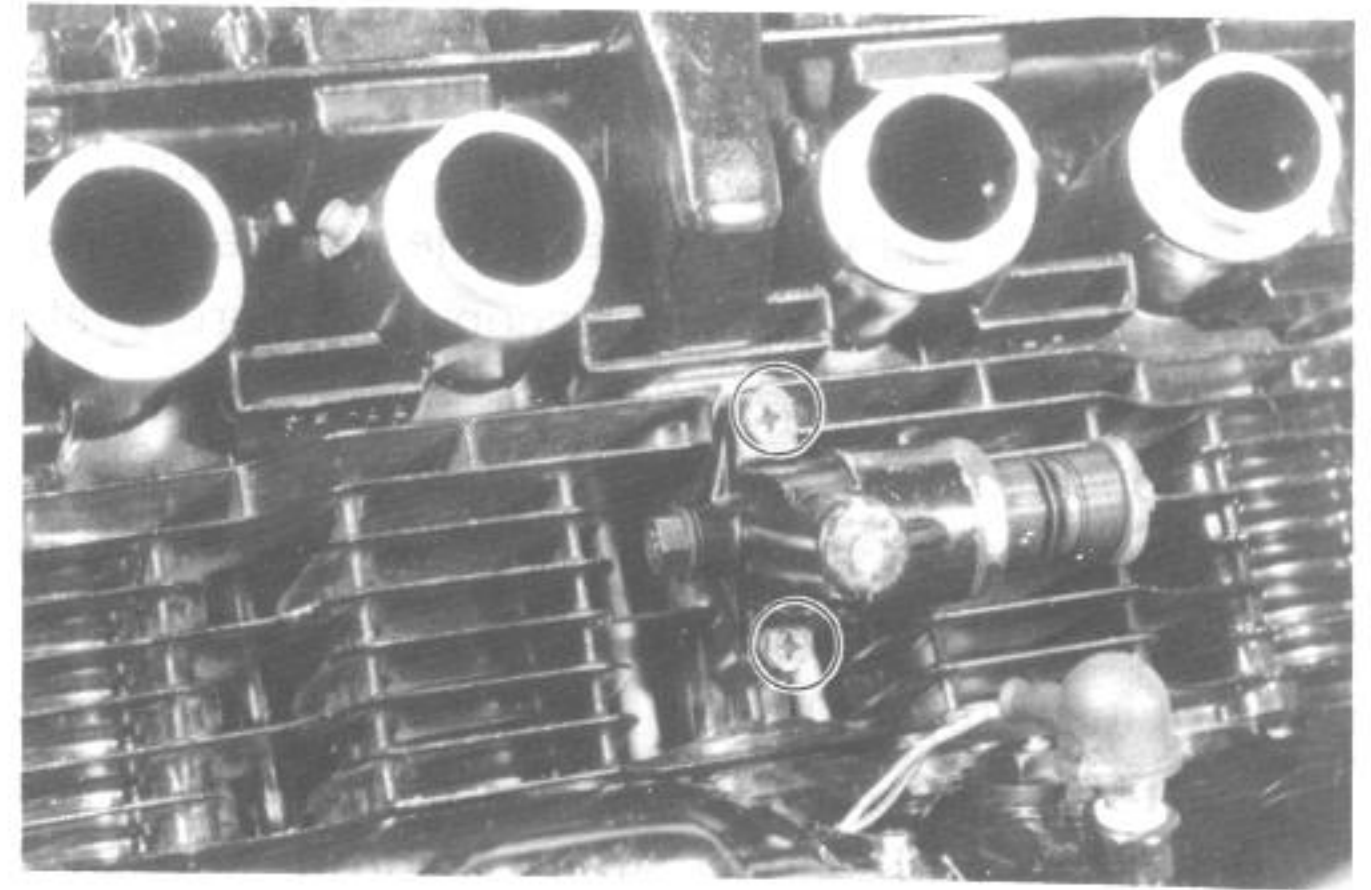

- If tensioner adjuster is not going in, turn the crankshaft slowly and slightly clockwise to get chain play at inlet side.

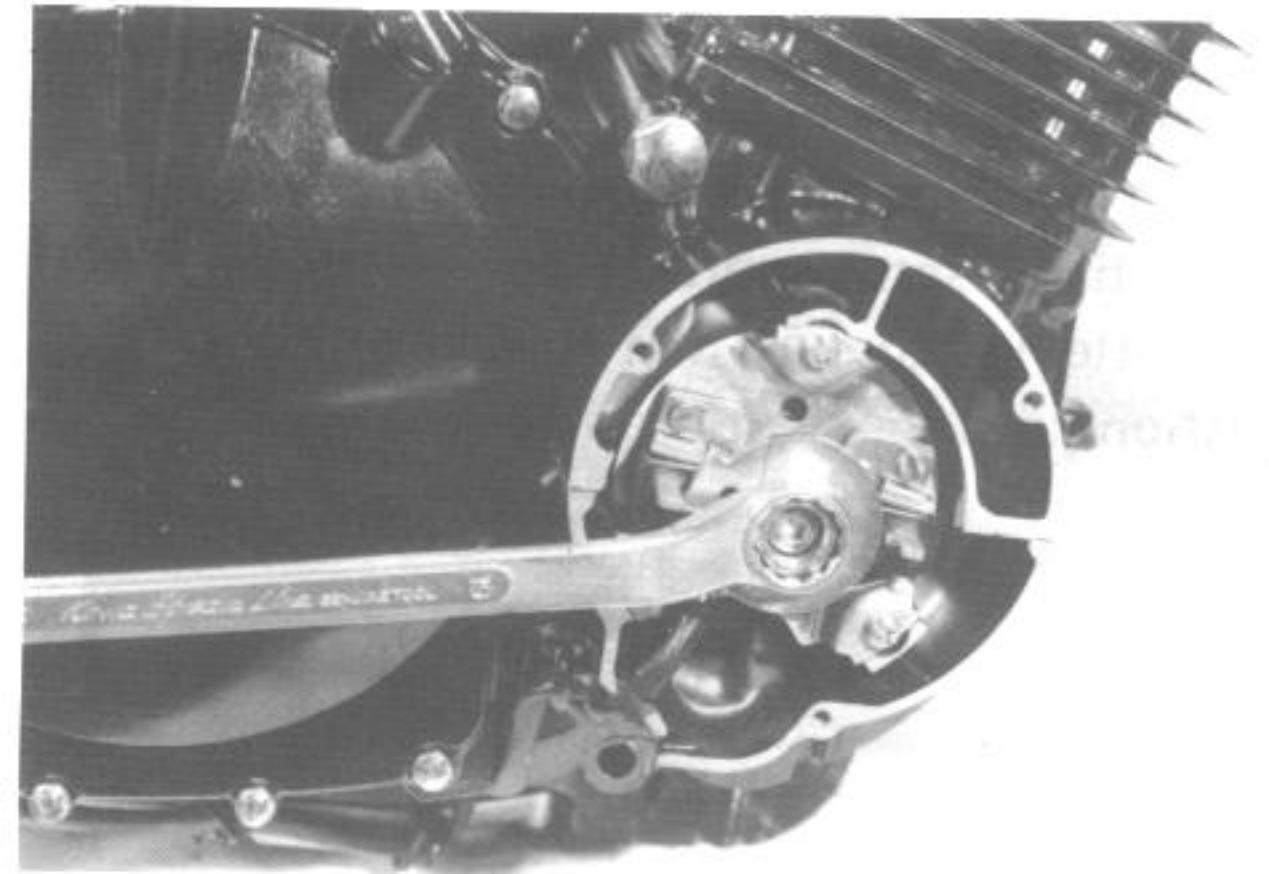

- Withdraw the lock screw by one-quarter to half a turn: this separates the tip of the screw from the pushrod, thereby allowing the pushrod to advance under spring force and press the tensioner against the camshaft drive chain.
- Tighten the lock nut ①.

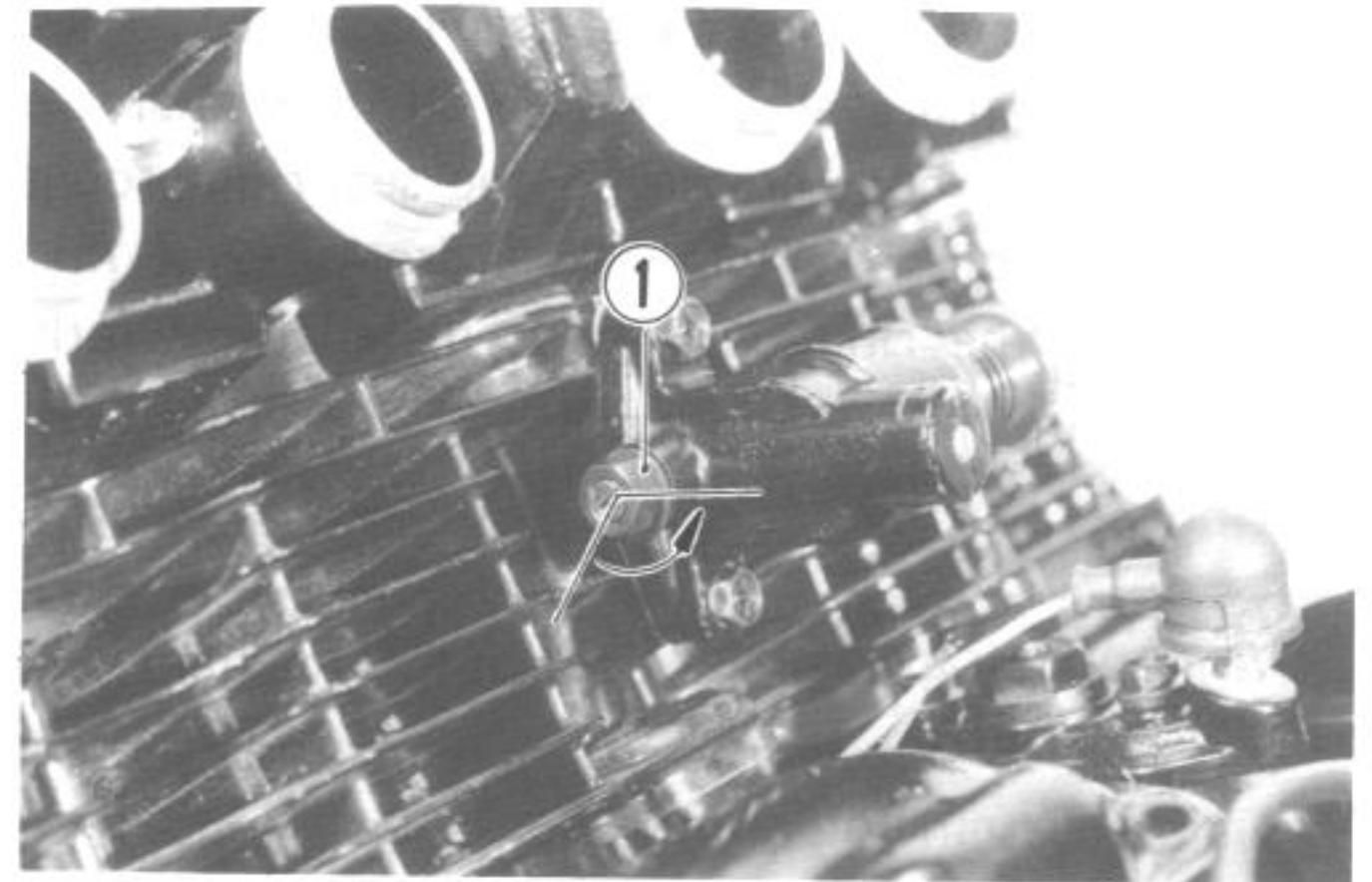

NOTE:

When tightening the lock nut, take care to prevent the lock screw from turning.

- While turning the handle ② counterclockwise, slowly rotate the crankshaft in reverse direction (thus causing the chain to push back the tensioner).

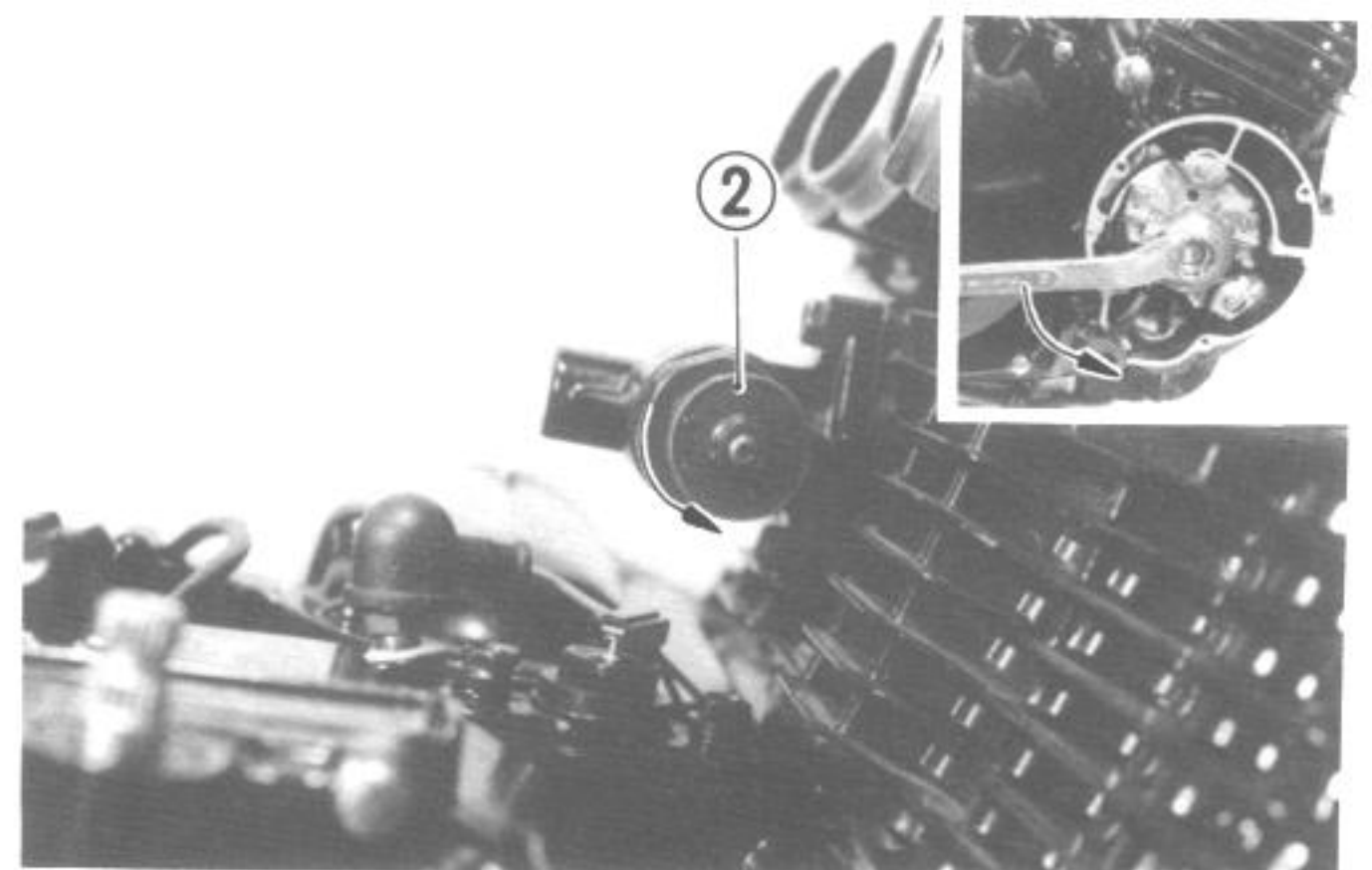

- Release the handle and slowly turn back the crankshaft in normal running direction (to slacken that portion of the chain extending along the tensioner). See if the handle rotates by itself as the chain becomes progressively slackened; if it does then the pushrod inside is obviously moving forward under spring force as it should, thus signifying that the tensioner is in good operable condition. If the handle rotates, but sluggishly, it means that the pushrod or lock shaft sticking and, in such a case, remove the tensioner and service the pushrod and lock shaft to make them move smoothly.

CAUTION:

After installing the tensioner and checking it in initially set condition for operation, do not attempt to turn the handle in either direction until the next overhaul.

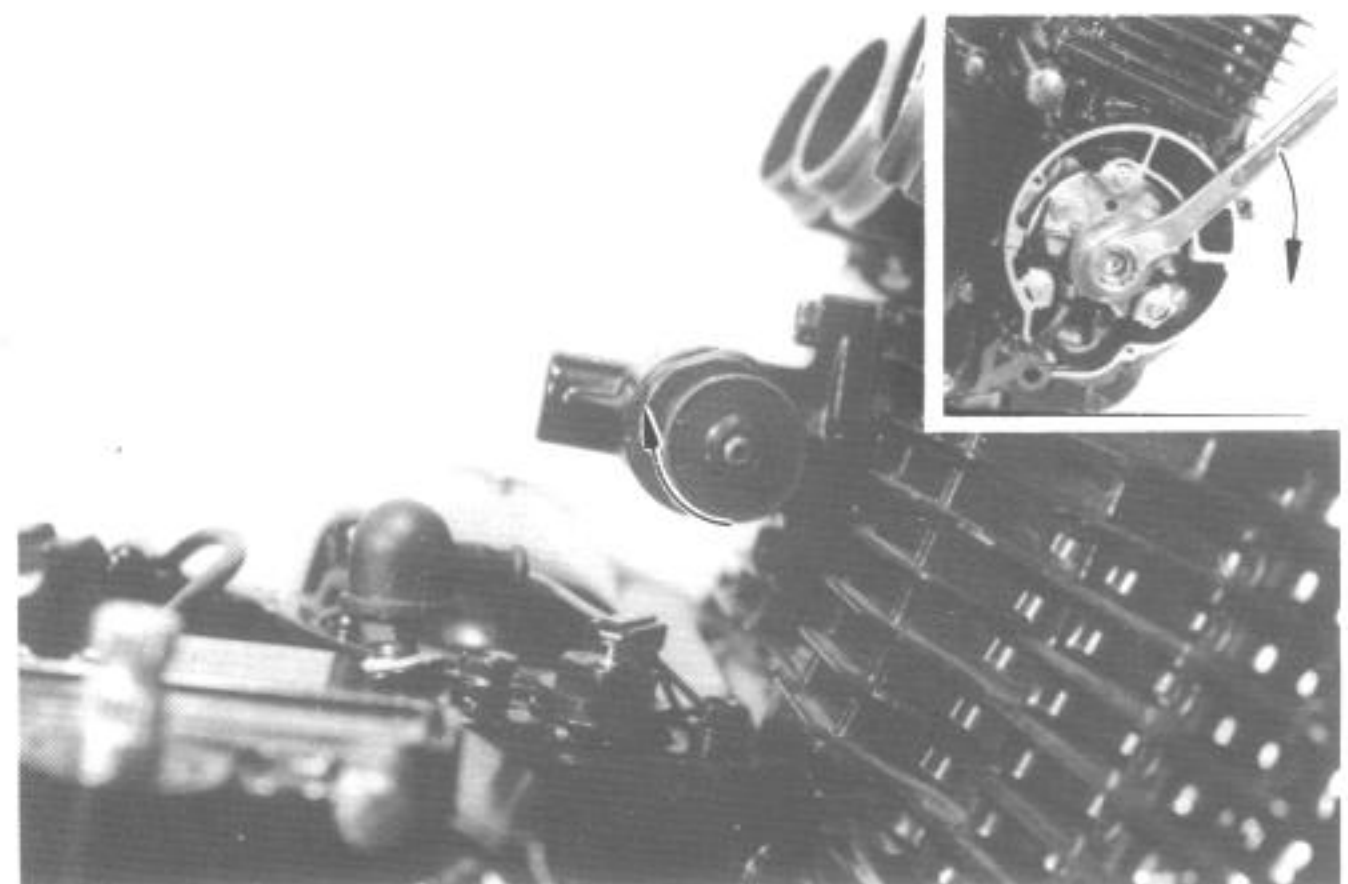

- Adjust the valve clearance. (see page 2-6)
- In fitting the seal ring to the oil filter chamber cap, lightly coat grease on the seal ring groove ① to avoid any chance of dropping or mislocating the ring during the installation work.
- Make sure that the oil passage ② is not clogged.
- Apply thread lock cement to filter cap nuts.

99000-32040

Thread lock cement

- Tighten engine oil drain plug.
- Pour 50 ml of engine oil in eight oil pockets in the head.

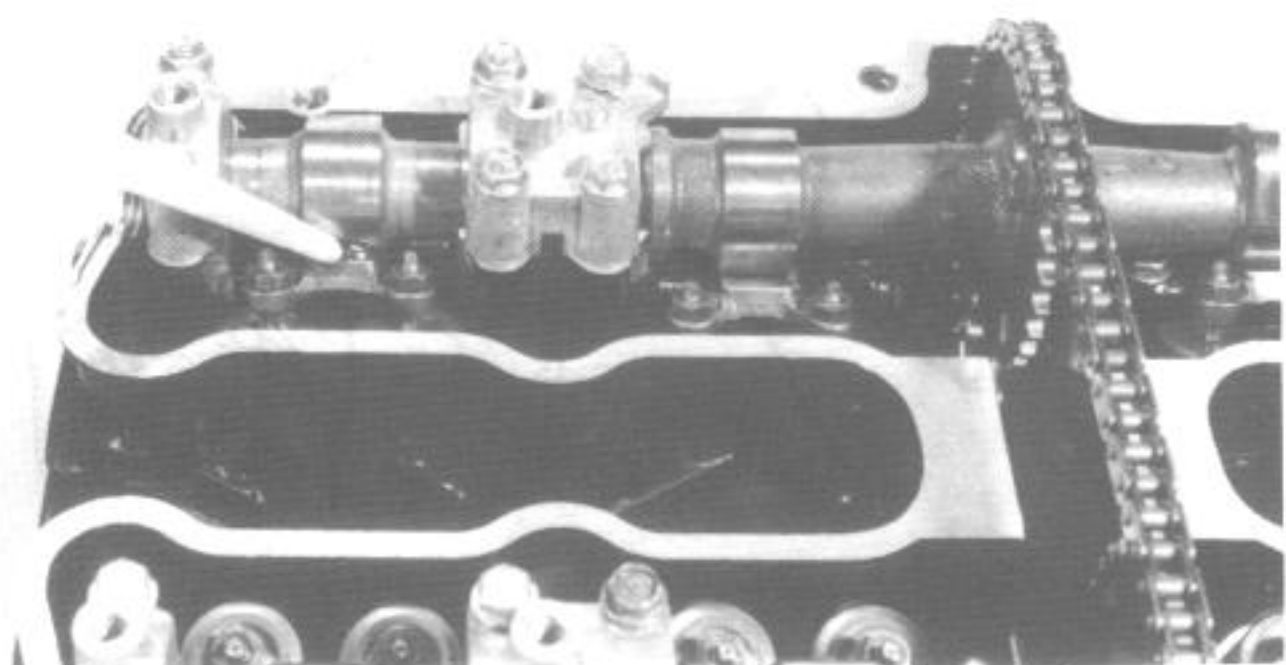
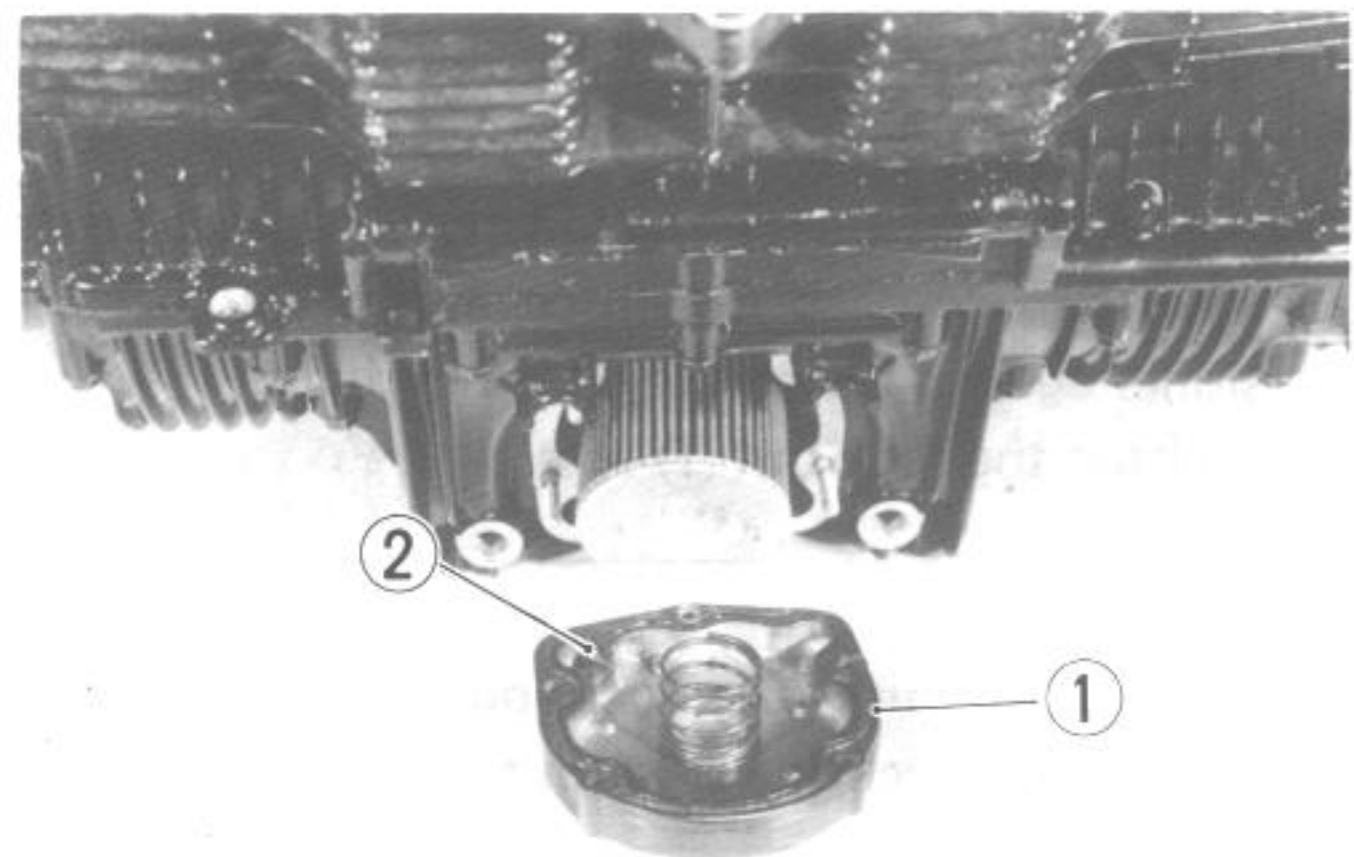

- Before installing the cylinder head cover gasket on the cylinder head cover, apply SUZUKI Bond No. 1207B to the head cover groove.

99000-31140	SUZUKI Bond No. 1207B
-------------	-----------------------

NOTE:

Inspect the gasket for cracks, nicks or tears. If any damage is found, the gasket should be replaced.

- Place the gasket into the locating groove and push the gasket into place.
- Apply SUZUKI Bond No. 1207B to the four end cam caps of gasket as shown.

99000-31140	SUZUKI Bond No. 1207B
-------------	-----------------------

- Install the cylinder head cover.
- Oil each head cover bolt washers lightly.
- Tighten the head cover bolts to the specifications.

Tightening torque	Initial	10 N·m (1.0 kg-m)
	Final	13 – 15 N·m (1.3 – 1.5 kg-m)

- Each cylinder head intake pipe is identified with a letter "R" or "L" on it. Fit each pipe to cylinder head properly.

CAUTION:

"MADE IN JAPAN" mark on the intake pipe faces to the cylinder head side.

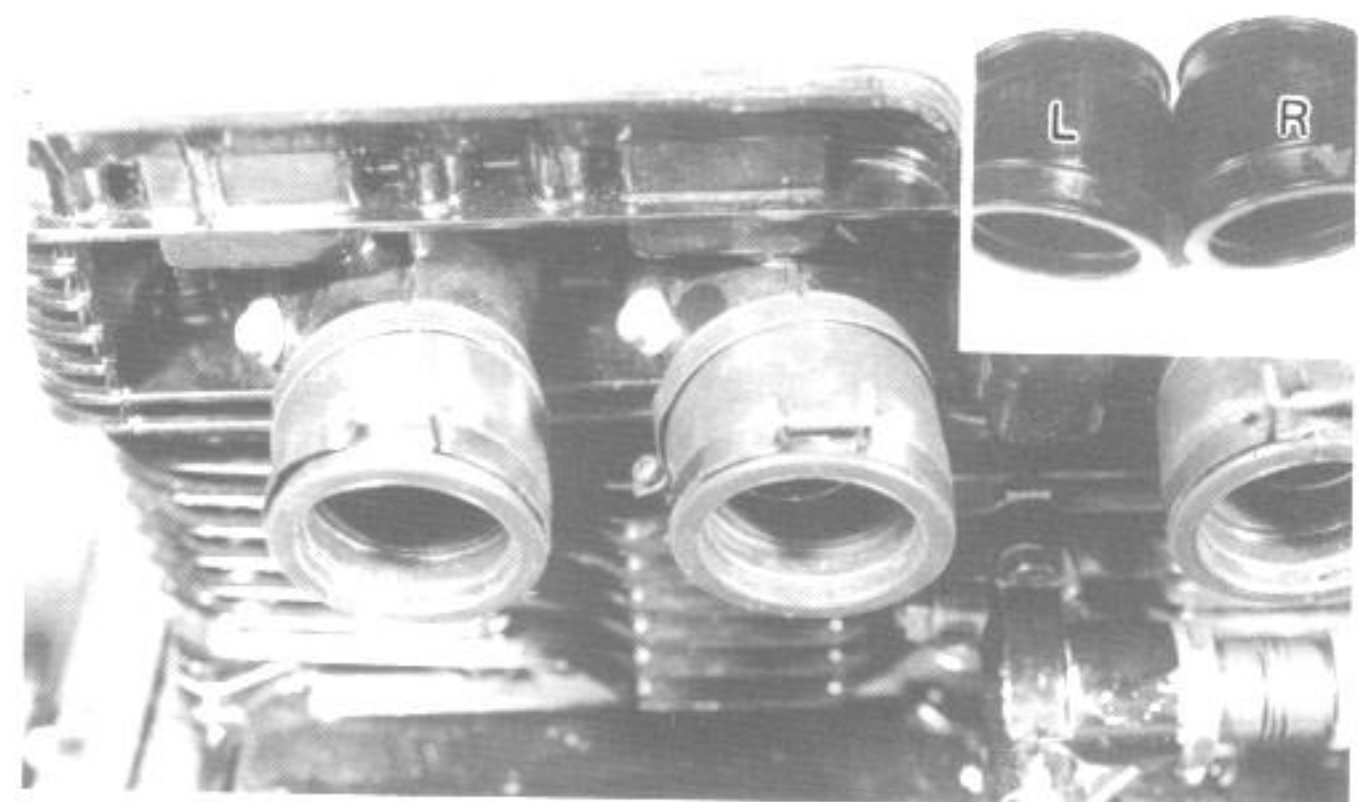
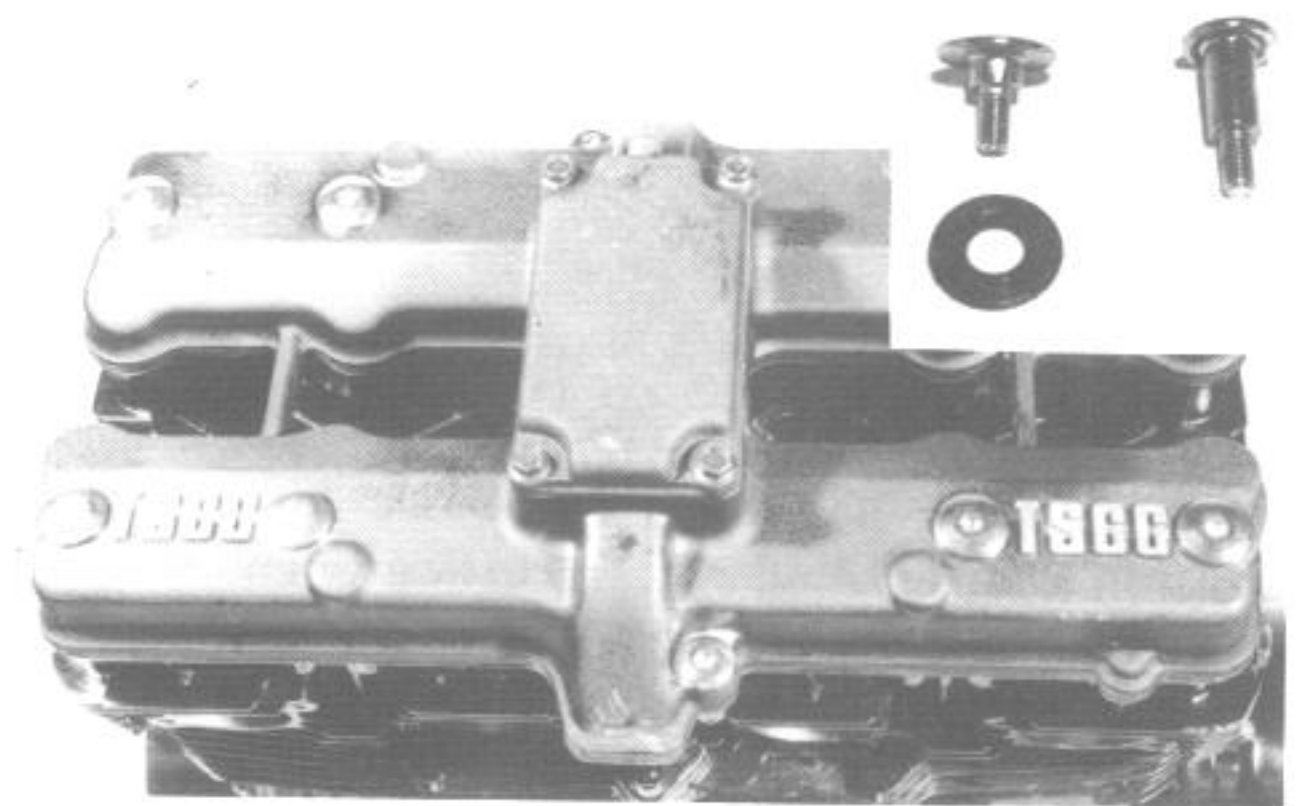
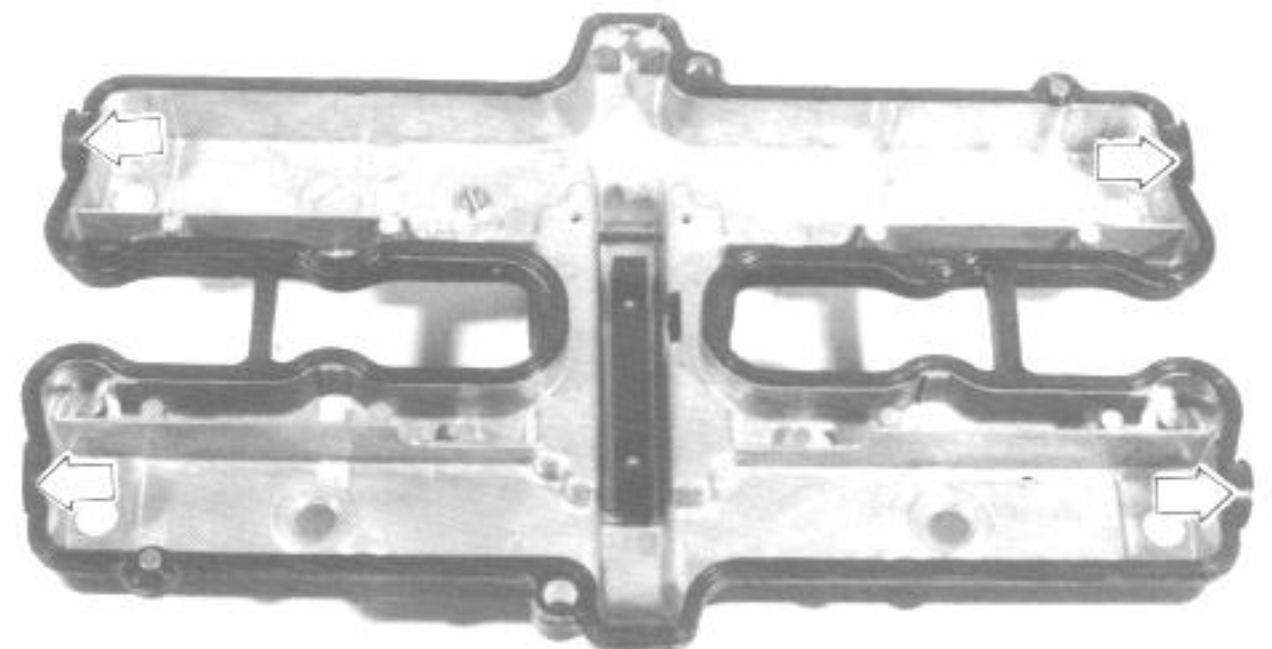
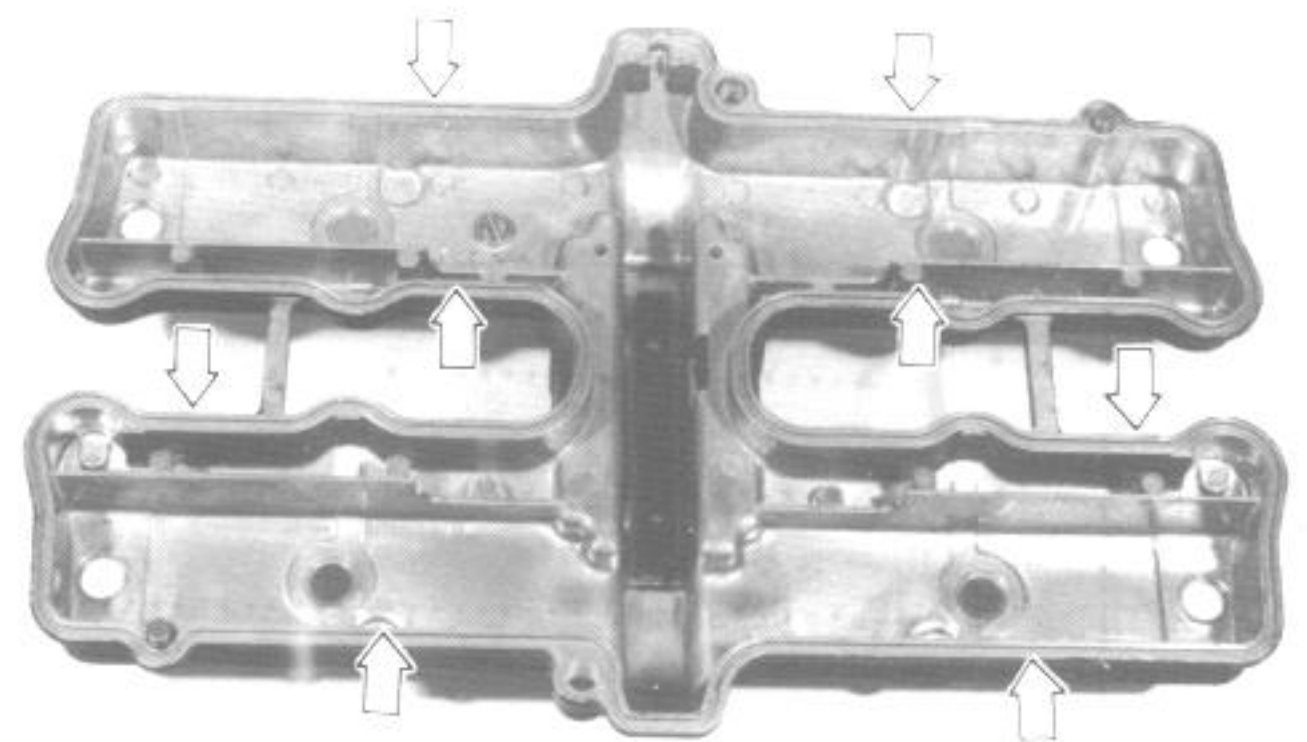

FUEL AND LUBRICATION SYSTEM

CONTENTS

FUEL COCK.....	4- 1
CARBURETOR.....	4- 2
LUBRICATION SYSTEM.....	4-15

FUEL COCK

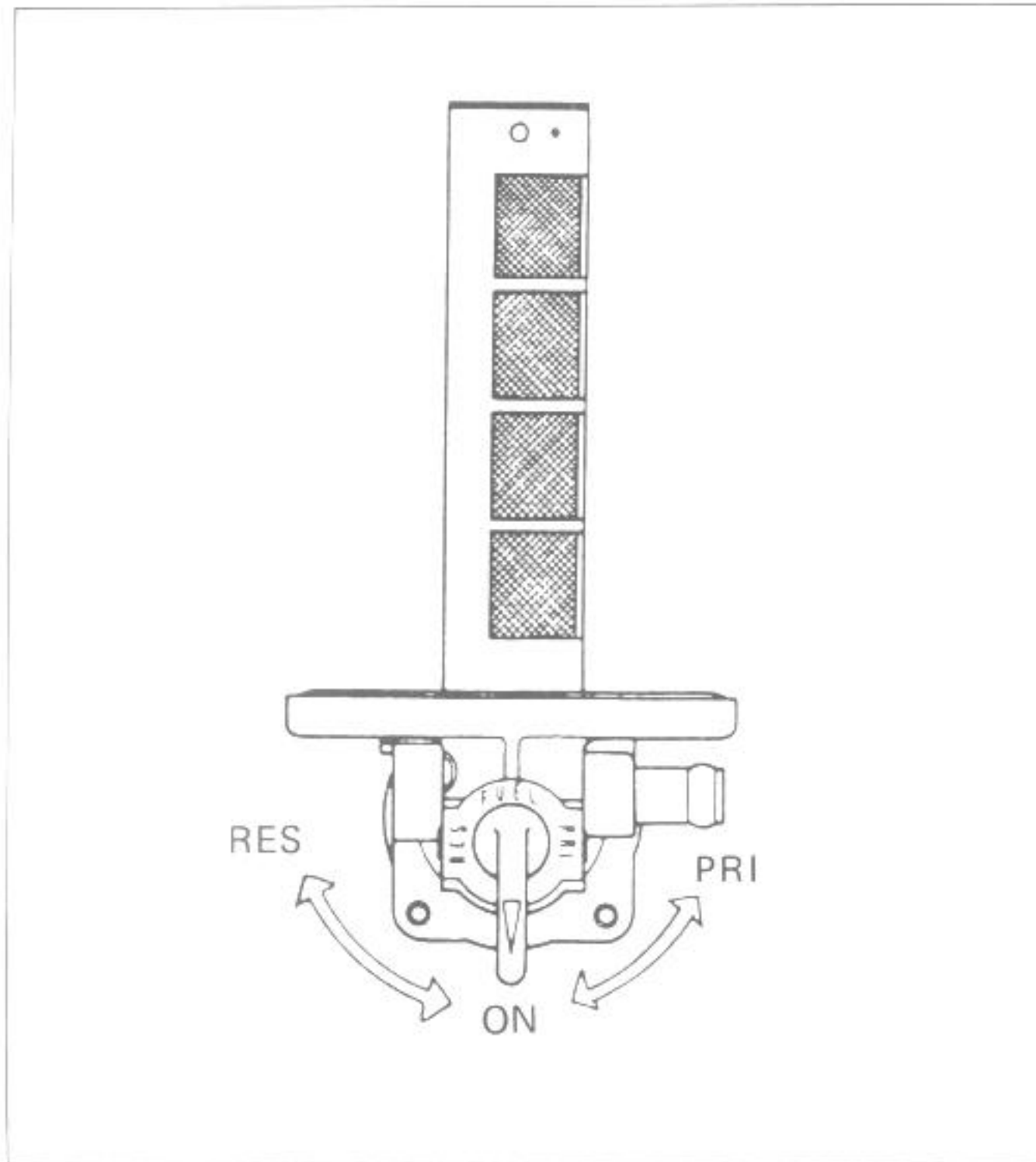

When the engine is not running and the valve in the ON position, the fuel valve is kept in the closed position by applying pressure utilizing a spring so that no fuel will flow to the carburetors.

When the engine is engaged, a negative pressure is generated in the diaphragm chamber "C" through the vacuum (negative pressure) pipe which is connected to the carburetors, and builds up a negative pressure which is higher than the spring pressure so that the diaphragm is forced to open the fuel valve and thus allow the fuel to flow to the carburetors.

On the other hand, setting the valve in the ON position keeps the air return orifice open.

Negative pressure does not accumulate on the diaphragm at the time of engine stopping, and then the spring pressure actuates the diaphragm to move back to its original position and closes the fuel valve.

When the lever is set to PRI position, the protrusion ⑥ located on the lever end pushes back the fuel valve mechanically against the spring force and it allows fuel to flow to the carburetors directly, whether the engine is running or not, through the RES side fuel filter and fuel valve clearance.

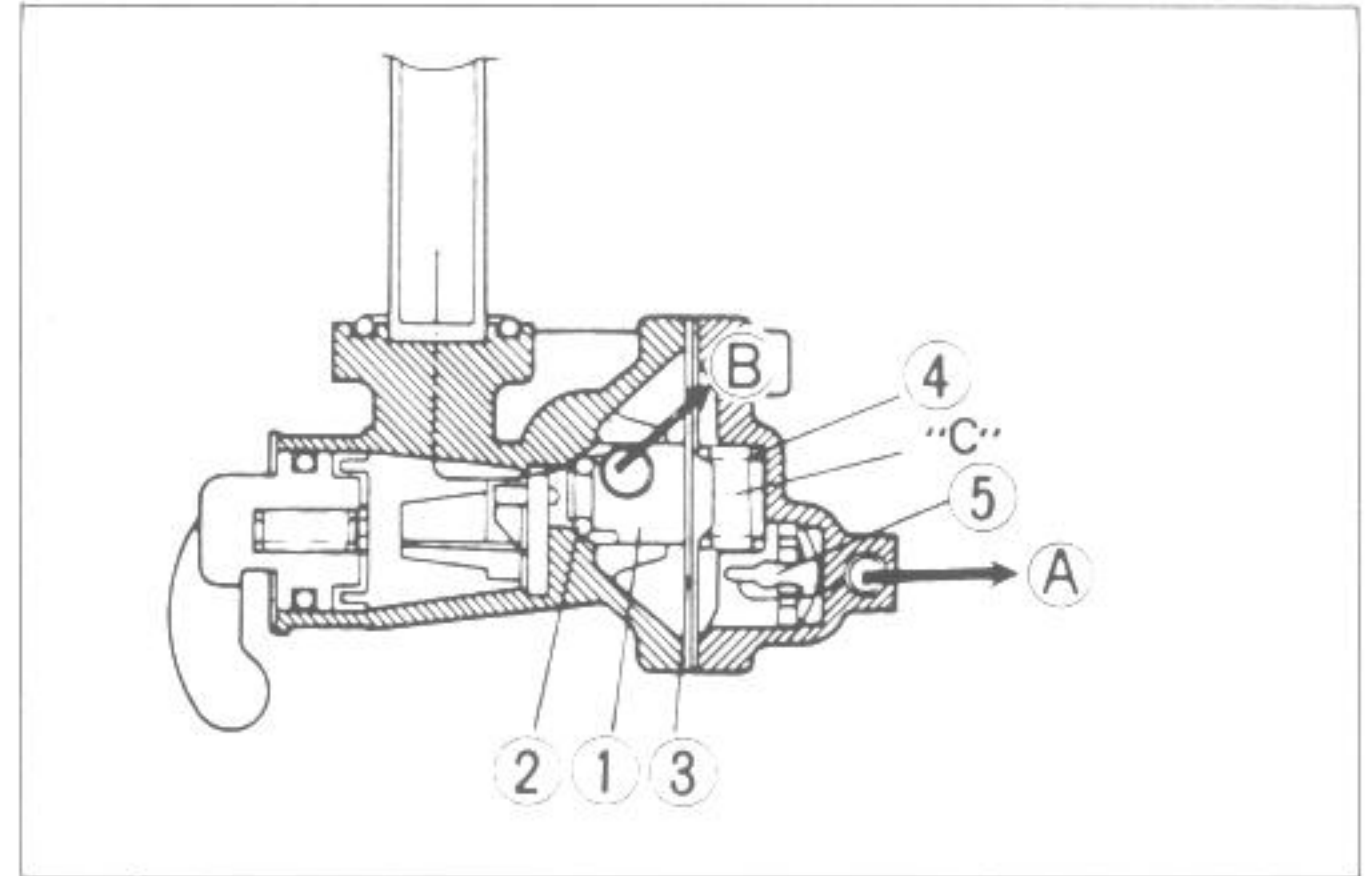

"ON"

- | | | |
|--------------|-----------------|---------------------|
| ① Fuel valve | ② O-ring | ③ Diaphragm |
| ④ Spring | ⑤ One way valve | ⑥ Cam |
| Ⓐ Vacuum | Ⓑ Fuel flow | Ⓒ Diaphragm chamber |

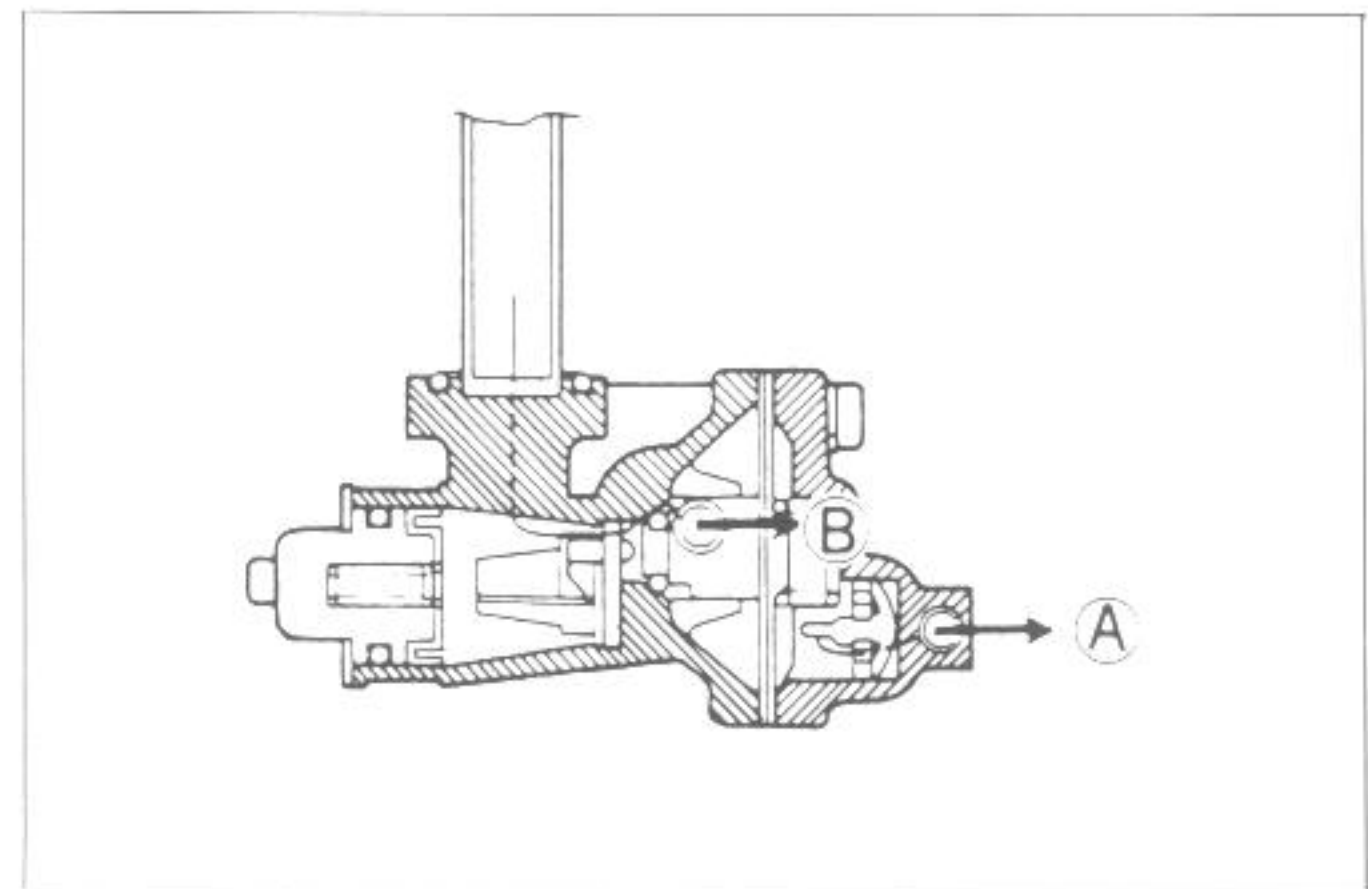

"RES"

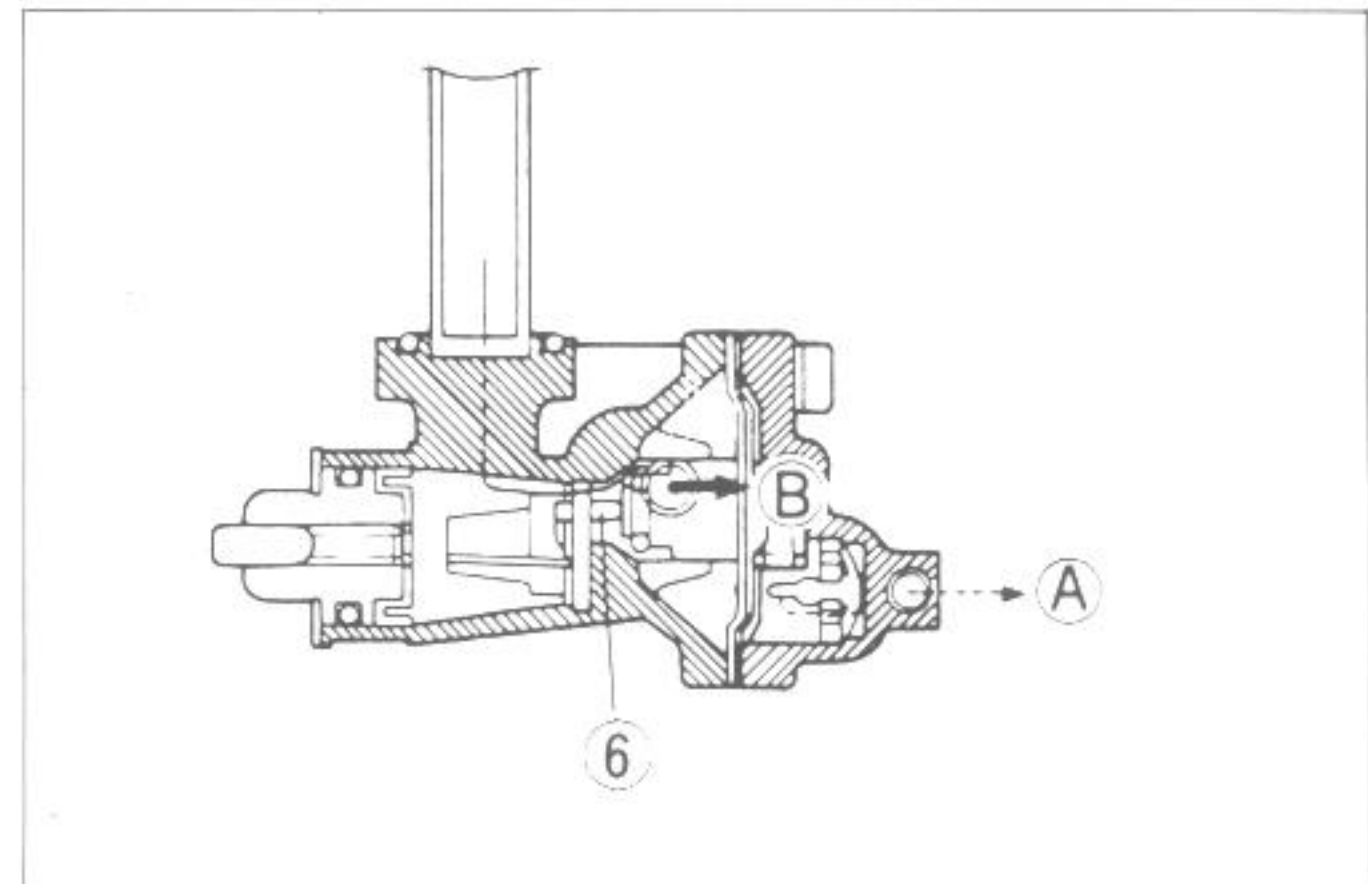

"PRI"

CARBURETOR

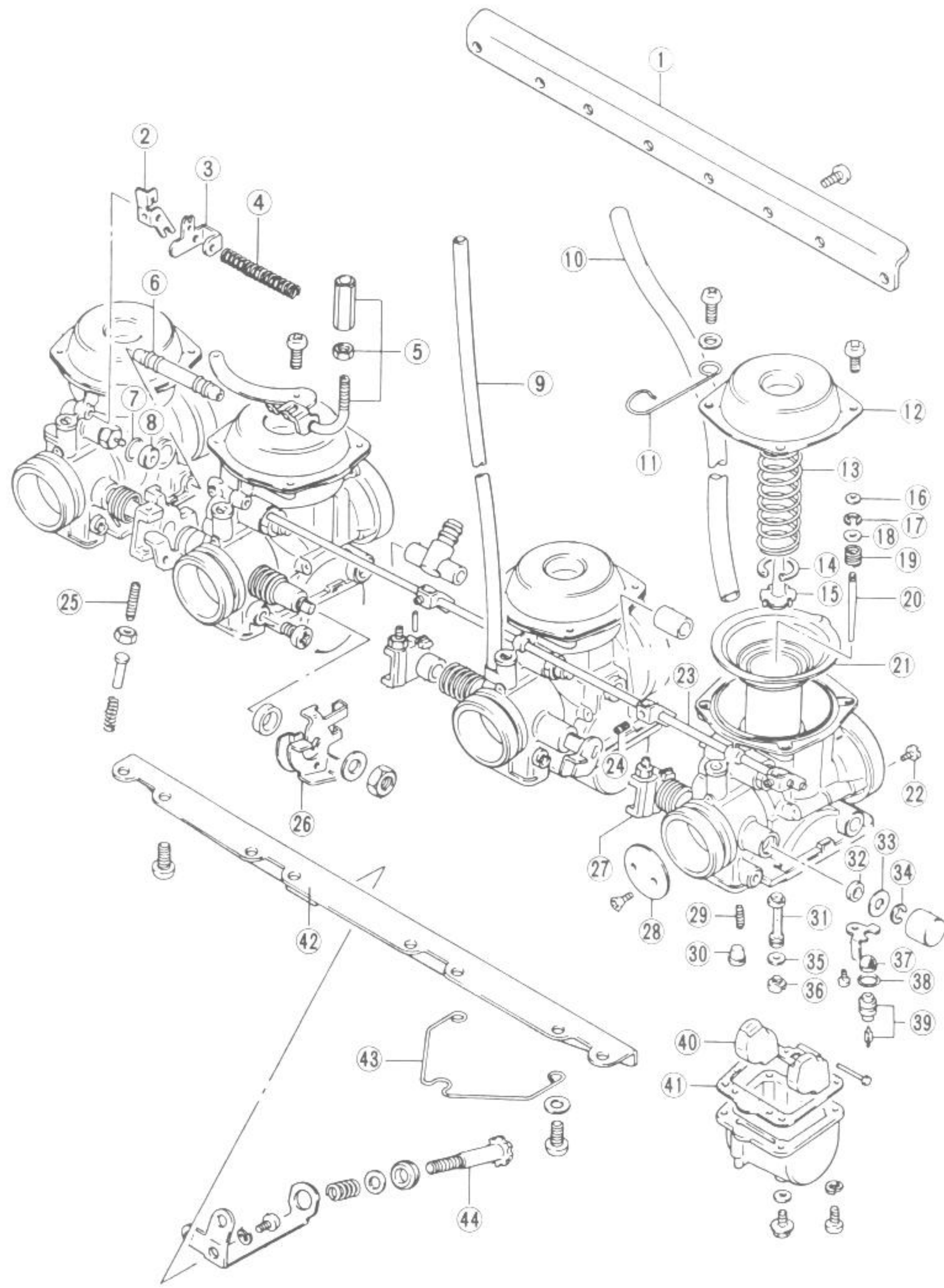

- | | | | |
|------------------------------|------------------------|----------------------------|----------------------|
| ① Guide plate | ⑫ Carburetor top cap | ⑳ Starter shaft | ⑳ E-ring |
| ② Starter lever | ⑬ Spring | ㉑ Starter shaft lock screw | ㉑ Washer |
| ③ Starter cable lock lever | ⑭ Circlip | ㉒ Carburetor balance screw | ㉒ Main jet |
| ④ Starter shaft spring | ⑮ Jet needle stopper | ㉓ Throttle lever | ㉓ Fuel filter |
| ⑤ Starter cable guide | ⑯ Spacer | ㉔ Throttle valve shaft | ㉔ O-ring |
| ⑥ Fuel connector pipe | ⑰ Clip | ㉕ Throttle valve | ㉕ Needle valve |
| ⑦ O-ring | ⑱ Washer | ㉖ Pilot screw | ㉖ Float |
| ⑧ Dust seal | ⑲ Spring | ㉗ Rubber plug | ㉗ Gasket |
| ⑨ Fuel cock vacuum pipe | ㉑ Jet needle | ㉘ Needle jet | ㉘ Guide plate |
| ⑩ Fuel chamber breather pipe | ㉒ Diaphragm and piston | ㉙ Oil seal | ㉙ Clutch cable guide |
| ⑪ Clutch cable guide | ㉓ Pilot air jet | ㉚ Washer | ㉚ Idle adjust screw |

SPECIFICATIONS

ITEM	SPECIFICATIONS	
	E1, 6, 24, 28	The others
Type	MIKUNI BS36SS	←
I.D. No.	00A30	00A00
Bore	36 mm	←
Idle r/min	1100 ± 50 r/min	←
Fuel level	3.0 ± 0.5 mm	←
Float height	21.4 ± 1.0 mm	←
Main jet	#120	←
Main air jet	1.2 mm	←
Jet needle	5D59-2nd	←
Needle jet	X-5	←
Pilot jet	#47.5	←
By pass	0.9, 0.8, 0.9 mm	←
Pilot outlet	0.9 mm	←
Valve seat	2.0 mm	←
Starter jet	#32.5	←
Pilot screw	PRE-SET (2 turns back)	←
Throttle valve	#130	←
Pilot air jet	#125	←
Throttle cable play	2 – 3 mm	←
Choke cable play	0.5 – 1.0 mm	←

I.D. NO. LOCATION

Each carburetor has I.D. Number ① printed on the carburetor body according to its specifications.

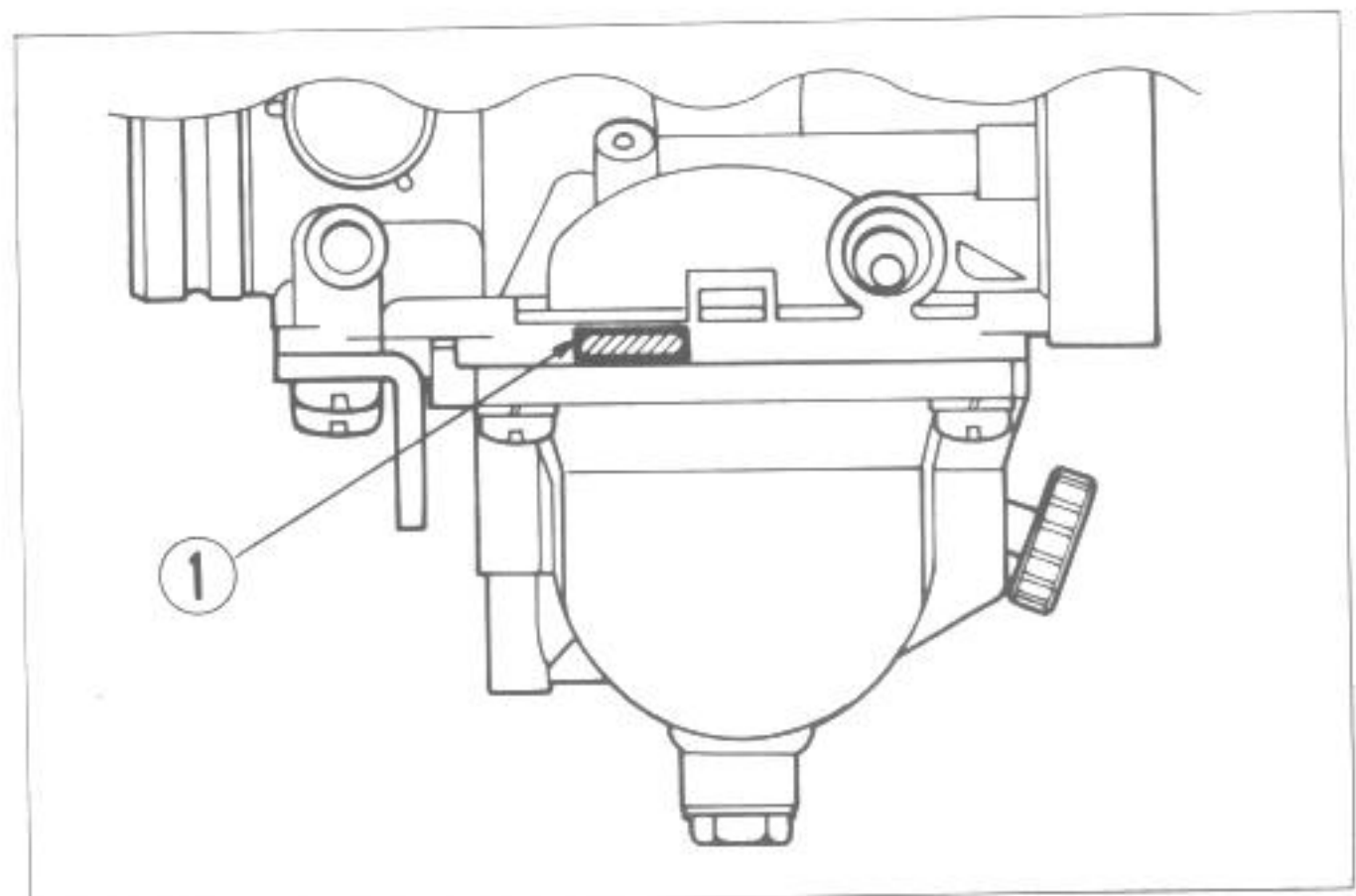

DIAPHRAGM AND PISTON OPERATION

The carburetor is of a variable-venturi type, whose venturi cross section area is increased or decreased automatically by the piston according to the vacuum present on the downstream side of the venturi. Vacuum is admitted into the diaphragm chamber through an orifice provided in the piston.

Rising vacuum overcomes the spring force, causing the piston to rise to increase the said area and thus prevent the air velocity from increasing. Thus, air velocity in the venturi passage is kept relatively constant for improved fuel atomization and for securing an optimum ratio of fuel to air in the mixture.

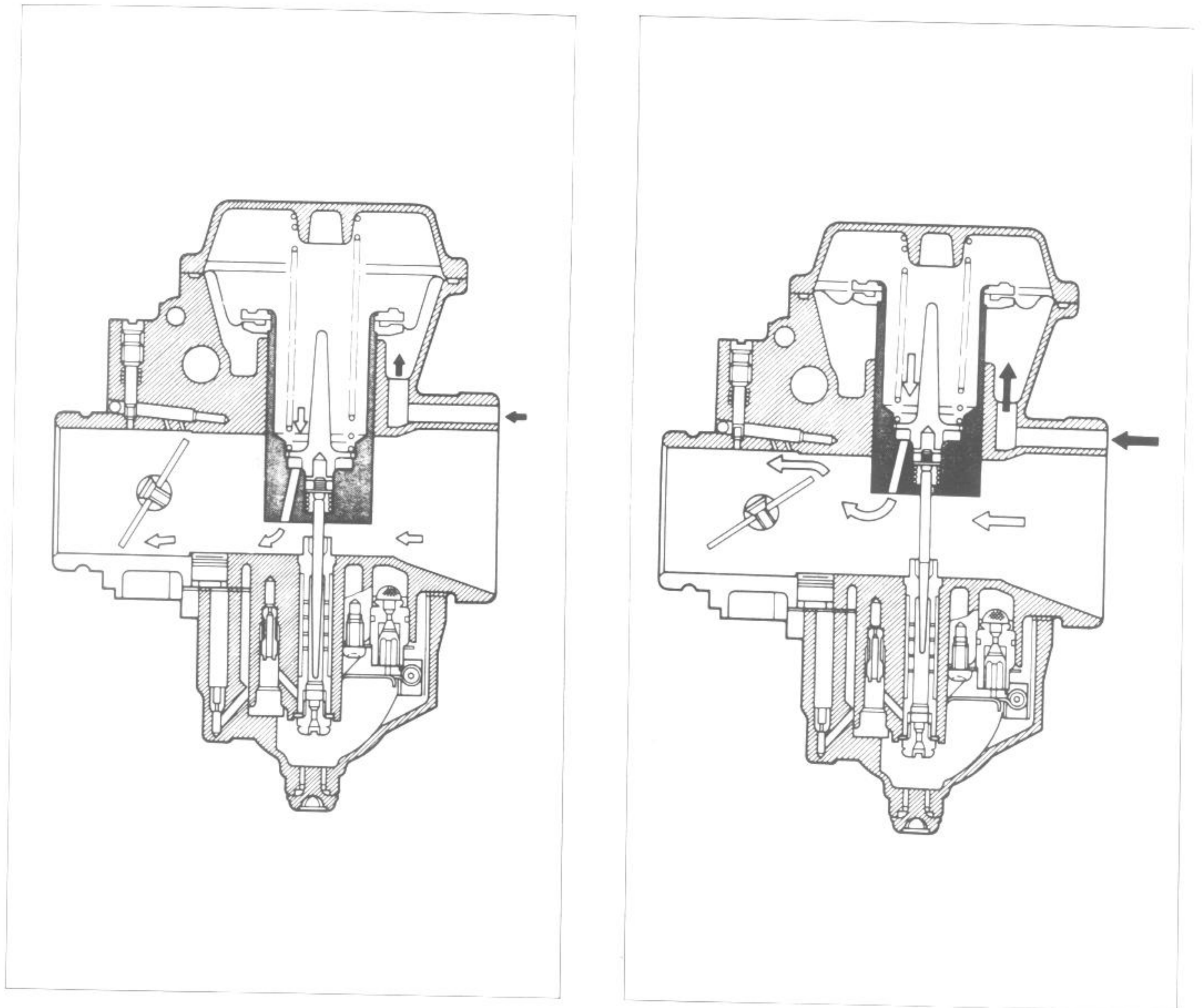

SLOW SYSTEM

This system supplies fuel during engine operation with throttle valve closed or slight opened.

The fuel from float chamber is first passed through main jet and metered by pilot jet where it mixes with air coming in through pilot air jet.

This mixture, rich with fuel, then goes up through pilot pipe to pilot screw. A part of the mixture is discharged into the main bore out of bypass ports. The remainder is then metered by pilot screw and sprayed out into the main bore through pilot outlet.

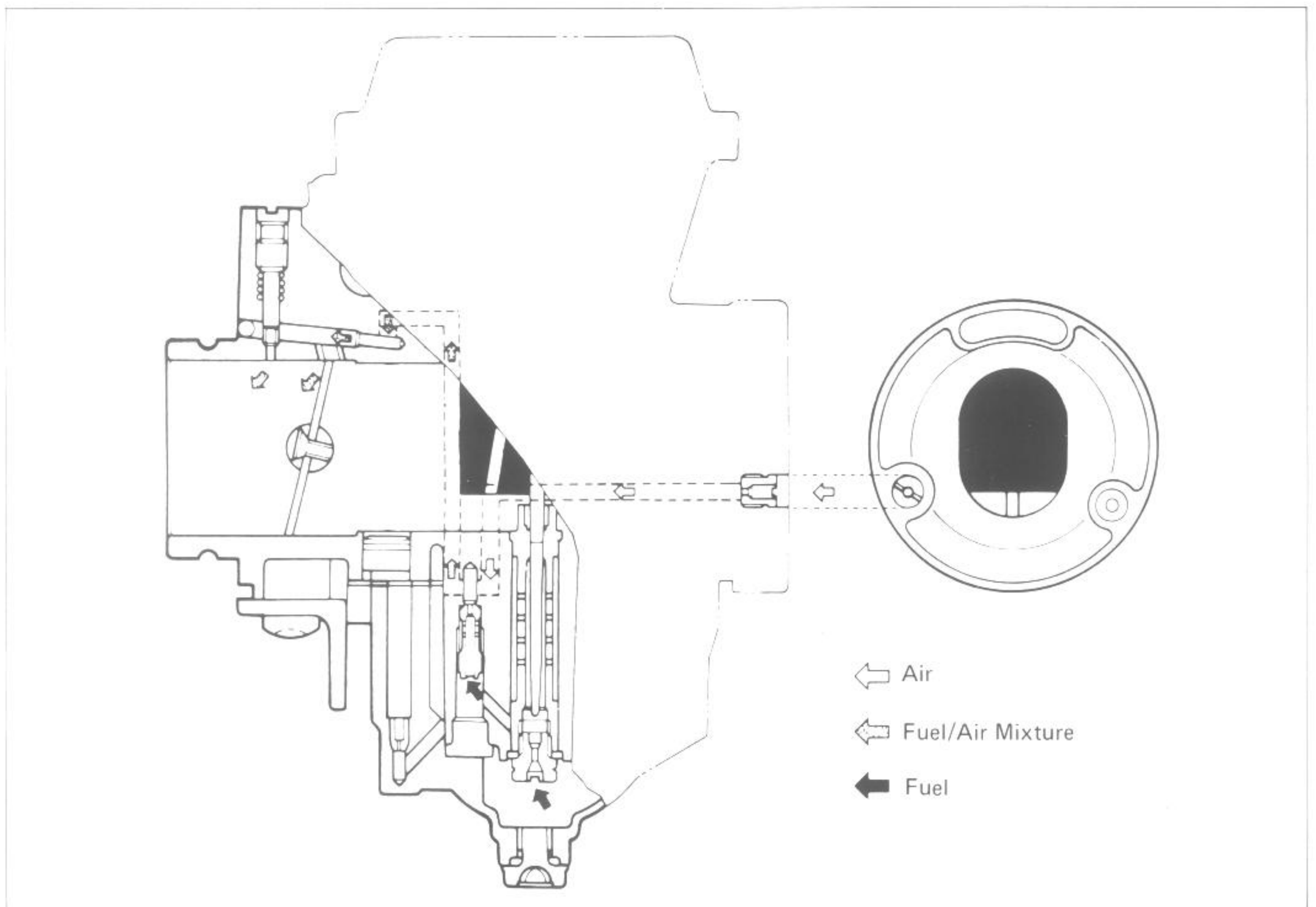

MAIN SYSTEM

As throttle valve is opened, engine speed rises, and this increases vacuum in the venturi. Consequently the piston valve moves upward.

Meanwhile, the fuel in float chamber is metered by main jet, and the metered fuel enters needle jet, in which it mixes with the air admitted through main air jet to form an emulsion.

The emulsified fuel then passes through the clearance between needle jet and jet needle, and is discharged into the venturi, in which it meets main air stream being drawn by the engine.

Mixture proportioning is accomplished in needle jet; the clearance through which the emulsified fuel must flow is large or small, depending ultimately on throttle position.

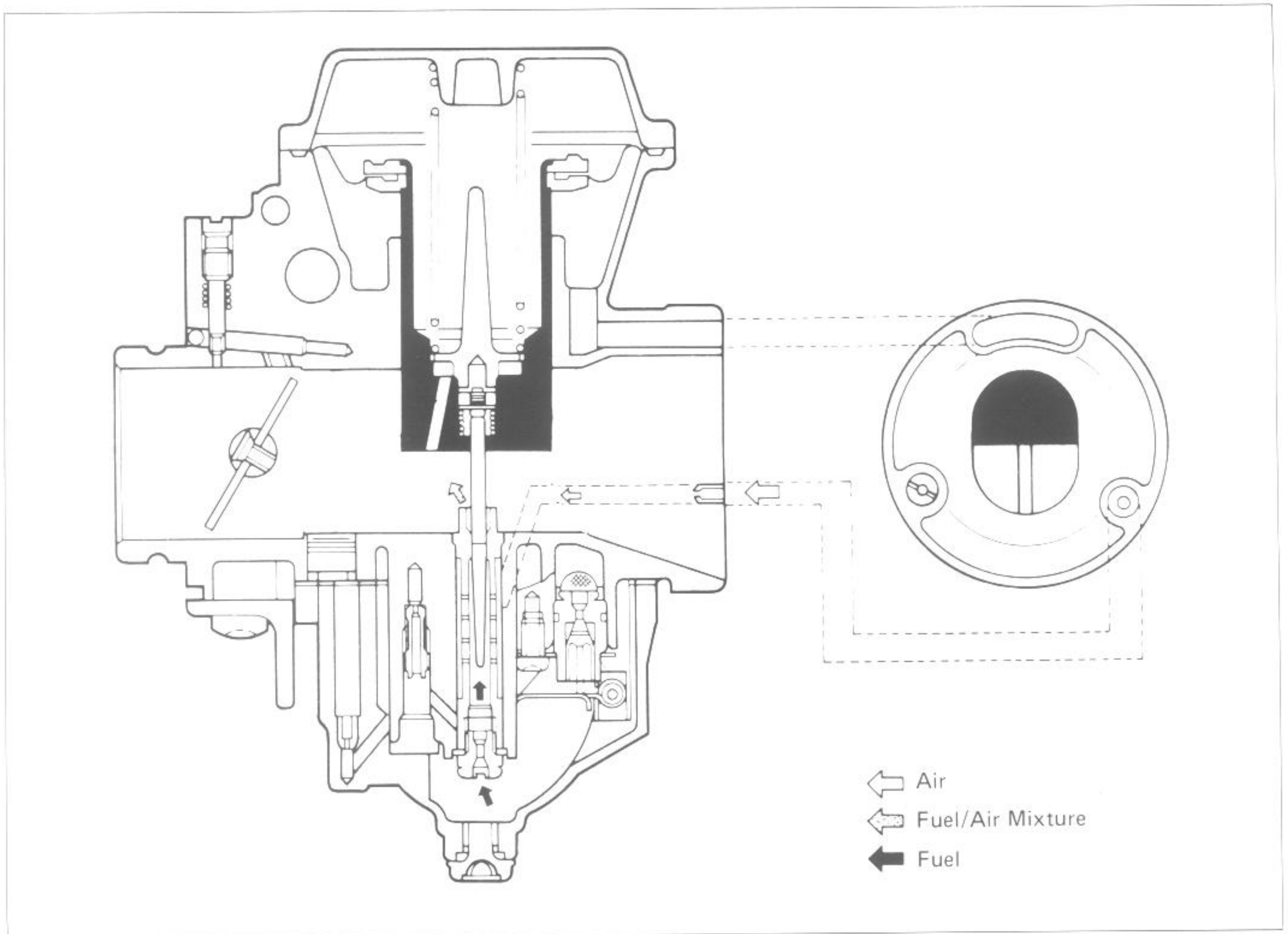

STARTER SYSTEM

Pulling up the starter knob draws fuel into the starter circuit from the float chamber.

Starter jet meters this fuel, which then flows into starter pipe and mixes with the air coming from the float chamber. The mixture, rich in fuel content, reaches starting plunger and mixes again with the air coming through a passage extending from behind the diaphragm.

The two successive mixings of fuel with air are such that proper fuel/air mixture for starting is produced when the mixture is sprayed out through starter outlet into the main bore.

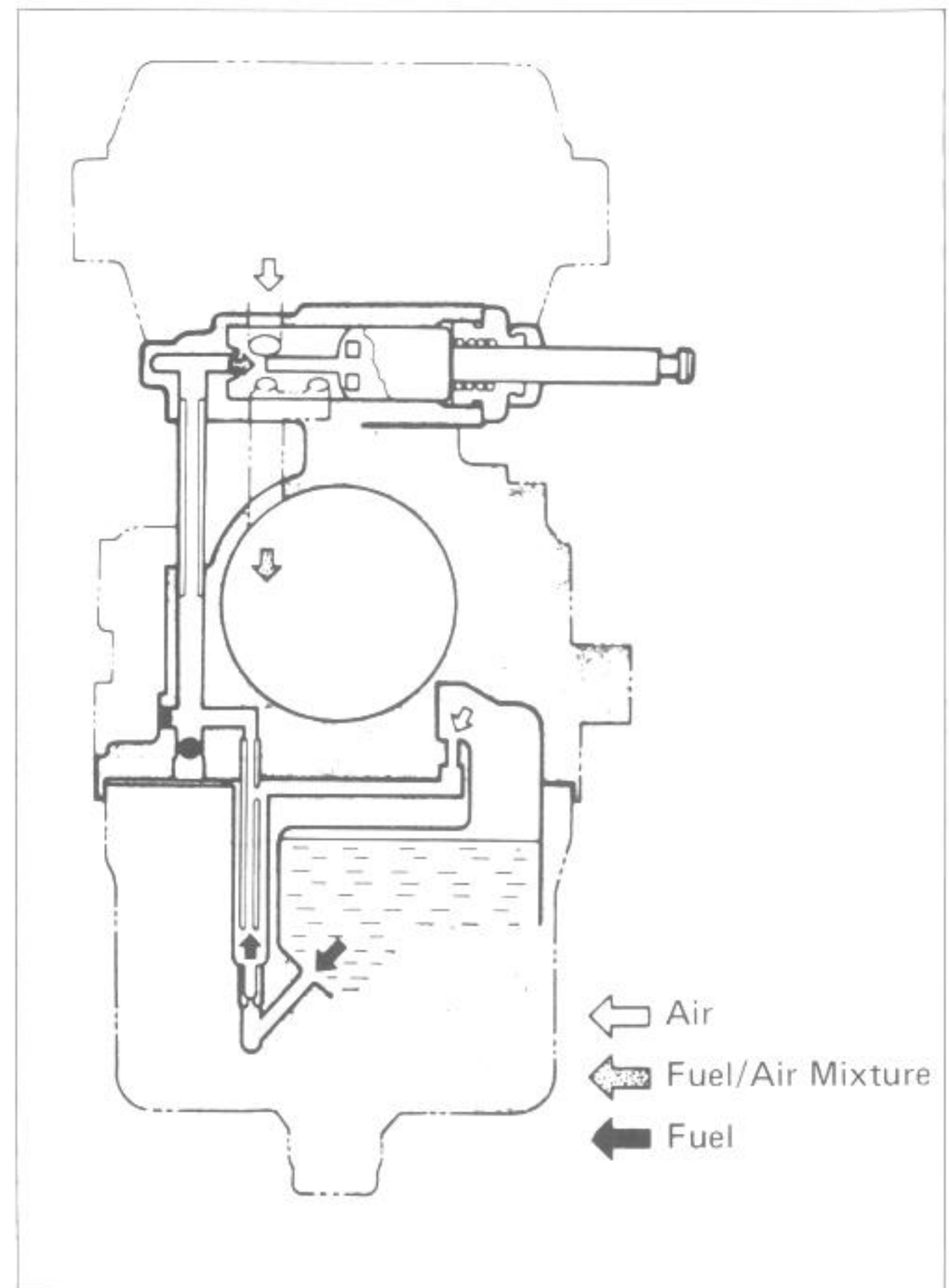

FLOAT SYSTEM

Floats and needle valve are associated with the same mechanism, so that, as the floats move up and down, the needle valve too moves likewise. When fuel level is up in float chamber, floats are up and needle valve remains pushed up against valve seat. Under this condition, no fuel enters the float chamber.

As the fuel level falls, floats go down and needle valve unseats itself to admit fuel into the chamber. In this manner, needle valve admits and shuts off fuel alternately to maintain a practically constant fuel level inside the float chamber.

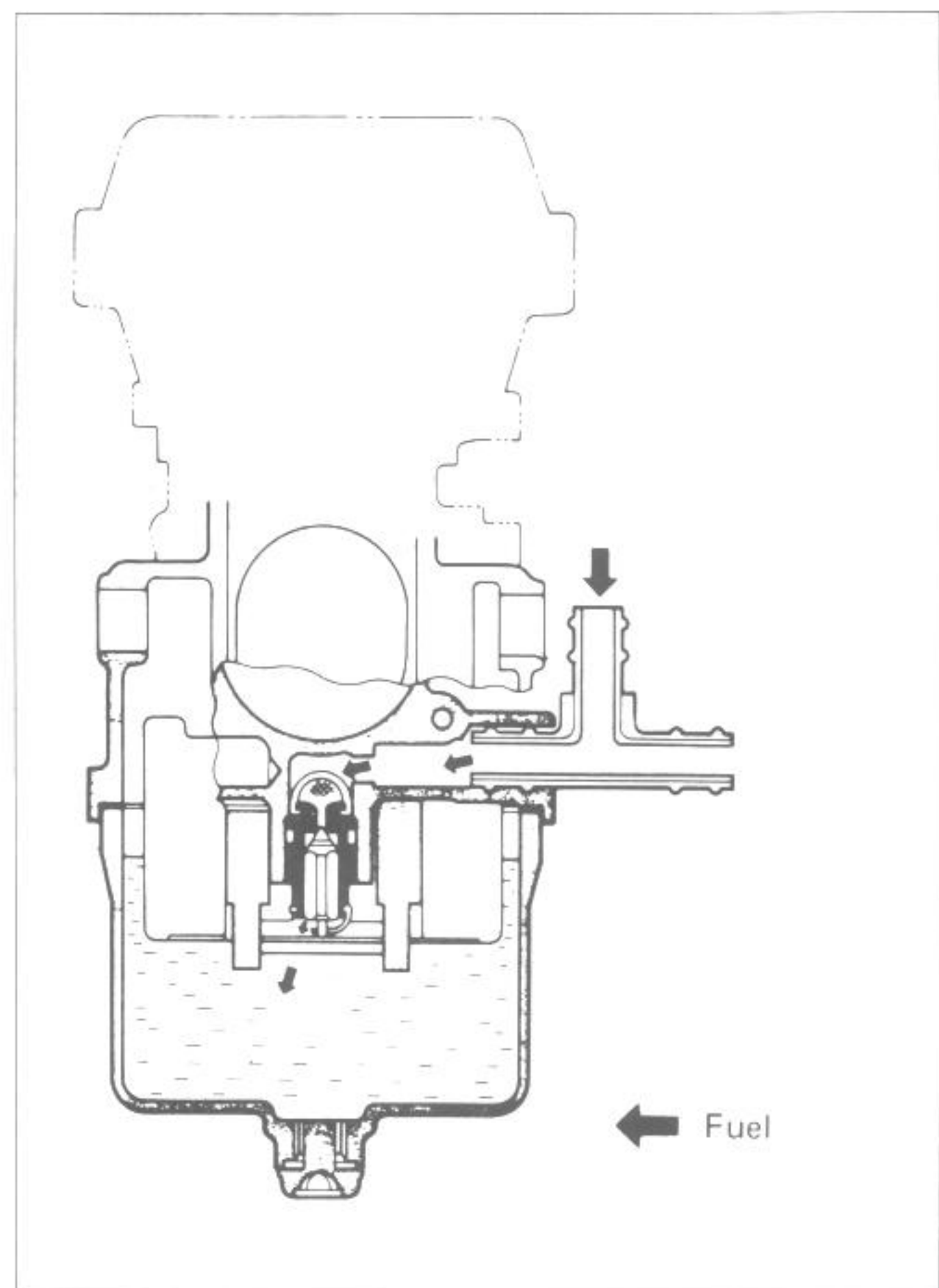

FUEL SYSTEM

When turning starter motor, negative pressure is generated in the combustion chamber. This negative pressure works on the diaphragm of fuel cock through passageway provided in the carburetor main bore and vacuum pipe, and diaphragm builds up a negative pressure which is higher than the spring pressure. Fuel valve is forced to open due to diaphragm operation, and thus allow fuel to flow into carburetor float chamber.

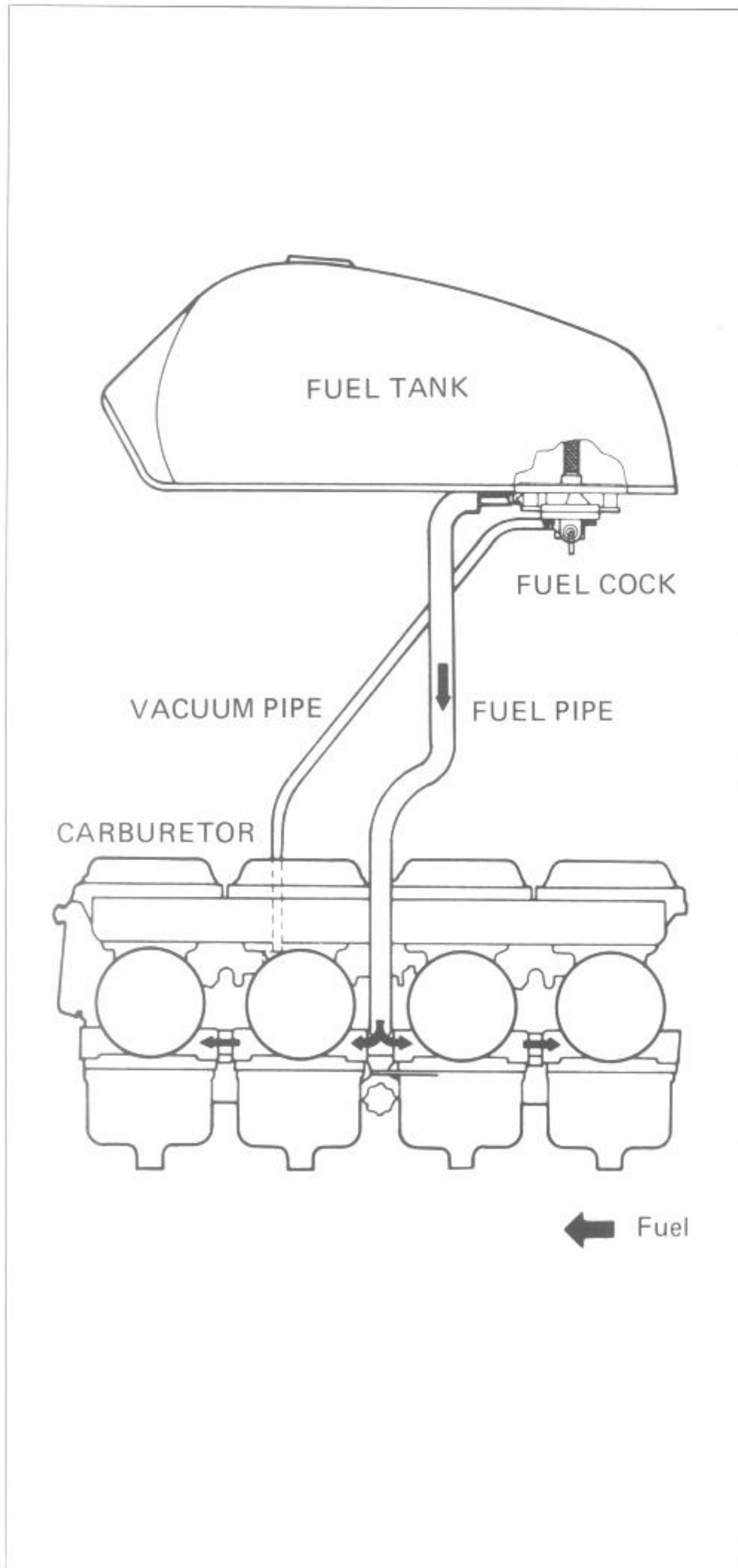

DISASSEMBLY

- Loosen 4 tightening screws ① of starter shaft and pull out starter shaft to the right.

CAUTION:

These four screws are locked with thread lock. Once removing screws, they will be damaged.

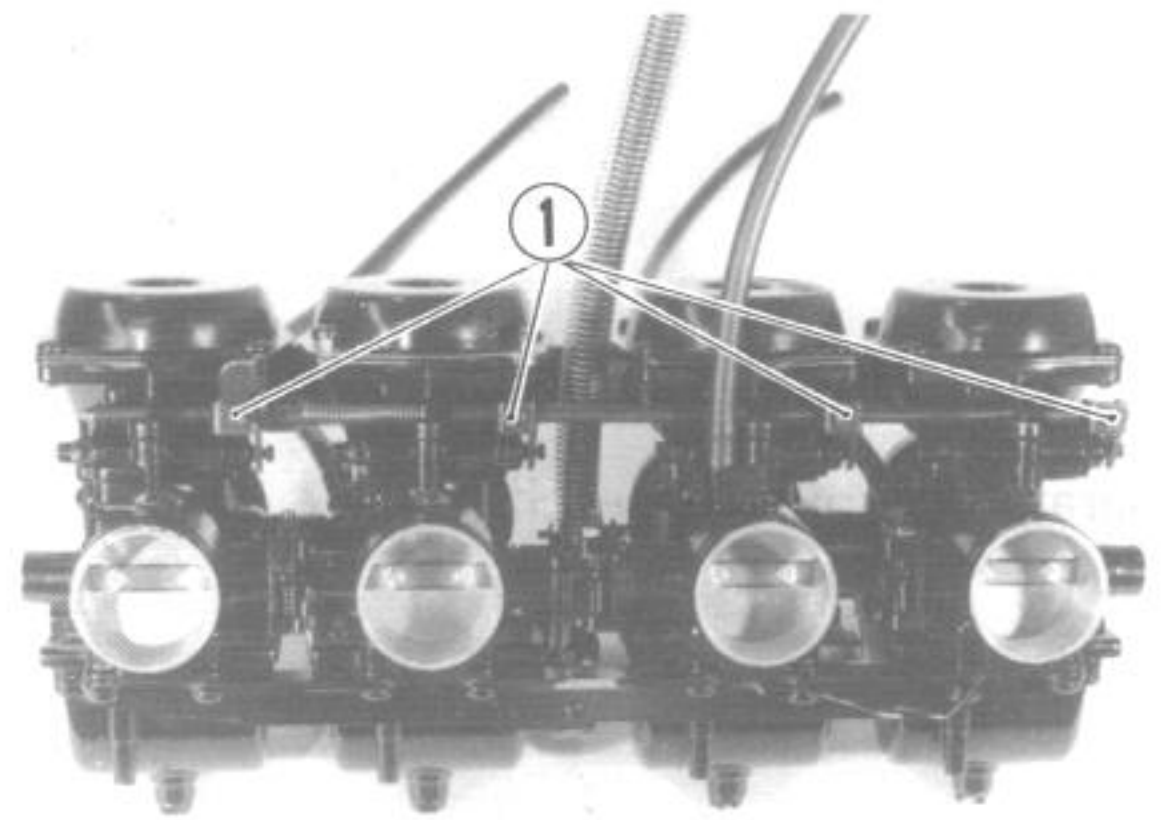

- Remove carburetor set upper plate ② by unscrewing 8 screws.

09900-09003	Impact driver set
-------------	-------------------

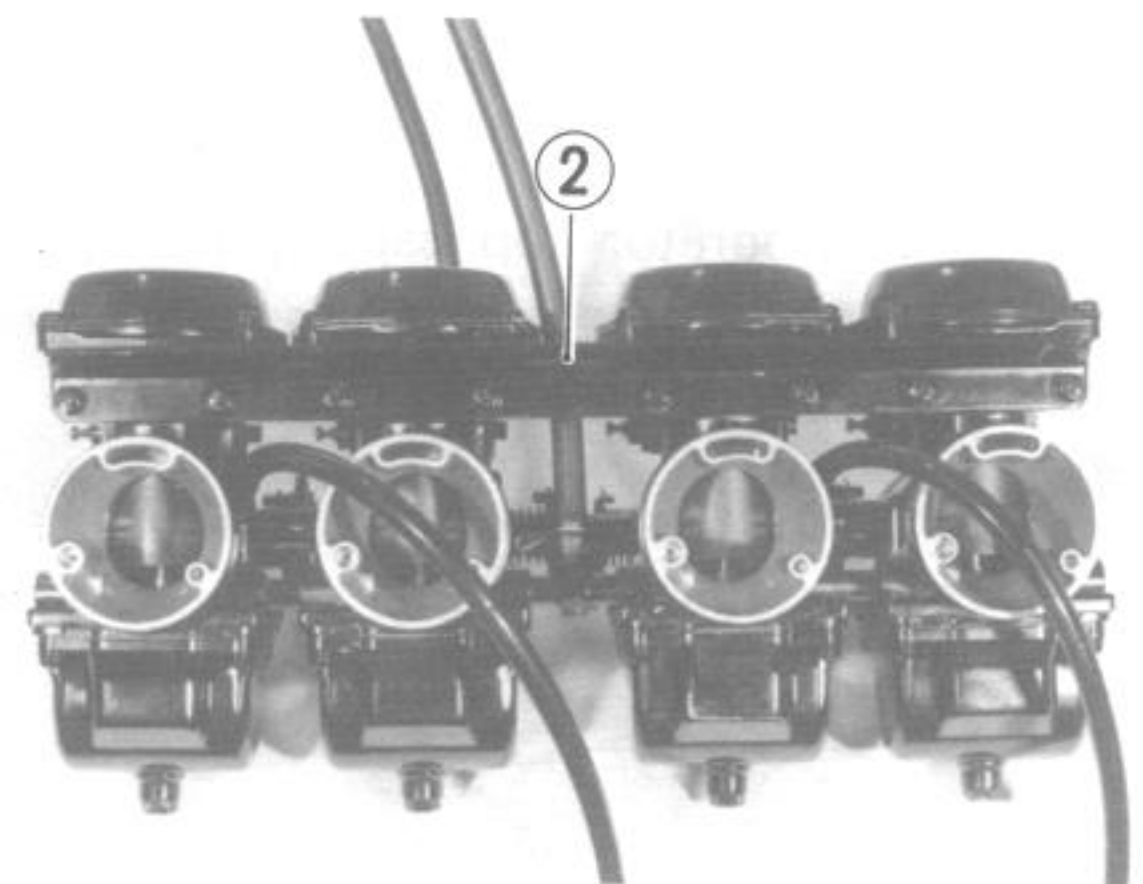

- Remove carburetor set lower plate ① by unscrewing 8 screws.

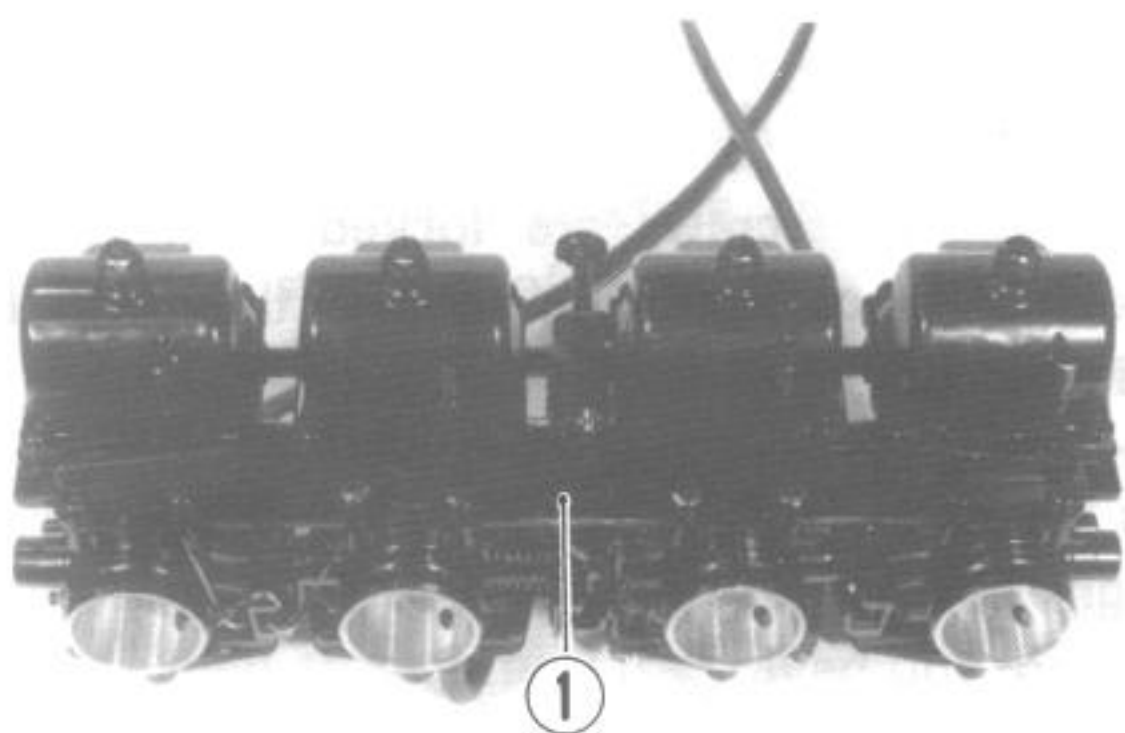

- Separate 4 carburetors each.

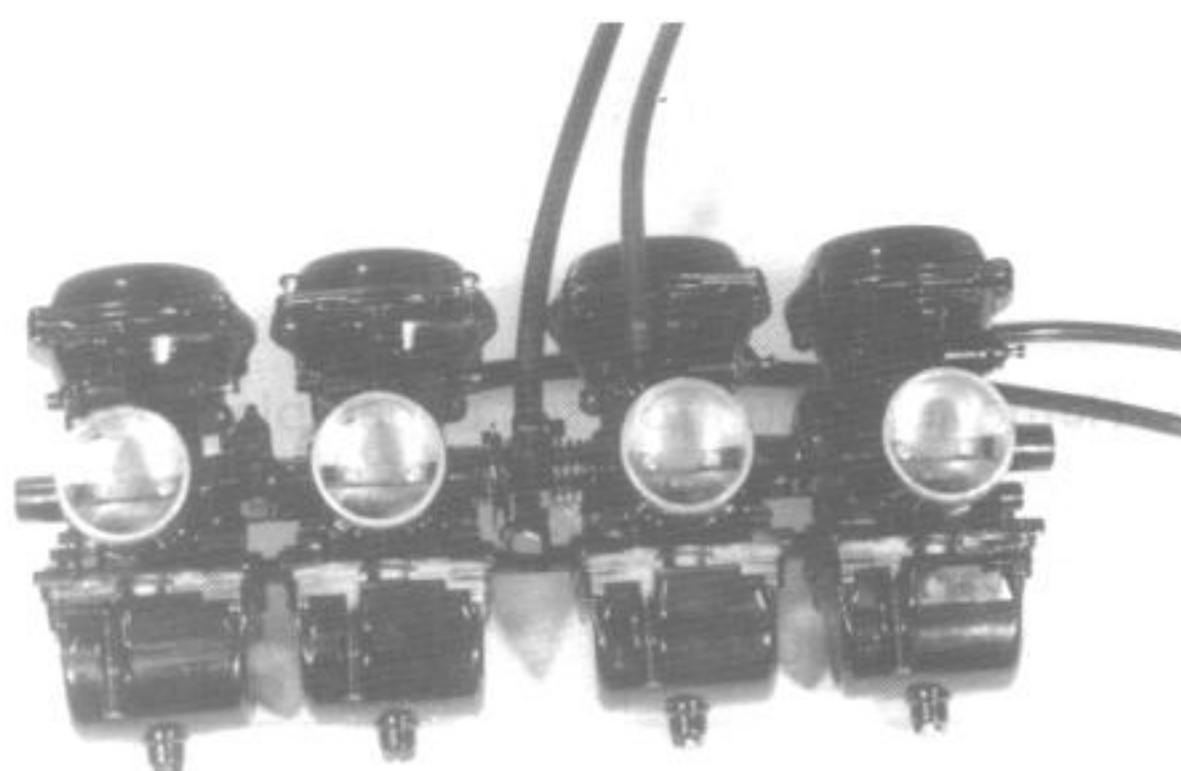

- Take off carburetor top cap by unscrewing 4 screws. Remove the piston spring and piston.

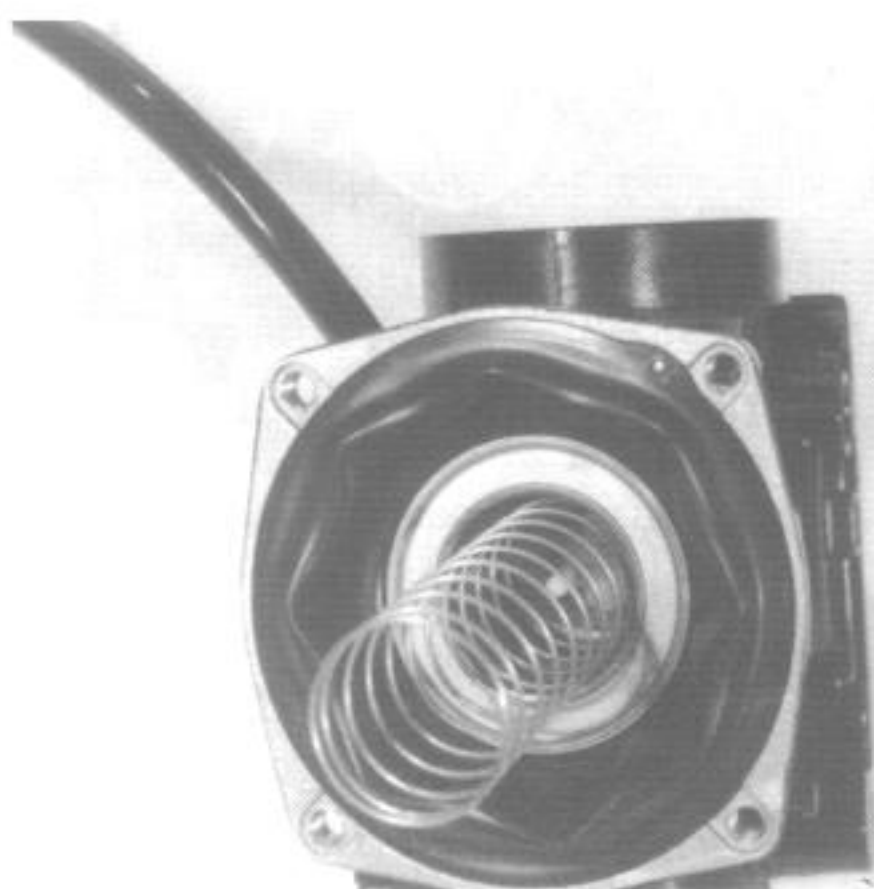

- Remove circlip ② from piston.

09900-06108

Snapping pliers

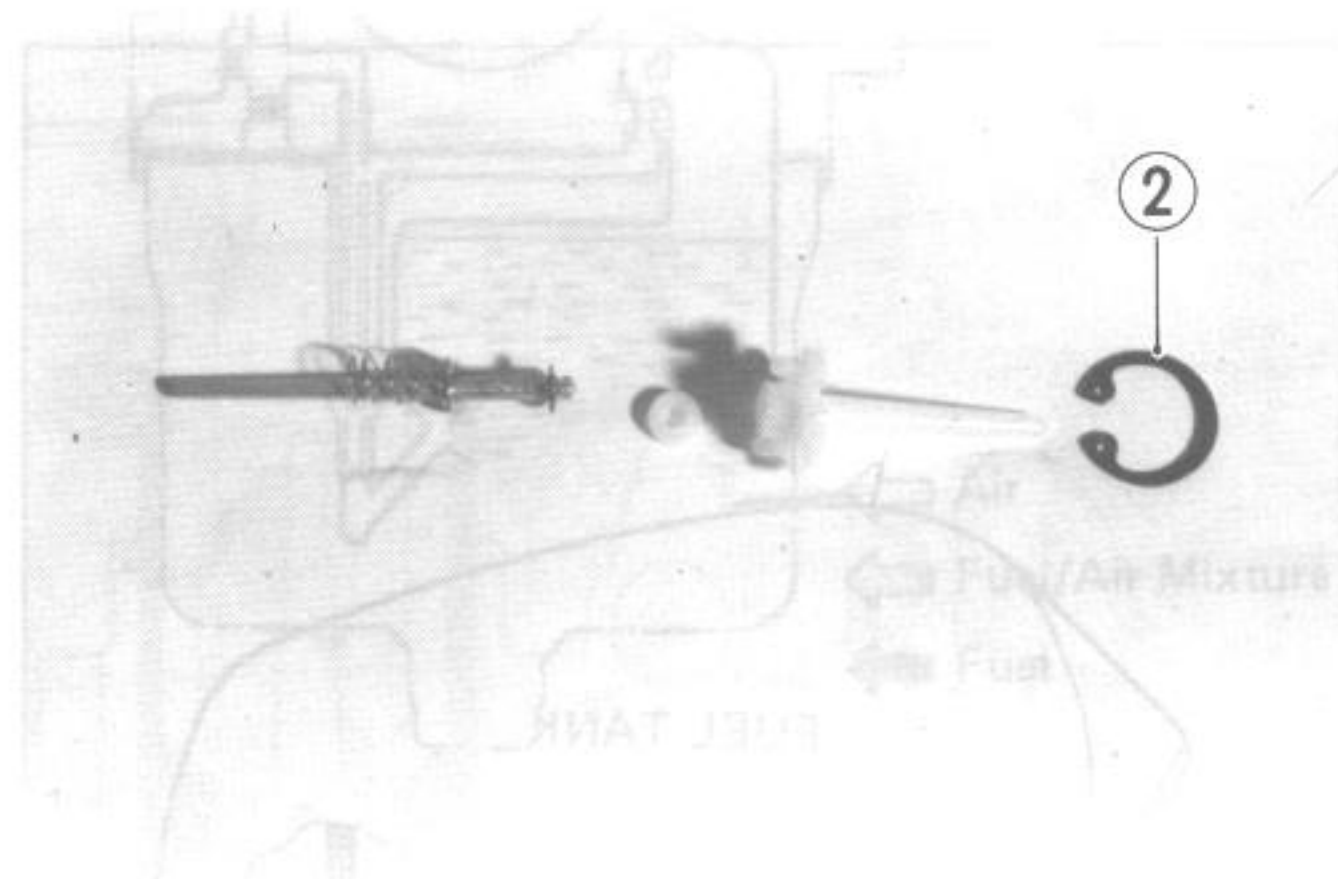
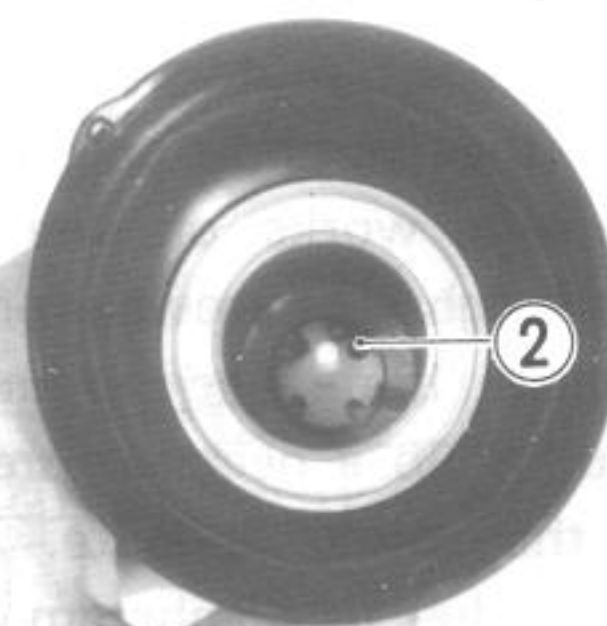

- Remove two throttle valve screws ③ by using impact driver.

09900-09003

Impact driver set

CAUTION:

These two screws are locked by punching its end. Once removing the screws, they will be damaged.

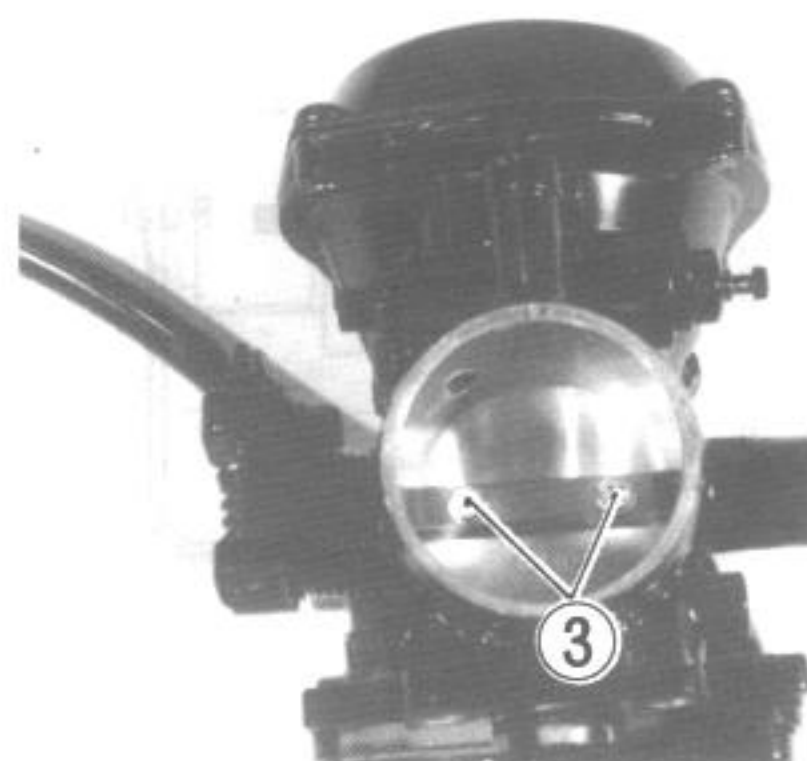

- After removing E-ring ① and washer, pull out the valve by turning throttle valve shaft.

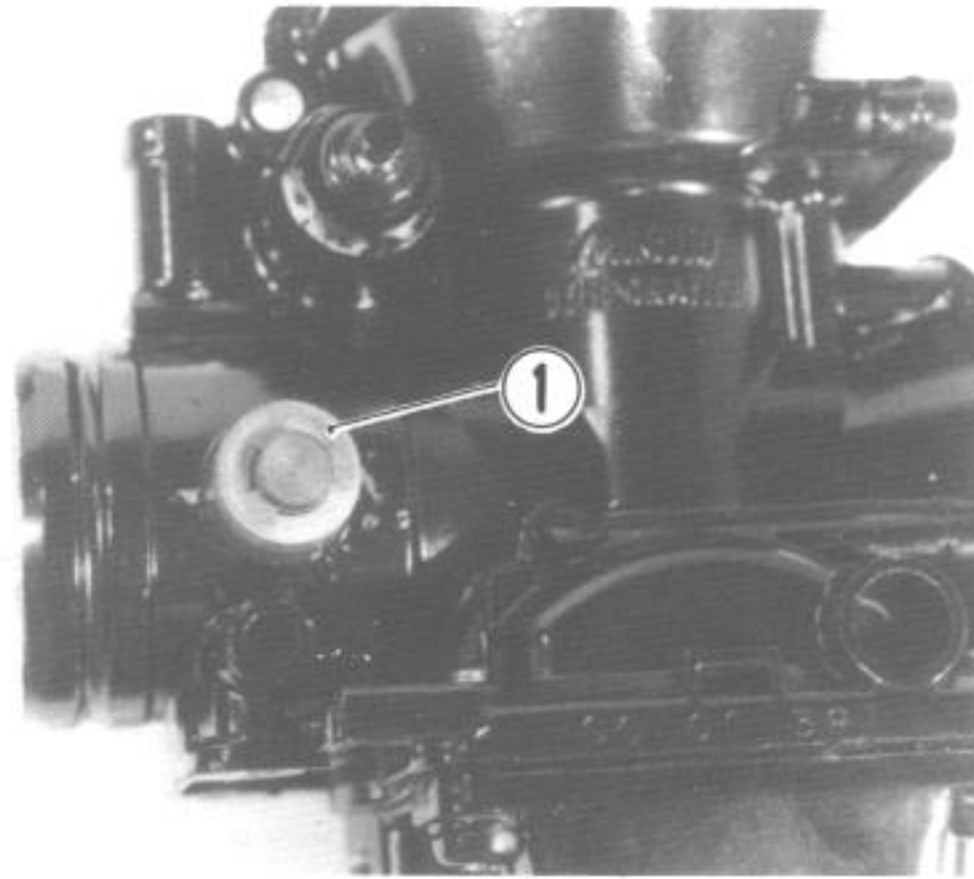

- Remove the starter plunger from the carburetor body.

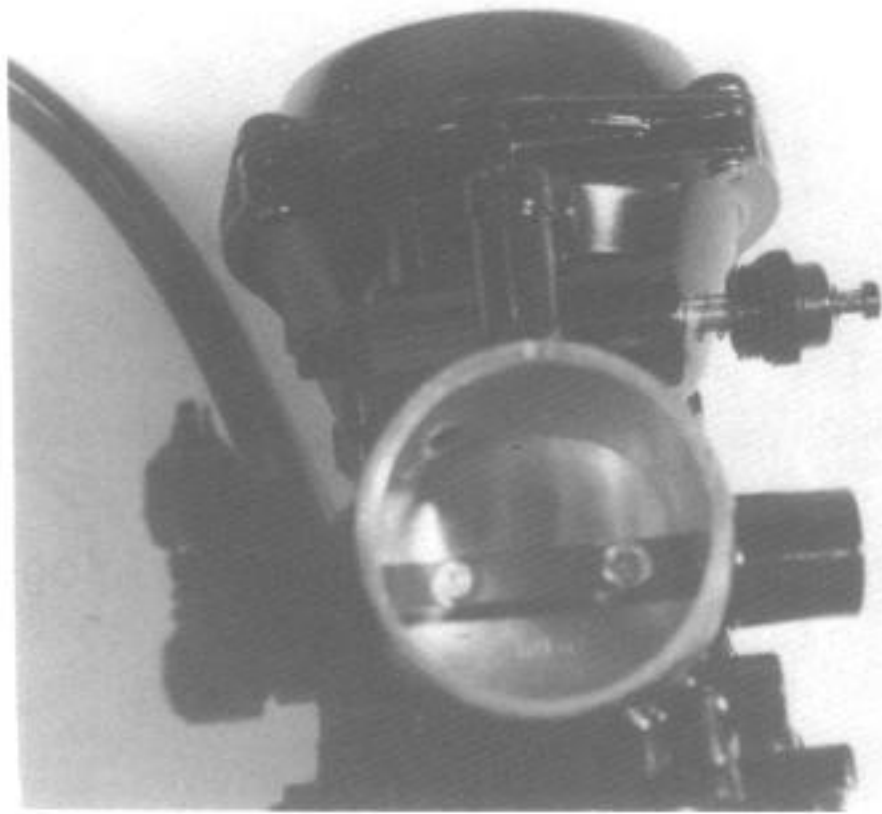

- Remove the 4 float chamber screws ② and remove the float chamber and gasket.

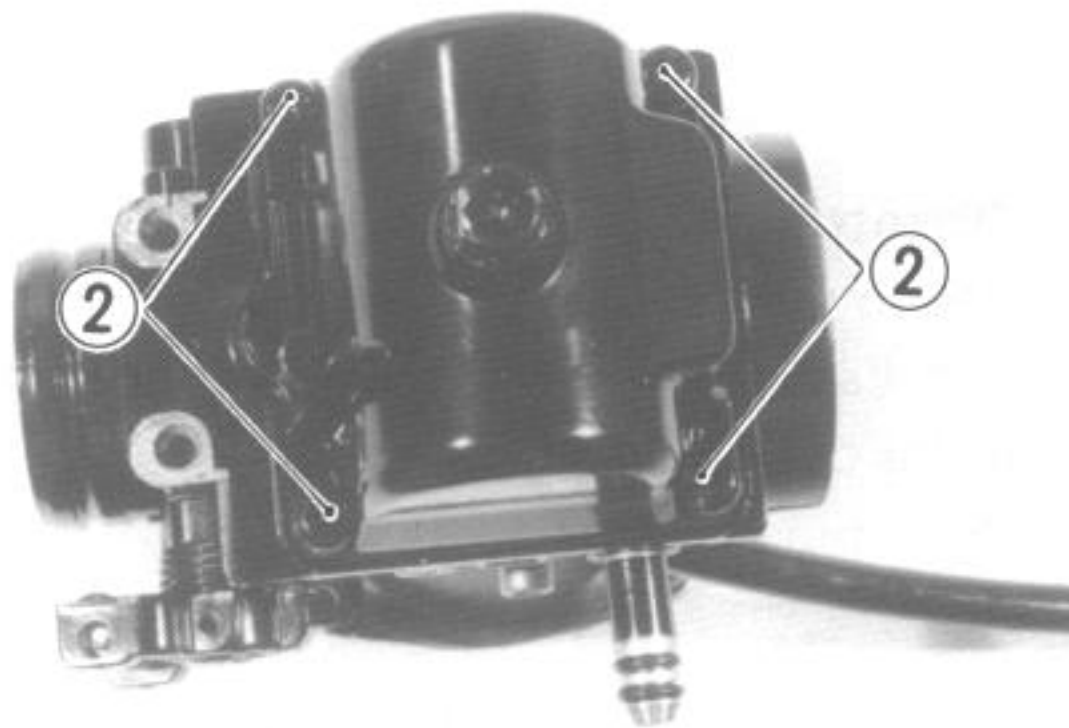

- Remove float ③, needle valve ④, main jet ⑤ and pilot jet ⑥.

CAUTION:

Use care removing the float pivot pin or damage to the carburetor body float pivot boss may occur.

- Remove the needle jet from the top side.

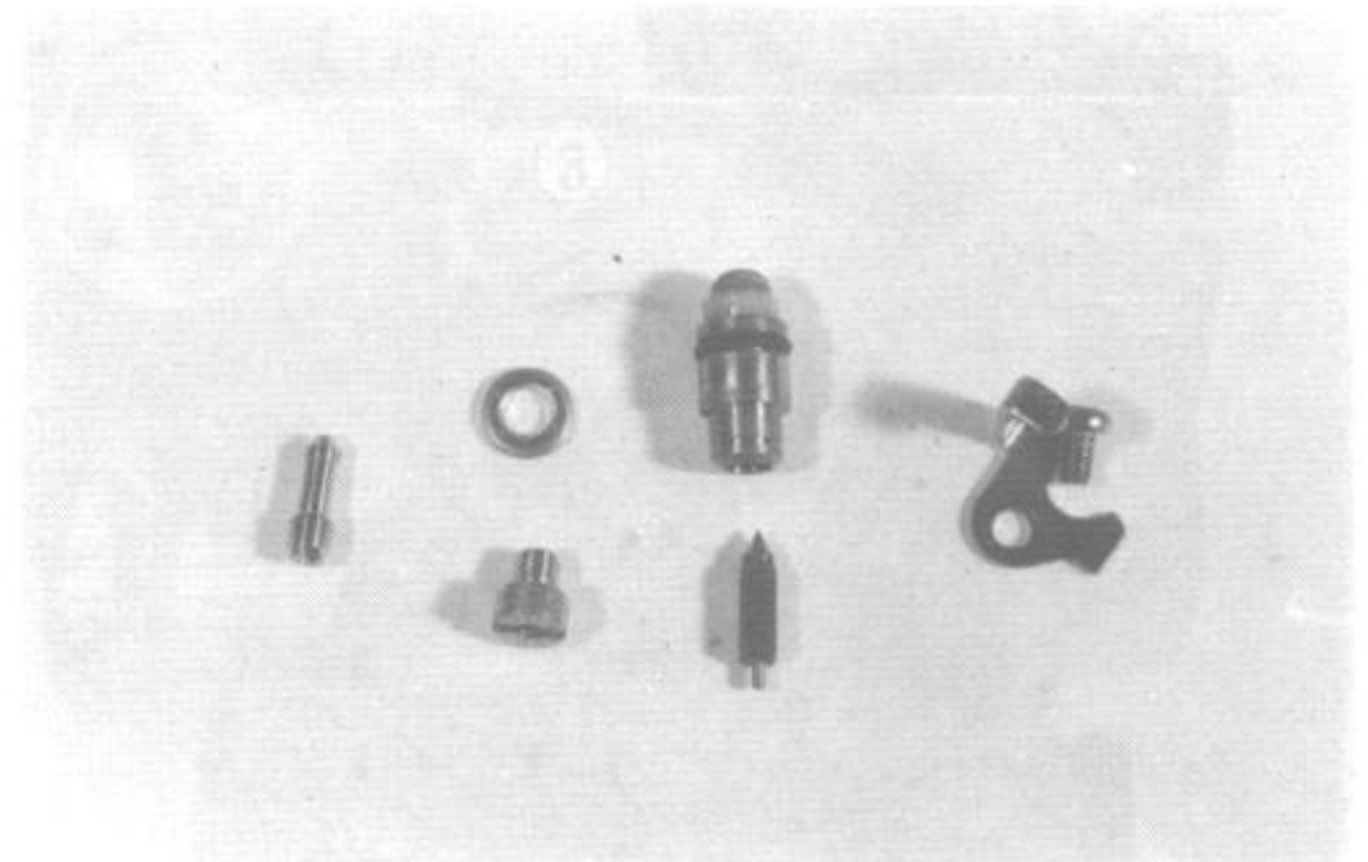
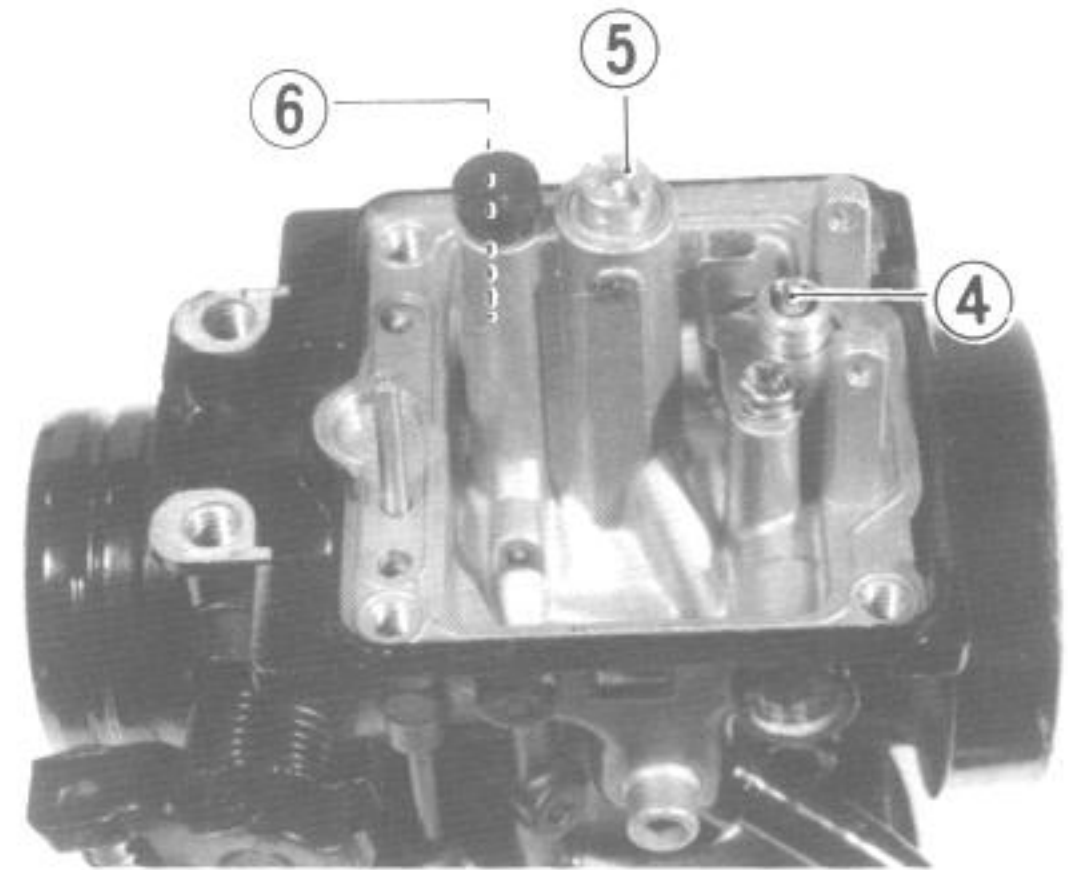
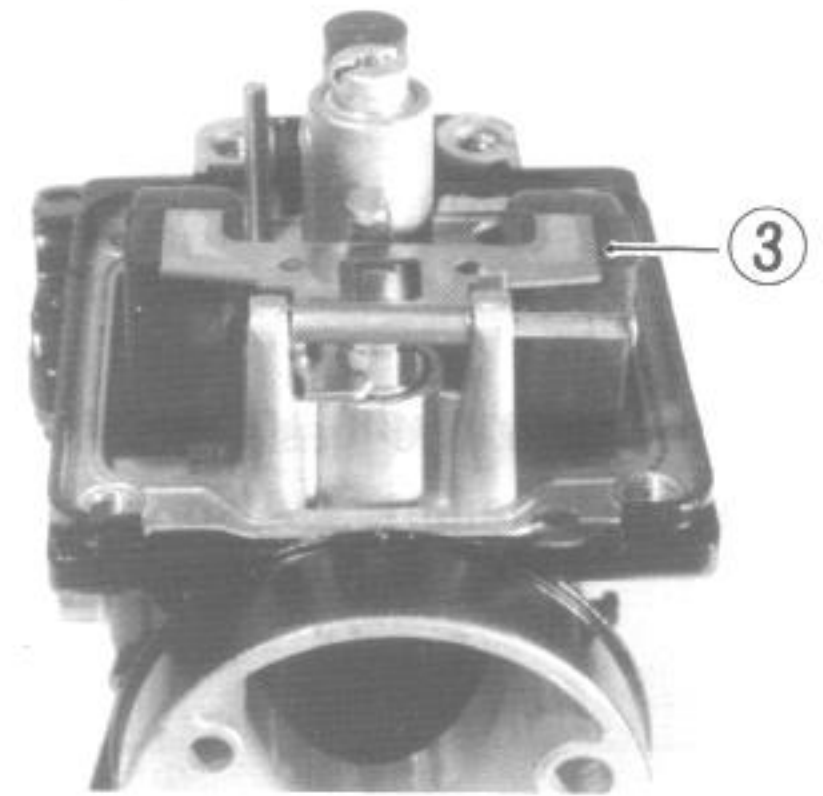

NOTE:

Identify the four piston valves removed as No. 1 through No. 4, in order to make sure each will be restored to the carburetor from which it was taken out.

FLOAT HEIGHT ADJUSTMENT

To check the float height, invert the carburetor body, holding the float arm pin so that the pin will not slip off. With the float arm kept free, measure the height **A** while float arm is just in contact with needle valve by using the calipers.

Bend the tongue **1** as necessary to bring the height **A** to this value.

NOTE:

Be sure to have the gasket removed before measuring the height. Also be sure not to compress the spring in the needle valve.

Float height **A**

21.4 ± 1.0 mm

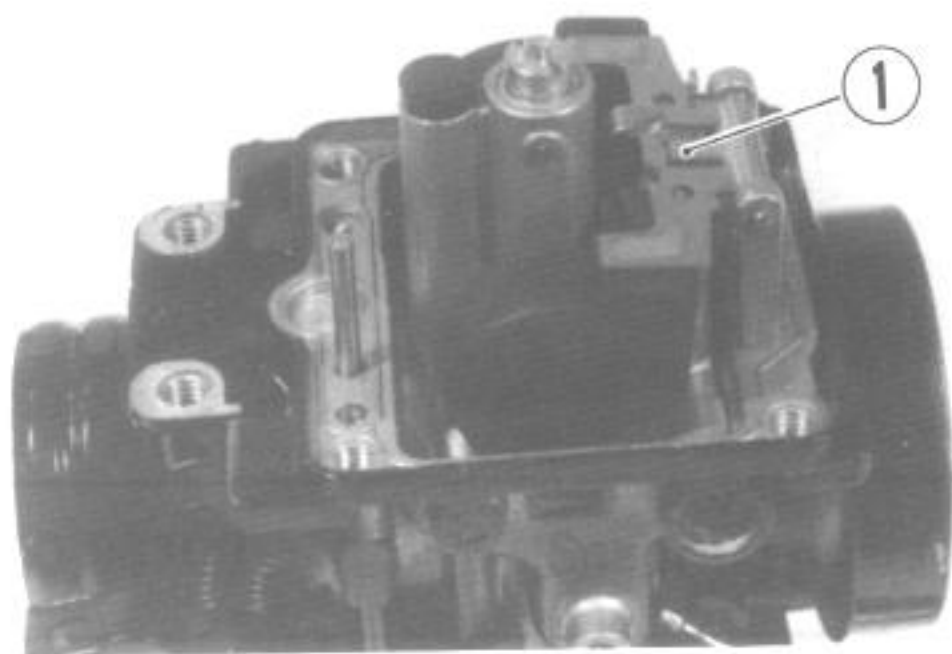
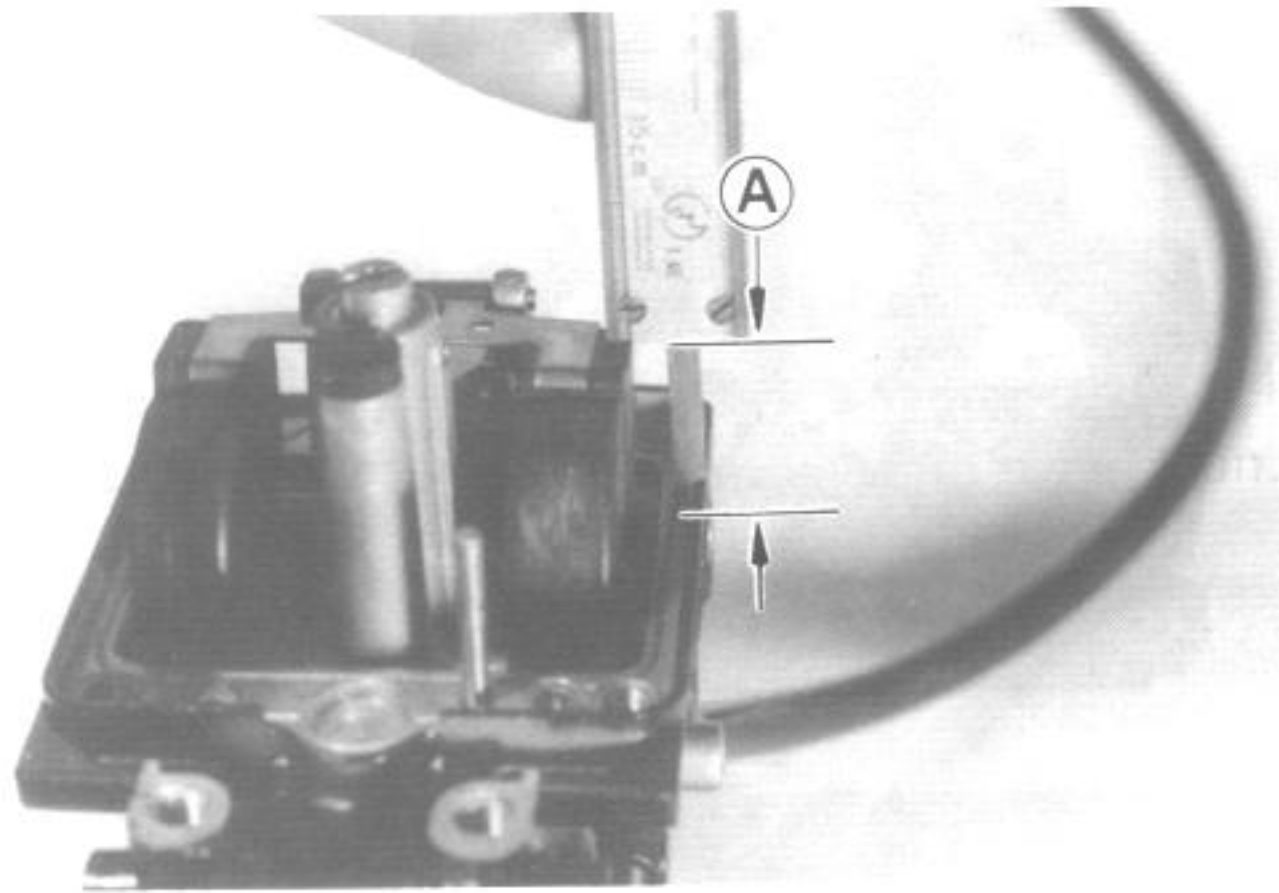
**NEEDLE VALVE**

If foreign matter is caught between the valve seat and the needle, the gasoline will continue flowing and cause it to overflow. If the seat and needle are worn out beyond the permissible limits, similar trouble will occur. Conversely, if the needle sticks, the gasoline will not flow into the float chamber. Remove the carburetor, float chamber and floats, and clean the float chamber and float parts with gasoline. If the needle is worn as shown below, replace it together with a valve seat. Clean the fuel passage of the mixing chamber with compressed air.

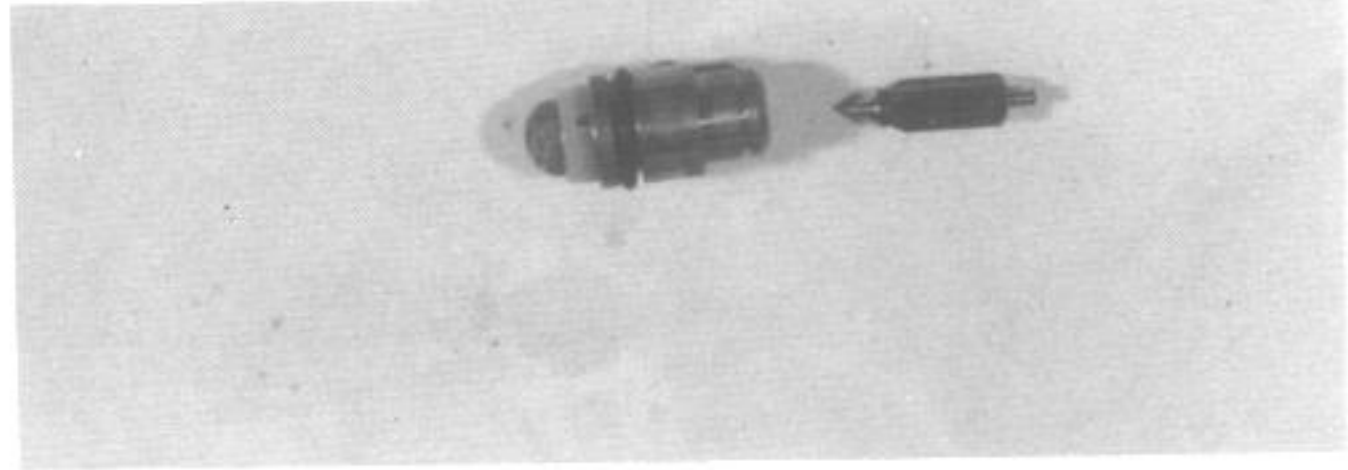
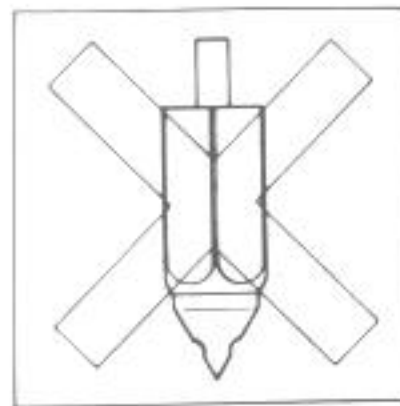

- Check following items for any damage or clogging.
 - * Pilot jet
 - * Main jet
 - * Main air jet
 - * Pilot air jet
 - * Needle jet air bleeding holes
 - * Float
 - * Needle valve mesh and O-ring
 - * Diaphragm
 - * Gasket and O-ring
 - * Throttle valve shaft oil seals
 - * Drain plug O-ring
 - * Pilot screw bleeding hole and rubber cap
 - * Pilot outlet and bypass holes
 - * Fuel pipe O-rings

REASSEMBLY

- Align the groove ① of the needle jet with the pin ② and replace it.

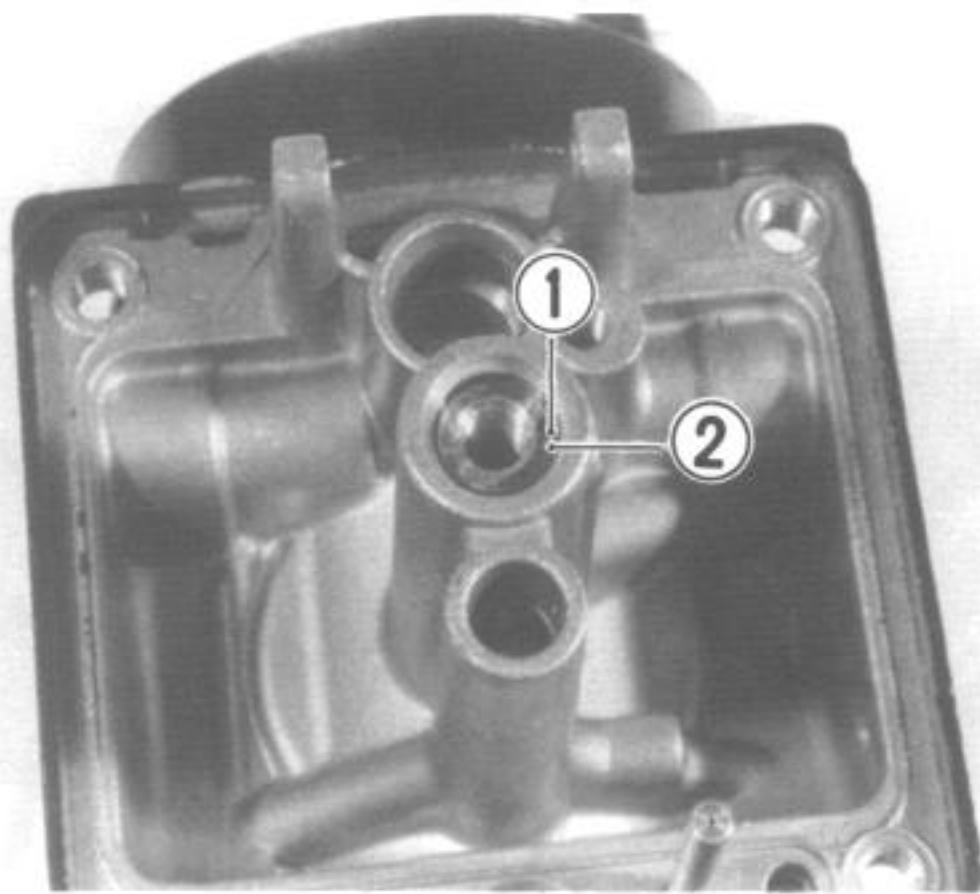

- Hitch one end of spring to the boss ① and turn the other end ② clockwise by one turn and hitch it to the throttle valve shaft lever properly.

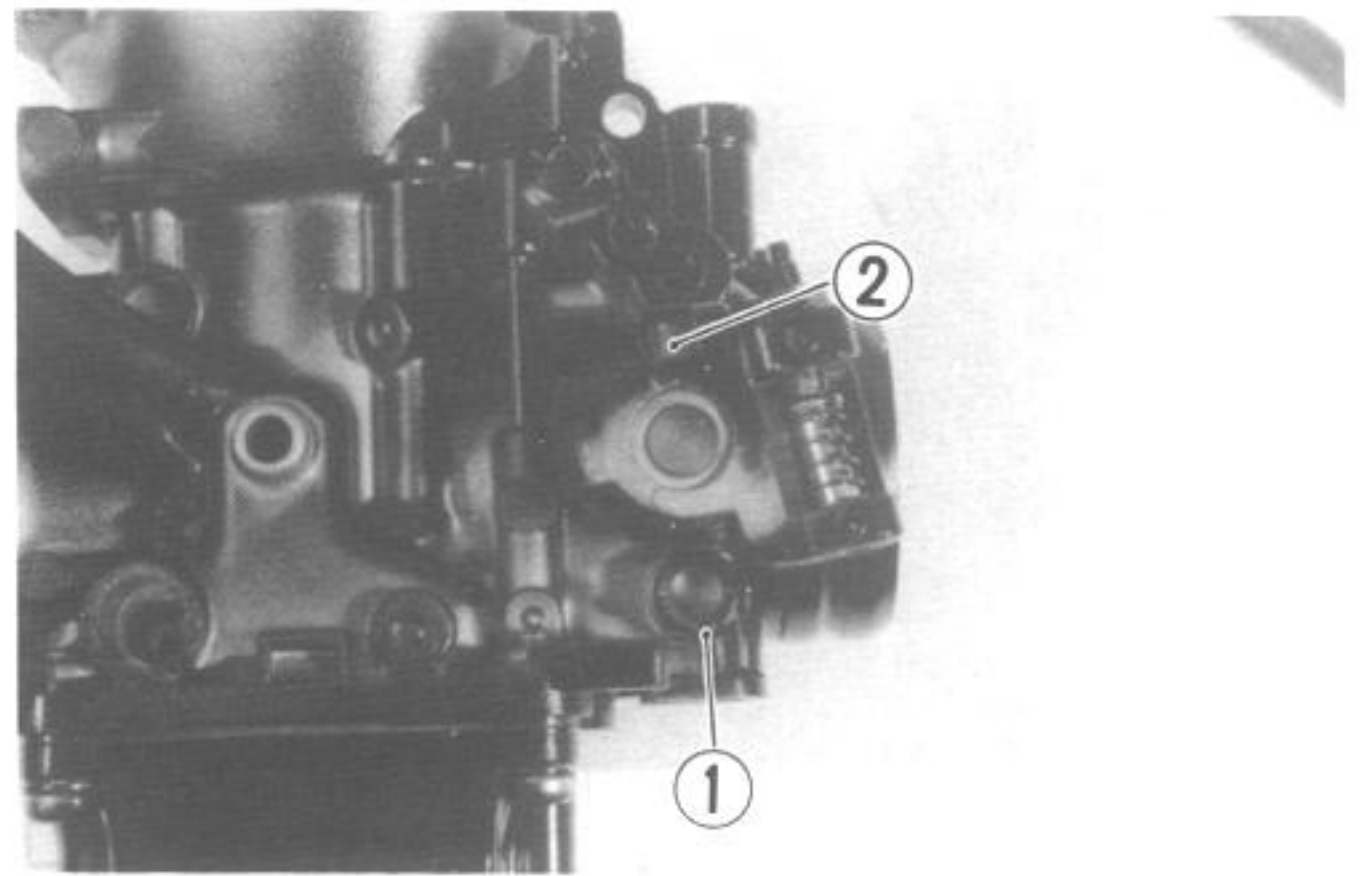

- Place tongue ③ of diaphragm to carburetor body properly.

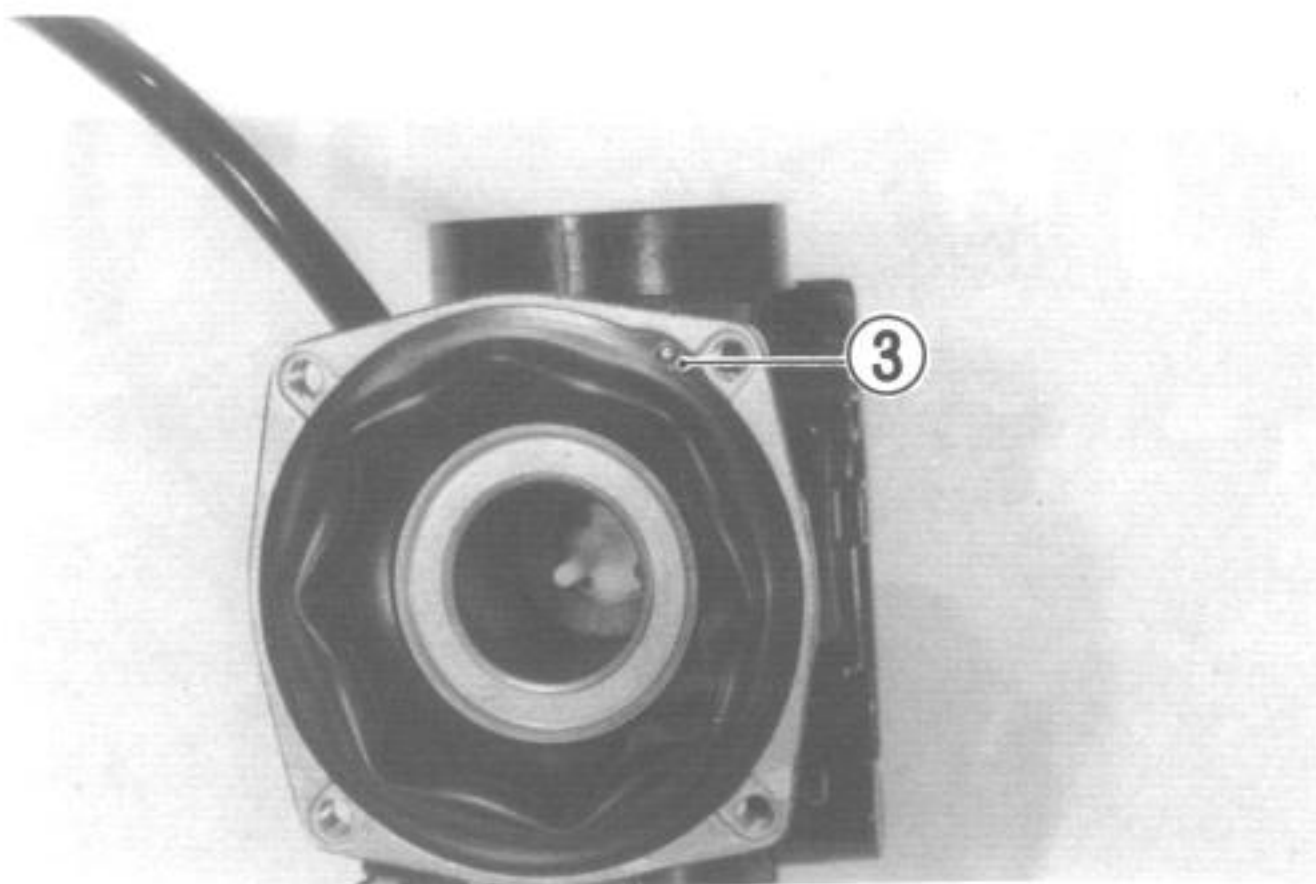

- Install the washer and clip properly.

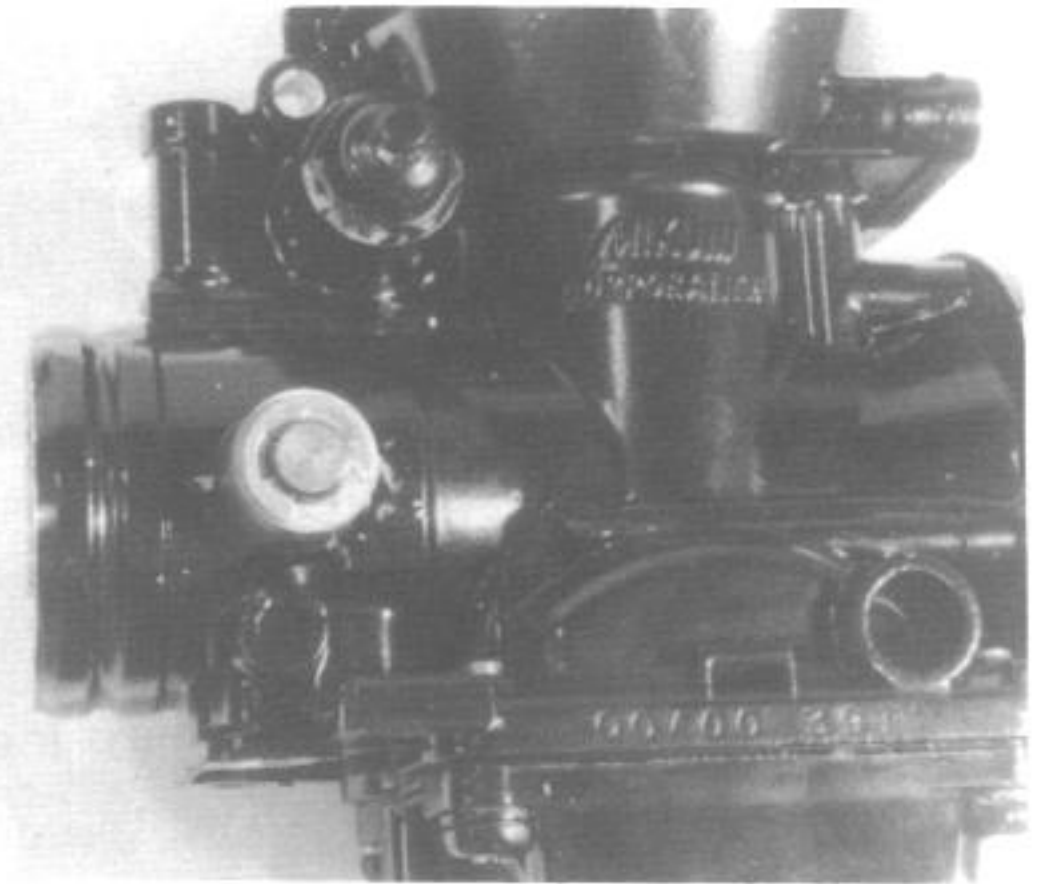

- When fitting throttle valve shaft oil seals, groove should be faced outside ①. Apply grease to lip of oil seal.

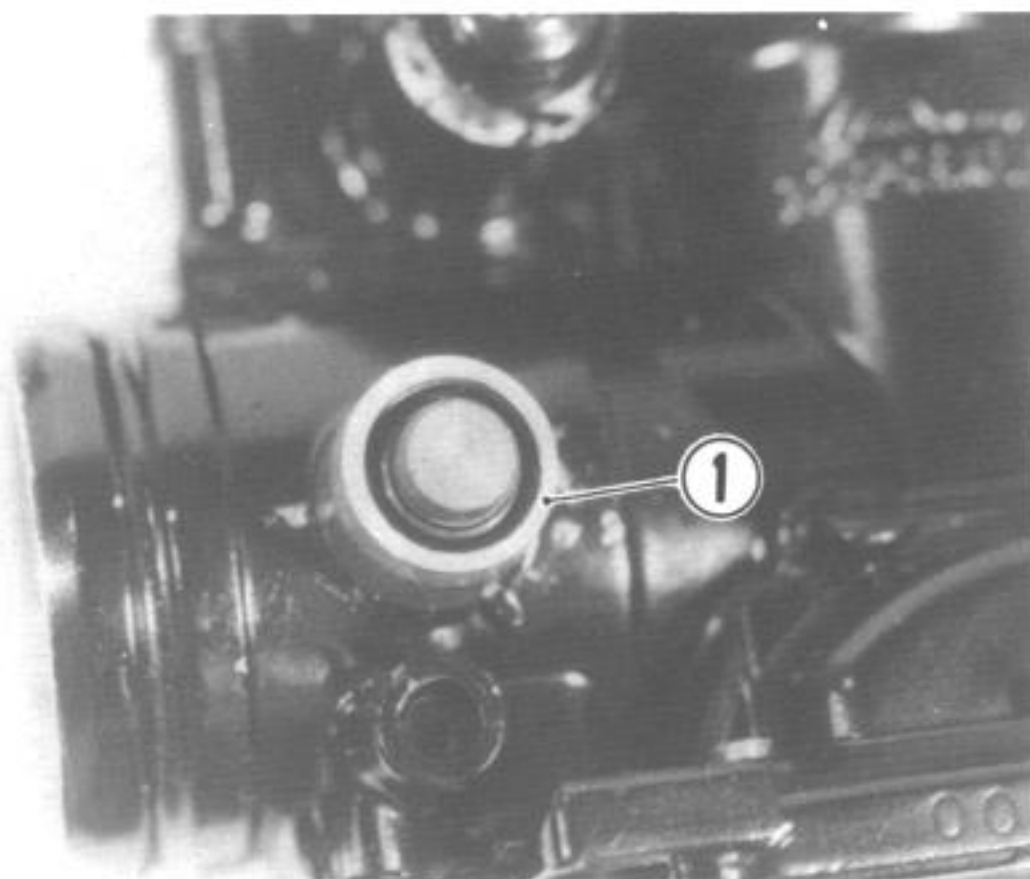

- When engaging four carburetors, be sure to fix fuel pipe ① with four O-ring ② and breather connector ③ properly.

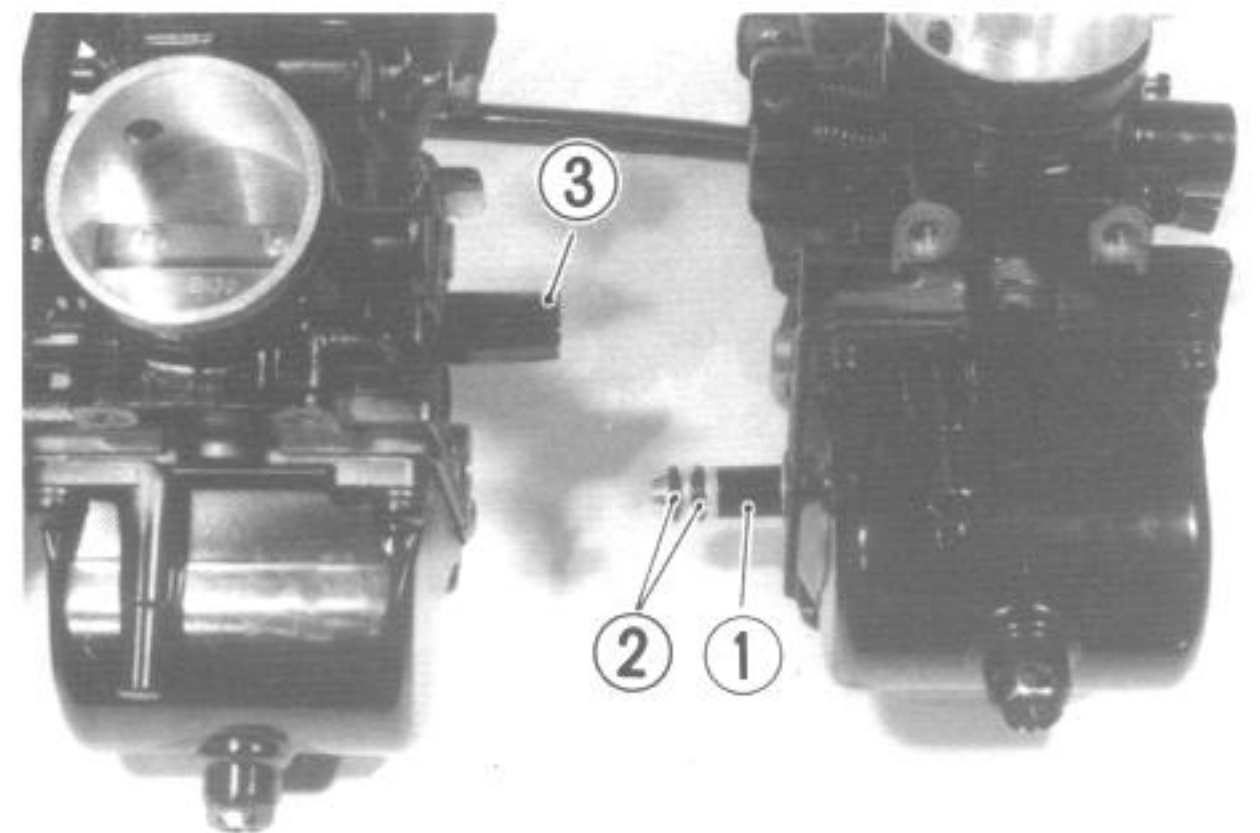

- Position throttle valve control lever ① correctly.

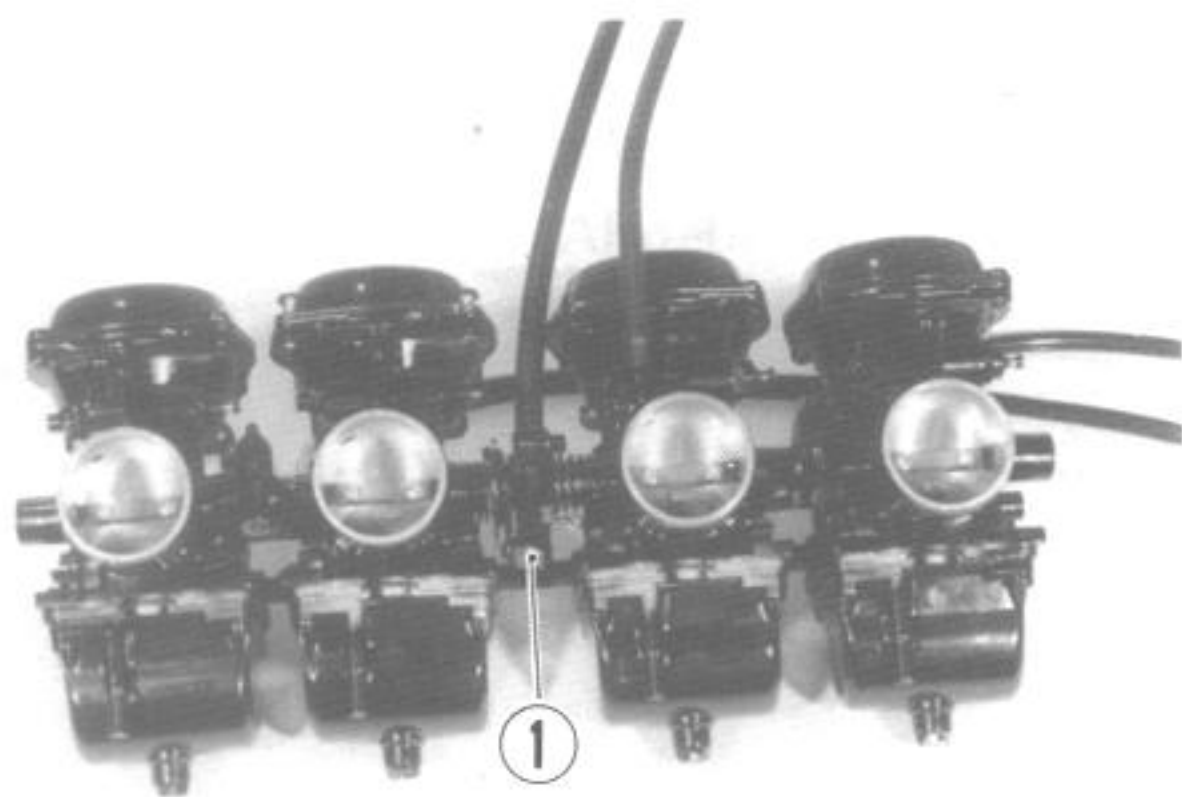
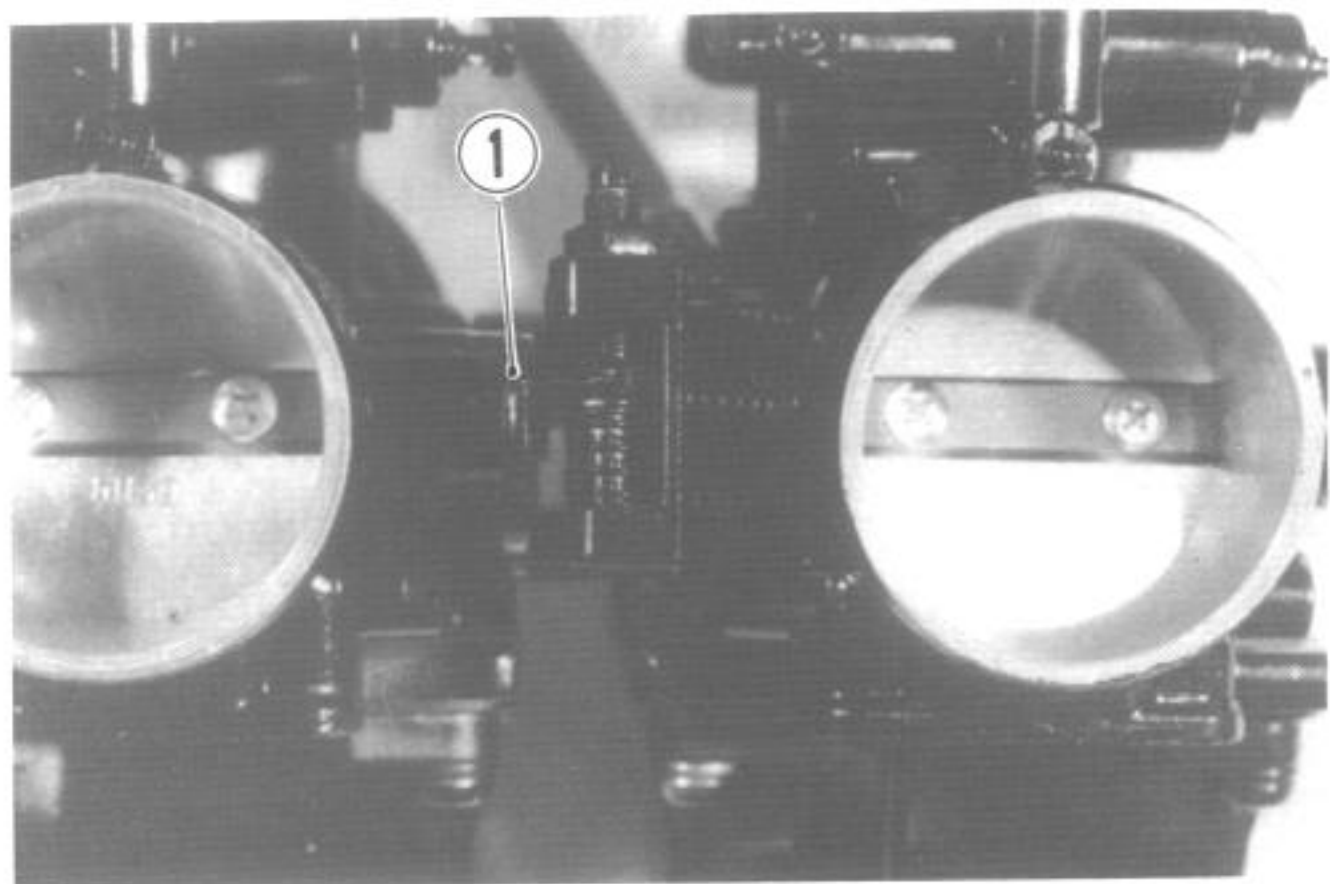

- Apply thread lock cement to lower bracket screws ②.
- Fix the clutch cable guide ③ properly.

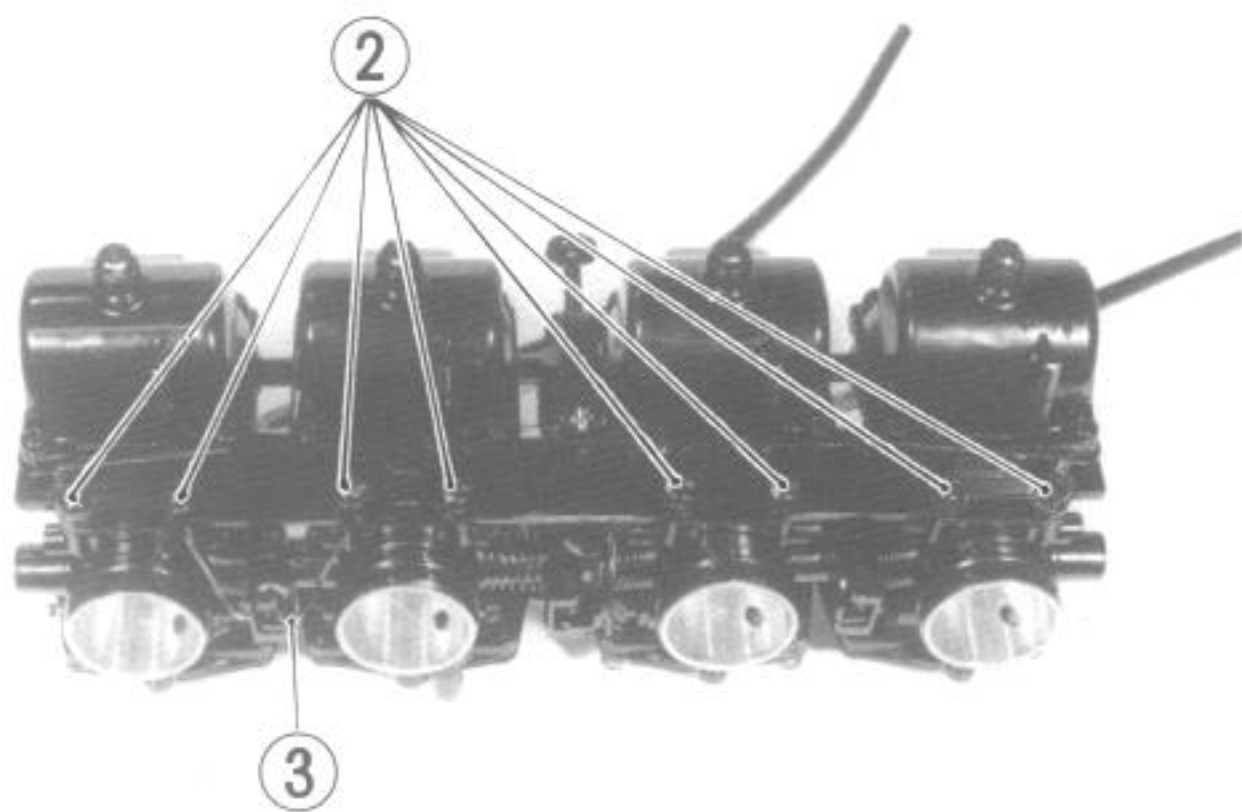

- Apply thread lock cement to the upper bracket screws.

99000-32040	Thread lock cement
-------------	--------------------

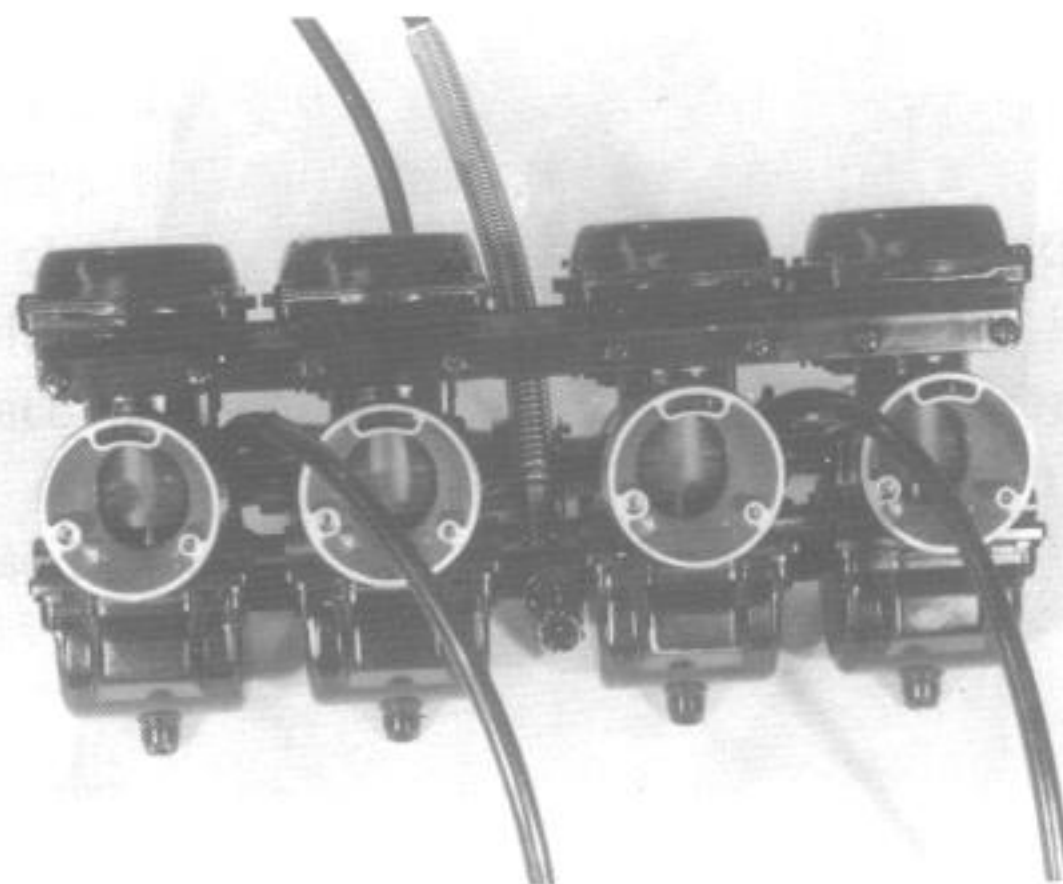

- Place the starter cable guide ④ as shown.

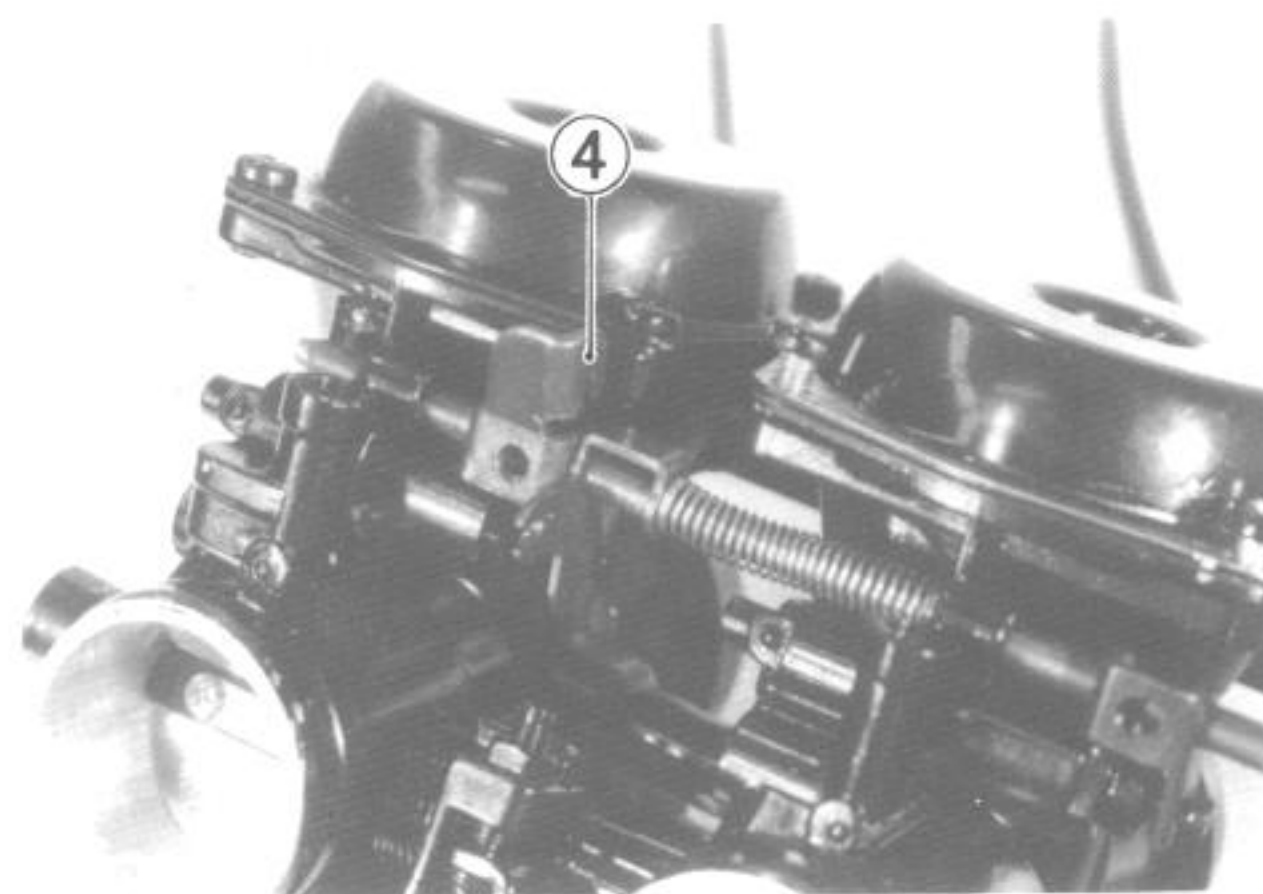

- When mounting starter shaft, align starter valve screw ⑤ with dent mark ⑥ on starter shaft and grease sliding portions.

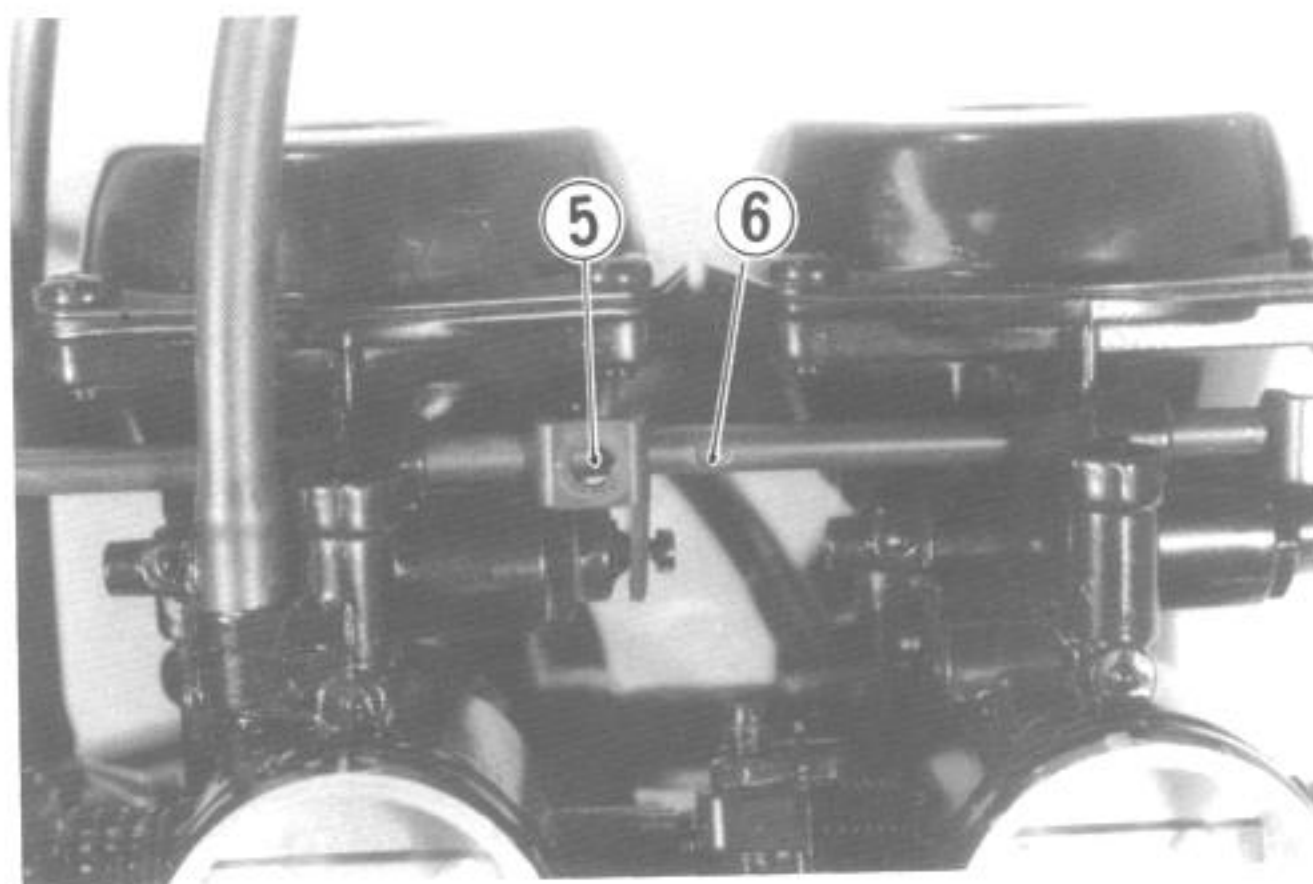

- Apply thread lock cement to starter shaft securing screws ①.

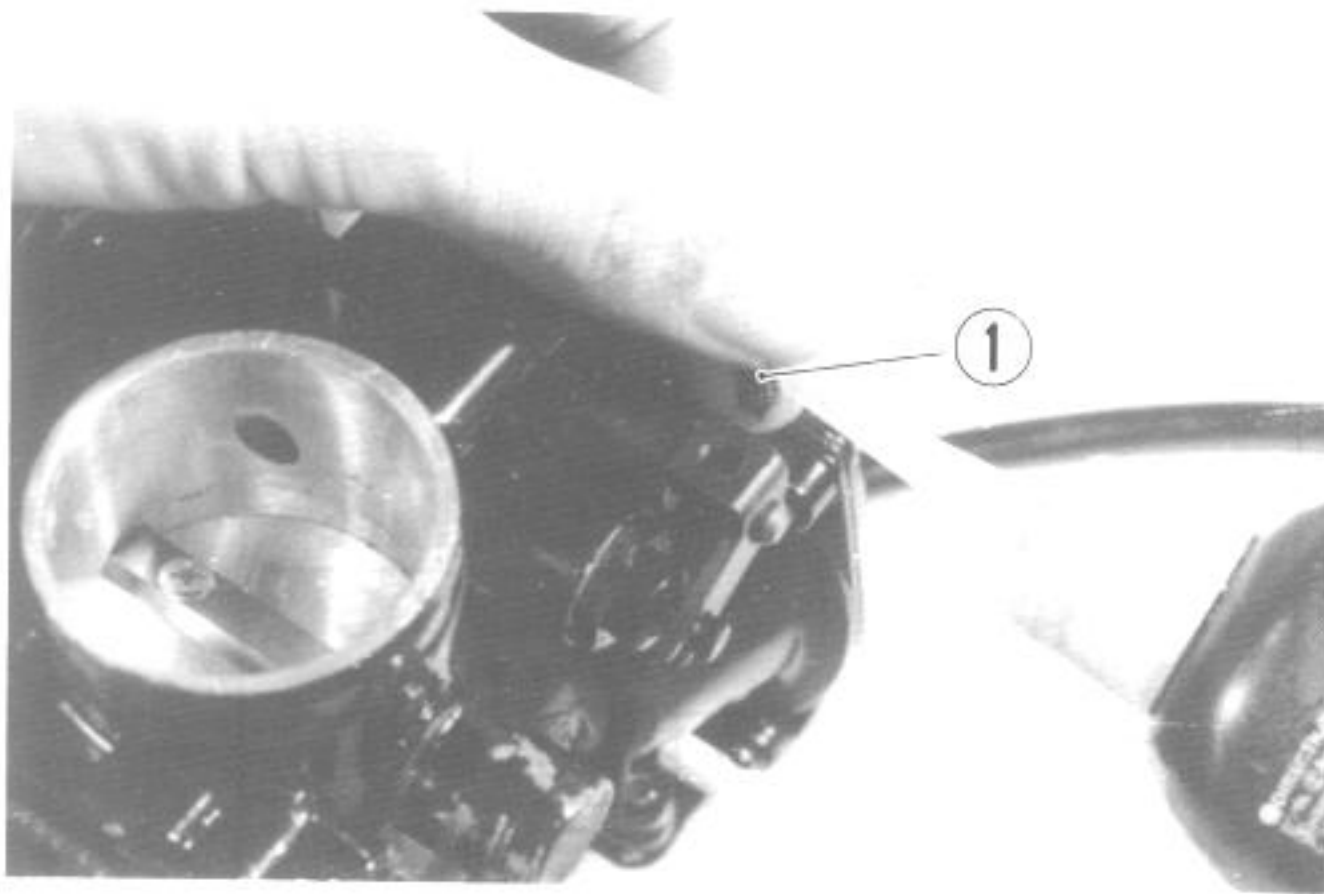

- Set each throttle valve in such a way that its top end ① meets the foremost bypass ②. This is accomplished by turning throttle valve stop screw ③ and balance screw ④.

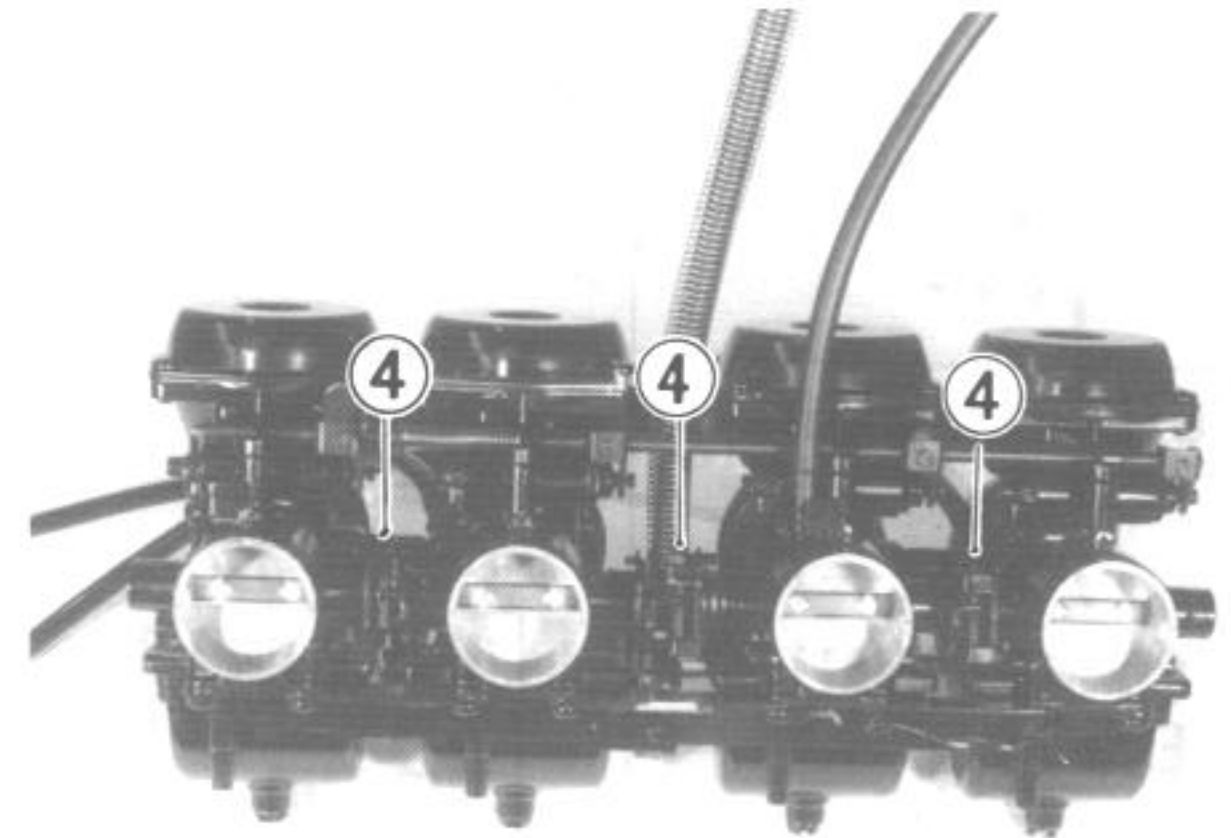
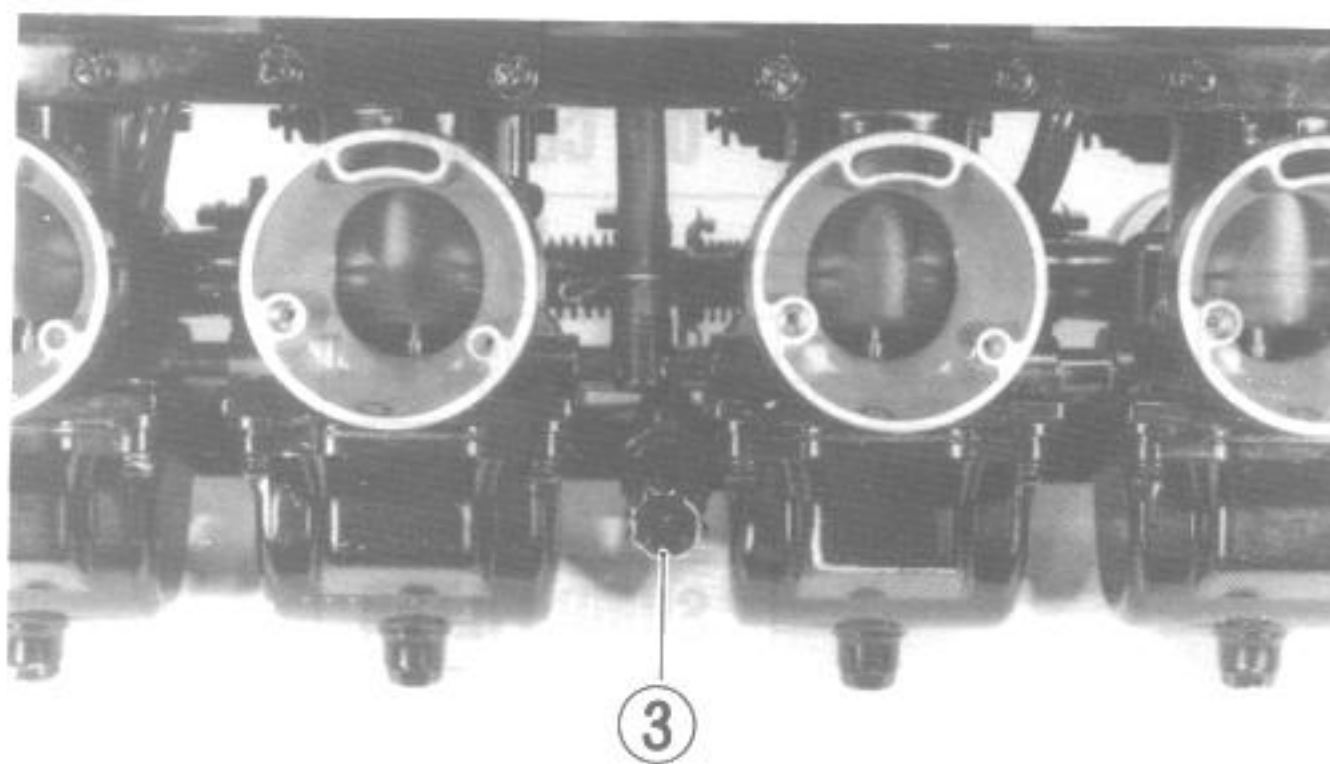
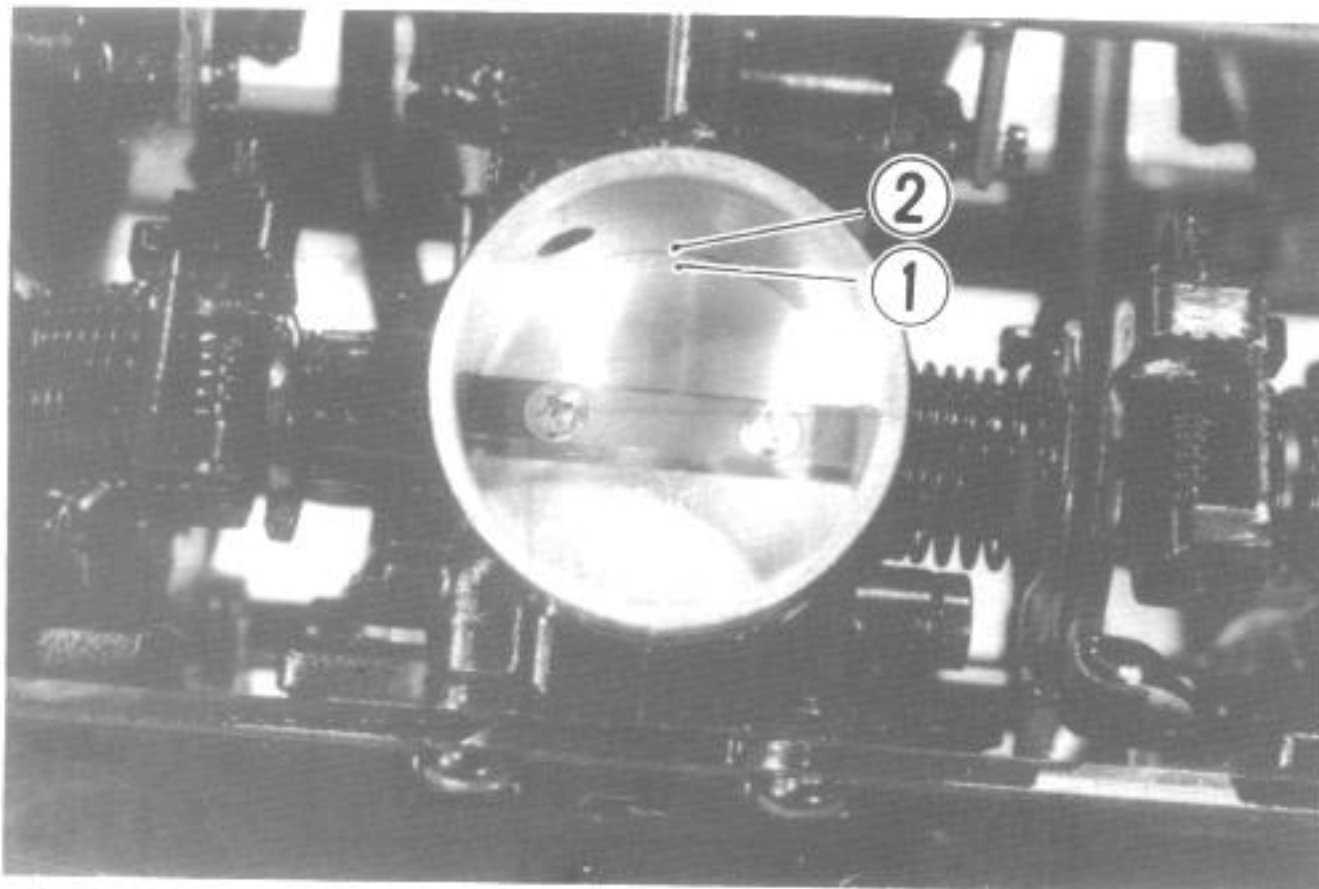

09913-14911	Throttle valve adjust wrench
-------------	------------------------------

NOTE:

When adjusting the throttle balance screws, adjusting order is as follows:

Ⓐ (for No. 2 Carb.) → Ⓑ (for No. 1) → Ⓒ (for No. 4)

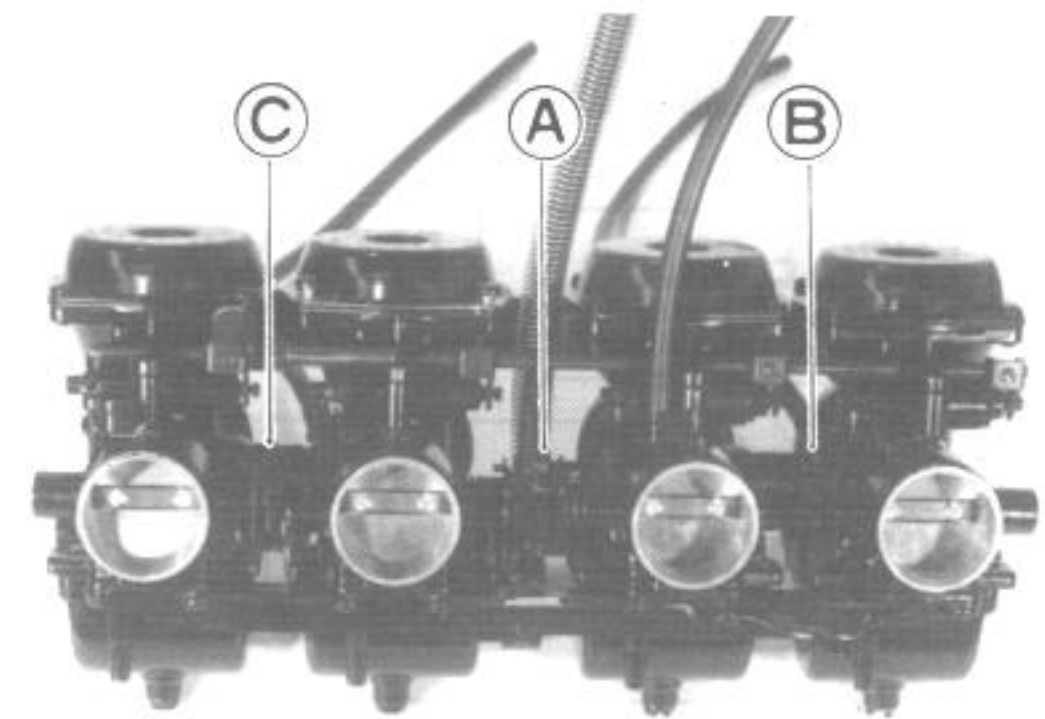

After all work is completed, mount the carburetors on the engine and the following adjustments are necessary. (See page 2-10).

- * Engine idle r/min
- * Throttle cable play
- * Balancing carburetors

LUBRICATION SYSTEM

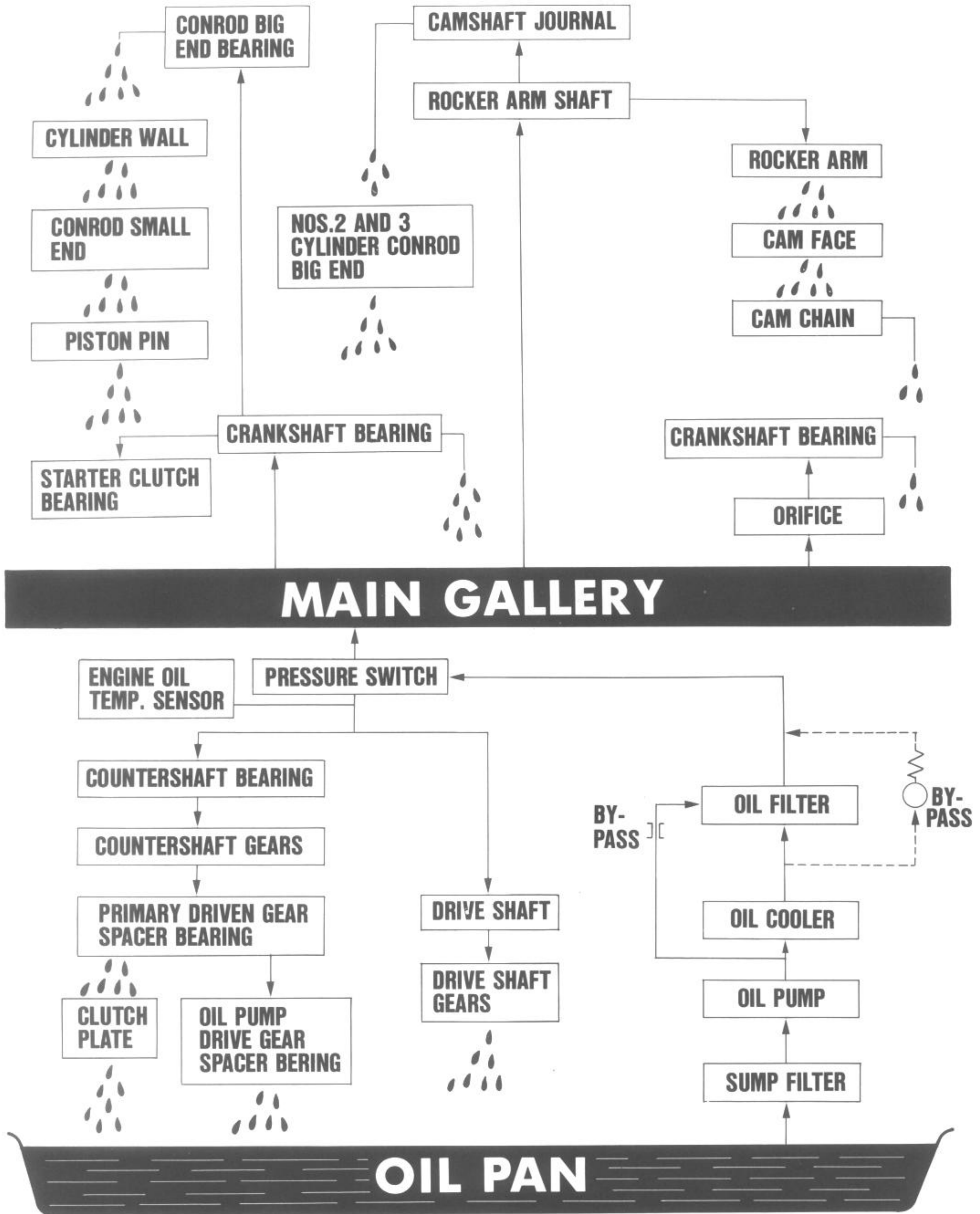

ELECTRICAL

CONTENTS

IGNITION SYSTEM	5- 1
CHARGING SYSTEM	5- 4
STARTER SYSTEM	5- 8
COMBINATION METER	5-12
COIL TYPE FUEL GAUGE	5-14
ENGINE OIL TEMPERATURE METER	5-16
MONITOR SYSTEM	5-17
LAMPS	5-20
SWITCHES	5-21
SELF CANCELLING DEVICE	5-25
BATTERY	5-27

IGNITION SYSTEM

DESCRIPTION

The fully transistorized ignition system consists of a signal generator, transistor unit, ignition coils, and spark plugs. The signal generator comprises one rotor and two pick-up coils.

The signal generator is mounted at the right end of the crankshaft. The output of the signal generator goes to the transistor unit, where it turns ON and OFF the transistor alternately. As the transistor is turned ON and OFF, the current passing through the primary winding of the ignition coil is also turned OFF and ON accordingly, thus it induces the secondary current on the ignition coil secondary windings and produce the spark between spark plug gaps.

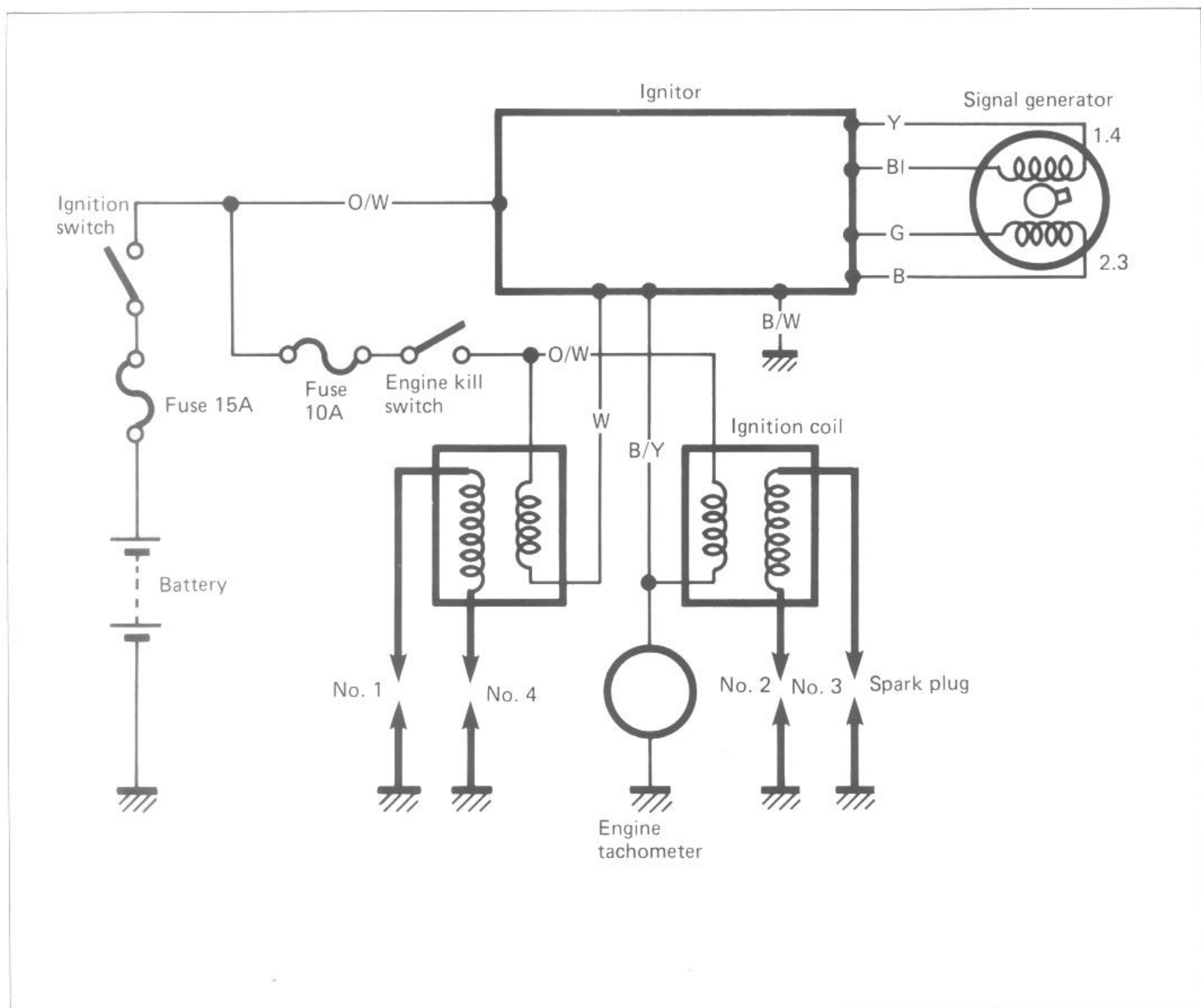

INSPECTION**IGNITION COILS****(Checking with Electro Tester)**

Using the electro tester, test each ignition coil for sparking performance. The test connection is as indicated. Make sure that the three-needle sparking distance is at least 8 mm (0.3 in).

If no sparking or orange color sparking occurs with this much gap, then it is defective and must be replaced.

09900-28106	Electro tester
-------------	----------------

STD Spark performance	8 mm (0.3 in)
-----------------------	---------------

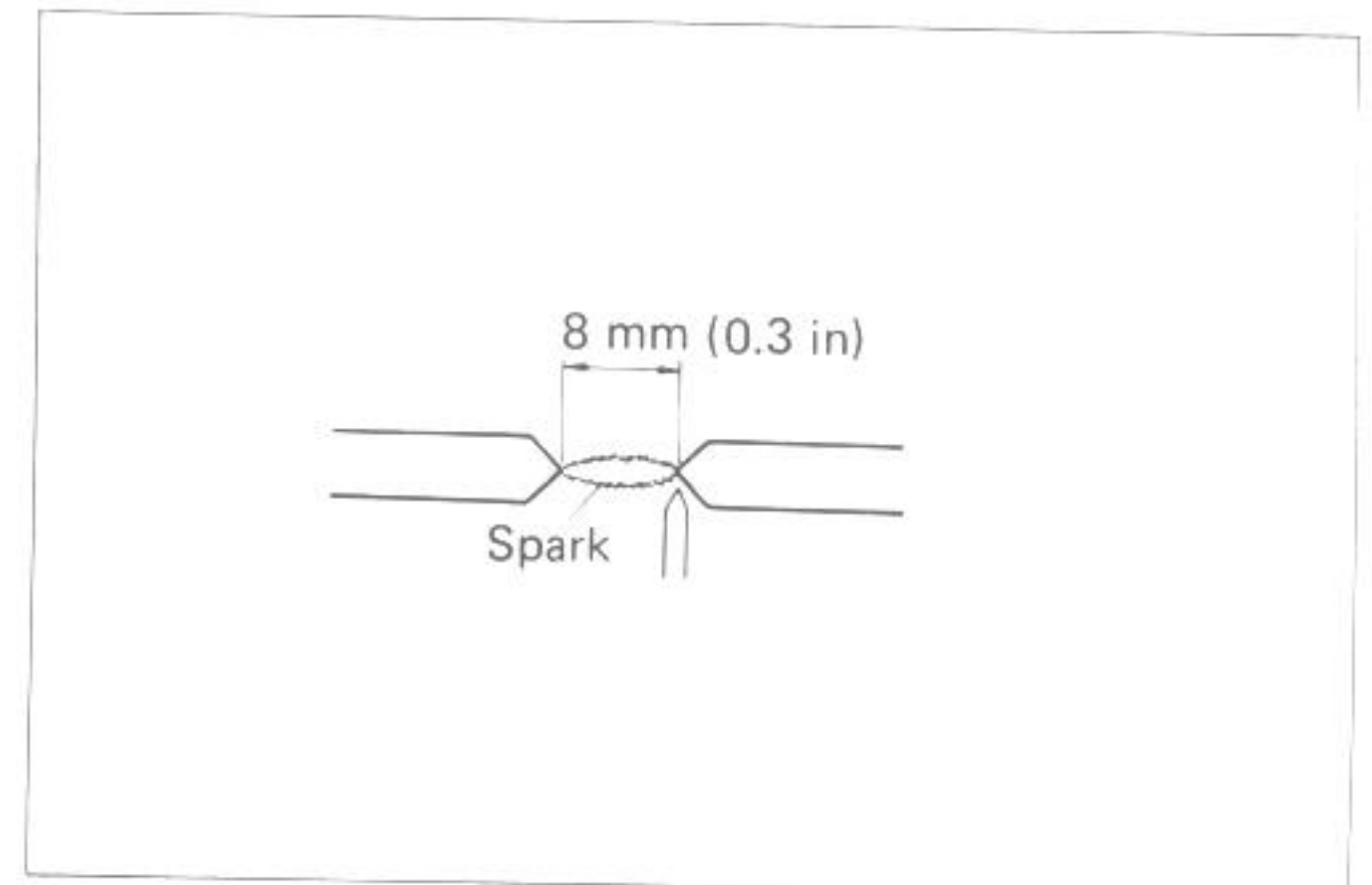
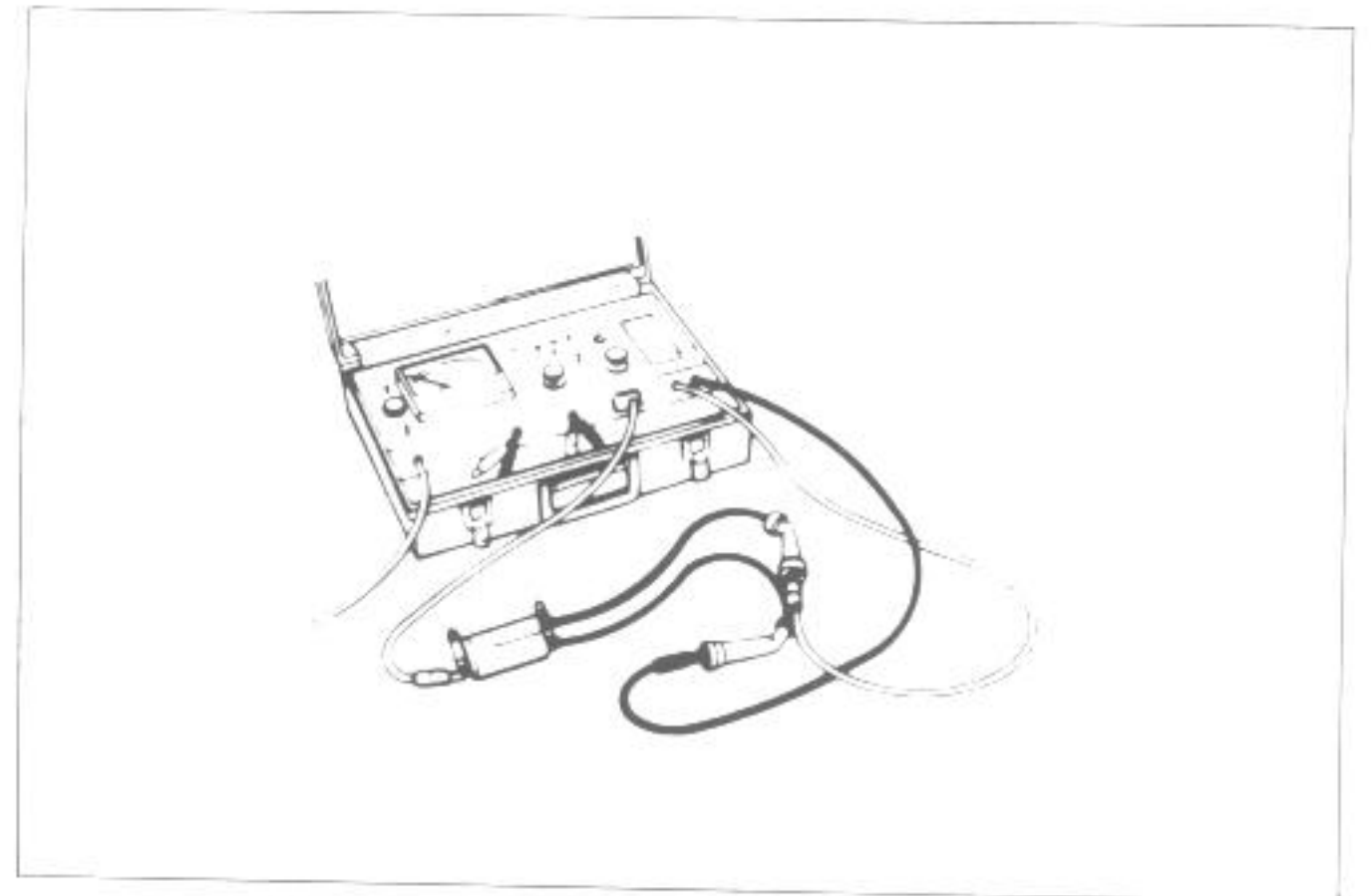
**IGNITION COILS****(Checking with Pocket Tester)**

A SUZUKI pocket tester or an ohmmeter may be used, instead of the electro tester. In either case, the ignition coil is to be checked for continuity in both primary and secondary windings. Exact ohmic readings are not necessary, but, if the windings are in sound condition, their continuity will be noted with these approximate ohmic values.

09900-25002	Pocket tester
-------------	---------------

STD Ignition coil resistance		
Primary	O/W - W	2 - 5 Ω
	O/W - B/Y	
Secondary	Plug cap - Plug cap	30 - 40 k Ω

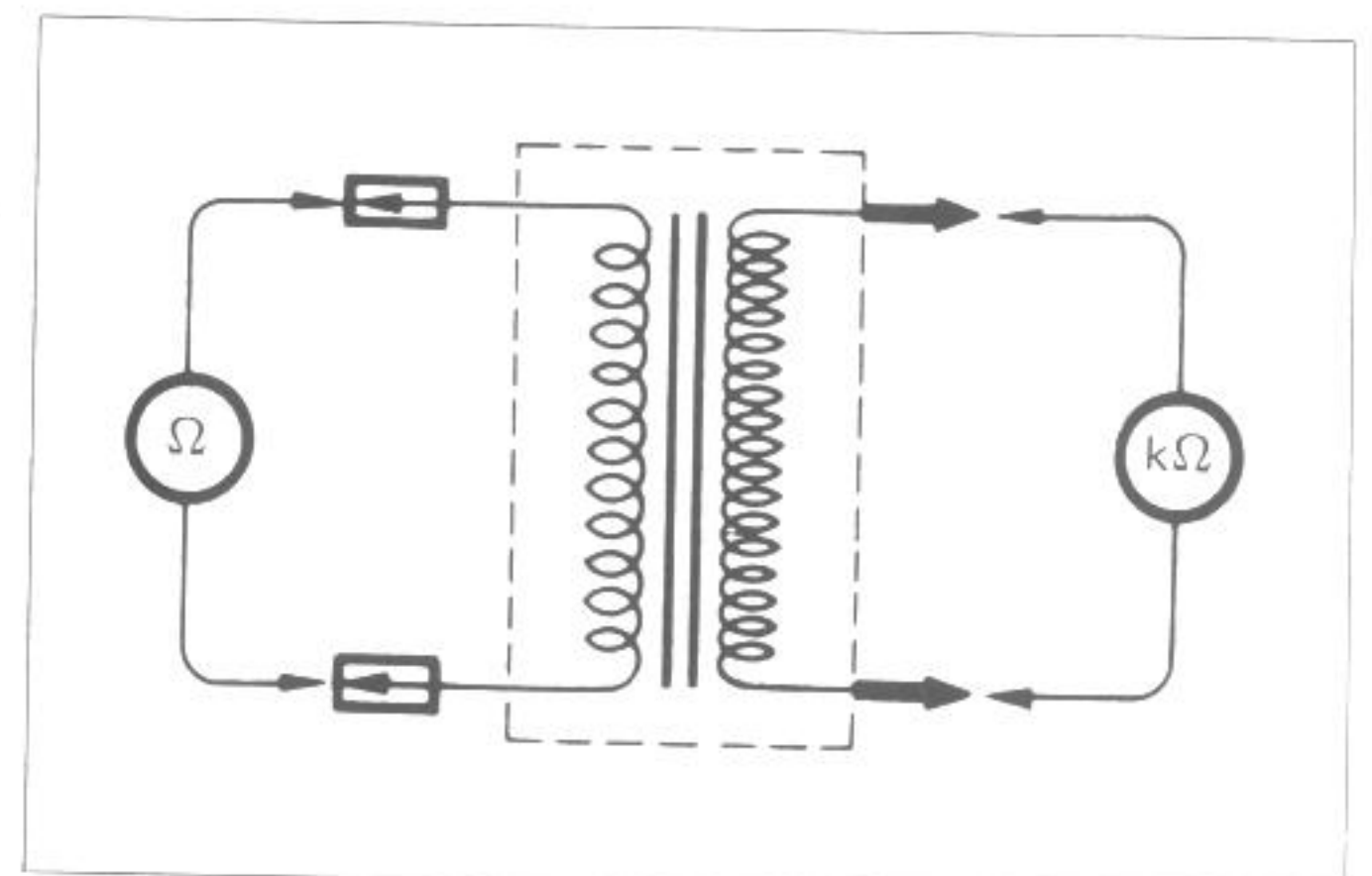
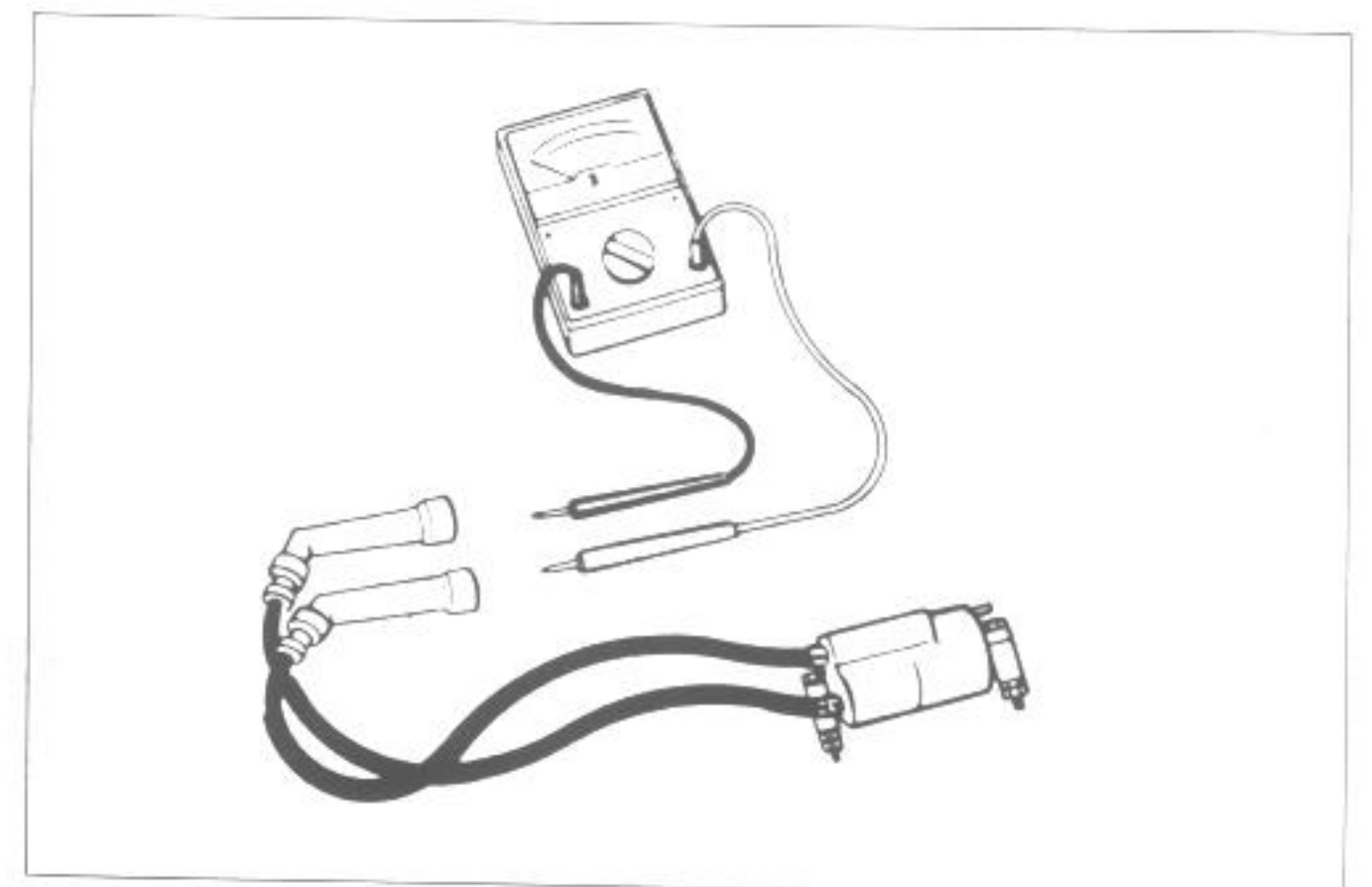

SIGNAL GENERATOR

Measure the resistance between lead wires.
 If the resistance noted shows infinity or too low a resistance value, the signal generator must be replaced.

09900-25002	Pocket tester
-------------	---------------

Standard (Y-BI, B-G) resistance	100 – 300 Ω
---------------------------------	-------------

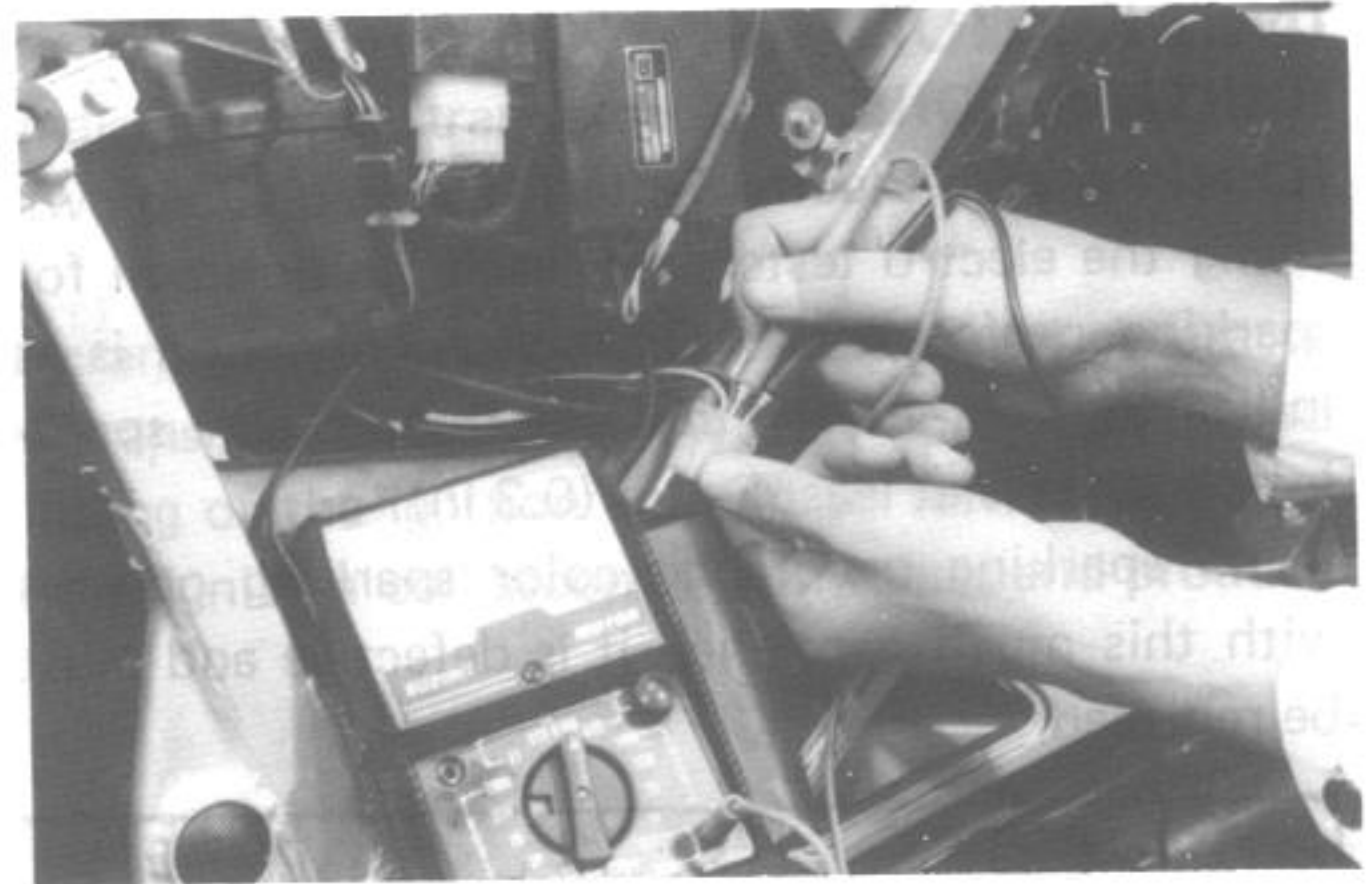

IGNITOR UNIT (TRANSISTOR UNIT)

Remove all of the spark plugs from the cylinder head, and fit to respective plug caps and place them on the cylinder head.

NOTE:
 Make sure that the spark plug gasket are removed.

Turn the starter motor and check that each spark plug sparks.
 If the ignitor unit fails this test, it must be replaced.

NOTE:
 This checking presupposes that the ignition coil and the signal generator coil used for checking are good ones.

CAUTION:
 When making this test, keep the fire away from the cylinder head.

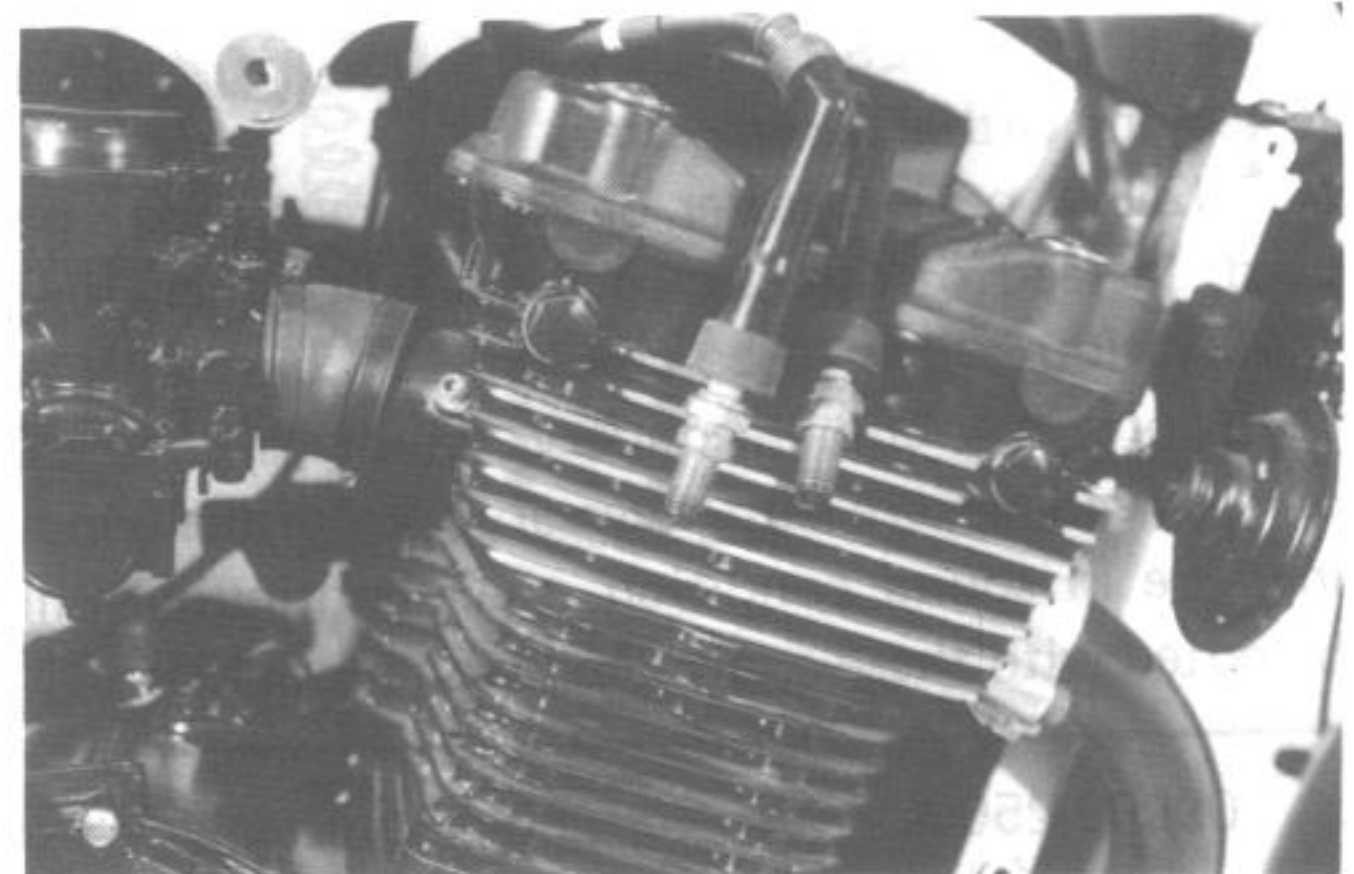
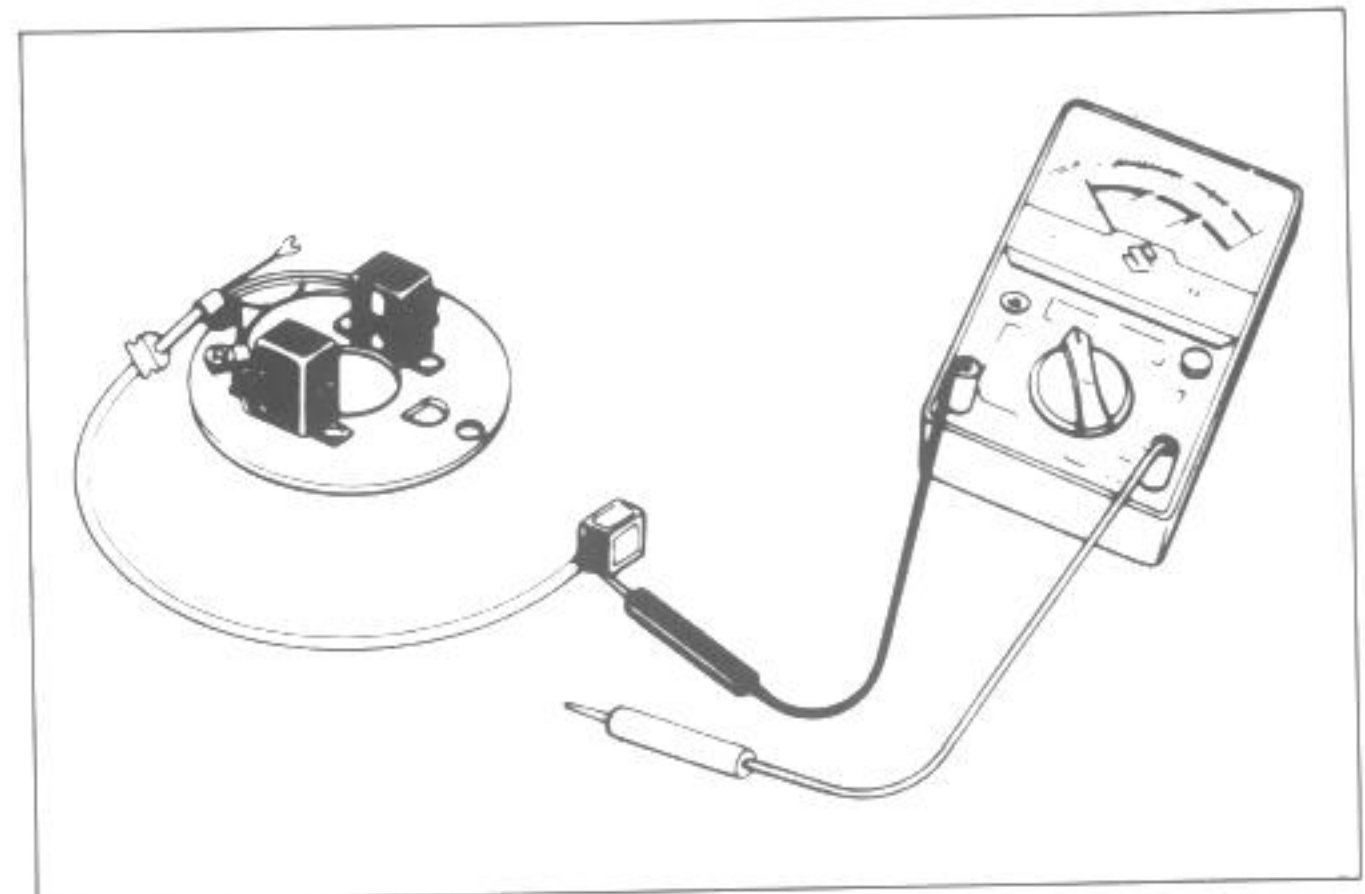

1. Set pocket tester to Ohms x 1 scale.
2. Connect pocket tester positive ⊕ lead to "Black" terminal of ignitor box.
3. Touch the pocket tester negative ⊖ lead to "Green" terminal of ignitor box.
4. When the negative lead is disconnected, spark should occur at the number 2 and 3 spark plugs.
5. Connect pocket tester positive ⊕ lead to "Yellow" terminal of ignitor box.
6. Touch the pocket tester negative lead to the "Blue" terminal of the ignitor box.
7. When the negative lead is disconnected, spark should occur at the number 1 and 4 spark plugs.

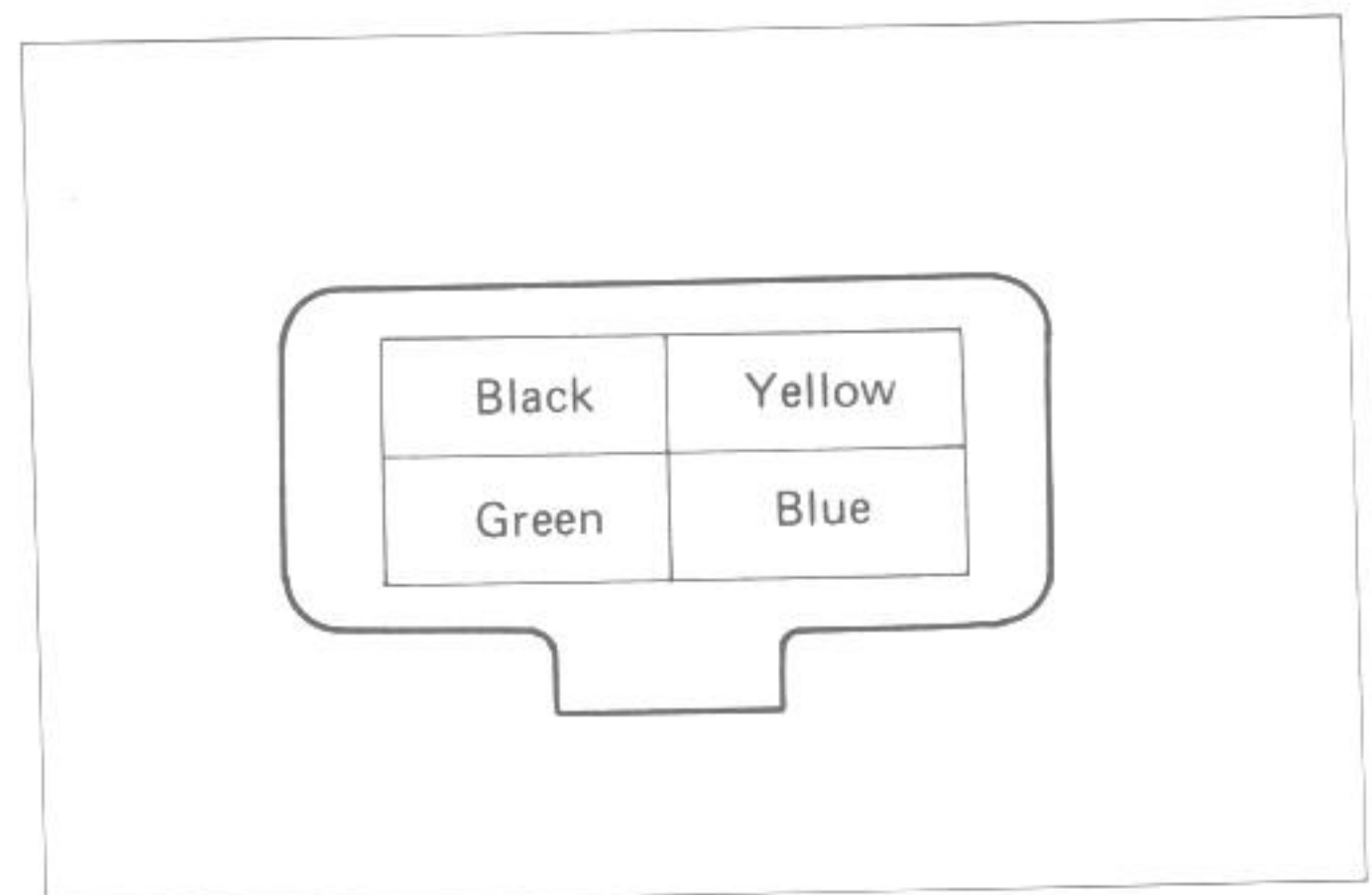

CHARGING SYSTEM

DESCRIPTION

The circuit of the charging system is indicated in figure, which is composed of an AC generator, regulator/rectifier unit and battery.

The AC current generated from AC generator is rectified by rectifier and is turned into DC current, then it charges the battery.

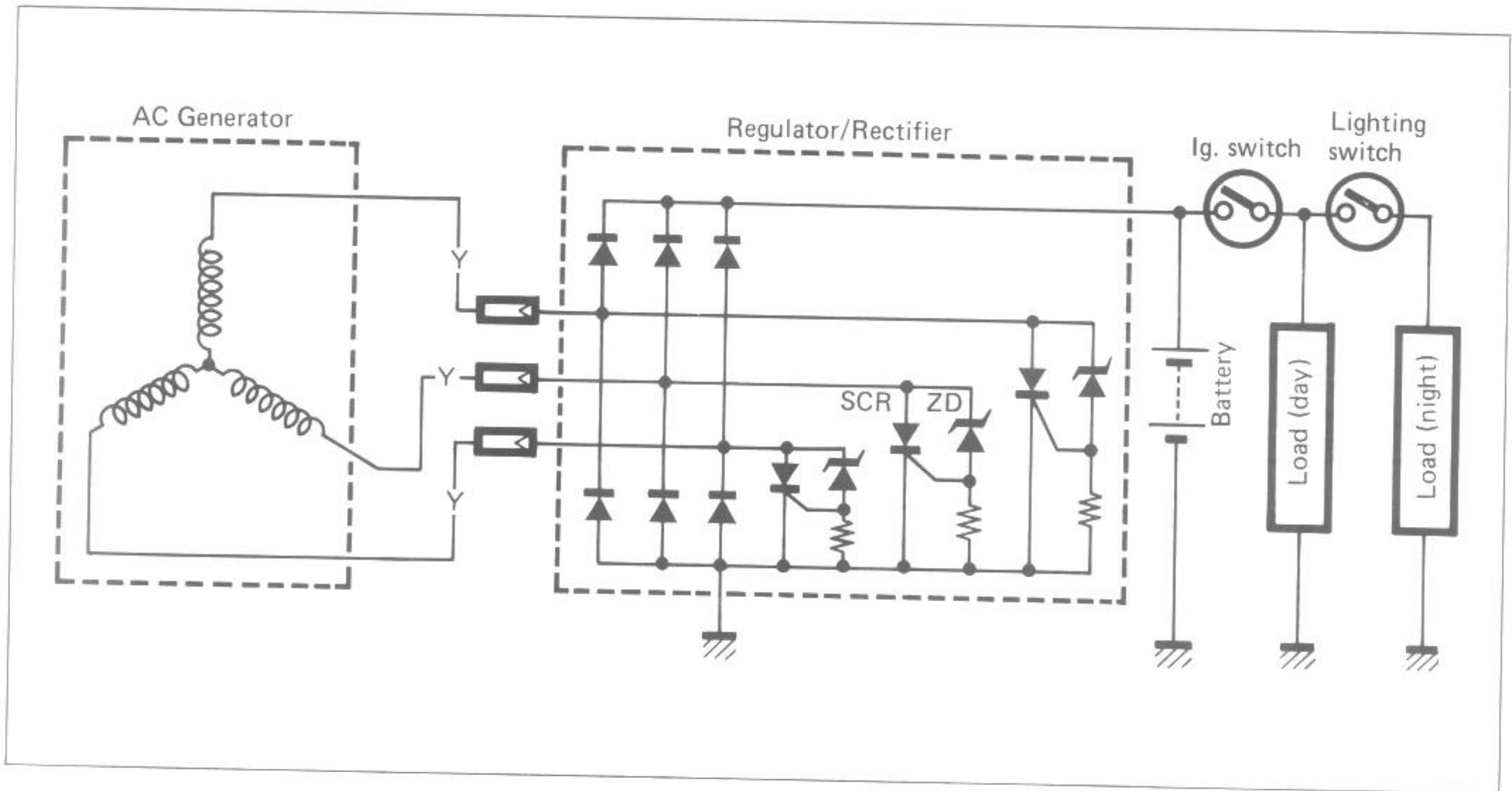

Function of Regulator

While the engine r/min is low and the generated voltage of AC generator is lower than the adjusted voltage of Regulator, the regulator does not function, incidentally the generated current charges the battery directly.

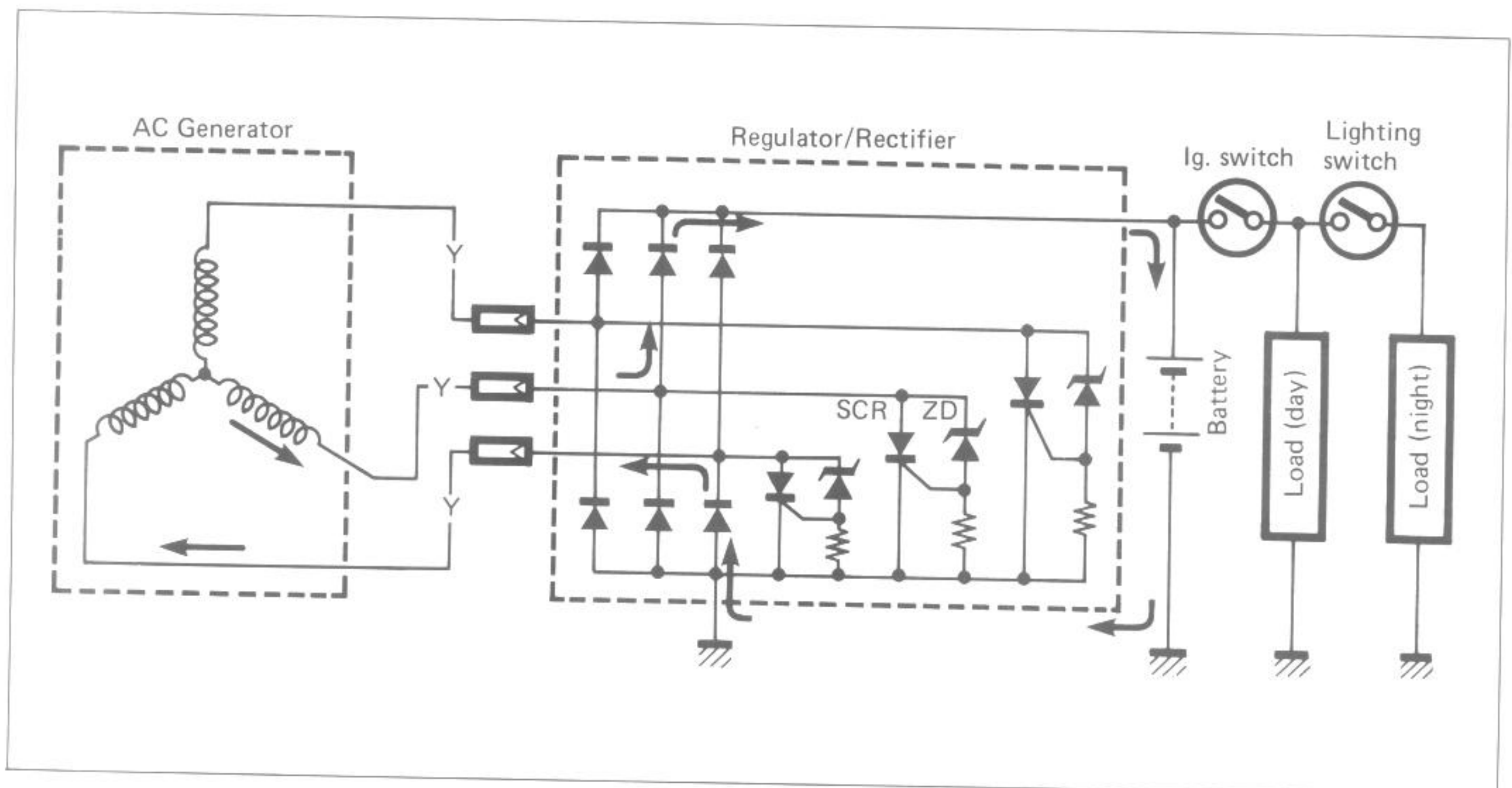

When the engine r/min becomes higher, the generated voltage of AC generator also becomes higher and the voltage between points **A** and **B** of regulator becomes high accordingly, and when it reaches the adjusted voltage of regulator, ZD (Zener diode) becomes "ON" condition and, signal will be sent to the SCR (Thyristor) gate probe and SCR will become "ON" condition.

Then the SCR becomes conductive to the direction from point **C** to point **D**. Namely at the state of this, the current generated from the AC generator gets through SCR without charging the battery and returns to AC generator again. At the end of this state, since the AC current generated from AC generator flows into the point **D**, reverse current tends to flow to SCR, then the circuit of SCR turns to OFF mode and begins to charge the battery again. Thus these repetitions maintain charging voltage to the battery constant and protect it from overcharging.

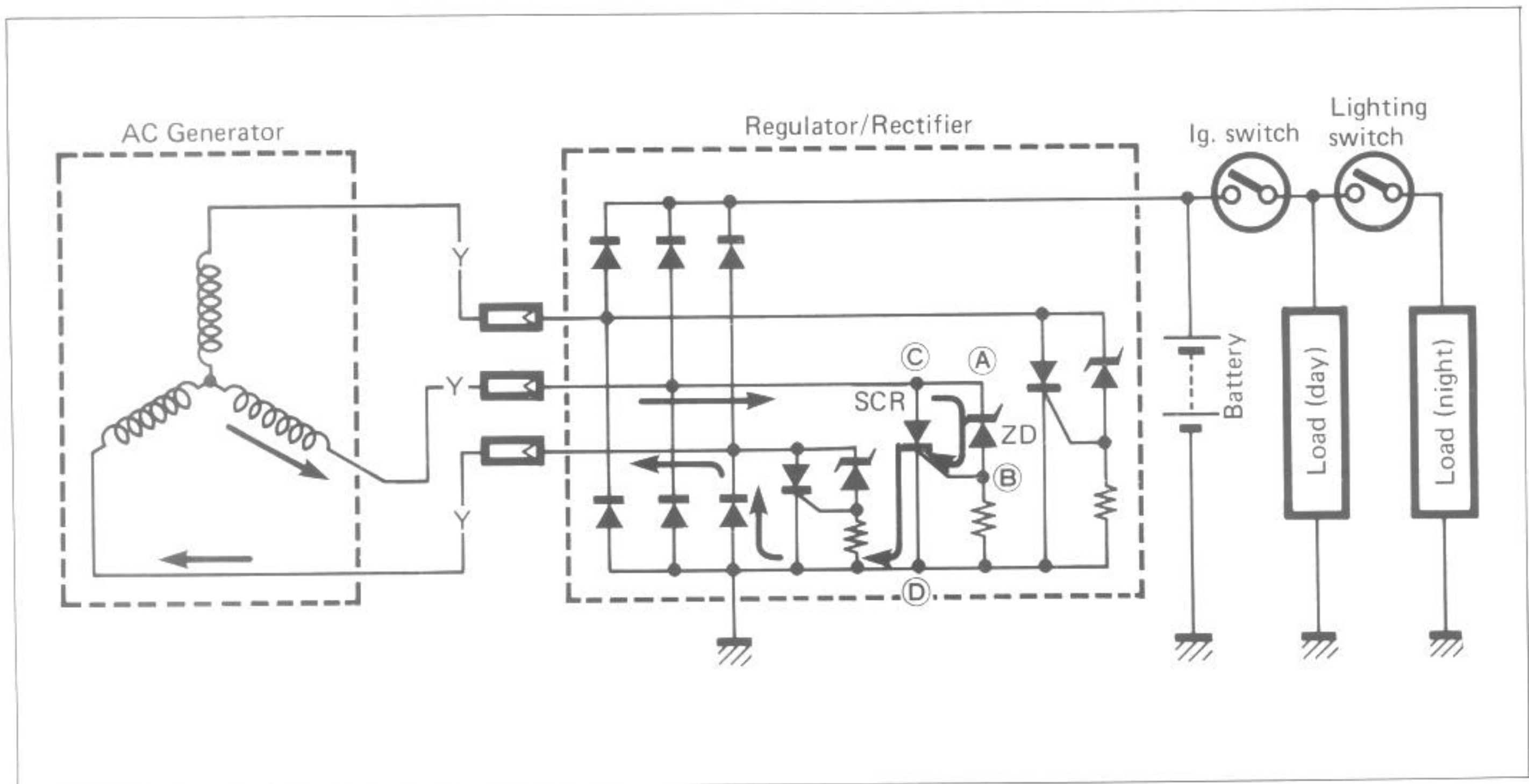

INSPECTION**CHARGING OUTPUT CHECK**

Start the engine and keep it running at 5 000 r/min with the lighting switch turned ON (High position).

Using the pocket tester, measure the DC voltage between the starter relay ⊕ terminal and ground. If the tester reads under 14.0V or over 15.5V, the regulator/rectifier is faulty.

NOTE:

When making this test, be sure that the battery is in fully-charged condition.

STD charging output	14.0 – 15.5V (DC) at 5 000 r/min
09900-25002	Pocket tester

AC GENERATOR NO-LOAD PERFORMANCE

Disconnect the three lead wires from the AC generator terminal.

Start the engine and keep it running at 5 000 r/min.

Using the pocket tester, measure the AC voltage between the three lead wires.

If the tester reads under 80V, the AC generator is faulty.

STD No-load performance	80V (AC) or over at 5 000 r/min
-------------------------	------------------------------------

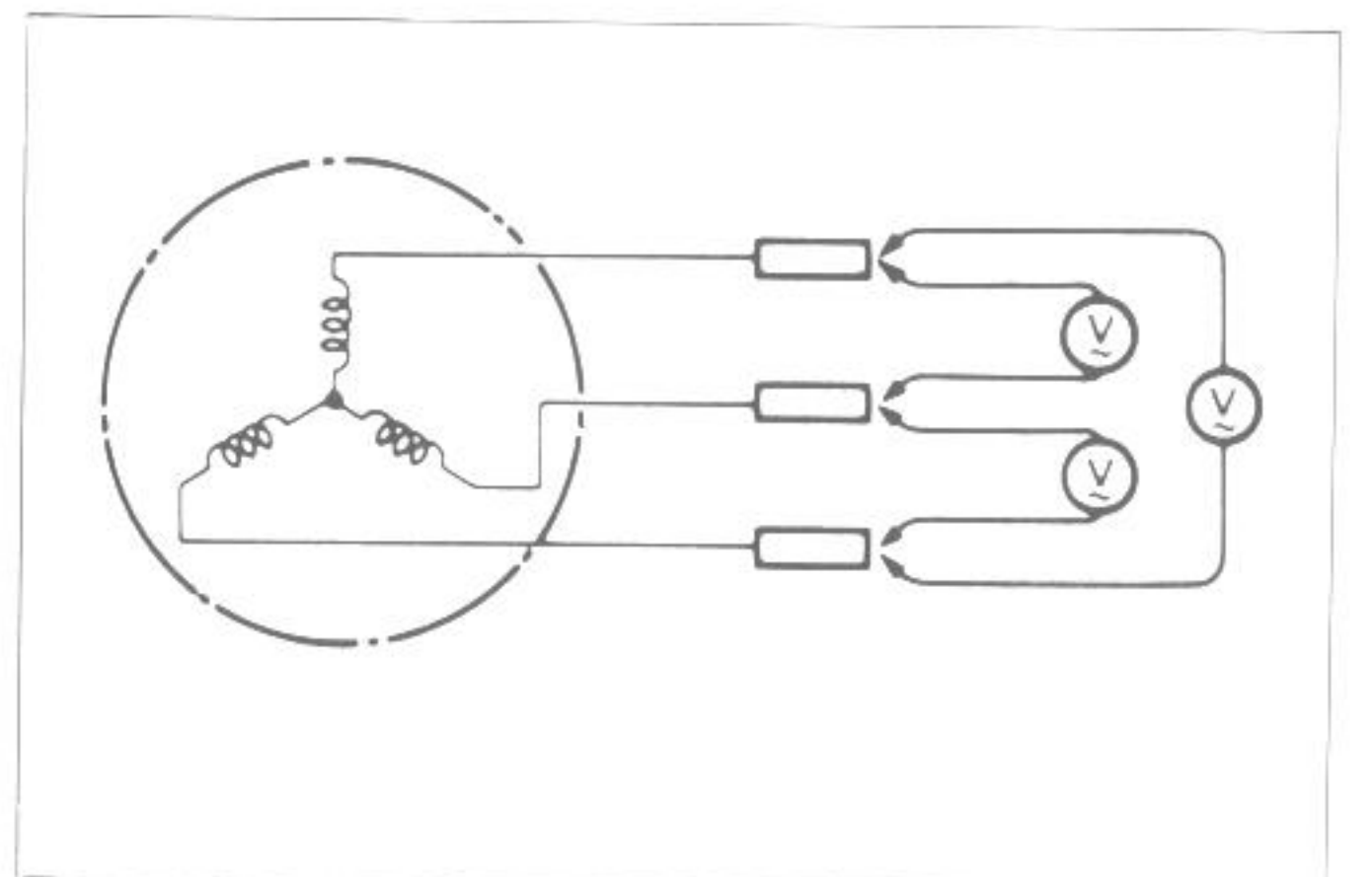
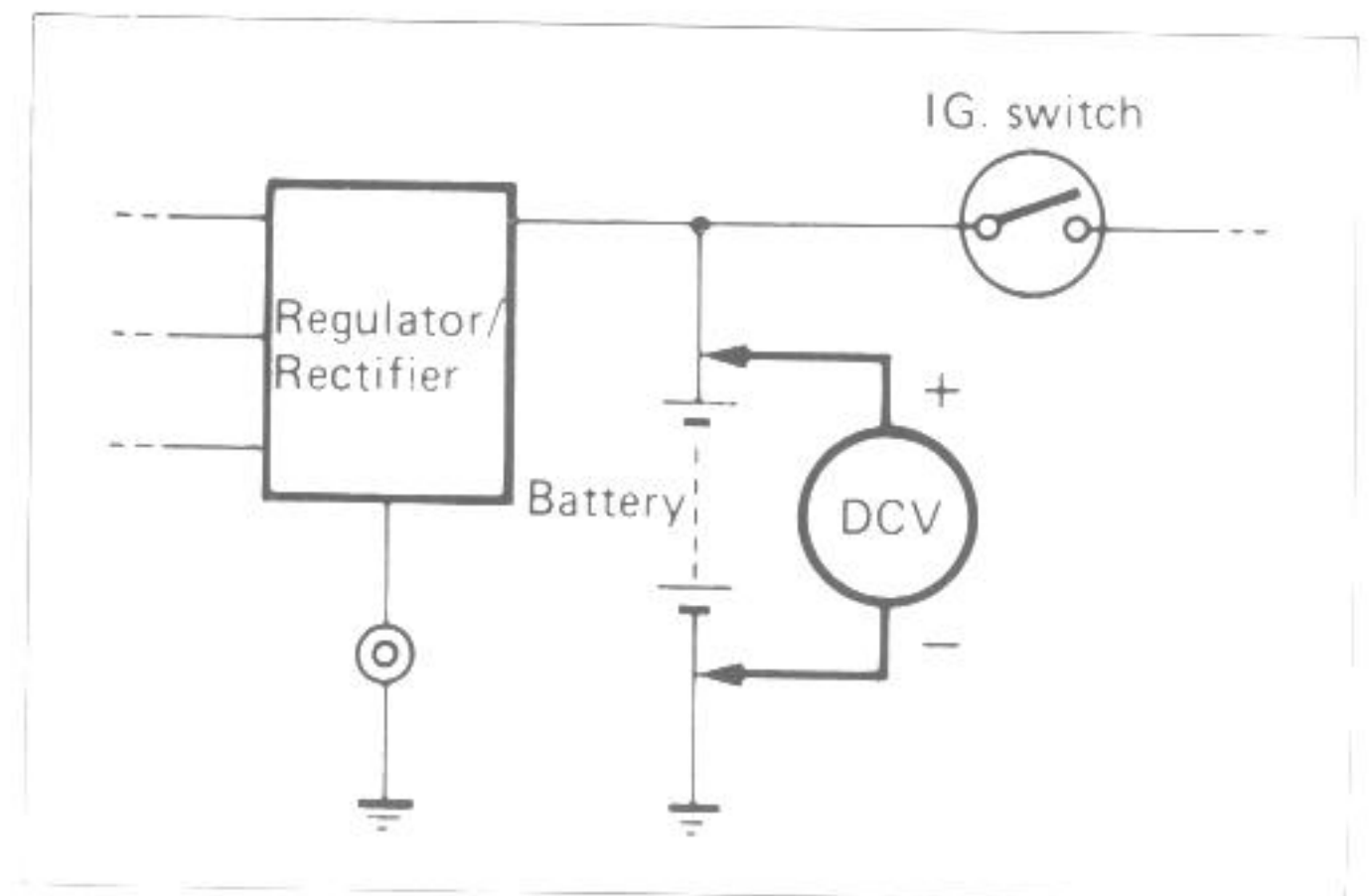

AC GENERATOR STATOR COIL

Using the pocket tester, check the continuity between the lead wires of the stator.

Also check that the stator core is insulated.

NOTE:

When making this test, it is not necessary to remove the AC generator.

09900-25002	Pocket tester
-------------	---------------

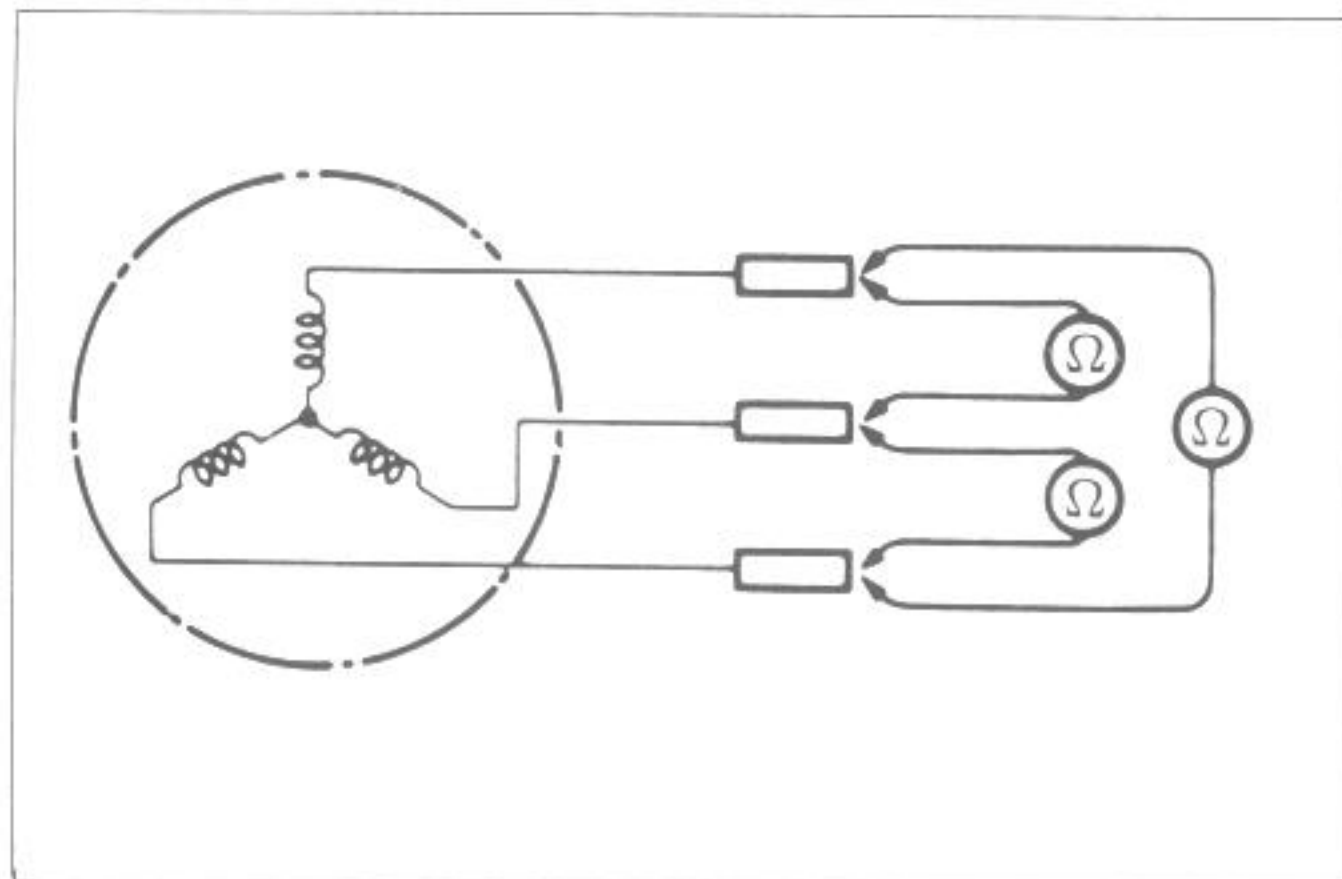

REGULATOR/RECTIFIER

Using the pocket tester, measure the resistance between the read wires in the following table. If the reading is incorrect, replace the regulator/rectifier.

CAUTION:

As SCR and diodes are used inside this regulator/rectifier unit, the resistance values will differ when an ohmmeter other than SUZUKI pocket tester is used.

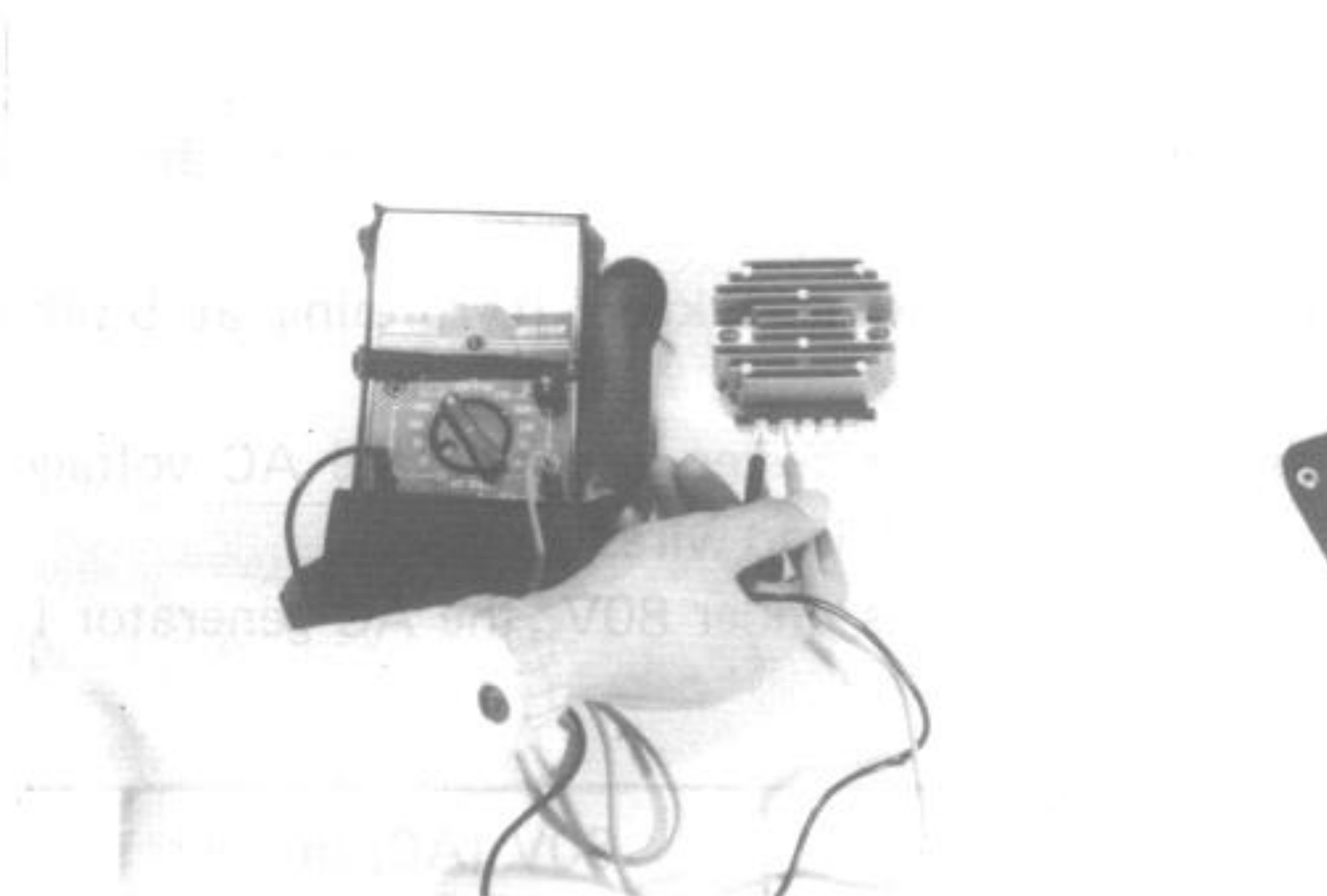

Tester range: X1Ω

Unit: Ω

		⊕ probe of tester to:				
		R	Y	Y	Y	B/W
⊖ probe of tester to:	R	∞	∞	∞	∞	∞
	Y	5-10		∞	∞	∞
	Y	5-10	∞		∞	∞
	Y	5-10	∞	∞		∞
	B/W	50-200	5-10	5-10	5-10	

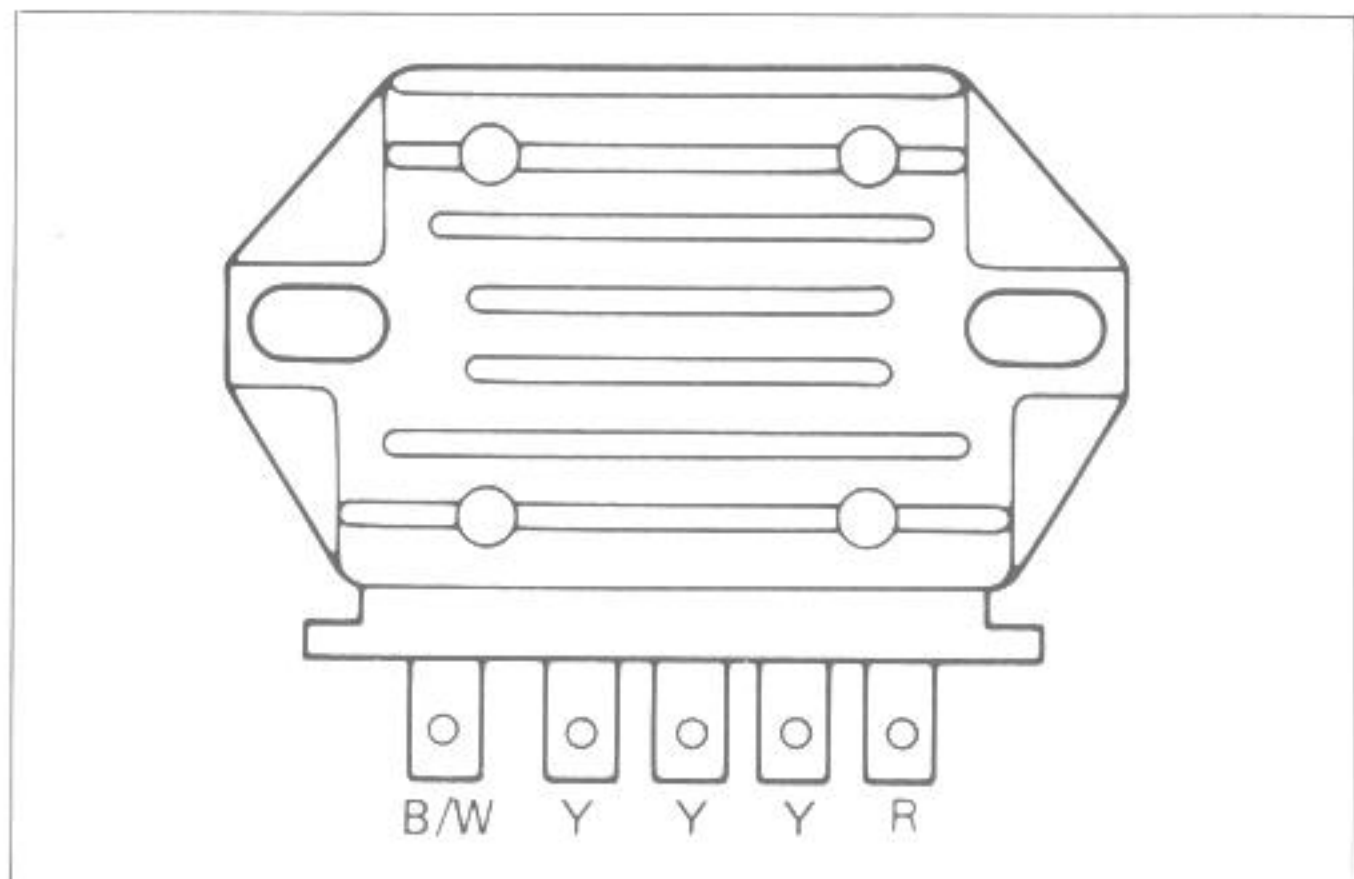

STARTER SYSTEM

DISCRIPTION

The starter system is operated by starter motor, starter relay, starter button, engine kill switch, ignition switch and battery. The diagram below shows the electrical circuit of the system.

When the starter switch is "ON", the plunger is forced to link the main contact points of the relay by the magnetic power of the pull-in coil.

The current from the battery now flows to the starter motor through these connected points, and next the starter motor makes the engine start to run.

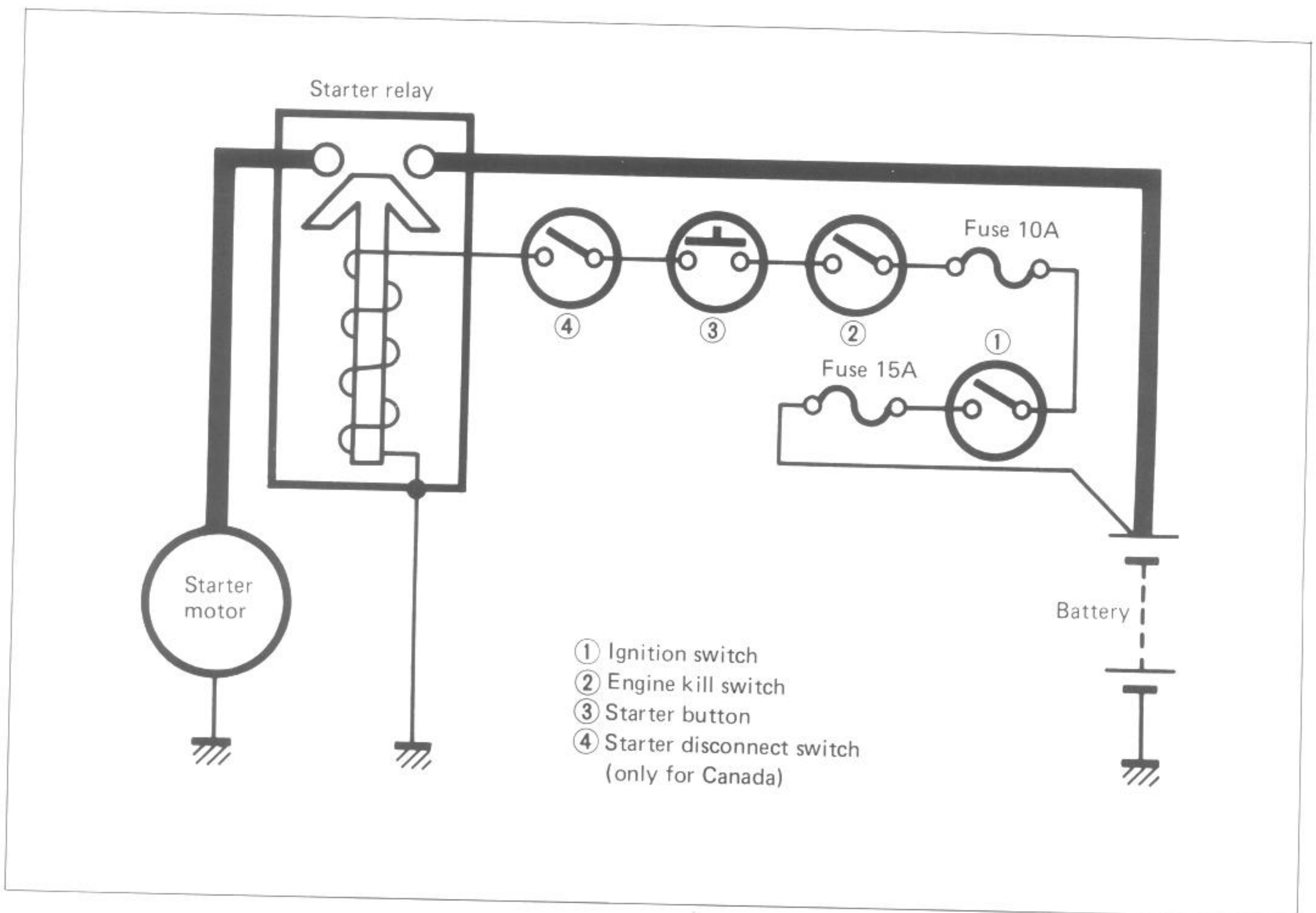

DISASSEMBLY

STARTER MOTOR CONSTRUCTION

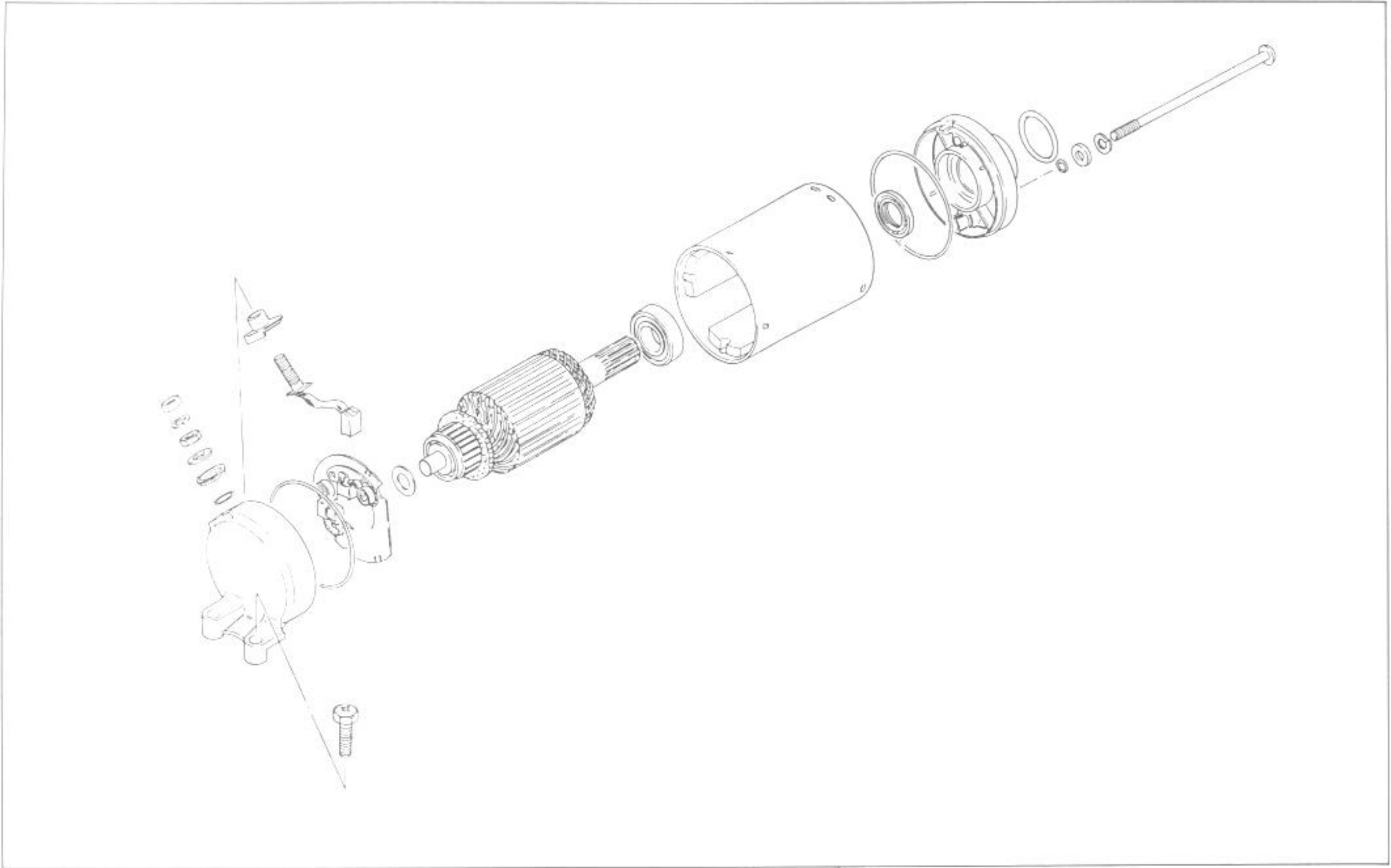

INSPECTION

CARBON BRUSHES

When the brushes are worn, the motor will be unable to produce sufficient torque, and the engine will be difficult to turn over. To prevent this, periodically inspect the length of the brushes, replacing them when they are too short or chipping.

Service Limit	9 mm (0.4 in)
---------------	---------------

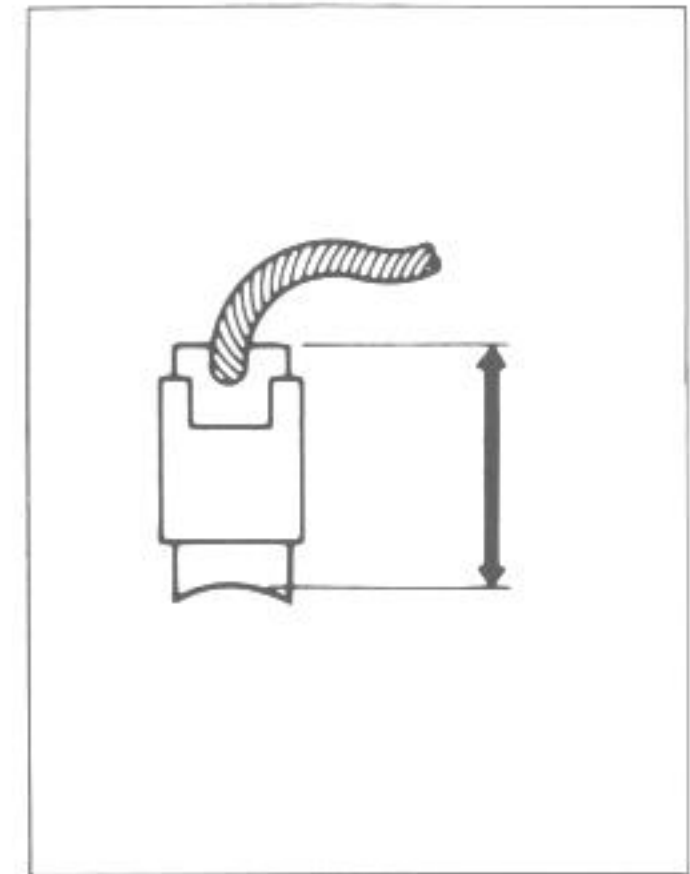
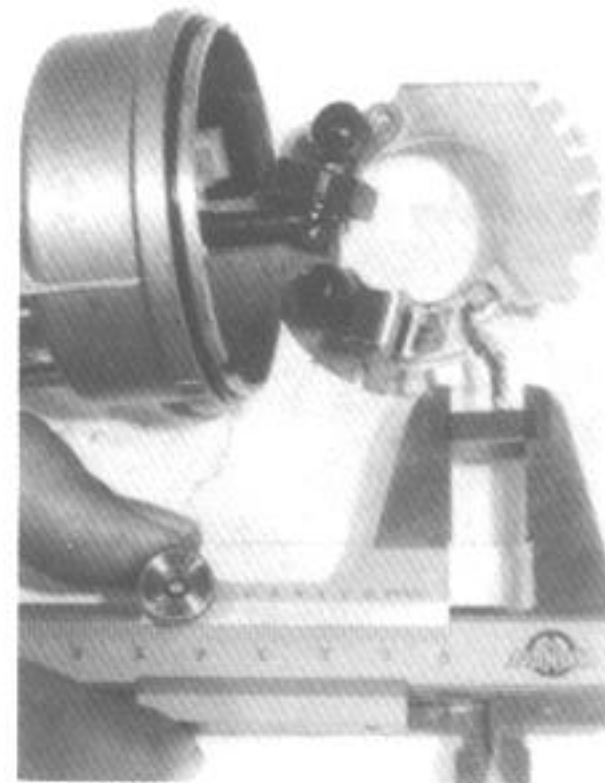

COMMUTATOR

If the commutator surface is dirty, starting performance decreases. Polish the commutator with #400 or similar fine emery paper when it is dirty. After polishing, wipe the commutator with a clean dry cloth.

Measure the commutator under-cut ①.

Service Limit	0.2 mm (0.008 in)
---------------	-------------------

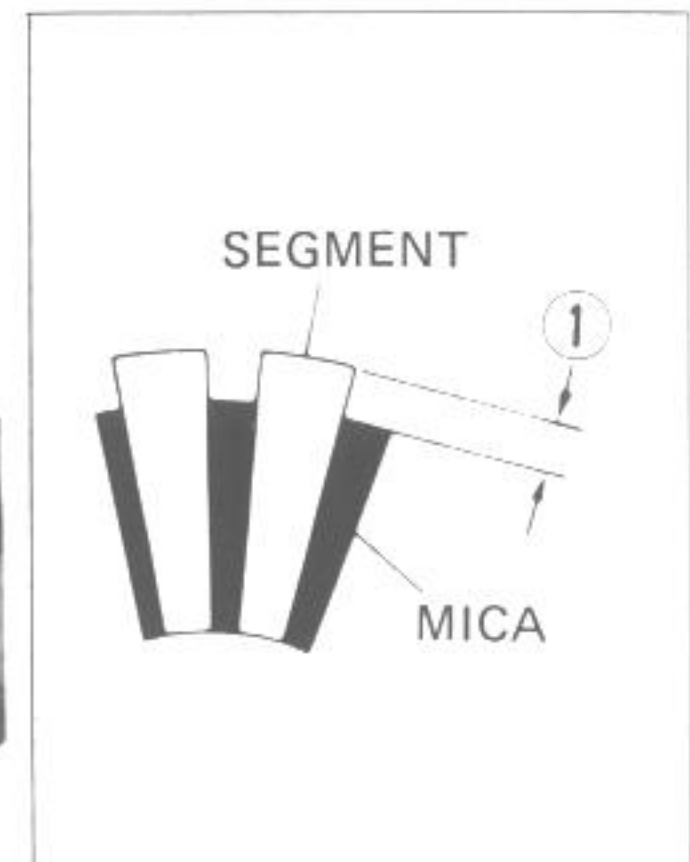
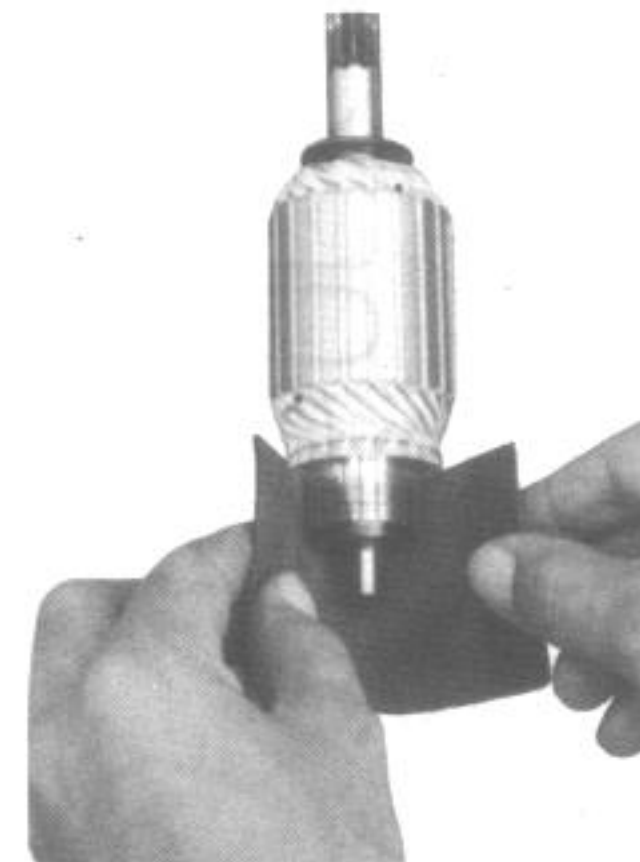

ARMATURE COIL

Using a pocket tester, check the coil for open and ground by placing probe pins on each commutator segment and rotor core (to test for ground) and on any two segments at various places (to test for open), with the brushes lifted off the commutator surface.

If the coil is found to be open-circuited or grounded, replace the armature. Continuous use of a defective armature will cause the starter motor to suddenly fail.

09900-25002	Pocket tester
-------------	---------------

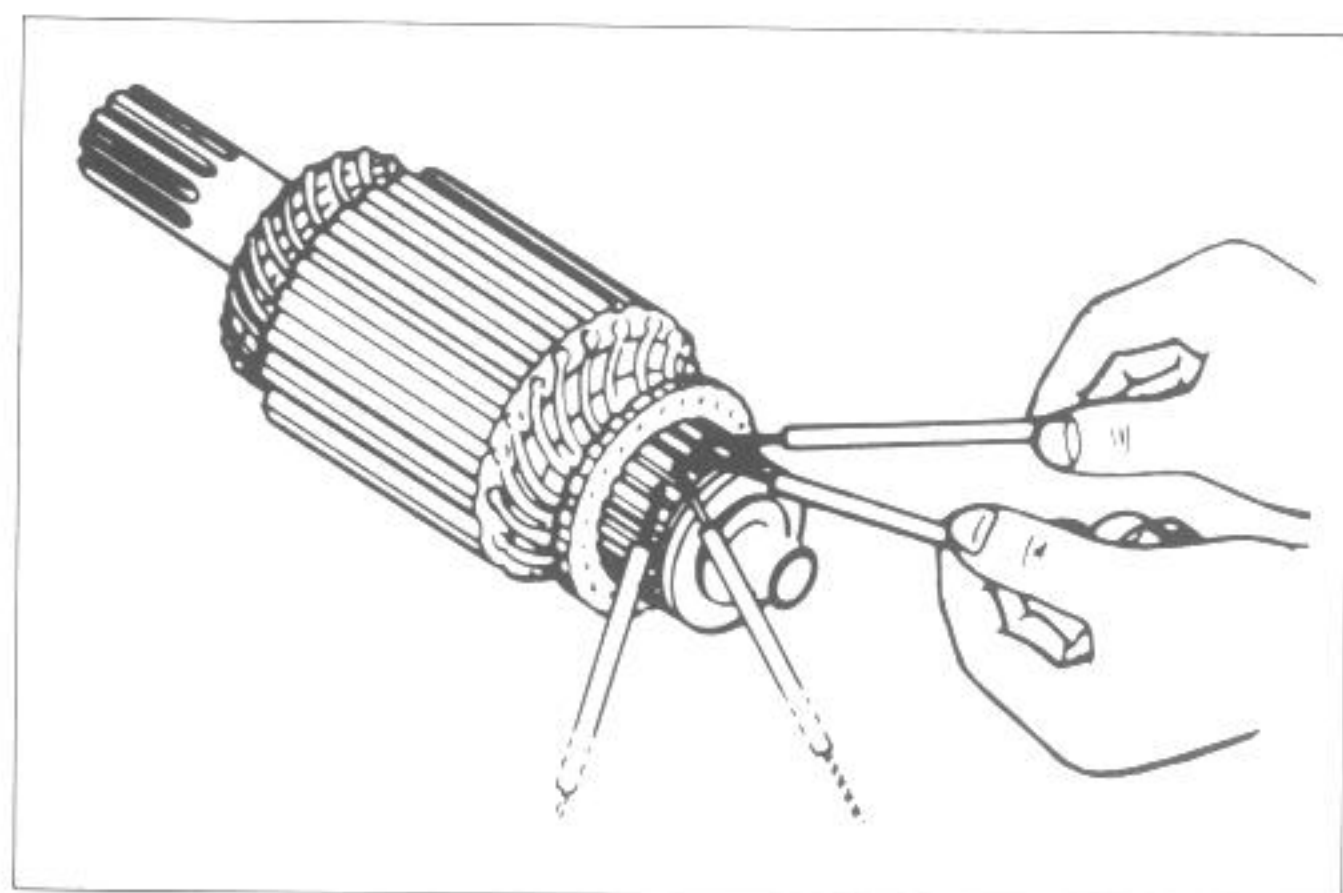
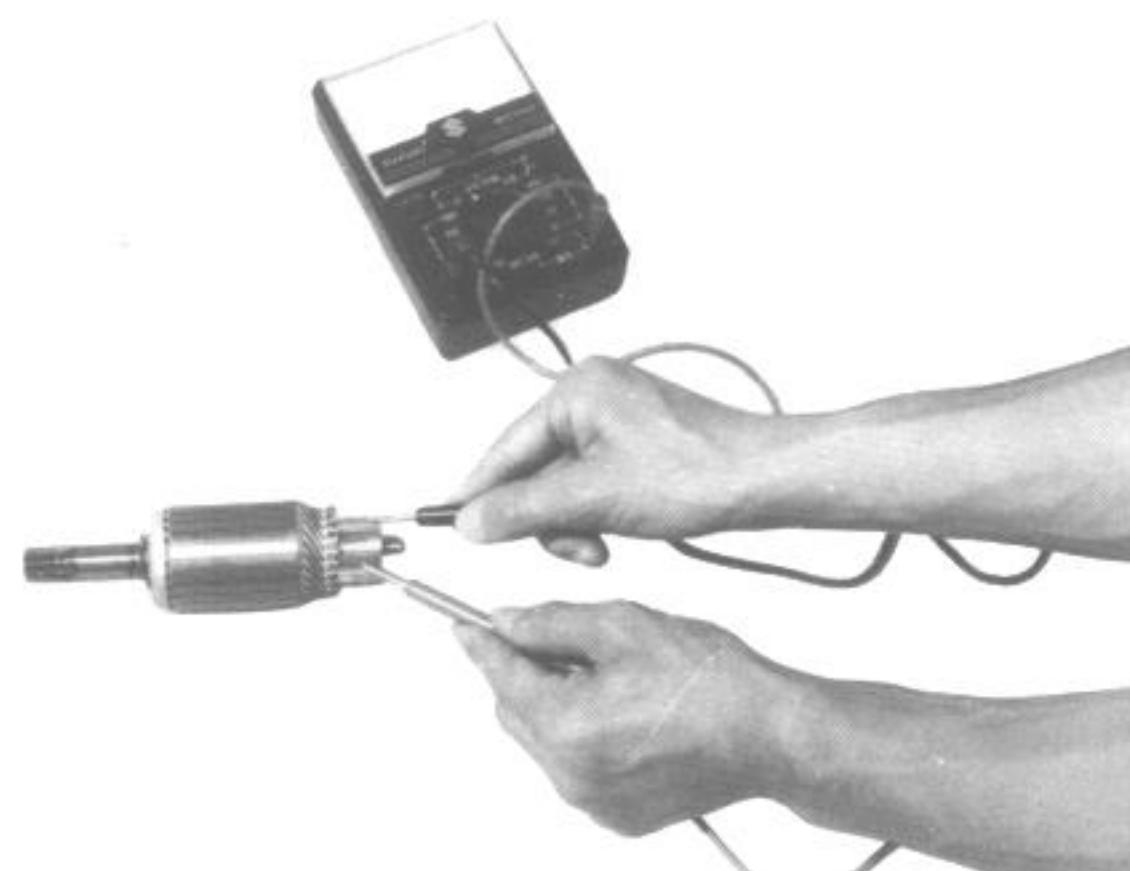

STARTER RELAY

Disconnect lead wire of the starter motor at starter relay.

CAUTION:

When disconnecting ground lead wire from the starter relay, do not touch the wrench to the positive terminal of the starter relay.

Turn on the ignition switch, inspect the continuity between the terminals, positive and negative, when pushing the starter button.

If the starter relay is in sound condition, continuity is found.

Check the coil for "open", "ground" and ohmic resistance. The coil is in good condition if the resistance is as follows.

STD resistance	3 – 7Ω
----------------	--------

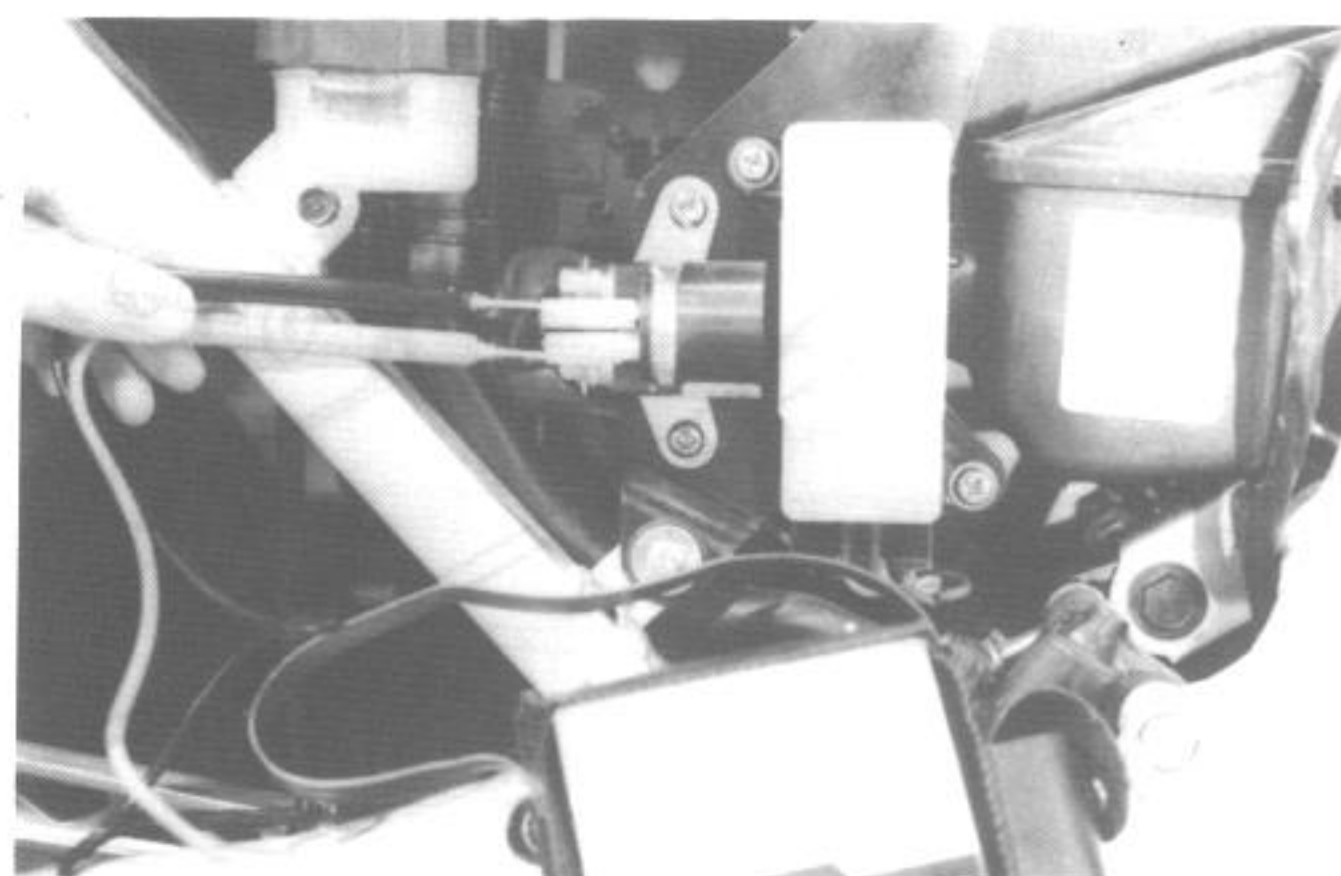
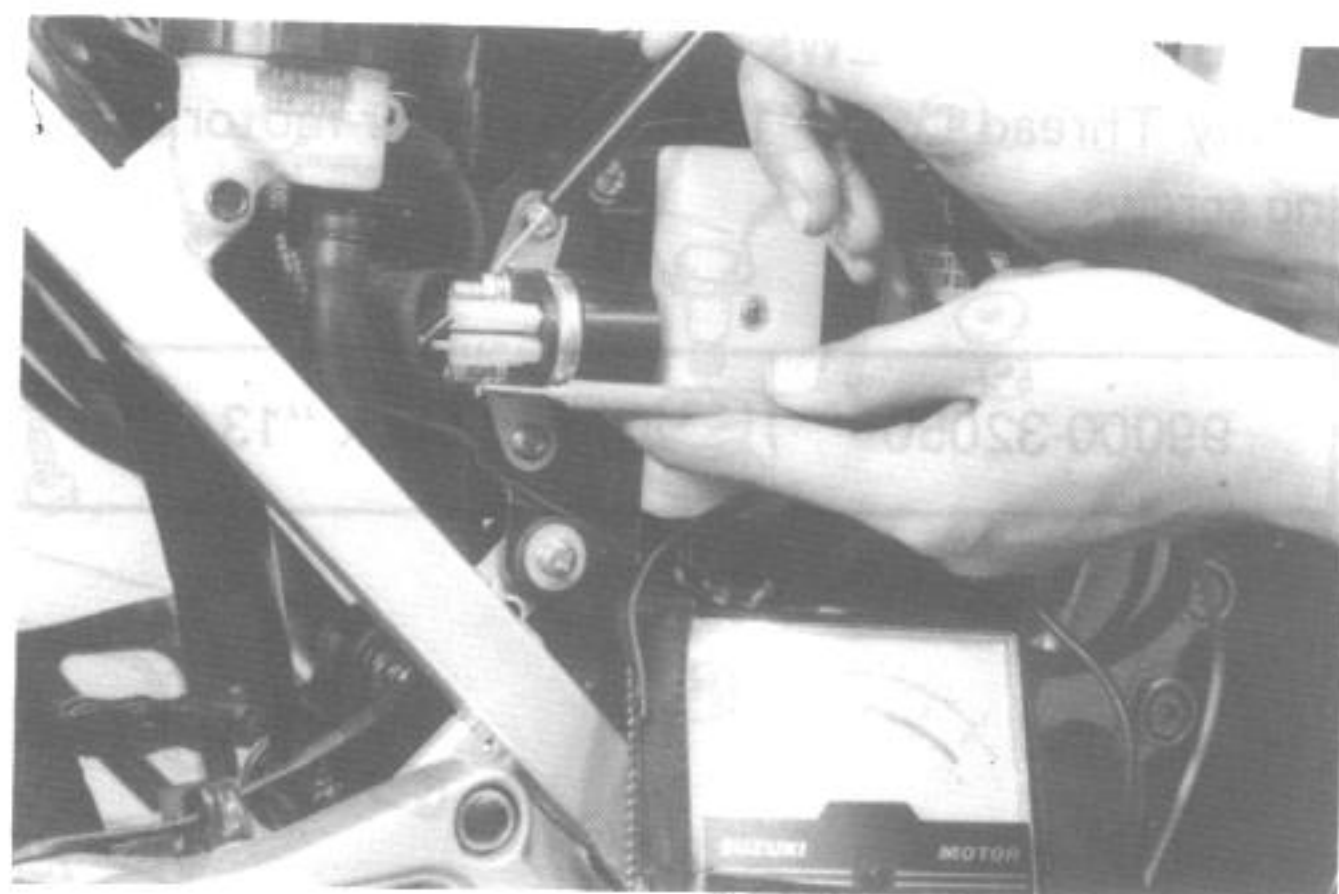

REASSEMBLY BRUSH HOLDER

When fixing brush holder to starter motor case, align the dent ① of the starter motor case with the groove ② of the brush holder.

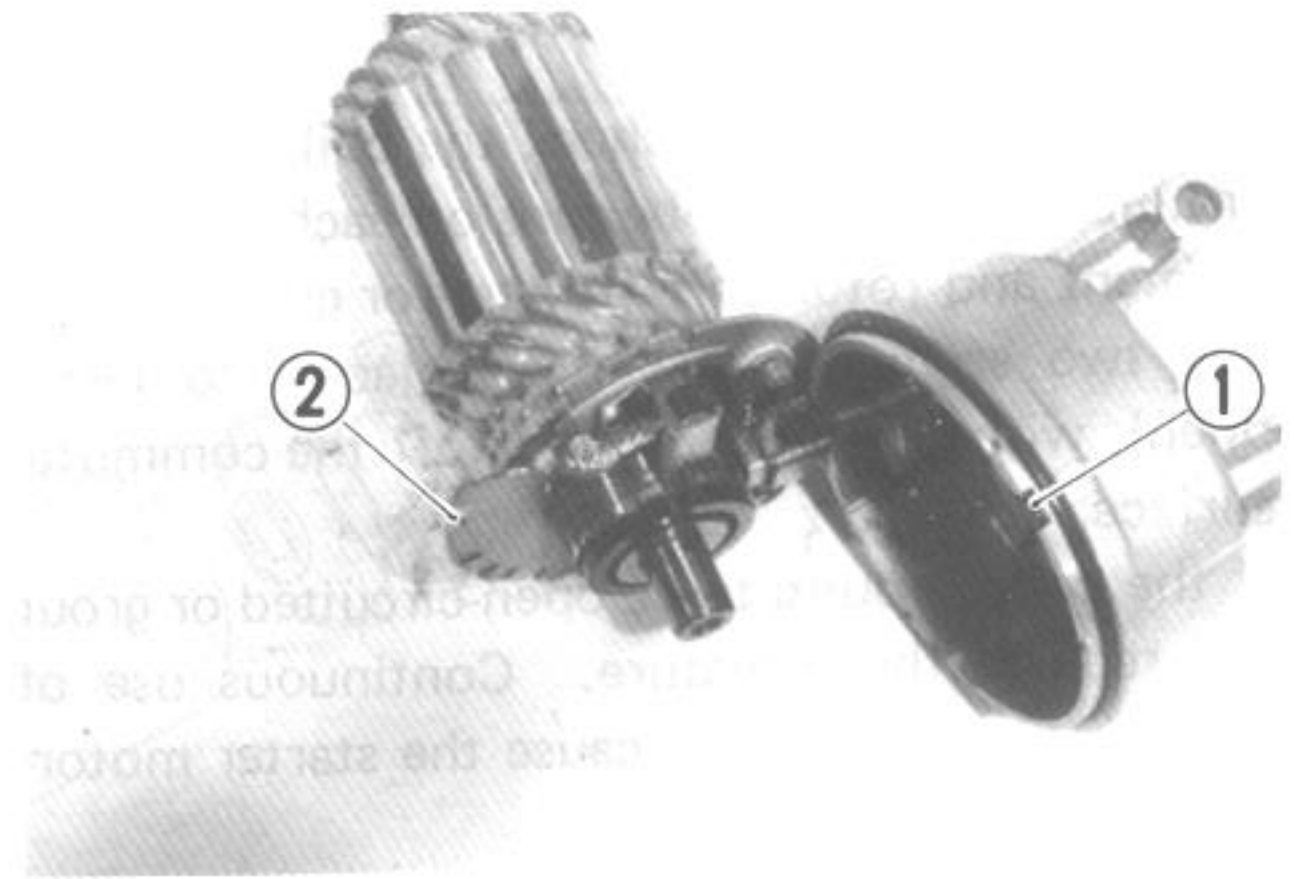

HOUSING END

When installing housing end, fix the dent ③ of the brush holder to the groove ④ on the housing end.

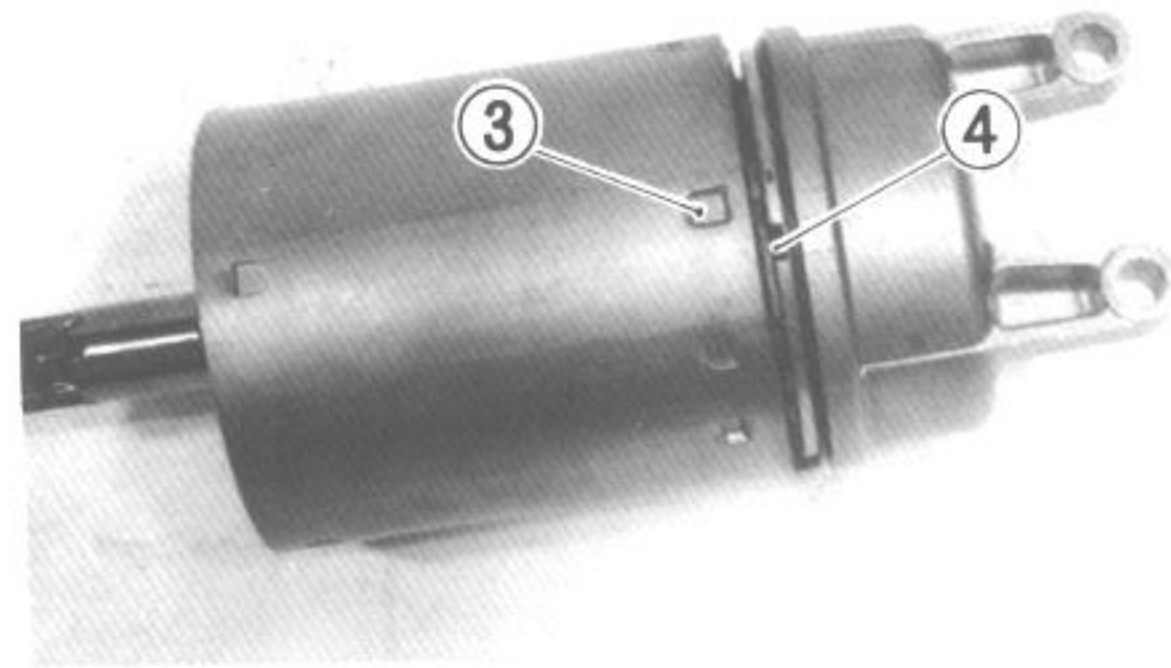

SECURING SCREWS

Apply Thread Lock "1342" to starter motor securing screws.



99000-32050

Thread Lock "1342"

COMBINATION METER

DISASSEMBLY

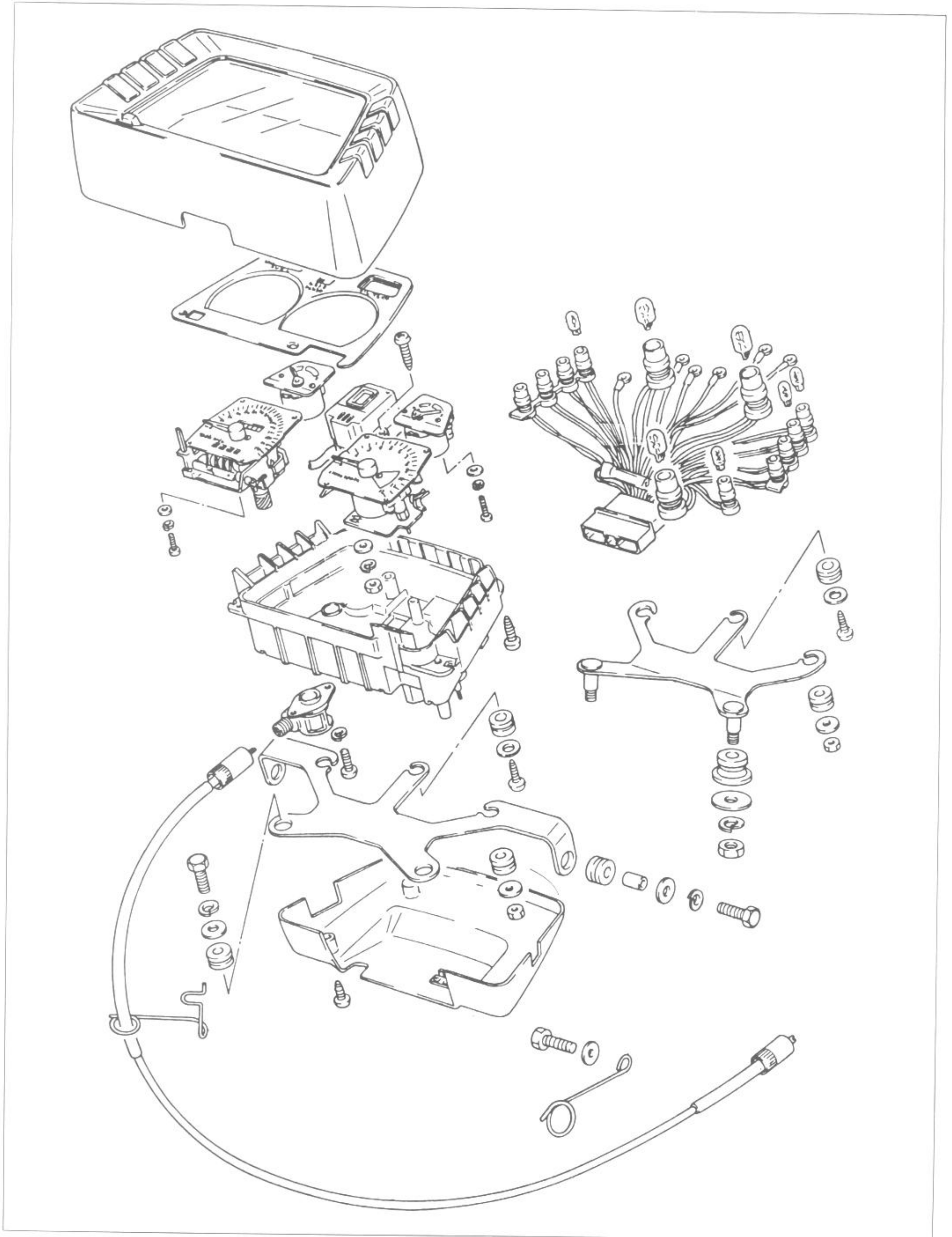

DISASSEMBLY

**INSPECTION
DIAGRAM**

- P : Oil pressure indicator
- BAT : Battery solution level indicator
- SIDE : Side stand indicator
- HL : Headlight bulb indicator
- STL : Tail/Brake light bulb indicator
- N : Neutral indicator
- B : High beam indicator

For E22

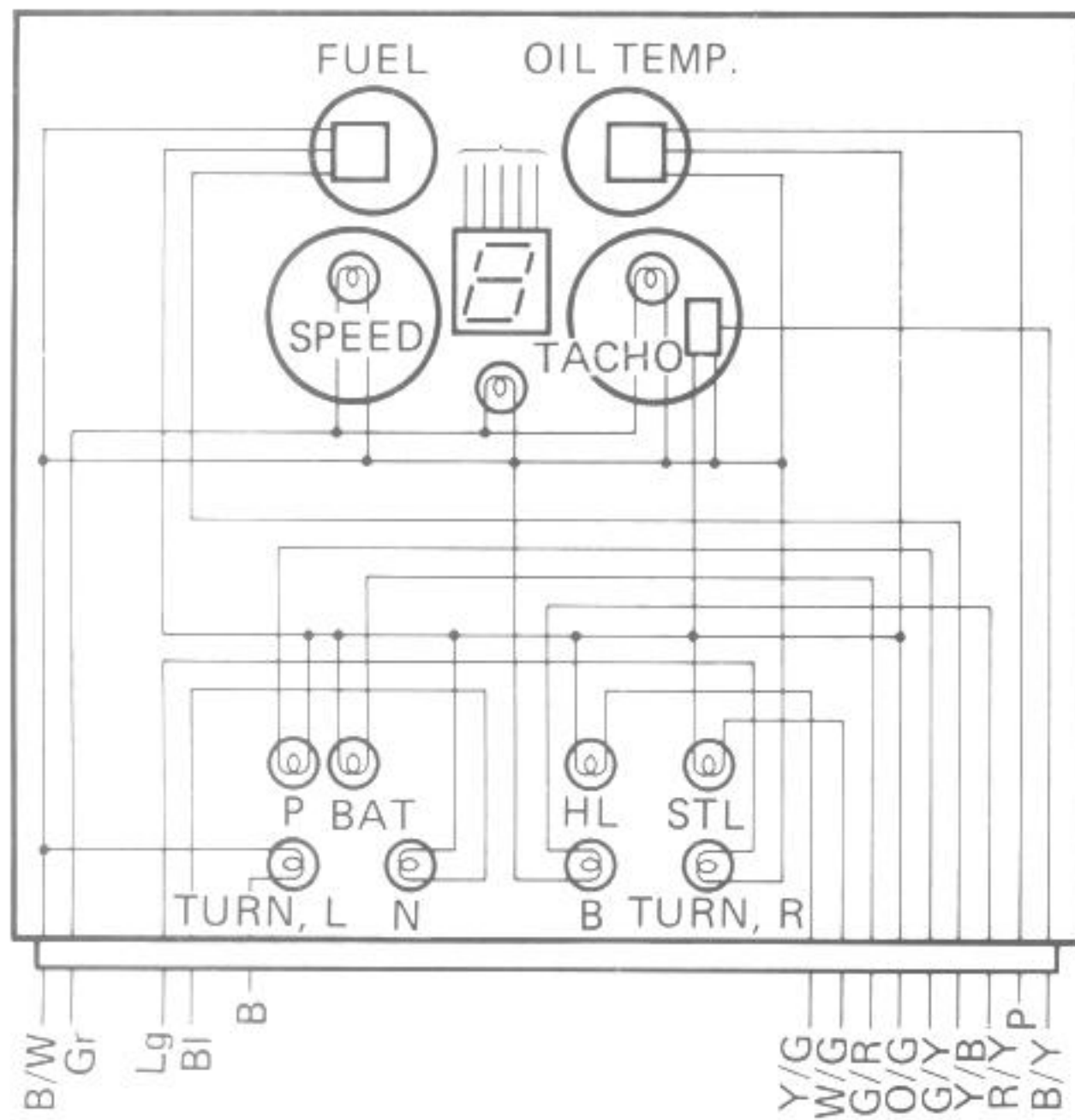

For the others

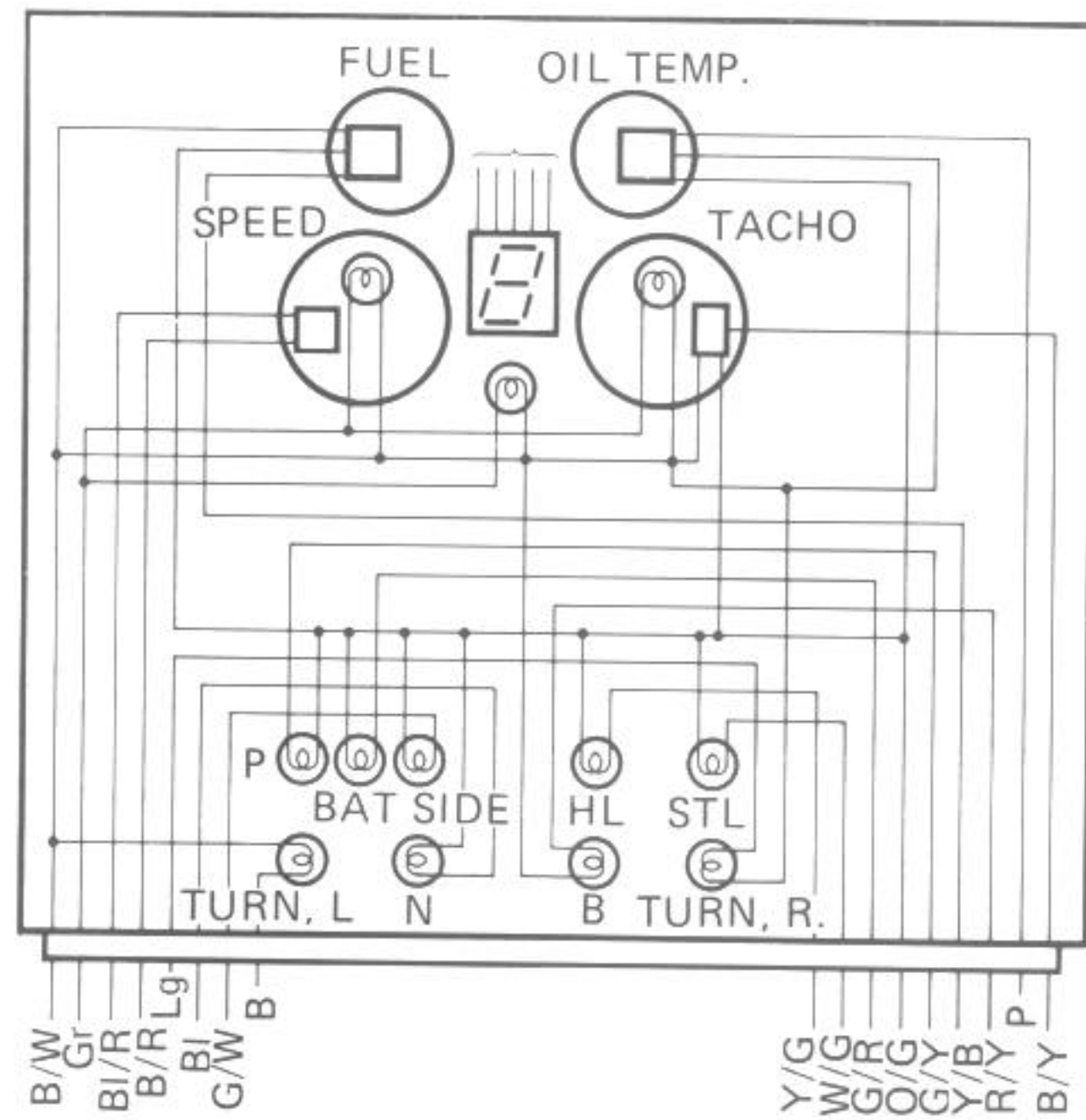

Using the pocket tester, check the continuity between lead wires in the above diagram. If the continuity measured is incorrect, replace the respective part.

09900-25002	Pocket tester
-------------	---------------

NOTE:
When making this test, it is necessary to remove the combination meter.

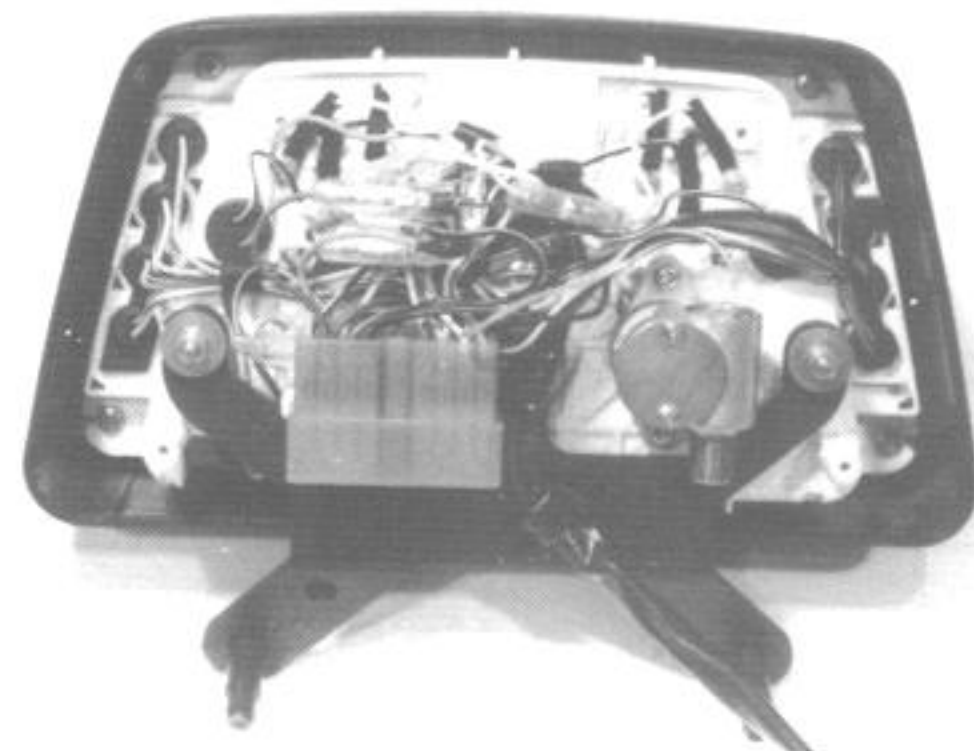

COIL TYPE FUEL GAUGE

As shown in Fig. 1, four coils are located in the fuel gauge (N_1 , N_2 , N_3 and N_4). As the resistance from the sending unit varies along with the fuel level, the current at points L_1 and L_2 will also vary. This in turn will cause the strength of the magnetic field generated in the four coils to increase or decrease (causing a related increase or decrease in the force vector H in Fig. 2) which will force the needle to move to the proper position (Fig. 3).

When the ignition is turned off, the pointer remains in the position where it was when the switch was ON. This function is displayed by using high-viscosity oil and a balanced magnet (Fig. 4).

FUEL LEVEL SYSTEM

The Fuel System can be divided into two sections:

- (1) The Fuel Meter : Located in the instrument cluster
- (2) The Fuel Tank Float Assembly (Fuel gauge sending unit)

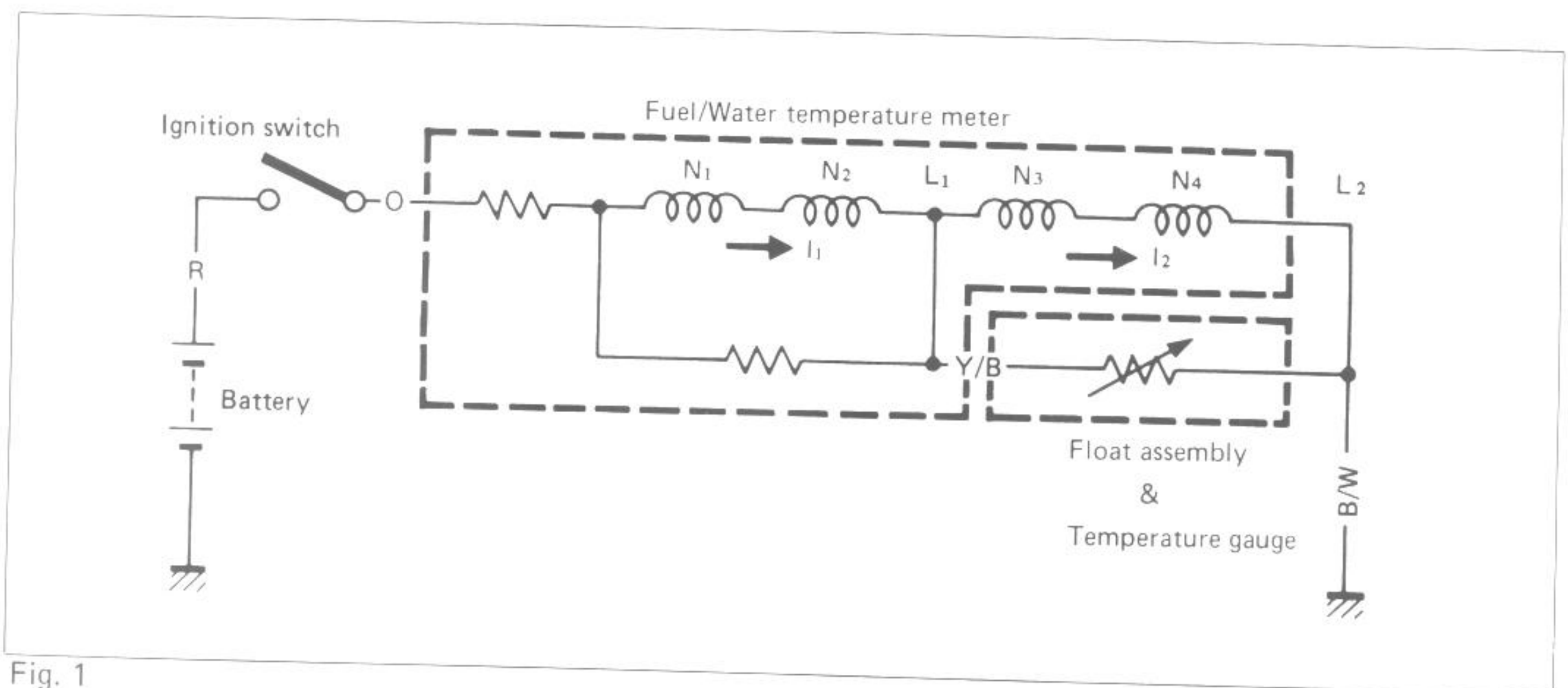

Fig. 1

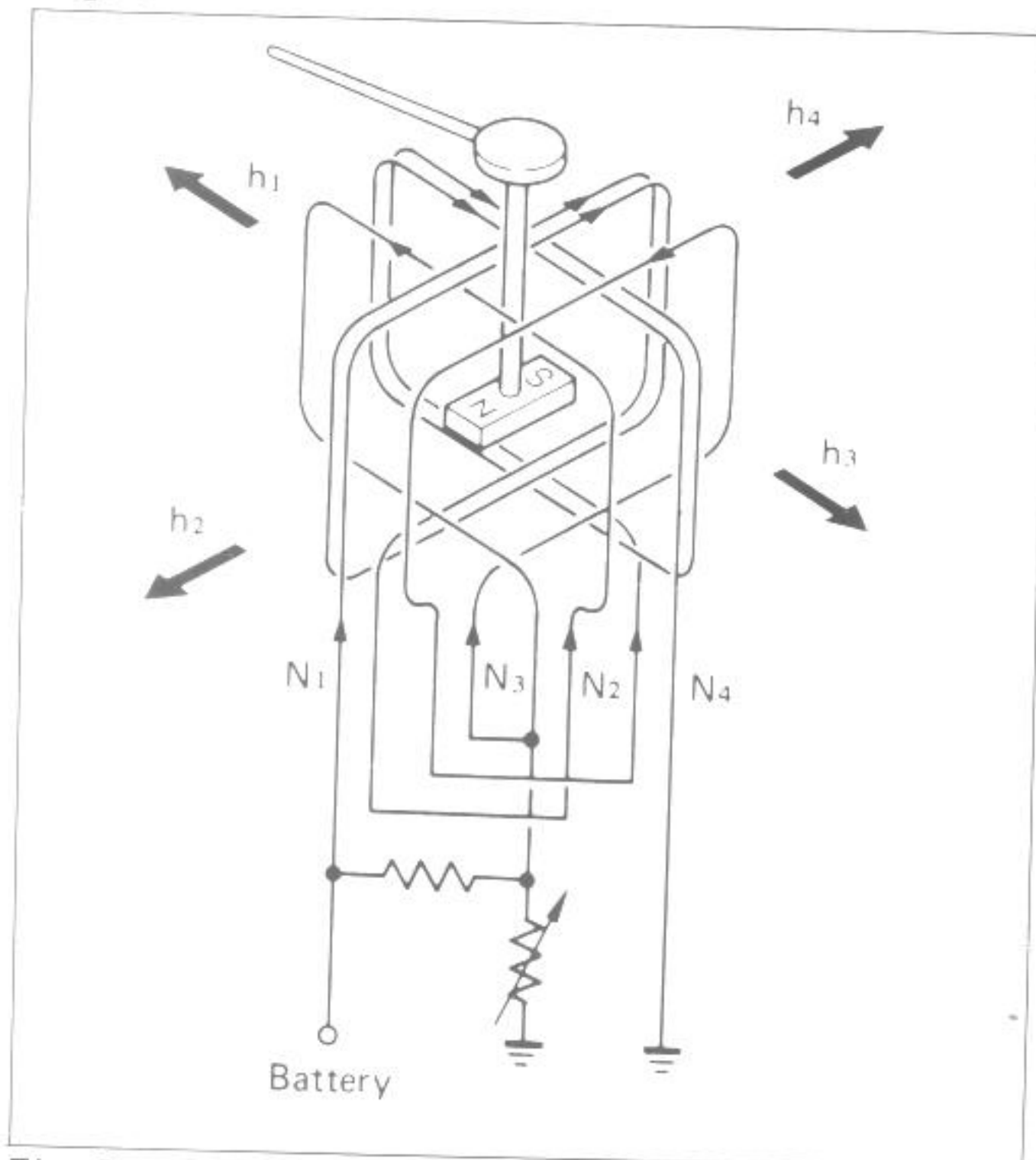

Fig. 3

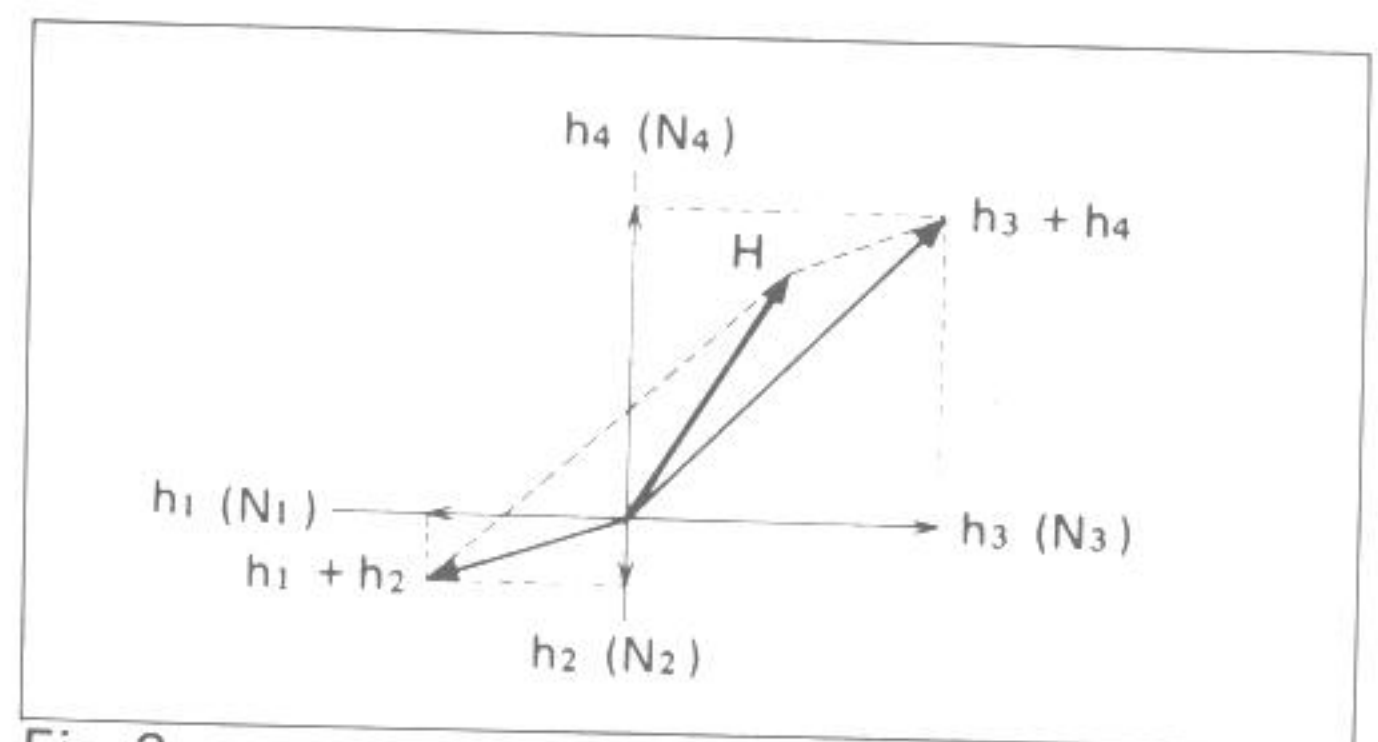

Fig. 2

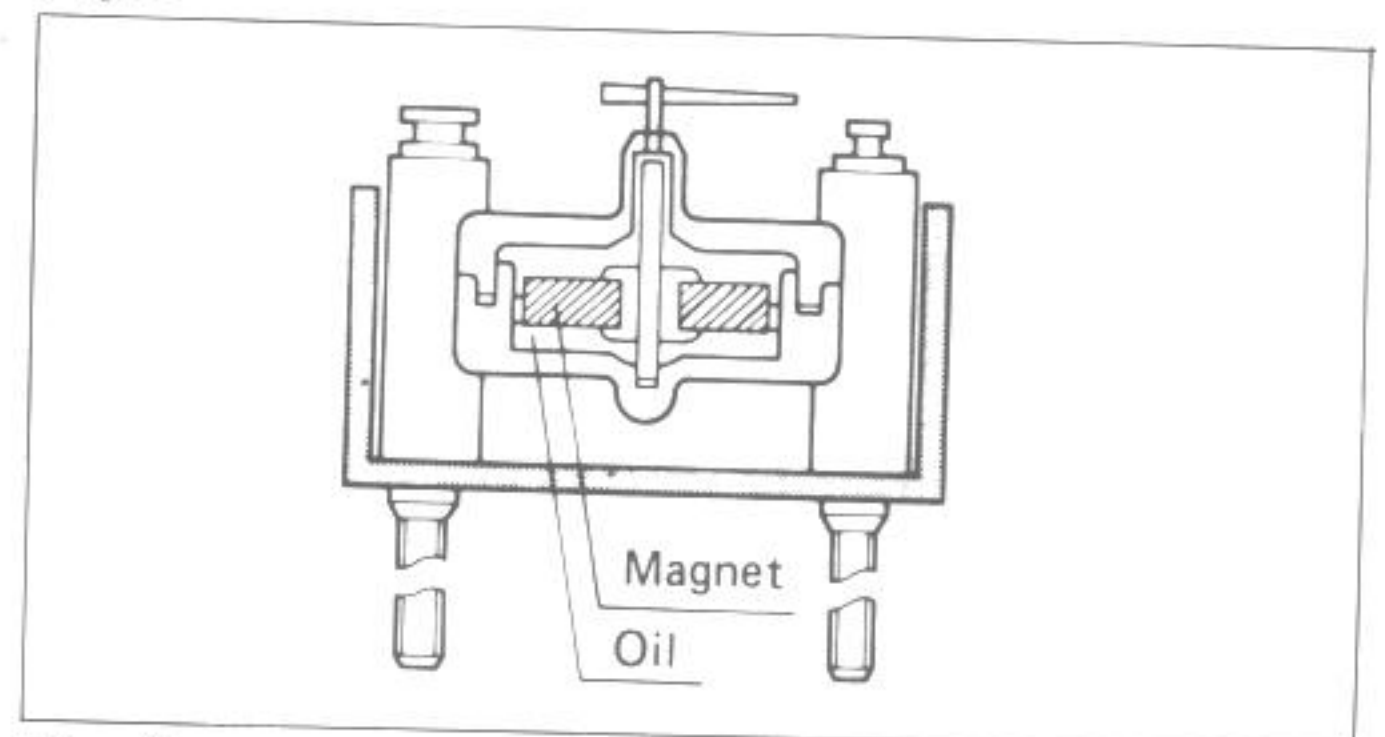

Fig. 4

NOTE:

Prior to testing the Fuel Level system, verify that the battery is in a fully charged condition.

FUEL METER INSPECTION

To test the Fuel Meter two different checks may be used. The first, and simplest test will tell if the meter is operating but will not indicate the meters accuracy throughout the range.

To perform this test, disconnect the B/W and Y/B lead wire of the fuel meter and the ground lead wire. Connect a jumper wire between B/W and Y/B wires coming from the main wiring harness. With the ignition switch turned on, the fuel meter should indicate "F".

The second test will check the accuracy of the meter in the full and empty positions.

Connect a 50-ohm resistor between the Y/B lead wire of the fuel gauge and the ground lead wire. The fuel gauge is normal if its pointer indicates the E (empty) position when the specified voltage is applied to the circuit and if its pointer indicates the F (full) position when the resistor is changed to 7 ohms. If either one or both indications are abnormal, replace the fuel meter with a new one.

FUEL GAUGE SENDING UNIT

- Remove the lead wires coming out of the fuel gauge and check resistance of each of them.
- If the resistance measured is incorrect, replace the fuel gauge assembly with a new one.
- The relation between the position of the fuel gauge float, resistance, and fuel quantity is shown in the following table.

Float position	Resistance	Fuel quantity
F	5 – 10 Ω	Approx. 19.2L
1/2	30 – 35 Ω	Approx. 10.0L
E	40 – 60 Ω	Approx. 4.7L

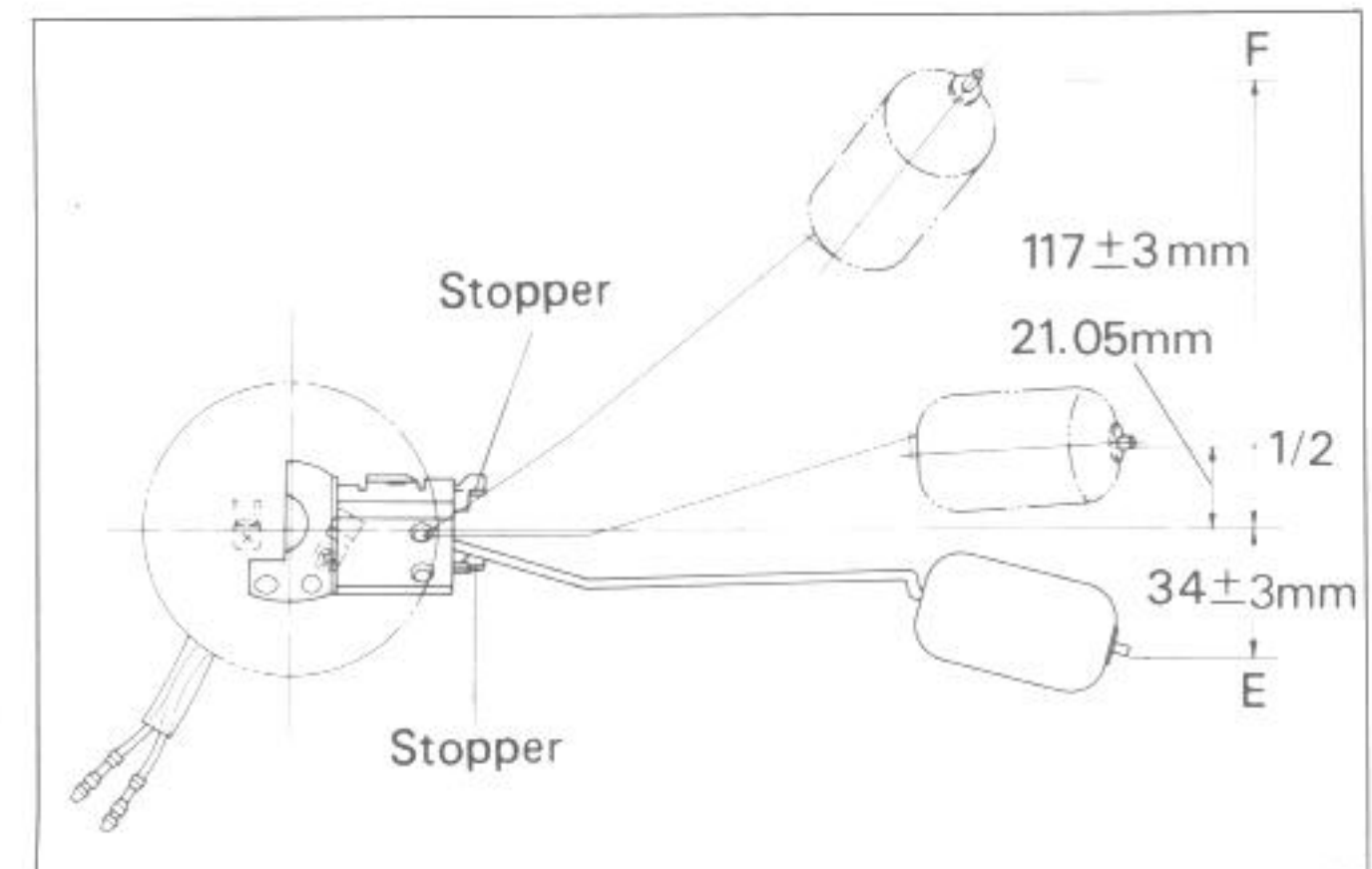
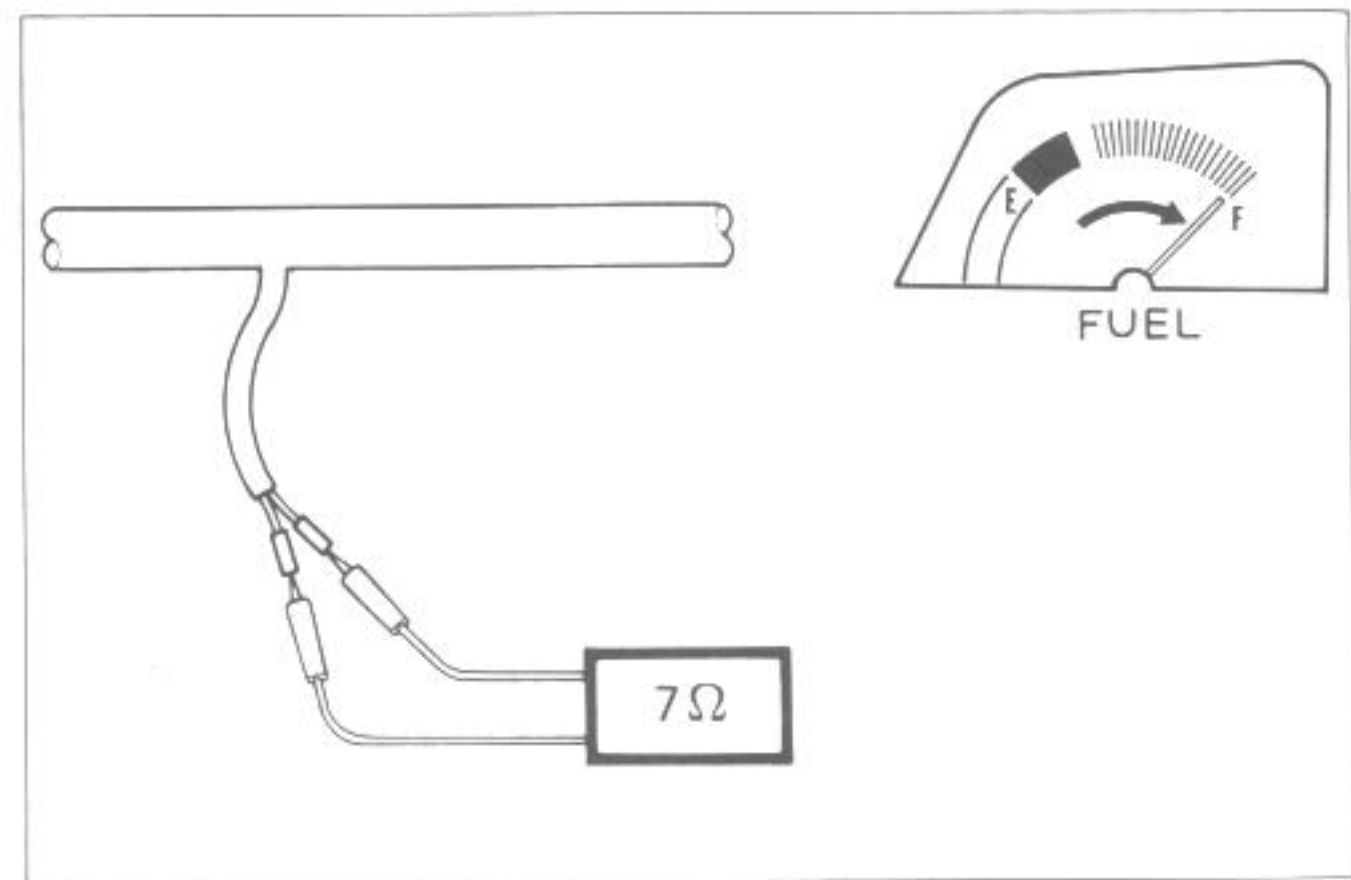
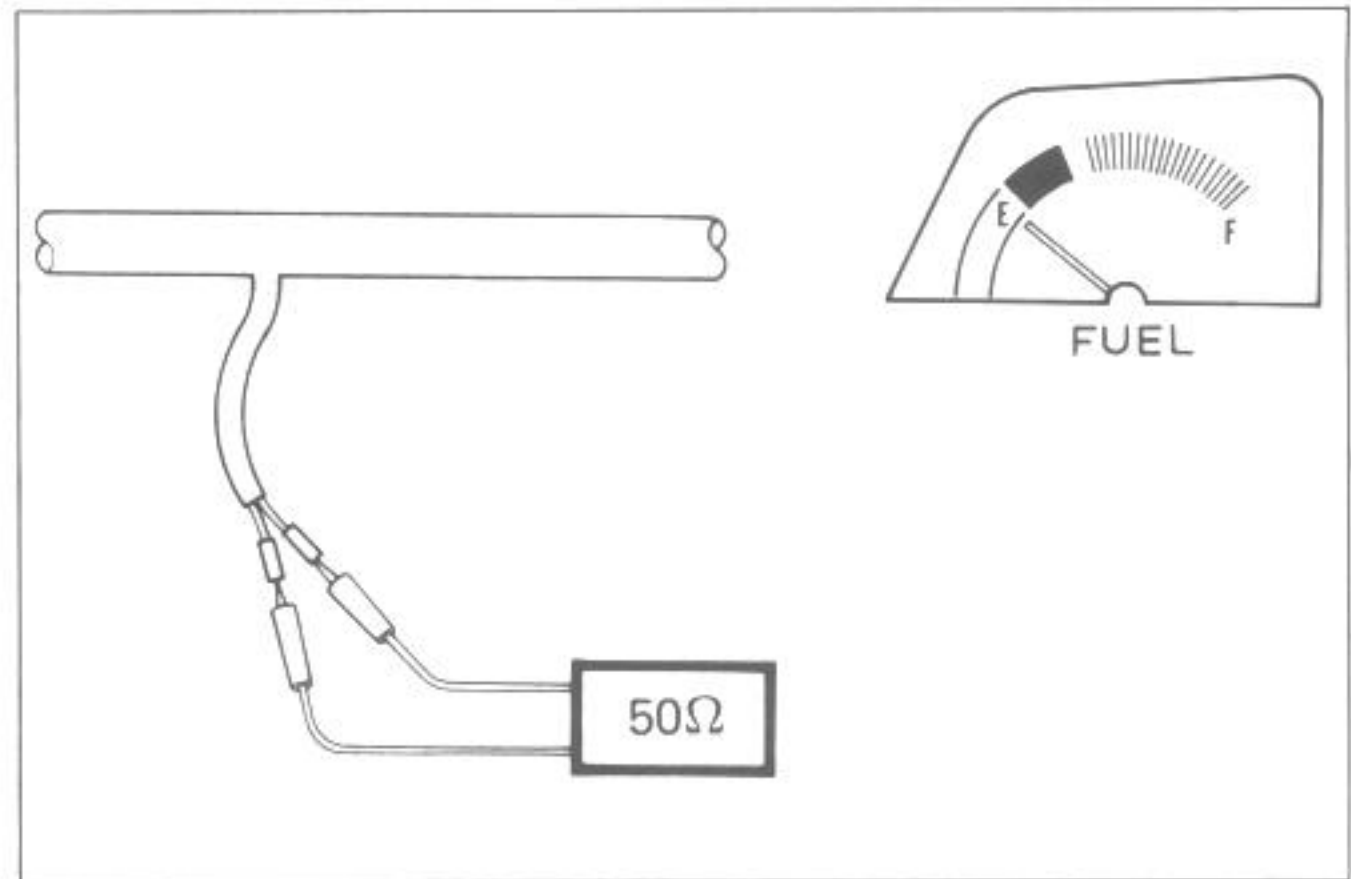

ENGINE OIL TEMPERATURE METER

INSPECTION

As the coil spring is installed on the needle shaft of the oil temperature meter, the needle is forced back to the original position when ignition switch is turned OFF.

To test the engine oil temperature meter two different checks may be used. The first, and simple test will tell if the meter is operating but will not indicate the meters accuracy throughout the range.

To perform this test, disconnect the pink lead wire of the engine oil temperature meter from the oil temperature gauge. Connect a jumper wire between pink wires coming from the main wiring harness and engine ground. With the ignition switch turned on, the oil temperature meter should indicate "H".

The second test will check the accuracy of the meter in the "H" and "C" positions.

Connect a 47-ohm resistor between the pink lead wire of the oil temperature gauge and the engine ground. The oil temperature gauge is normal if its pointer indicates the 60°C position when the specified voltage is applied to the circuit and if its pointer indicates the 100°C position when the resistor is changed to 16-ohm. If either one or both indications are abnormal, replace the oil temperature meter with a new one.

ENGINE OIL TEMPERATURE METER SPECIFICATION

POSITION	RESISTANCE
①	$47 \pm 5 \Omega$
②	$16 \pm 5 \Omega$

TEMPERATURE SENSOR

Test the temperature gauge sensor at the bench to see if its ohmic value changes, as specified with, temperature. The test is to be run as follows: Connect the temperature gauge to the ohmmeter and place it in the oil contained in a pan, which is placed on a stove; heat the oil to raise its temperature slowly, reading the thermometer placed in the jar and also the ohmmeter. A temperature gauge whose ohmic value does not change in the proportion indicated in the next page must be replaced.

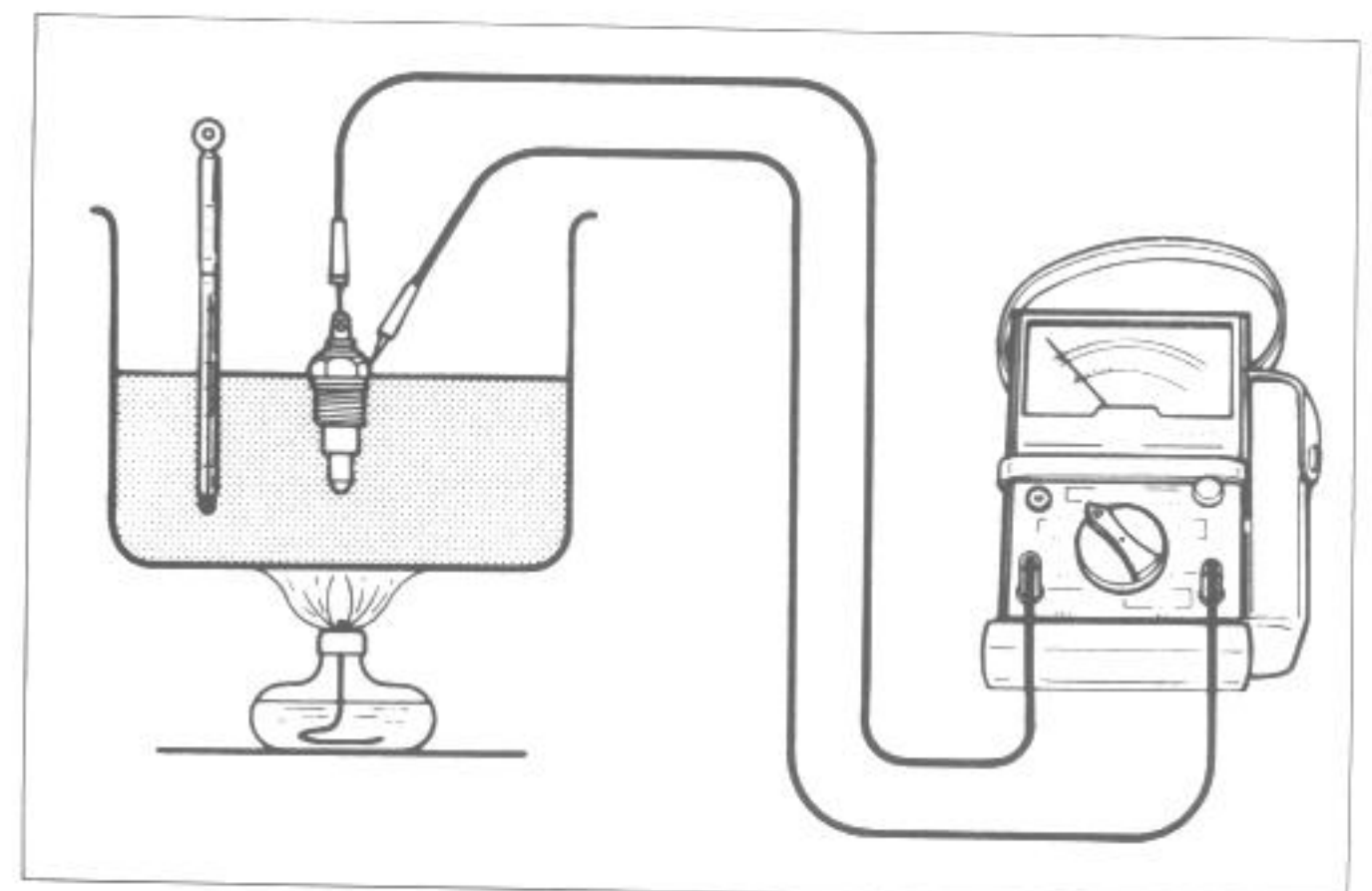
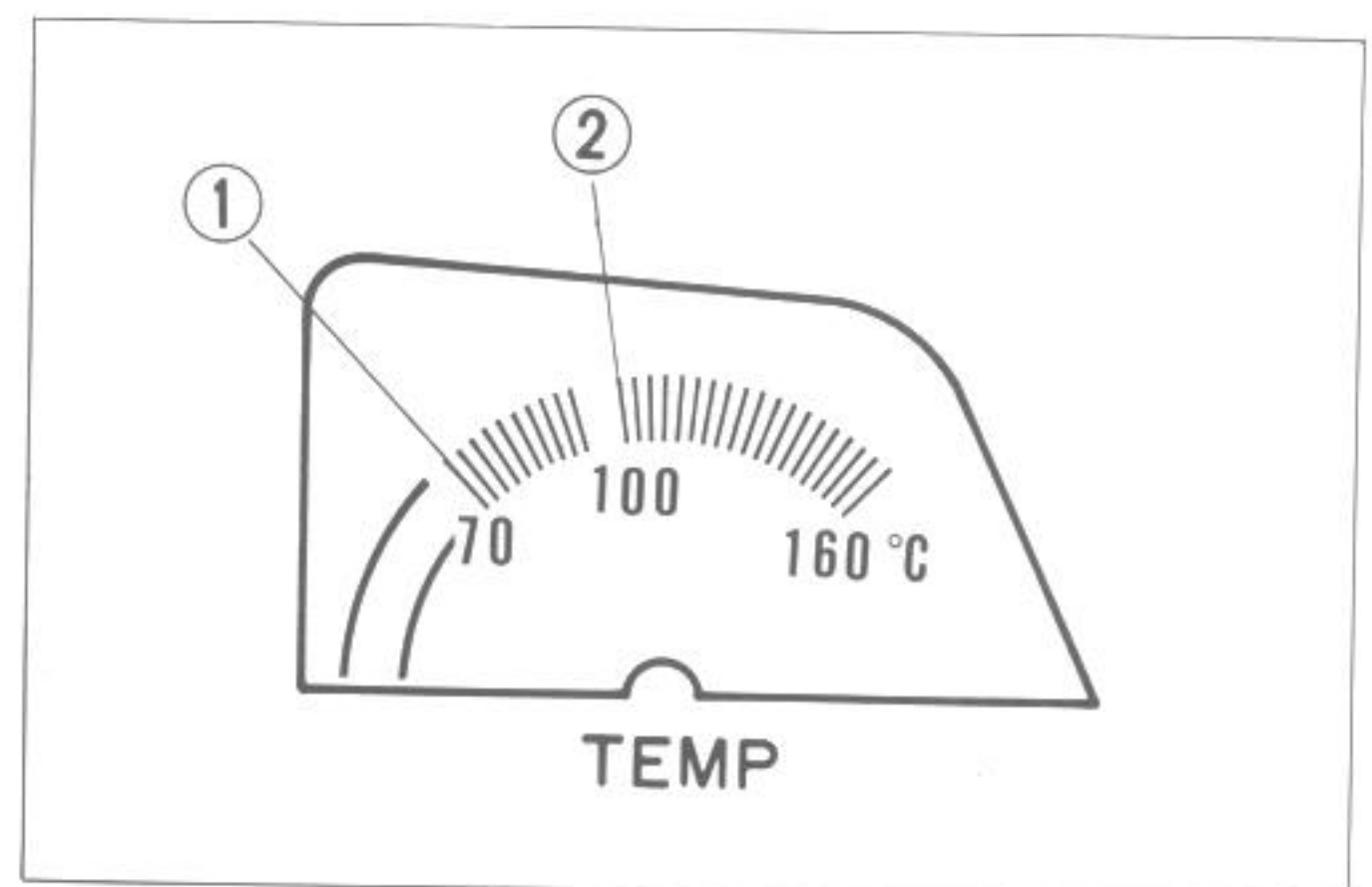
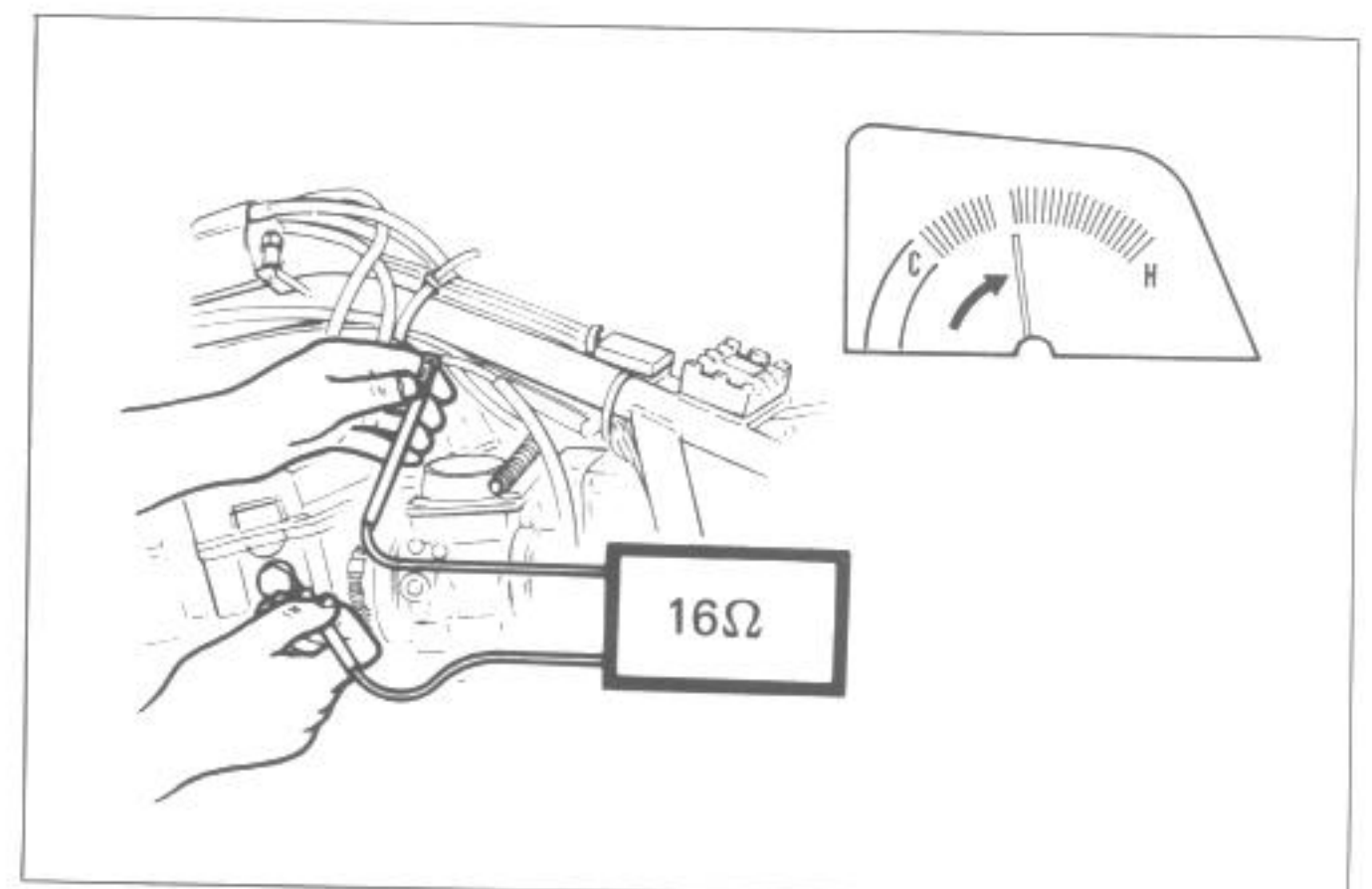
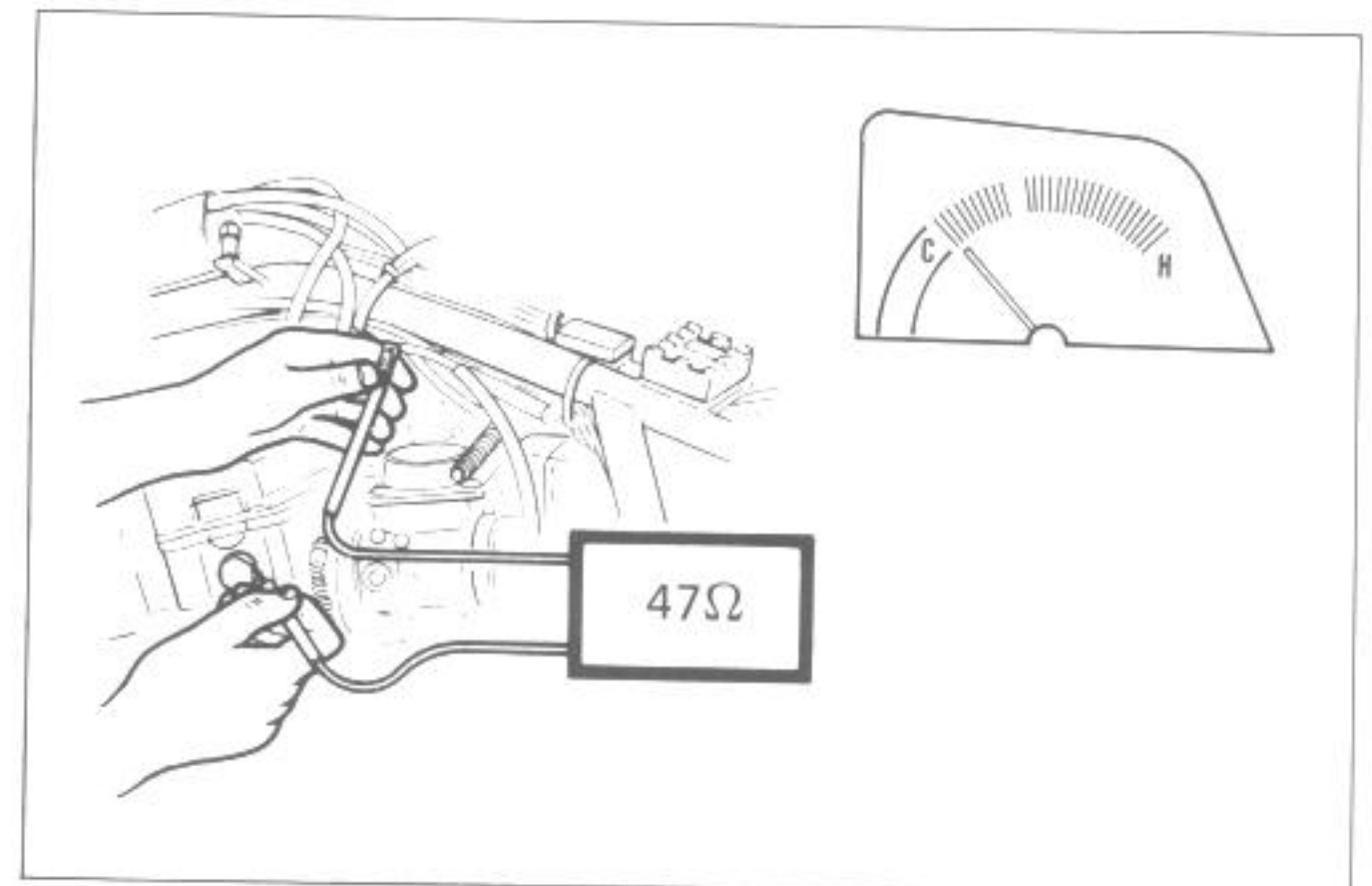

Temperature gauge sensor specification

Oil temp. (°C)	Standard resistance (Ω)
50	Approx. 155
100	38
130	19
150	13

If the resistance noted to show infinity or too much difference in the resistance value, the temperature gauge sensor must be replaced.

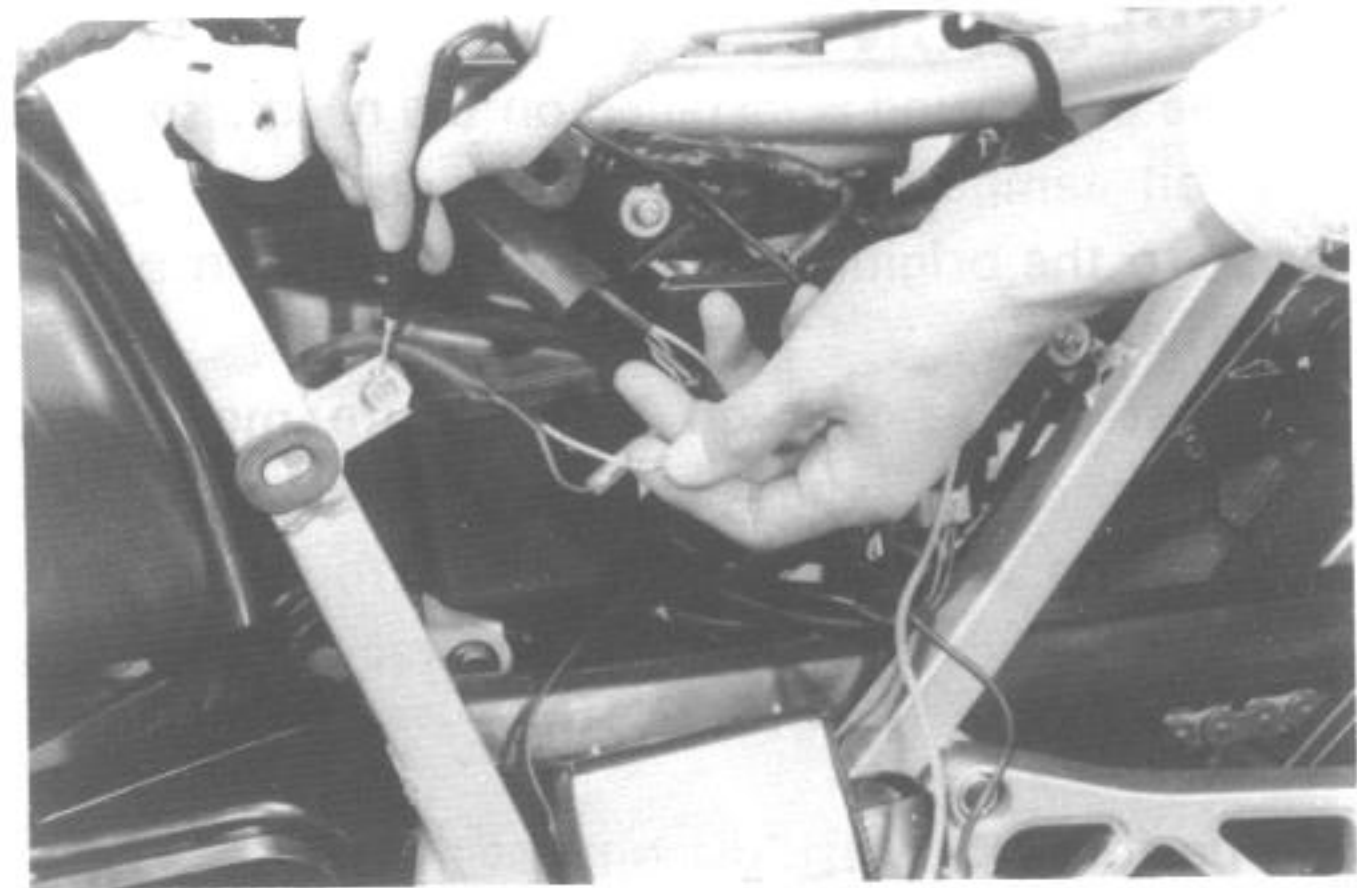

MONITOR SYSTEM

The monitor unit is installed under the right frame cover. It monitors open circuit in the headlamp and tail/brake lamp and also has a function for checking for disconnection of the monitor bulbs.

The indicator lamp lights up when a disconnection occurs.

The battery solution level is monitored in the same ways and indicator lamp lights when the solution level drops below the MIN. level.

The oil pressure switch controls all the indicator bulb circuits, and all the indicator bulbs in the following circuit diagram light up when the engine oil pressure is low and the pressure switch is closed. After starting engine all the indicator lamps except side stand indicator lamp turn off when the oil pressure switch is opened.

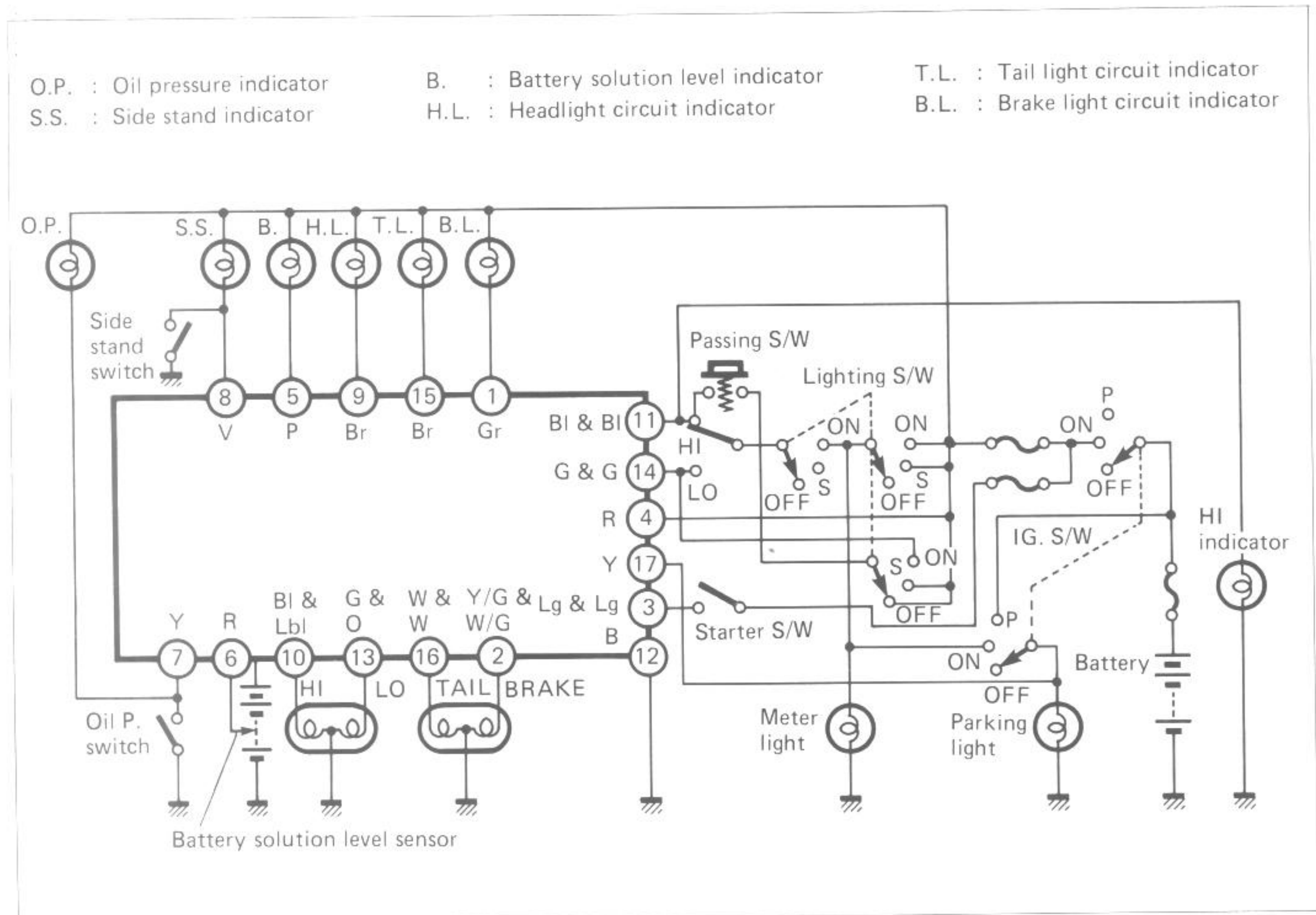

INSPECTION

Before checking this monitor unit, check the following items.

NOTE:

None of the indicator works properly in the meter cluster when oil pressure switch is out of order.

- Indicator bulbs (Headlight, Tail lamp, Brake lamp, Battery, Side stand and Oil pressure)
- Switches (Ignition, Lighting and Dimmer)
- Bulbs (Headlight and Tail/Brake light)
- Battery electrolyte level sensor and Battery charged condition
- Fuses and Wiring harness to and from the meter cluster

HEAD, TAIL AND BRAKE LIGHT CIRCUITS

- Turn the ignition switch in the ON position and start the engine.
- Disconnect the socket from the headlight bulb, and also disconnect the tail/brake light lead wire. Confirm that the indicator bulbs remains lit when disconnecting socket or lead wires and indicator bulbs go out when reconnecting lead wires.

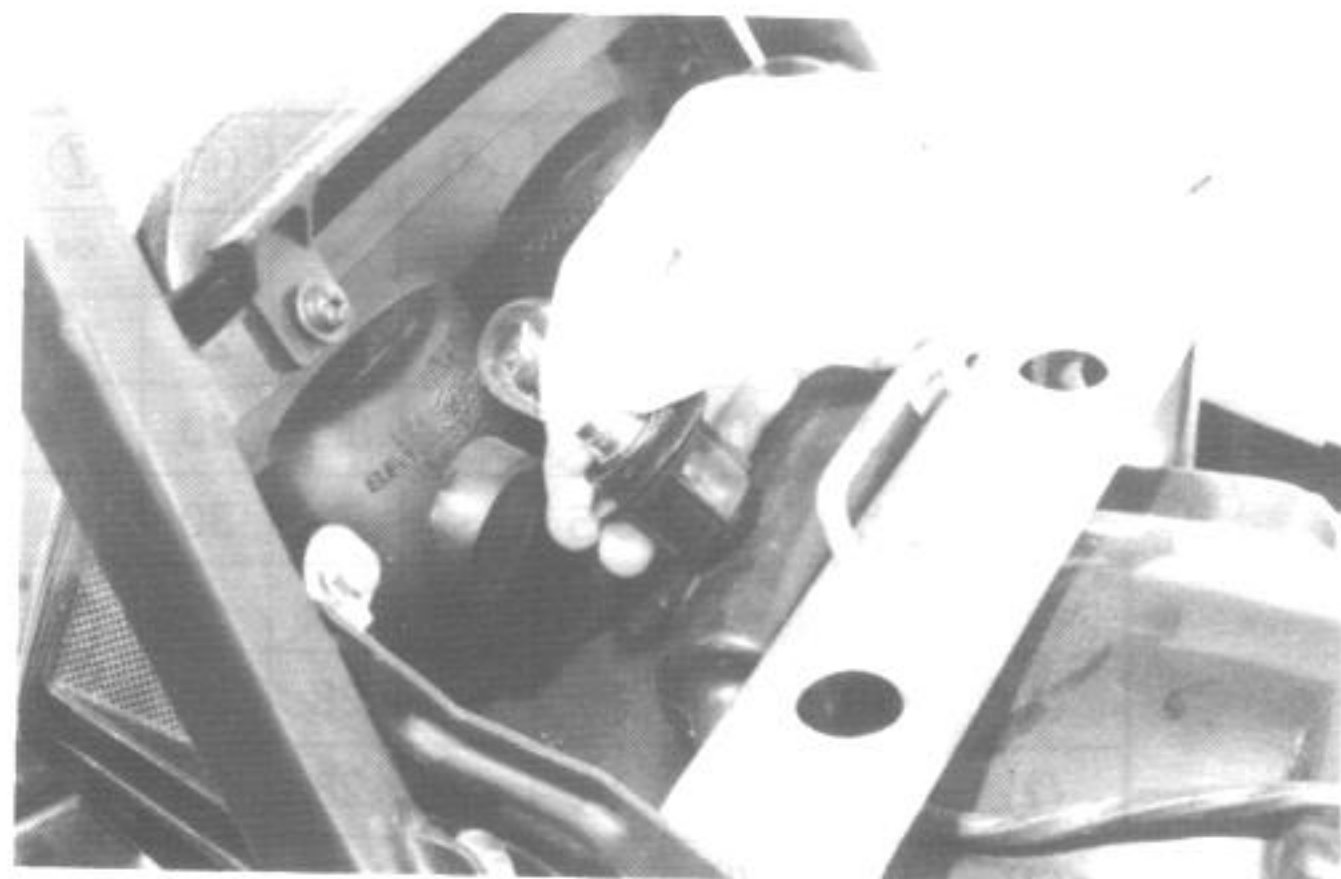

BATTERY ELECTROLYTE LEVEL SENSOR

Check the voltage between the level sensor lead and minus \ominus terminal of the battery. If the specified voltage is not observed, replace the level sensor.

NOTE:

The battery should be fully charged condition, and the solution be kept at an upper level.

STD voltage

Over 3.0 V

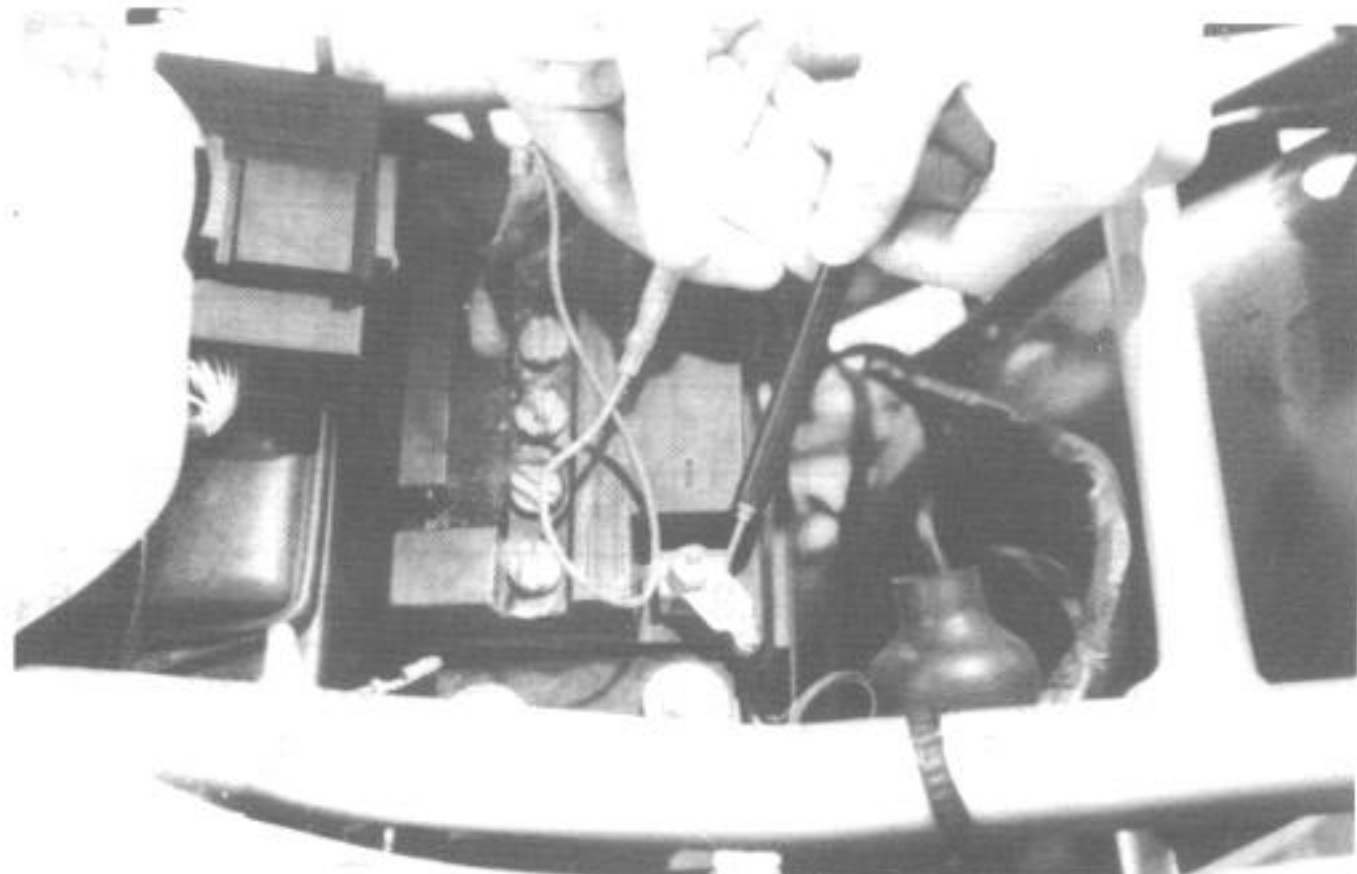

MONITOR INSPECTION

- Use the Suzuki pocket tester, bring the ⊕ probe and the ⊖ probe into contact with each lead wire of the monitor, check for continuity, and measure the resistance value.
- When the continuity and the resistance values are as shown in the following table, it can be judged that the monitor unit is normal.

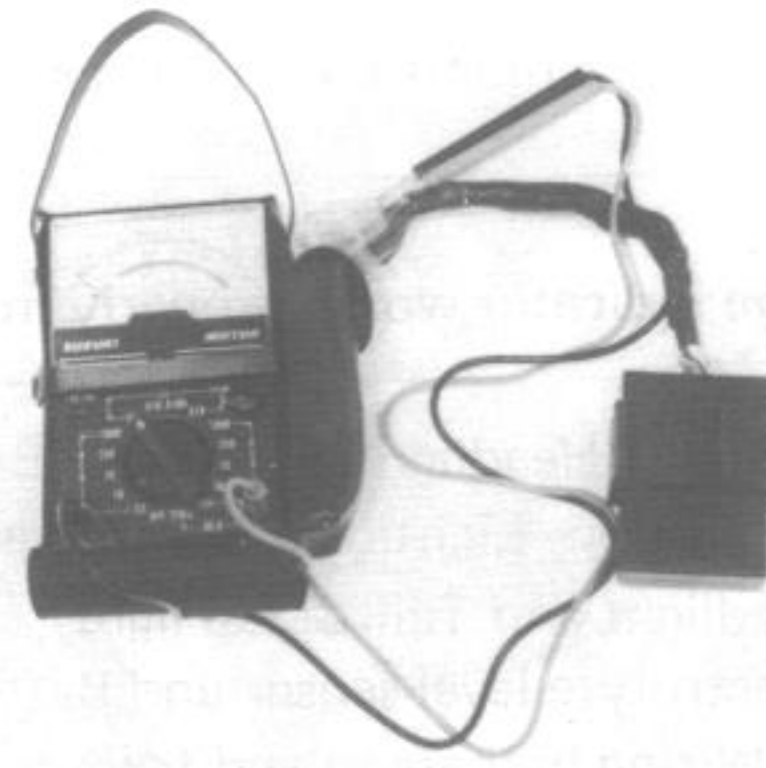

CAUTION:
As transistors, capacitors, diodes, ICs, etc. are used inside this monitor unit, the resistance values will differ when an ohmmeter other than Suzuki pocket tester is used.

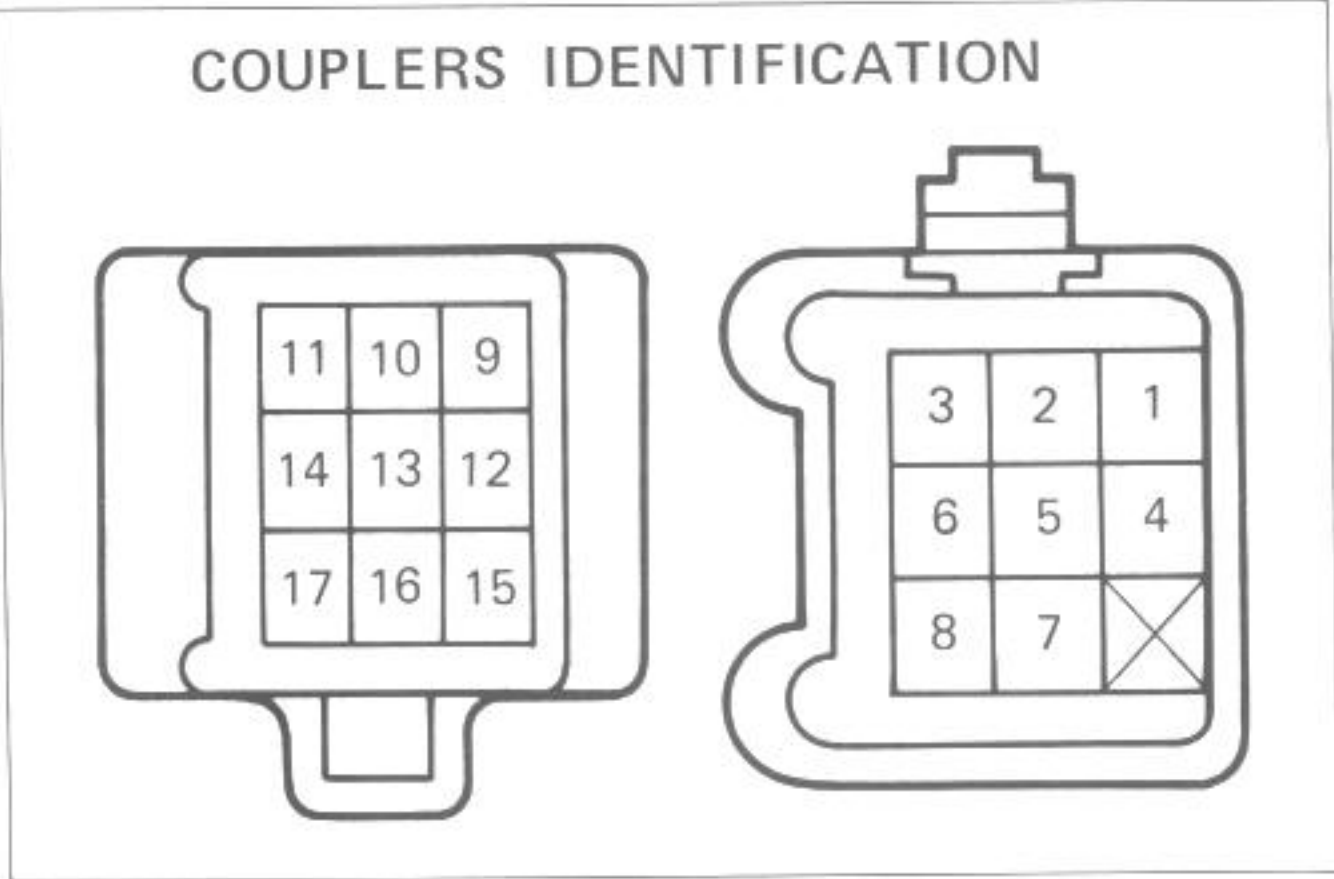

Unit: X kΩ ± 40% kΩ

⊖ ⊕	①	②	③	④	⑤	⑥	⑦	⑧	⑨	⑩	⑪	⑫	⑬	⑭	⑮	⑯	⑰
①	∞	∞	∞	∞	∞	∞	∞	∞	∞	∞	∞	∞	∞	∞	∞	∞	∞
②	9	0	∞	8.5	20	7.5	∞	8.5	7.5	7.5	3.5	0.8	0.8	8.5	0.8	∞	
③	9	0	∞	8.5	20	7.5	∞	8.5	7.5	7.5	3.5	0.8	0.8	8.5	0.8	∞	
④	22	3.5	3.5	∞	20	30	16	∞	20	18	18	7.5	3.5	3.5	20	3.5	∞
⑤	∞	∞	∞	∞	∞	∞	∞	∞	∞	∞	∞	∞	∞	∞	∞	∞	∞
⑥	28	14	14	∞	28	∞	28	∞	25	25	25	14	14	14	26	14	∞
⑦	28	13	14	∞	28	30	∞	25	25	25	16	13	13	26	13	∞	
⑧	50	20	20	∞	48	45	3	∞	50	40	40	25	20	20	50	20	∞
⑨	∞	∞	∞	∞	∞	∞	∞	∞	∞	∞	∞	∞	∞	∞	∞	∞	∞
⑩	12	10	10	∞	12	25	17	∞	12	0	5	10	10	13	10	∞	
⑪	12	10	10	∞	12	25	17	∞	12	0	5	10	10	13	10	∞	
⑫	3.5	2.5	2.8	∞	3.8	16	9	∞	3.6	2.8	2.8	∞	2.6	2.5	3.5	2.6	∞
⑬	8.5	0.8	0.8	∞	8.5	20	7.5	∞	8.5	7.5	7.5	3.2	∞	0	8.5	0.8	∞
⑭	8.5	0.8	0.8	∞	8.5	20	7.5	∞	8.5	7.5	7.5	3.2	0	∞	8.5	0.8	∞
⑮	500	∞	∞	∞	∞	∞	∞	∞	∞	∞	∞	∞	∞	∞	∞	∞	∞
⑯	8.5	0.8	0.8	∞	8.5	20	7.5	∞	8.5	7.5	7.5	3.2	0.8	0.8	8.5	∞	∞
⑰	20	3.5	3.8	∞	20	30	16	∞	20	17	17	7.5	3.6	3.6	20	2.8	∞

LAMPS

HEADLIGHT

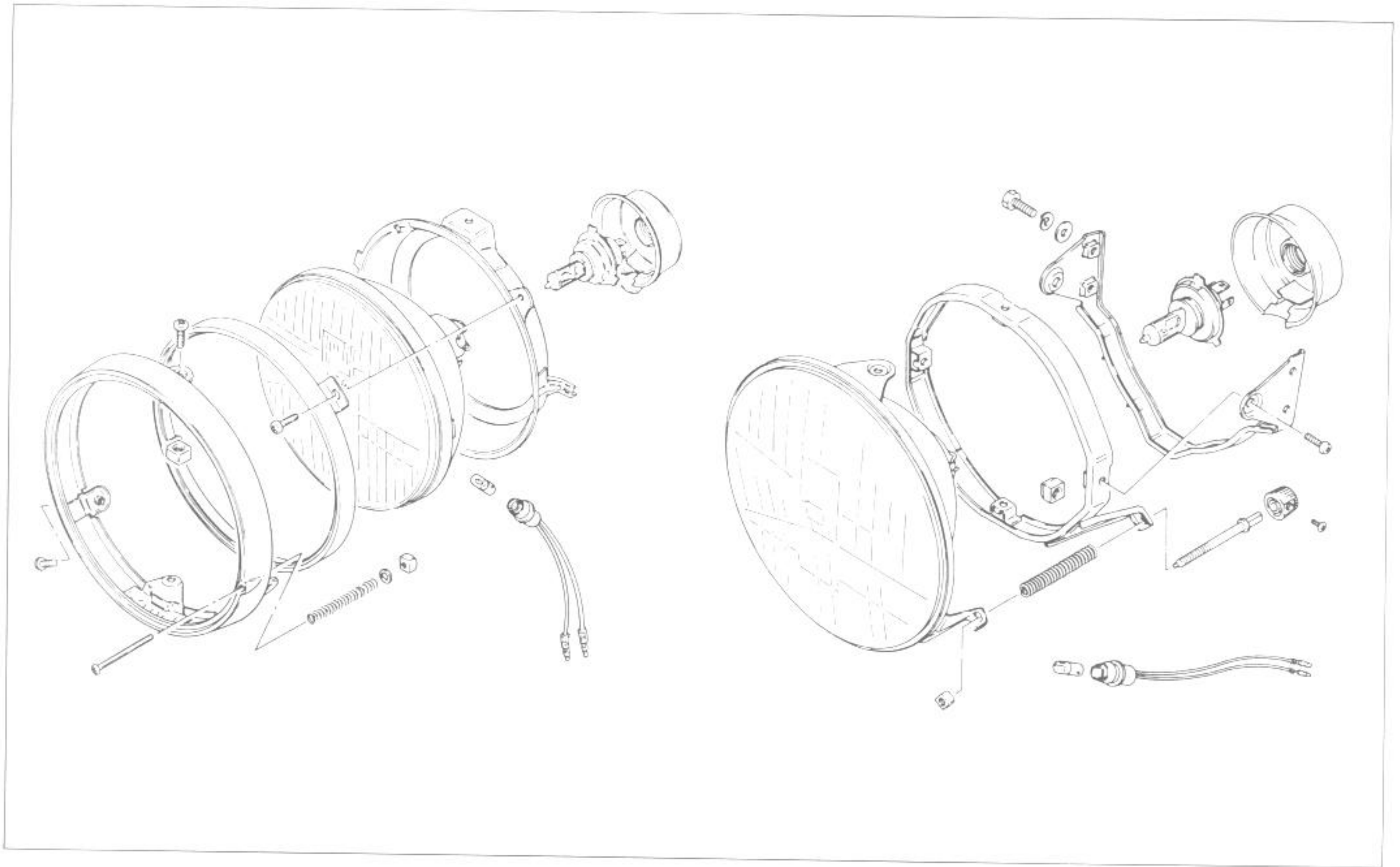

TAIL / BRAKE LIGHT

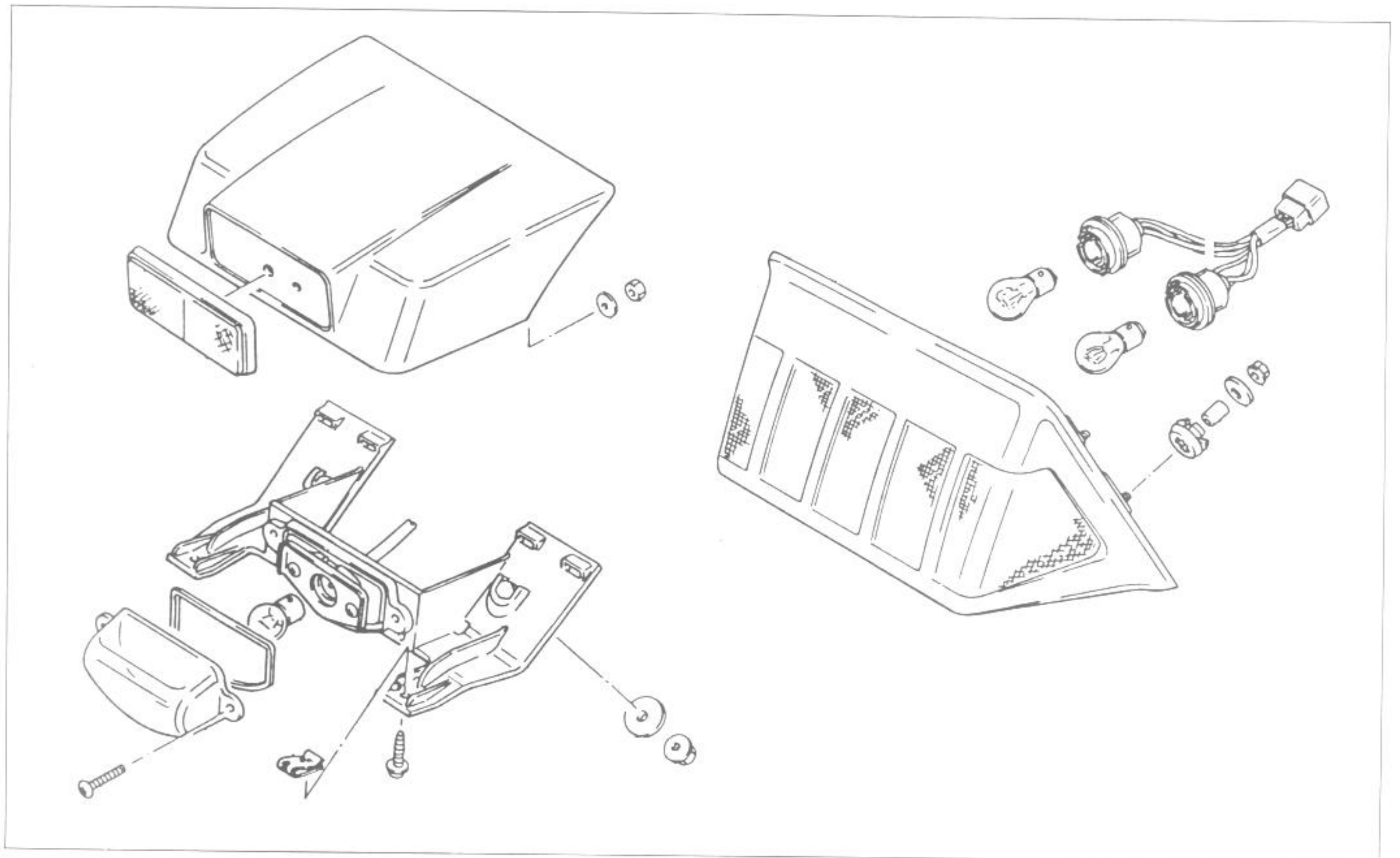

TURN SIGNAL LIGHT

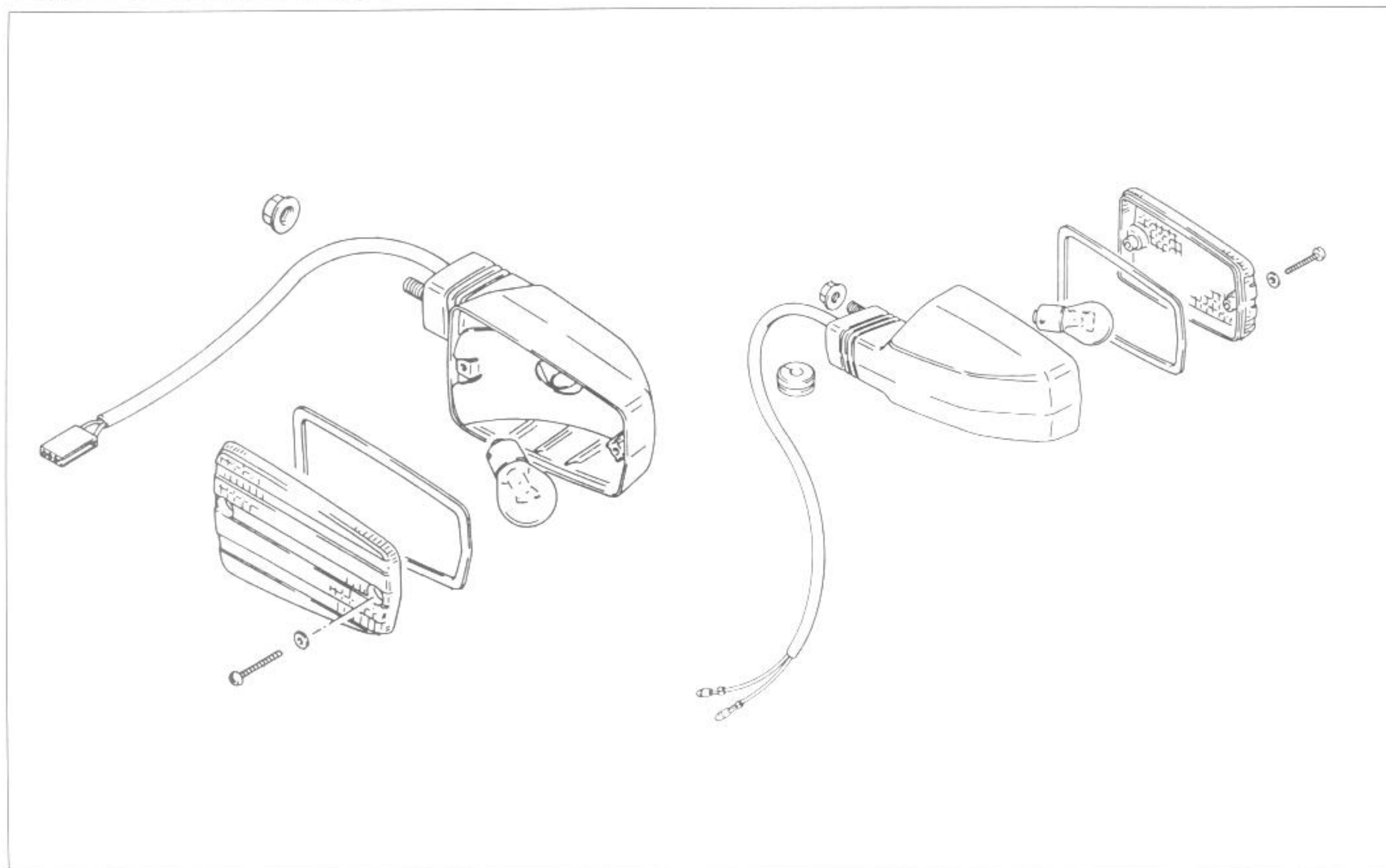

SWITCHES

Inspect each switch for continuity with the pocket tester referring to the chart.

If any abnormality is found, replace the respective switch assemblies with new ones.

09900-25002	Pocket tester
-------------	---------------



IGNITION SWITCH

Wire color	R	O	Gr	Br
OFF				
ON	○—○		○—○	
P	○—○			○—○

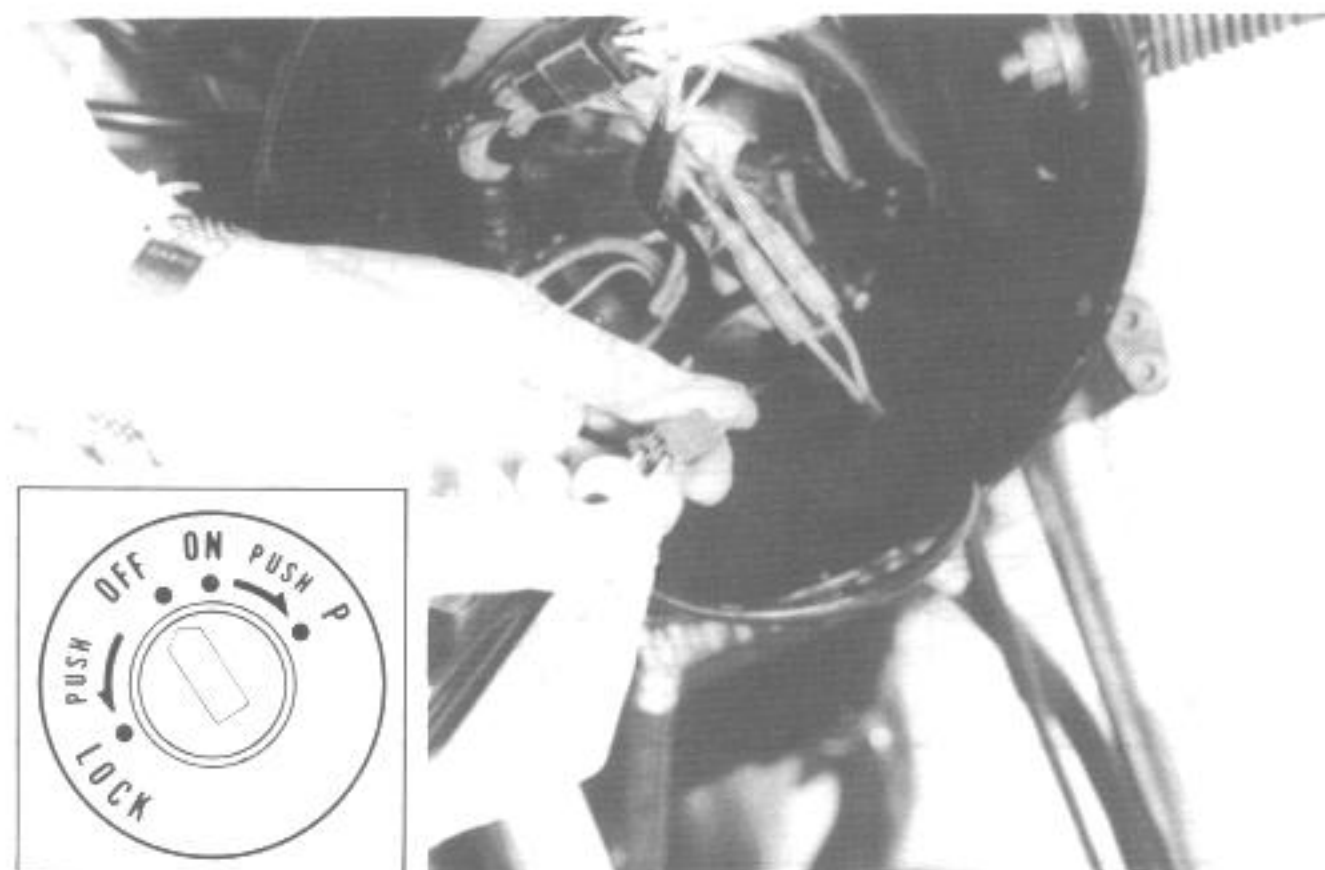

RIGHT HANDLEBAR SWITCH

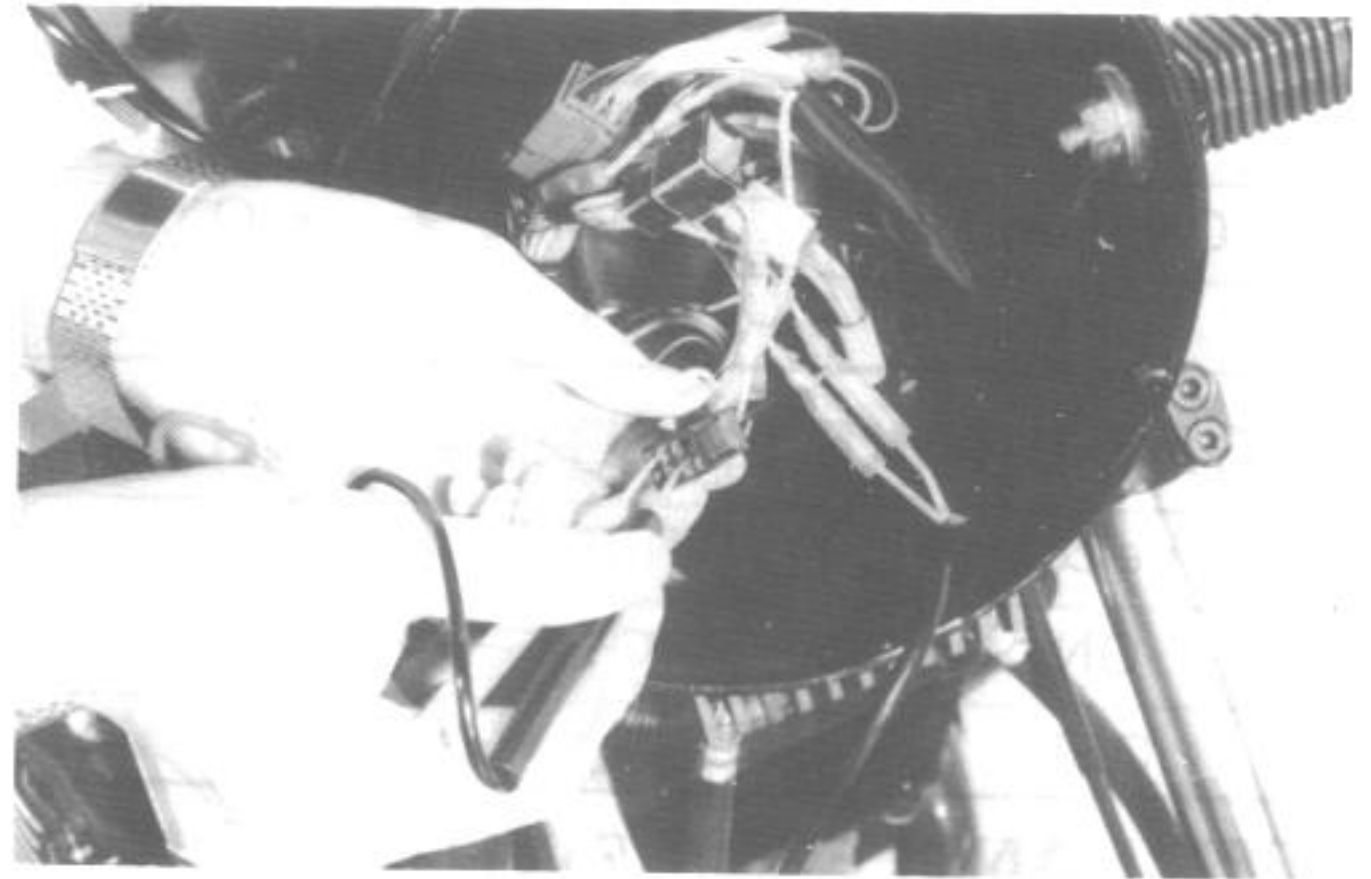

ENGINE STOP SWITCH

Wire color	O/W	O/W
RUN		
OFF		

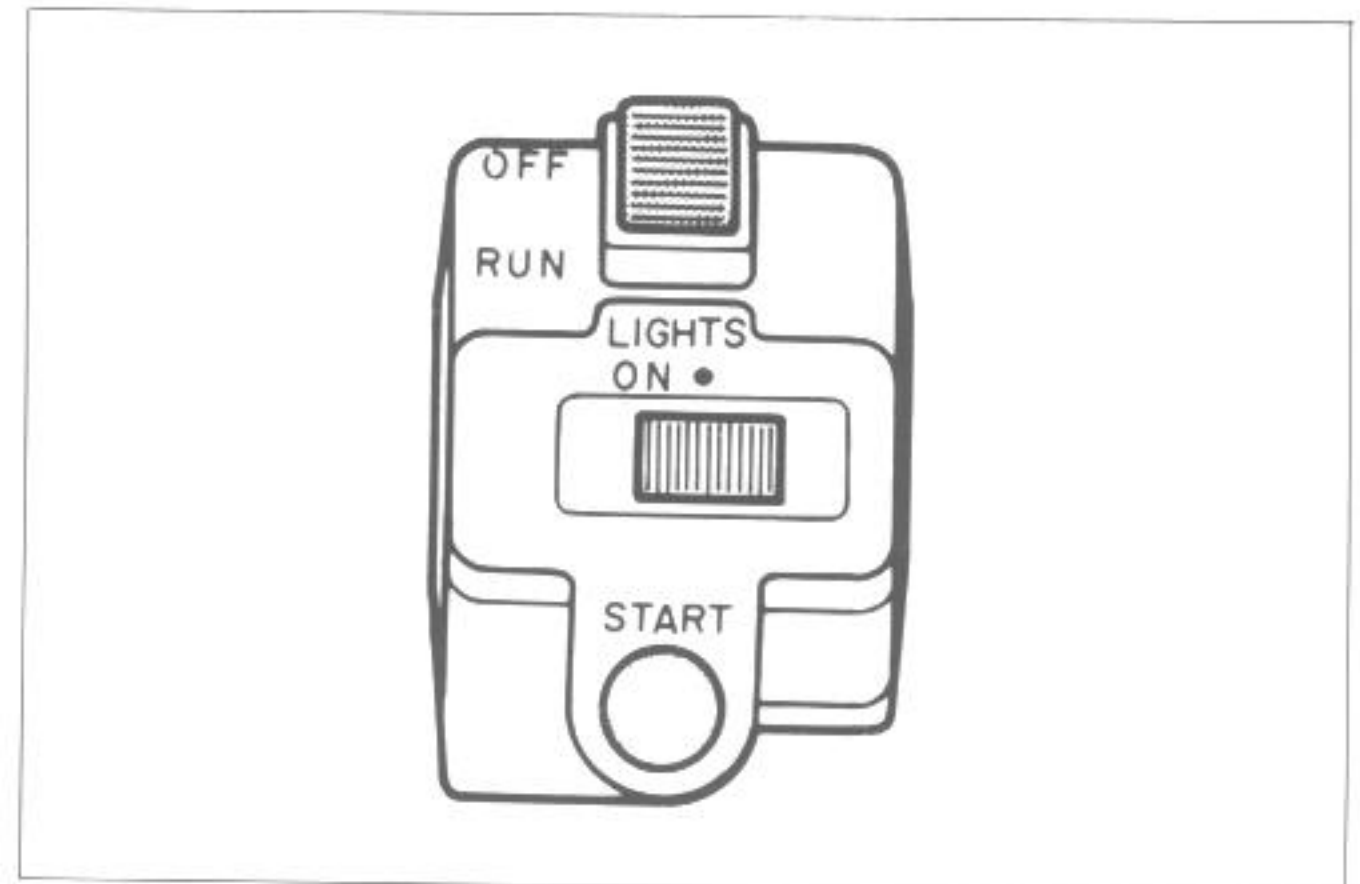

LIGHTING SWITCH (Except for Canada)

General and the Others

Wire color	O/G	Gr	O/R	Y/W
ON				
OFF				

For E-02, 04, 15, 16, 17, 18, 21, 22, 25, 26 and 34

Wire color	O/G	Gr	O/R	Y/W
ON				
S				
OFF				

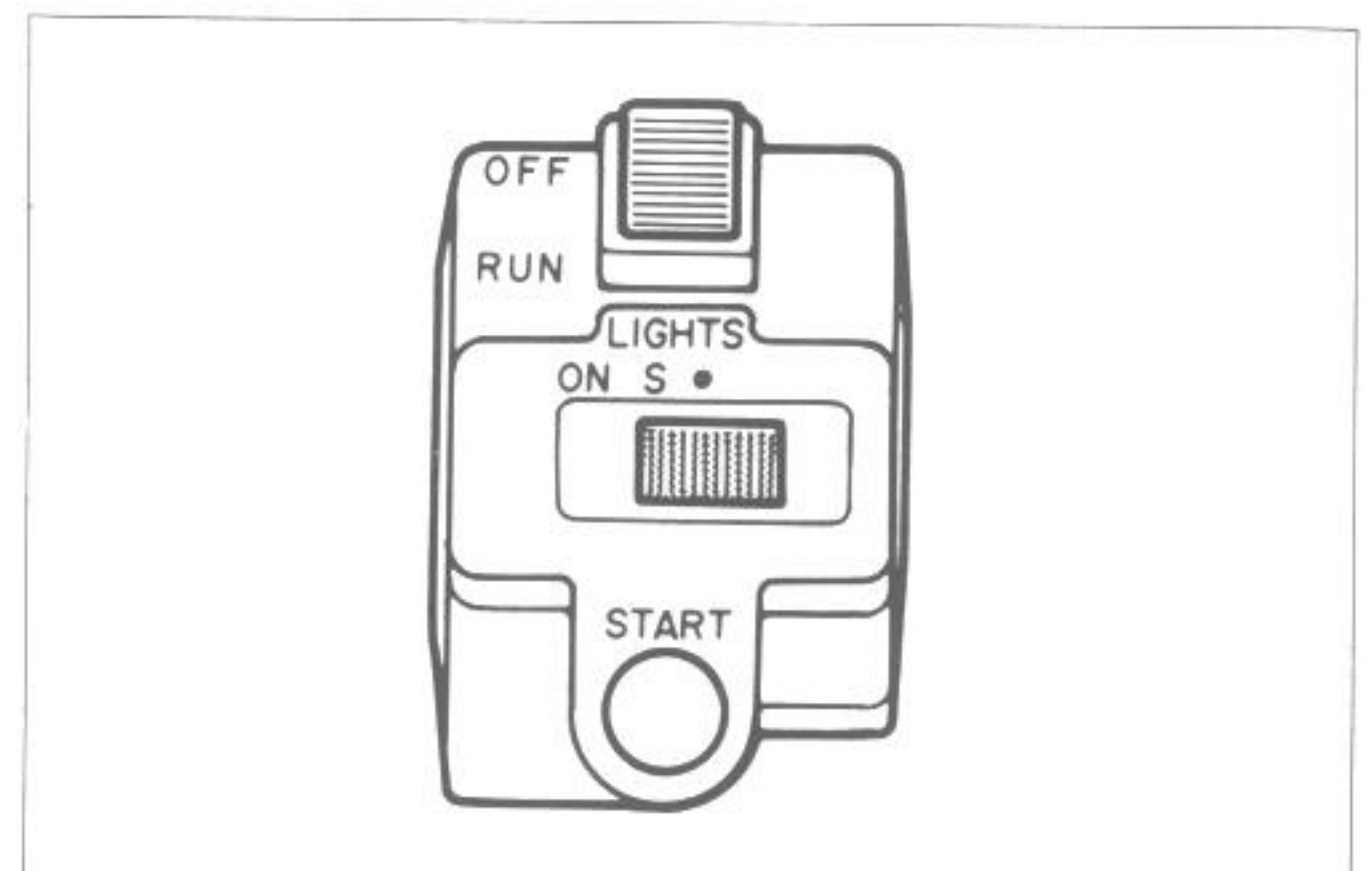
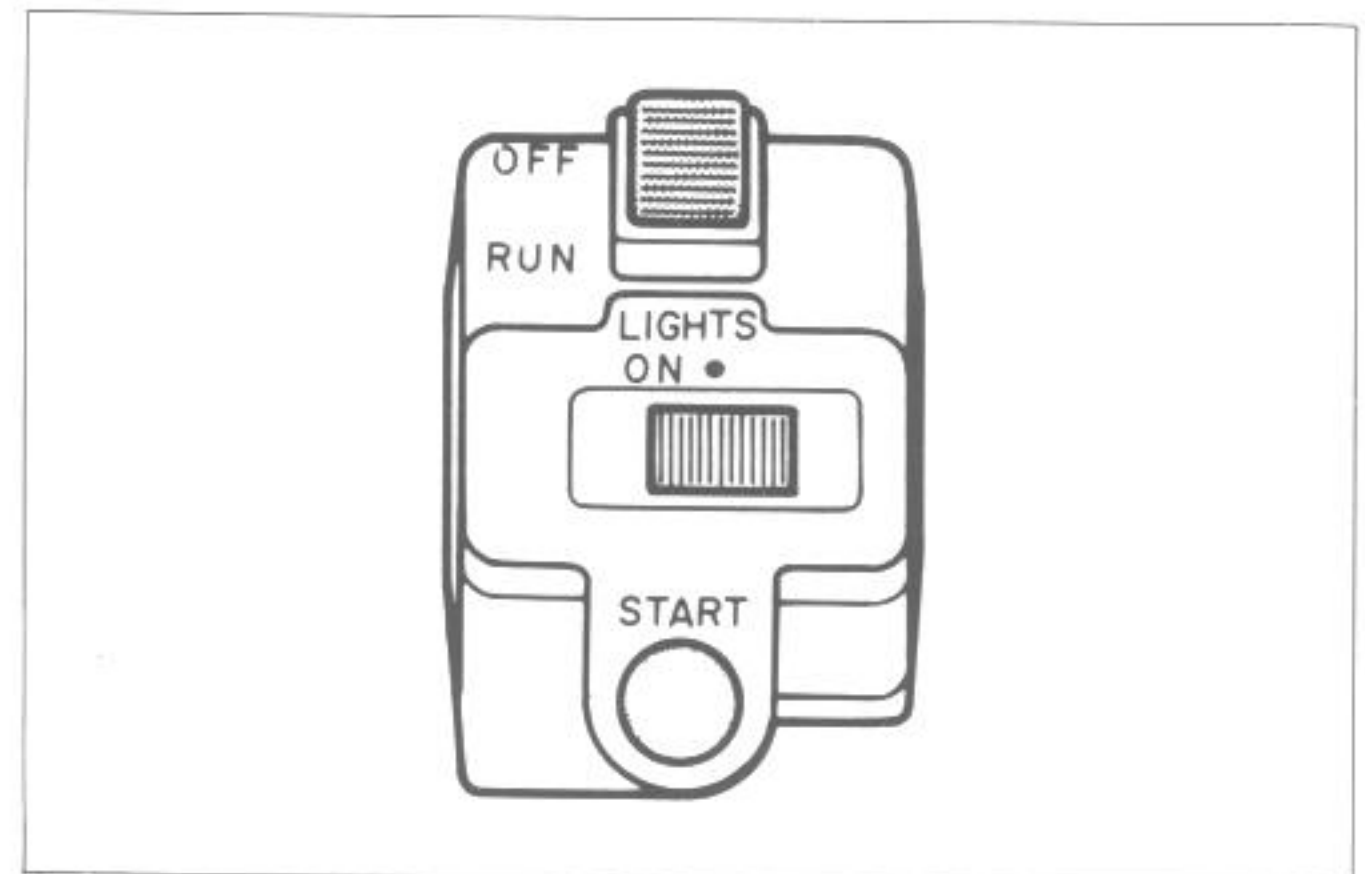

STARTER SWITCH

Wire color	O/W	Y/G
ON (Push)		
OFF		

FRONT BRAKE LIGHT SWITCH

Wire color	O/G	R/BI
ON		
OFF		

LEFT HANDLEBAR SWITCH DIMMER SWITCH

General and the Others

Wire color	W	Y	Y/W	O/R
HI				
LO				
PASS				

For Italy

Wire color	W	Y	Y/W	O/R
HI				
LO				
PASS				

For Canada

Wire color	W	Y	Y/W
HI			
LO			

TURN SIGNAL SWITCH

General and the Others

Wire color	B	Lbl	Lg	O/R	Lg/B	Br/Y	B/W
R							
(R)							
C							
(L)							
L							

Only for E22

Wire color	Lg	Lbl	B
R			
•			
L			

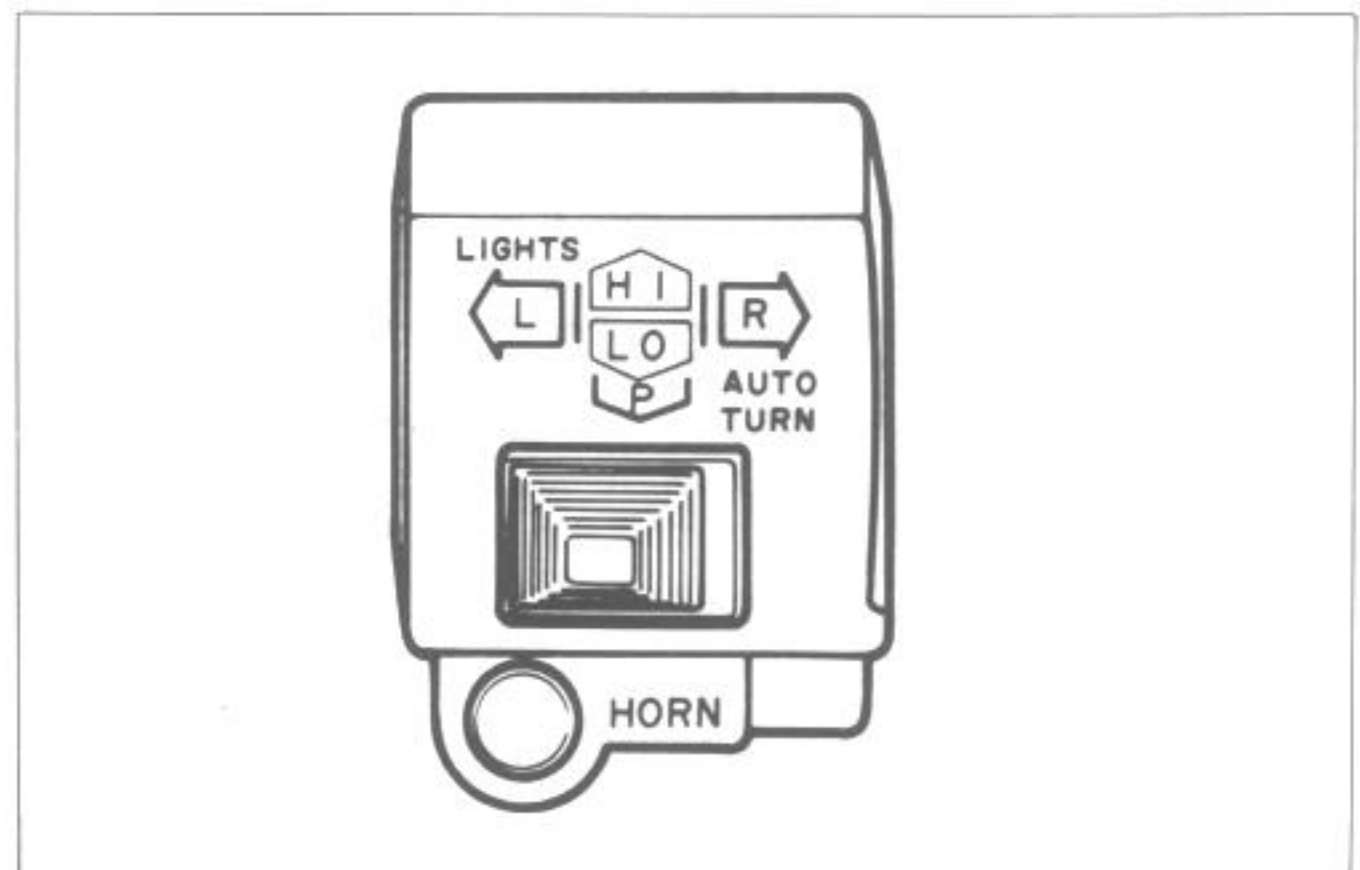
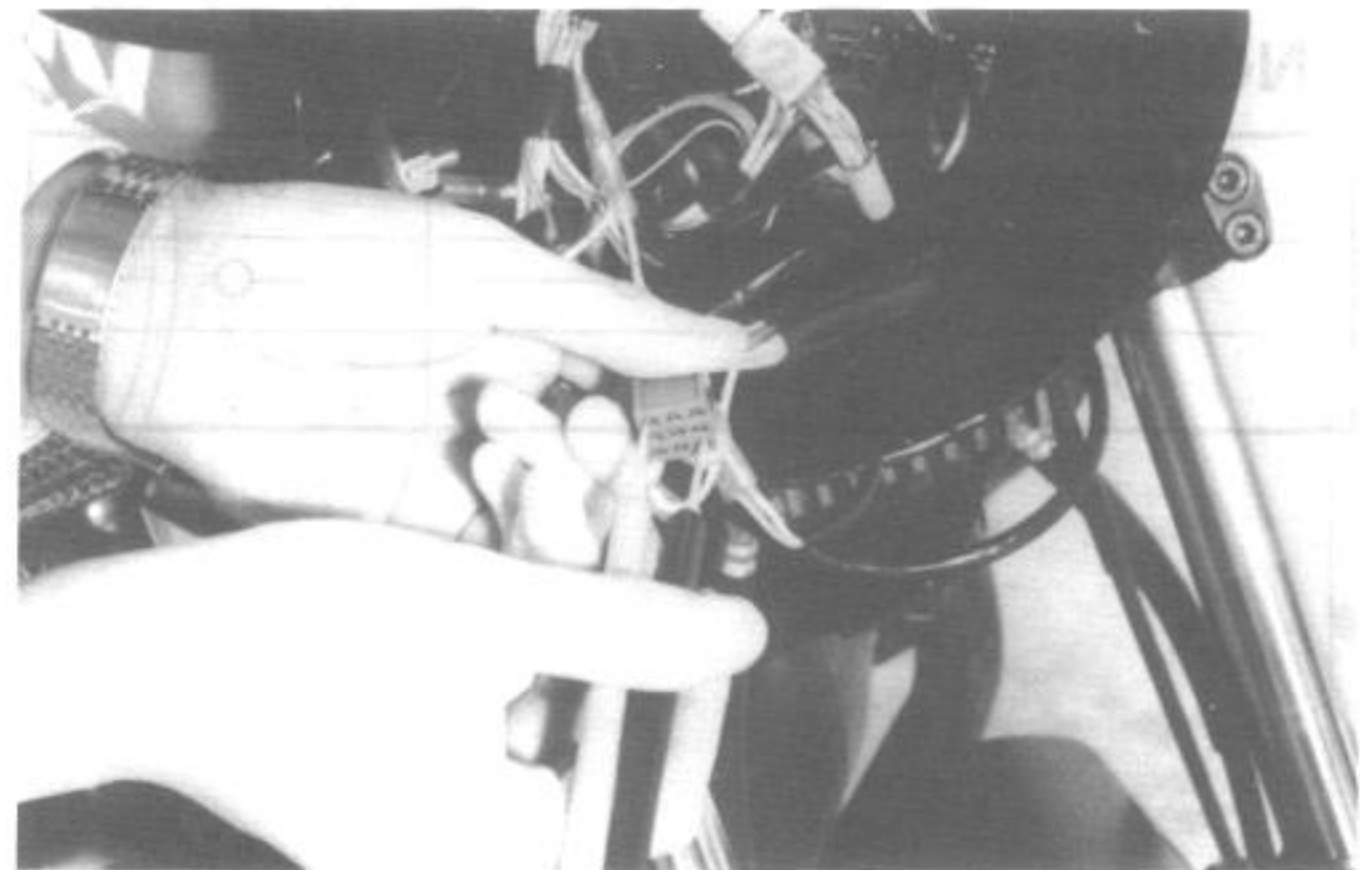
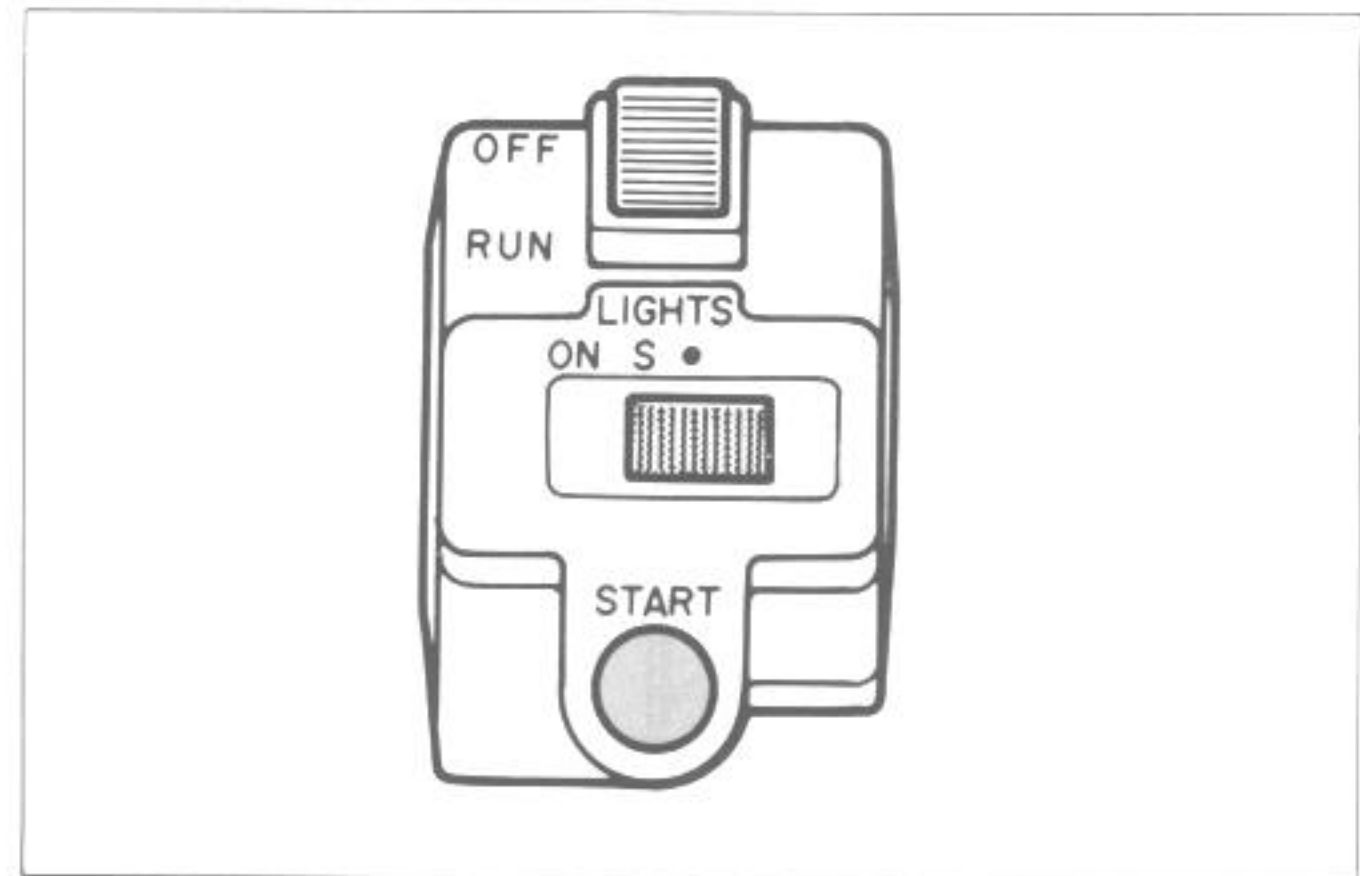

HORN SWITCH

Wire color	G	B/W
OFF		
ON (Push)		

STATER DISCONNECT SWITCH

(Only for Canada)

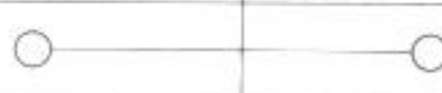
Wire color	Y/G	Y/G
ON		
OFF		

REAR BRAKE LIGHT SWITCH

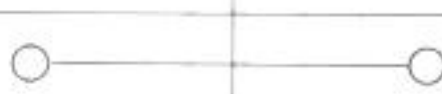
Wire color	R/BI	O/G
OFF		
ON		

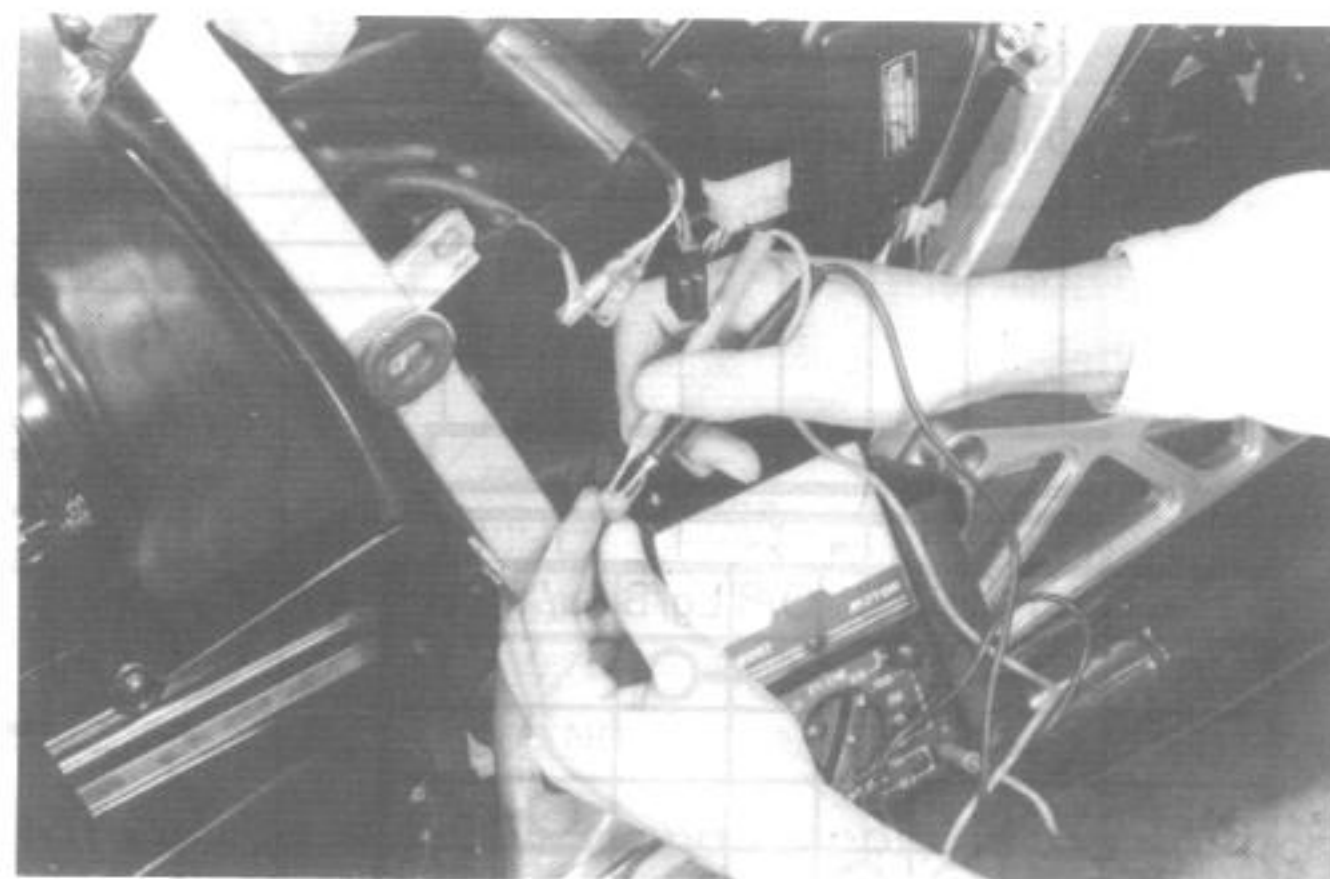
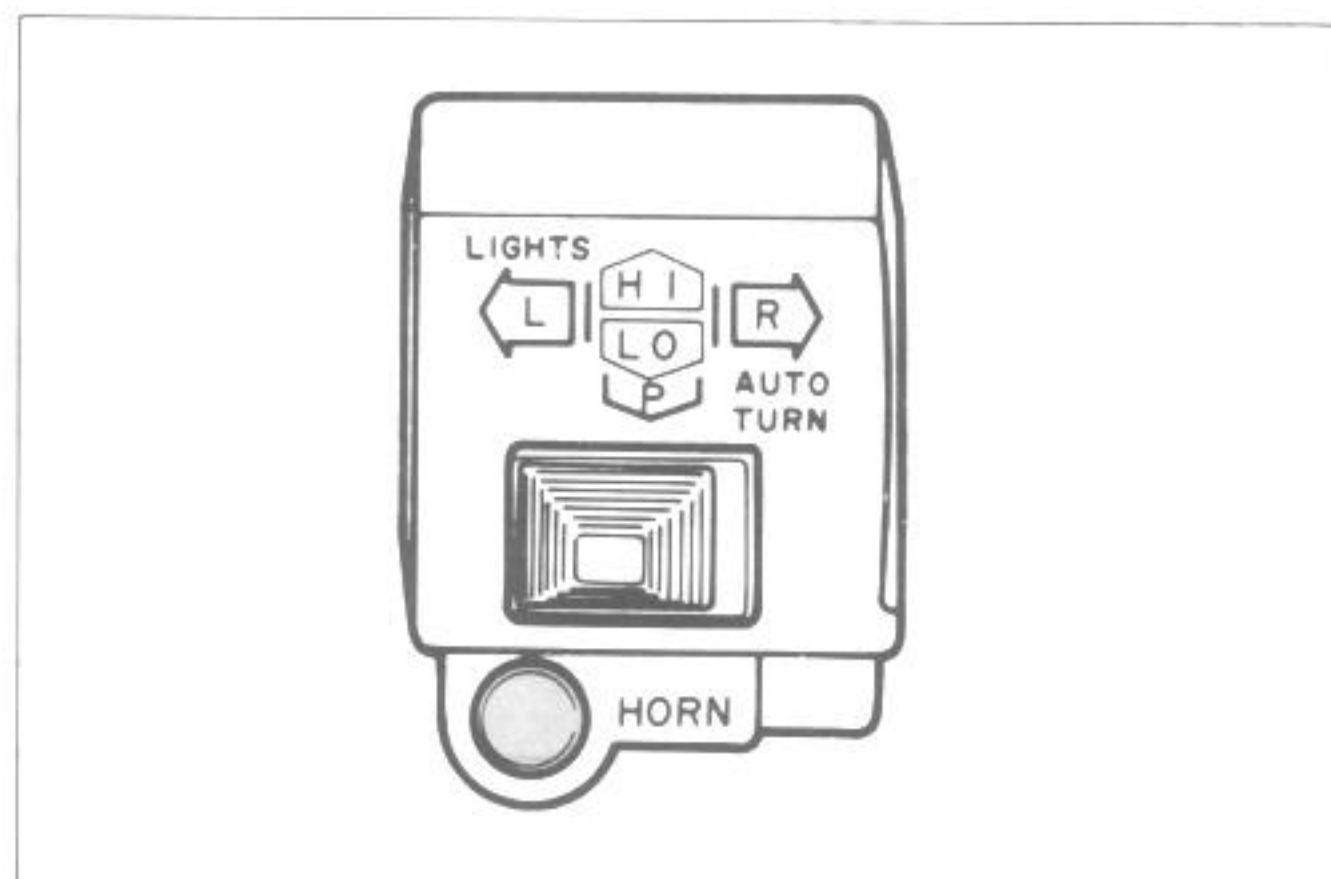
**OIL PRESSURE LIGHT SWITCH**









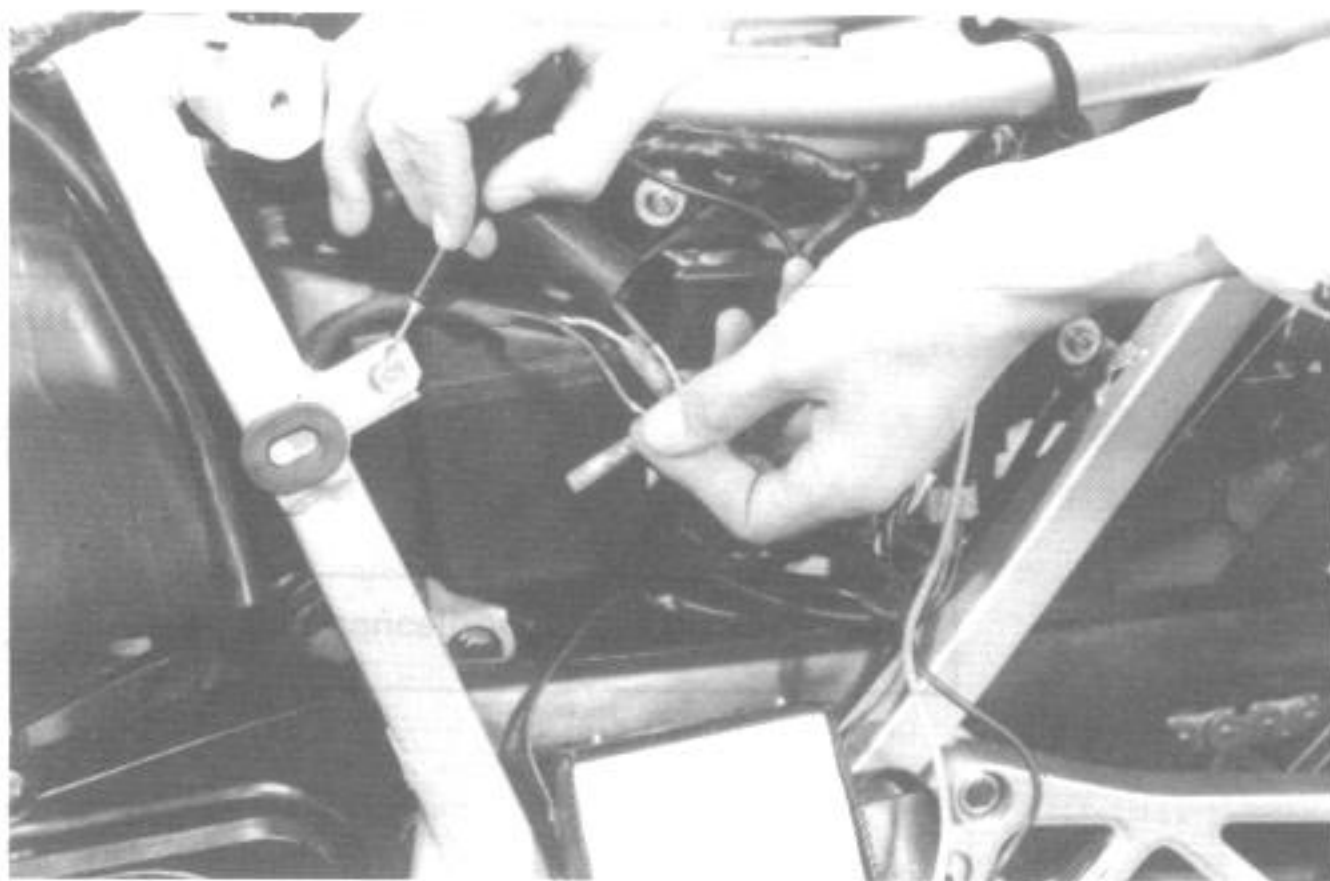



Continuity, when engine is stopped.

No continuity, when engine is running.

NOTE:

Before inspecting the oil pressure switch, check the engine oil level at inspection window.

**GEAR POSITION INDICATOR LIGHT SWITCH**

Wire color	W	R	G	Y	Br	Bl	Ground
Low							
2nd							
3rd							
4th							
Top							
Neutral							



SELF CANCELLING DEVICE (NOT EQUIPPED FOR E-22)

DESCRIPTION

The turn signal light self cancelling device attached to this motorcycle functions as the way the following diagram shows, and it is only an added circuit to the ordinary turn signal.

DIAGRAM

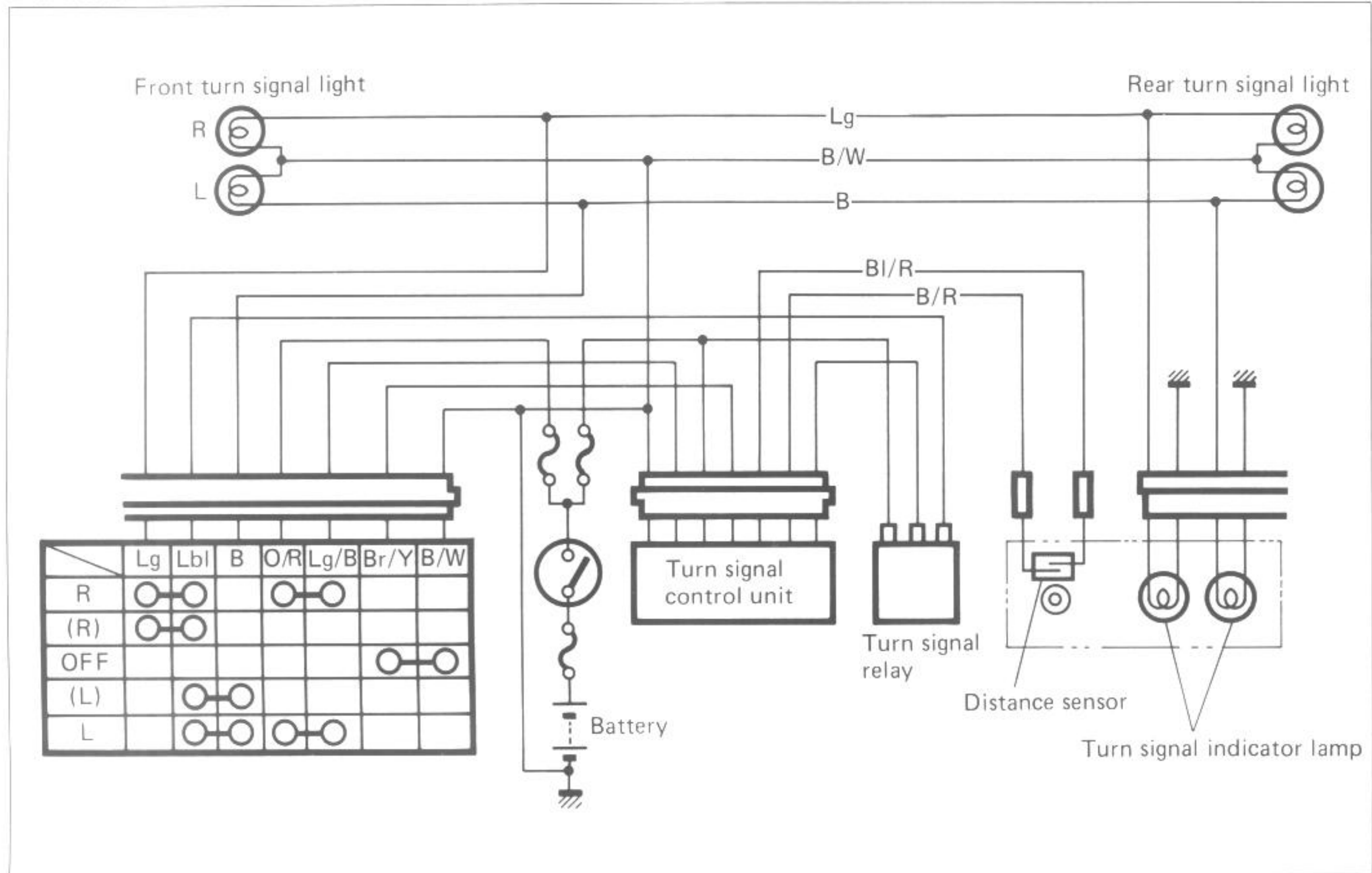

SELF CANCELLING DEVICE FUNCTIONS

TIMER SPECIFICATION:

- * The speed at which the timer starts to run: 15 km/h.
- * The speed at which the timer stops: Less than 12 km/h.
- * The time during which the timer runs: 10 ± 1 seconds (= Time needed for discharge from the condenser.)
- * The timer calculates the amount of condenser discharge. Once the timer stops at the level before the complete discharge from the condenser, it restarts at this level; i.e. the condenser is partially discharged.

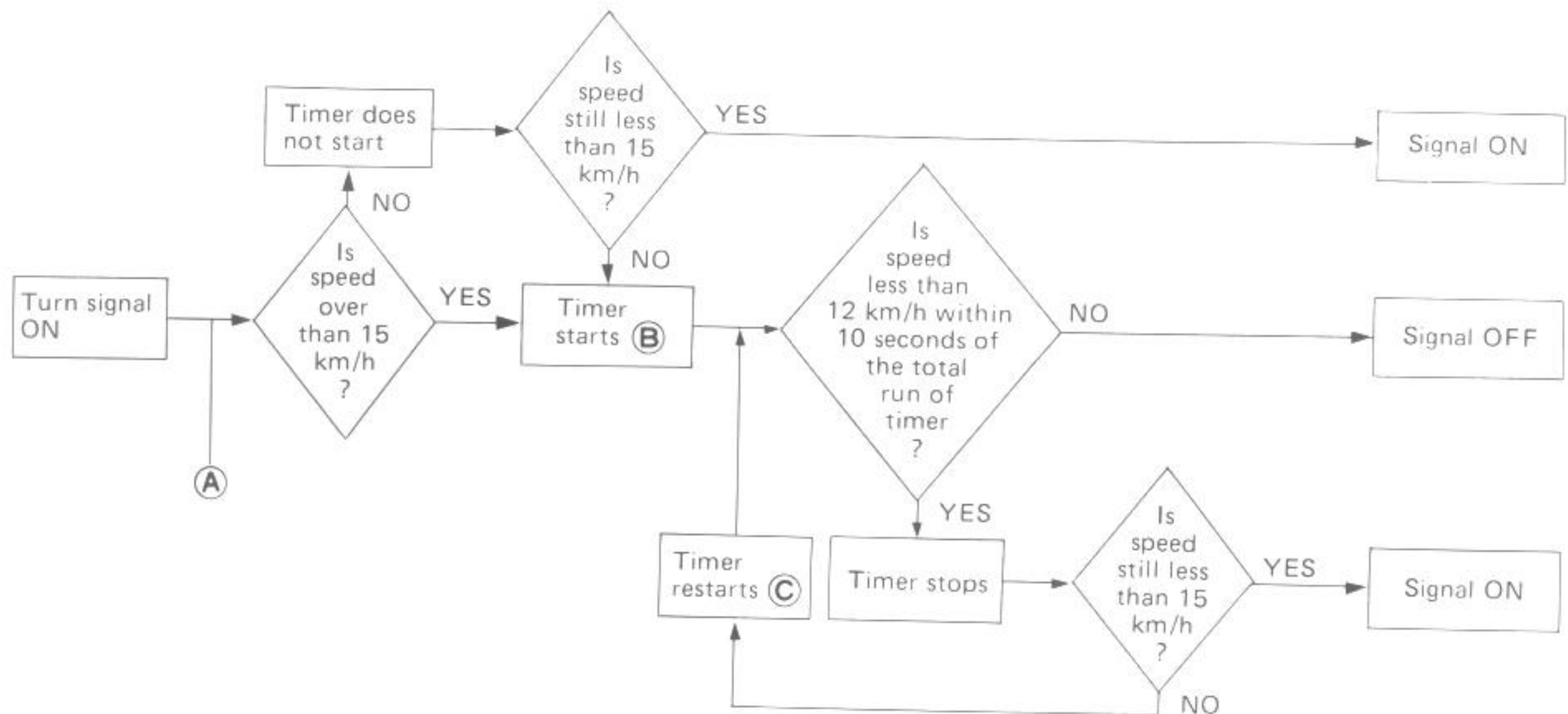

- (A) After the turn signal is on, any change of the switch cancels the device and reapply for the switch begins at this position again.
- (B) At the level that the condenser is fully charged.
- (C) At the level that the condenser is partially discharged.

INSPECTION

If the self cancelling device does not show the proper function. Check the device by the following steps.

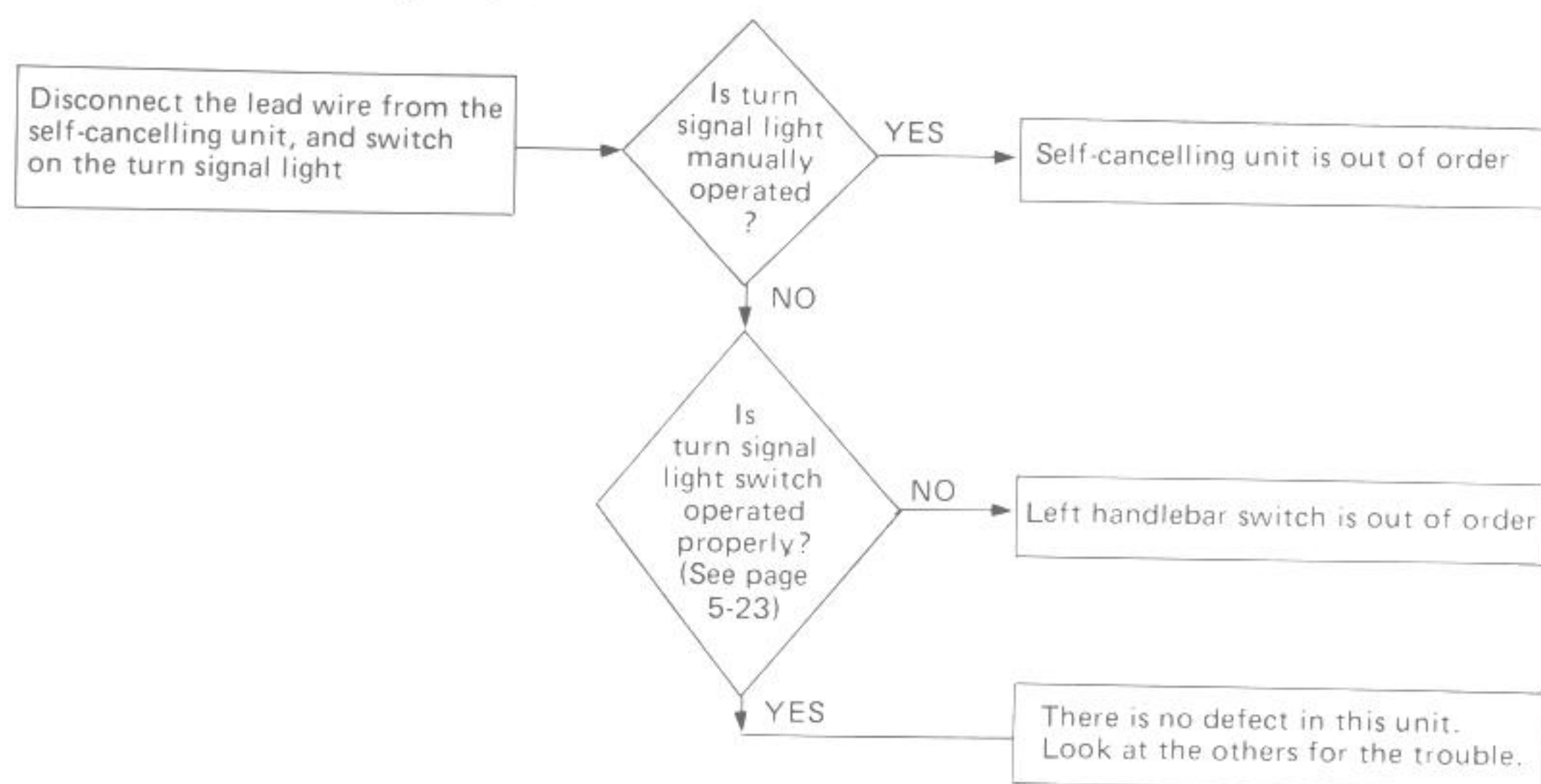

CAUTION:

Be sure to confirm that 1) battery is fully charged, 2) bulbs are standard wattage, and 3) wiring connection is tight before inspecting self-cancelling device.

BATTERY

SPECIFICATIONS

Type designation	SYB14L-B2
Capacity	12V, 50.4 kC (14 Ah)/ 10 HR
Standard electrolyte S.G.	1.28 at 20°C

In fitting the battery to the motorcycle, connect the breather tube to the battery vent.

INITIAL CHARGING

Filling electrolyte

Remove short sealed tube before filling electrolyte. Fill battery with electrolyte (dilute sulfuric acid solution with acid concentration of 35.0% by weight, having a specific gravity of 1.28 at 20°C (68°F) up to indicated MAX. LEVEL. Filling electrolyte should be always cooled below 30°C (86°F) before filling into battery. Leave battery standing for half an hour after filling. Add additional electrolyte if necessary.

Charge battery with current as described in the tables shown below.

Maximum charging current	1.4 A
--------------------------	-------

Charging time

The charging time for a new battery is determined by the number of months that have elapsed since the date of manufacture.

Date of manufacture is indicated by a three-part number ①, as follows, each indicating month, date and year.

Near the end of charging period, adjust the specific gravity of electrolyte to value specified. After charging, adjust the electrolyte level to the MAX. LEVEL with DISTILLED WATER.

SERVICING

Visually inspect the surface of the battery container. If any signs of cracking or electrolyte leakage from the sides of the battery have occurred, replace the battery with a new one.

If the battery terminals are found to be coated with rust or an acidic white powder substance, then this can be cleaned away with emery paper.

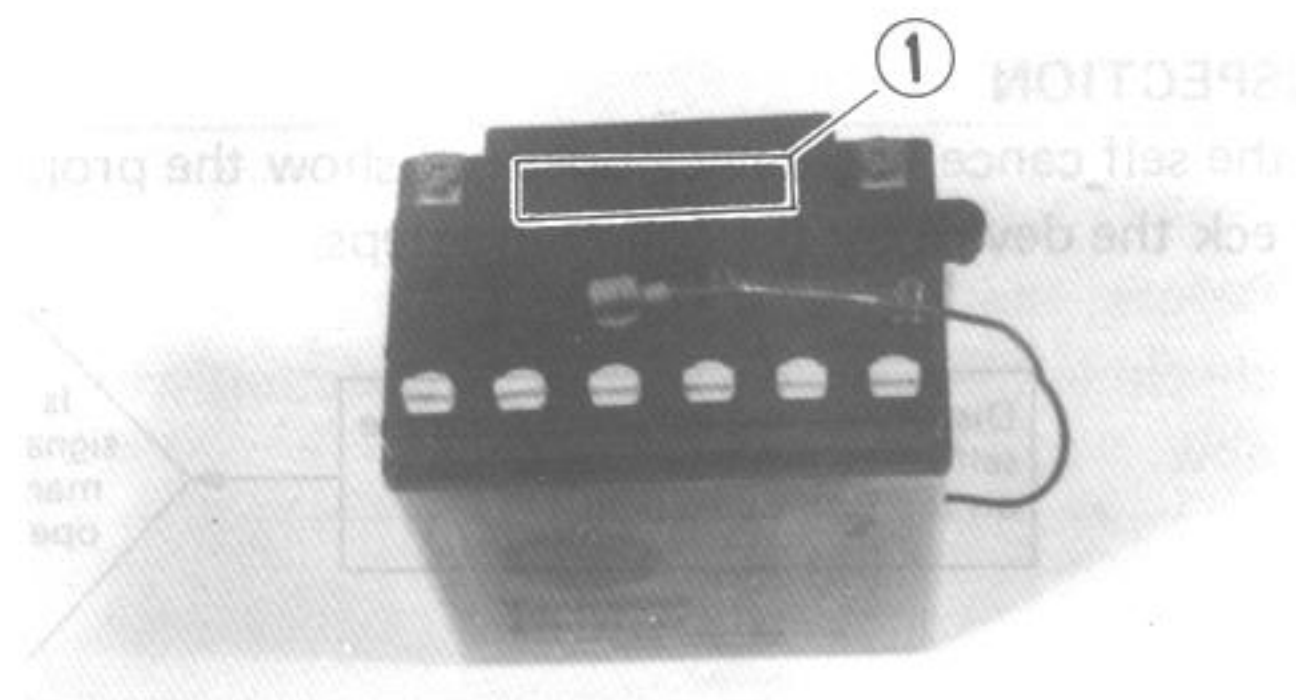
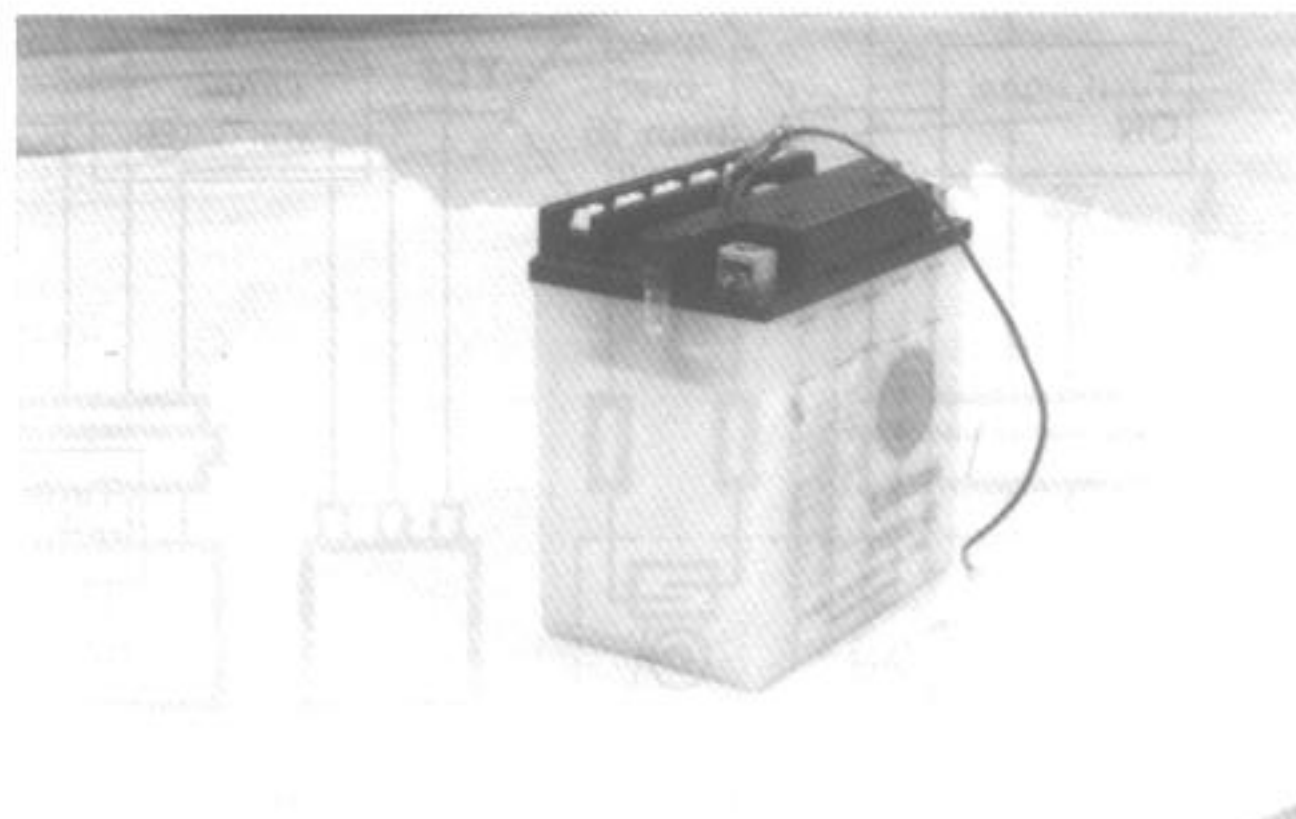
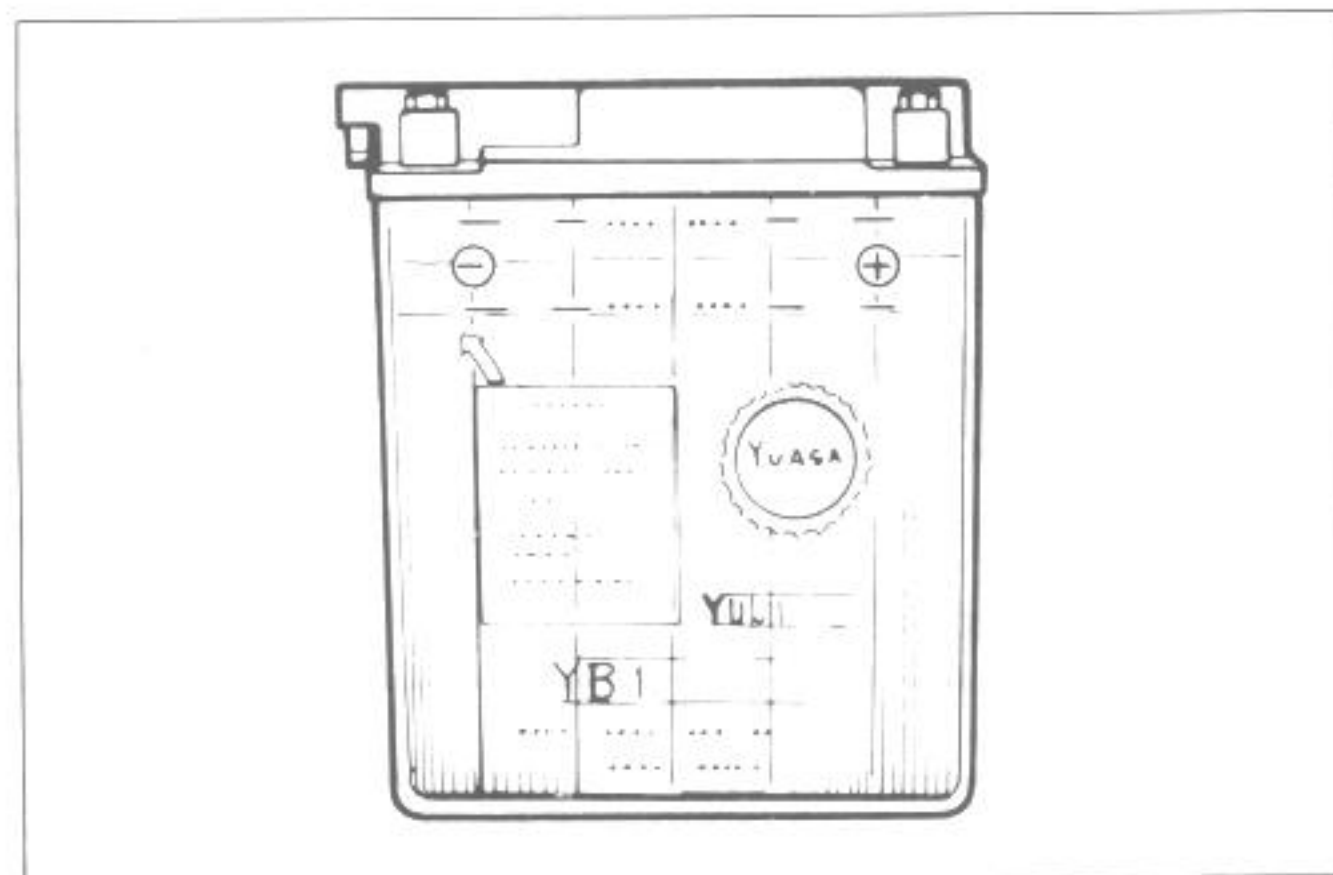

Months after manufacturing	Within 6	Within 9	Within 12	Over 12
Necessary charging hours	20	30	40	60

Check the electrolyte level and add distilled water, as necessary, to raise the electrolyte to each cell's upper level.

Check the battery for proper charge by taking an electrolyte S.G. reading. If the reading is 1.22 or less, as corrected to 20°C (68°F), it means that the battery is still in a discharged condition and needs recharging.

BASED ON S.G. READING RECHARGING OPERATION

To correct an S.G. reading 20°C (68°F), use the table at the right.

To read the S.G. on the hydrometer, bring the electrolyte in the hydrometer ① to eye level and read the graduations on the float scale bordering on the meniscus (curved-up portion of electrolyte surface), as shown in figure.

Check the reading (as corrected to 20°C) with chart to determine the recharging time in hours by constant-current charging at a charging rate of 1.4 amperes (which is a tenth of the capacity of the present battery).

Be careful not to permit the electrolyte temperature to exceed 45°C (113°F), at any time, during the recharging operation. Interrupt the operation, as necessary, to let the electrolyte cool down. Recharge the battery to the specification.

Electrolyte specific gravity	1.28 at 20°C (68°F)
------------------------------	---------------------

CAUTION:

Constant-voltage charging, otherwise called "quick" charging, is not recommended as it could shorten the life of the battery.

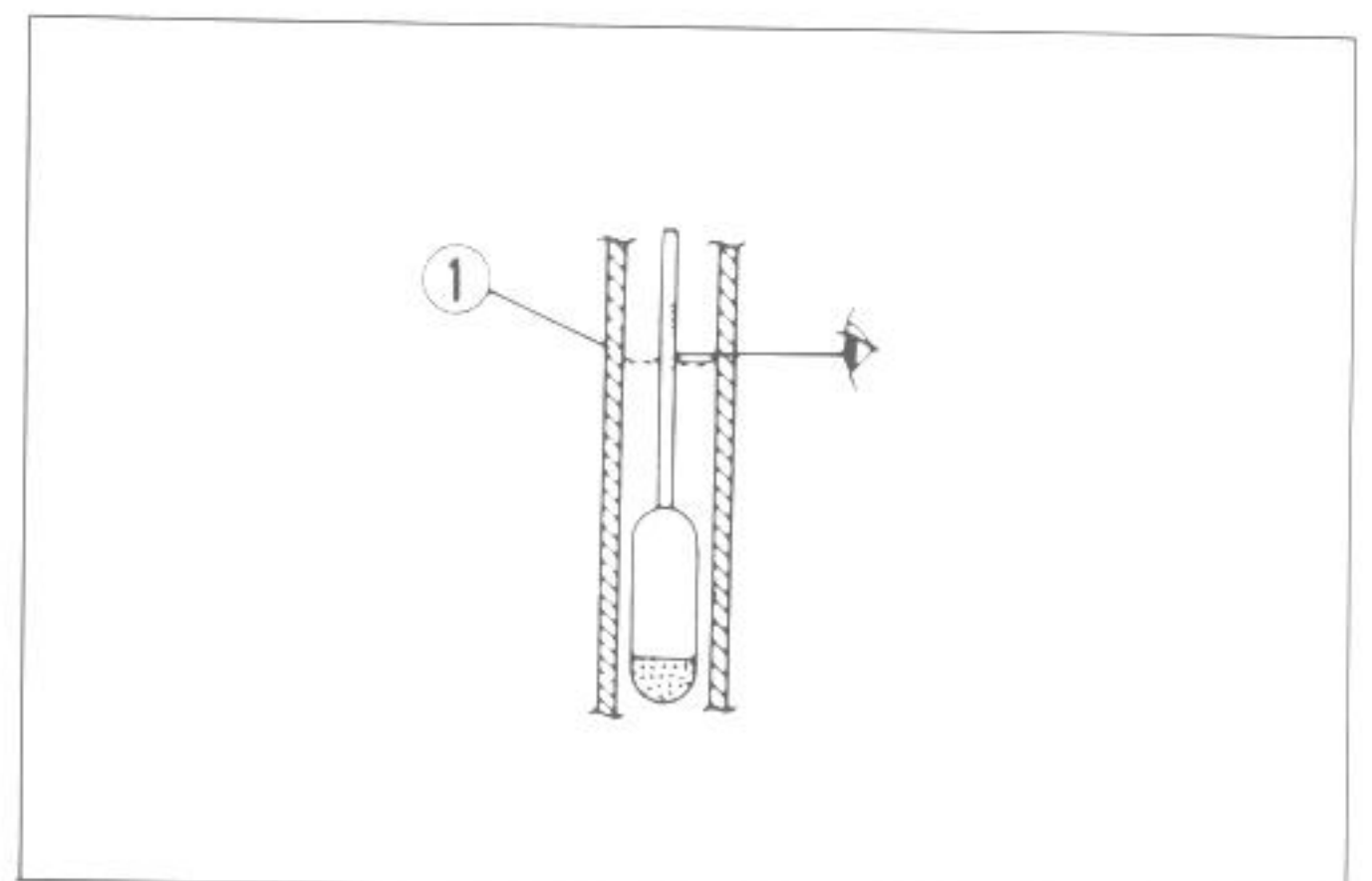
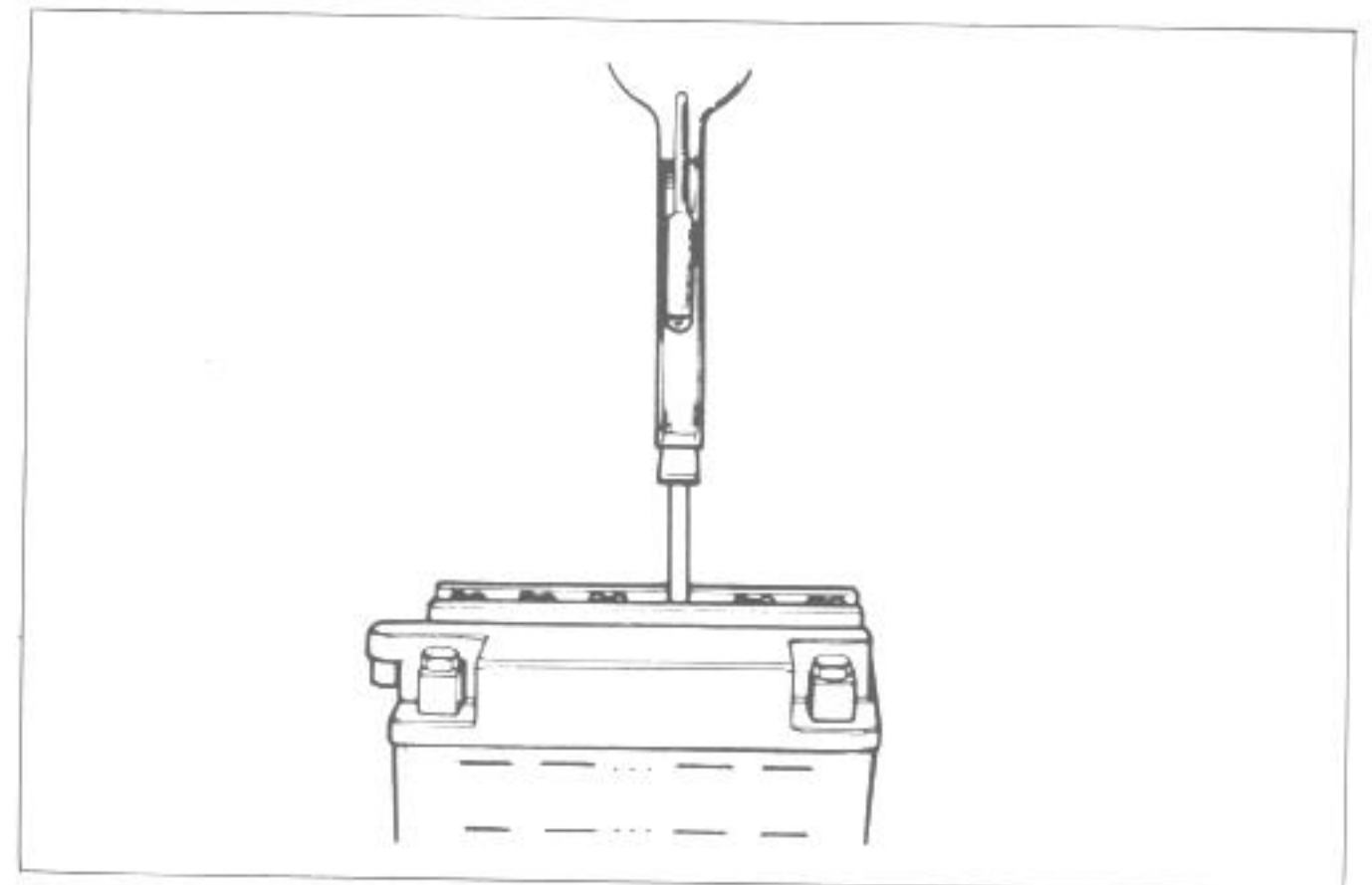
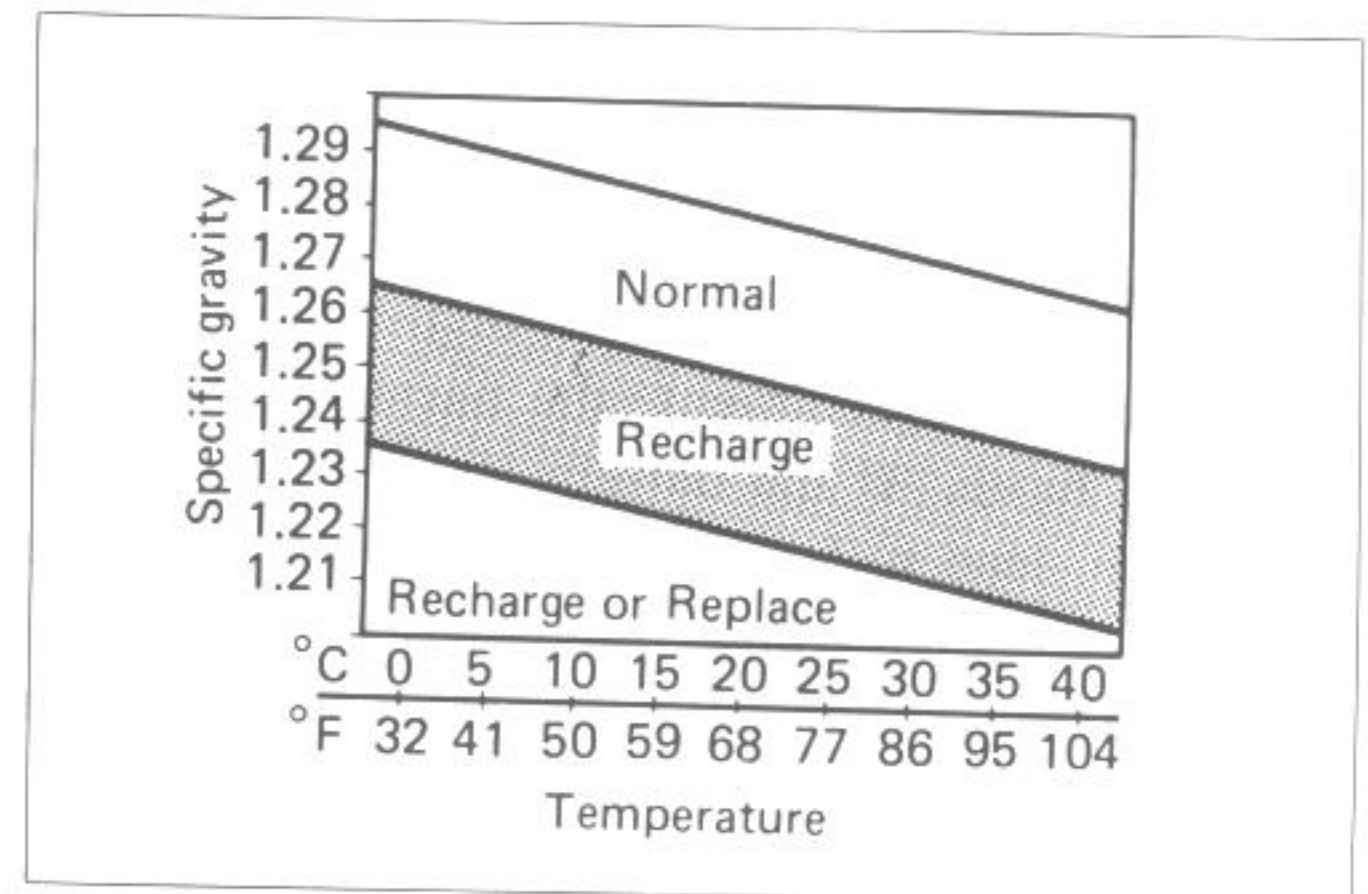
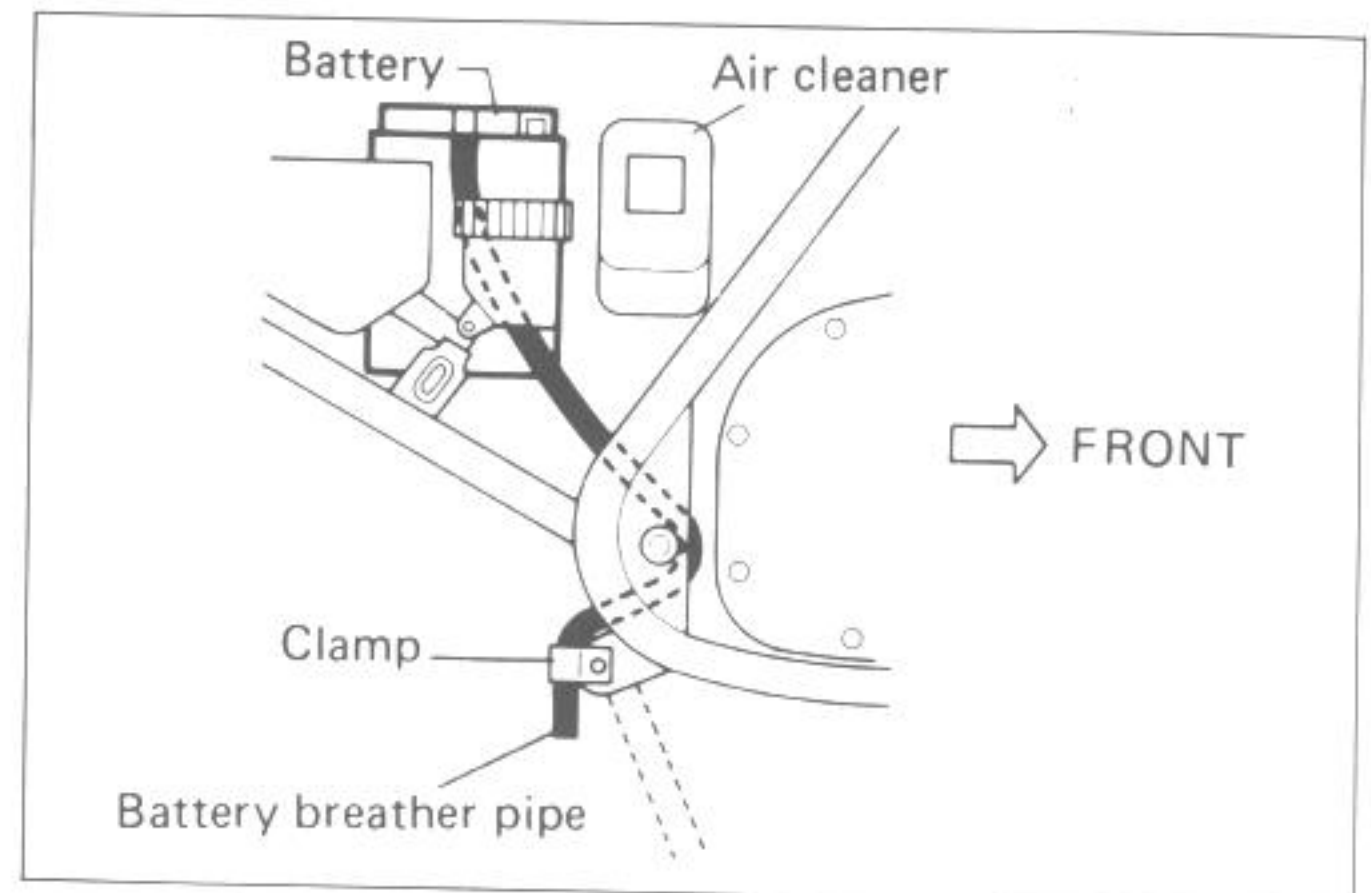

09900-28403

Hydrometer

WARNING:

- * Before charging a battery, remove the seal cap from each cell.
- * Keep fire and sparks away from a battery being charged.
- * When removing a battery from the motorcycle, be sure to remove the \ominus terminal first.

SERVICE LIFE

Lead oxide is applied to the pole plates of the battery which will come off gradually during the service life. When the bottom of the battery case becomes full of sediment, the battery cannot be used any more. If the battery is not charged for a long time, lead sulfate is generated on the surface of the pole plates and will deteriorate the performance (sulfation). Replace the battery with a new one in such a case.

When a battery is left for a long term without use, it is subject to sulfation. When the motorcycle is not used for more than 1 month (especially during the winter season), recharge the battery at least once a month.

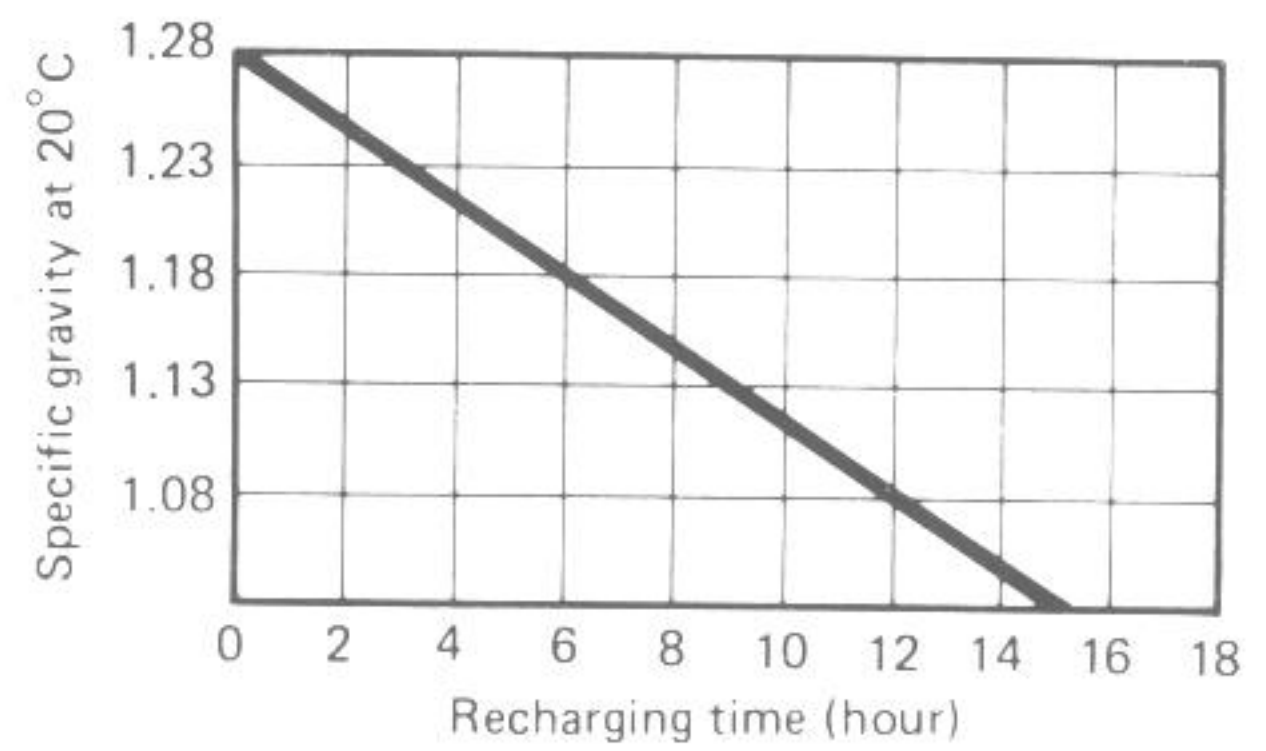

CHASSIS

CONTENTS

<i>FRONT WHEEL</i>	6- 1
<i>FRONT BRAKE</i>	6- 7
<i>FRONT FORK</i>	6-14
<i>STEERING STEM</i>	6-24
<i>REAR BRAKE</i>	6-29
<i>REAR WHEEL</i>	6-35
<i>TIRE AND WHEEL</i>	6-42
<i>REAR SWINGARM AND SUSPENSION</i>	6-48

FRONT WHEEL

CONSTRUCTION

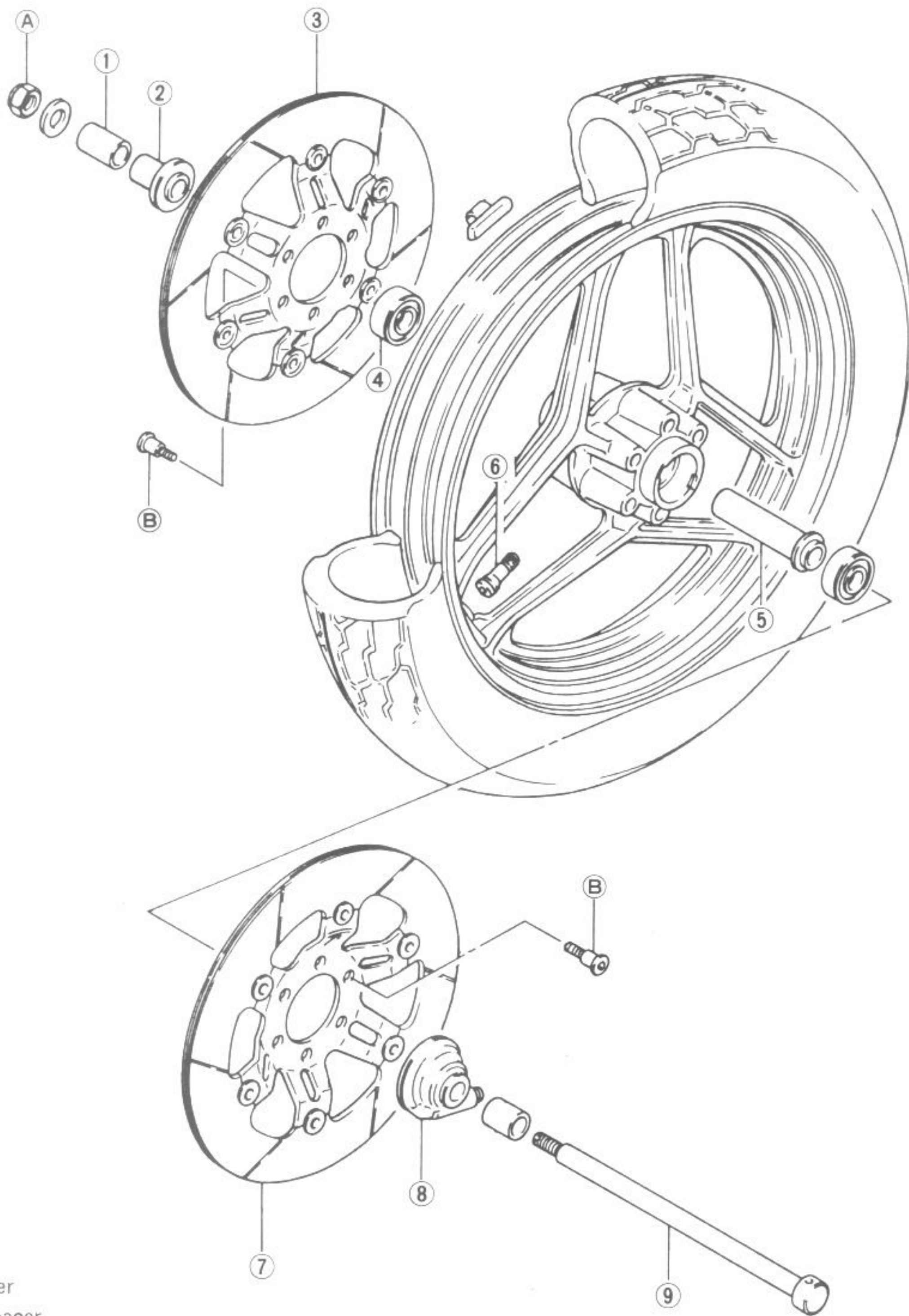

- ① Axle spacer
- ② Bearing spacer
- ③ Disc (R)
- ④ Wheel bearing
- ⑤ Spacer
- ⑥ Air valve
- ⑦ Disc (L)
- ⑧ Speedometer gearbox
- ⑨ Axle shaft

Tightening torque		
	N·m	kg·m
Ⓐ	36 – 52	3.6 – 5.2
Ⓑ	15 – 25	1.5 – 2.5

REMOVAL AND DISASSEMBLY

- Support the machine by center stand and jack.



- Disconnect the speedometer cable ① and dismount the right and left calipers.

NOTE:

Do not operate the brake lever while dismounting the calipers.

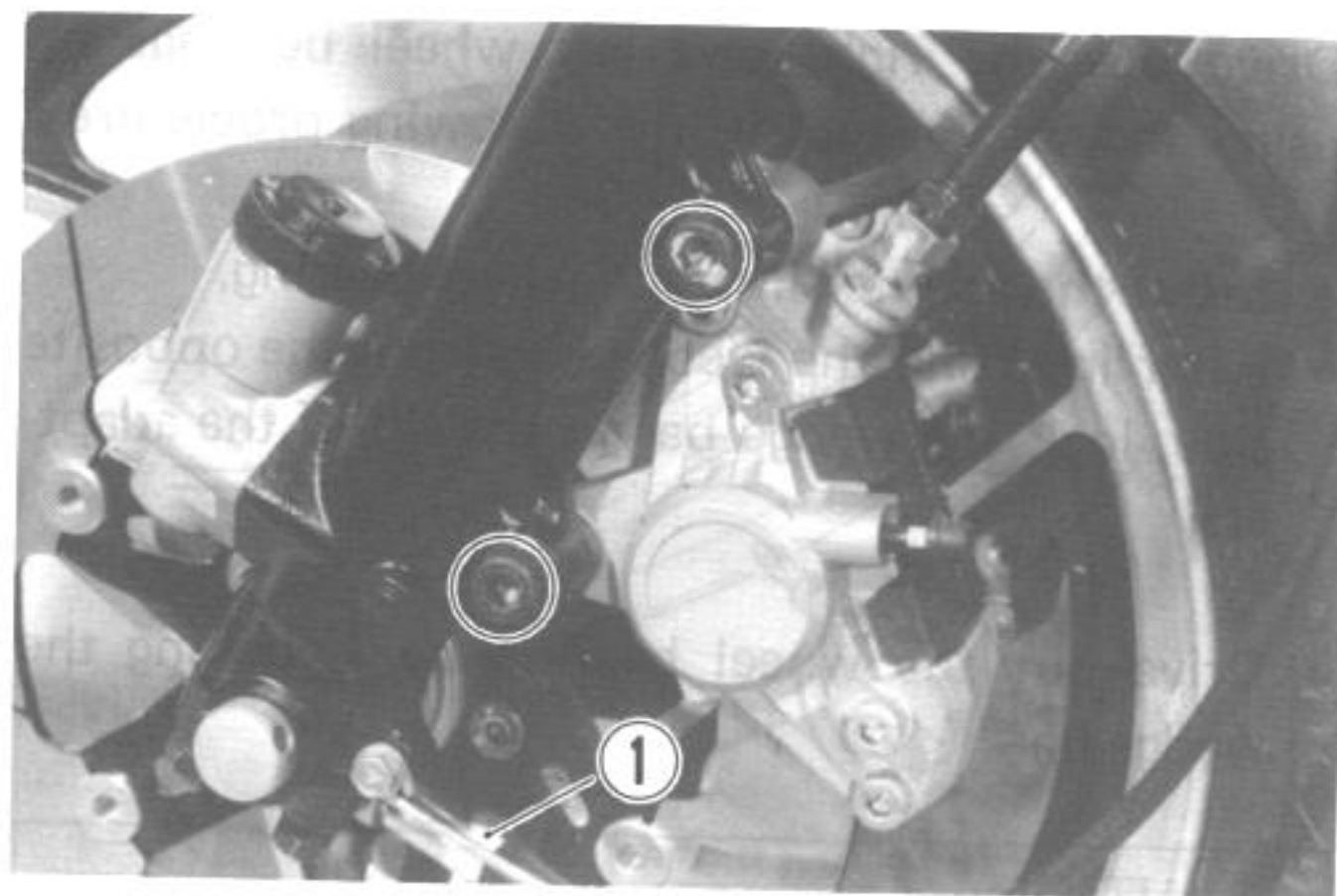

- Remove the axle nut and pull out the front axle.

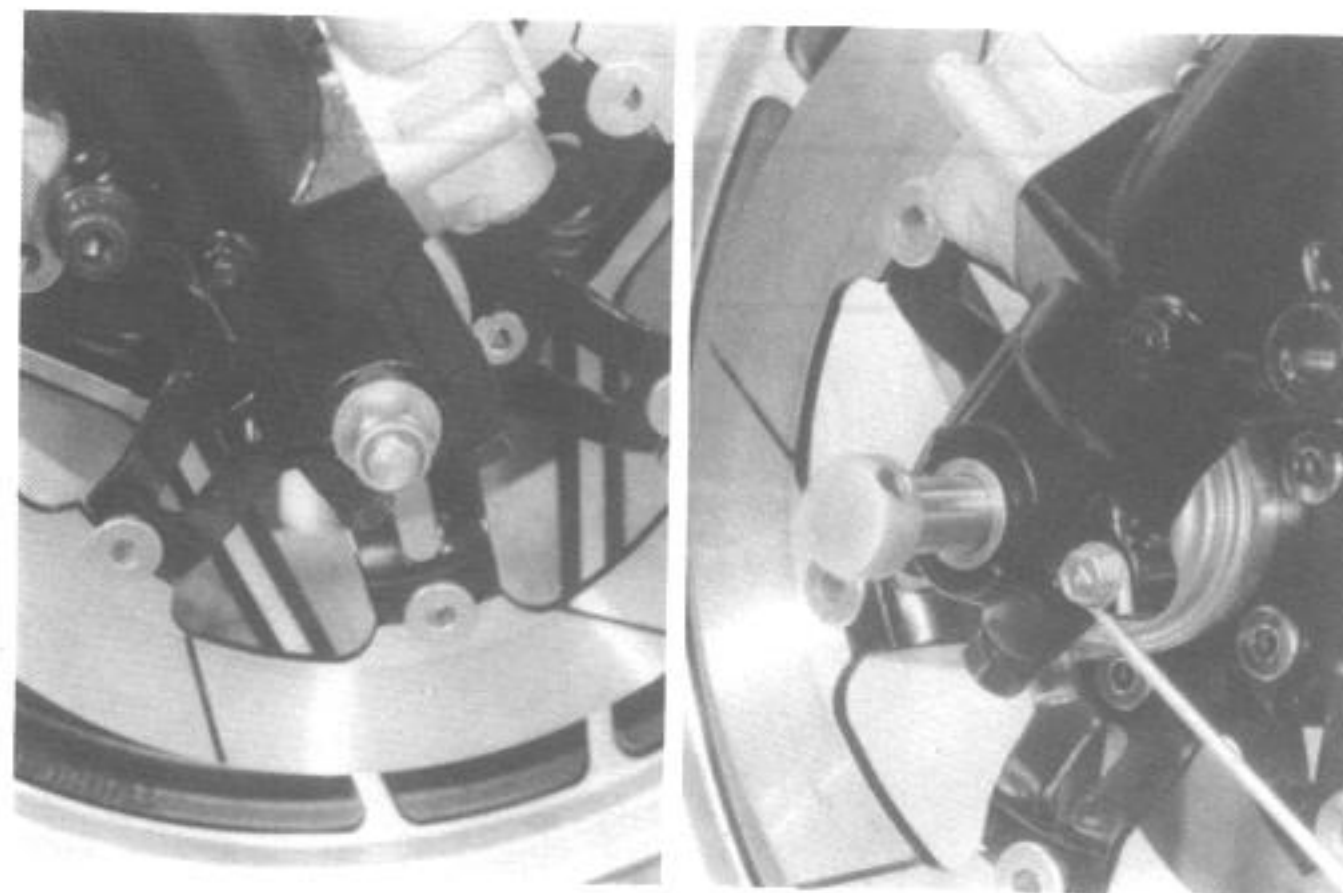

- Remove the front wheel.

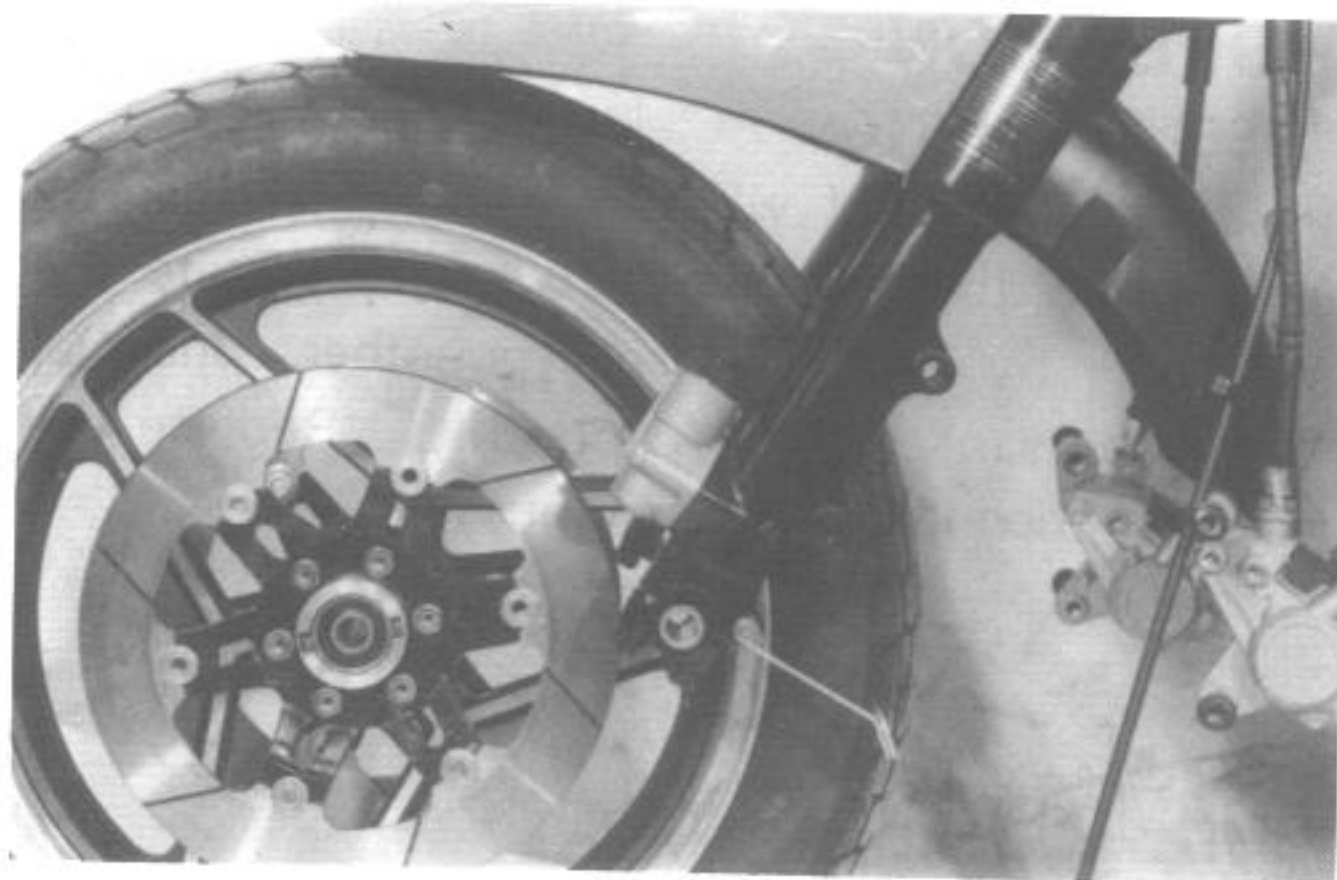

- Remove the securing bolts and separate both discs from wheel.

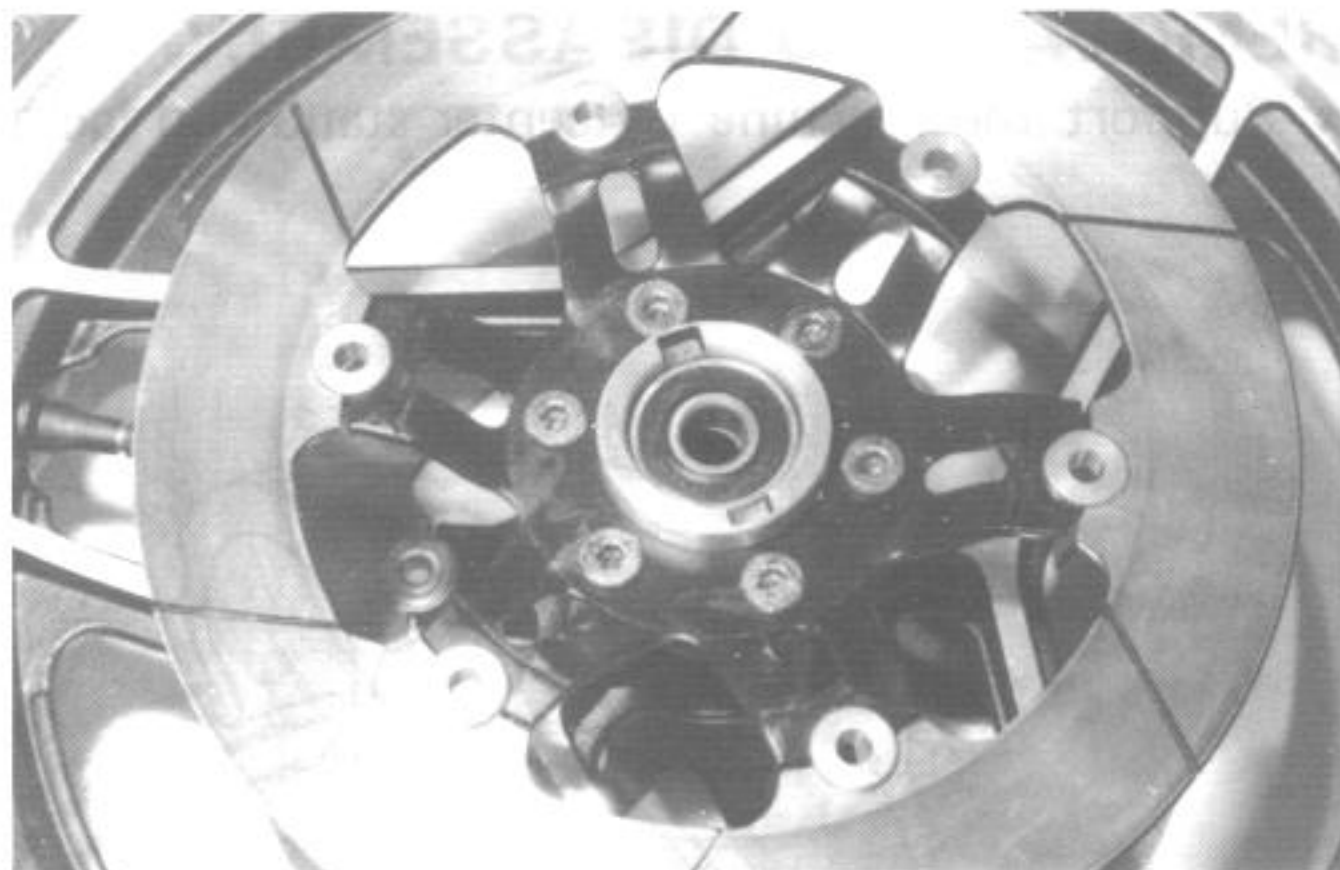

Drive out the right and left wheel bearings by using the special tool in the following procedures.

- Insert the adapter into the wheel bearing.
- After inserting the wedge bar from the opposite side, lock the wedge bar in the slit of the adapter.
- Drive out the wheel bearing by knocking the wedge bar.

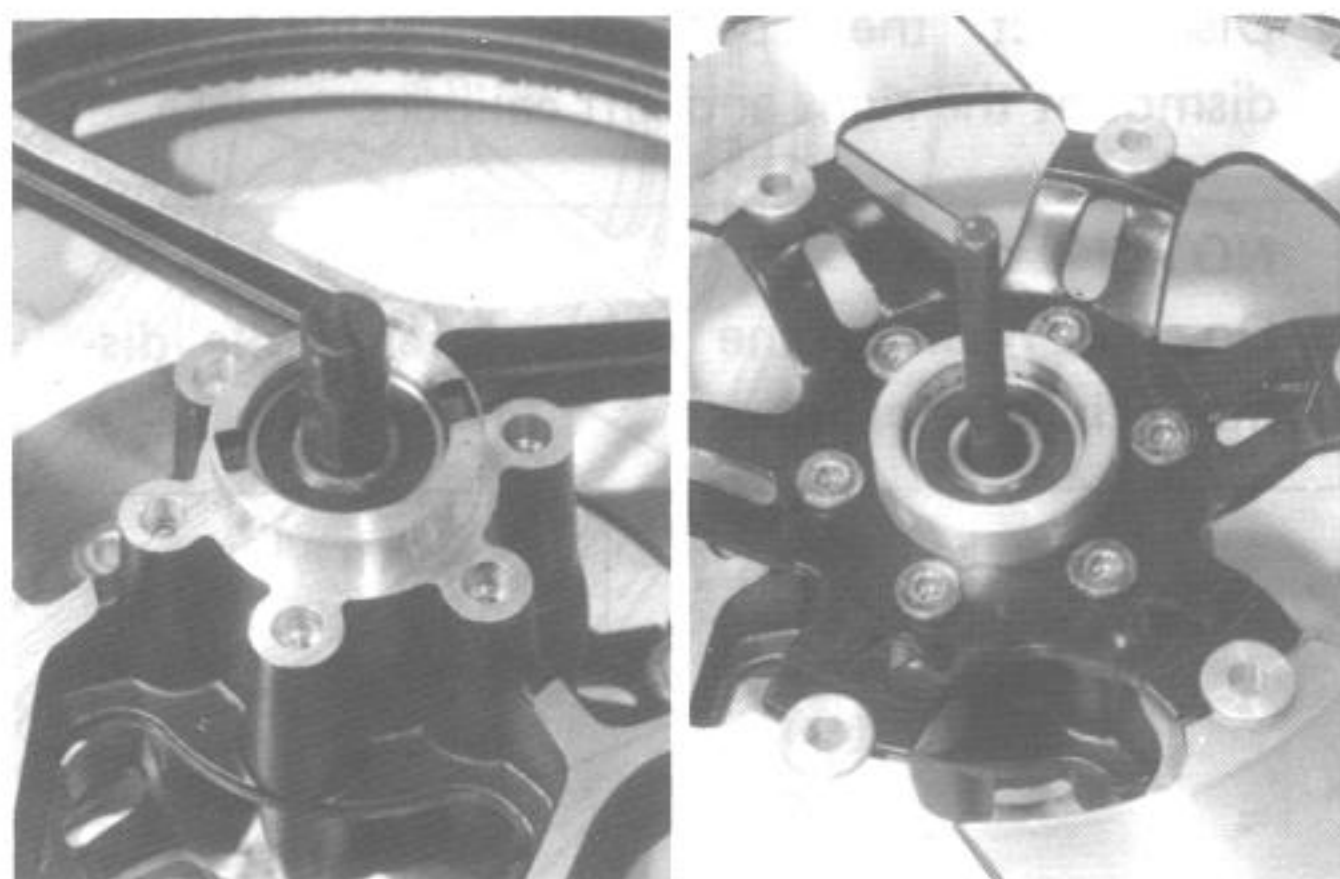

CAUTION:

The removed bearing should be replaced.

09941-50110

Bearing remover

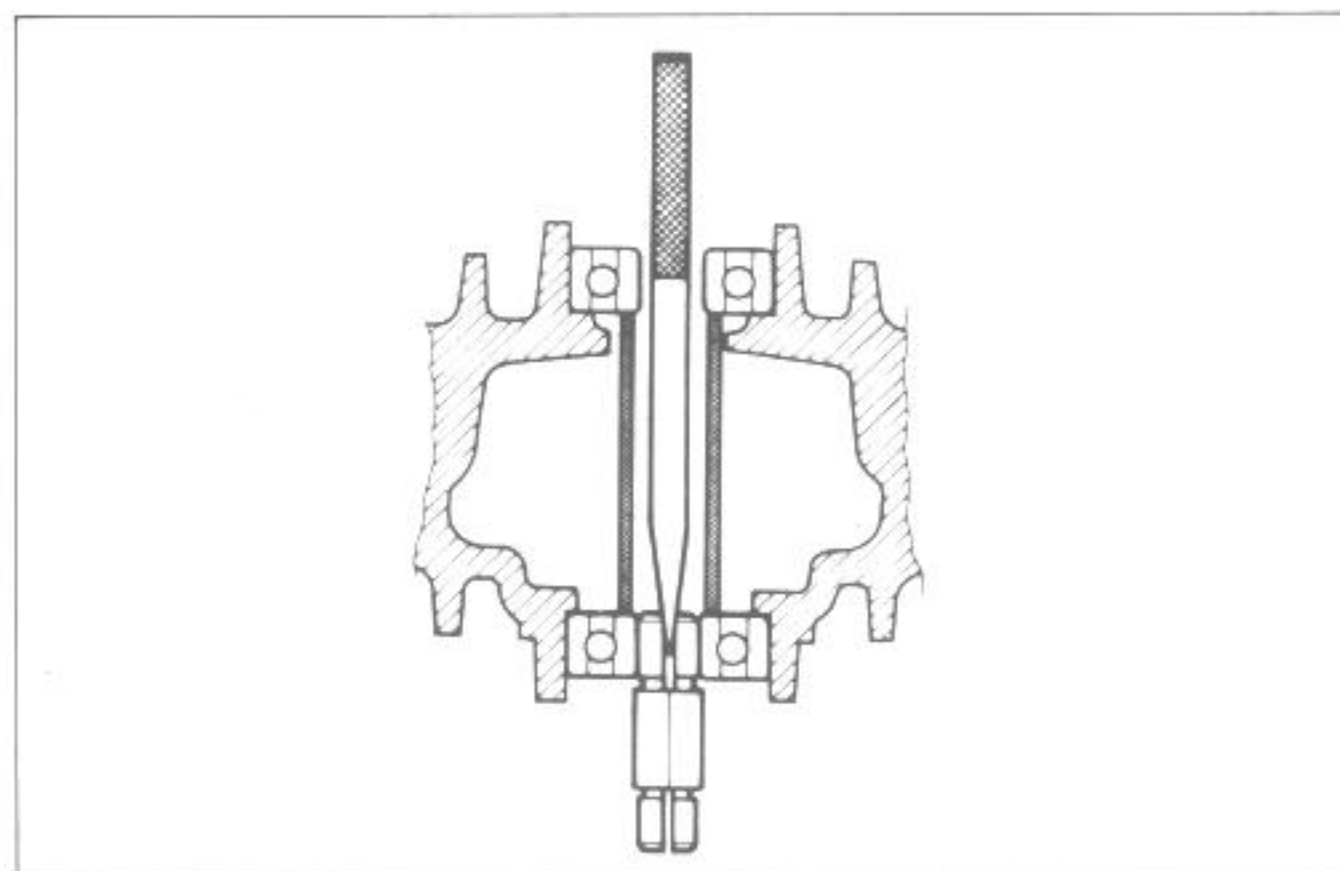

INSPECTION

WHEEL BEARINGS

Inspect the play of wheel bearing inner race by hand while fixing it in the wheel. Rotate the inner race by hand to inspect whether abnormal noise occurs or rotating smoothly. Replace the bearing if there is something unusual.

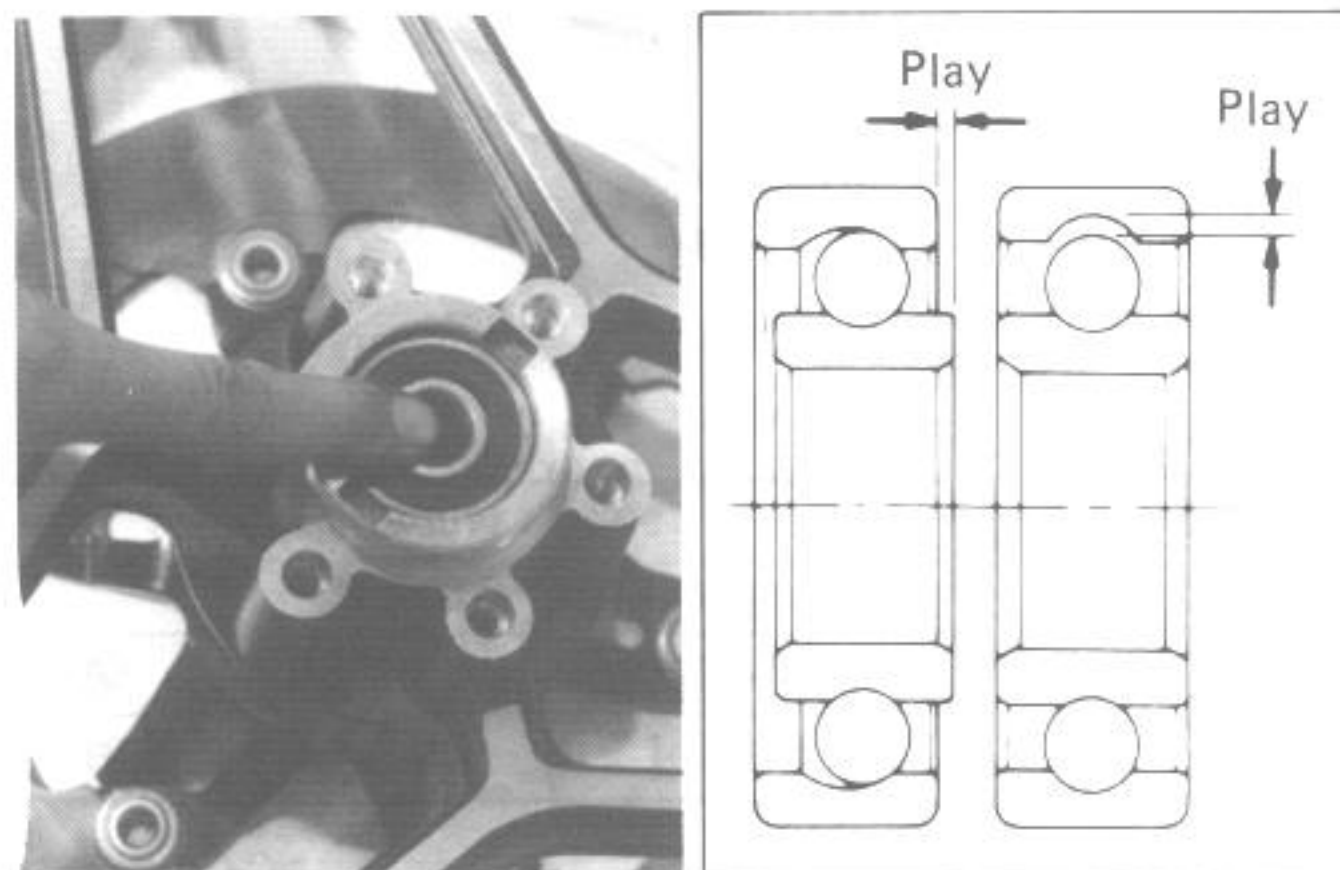

AXLE SHAFT

Using a dial gauge, check the axle shaft for runout and replace it if the runout exceeds the limit.

09900-20606	Dial gauge (1/100)
09900-20701	Magnetic stand

Service Limit	0.25 mm
---------------	---------

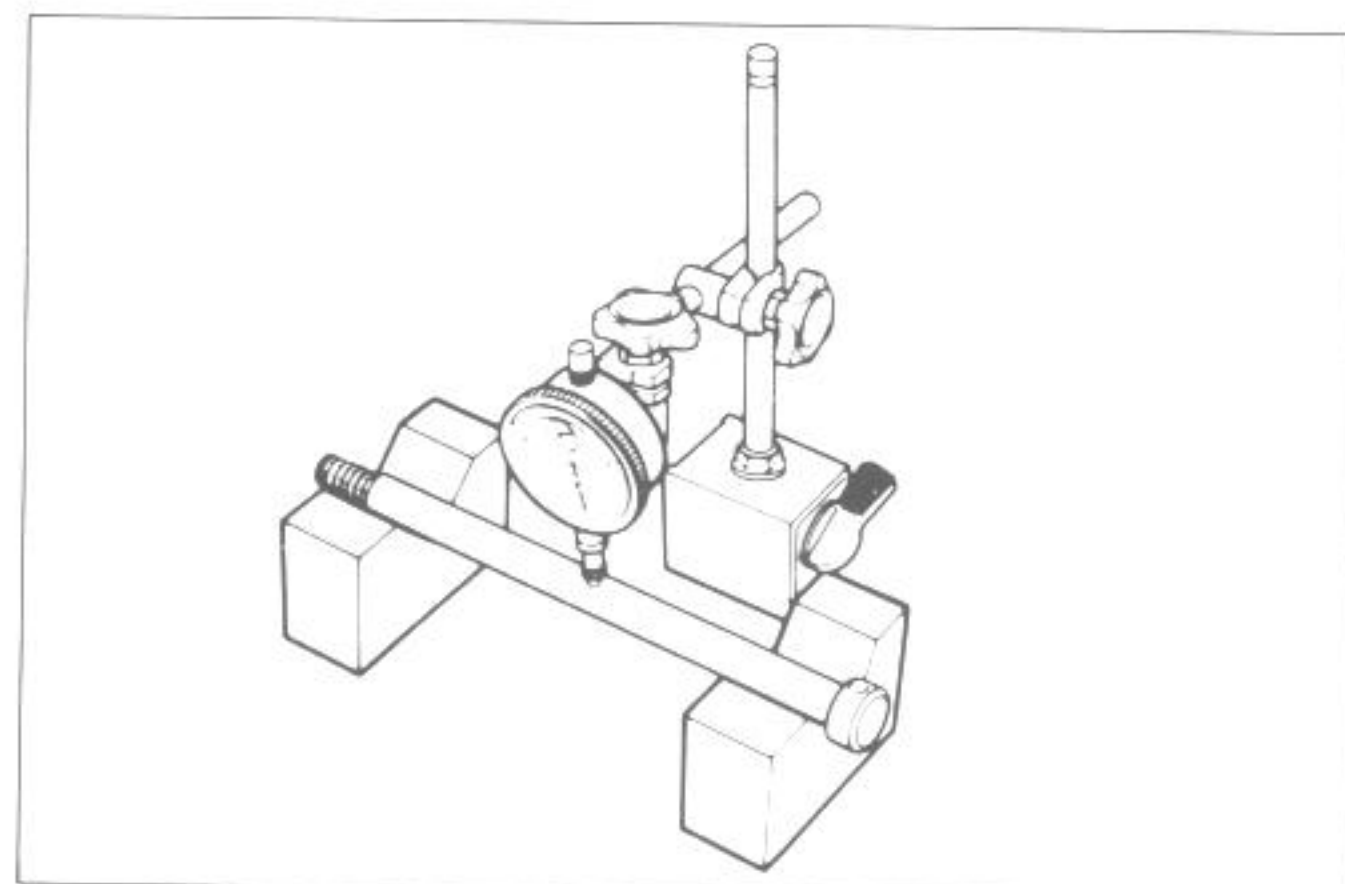
**WHEEL**

Make sure that the wheel runout checked as shown does not exceed the service limit. An excessive runout is usually due to worn or loose wheel bearings and can be reduced by replacing the bearings. If bearing replacement fails to reduce the runout, replace the wheel.

Service Limit (Axle and Radial)	2.0 mm
------------------------------------	--------

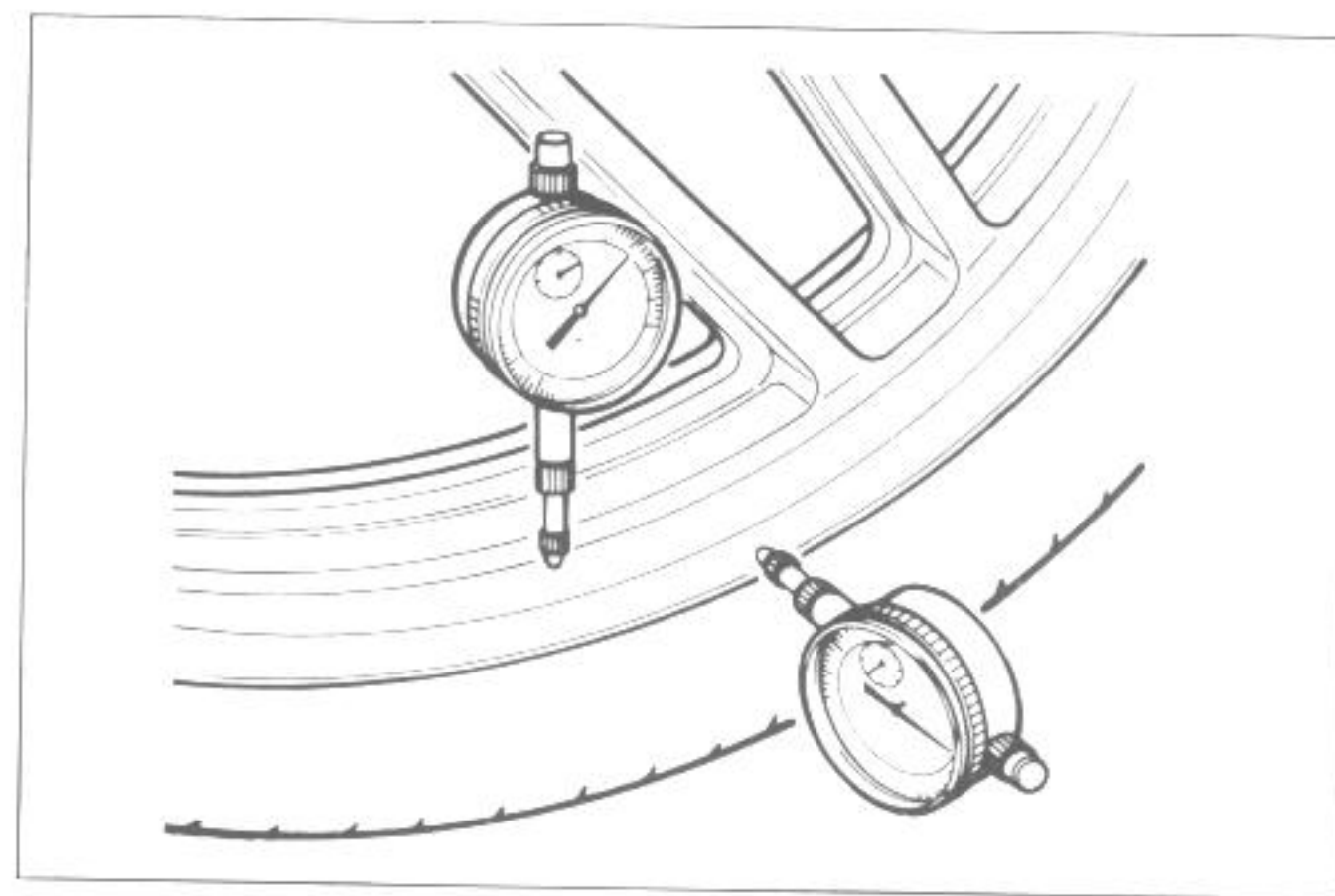
**REASSEMBLY**

Reassemble and remount the front wheel in the reverse order of disassembly and removal, and also carry out the following steps:

WHEEL BEARING

Apply grease to the bearing before installing the bearings.

99000-25010	SUZUKI Super grease "A"
-------------	-------------------------

Install the wheel bearings as follows by using the special tool.

CAUTION:
First install the wheel bearing for left side.

09924-84510	Bearing installer set
-------------	-----------------------

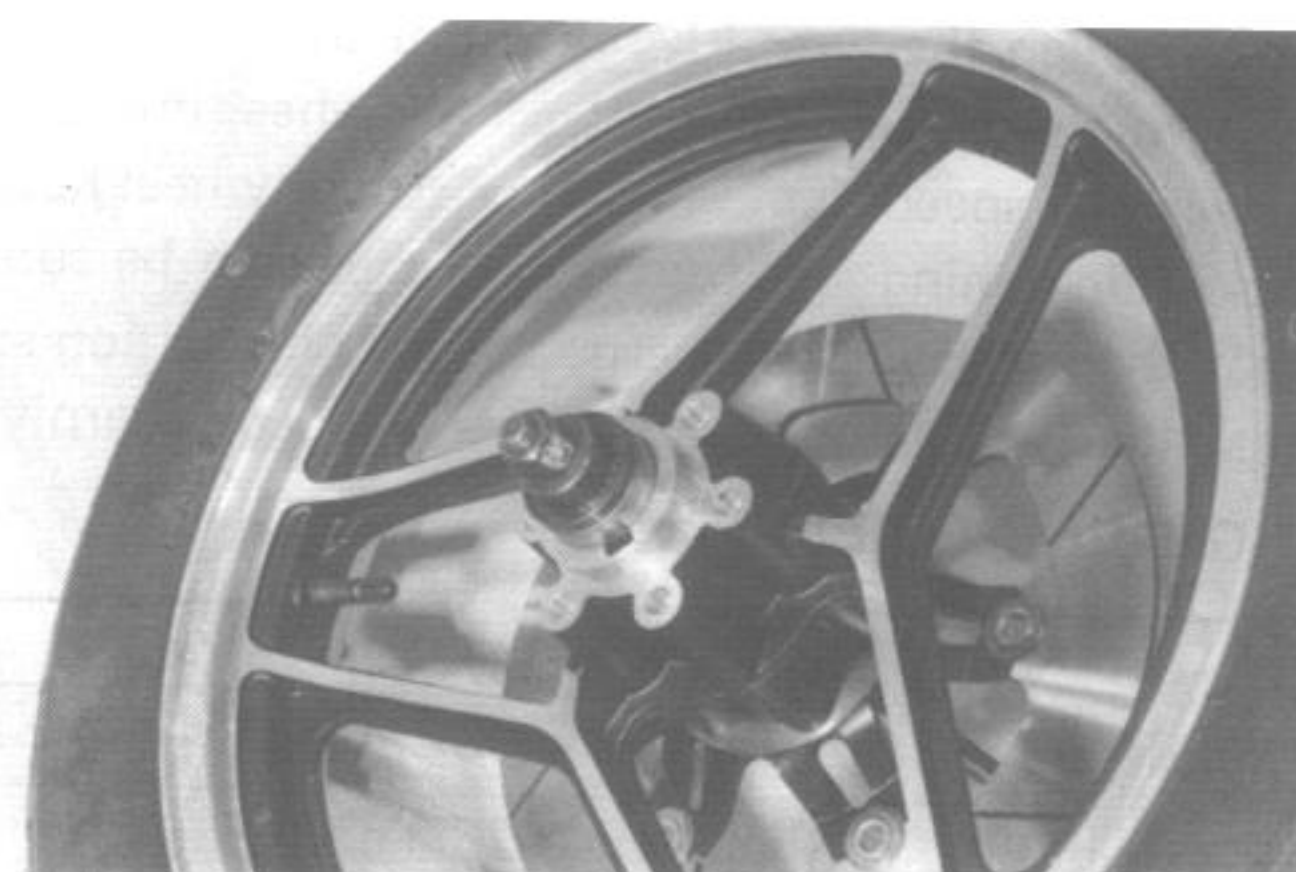
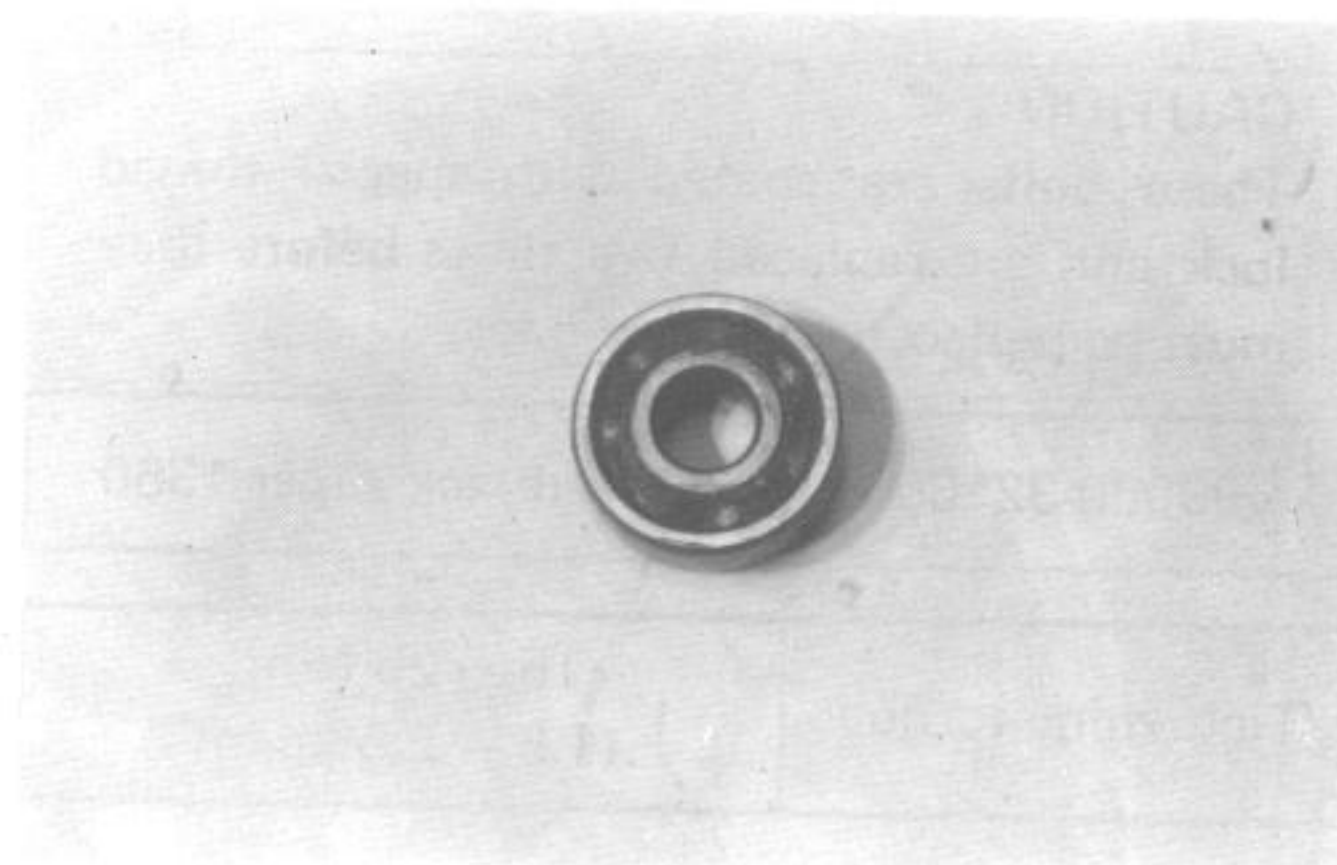

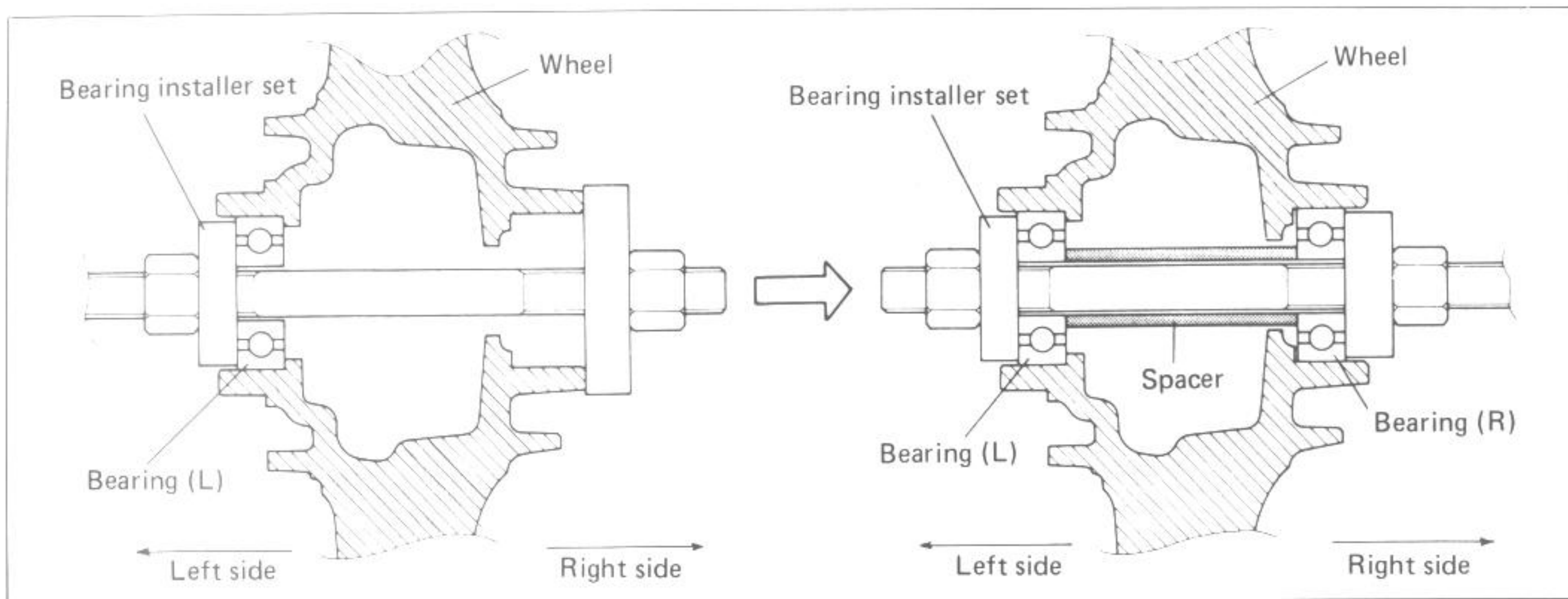

BRAKE DISC

Mount each brake disc properly according to the groove on the plate surface and turning direction.

Make sure that the brake disc is clean and free of any greasy matter. Tighten them to the specified torque.

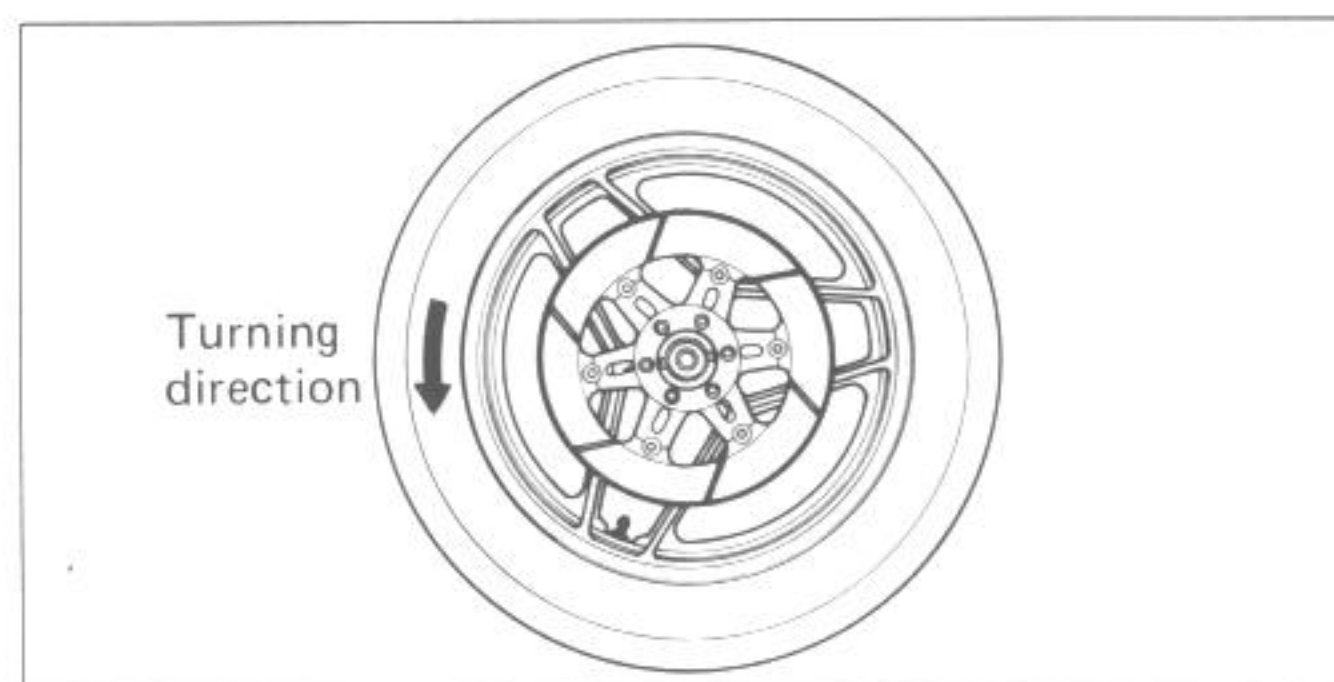

CAUTION:

These bolts are coated with special thread lock and are replaced five times before they must be replaced with new ones.

99000-32130

Thread lock super 1360

Tightening torque

15 – 25 N·m
(1.5 – 2.5 kg-m)

Before installing the speedometer gearbox, grease it and align the two drive pawls of the drive gearbox to the two recesses ① of the wheel hub and attach the speedometer gearbox to the wheel hub. When tightening the front axle, check to be sure that the speedometer gearbox is in the position so that the speedometer cable does not bend sharply.

TIGHTENING TORQUE

	N·m	kg-m
Axle nut	36 – 52	3.6 – 5.2
Axle holder nut	15 – 25	1.5 – 2.5

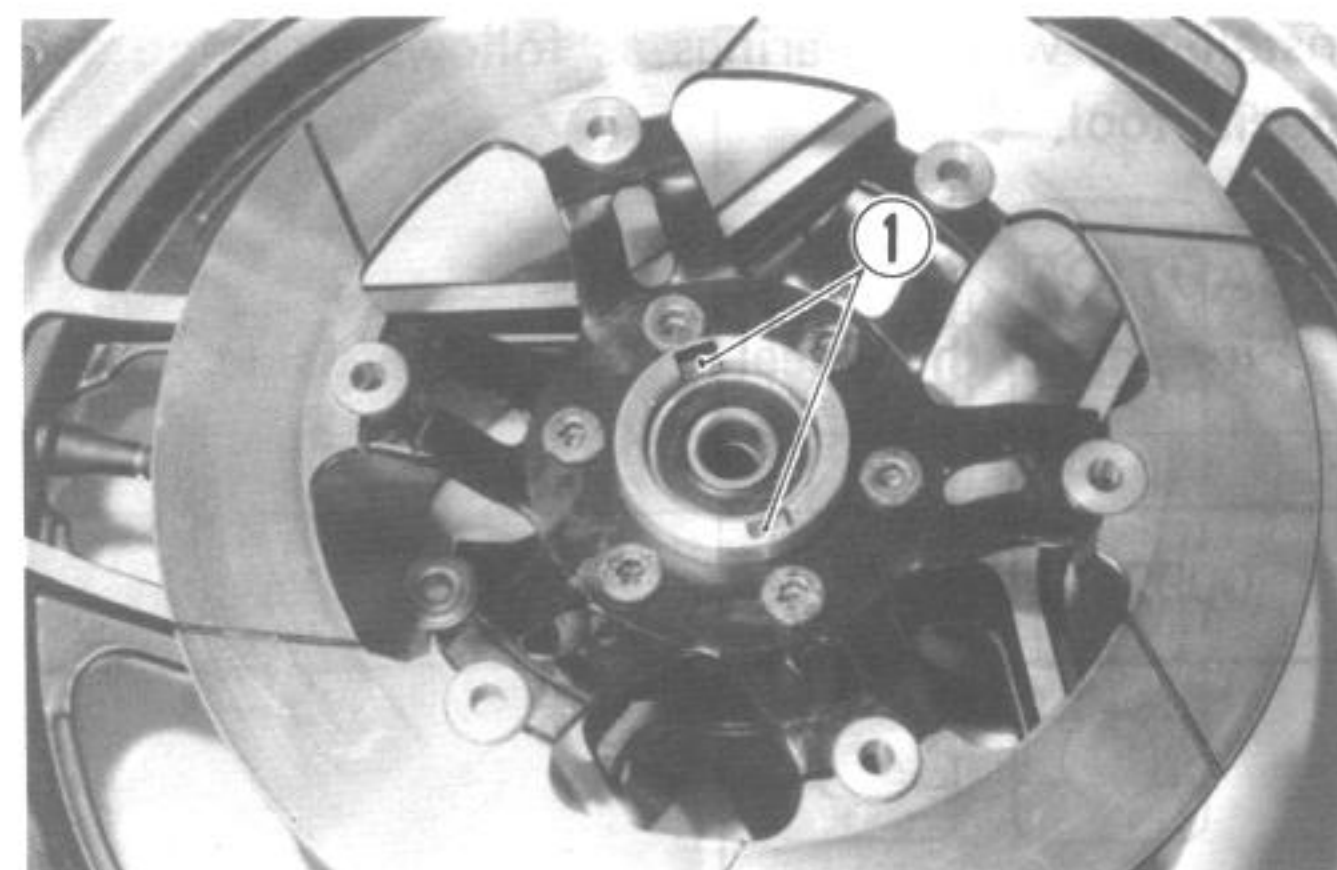
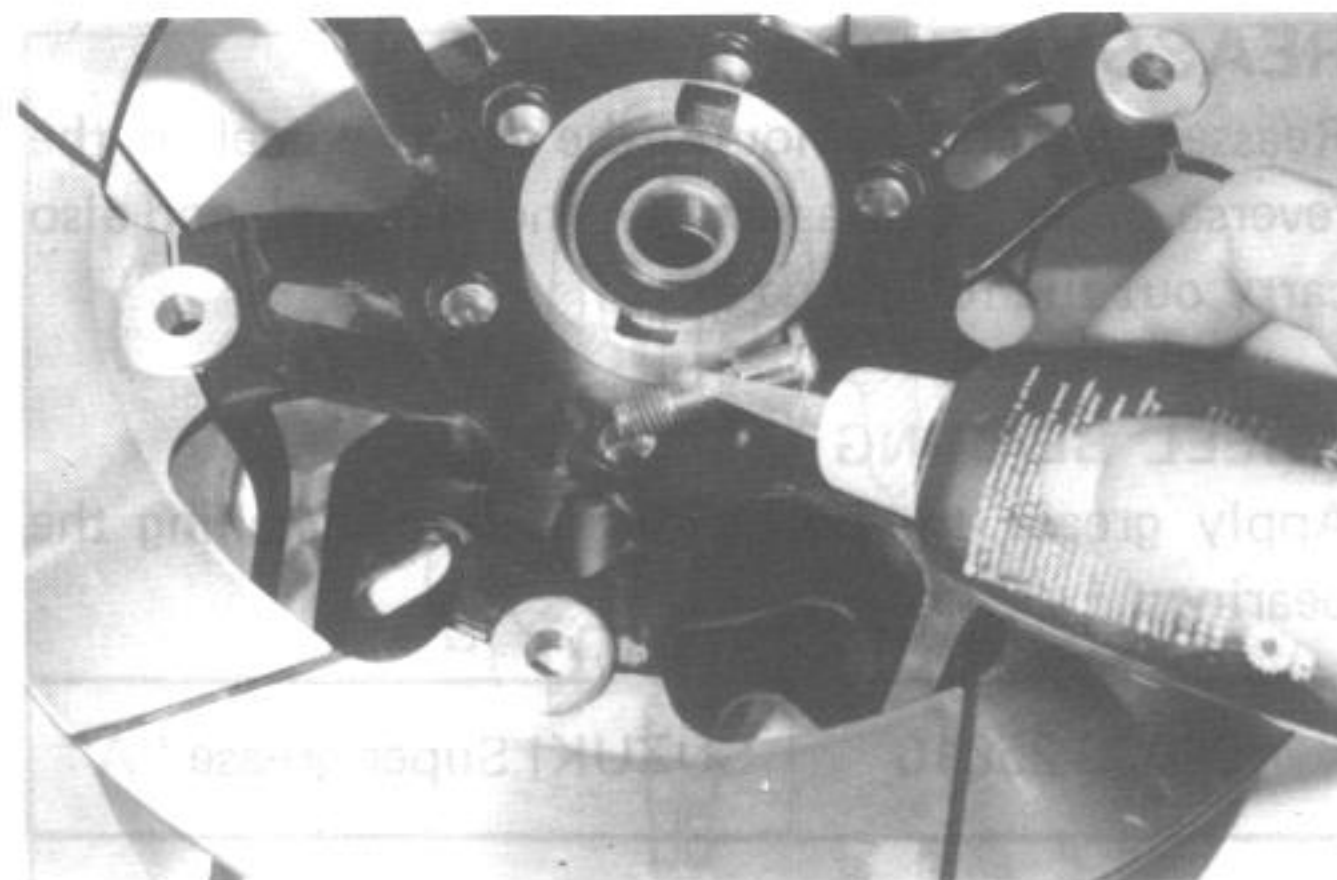

FRONT WHEEL ASSEMBLY

Remount the front wheel assembly as shown in the illustration.

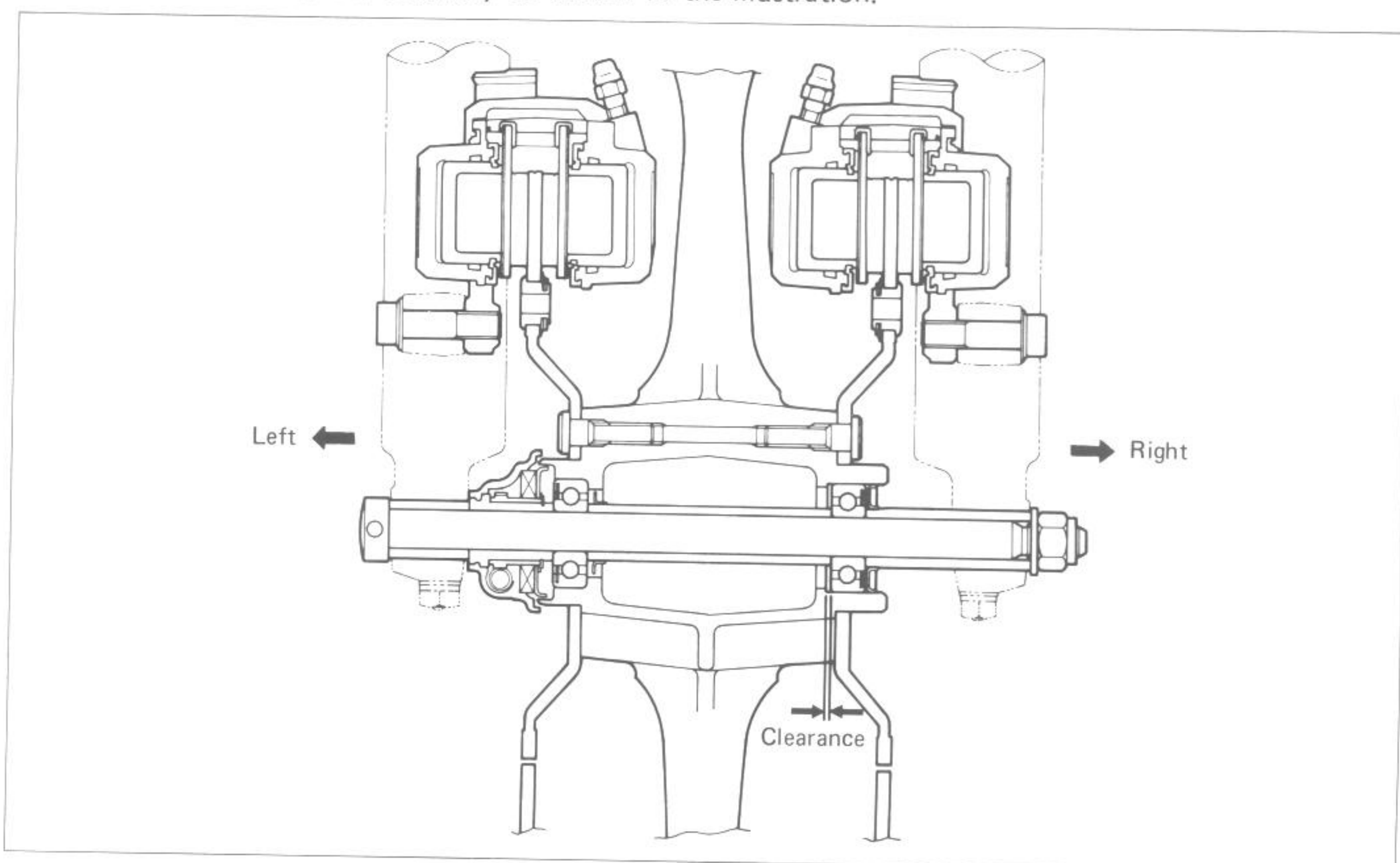

NOTE:

Push the pistons all the way into the caliper and remount the calipers.

Caliper mounting bolt tightening torque	25 – 40 N·m (2.5 – 4.0 kg-m)
---	---------------------------------

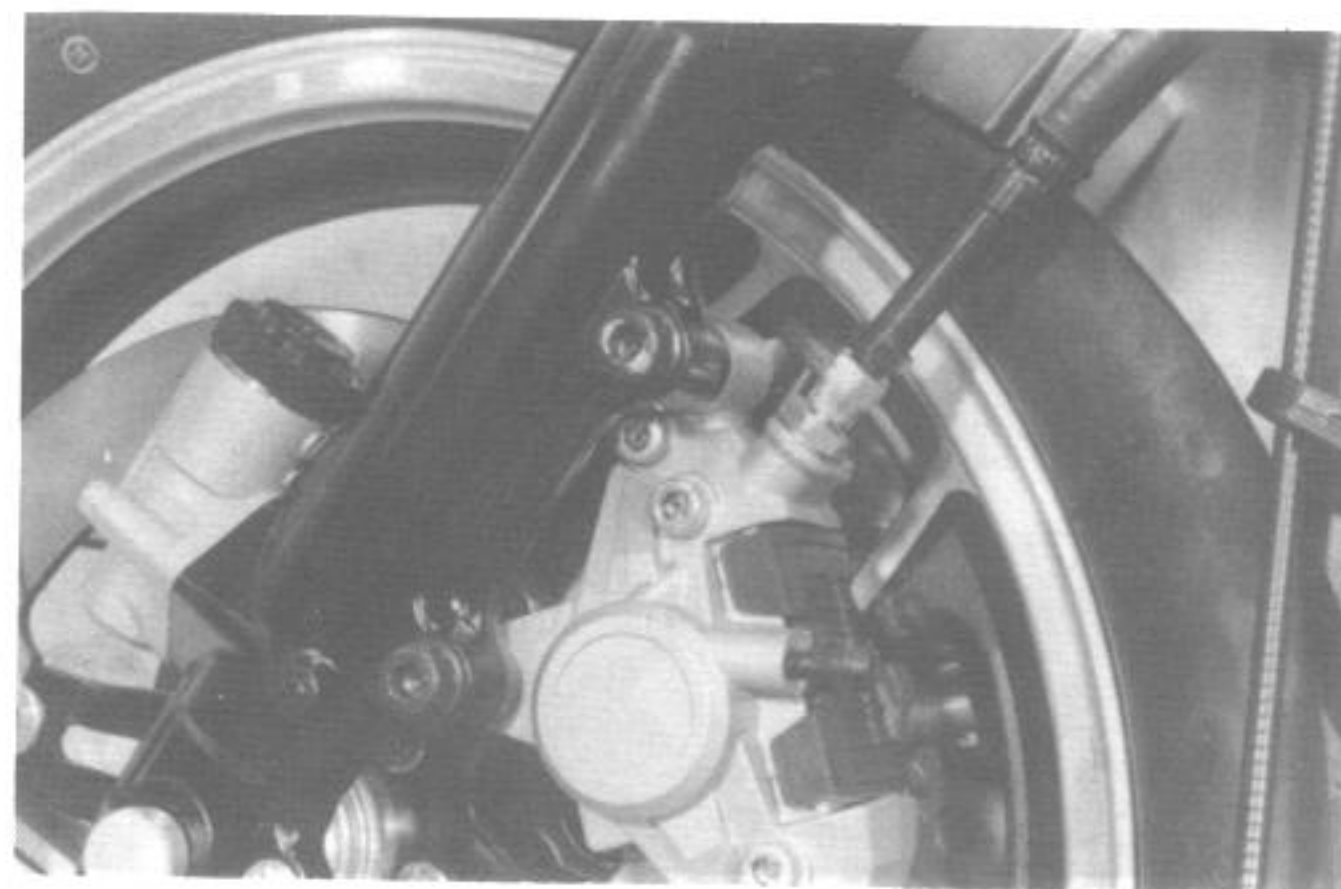

- Route the speedometer cable properly as shown in the figure.

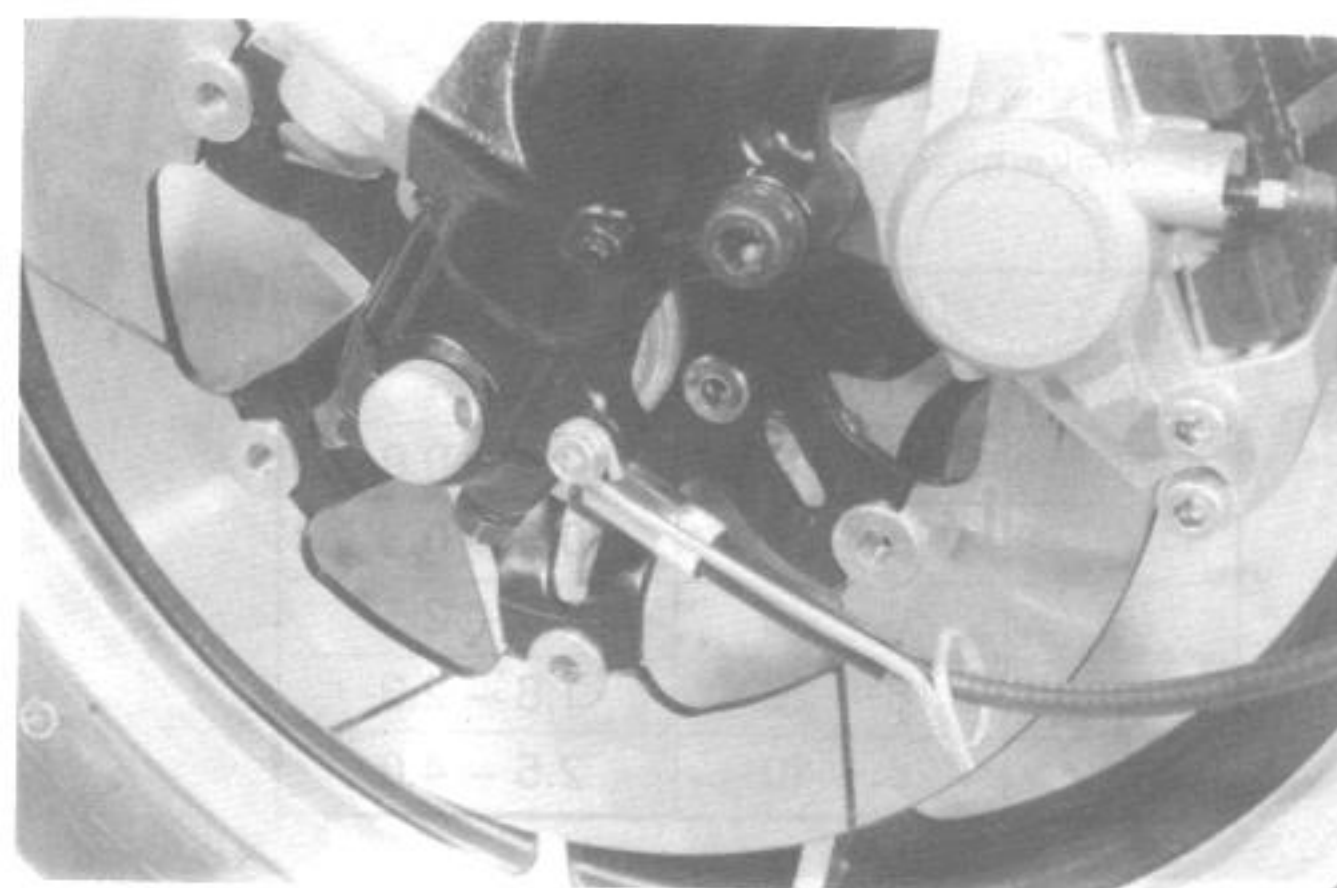

FRONT BRAKE

CONSTRUCTION (MASTER CYLINDER AND CALIPER)

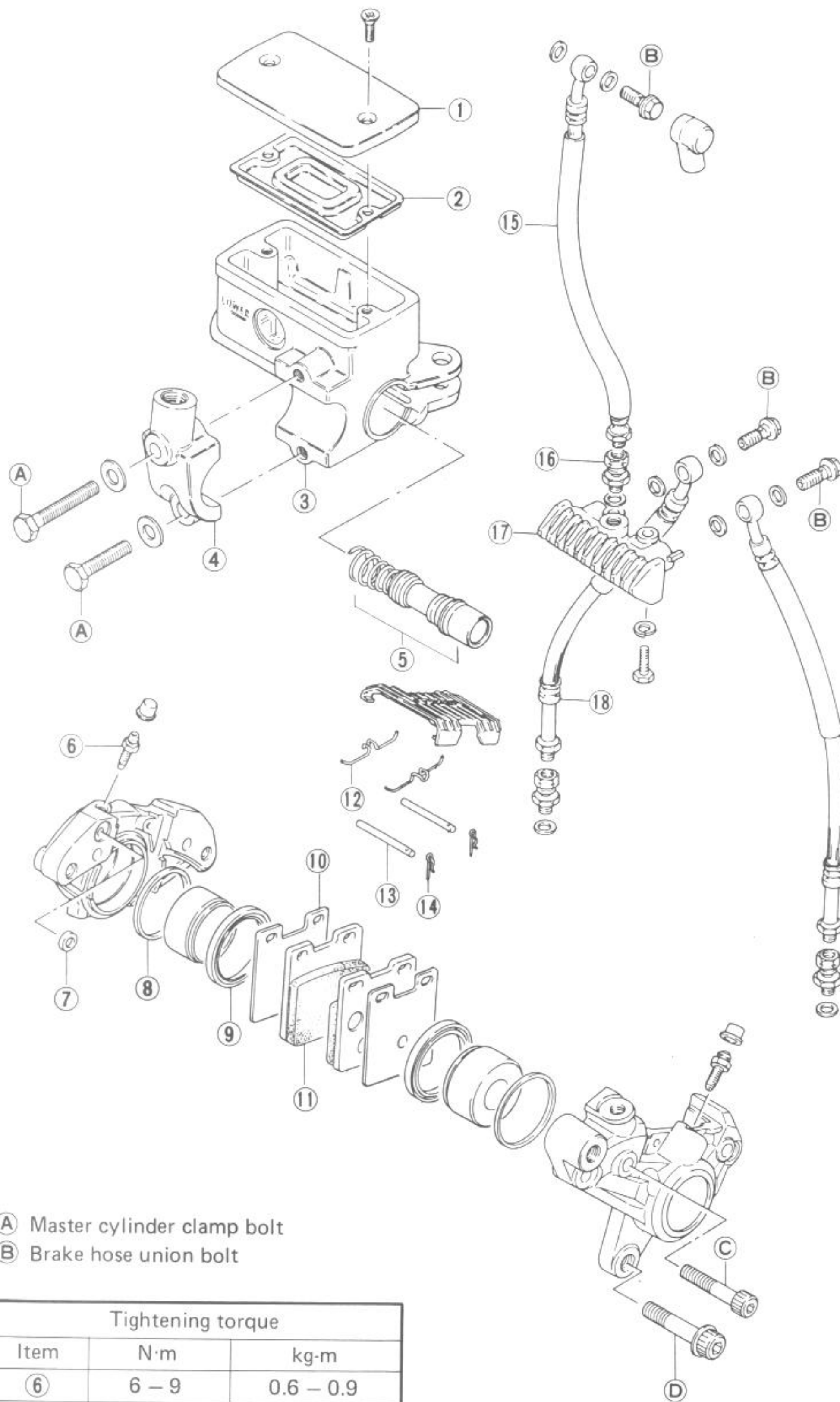

- ① Reservoir cap
- ② Diaphragm
- ③ Reservoir
- ④ Holder
- ⑤ Cup set
- ⑥ Air bleeder
- ⑦ Oil seal
- ⑧ Piston seal
- ⑨ Dust seal
- ⑩ Pad shim
- ⑪ Pad
- ⑫ Spring
- ⑬ Pin
- ⑭ Clip
- ⑮ Brake hose
- ⑯ Connector joint
- ⑰ Connector
- ⑱ Brake hose

- (A) Master cylinder clamp bolt
- (B) Brake hose union bolt

Tightening torque		
Item	N·m	kg·m
⑥	6 - 9	0.6 - 0.9
(A)	5 - 8	0.5 - 0.8
(B)	20 - 25	2.0 - 2.5
(C)	18 - 23	1.8 - 2.3
(D)	25 - 40	2.5 - 4.0

BRAKE PAD REPLACEMENT

- Remove dust cover.
- Remove clips ① and springs ②, and draw out the pins ③.

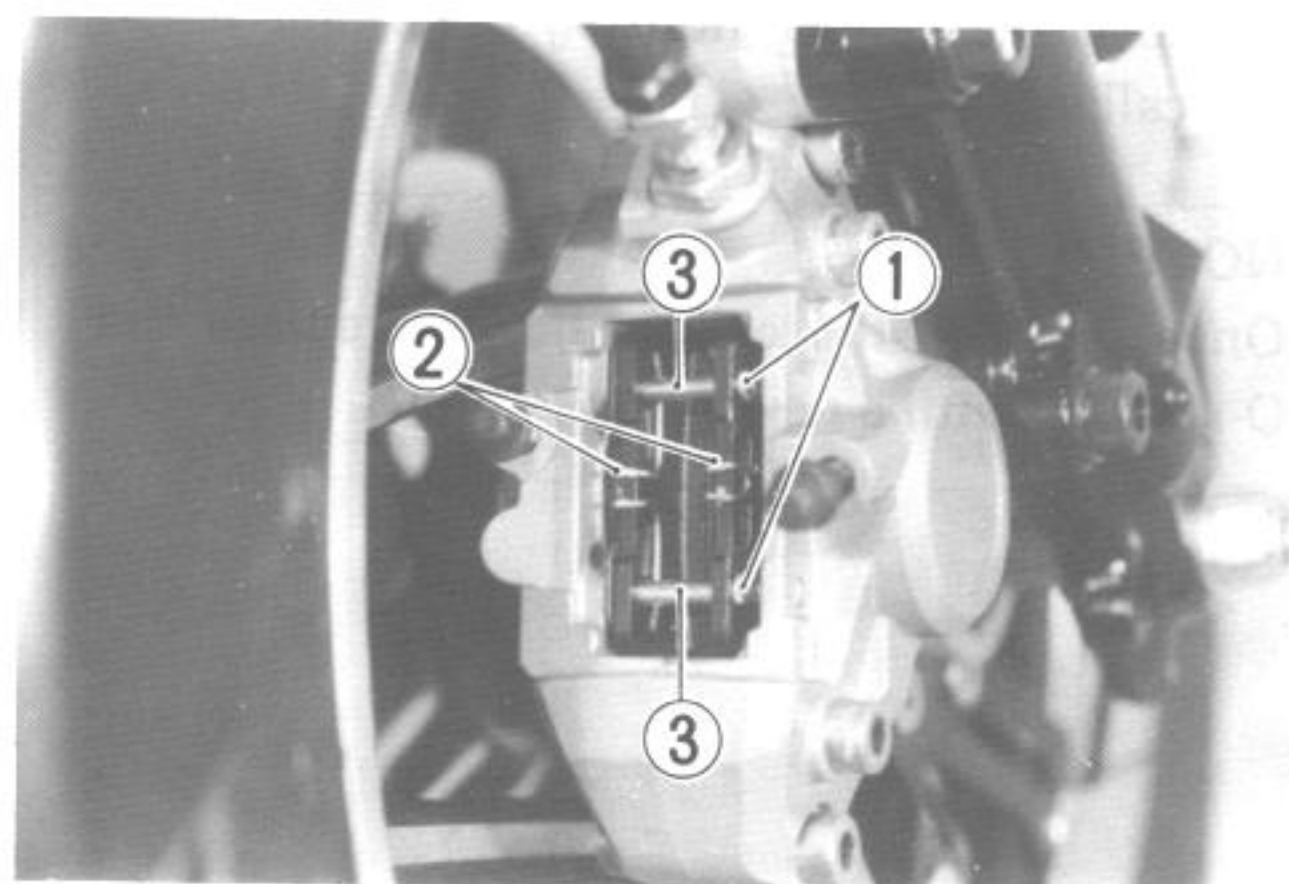

- Draw out brake pads ④ with pad shims ⑤.

CAUTION:

Replace the brake pads as a set, otherwise braking performance will be adversely affected.

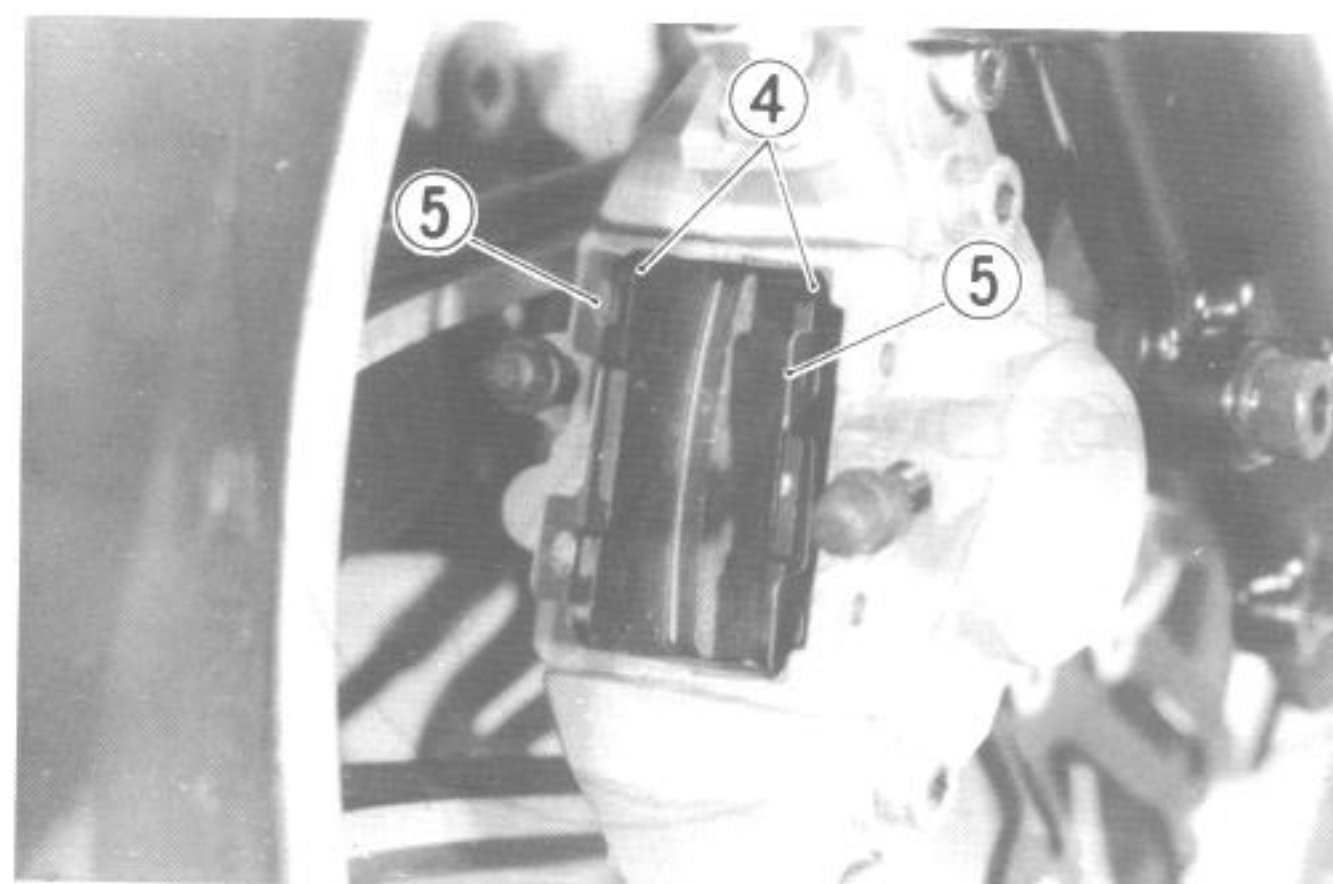

CALIPER REMOVAL AND DISASSEMBLY

- Remove the caliper from the front fork.
- Loosen the nut ② while holding the lock nut ①.
- Disconnect brake hose and catch the brake fluid in a suitable receptacle.

CAUTION:

Never re-use the brake fluid left over from the last servicing and stored for long periods.

WARNING:

Brake fluid, if it leaks, will interfere with safe running and discolor painted surfaces. Check the brake hose for cracks and hose joint for leakage before riding.

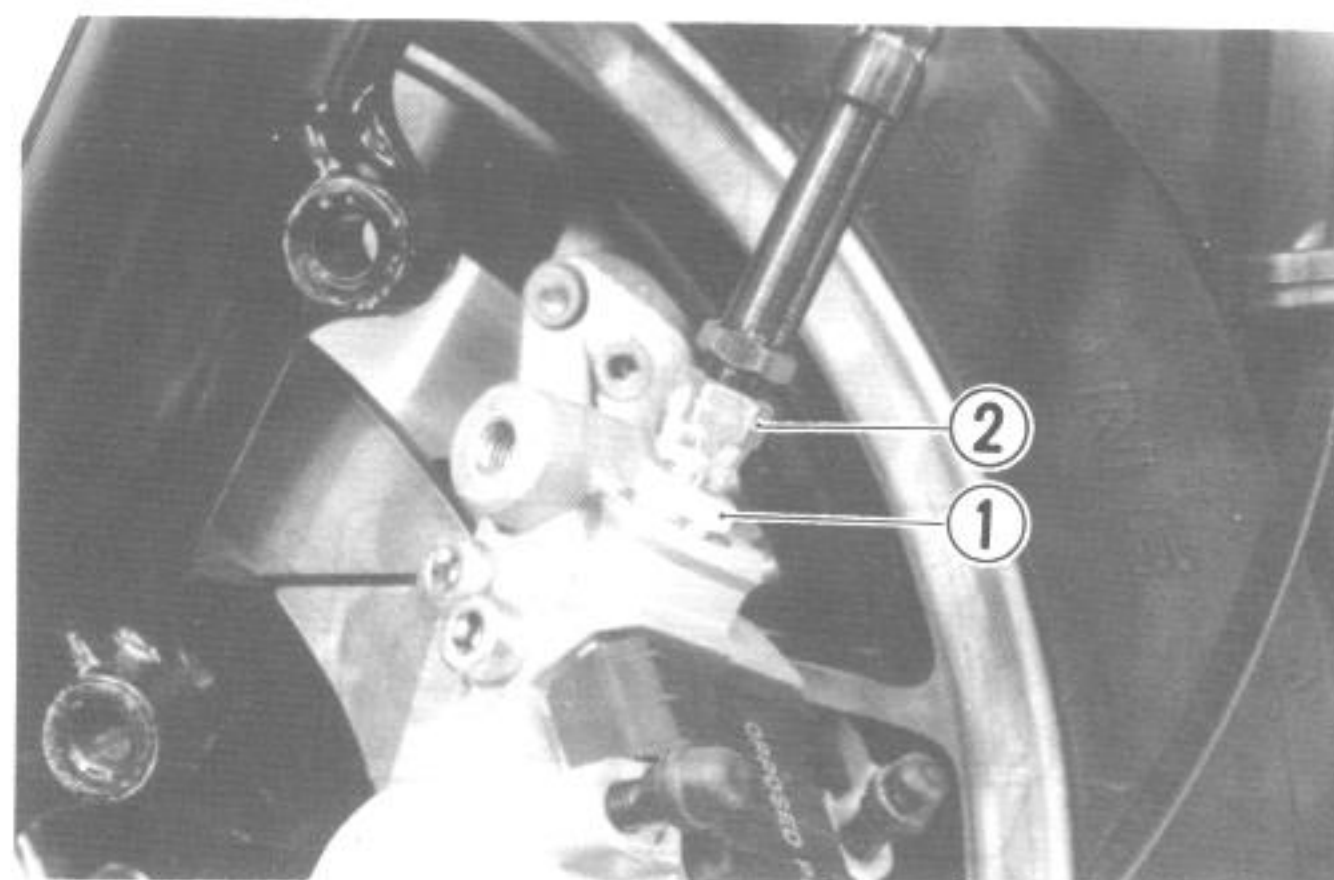
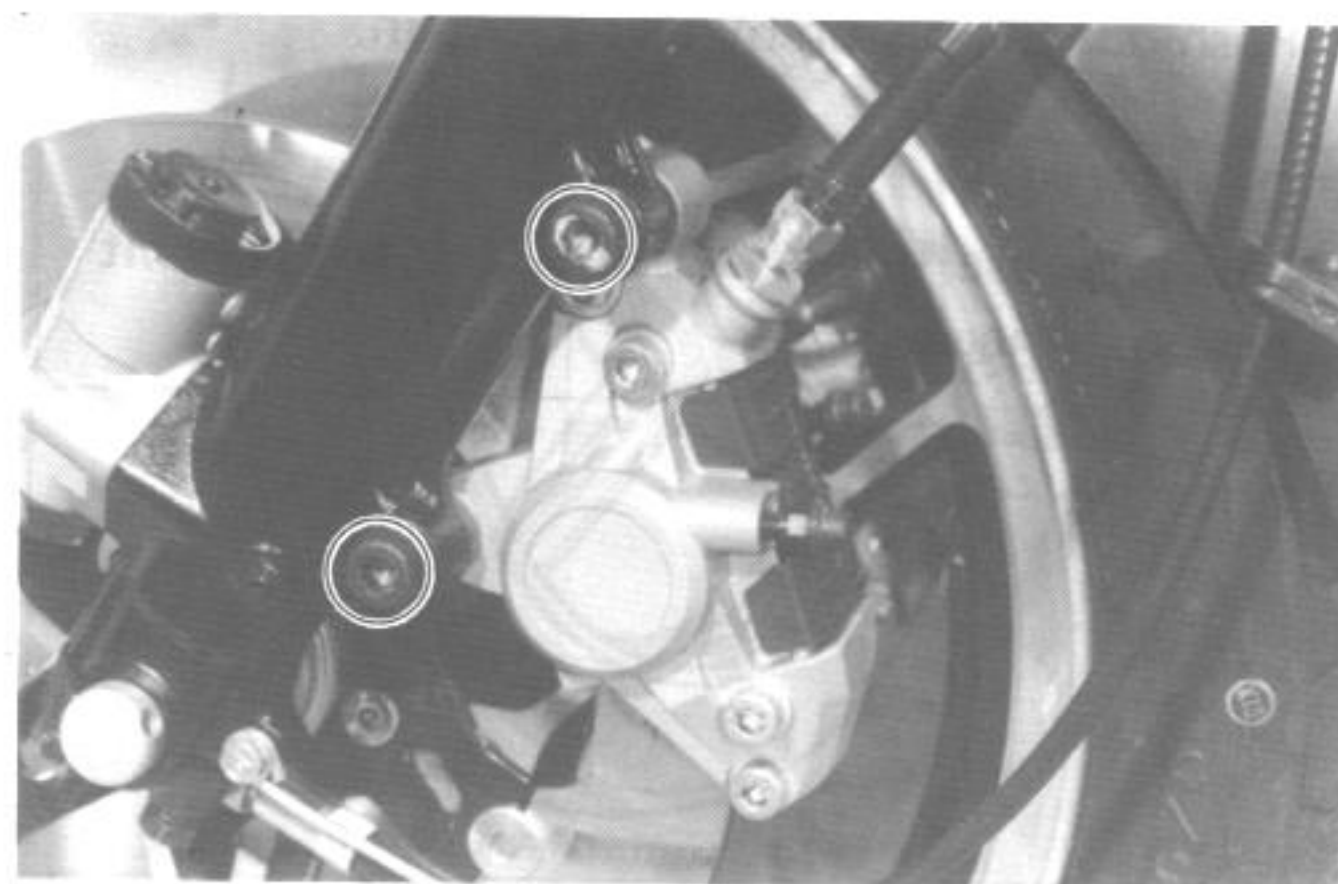

- Remove the caliper housing bolts and separate the caliper halves.

NOTE:

Once separate the caliper halves, replace the O-ring ① with a new one.

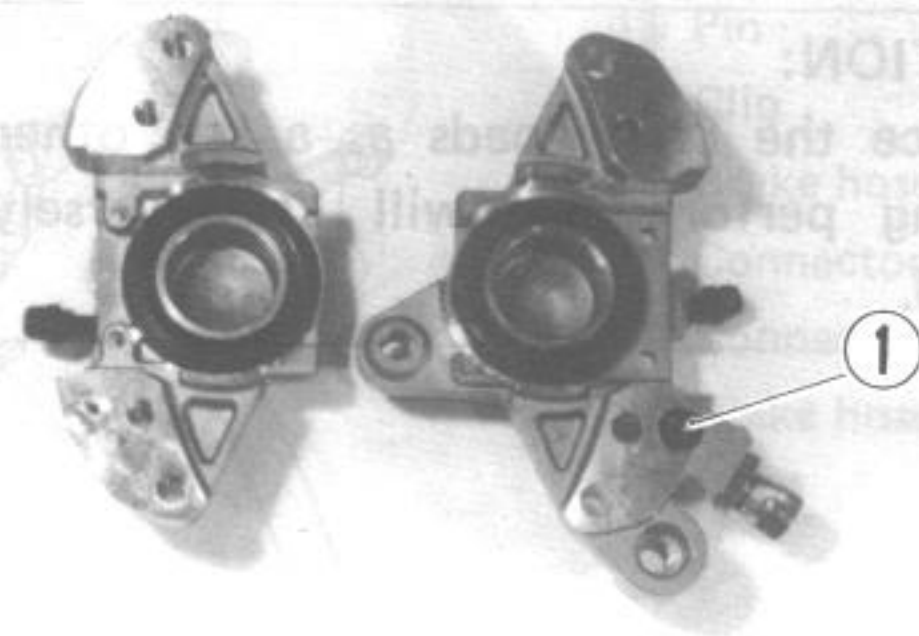
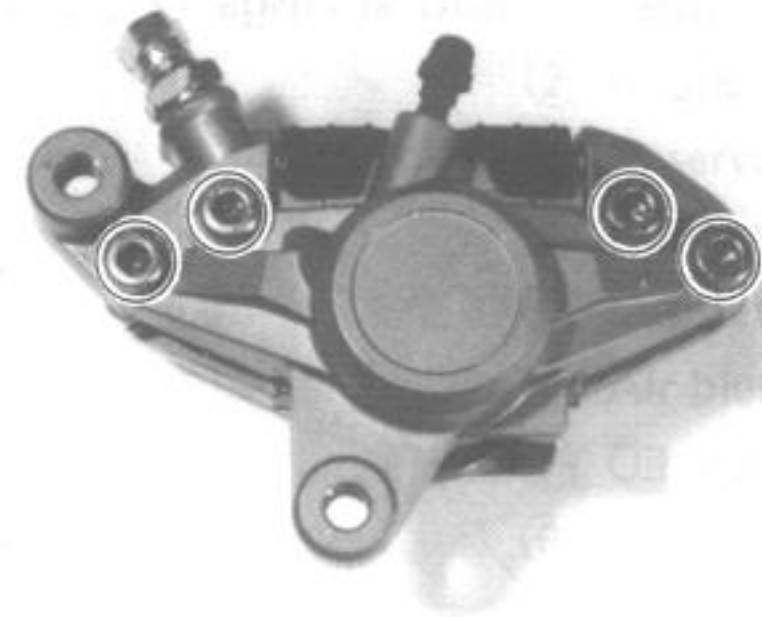

- Push out the piston by using air gun.

CAUTION:

Do not use high pressure air to prevent piston damage.



- Remove the dust boots ①, pistons ②, and O-ring ③ from the caliper housing.

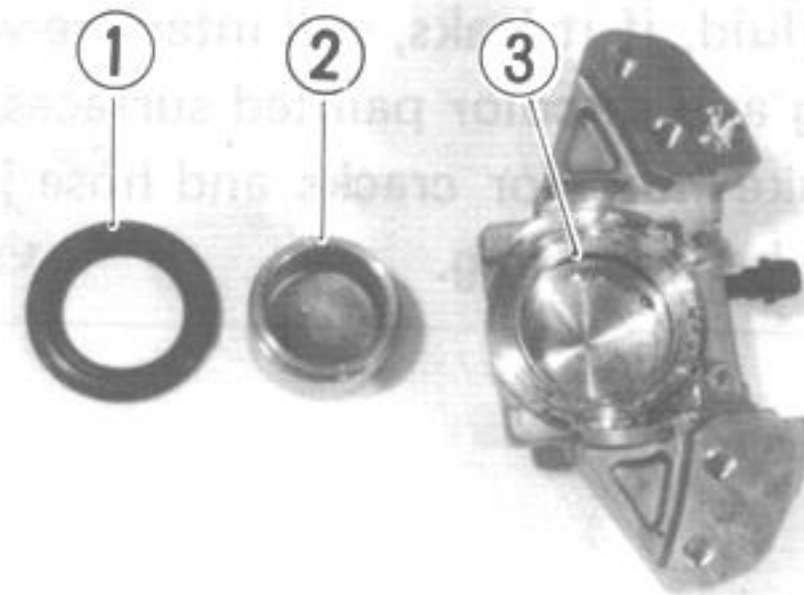

CALIPER AND DISC INSPECTION

- Inspect the caliper bore wall for nicks, scratches or other damage.
- Inspect the each rubber parts for damage and wear.
- Inspect the piston surface for any scratches or other damage.

- Using a micrometer check the disc for wear. Its thickness can be checked with disc and wheel in place. The service limit for the thickness of the discs are shown below.

09900-20205	Micrometer (0 – 25 mm)
-------------	------------------------

Front disc plate Service Limit	4.5 mm
Rear disc plate Service Limit	6.0 mm

- With the disc mounted on the wheel, check the disc for face runout with a dial gauge, as shown.

09900-20606	Dial gauge (1/100 mm)
09900-20701	Magnetic stand

Service Limit	0.30 mm
---------------	---------

CALIPER REASSEMBLY

Reassemble the caliper in the reverse orders of disassembly and by taking the following steps:

CAUTION:

Wash the caliper components with fresh brake fluid before reassembly.

Never use cleaning solvent or gasoline to wash them.

Apply brake fluid to the caliper bore and piston to be inserted into the bore.

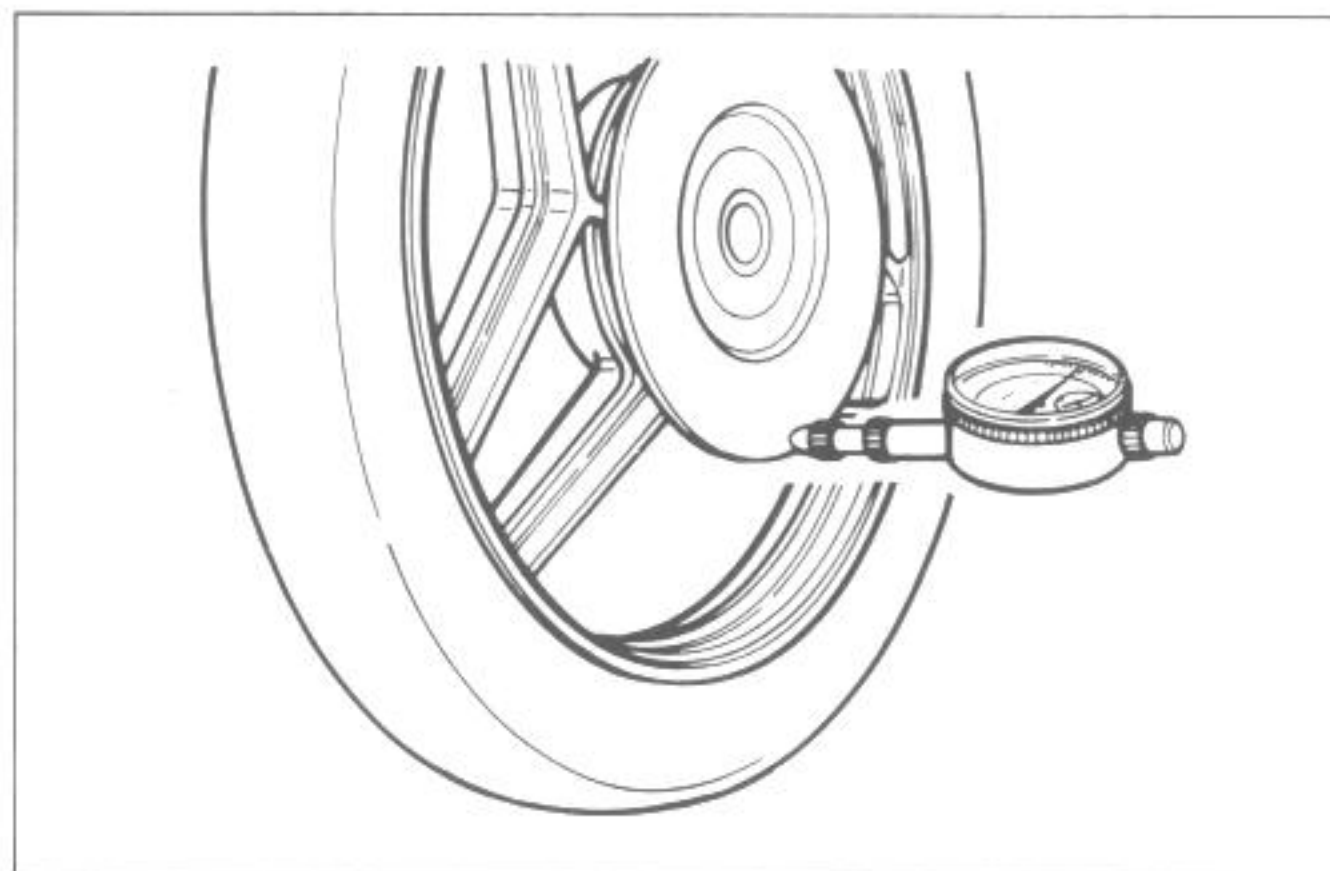
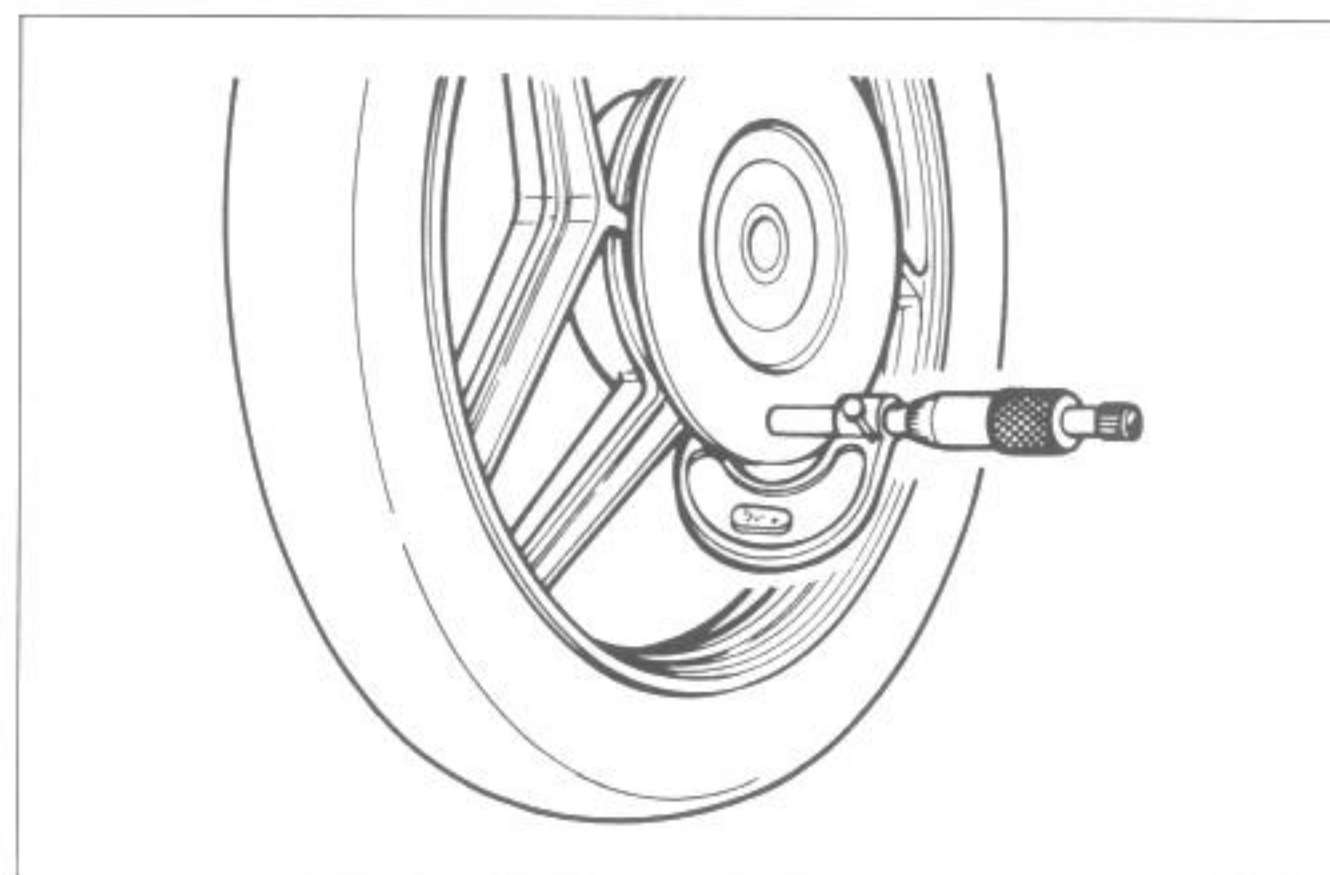
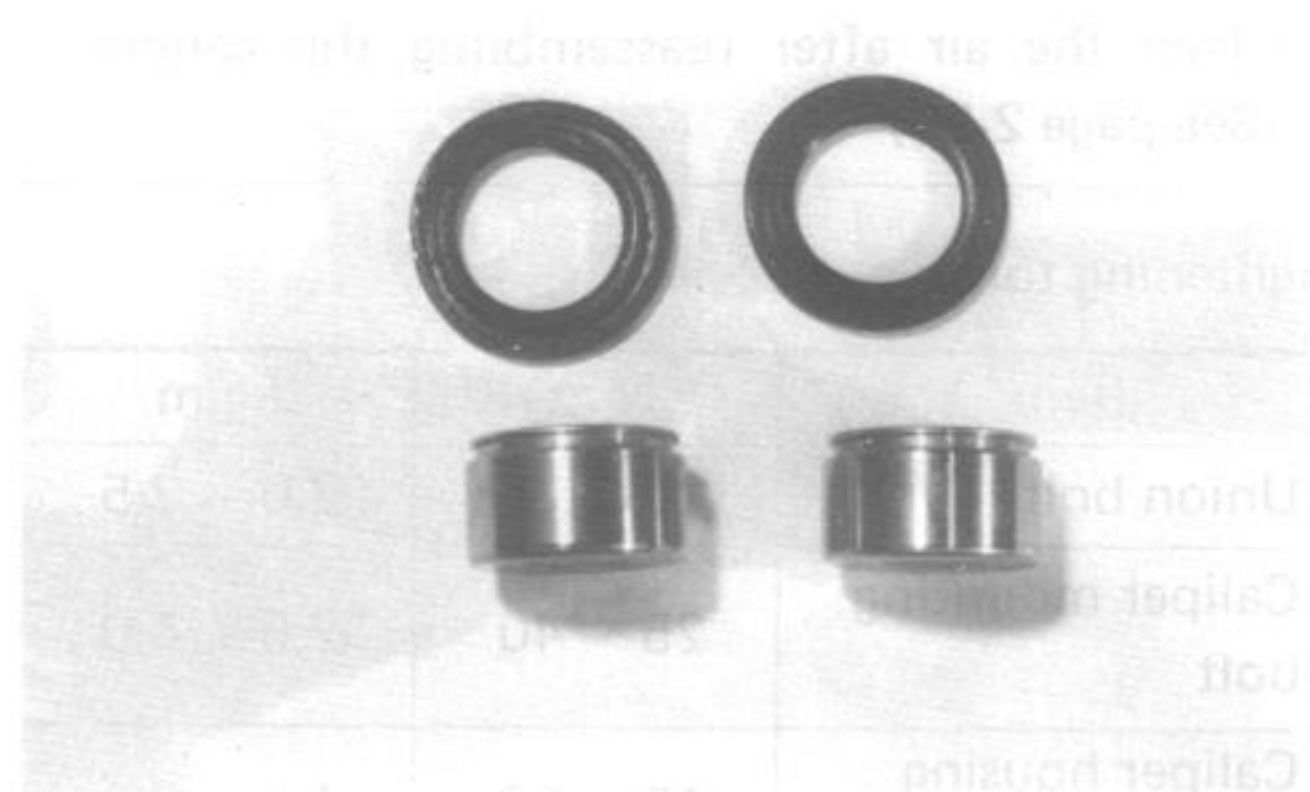

WARNING:

Bleed the air after reassembling the caliper
(See page 2-20)

Tightening torque

Item	N·m	kg-m
Union bolt	20 – 25	2.0 – 2.5
Caliper mounting bolt	25 – 40	2.5 – 4.0
Caliper housing bolt	18 – 23	1.8 – 2.3

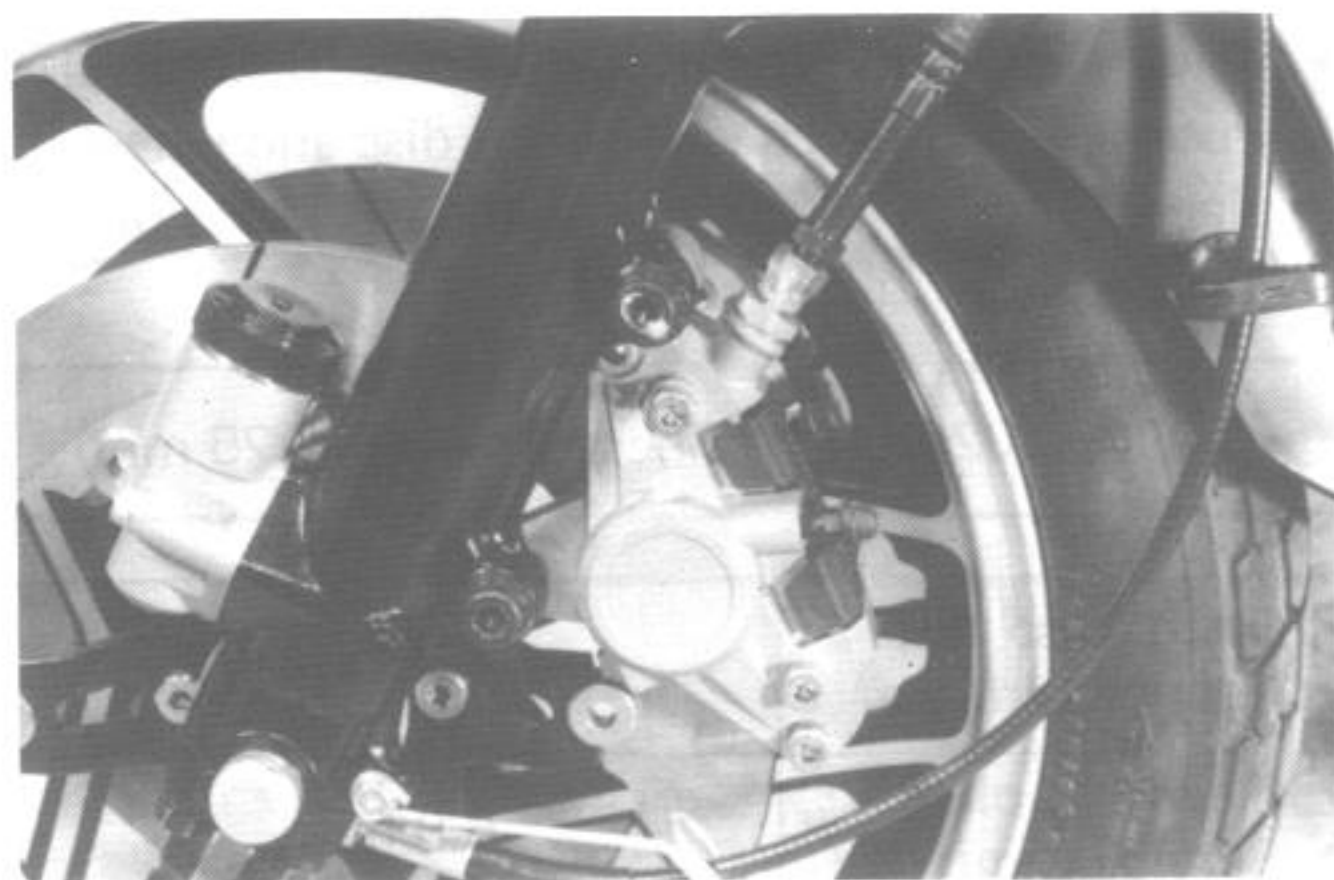
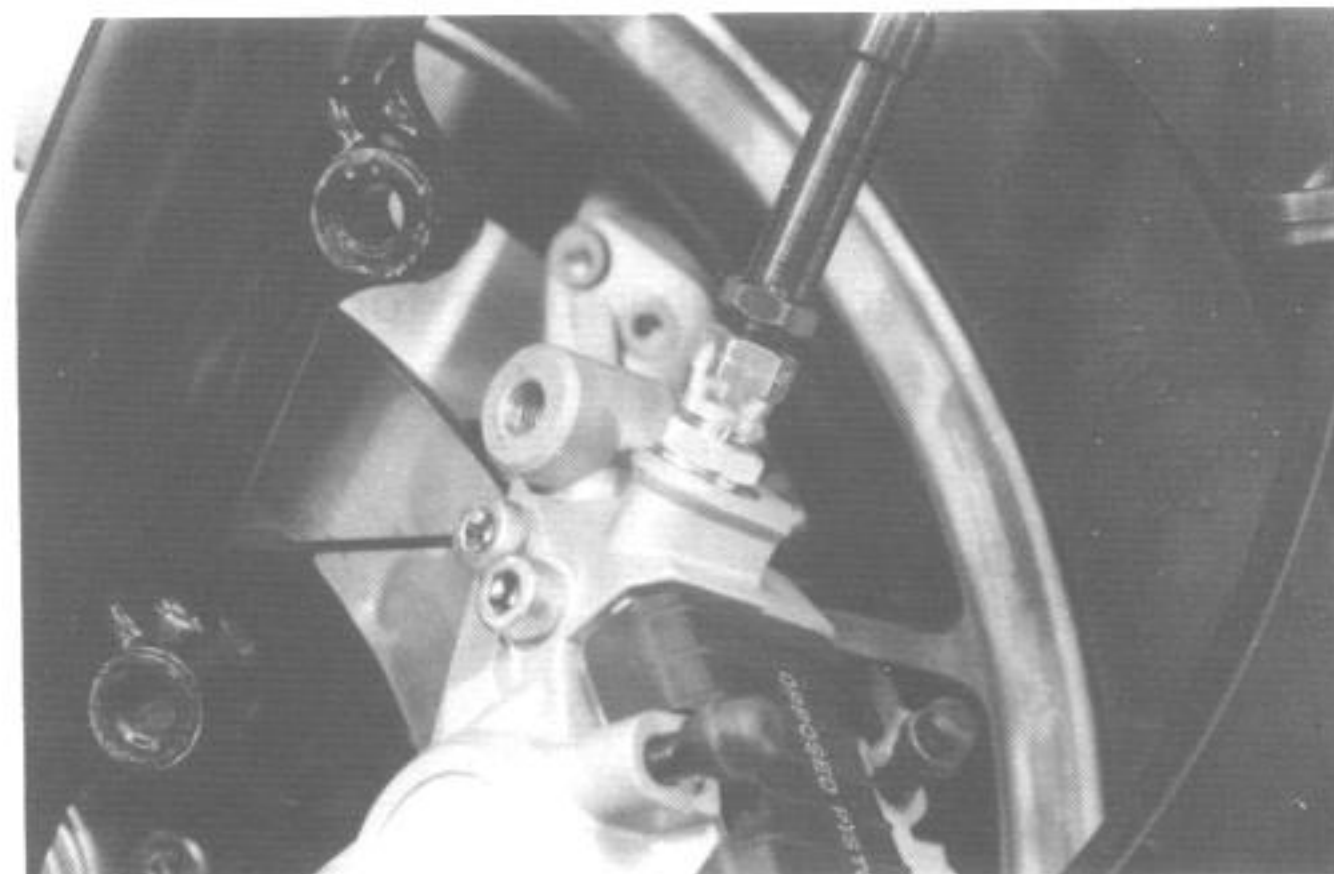
**MASTER CYLINDER REMOVAL AND DISASSEMBLY**

- Take off front brake light switch.
- Place a cloth underneath the union bolt on the master cylinder to catch spilled drops of brake fluid. Unscrew the union bolt and disconnect the brake hose/master cylinder joint.

CAUTION:

Completely wipe off any brake fluid adhering to any part of motorcycle. The fluid reacts chemically with paint, plastics, rubber materials, etc.



- Remove the two clamp bolts and take off master cylinder assembly.

Master cylinder clamp bolt tightening torque	6 – 9 N·m (0.6 – 0.9 kg-m)
--	-------------------------------

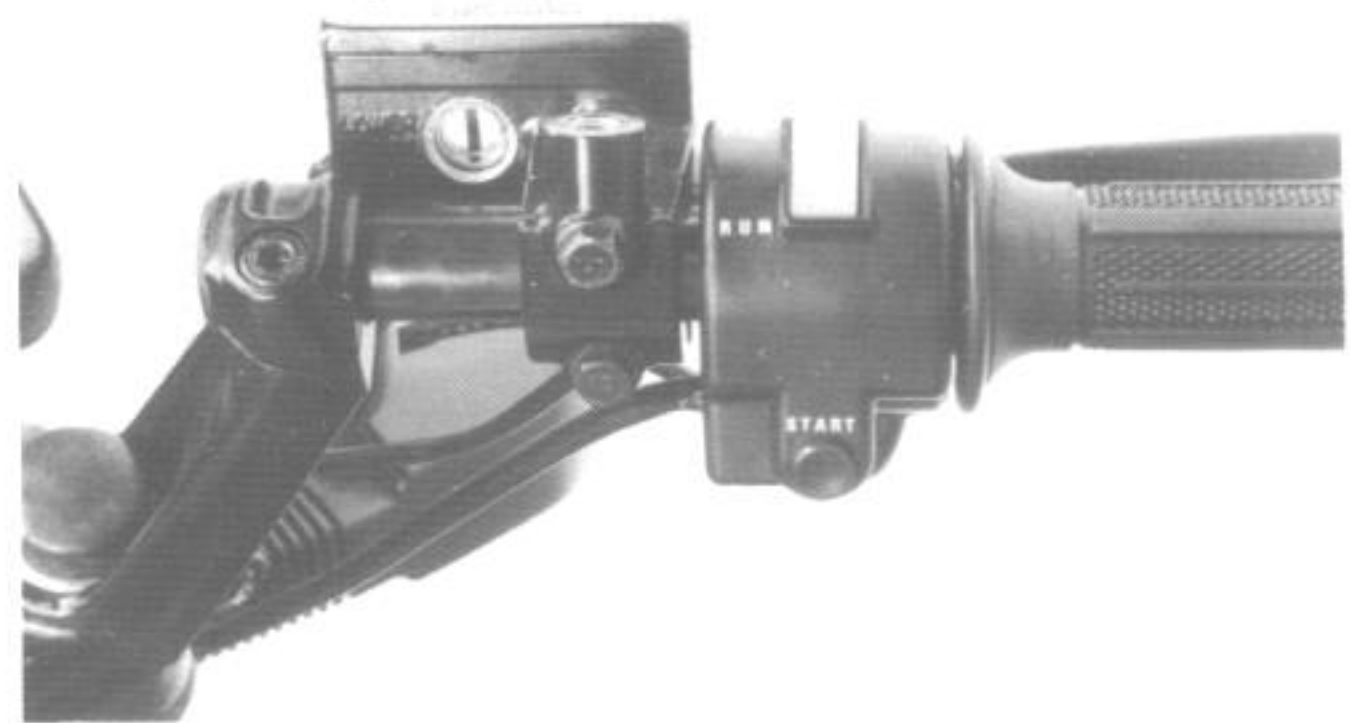

- Remove the front brake lever.
- Remove reservoir cap and diaphragm.
- Drain brake fluid.

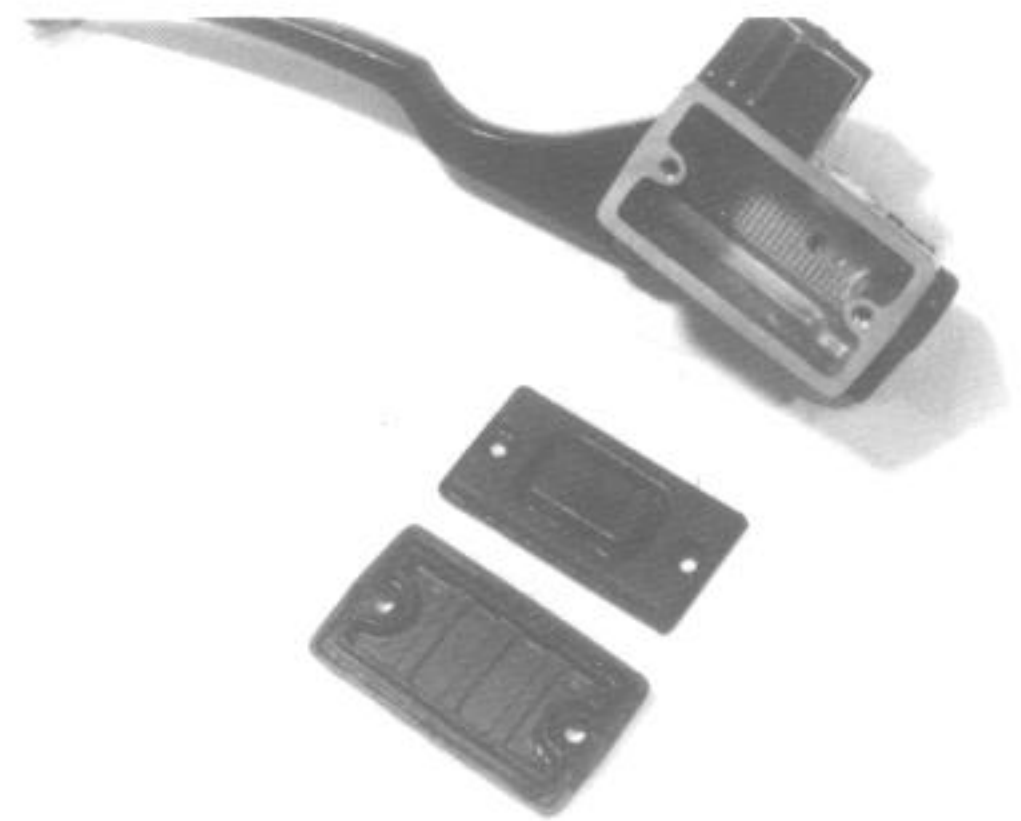

- Pull off dust boot.
- Remove circlip by using the special tool.
- Remove piston, primary cup and spring.

09900-06108	Snap ring pliers
-------------	------------------

- ① Circlip
- ② Piston
- ③ Primary cup
- ④ Return spring

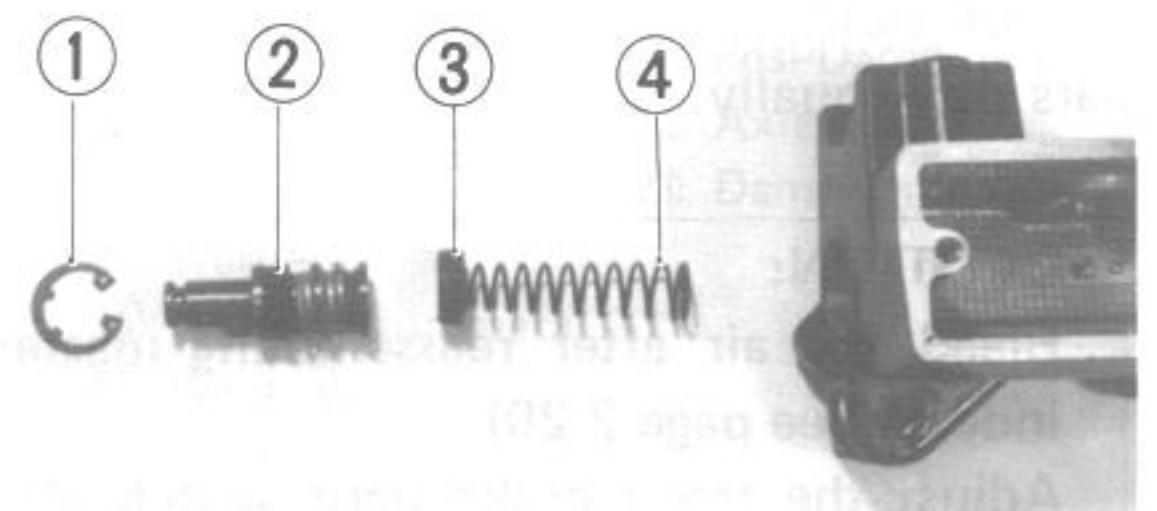
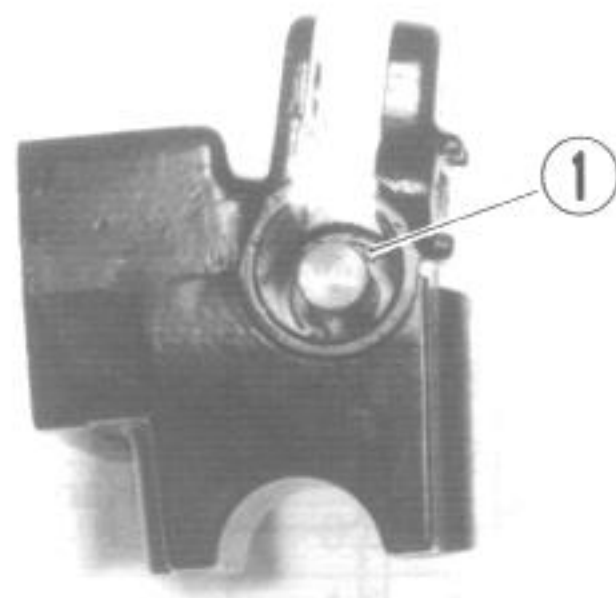
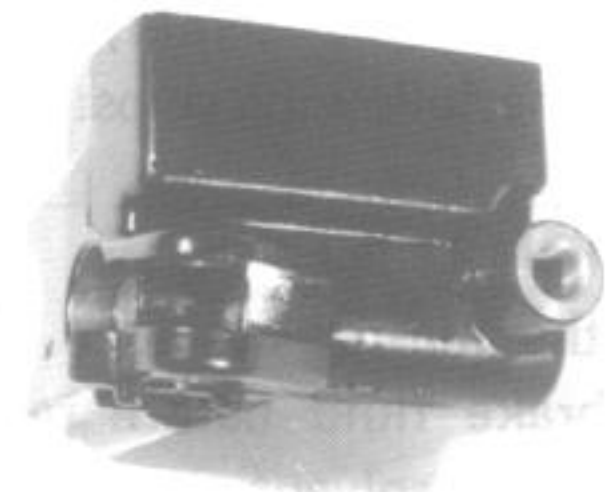

MASTER CYLINDER INSPECTION

- Inspect the master cylinder bore for any scratches or other damage.
- Inspect the piston surface for scratches or other damage.
- Inspect the primary cup and dust boot for wear or damage.

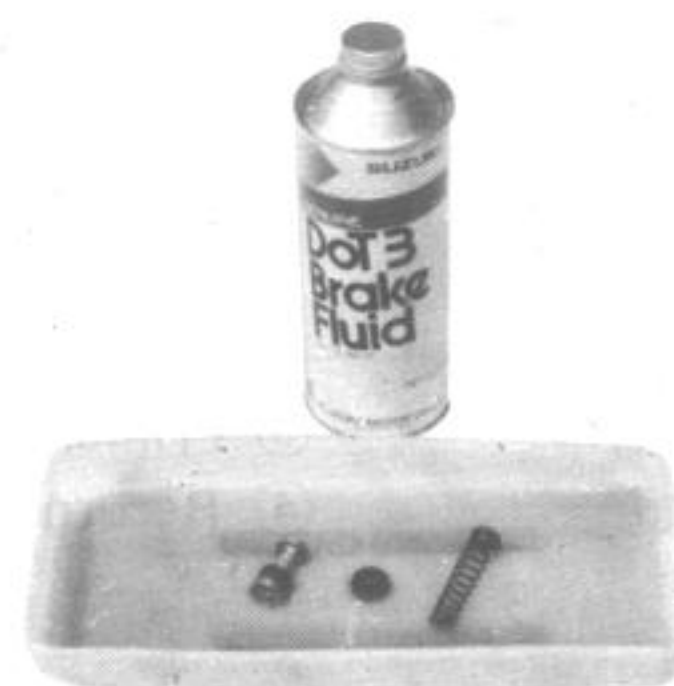
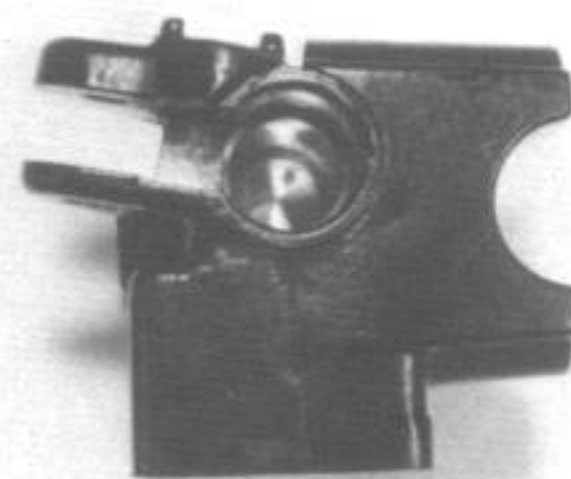
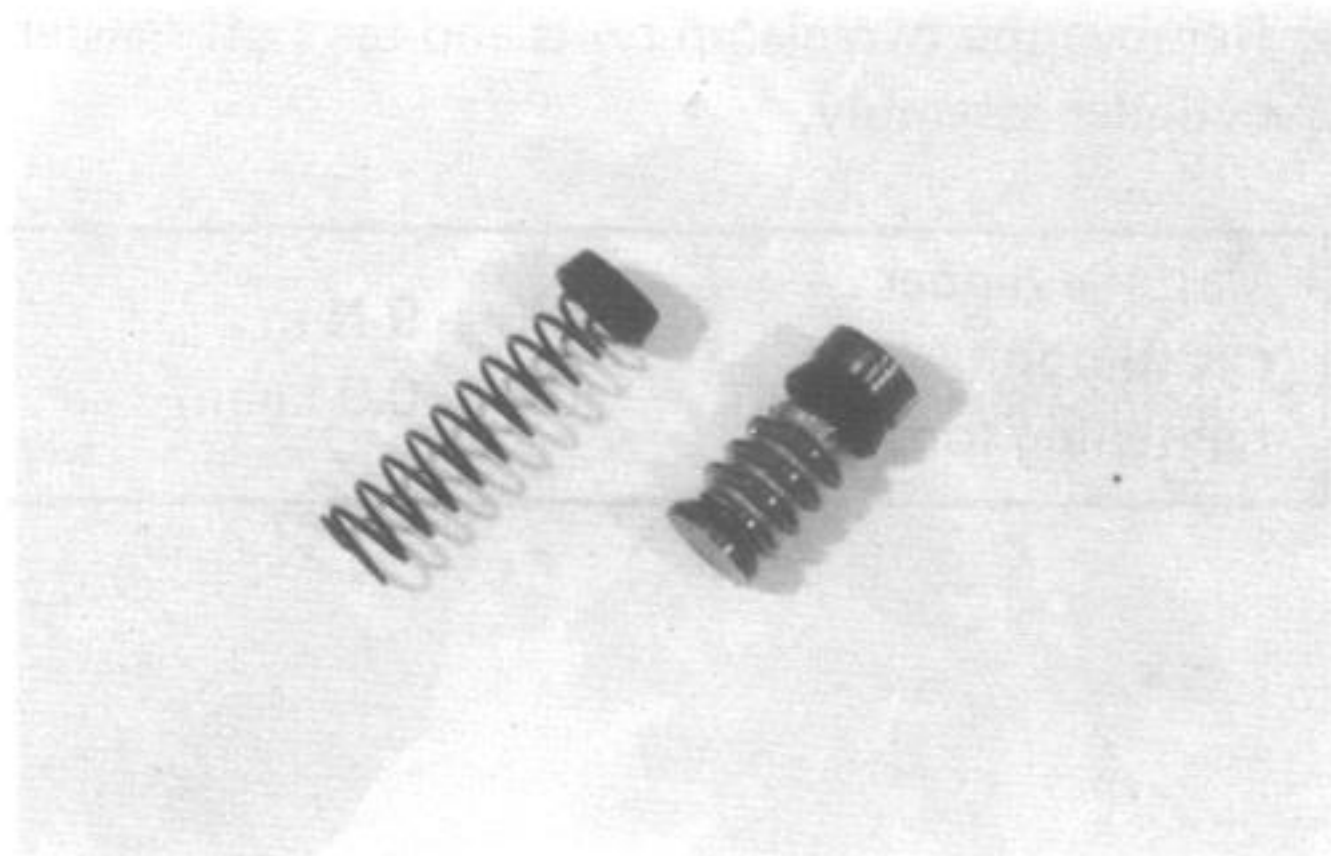

MASTER CYLINDER REASSEMBLY

Reassemble and remount the master cylinder in the reverse order of disassembly and removal, and also carry out the following steps:

CAUTION:

Wash the master cylinder components with fresh brake fluid before reassembly. Never use cleaning solvent or gasoline to wash them. Apply brake fluid to the cylinder bore and all the internals to be inserted into the bore.

When remounting the master cylinder on the handlebars, secure the clamp so that the clearances **(A)** of both upside and downside of the handlebars stay equally.

CAUTION:

Bleed the air after reassembling master cylinder. (See page 2-20).
Adjust the front brake light switch after installation.

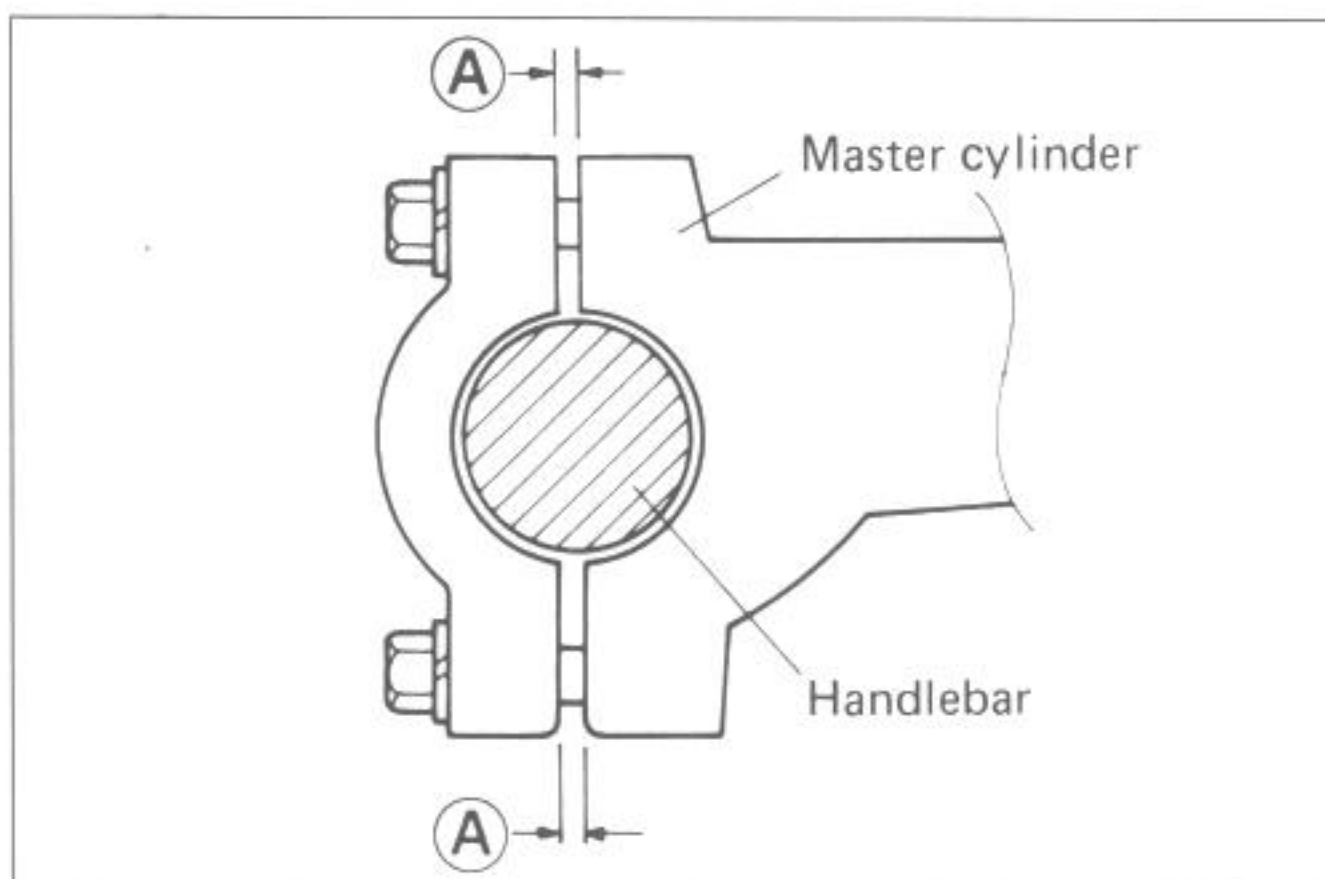

FRONT FORK

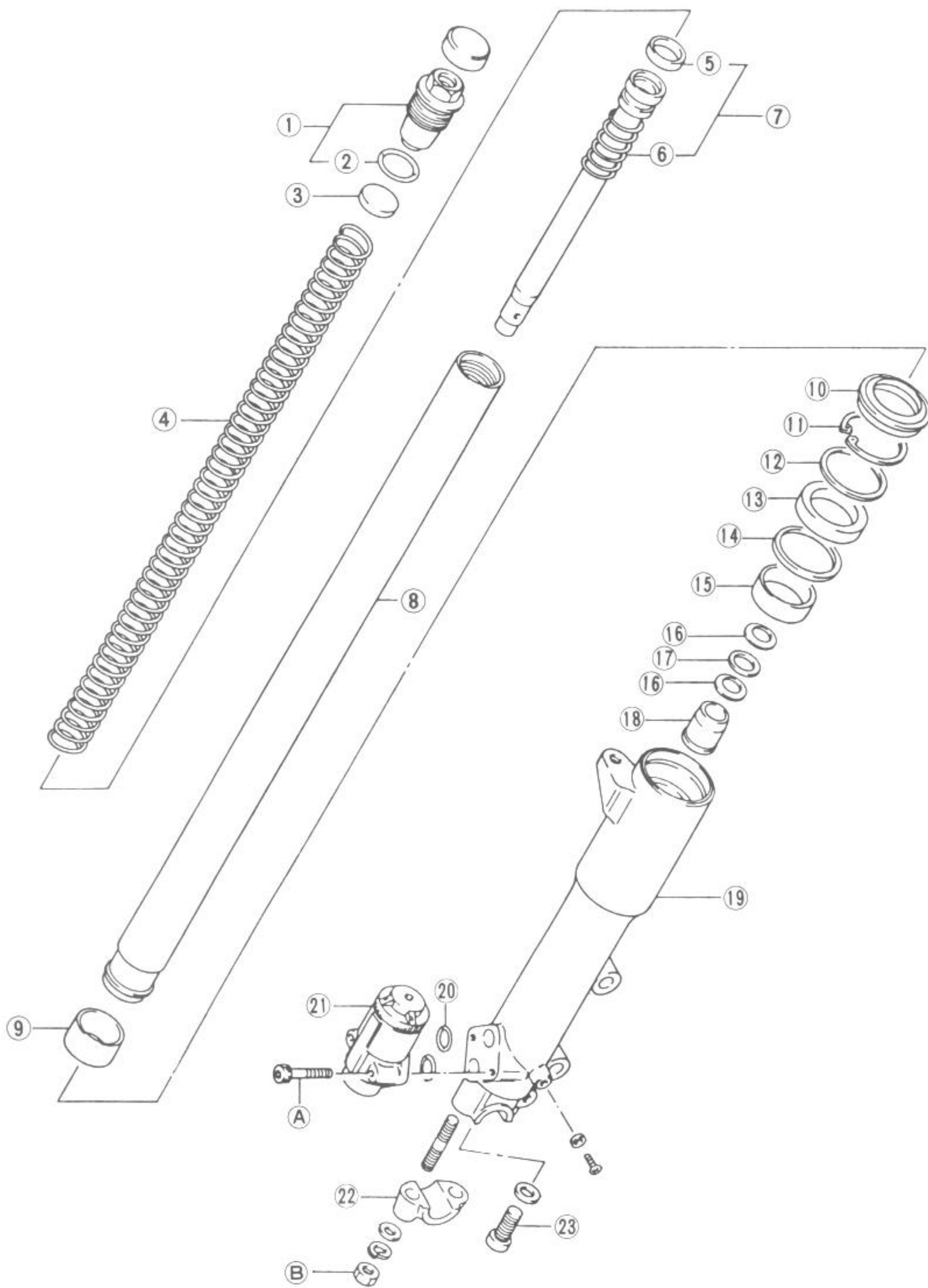

Tightening torque		
Item	N·m	kg·m
①	15 – 30	1.5 – 3.0
②③	20 – 25	2.0 – 2.5
A	6 – 8	0.6 – 0.8
B	15 – 25	1.5 – 2.5

- ① Spring adjuster & fork cap
- ② O-ring
- ③ Spring seat
- ④ Fork spring
- ⑤ Damper rod ring
- ⑥ Rebound spring
- ⑦ Damper rod set
- ⑧ Inner tube
- ⑨ Anti-friction metal
- ⑩ Dust seal
- ⑪ Snap ring
- ⑫ Washer
- ⑬ Oil seal
- ⑭ Washer
- ⑮ Anti-friction metal
- ⑯ Wave washer
- ⑰ Washer
- ⑱ Oil lock piece
- ⑲ Outer tube
- ⑳ O-ring
- ㉑ Posi-Damp unit
- ㉒ Axle holder
- ㉓ Damper rod bolt

NEW TYPE FRONT FORK

The front forks are equipped with an anti-dive system which is activated by the degree of fork stroke. The system limits fork dive through an increase of the compression damping rate.

FUNCTION

Under normal road conditions the forks move through their initial travel with the anti-dive device allowing the fork fluid to move through its metered passageway normally. When the fork is compressed abruptly to a specific point, the increase in the fluid pressure forces a spring regulated valve to close off part of the fluid flow causing a sharp rise in the damping rate.

A relief spring is used to prevent the fluid pressure from rising beyond too high a pressure which would too severely limit the fork action.

ADJUSTMENT

The rider may select from 4 different anti-dive engagement points. As the selection knob is turned in or clockwise the pressure on the valve sensing spring is higher. Under this condition the fork stroke must be greater before enough pressure is generated to clear the valve and restrict the fluid flow increasing the demping rate.

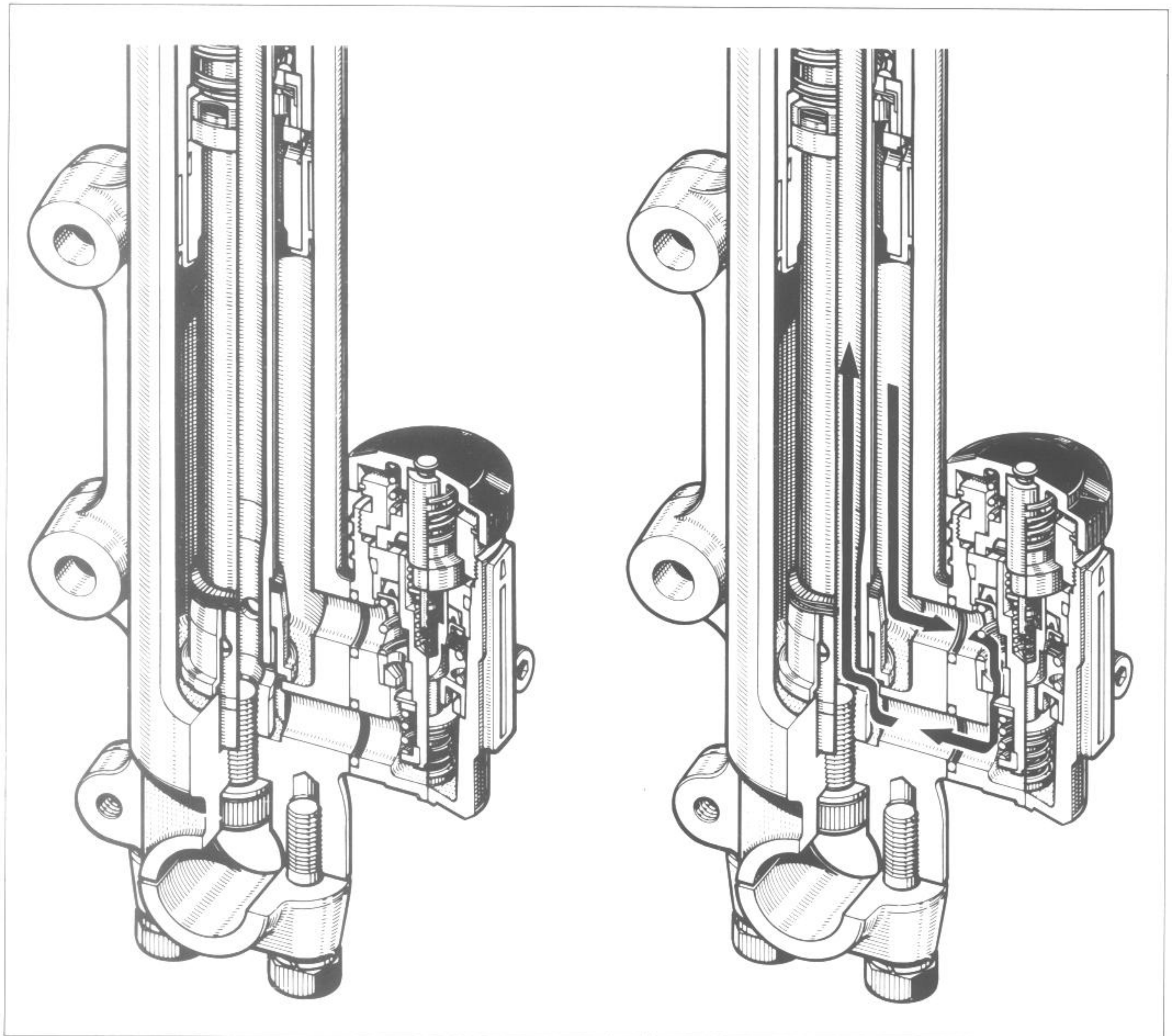

REMOVAL

- Take off the calipers and disconnect speedometer cable.
- Remove the front wheel (See page 6-2).
- Remove the front fender.

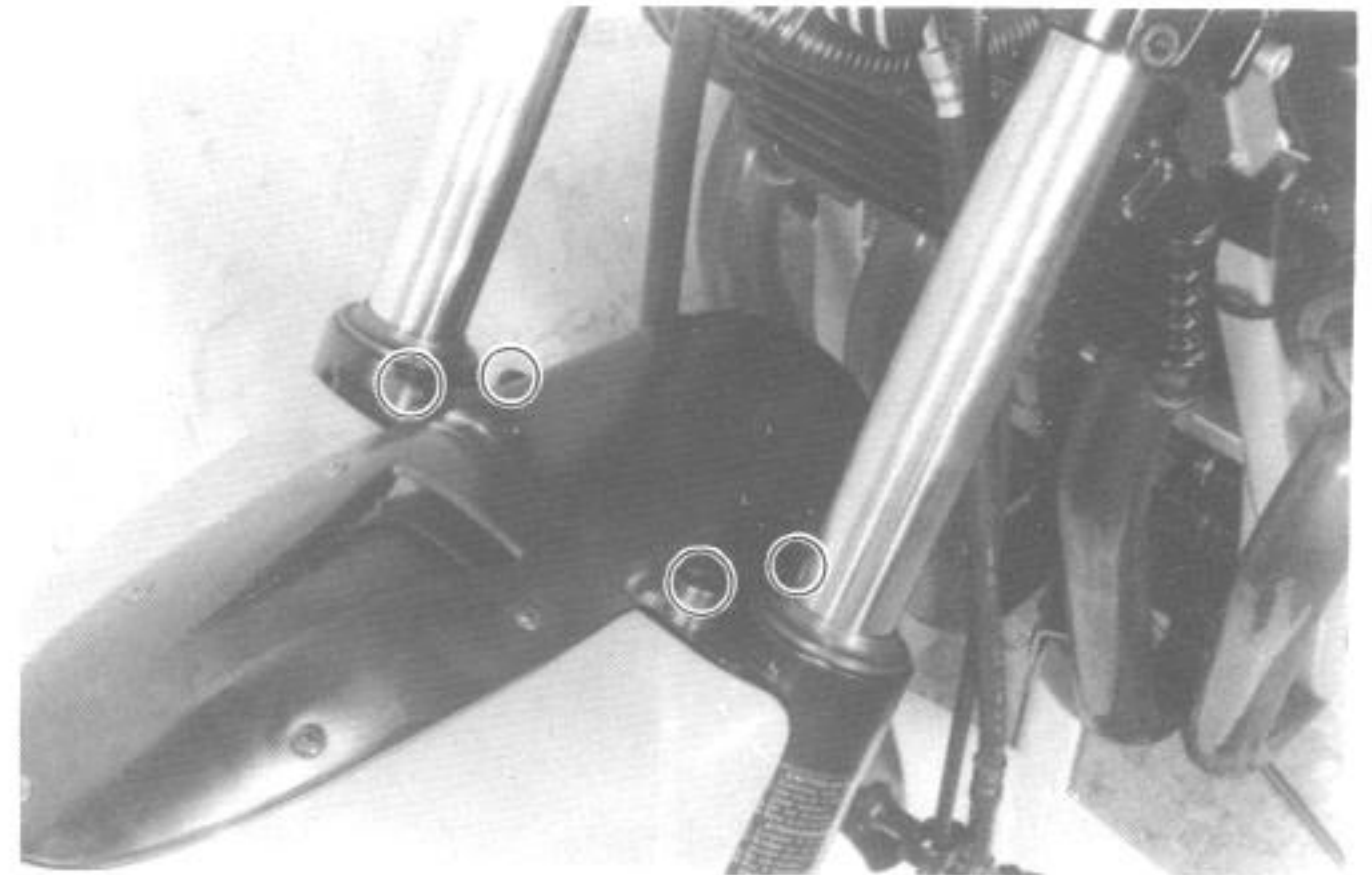

- Remove the handlebars pad screw ① and remove the pad.



- Remove the handlebar securing nuts located beneath the upper bracket, and loosen or remove the bolts ②.

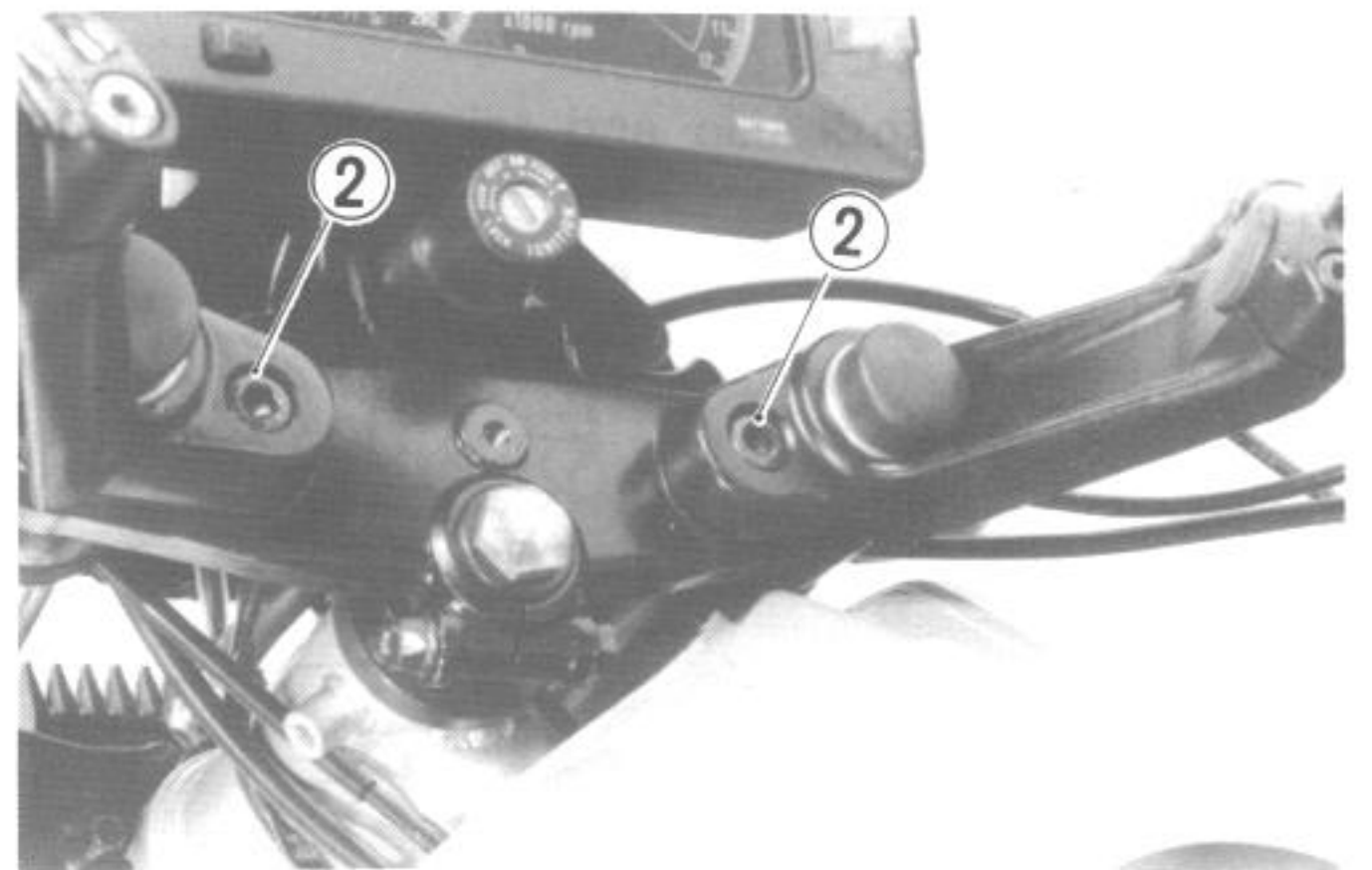

- Loosen the front fork upper clamp bolt ③ and loosen the front fork cap bolt ④.

NOTE:

Before drawing out the front fork, remove the cap ⑤ and bleed the air from the front fork.

This air fork is installed on E28 model.

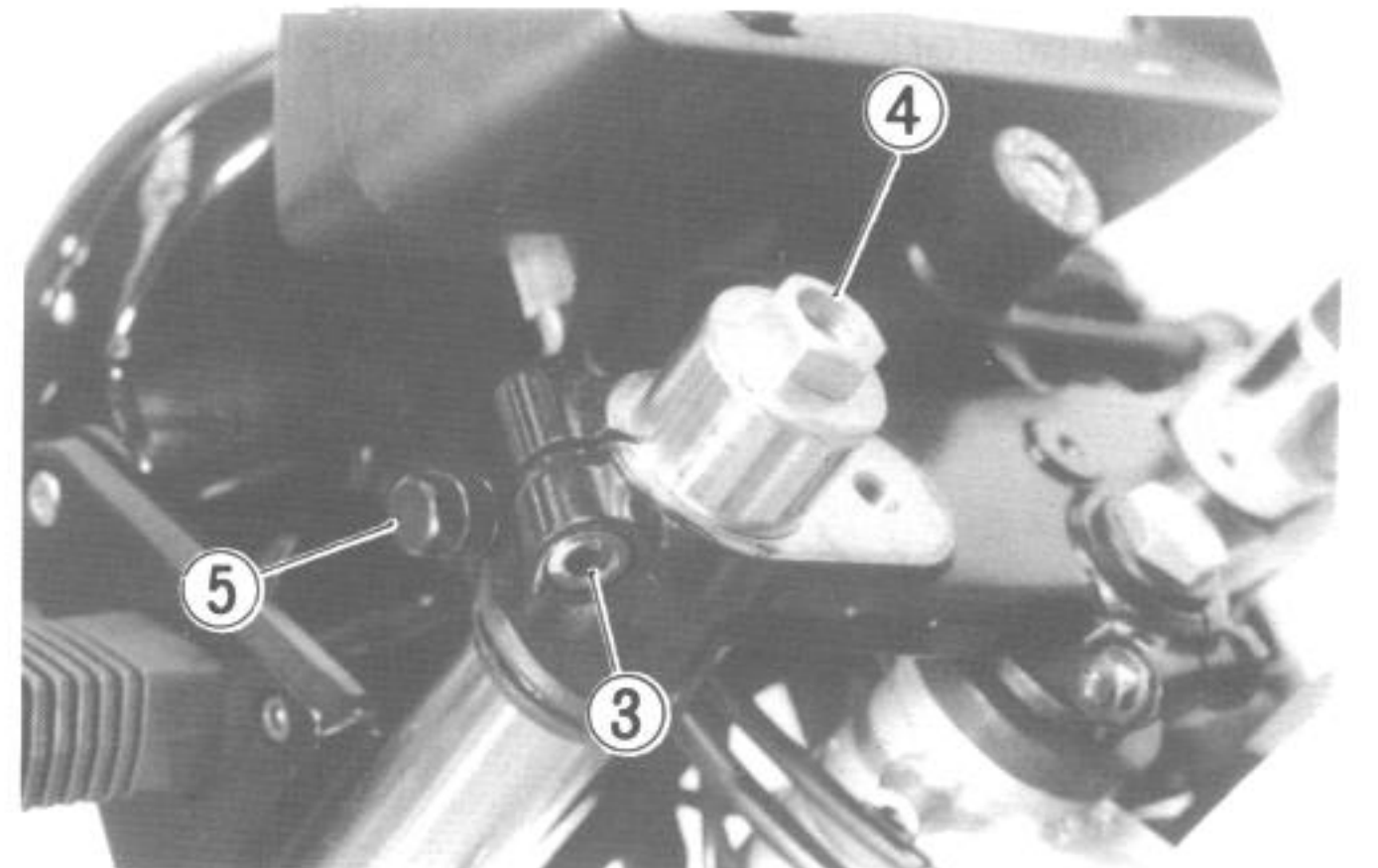

- Loosen the front fork lower clamp bolts.

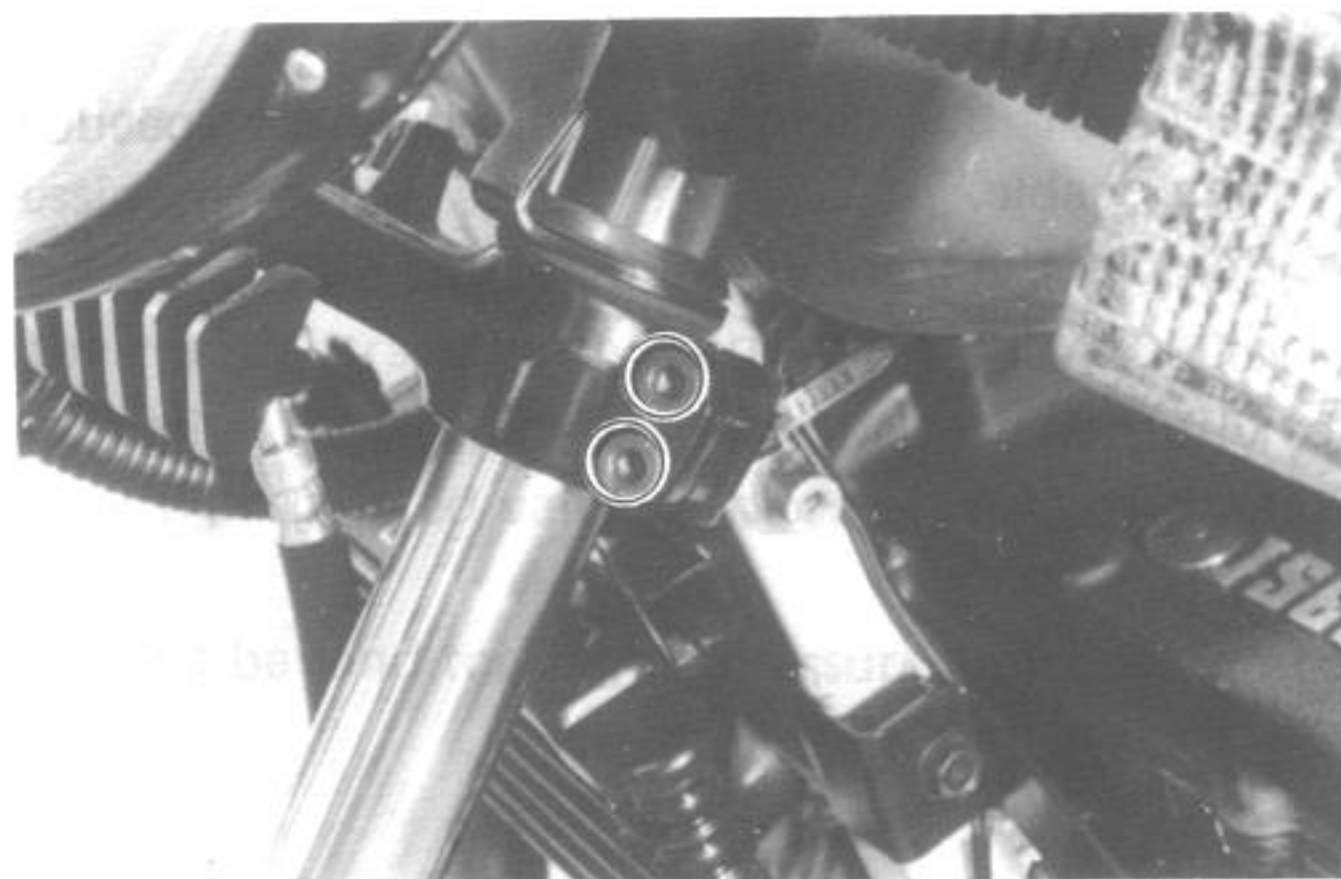

- Pull down the right and left front fork assemblies.



DISASSEMBLY

- Remove the fork cap and take off the spring and spring seat.

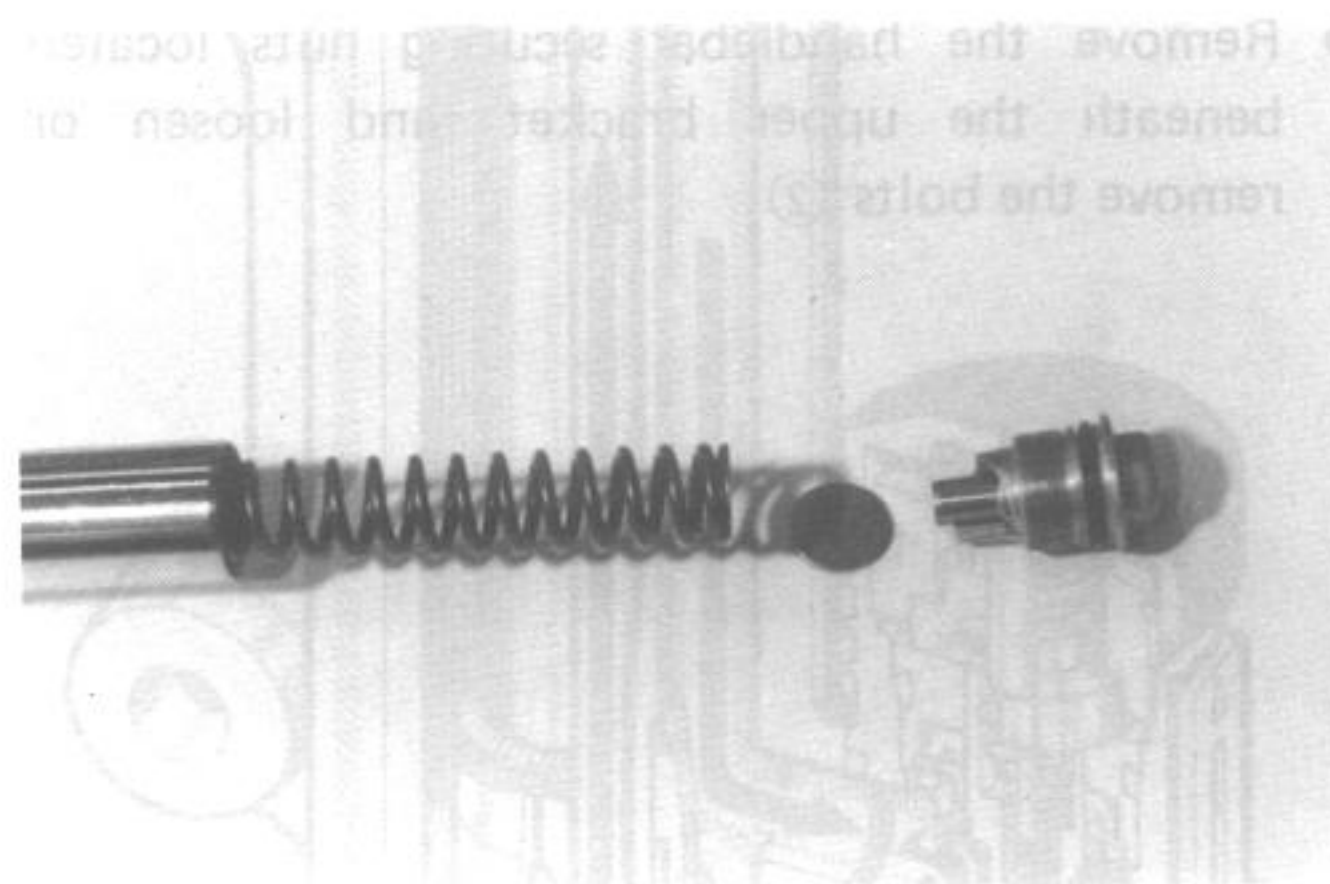

- Invert the fork and stroke it several times to remove the oil inside.
- Hold the fork inverted for a few minutes to drain the oil.

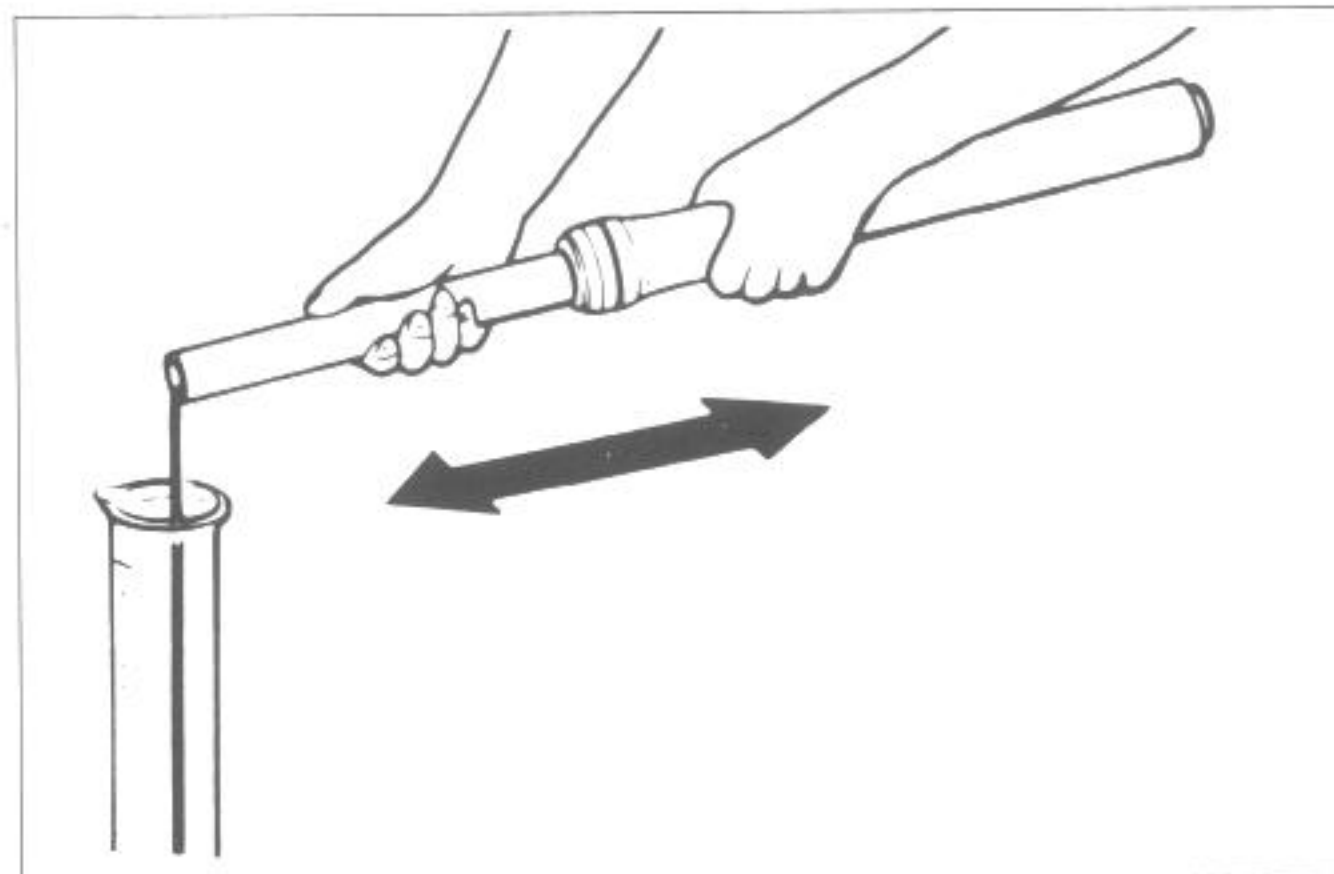

- Remove damper rod securing bolt by using special tools.
- Draw out the damper rod and rebound spring.

09940-34520	"T" handle
09940-34580	Attachment "F"
09914-25811	"T" type hexagon wrench

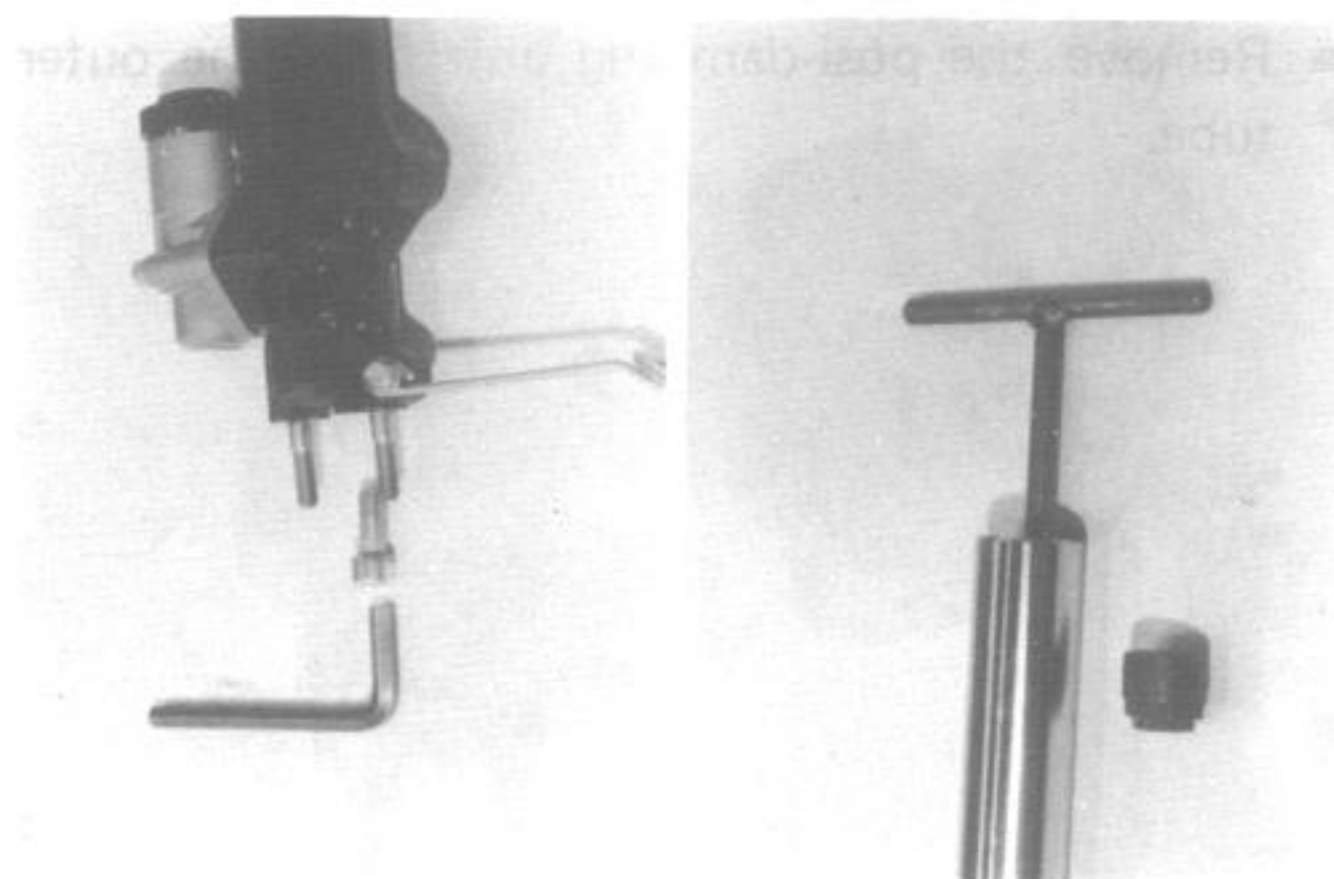

- Draw out dust seal and circlip.



- While holding the caliper mounting portion of the outer tube by vise, separate the inner tube from the outer tube as shown.

CAUTION:
The outer tube and inner tube anti-friction rings or metal slide rings must be replaced along with the oil seal any time the fork is disassembled.

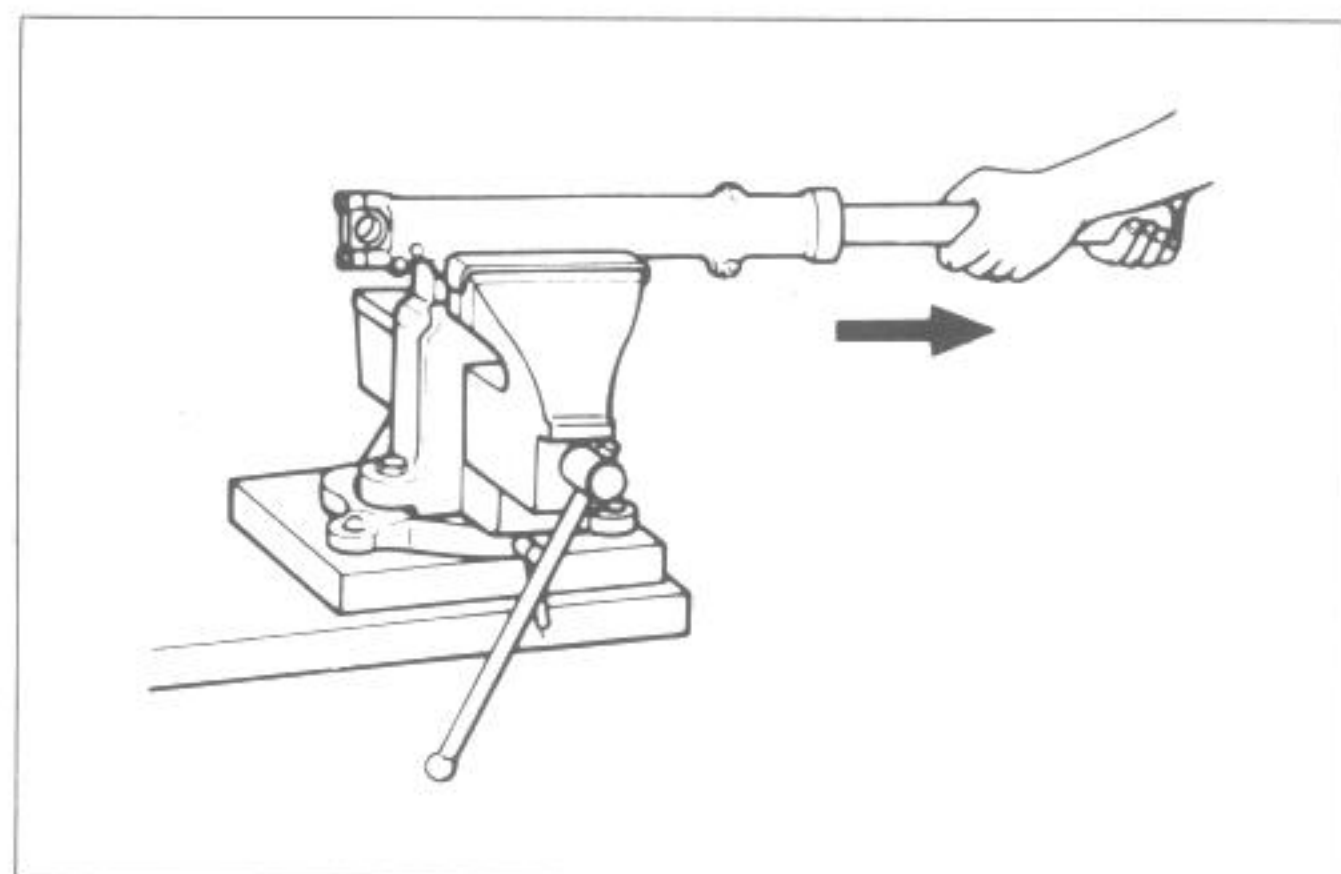

- Remove the two wave washers ①, washer ② and oil lock piece from the inner tube.

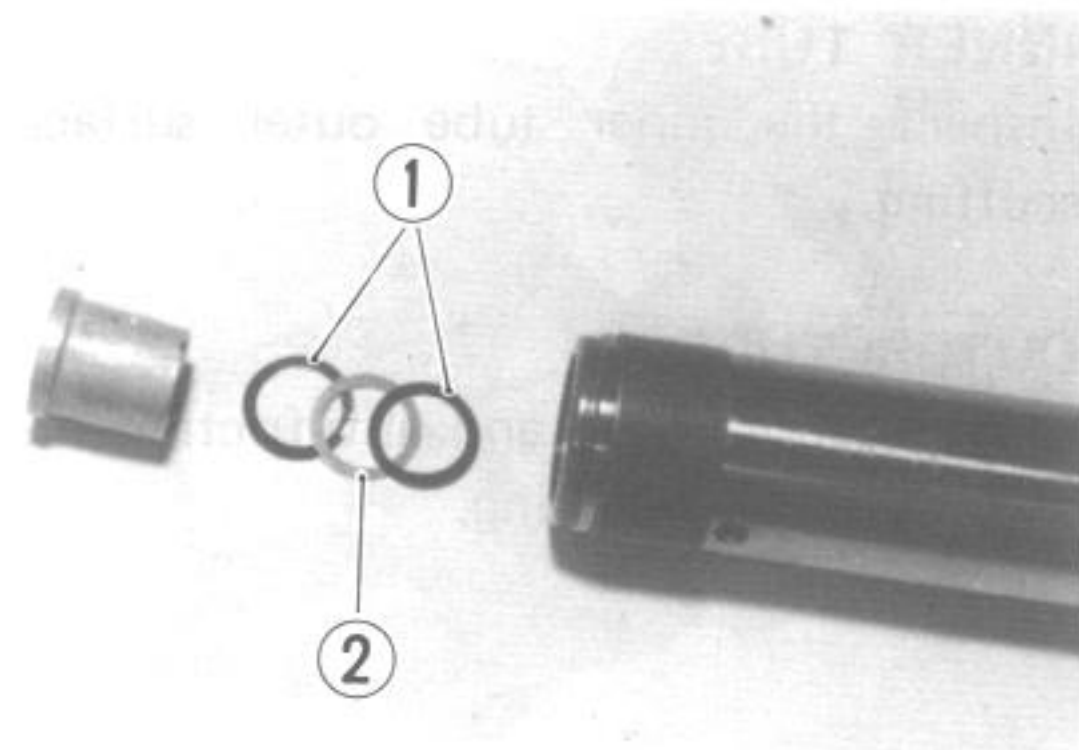

- Remove the posi-damping unit from the outer tube.

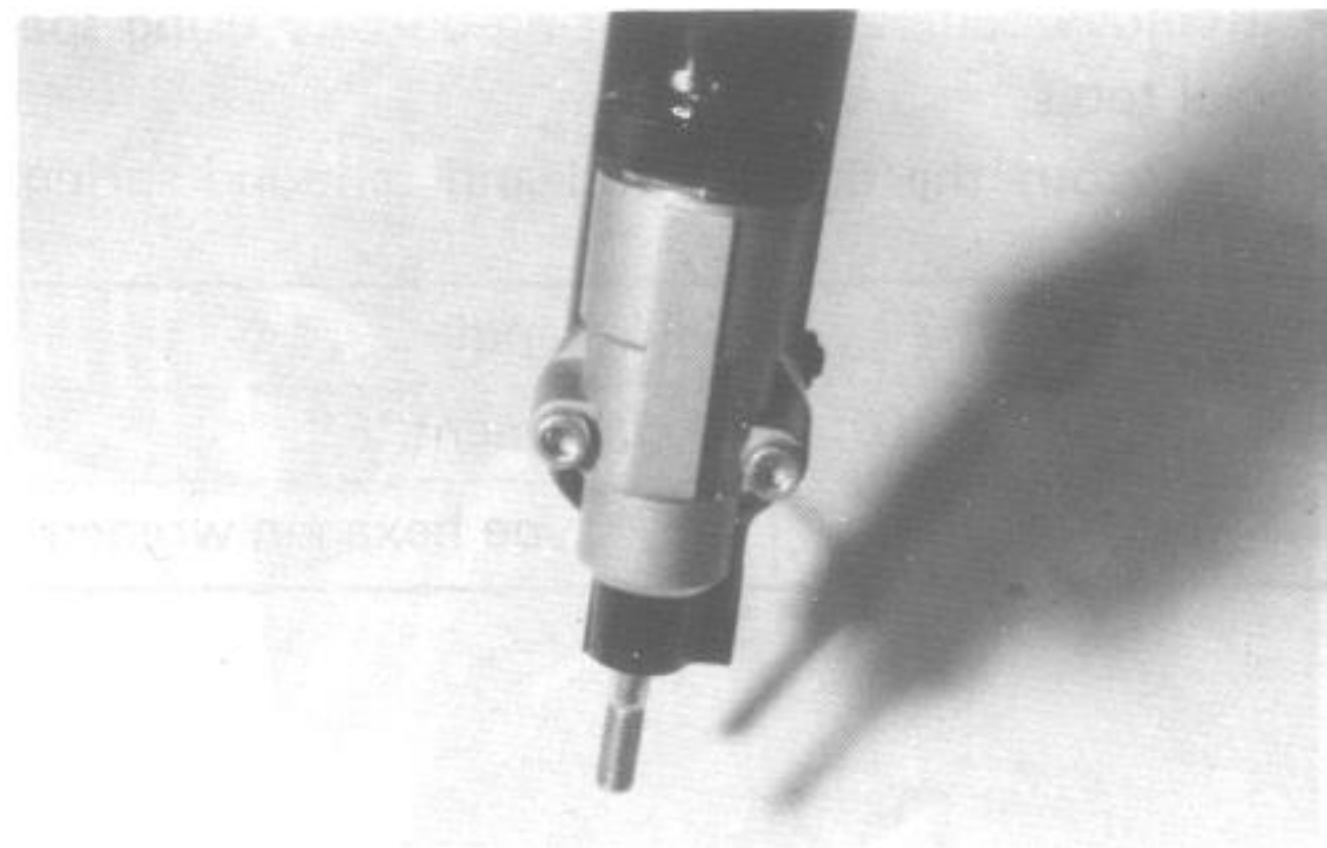

INSPECTION

DAMPER ROD RING

Inspect damper rod ring for wear and damage.

OIL LOCK PIECE

Inspect the oil lock piece and wave washers for wear and damage.

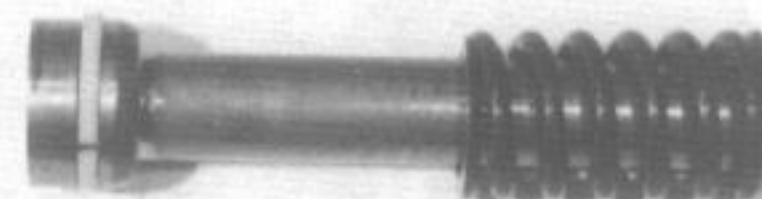

FORK SPRING

Measure the fork spring free length. If it is shorter than the service limit, replace it with a new one.

Service Limit	504 mm 500 mm (for Canada)
---------------	-------------------------------

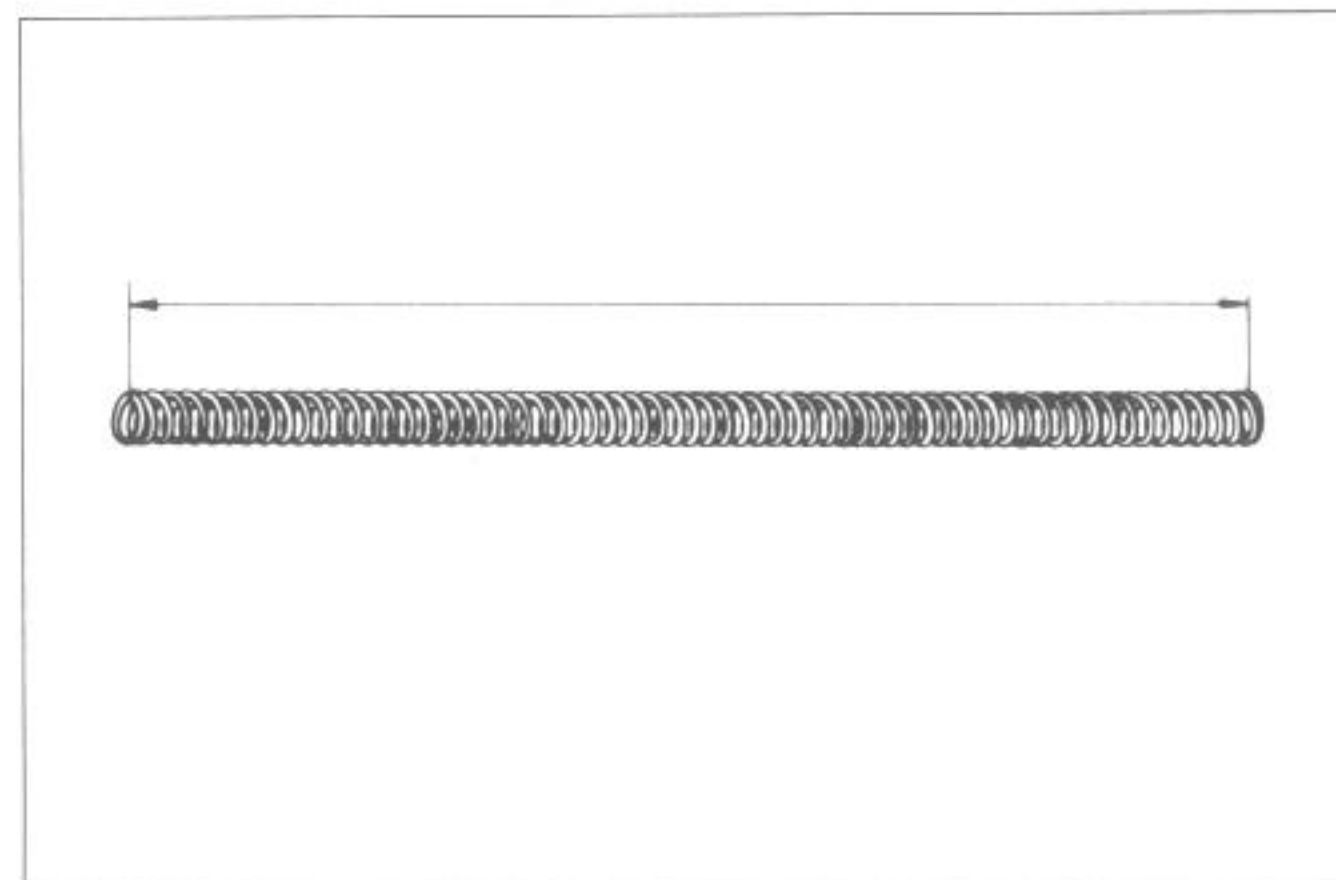

INNER TUBE

Inspect the inner tube outer surface for any scuffing.

OUTER TUBE

Inspect outer tube and anti-friction metal fitting surface for any scuffing.

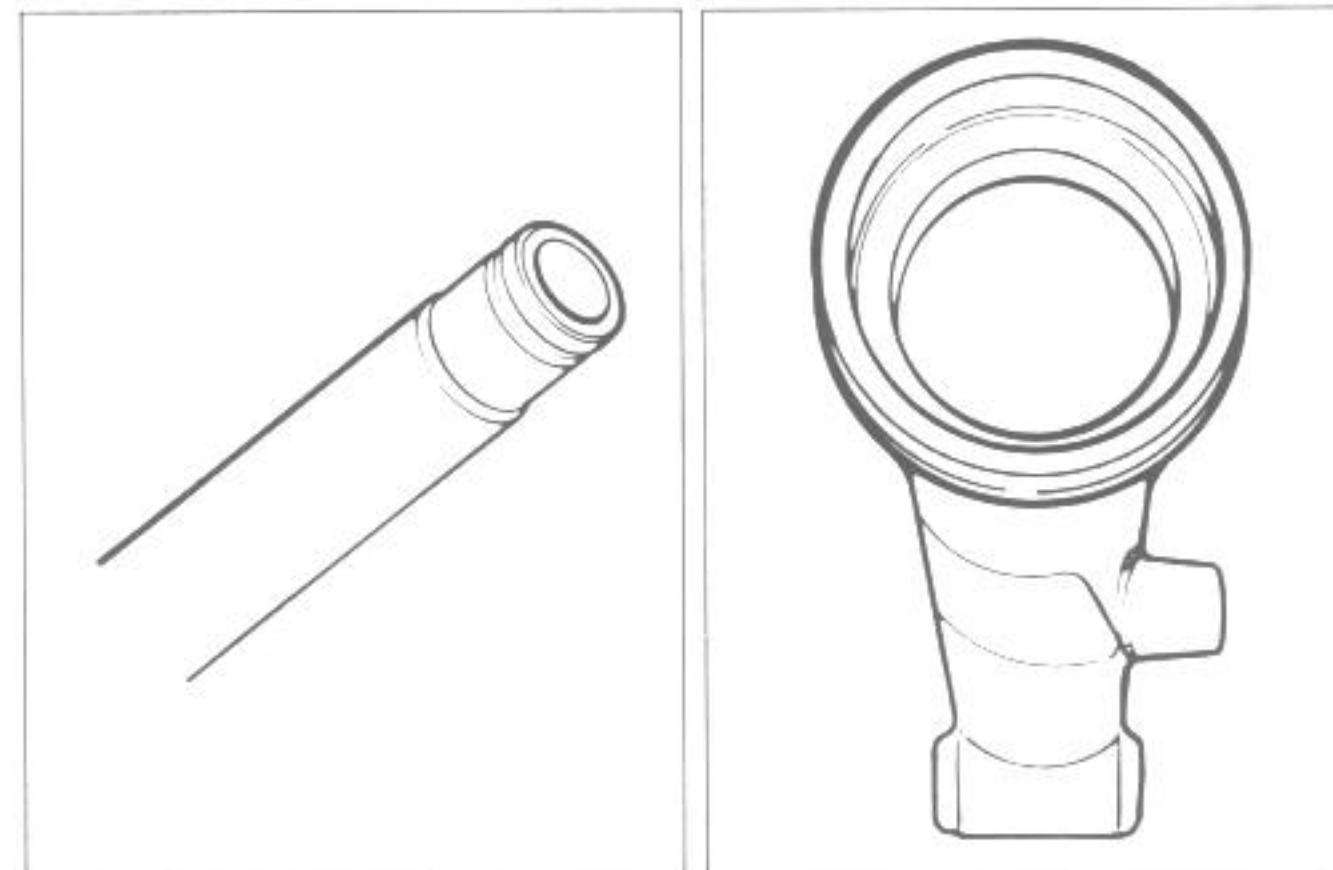

POSI-DAMPING UNIT

After separating the posi-damping unit from the outer tube, inspect the unit for leakage of fork oil. If any defect is found, replace affected unit with a new one.

NOTE:
This unit is only available as a replacement unit.

Inspect the O-rings located between unit and front fork for wear or damage.

REASSEMBLY

Reassemble and remount the front fork in the reverse order of disassembly and removal, and also carry out the following steps:

DAMPER ROD BOLT

Apply thread lock cement and SUZUKI bond No. "1207B" to the damper rod bolt. Tighten the damper rod bolt with specified torque.

99000-32040	Thread lock cement
99000-31140	SUZUKI Bond No. 1207B

Tightening torque	20 – 25 N·m (2.0 – 2.5 kg-m)
-------------------	---------------------------------

POSI-DAMPING UNIT

Apply Thread Lock 1342 to the bolts and tighten to the specified torque.

99000-32050	Thread Lock "1342"
-------------	--------------------

Tightening torque	6 – 8 N·m (0.6 – 0.8 kg-m)
-------------------	-------------------------------

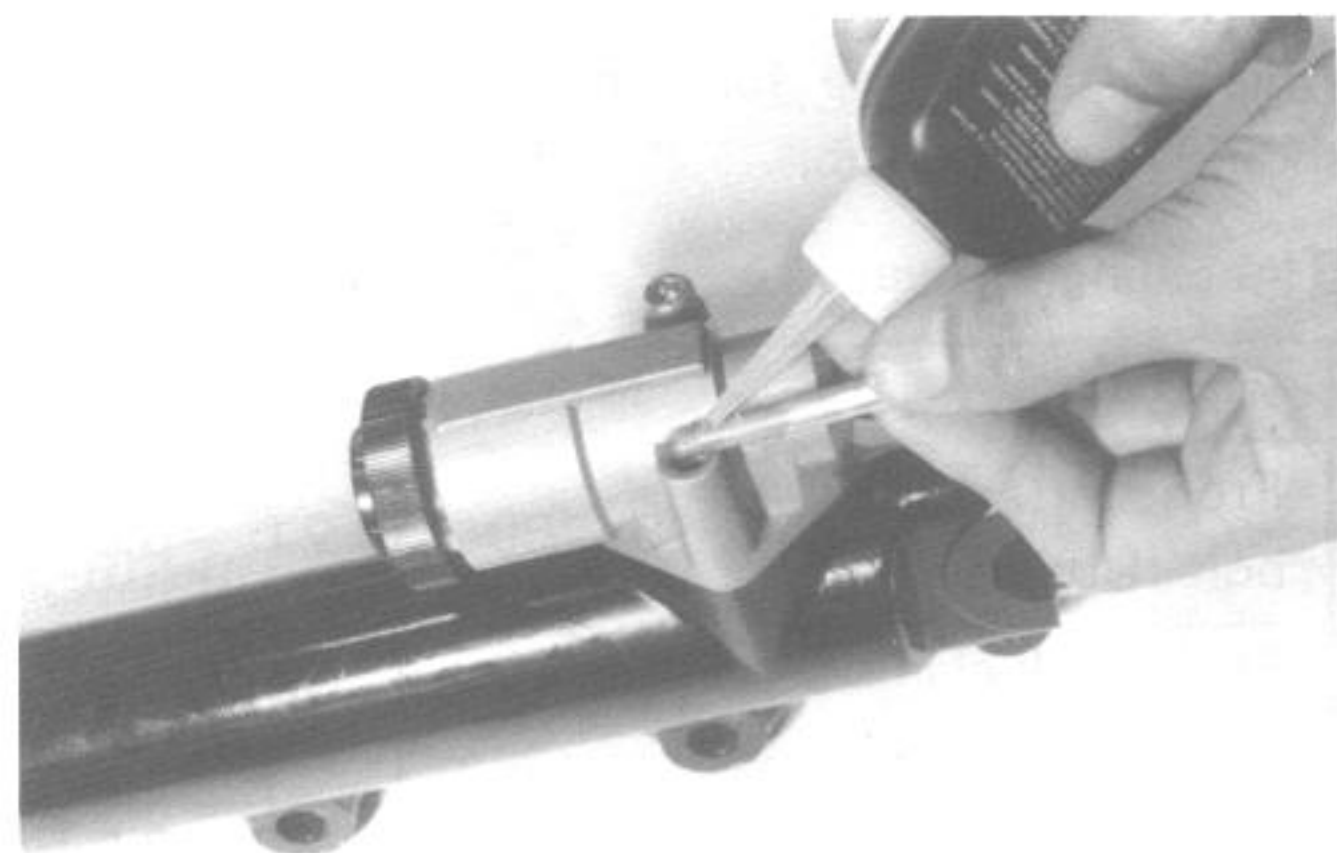
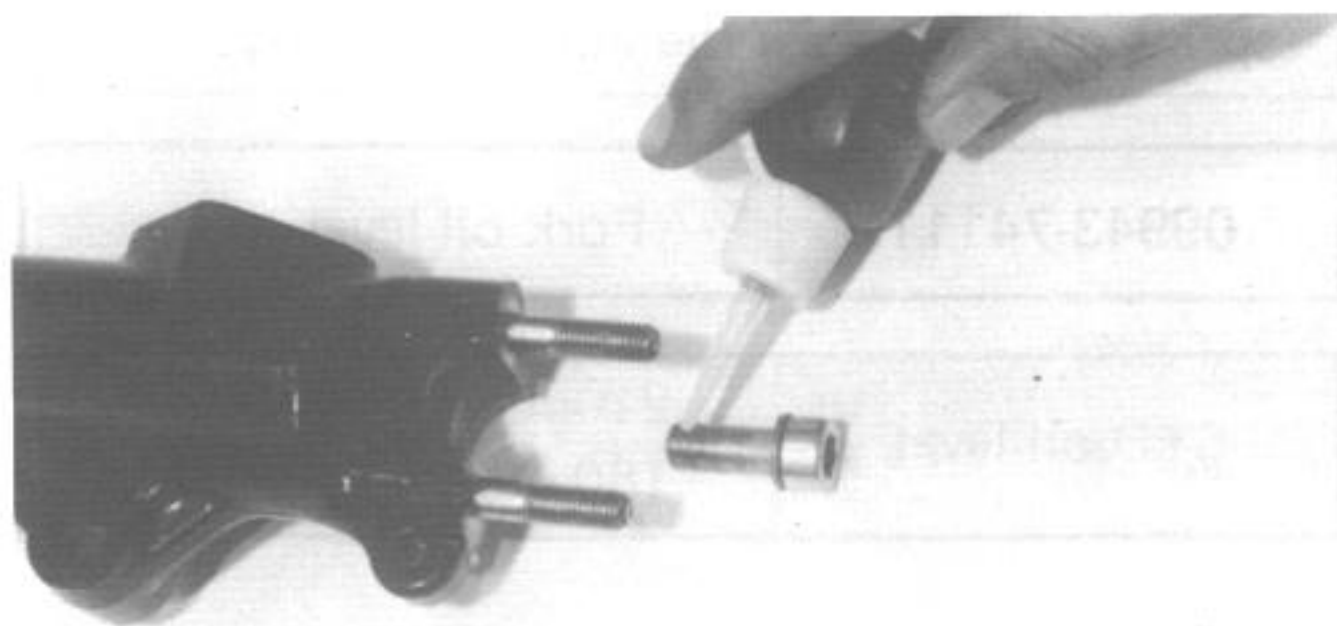
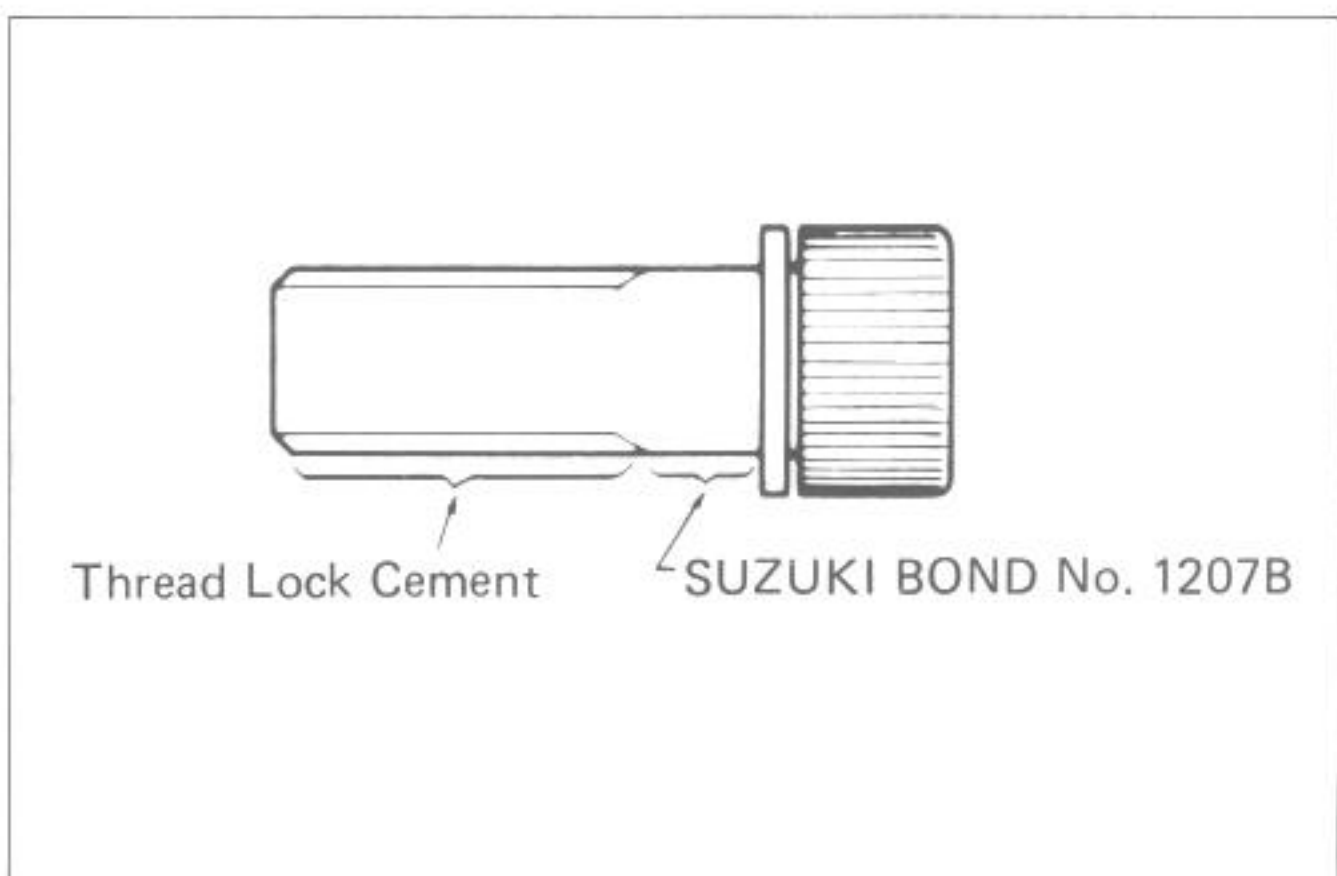
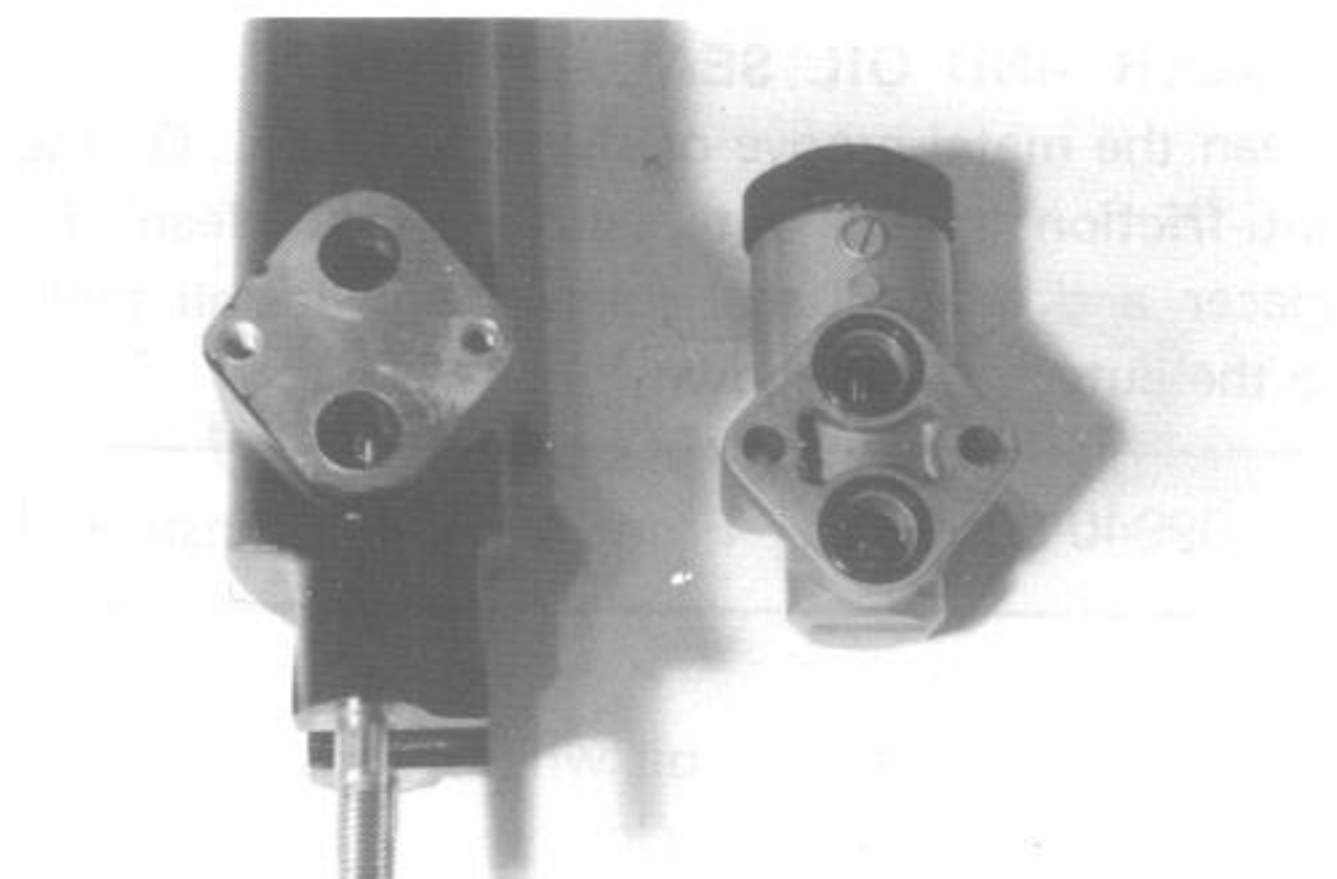

SPACER AND OIL SEAL

Clean the metal groove of the outer tube. Oil the anti-friction metal outer surface and clean the spacer and new oil seal surface, and install them to the outer tube as shown.

09940-50112	Front fork oil seal installer
-------------	-------------------------------

FORK OIL

Be sure to use a fork oil whose viscosity rating meets the specifications below.

Fork oil type	Fork oil # 15
---------------	---------------

99000-99044-15G	SUZUKI Fork oil #15
-----------------	---------------------

Fork oil capacity	268 ml 286 ml (for Canada)
-------------------	-------------------------------

Hold the front fork vertical and adjust the fork oil level with the special tool.

NOTE:
When adjusting oil level, remove the fork spring and compress the inner tube fully.

09943-74111	Fork oil level gauge
-------------	----------------------

STD oil level	210 mm 180 mm (for Canada)
---------------	-------------------------------

FORK SPRING

When installing the fork spring, small pitch end should position in top.

Tightening torque:

	N·m	kg-m
Front fork clamp bolt (Upper)	20 – 30	2.0 – 3.0
Front fork clamp bolt (Lower)	15 – 25	1.5 – 2.5
Damper rod bolt	20 – 25	2.0 – 2.5

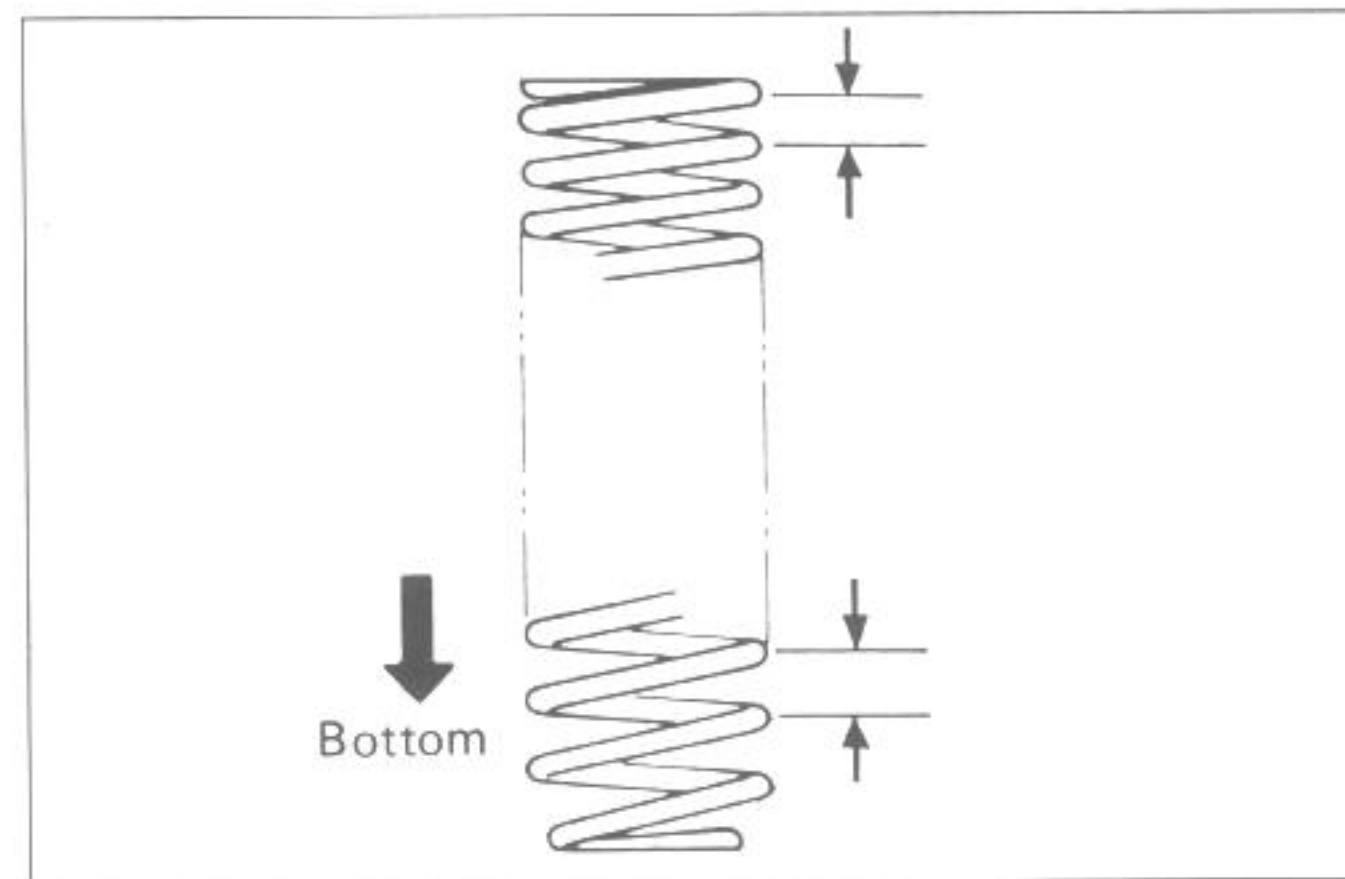
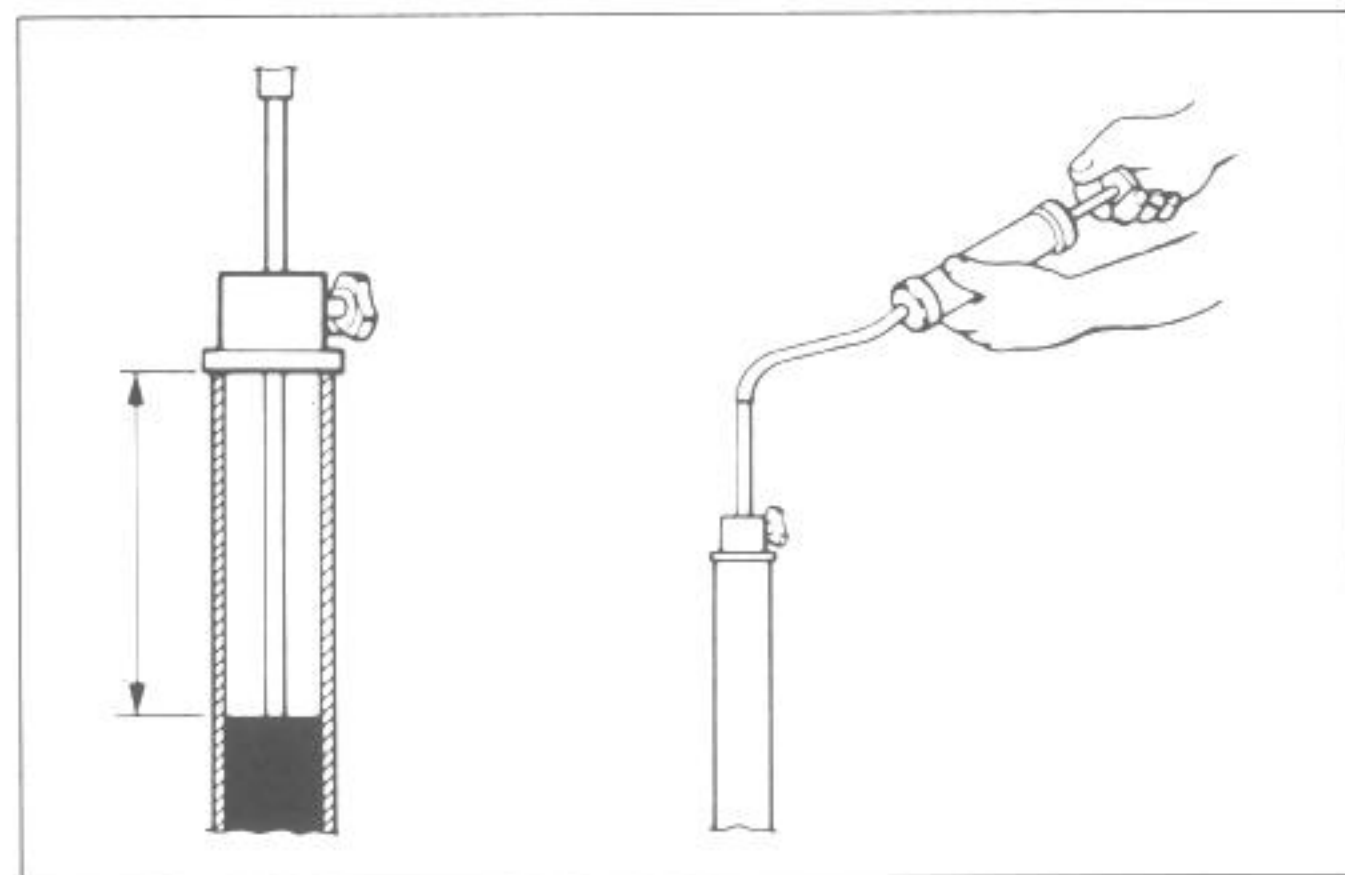
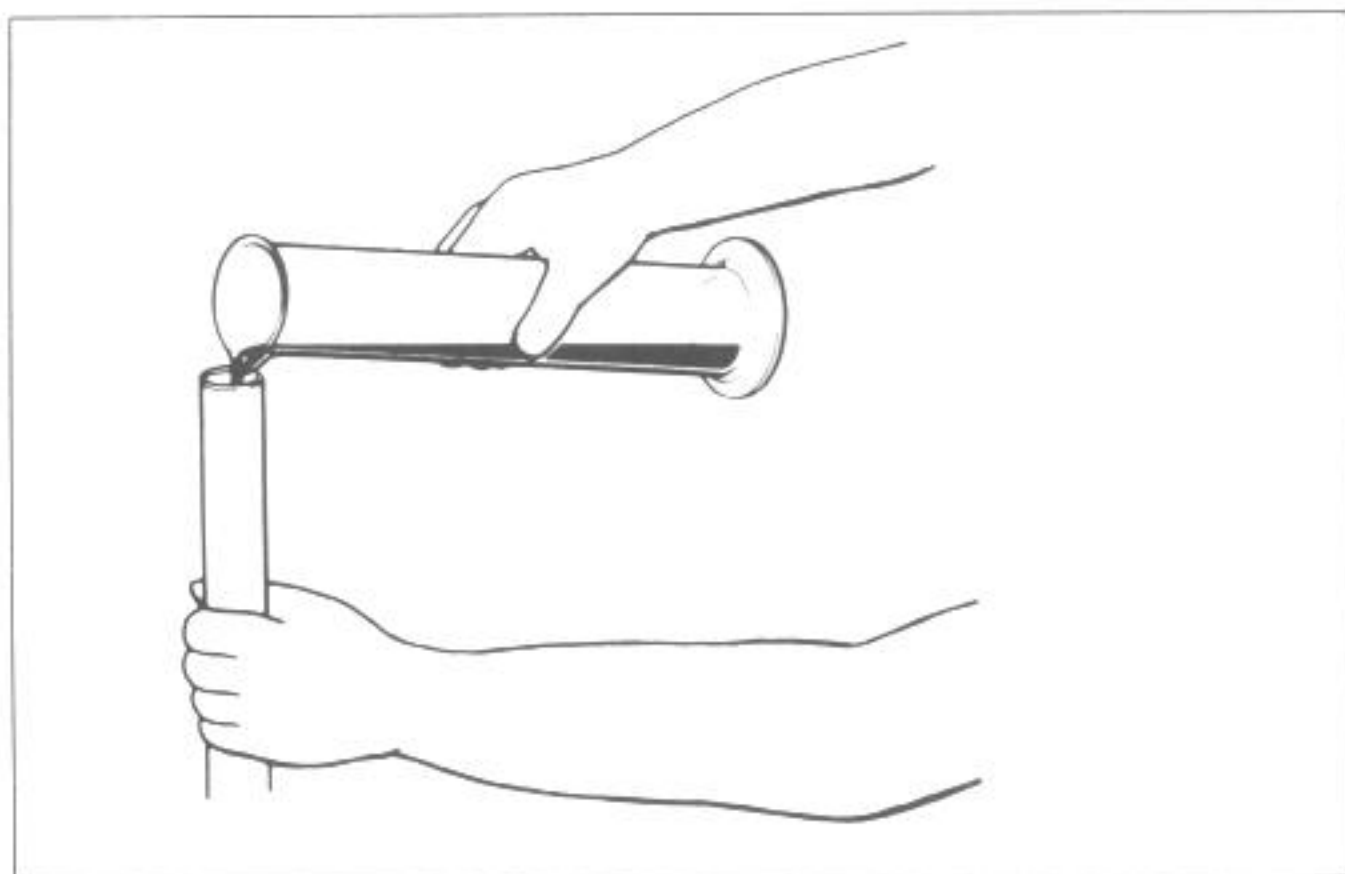

AIR JOINT (only for Canada)

- Before installing the front fork, thoroughly inspect the air joint O-rings for wear or damage.

- When installing the air joint, position the air cap in front of the left fork.

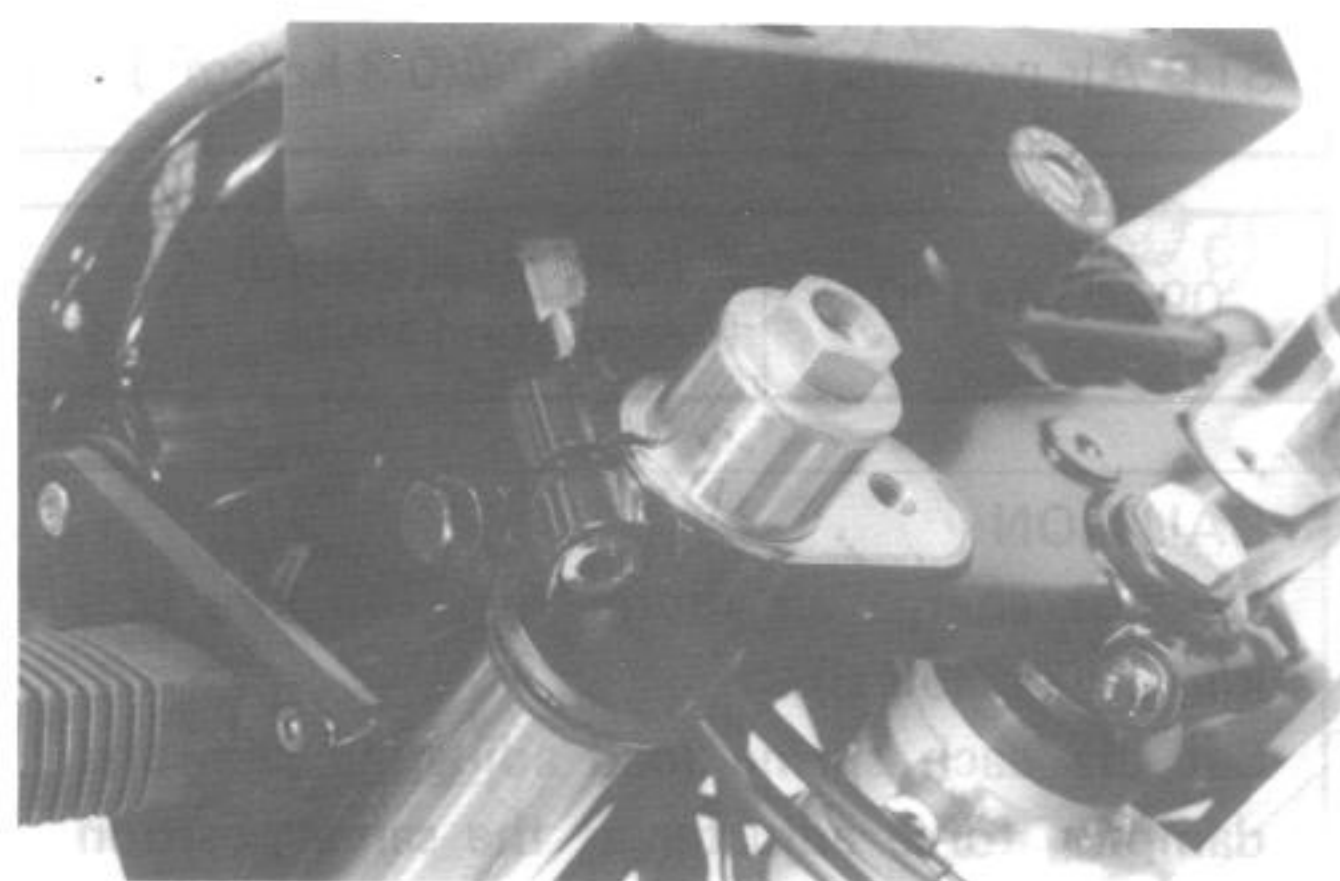
**DAMPING FORCE AND SPRING SETTING**

Before installing front fork to the steering stem, be sure to check the spring adjuster setting position and damping force adjuster.

Standard Setting

Specification	Damping force	Spring
Canada	"3" 3rd position	"2"
The others	"3" 3rd position	"1" softest

CAUTION:

When changing the damping force or spring preload, refer to page 6-60 for proper setting.

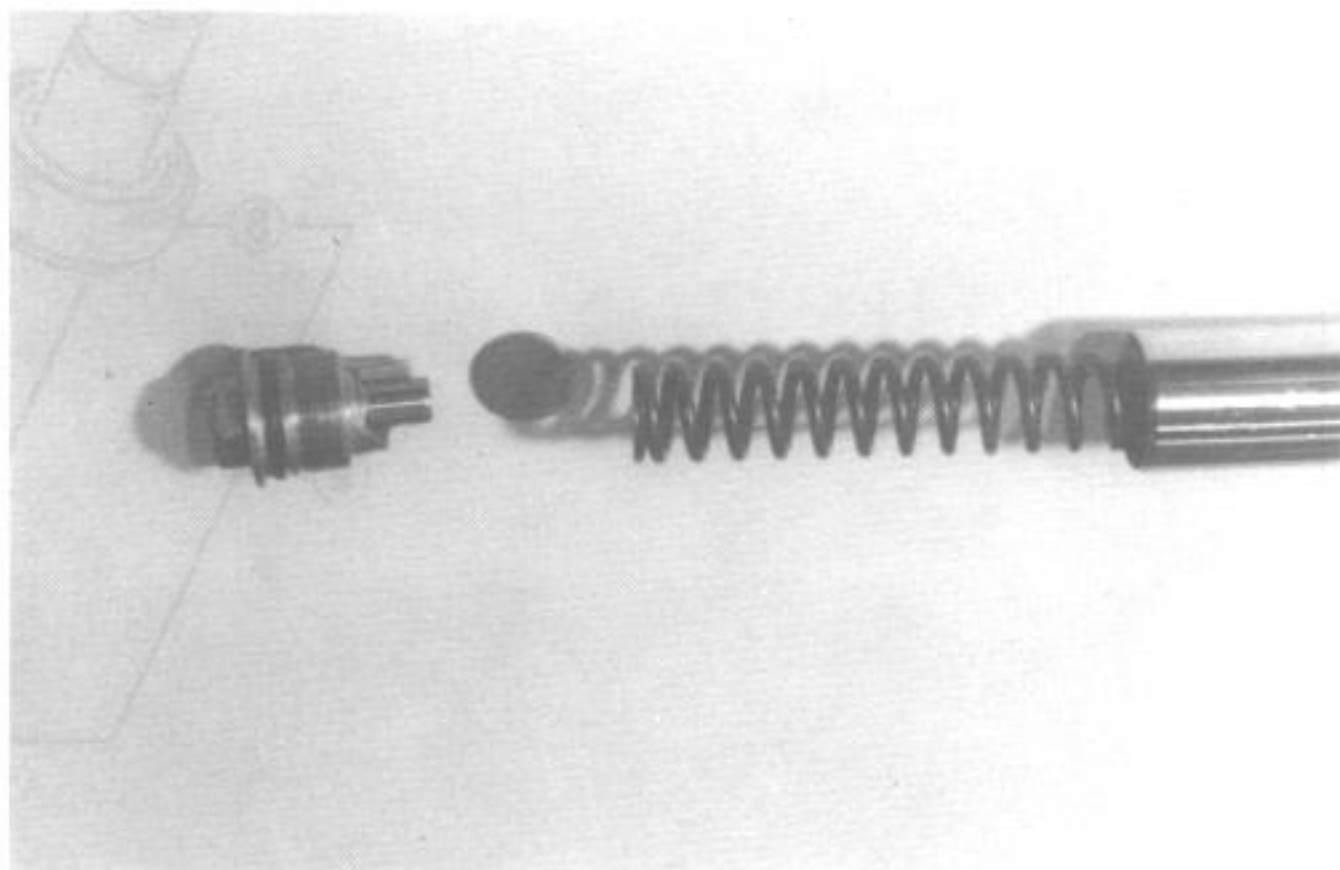
**INNER TUBE**

When installing the front fork assembly, align upper surface ① of the inner tube with the upper surface ② of the handlebars.

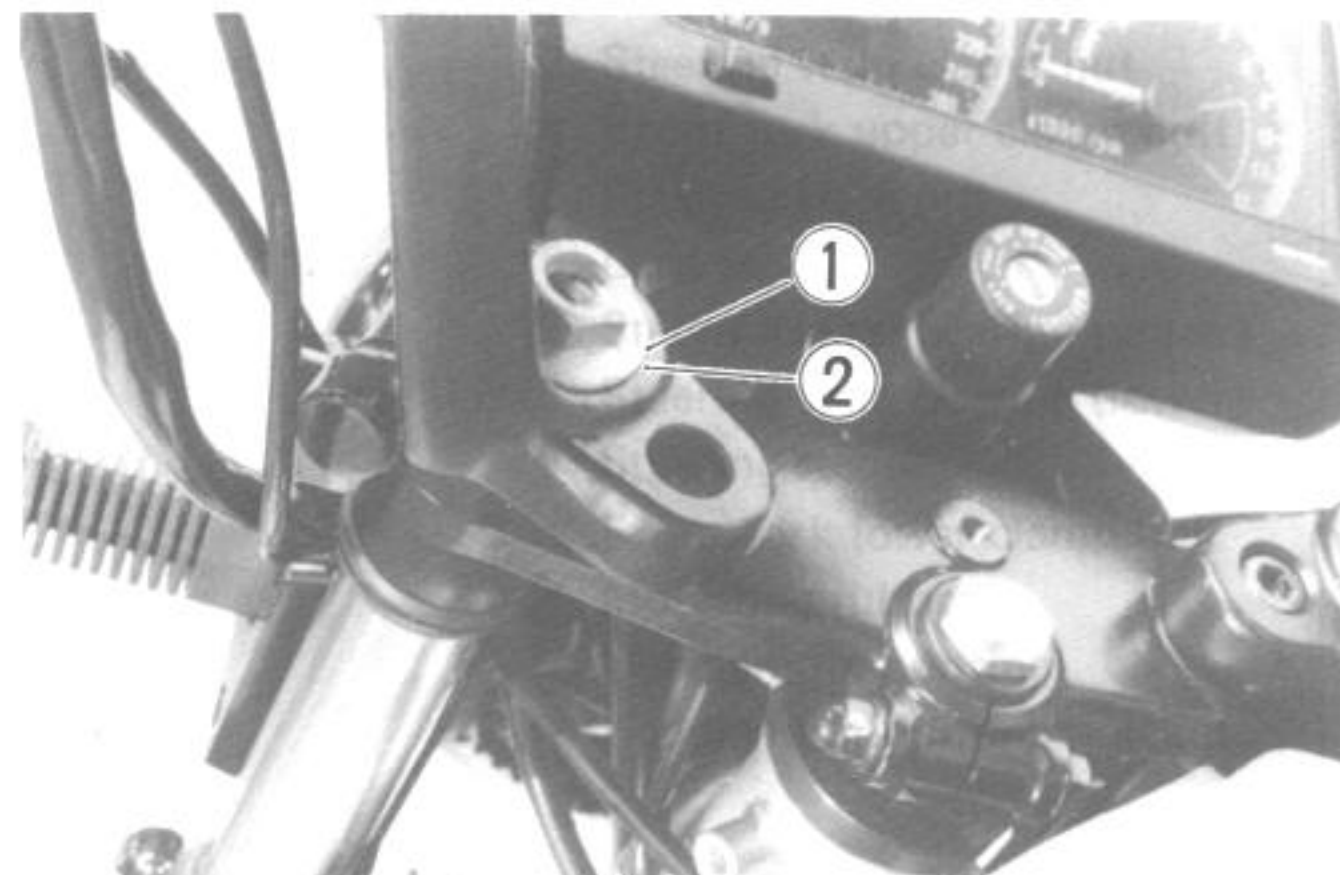

FORK AIR (only for Canada)

Lift up the front wheel by a jack till it becomes free from any burden, and remove the air valve cap ①.

Set the air pressure gauge to the valve ② and turn the valve handle ③ clockwise. Set the hand pump to the gauge; and charge the air.

Let the air out by loosening the handle ③ till the specified air pressure is left inside, and remove the pressure gauge.

STD Air pressure	30 kPa (0.3 kg/cm ²)
------------------	----------------------------------

09940-44120	Fork air pressure regulating gauge
-------------	------------------------------------

CAUTION:

Do not charge air more than 245 kPa (2.5 kg/cm² or 35 psi).

Set the each spring load adjusting cam and damping force adjuster at the same position for both right and left forks.

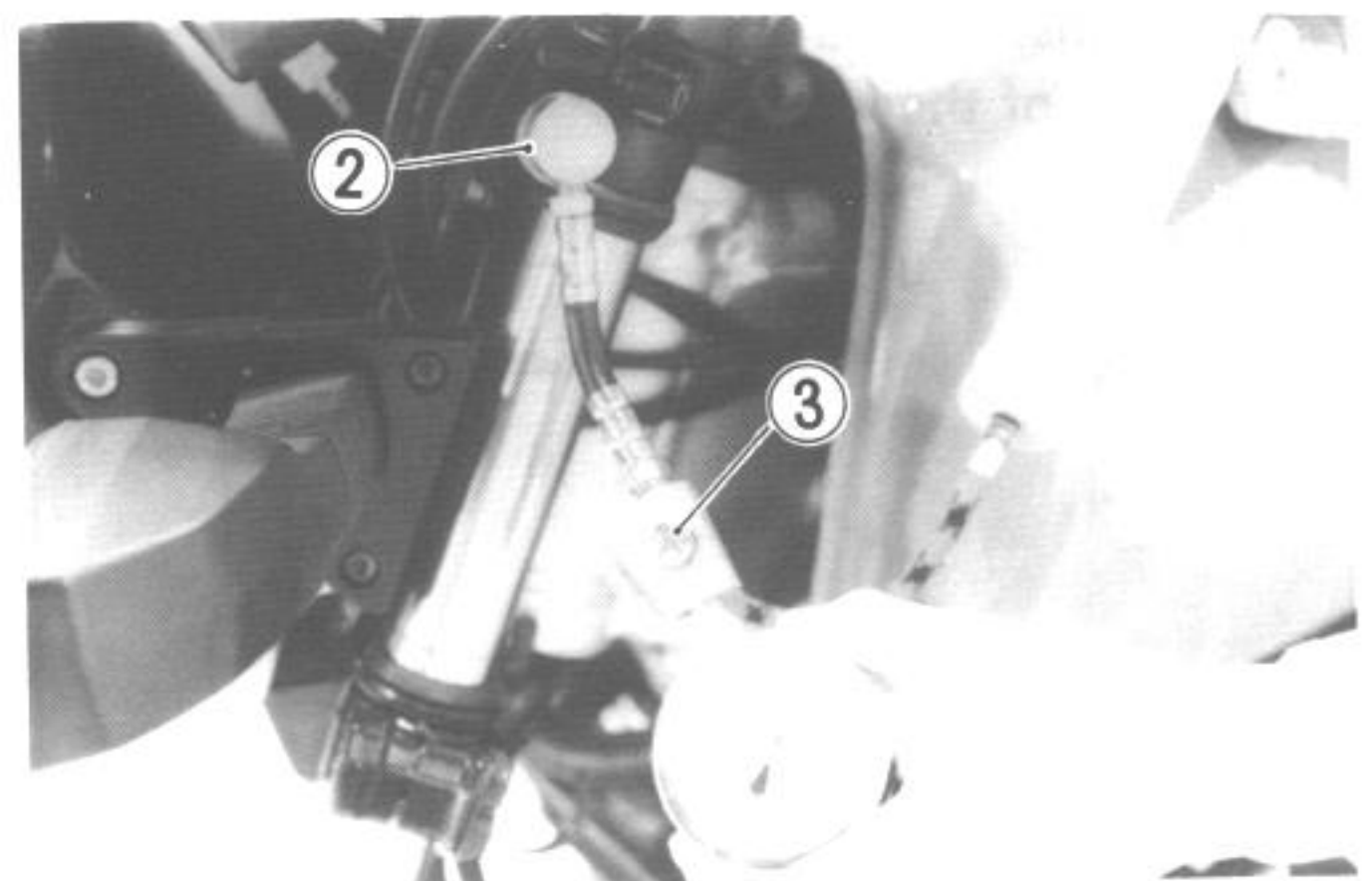
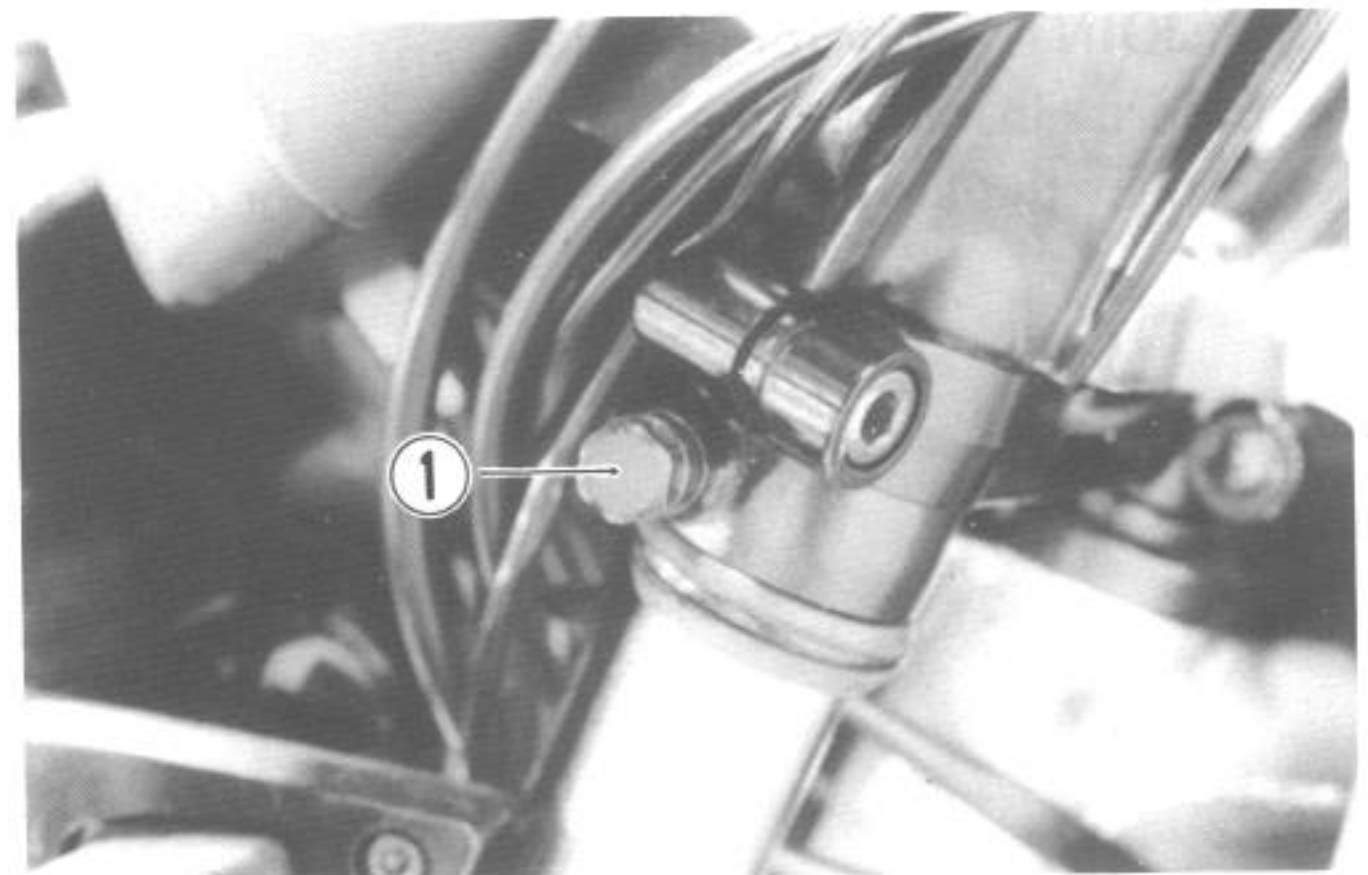

STEERING STEM

CONSTRUCTION

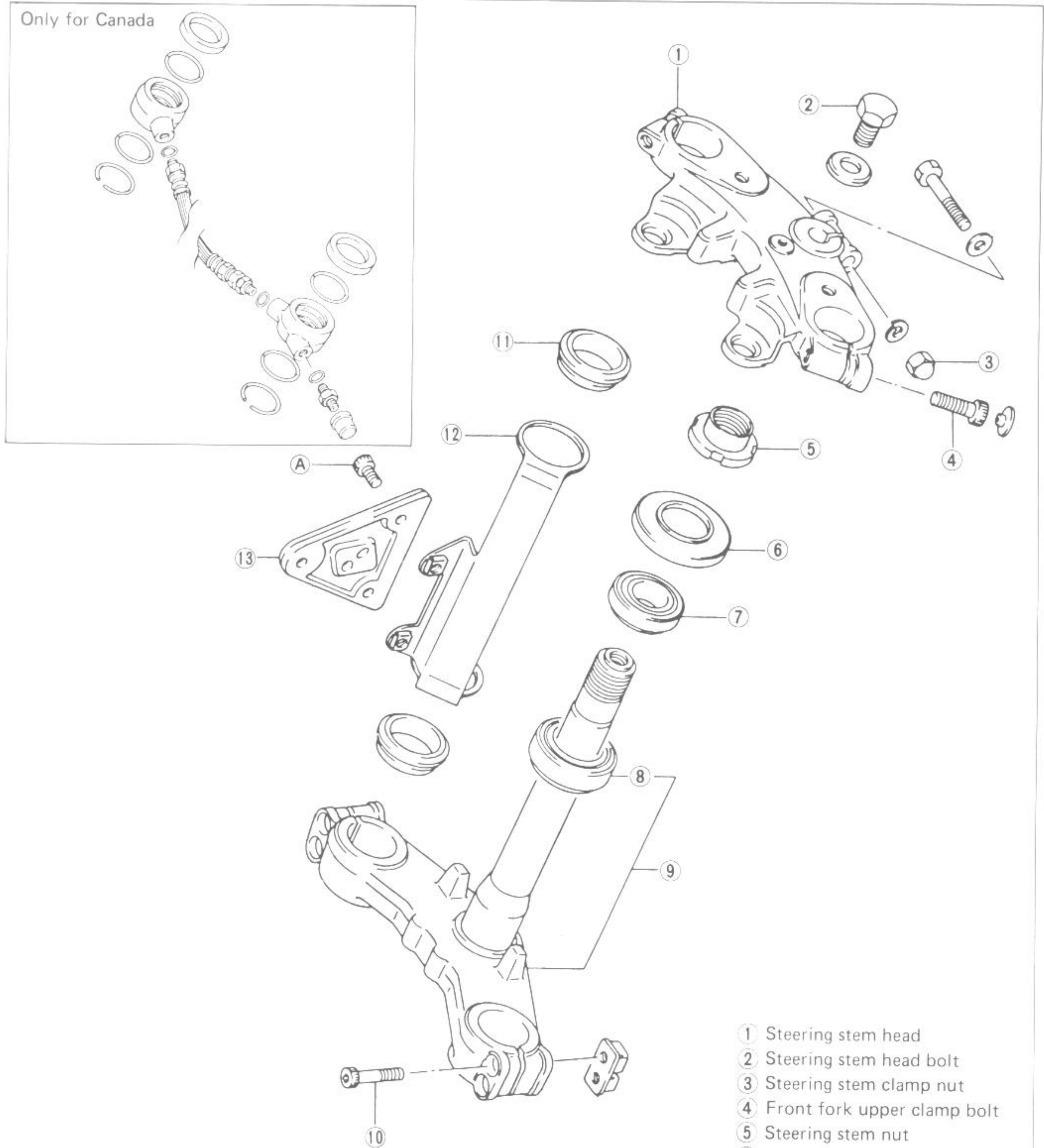

Tightening torque		
Item	N·m	kg·m
②	20 – 30	2.0 – 3.0
③	15 – 25	1.5 – 2.5
④	20 – 30	2.0 – 3.0
⑩	15 – 25	1.5 – 2.5

- ① Steering stem head
- ② Steering stem head bolt
- ③ Steering stem clamp nut
- ④ Front fork upper clamp bolt
- ⑤ Steering stem nut
- ⑥ Dust seal
- ⑦ Steering stem bearing (upper)
- ⑧ Steering stem bearing (lower)
- ⑨ Steering stem
- ⑩ Front fork lower clamp bolt
- ⑪ Mounting rubber
- ⑫ Headlamp mounting
- ⑬ Headlamp mounting bracket

REMOVAL

- Remove the seat and fuel tank (Refer to page 3-2).
- Remove the front wheel (Refer to page 6-2).
- Remove the front fork (Refer to page 6-16).
- Remove the both handlebars (Refer to page 6-16).
- Remove the speedometer cable and speedometer assembly.



- Disconnect the speedometer coupler from the speedometer assembly.

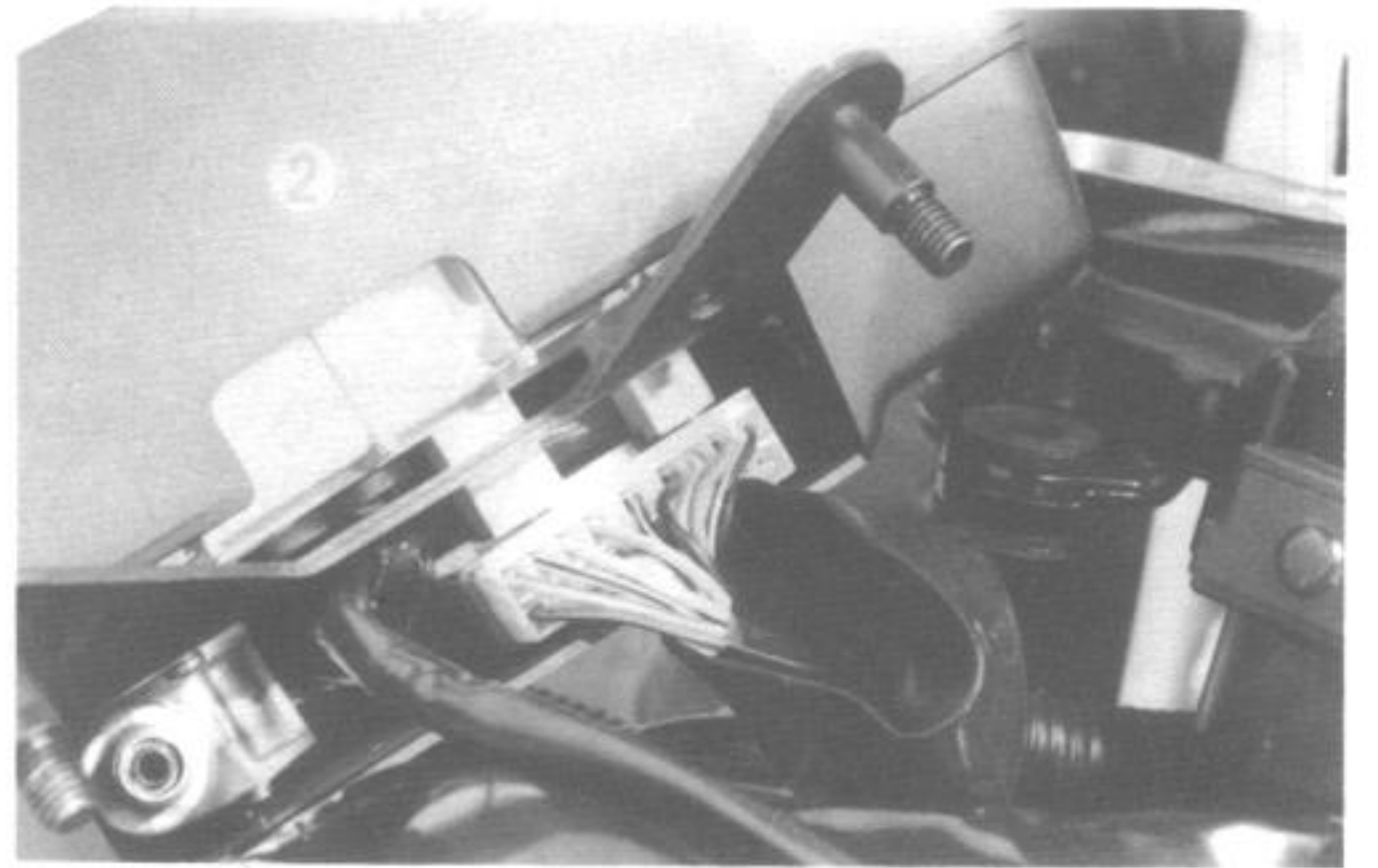

- Remove the headlight and disconnect the lead wire couplers.



- Remove the brake hose connectors from the lower bracket.



- Remove the steering stem head bolt and loosen the clamp nut, then take off the steering stem upper bracket.

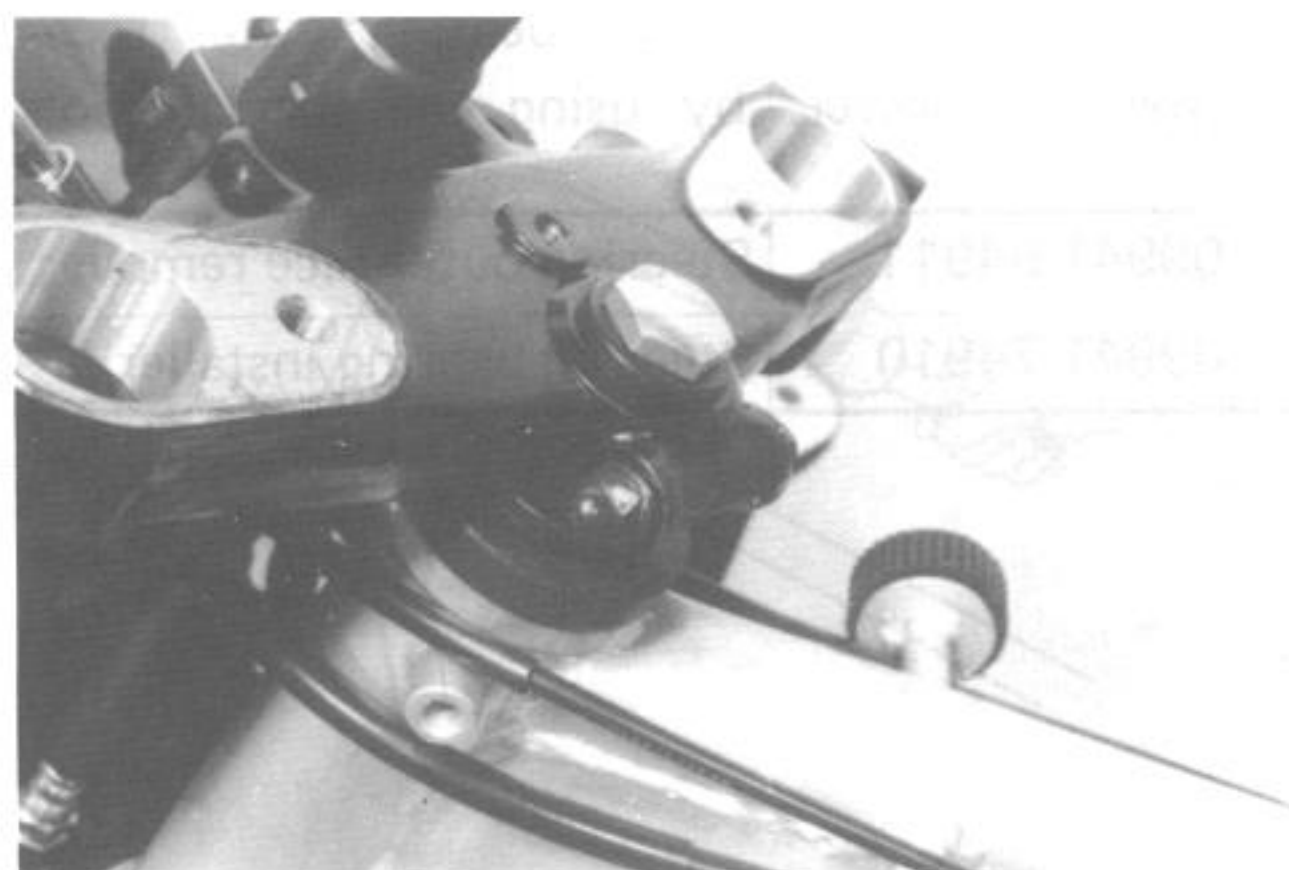

- Disconnect the coupler and remove the ignition switch by using the 5 mm hexagon wrench.

09911-73730

T type hexagon wrench
(5 mm)

- Remove the steering stem nut by using the special tool, then draw out the steering stem.

09910-60611

Universal clamp wrench

NOTE:

Hold the steering stem lower bracket by hand to prevent it from falling.



- Draw out lower steering stem bearing by using the special tool.

CAUTION:

The removed bearing should be replaced.

09941-84510

Bearing remover

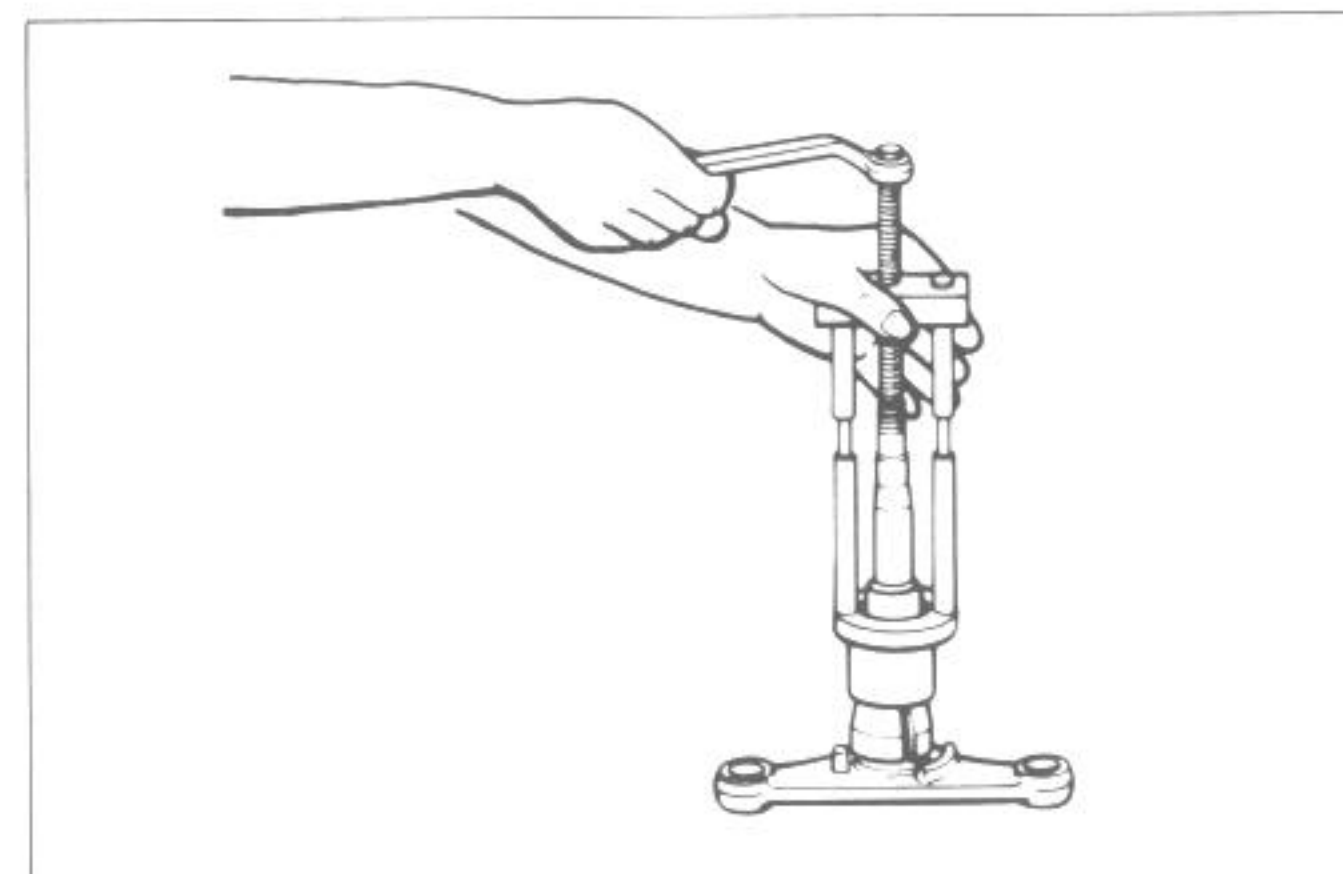

- Push out steering stem bearing outer races, upper and lower, by using the special tools.

09941-54911	Steering outer race remover
09941-74910	Steering bearing installer

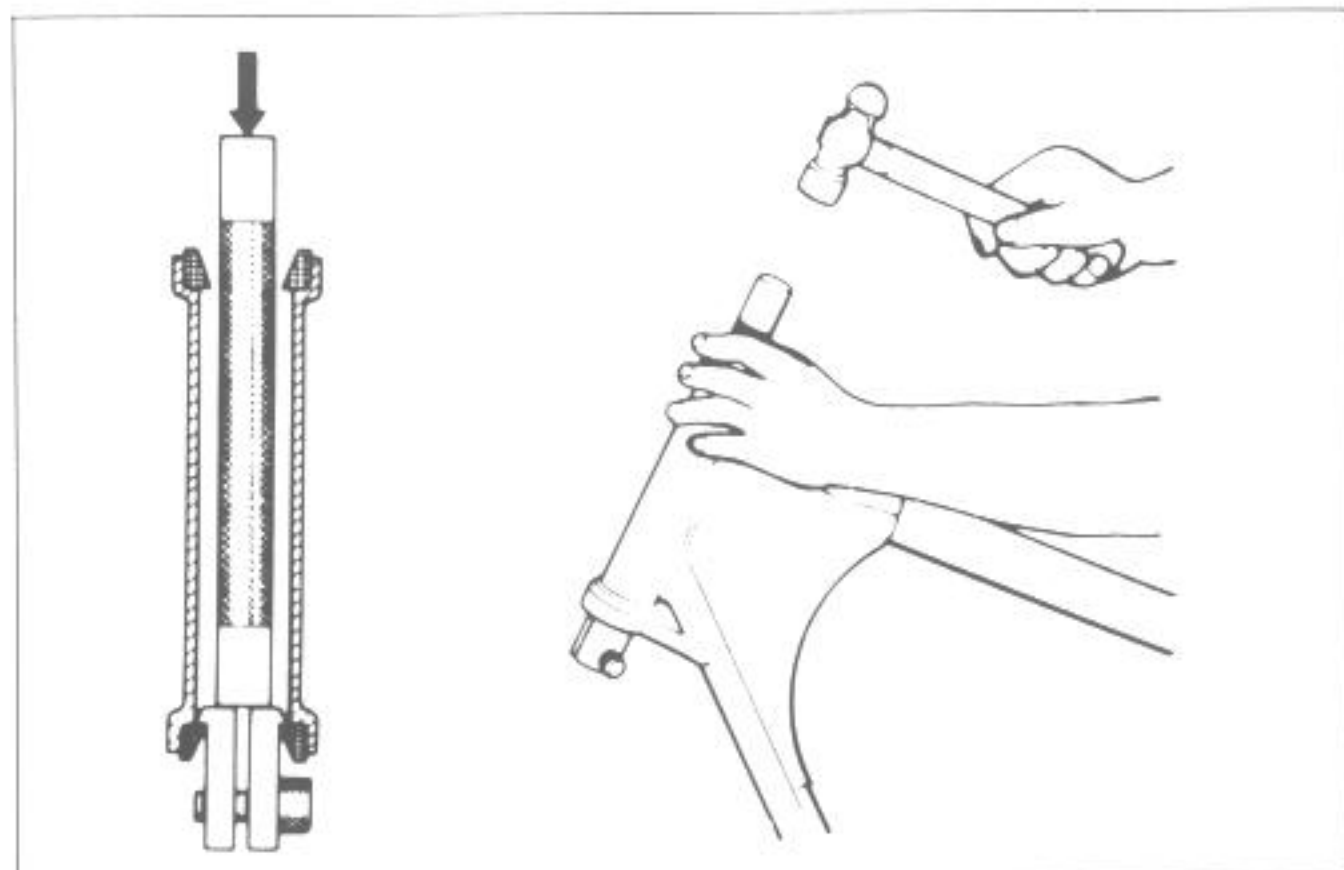

REASSEMBLY

Reassemble and remount the steering stem in the reverse order of disassembly and removal, and also carry out the following steps:

OUTER RACES

Press in the upper and lower outer races using the special tool.

09941-34513	Steering outer race installer
-------------	-------------------------------

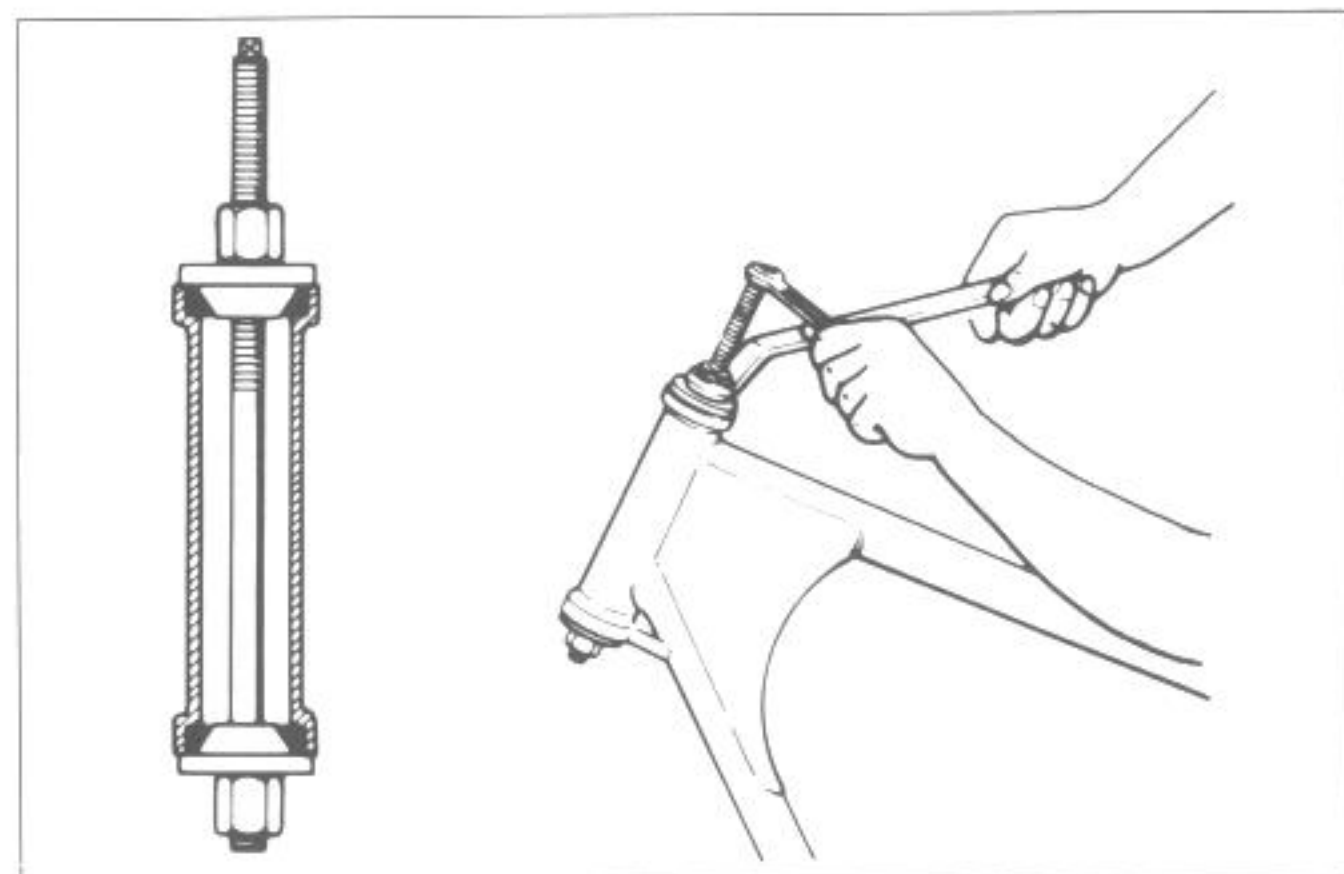

BEARING

Press in the lower bearing by using the special tool.

09941-74910	Steering bearing installer
-------------	----------------------------

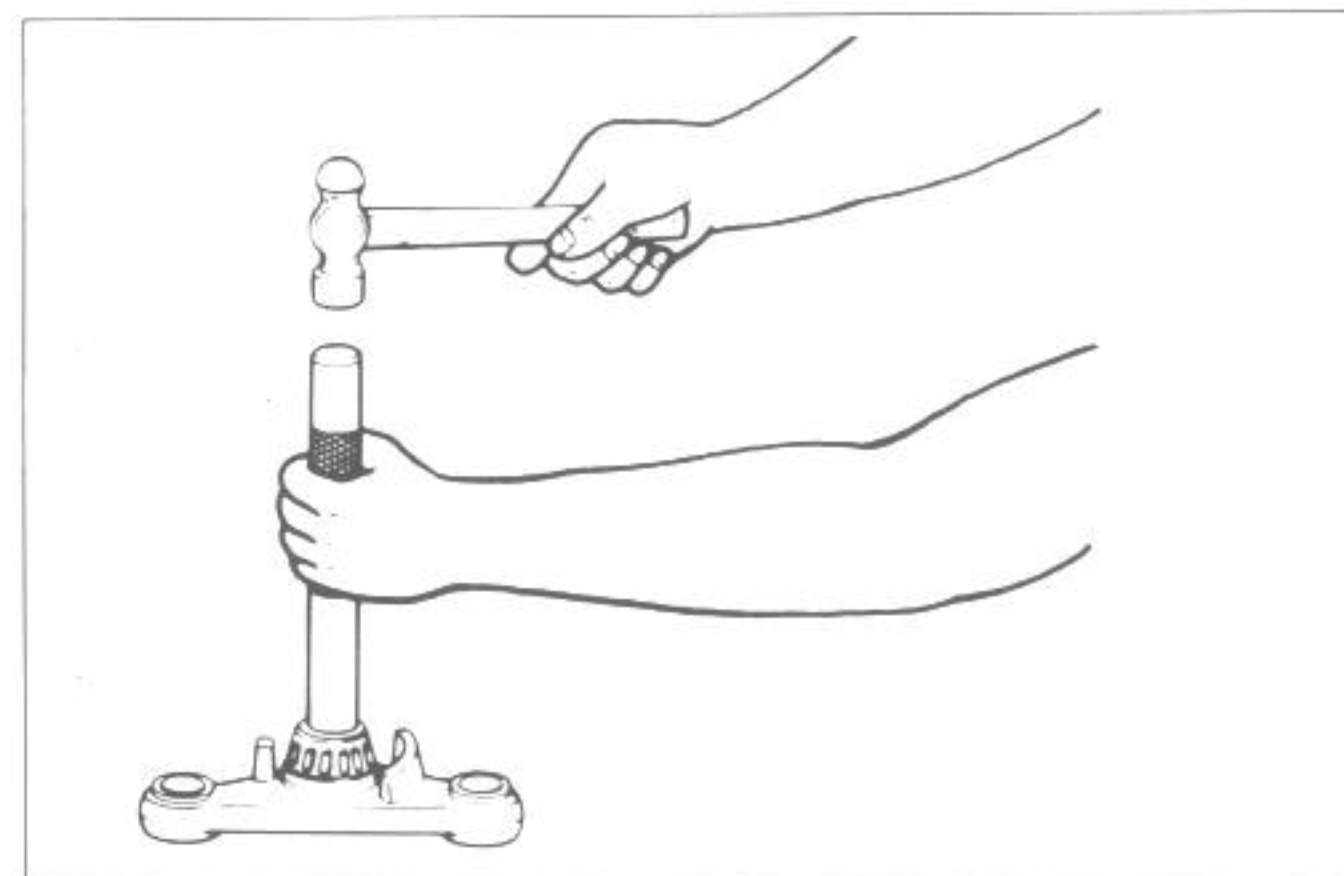

Apply grease to the upper and lower bearing races before remounting the steering stem.

99000-25010	SUZUKI super grease "A"
-------------	-------------------------

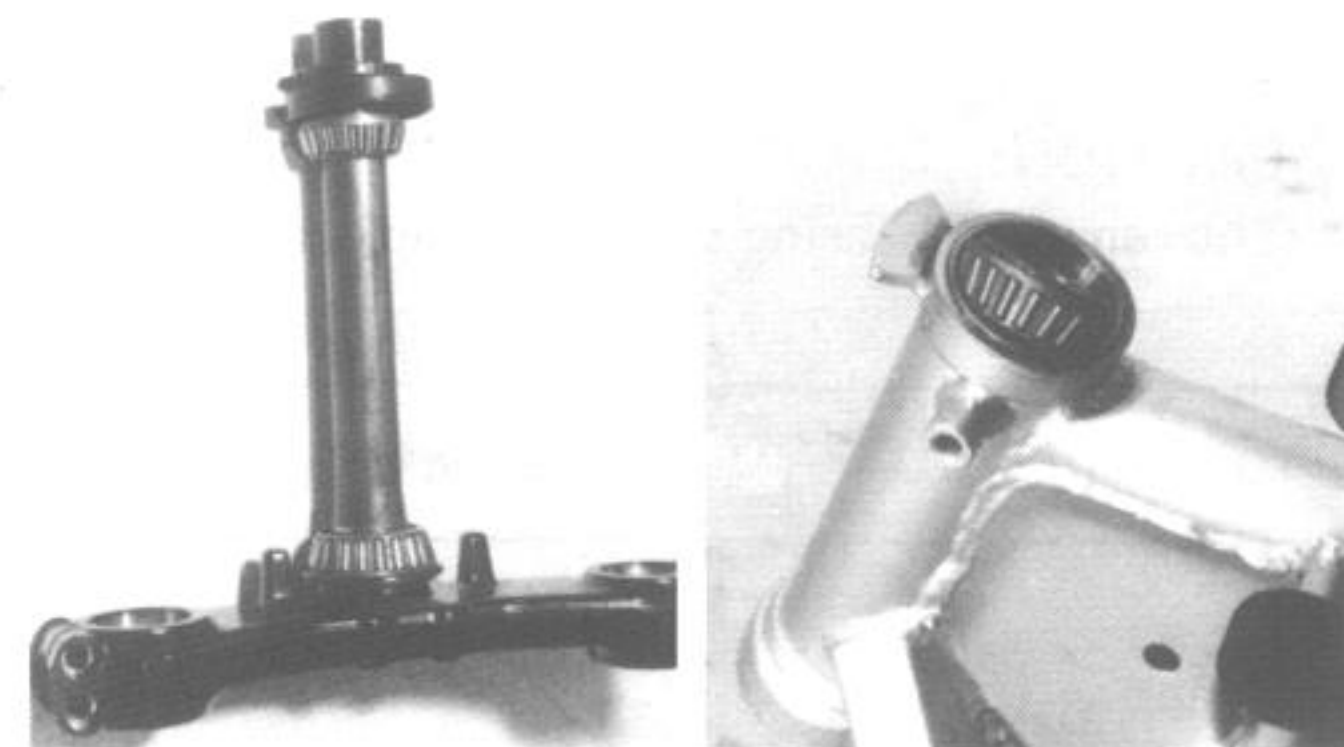

STEM NUT

Fit the dust seal to the stem nut.
Tighten the steering stem nut to 40 – 50 N·m (4.0 – 5.0 kg-m).

09940-14911	Steering stem nut wrench
-------------	--------------------------

Turn the steering stem bracket about five or six times to the left and right until it locks in position so that the taper roller bearing will be seated properly.

Turn back the stem nut by 1/4 – 1/2 turn.

NOTE:
This adjustment will vary from motorcycle to motorcycle.

Steering stem head bolt should be tightened to the specified torque.

Tightening torque	20 – 30 N·m (2.0 – 3.0 kg-m)
-------------------	---------------------------------

CAUTION:
After performing the adjustment and installing the steering stem upper bracket, “rock” the front wheel assembly forward and back to ensure that there is no play and that the procedure was accomplished correctly. Finally check to be sure that the steering stem moves freely from left to right with own weight. If play or stiffness is noticeable, re-adjust the steering stem nut.

- Tighten the handlebars clamp bolts and nuts to the specification.

Tightening torque (Bolt)	50 – 60 N·m (5.0 – 6.0 kg-m)
(Nut)	20 – 30 N·m (2.0 – 3.0 kg-m)

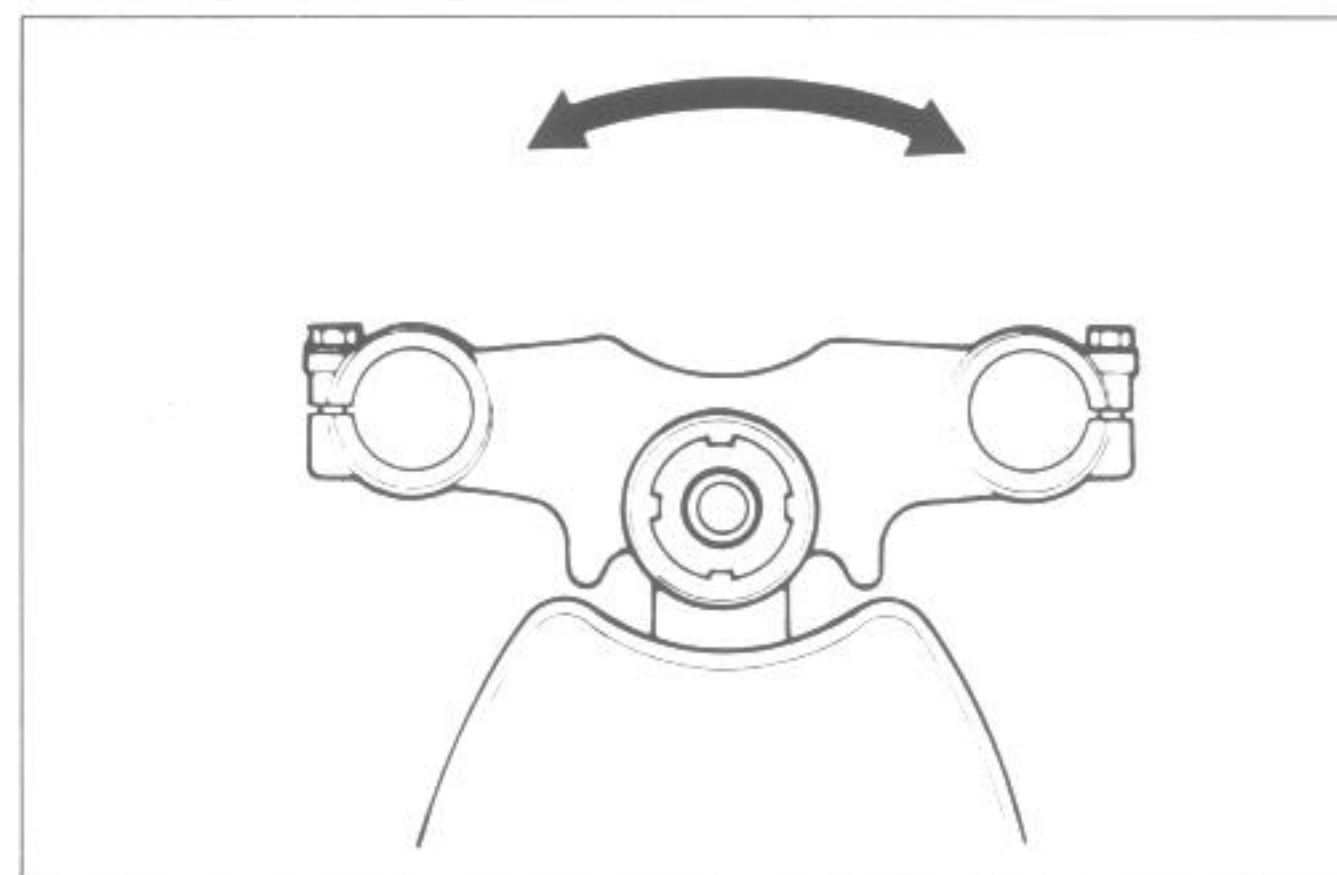
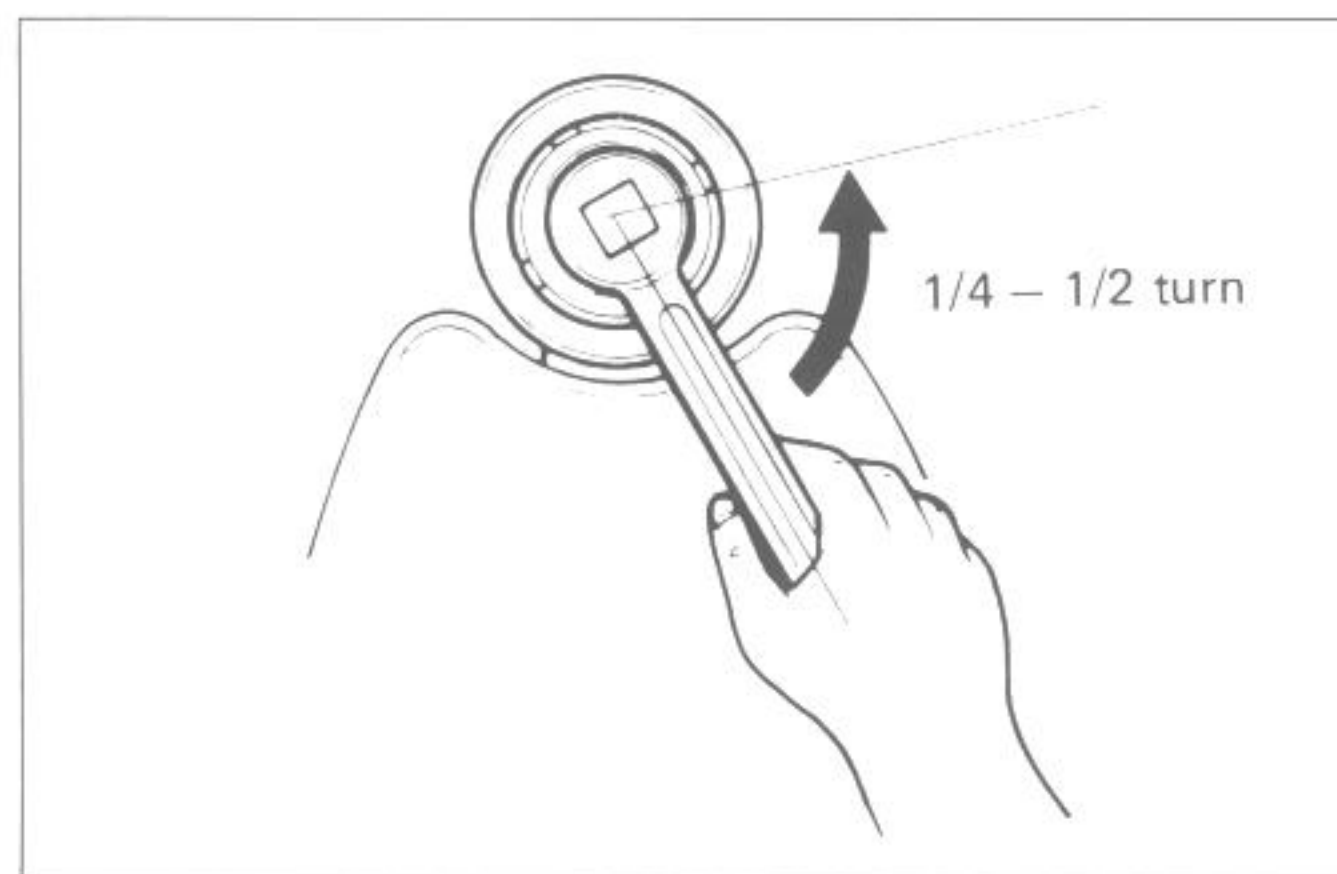
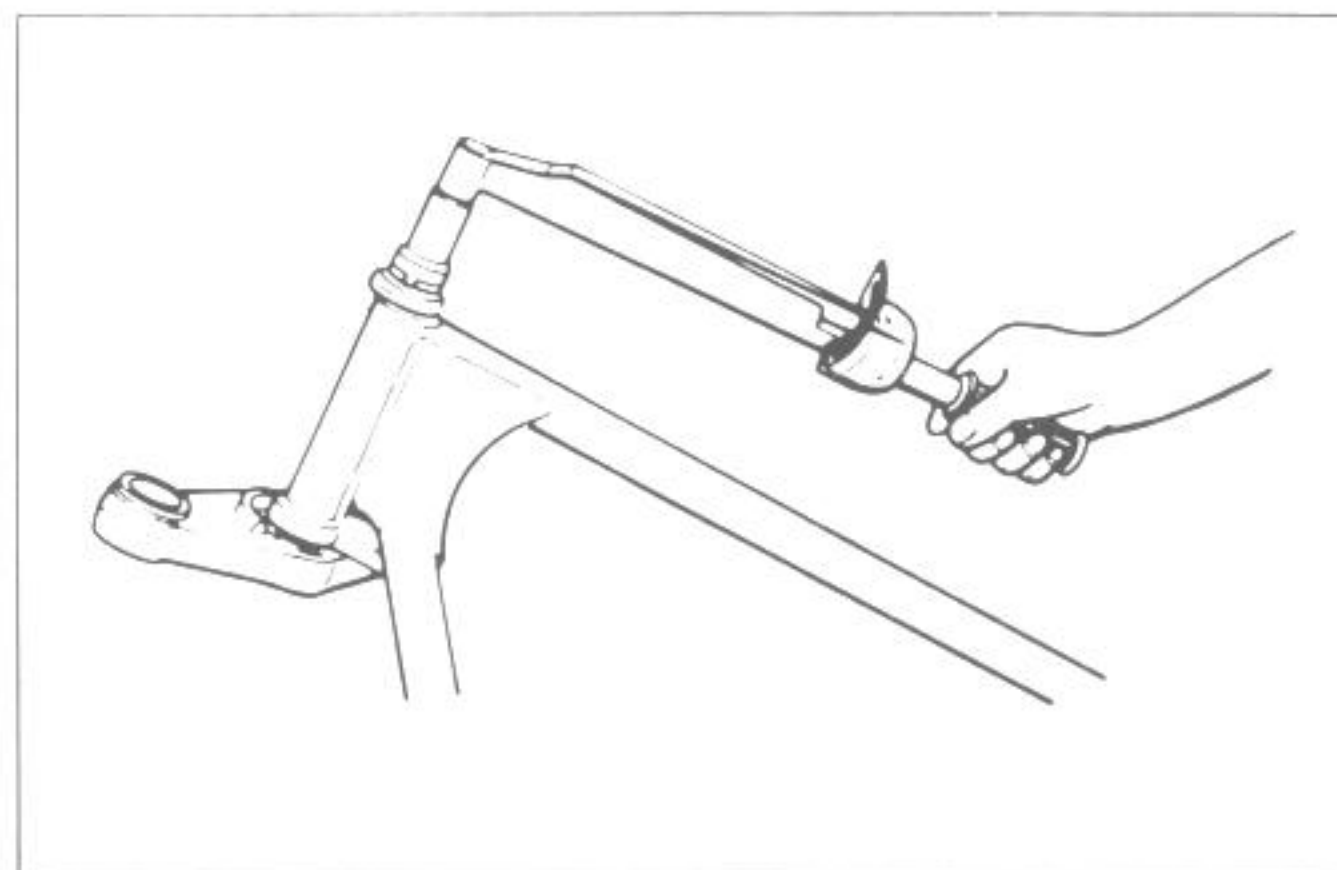

REAR BRAKE

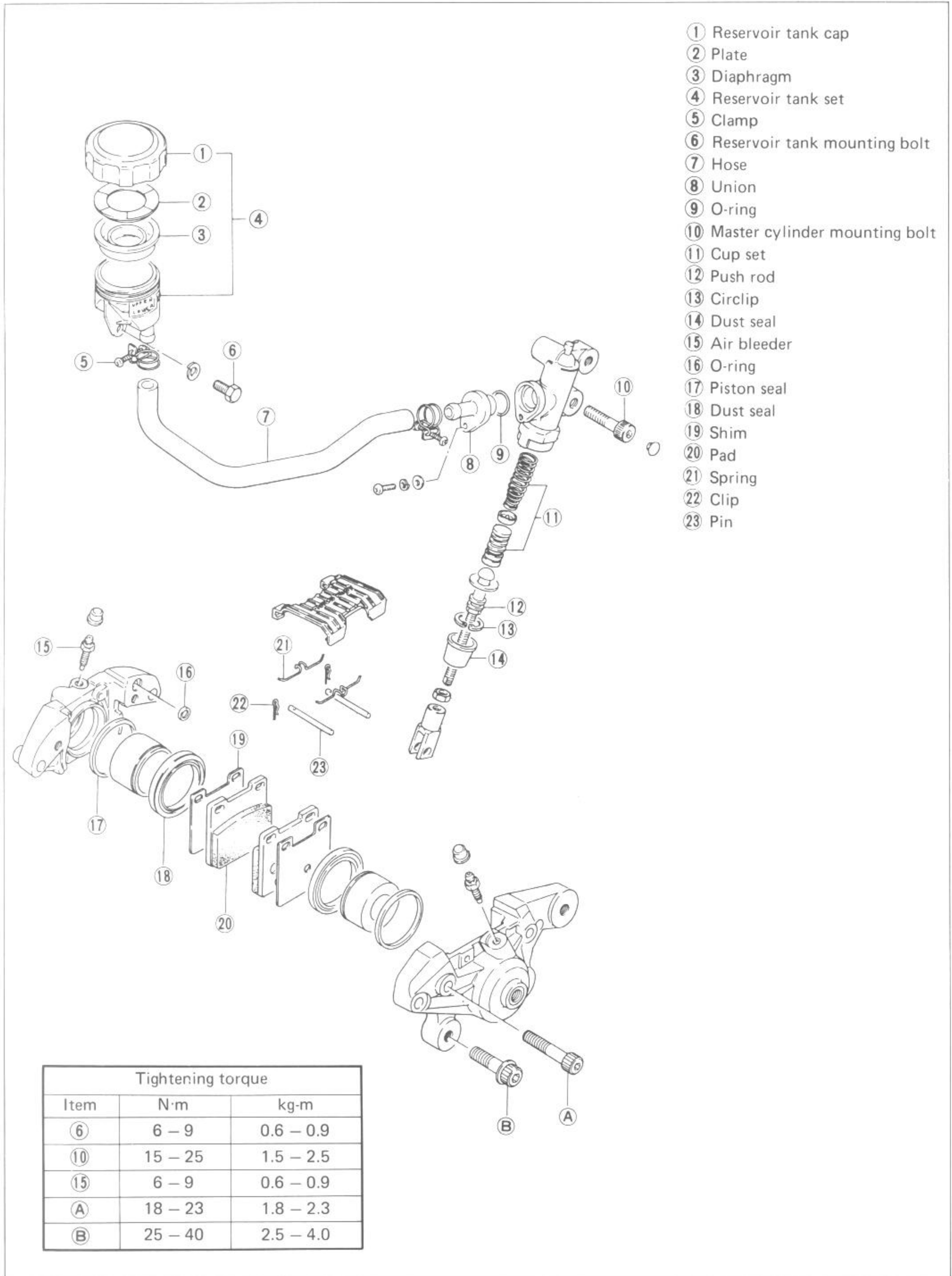

- ① Reservoir tank cap
- ② Plate
- ③ Diaphragm
- ④ Reservoir tank set
- ⑤ Clamp
- ⑥ Reservoir tank mounting bolt
- ⑦ Hose
- ⑧ Union
- ⑨ O-ring
- ⑩ Master cylinder mounting bolt
- ⑪ Cup set
- ⑫ Push rod
- ⑬ Circlip
- ⑭ Dust seal
- ⑮ Air bleeder
- ⑯ O-ring
- ⑰ Piston seal
- ⑱ Dust seal
- ⑲ Shim
- ⑳ Pad
- ㉑ Spring
- ㉒ Clip
- ㉓ Pin

Tightening torque		
Item	N·m	kg-m
⑥	6 - 9	0.6 - 0.9
⑩	15 - 25	1.5 - 2.5
⑮	6 - 9	0.6 - 0.9
A	18 - 23	1.8 - 2.3
B	25 - 40	2.5 - 4.0

BRAKE PAD REPLACEMENT

- Remove dust cover.
- Pull off clips.
- Pull off brake pad hold pins.
- Take off brake pads with pad shims.

NOTE:

Do not operate the brake pedal while taking off the brake pads.

CAUTION:

Replace the brake pad with a set, otherwise braking performance will be adversely affected.

CAUTION:

Fit the brake pad shims to the brake pad so that the shims are positioned as shown in the figure.

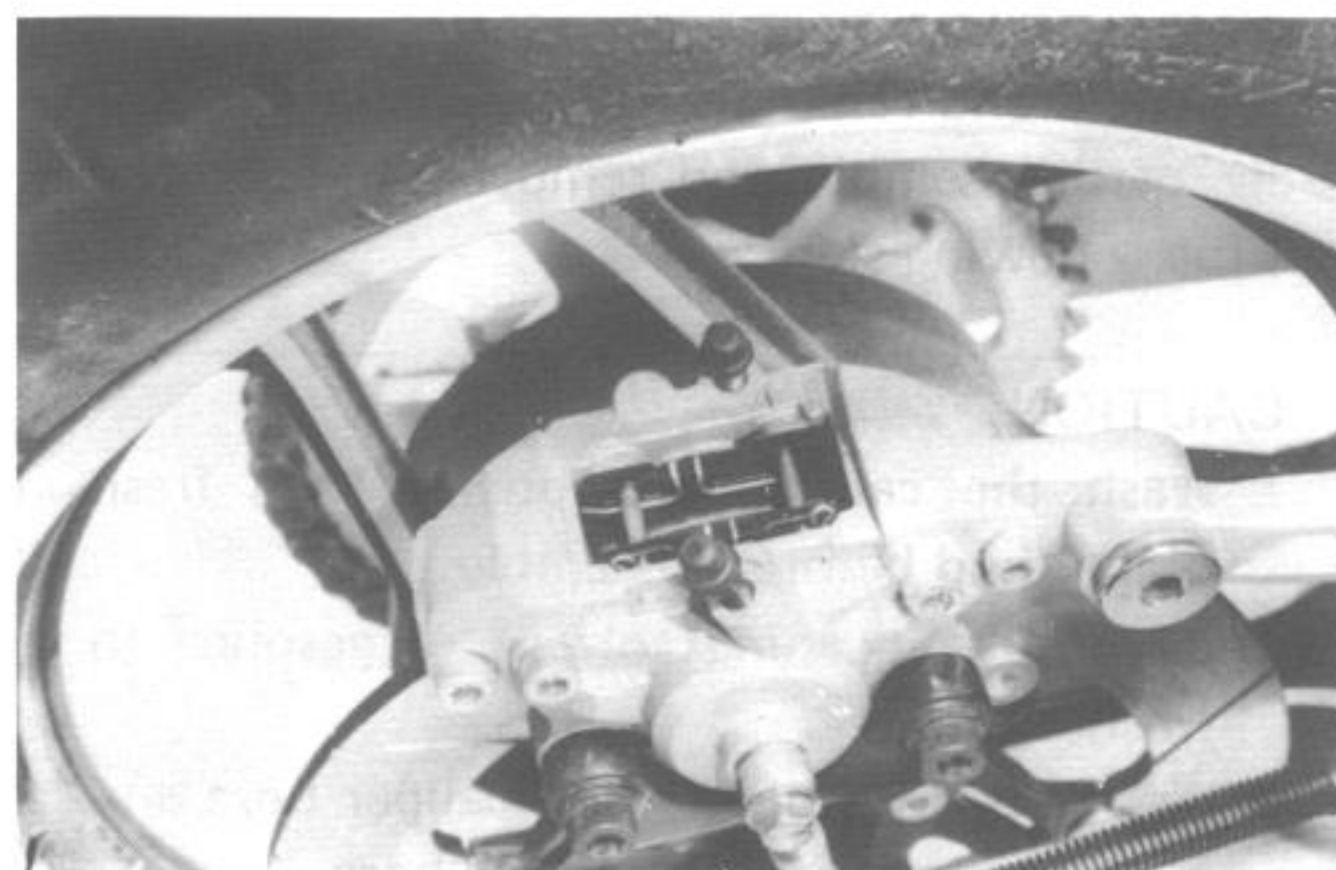

CALIPER REMOVAL AND DISASSEMBLY

- Remove the union bolt and catch the brake fluid in a suitable receptacle.
- Pull out the cotter pin and remove the torque link bolt and nut.
- Remove the caliper mounting bolts and take off the caliper.

NOTE:

Slightly loosen the caliper housing bolts to facilitate later disassembly before loosening the caliper mounting bolts.

- For disassembling and inspecting calipers take the same procedures as the front brake servicing. (Refer to page 6-9).

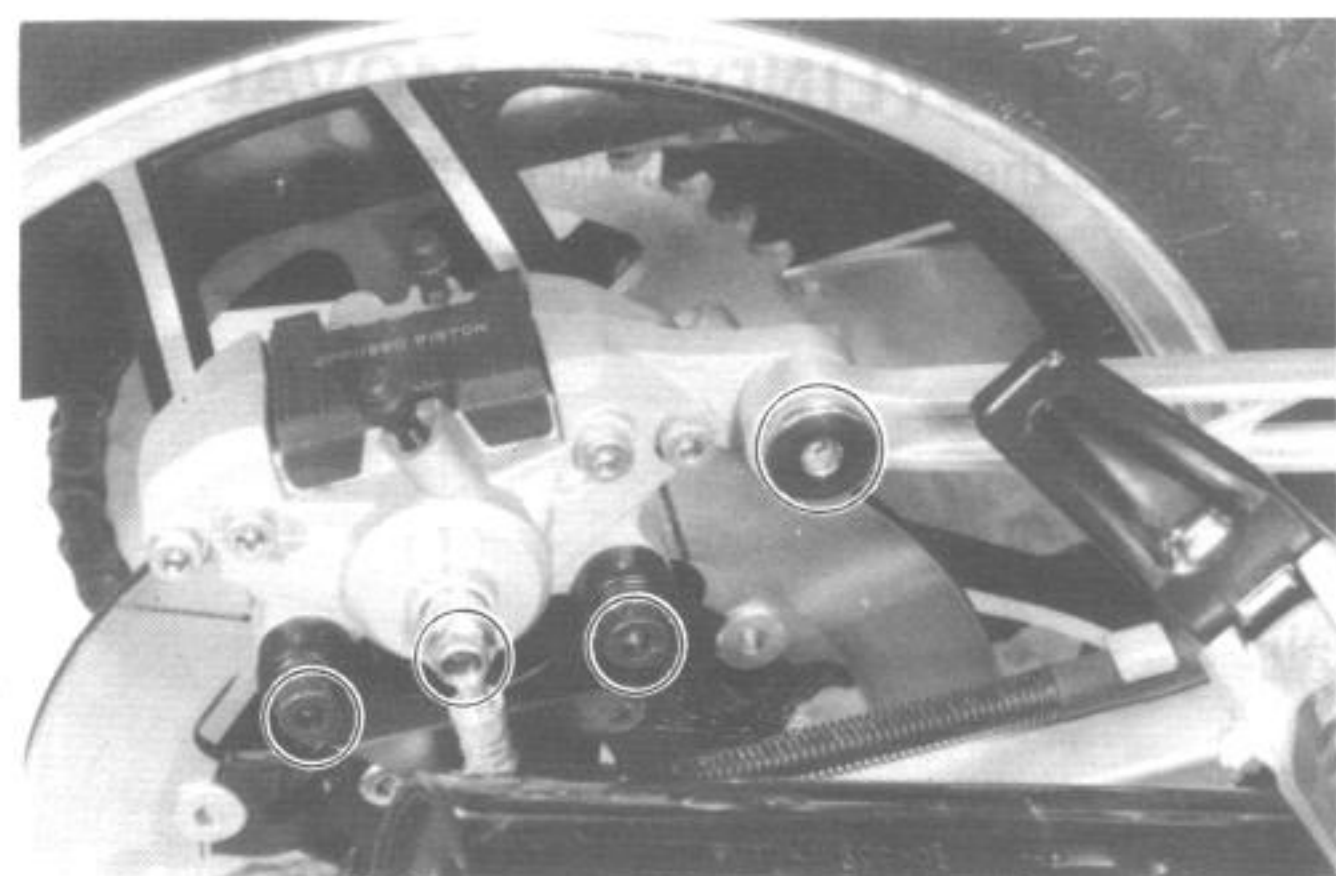

- Remove the brake pedal bolt and take off the brake pedal.
- Remove the muffler and footrest mounting bracket.

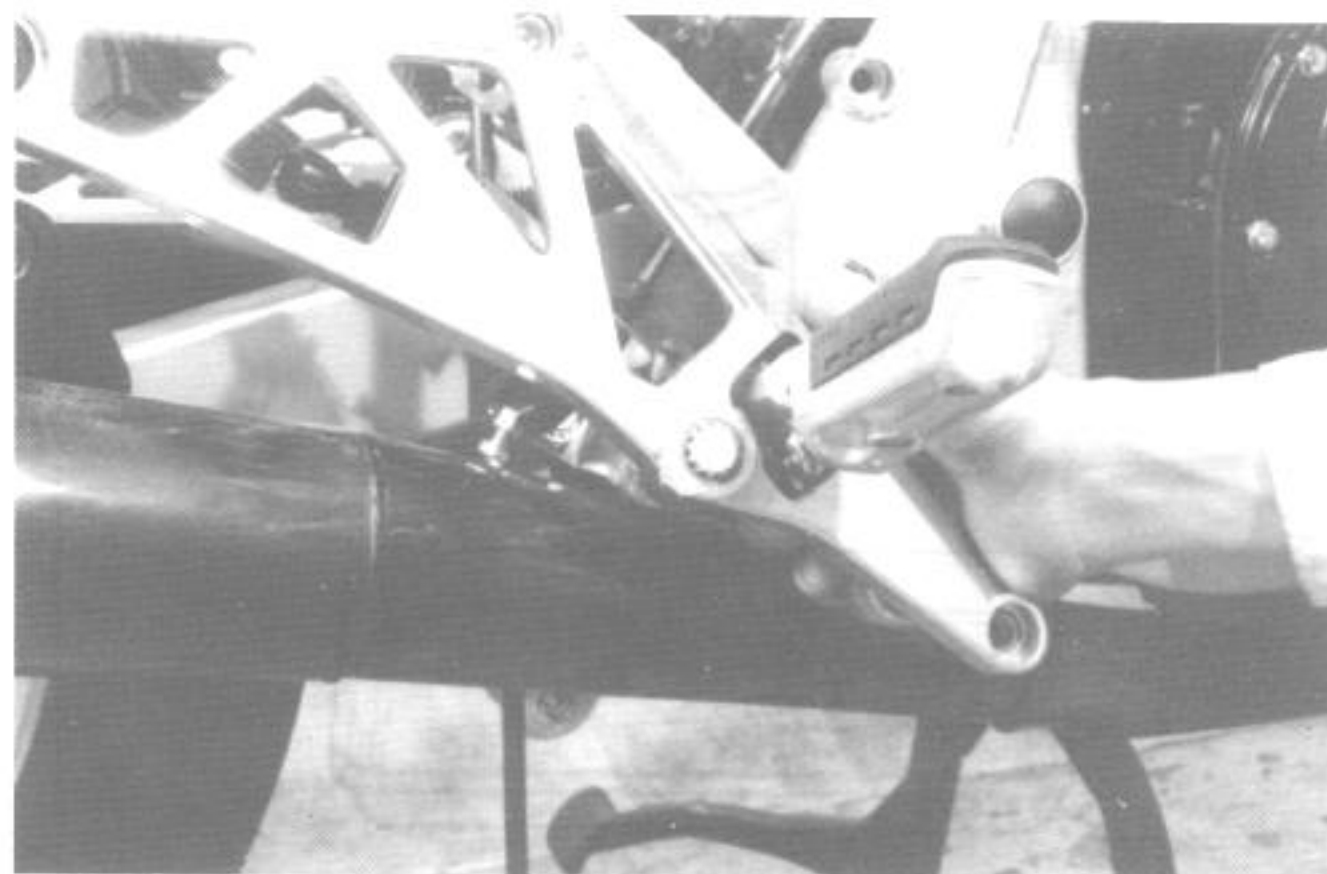

- Place a rag underneath the union bolt on the master cylinder to catch spilled drops of brake fluid. Unscrew the union bolt and disconnect the brake hose from master cylinder.

**CAUTION:**

Completely wipe off any brake fluid adhering to any part of motorcycle. The fluid reacts chemically with paint, plastics, rubber materials, etc.

- Pull out the cotter pin ① and take off the brake pedal shaft from the master cylinder.

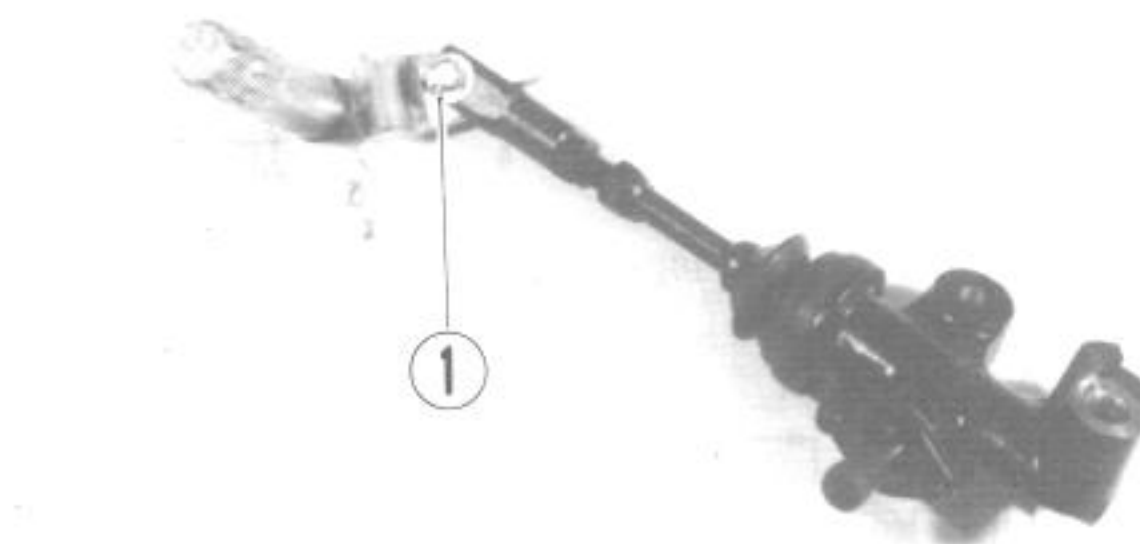

- Remove the circlip, rod, piston, primary cup and spring by using the special tool.

09900-06105

Snap ring pliers



- Draw out the push rod, piston, cup and spring.



- Remove the union and O-ring from the master cylinder body.

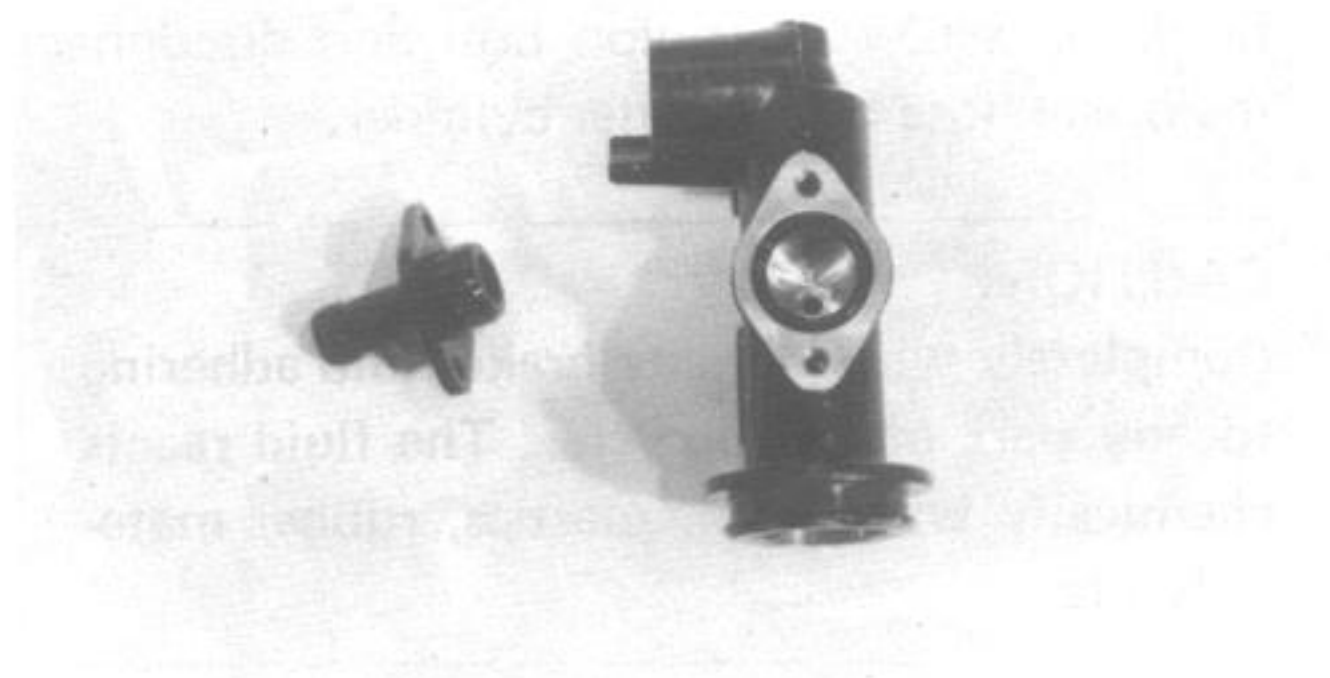

INSPECTION

CYLINDER

Inspect the cylinder bore wall for any scratches or other damage.

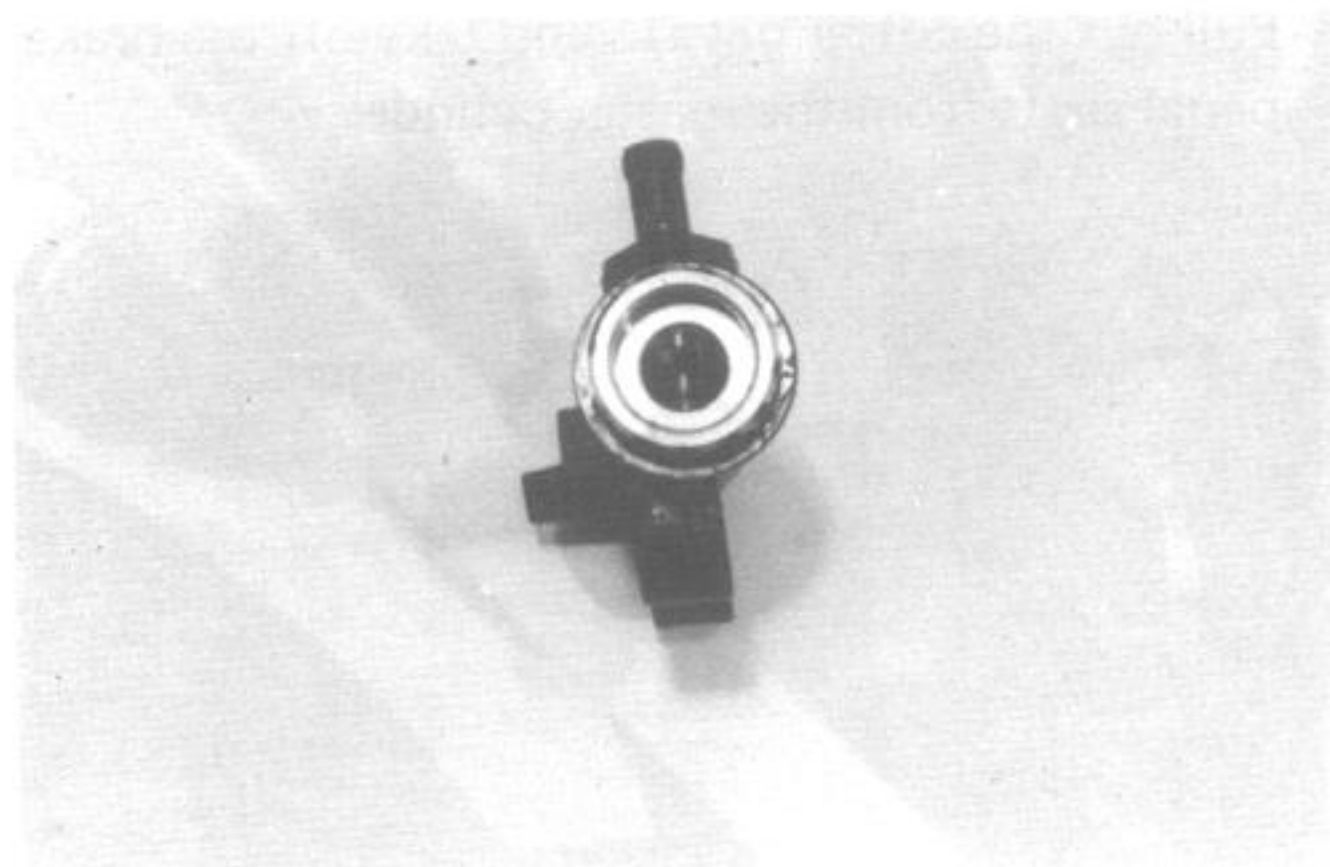

PISTON AND CUP SET

Inspect the piston surface for scratches or other damage.

Inspect the cup set and each rubber part for damage.

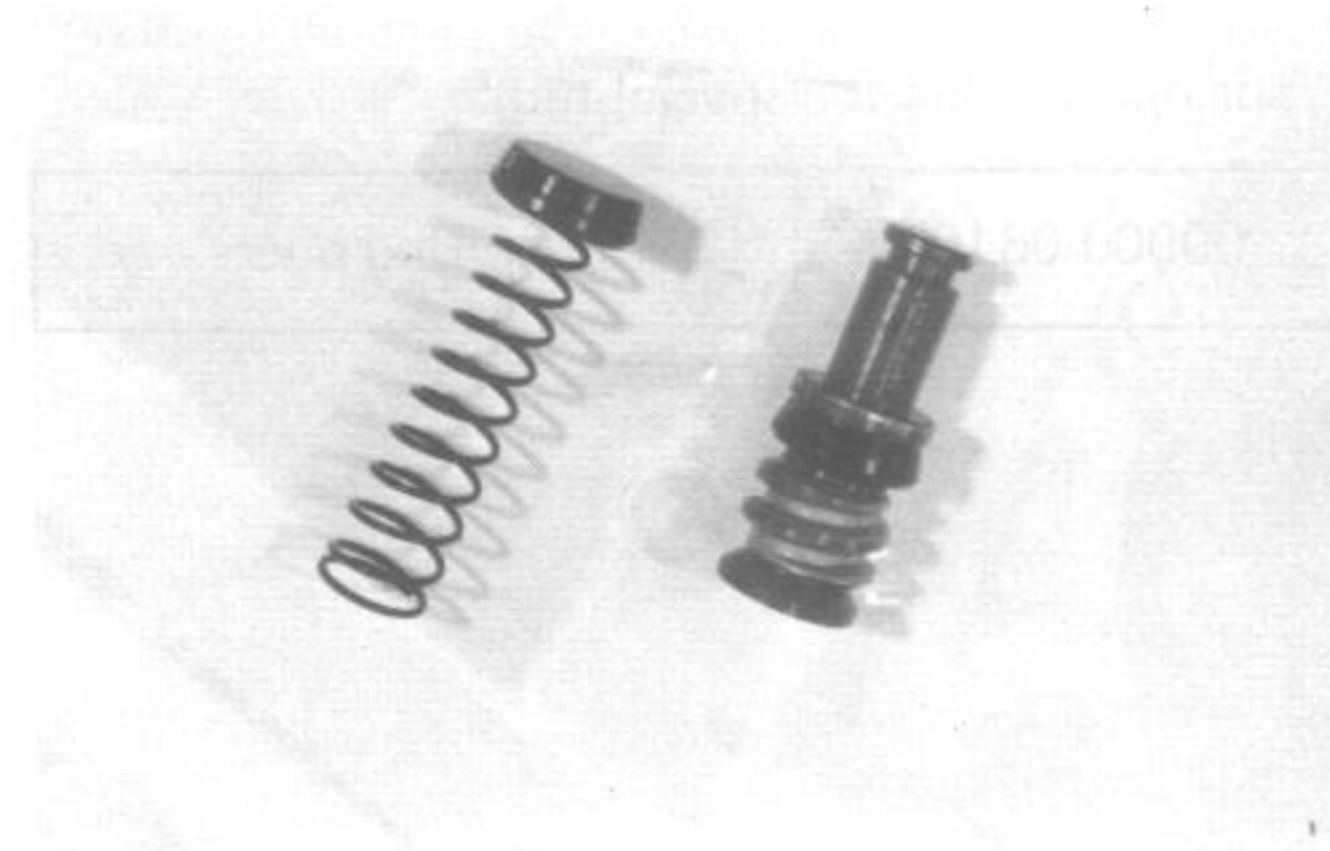

DISC PLATE

Refer to page 6-10.

REASSEMBLY

Reassemble and remount the master cylinder in the reverse order of disassembly and removal, and also carry out the following steps:

CAUTION:

Wash the master cylinder components with fresh brake fluid before reassembly. Never use cleaning solvent or gasoline to wash them. Apply brake fluid to the cylinder bore and all the internals to be inserted into the bore.

CAUTION:

Bleed the air after reassembling master cylinder. (See page 2-20).
Adjust the rear brake light switch and brake pedal height after installation. (See page 2-19).

REAR BRAKE PEDAL RETURN SPRINGS

When installing the brake pedal shaft to the muffler and footrest mounting bracket, install the two springs properly as shown in the illustration.

Apply grease to the brake pedal shaft hole.

REAR BRAKE PEDAL

When installing the rear brake pedal, align the brake pedal groove with punched mark provided on the end face of the brake pedal rod arm.

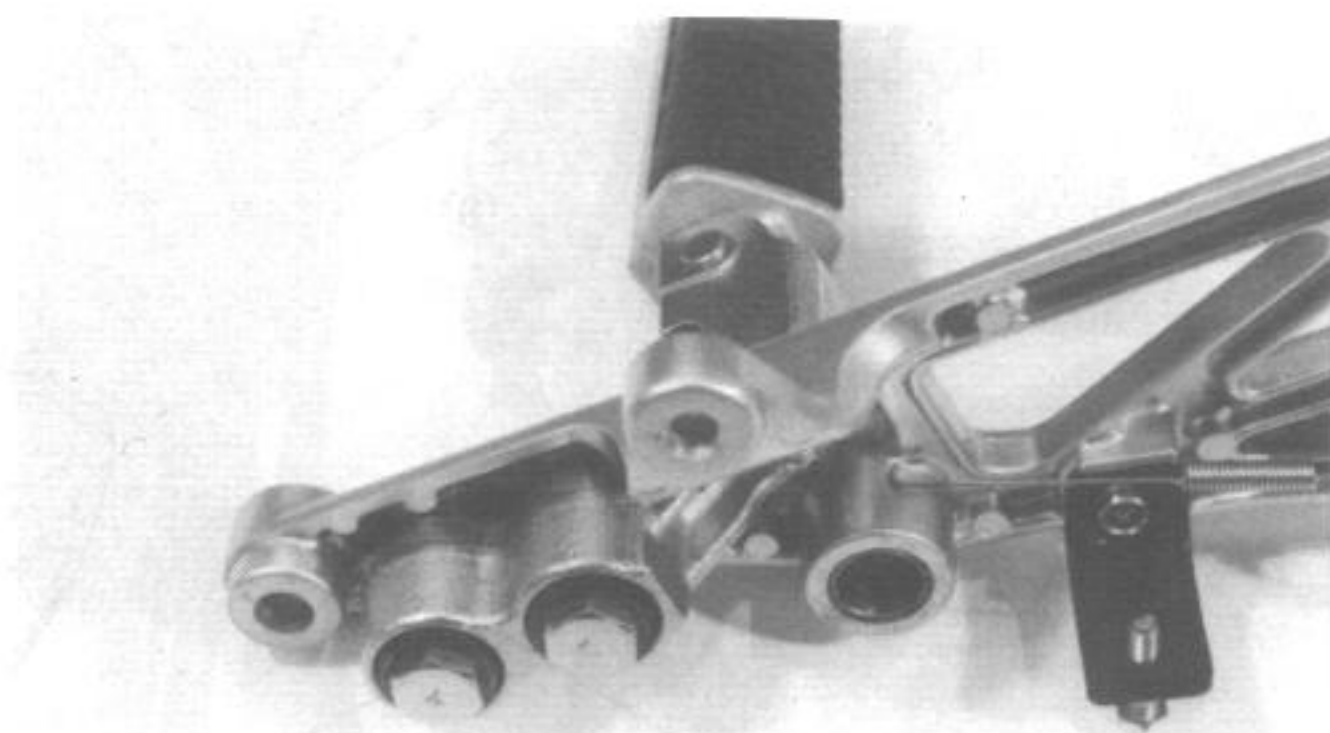
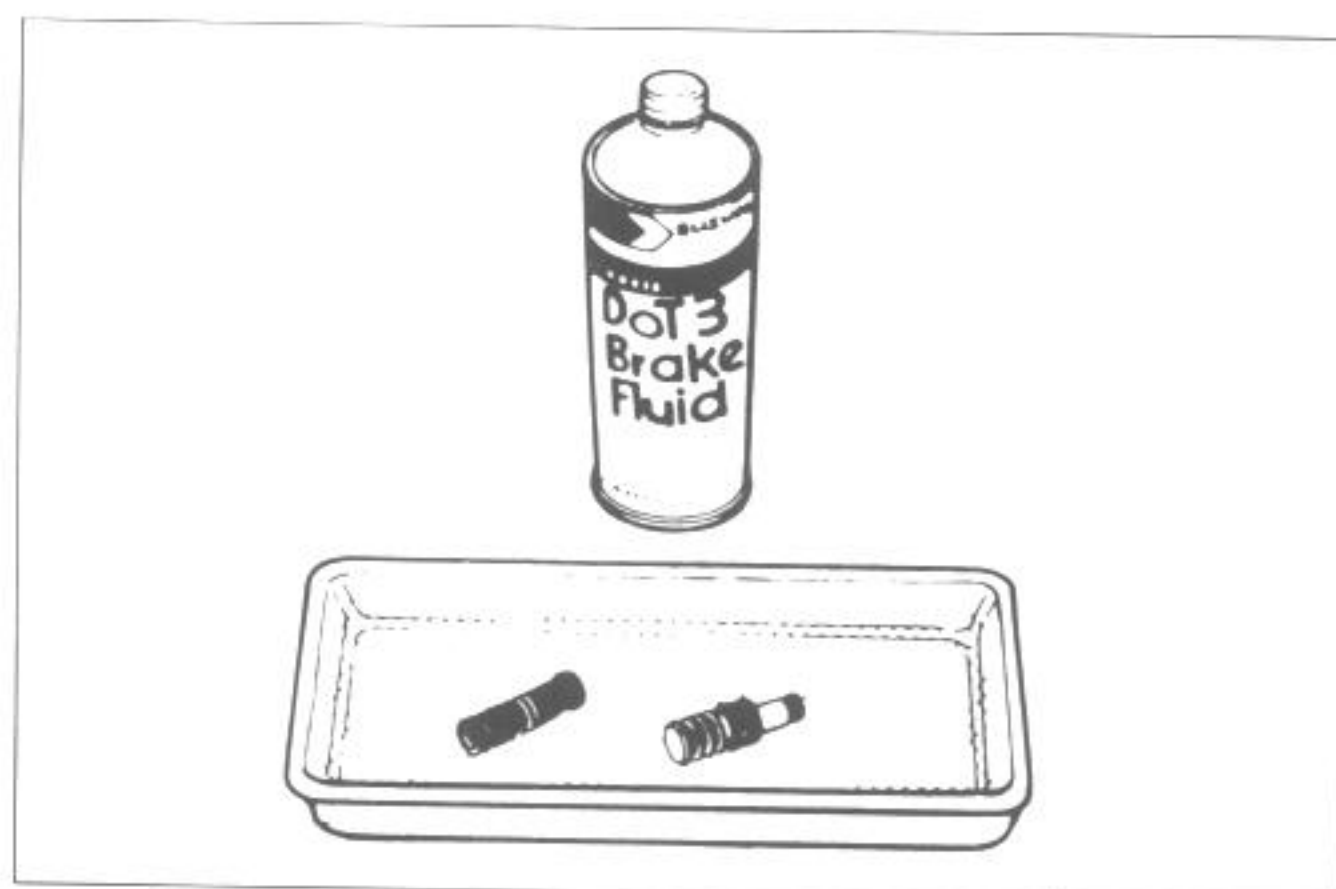
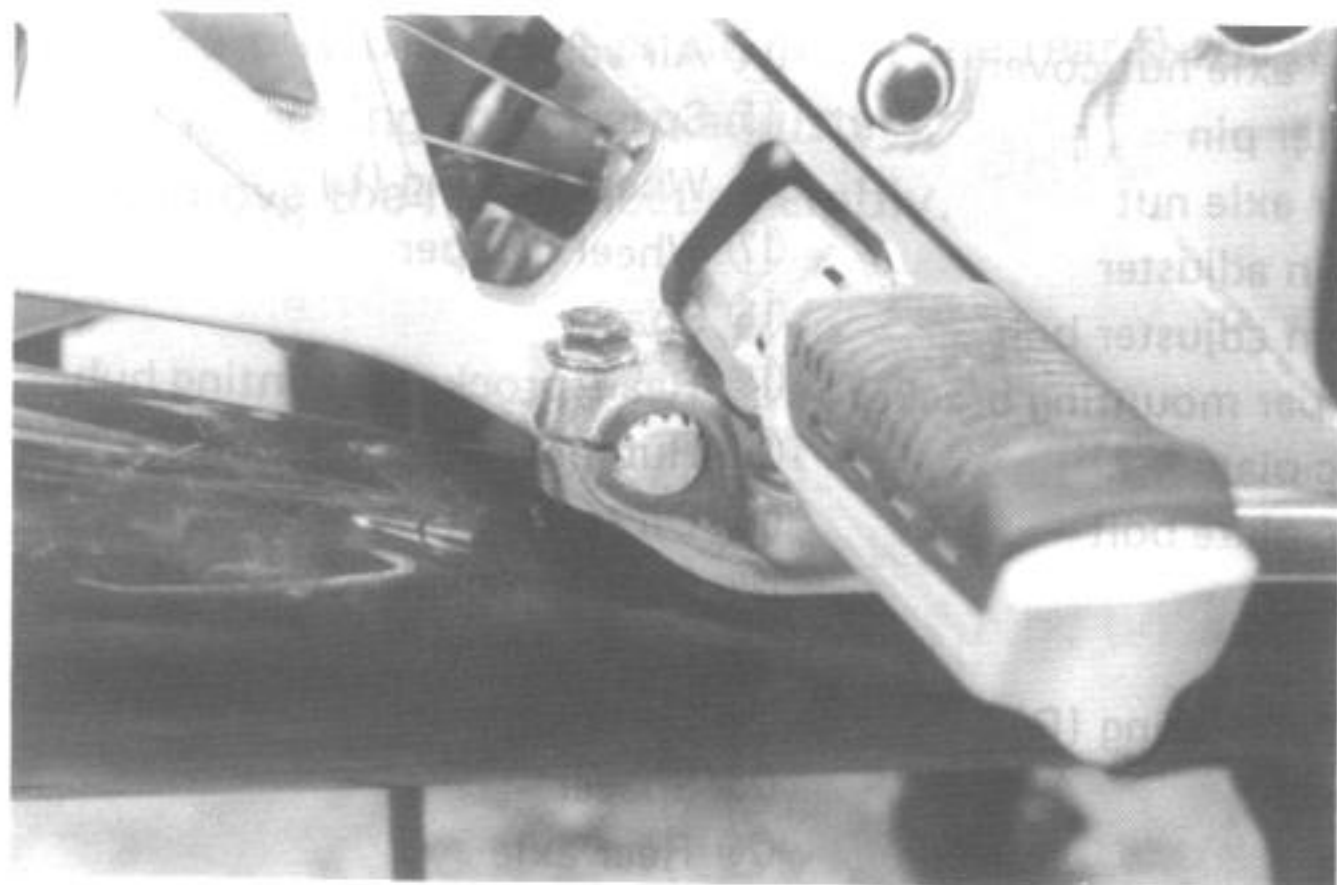

Rear brake pedal spring installation

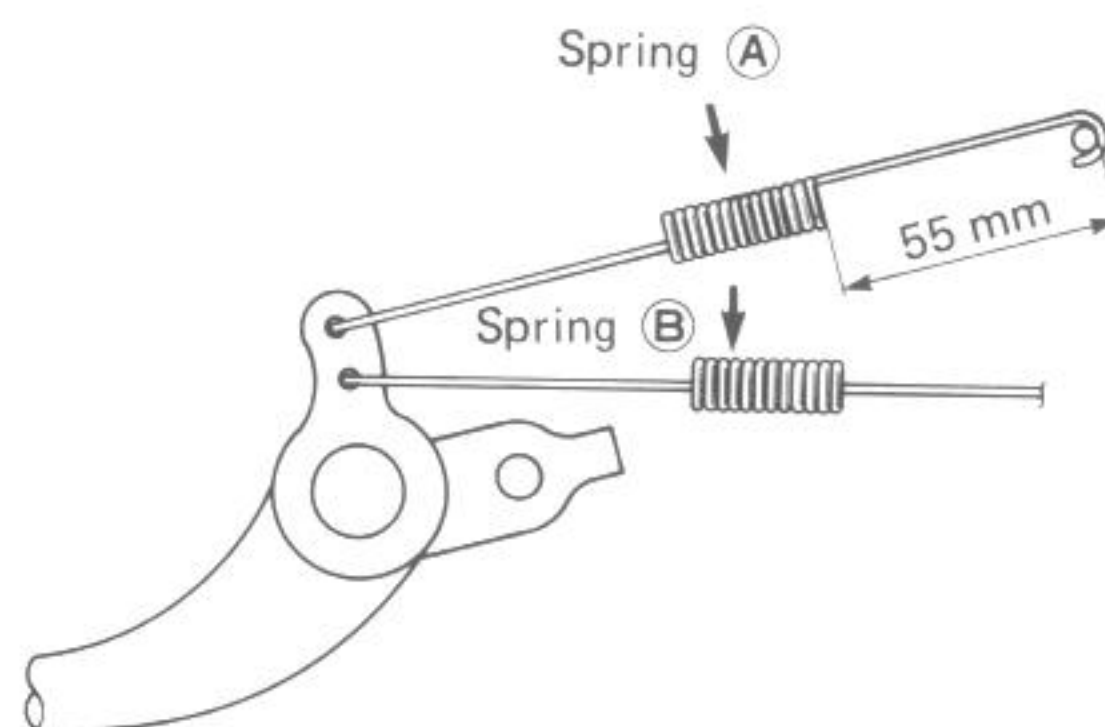
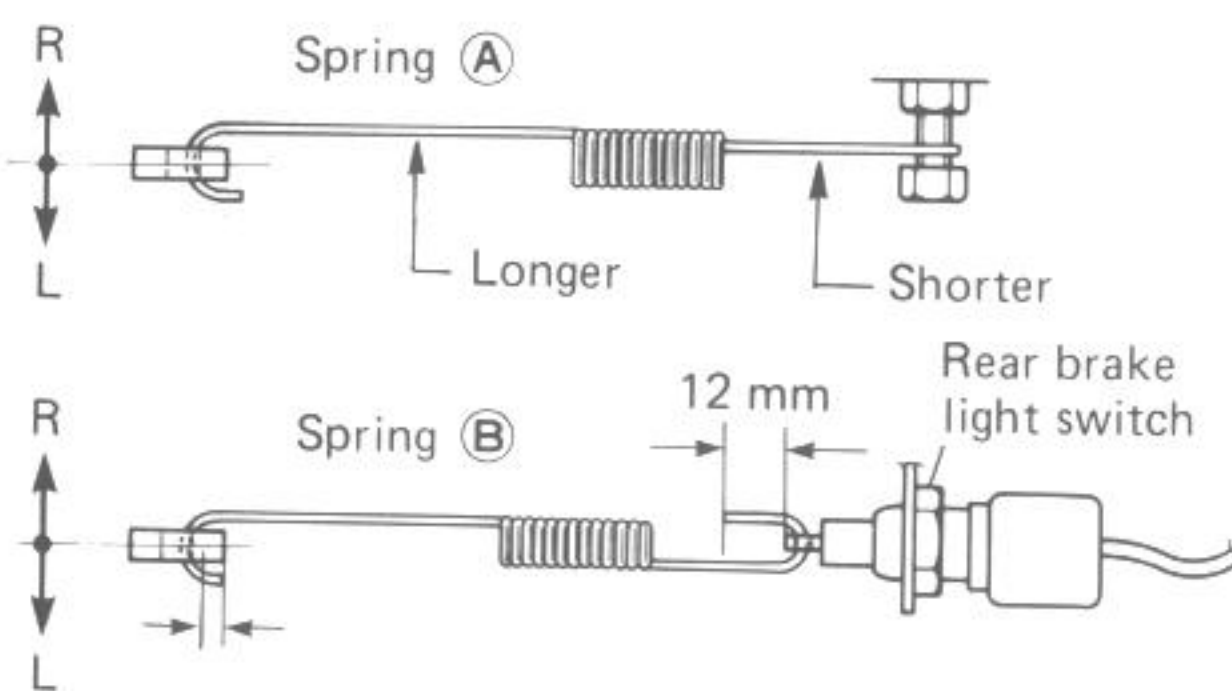

REAR WHEEL

CONSTRUCTION

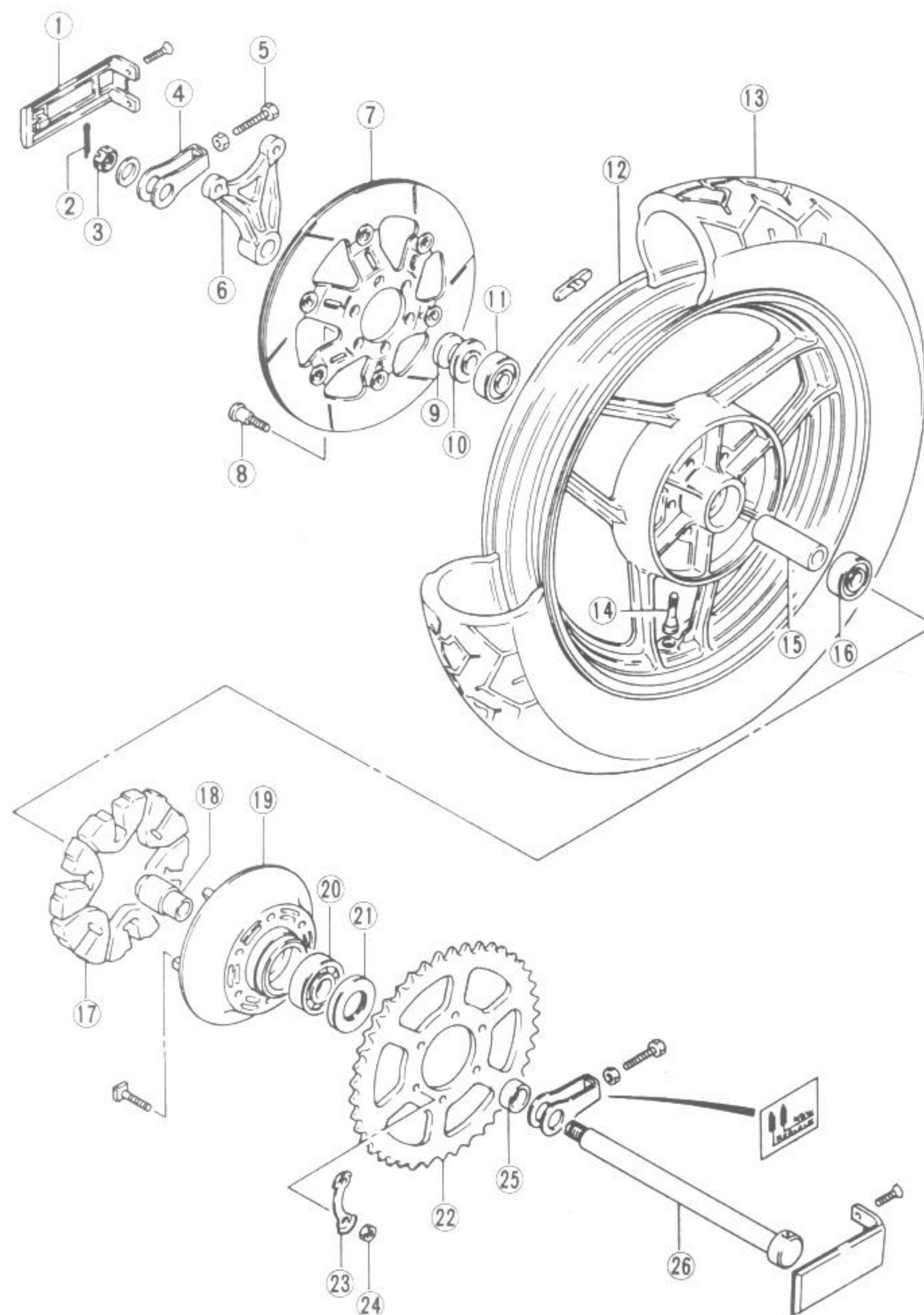

Tightening torque		
Item	N·m	kg·m
③	85 – 115	8.5 – 11.5
⑧	15 – 25	1.5 – 2.5
⑳	25 – 40	2.5 – 4.0

- | | |
|----------------------------|------------------------------|
| ① Rear axle nut cover | ⑭ Air valve |
| ② Cotter pin | ⑮ Spacer |
| ③ Rear axle nut | ⑯ Wheel bearing (L) |
| ④ Chain adjuster | ⑰ Wheel damper |
| ⑤ Chain adjuster bolt | ⑱ Spacer |
| ⑥ Caliper mounting bracket | ⑲ Rear sprocket mounting hub |
| ⑦ Disc plate | ⑳ Hub bearing |
| ⑧ Disc plate bolt | ㉑ Oil seal |
| ⑨ Spacer | ㉒ Rear sprocket |
| ⑩ Oil seal | ㉓ Lock washer |
| ⑪ Wheel bearing (R) | ㉔ Sprocket nut |
| ⑫ Wheel | ㉕ Spacer |
| ⑬ Tire | ㉖ Rear axle |

REMOVAL AND DISASSEMBLY

- Remove the two bolts and take off the chain case.
- Remove the caliper mounting bolts and torque link bolt.

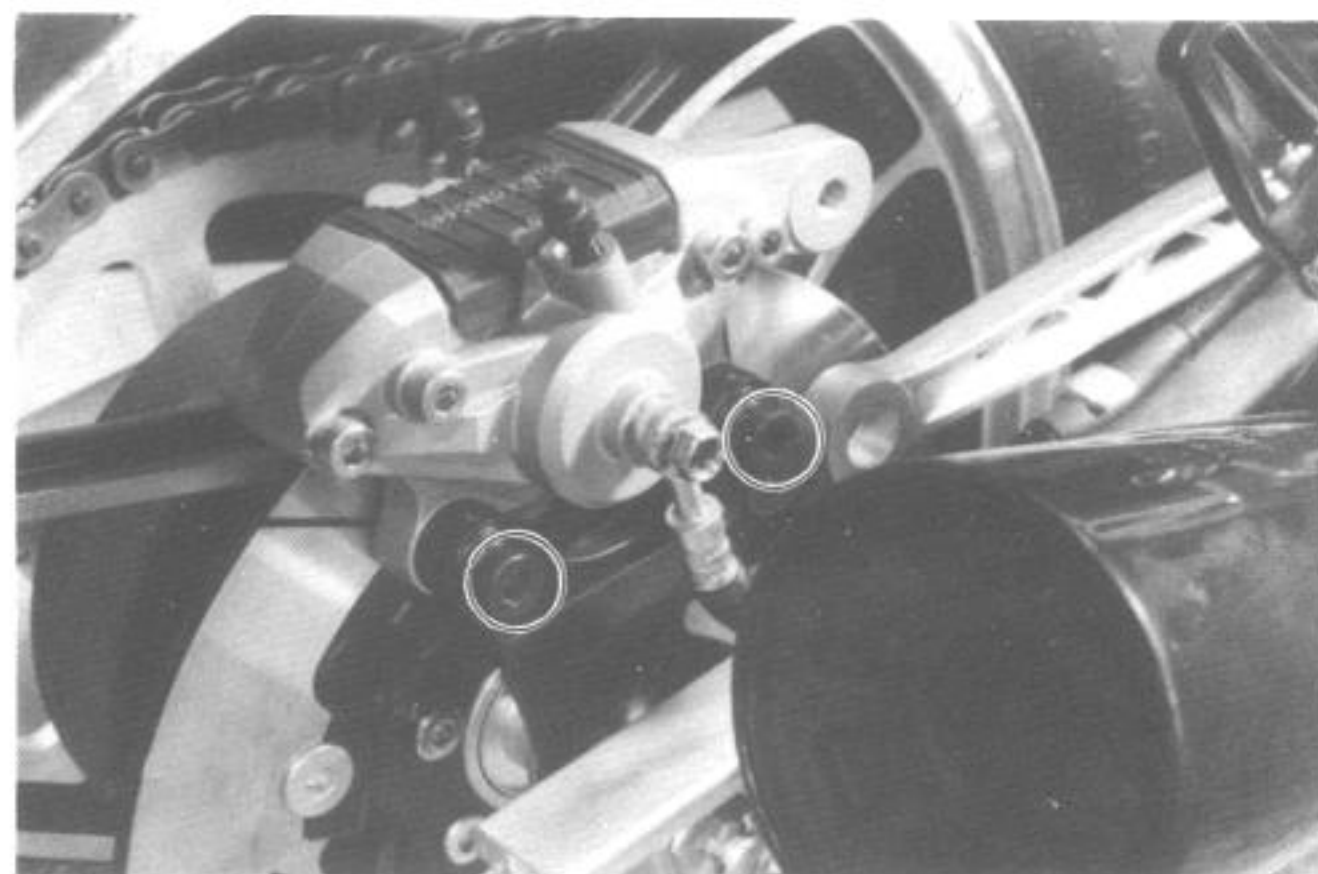

- Remove the axle shaft cover.

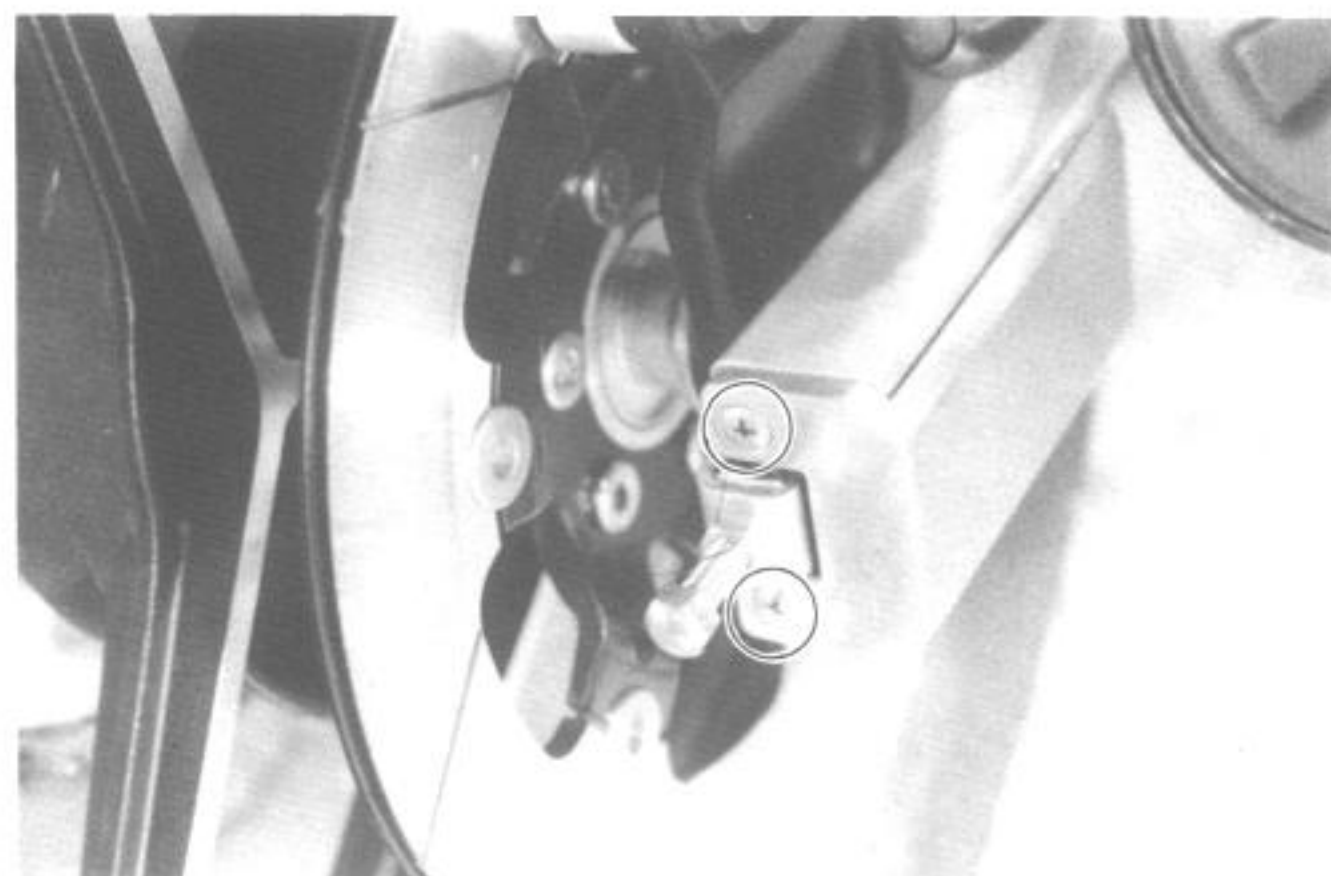

- Take off the cotter pin and remove the axle nut.
- Draw out the axle shaft.



- Take out the drive chain from the rear sprocket by loosening the chain adjusters.
- Remove the rear wheel assembly.

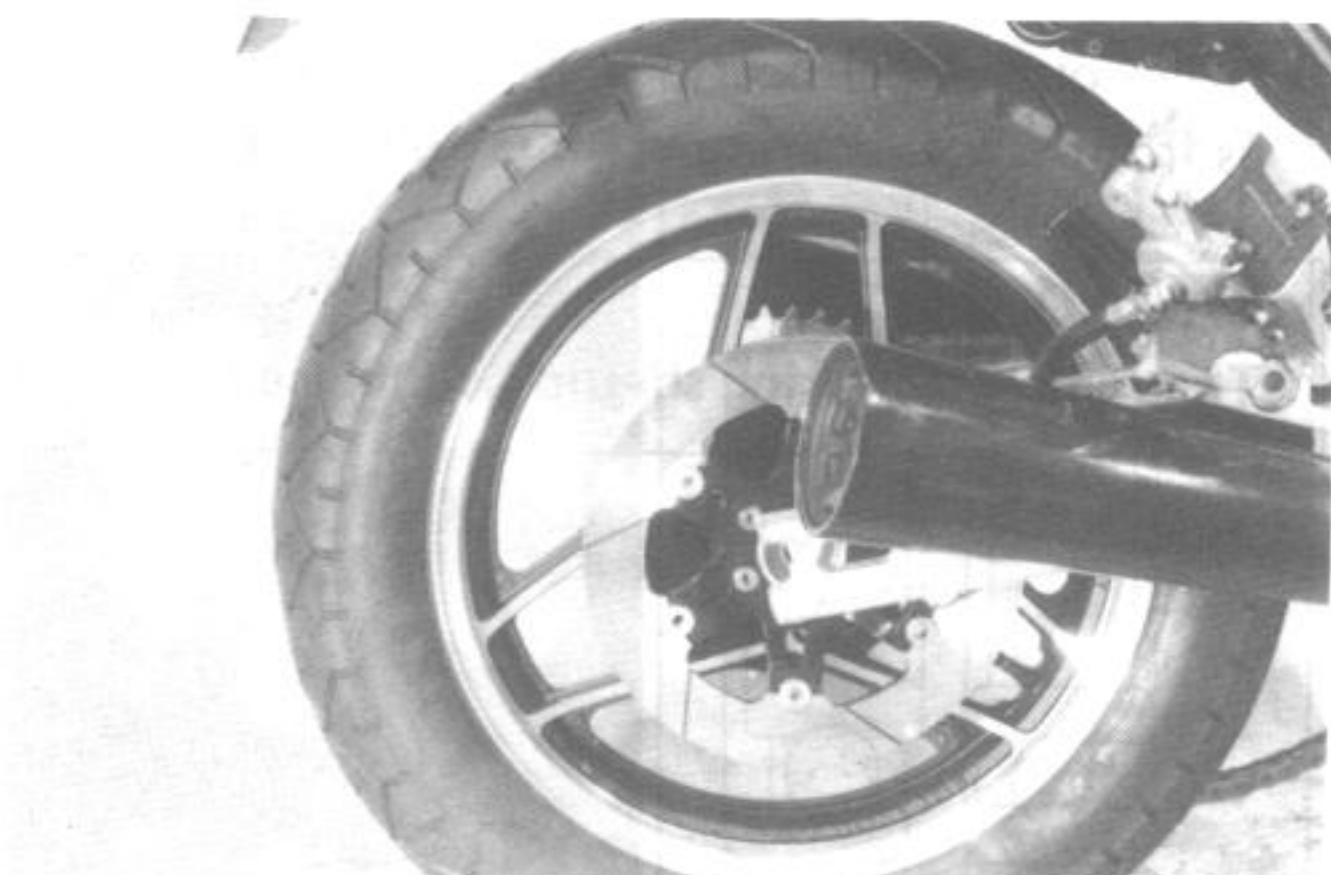

- Draw out the rear sprocket mounting drum from the wheel.



- Remove the six cushions.

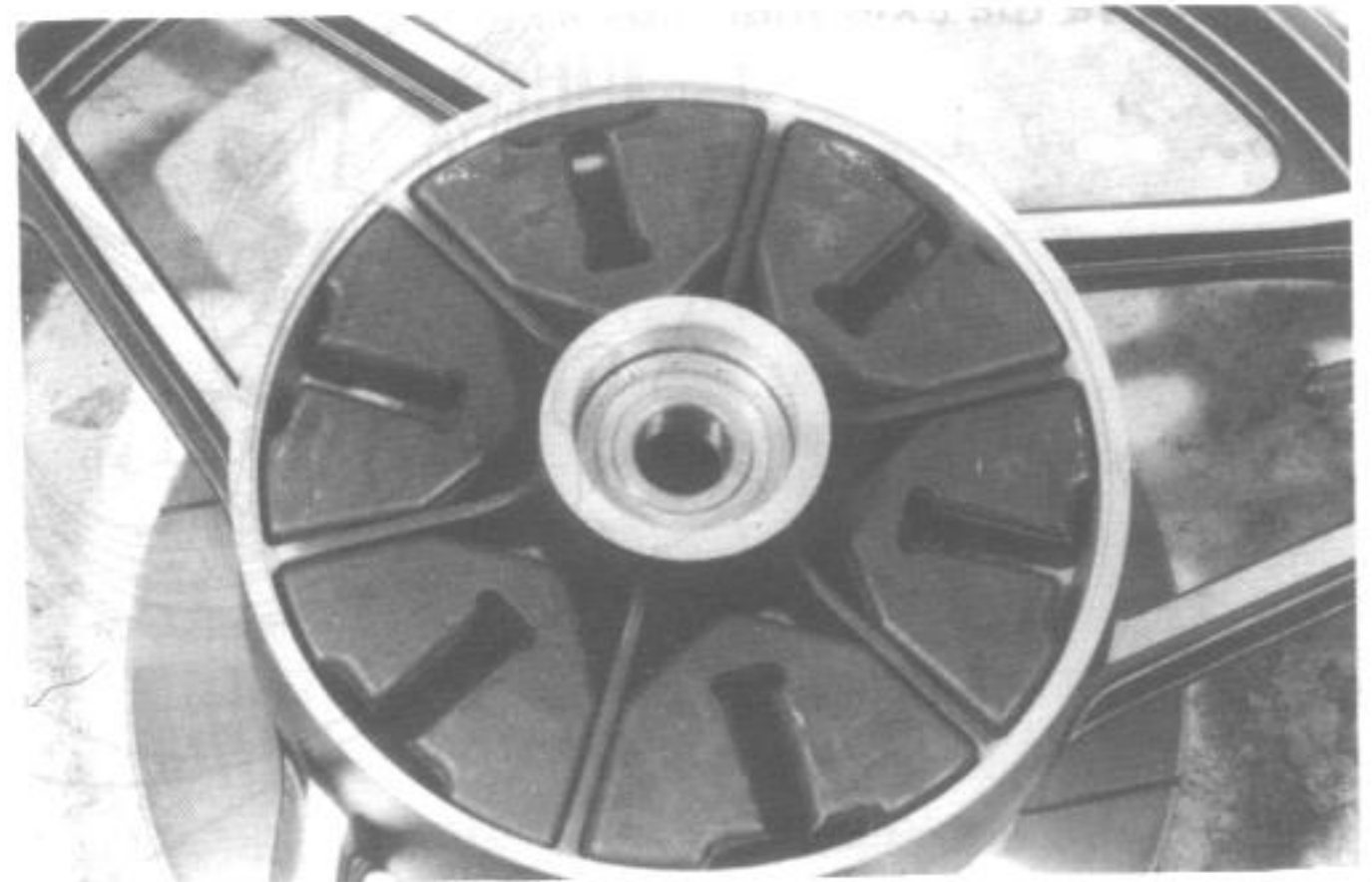

- Remove the six bolts and separate the disc from wheel.

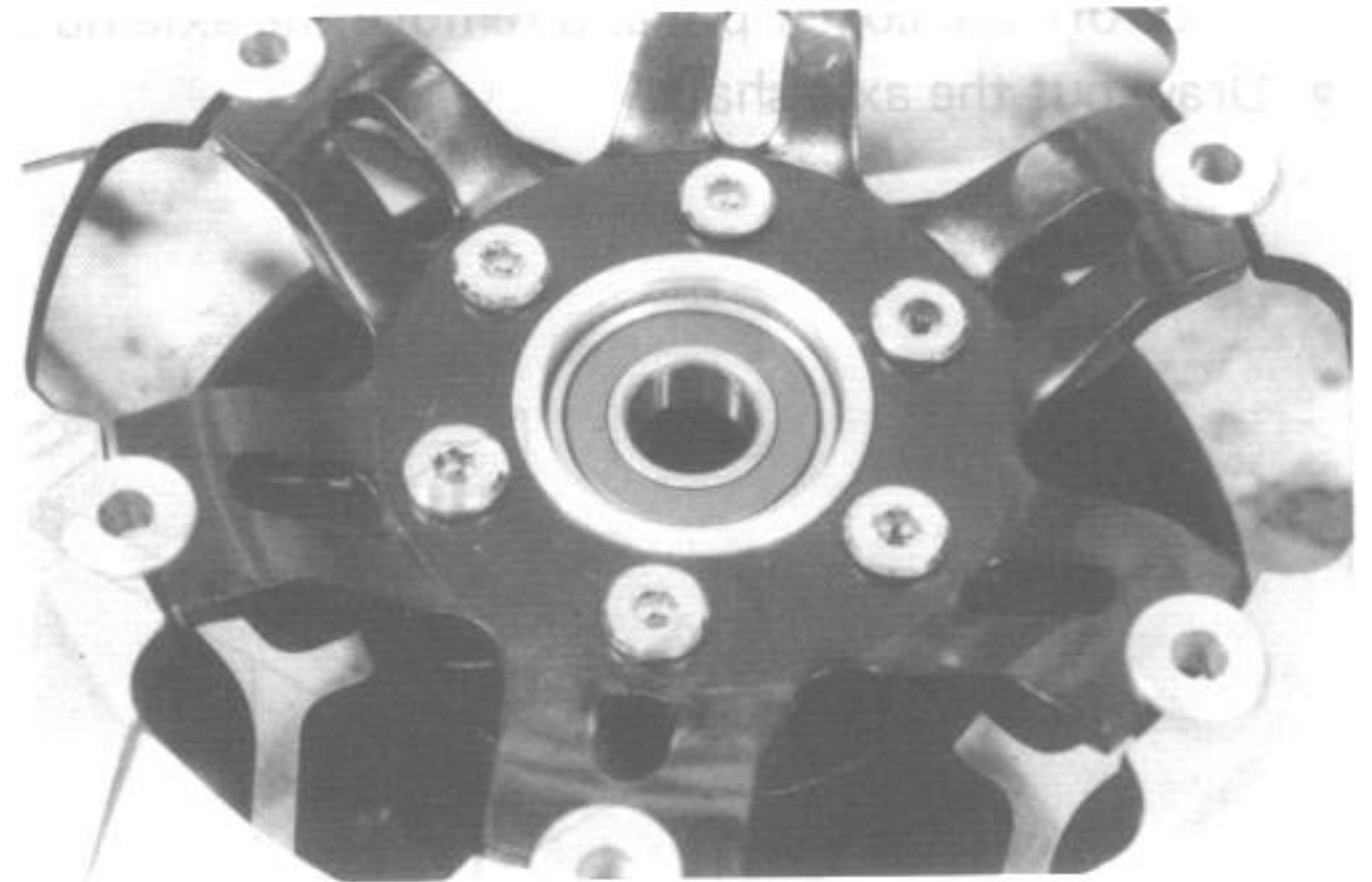

- Drive out wheel bearings, right and left, as well as front wheel bearing. (Refer to page 6-3.)

CAUTION:
The removed bearing should be replaced.

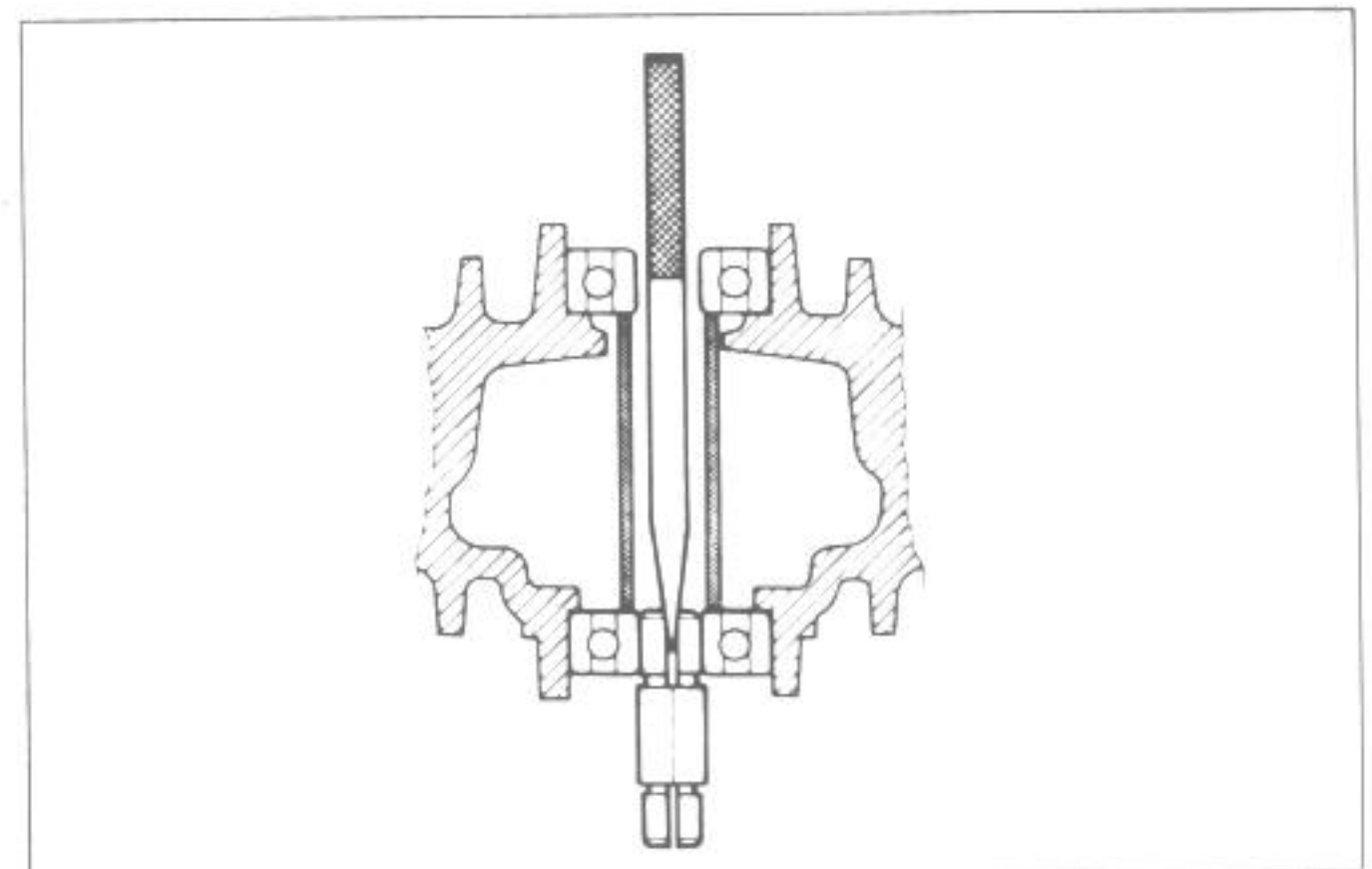

- Flatten the lock washer and remove the six nuts.
- Separate the rear sprocket from mounting drum.

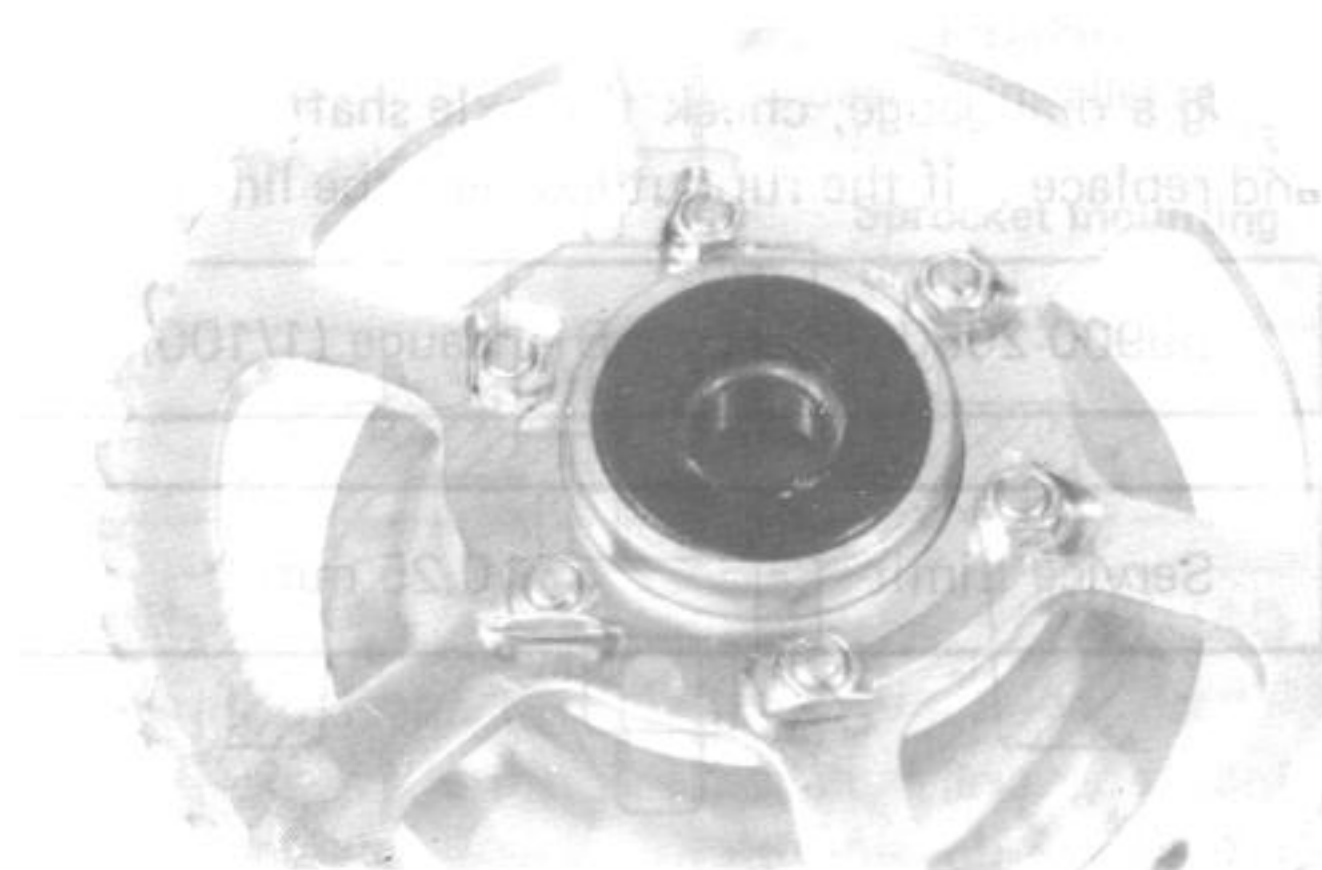

- Remove the oil seal by using the plain screw driver.

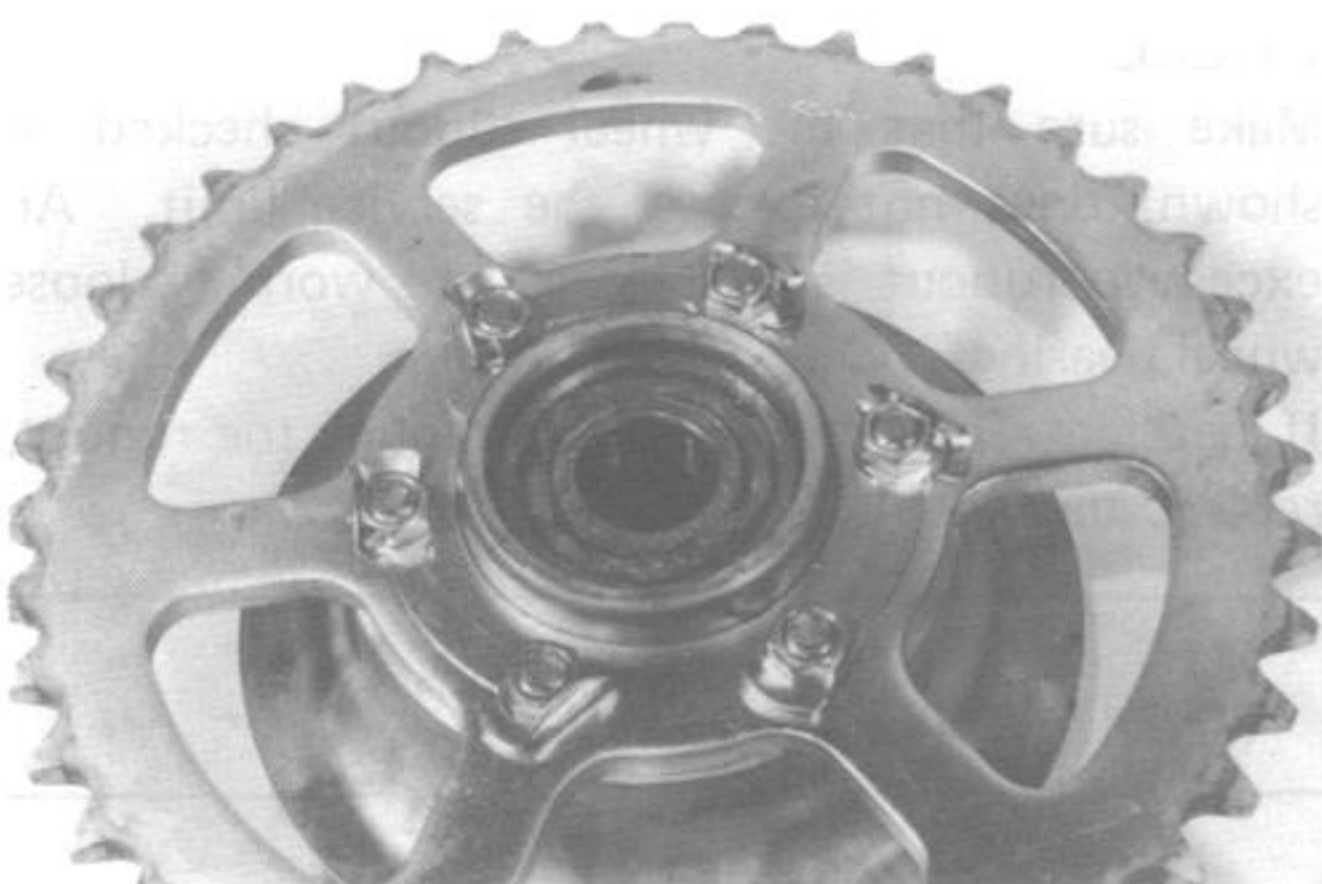

- Drive out sprocket mounting drum bearings.

CAUTION:
The removed bearing should be replaced.

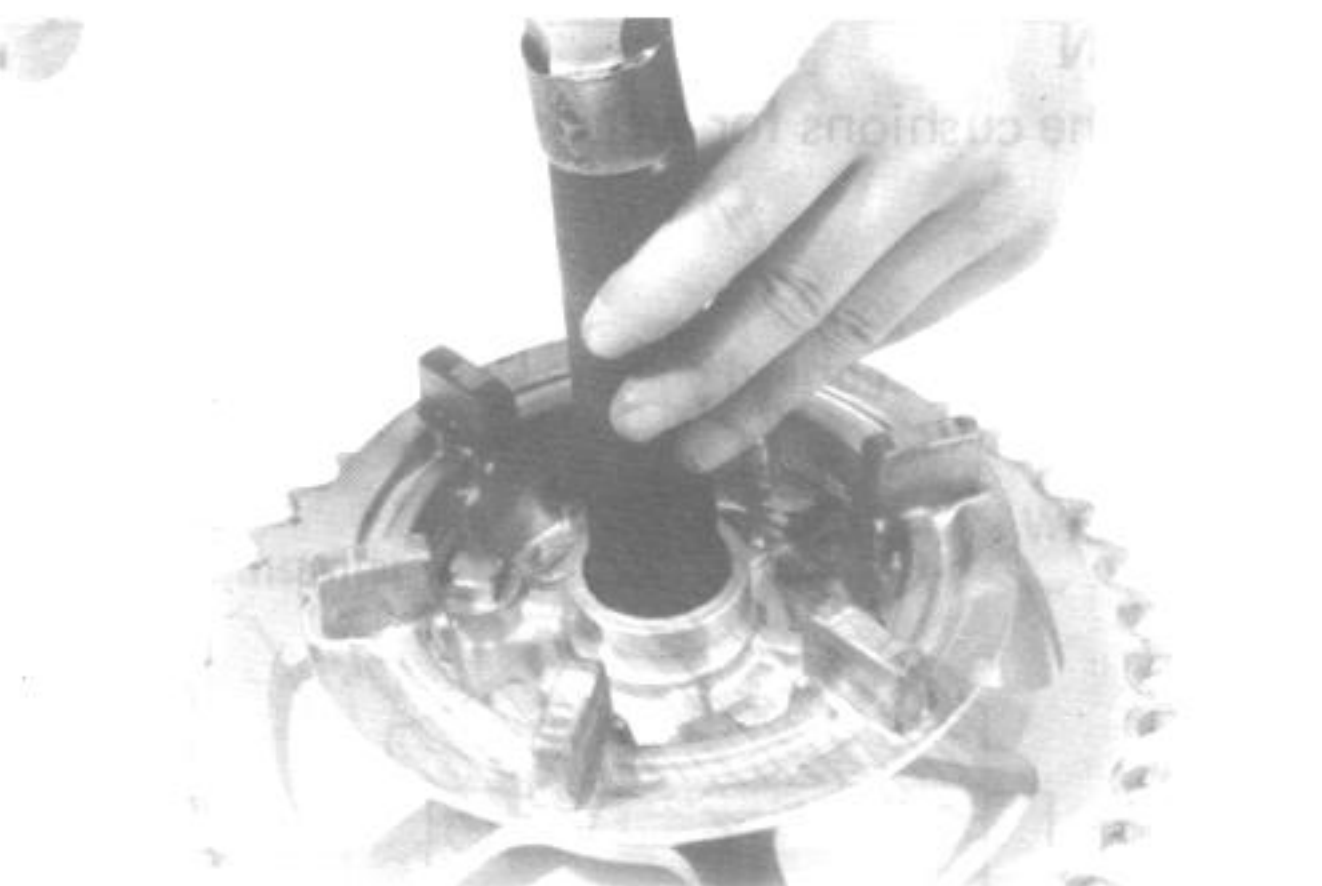

INSPECTION

REAR WHEEL AND MOUNTING DRUM BEARINGS

Inspect the play of bearing inner race by hand while fixing it in the wheel and mounting drum. Rotate the inner race by hand to inspect whether abnormal noise occurs or rotating smoothly. Replace the bearing if there is something unusual.

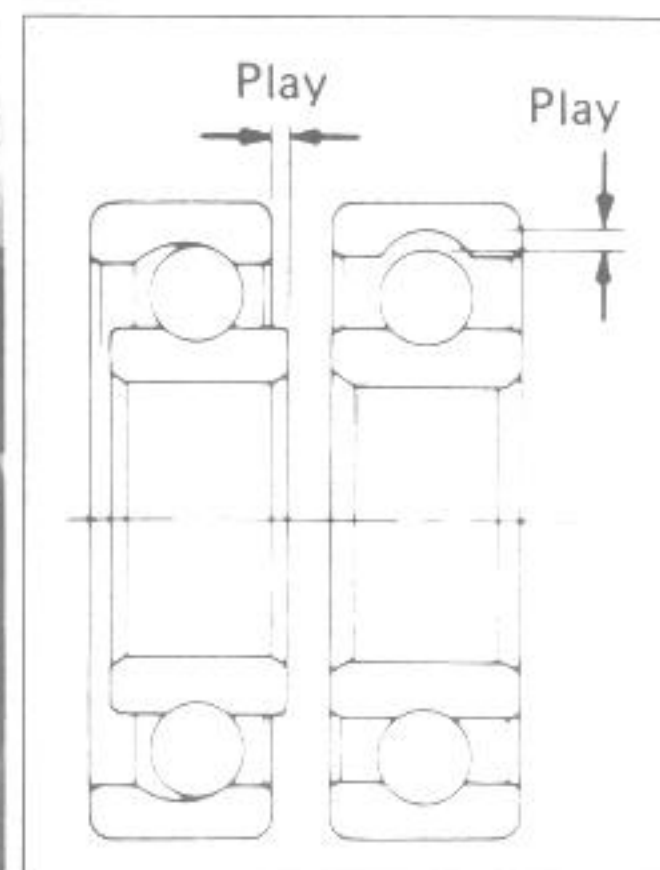
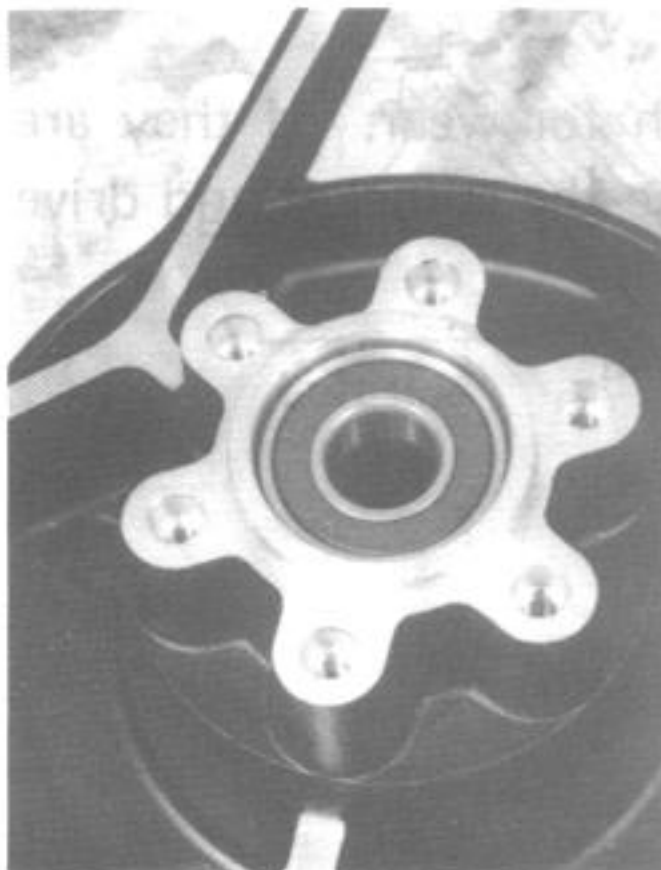

AXLE SHAFT

Using a dial gauge, check the axle shaft for runout and replace it if the runout exceeds the limit.

09900-20606	Dial gauge (1/100)
-------------	--------------------

Service Limit	0.25 mm
---------------	---------

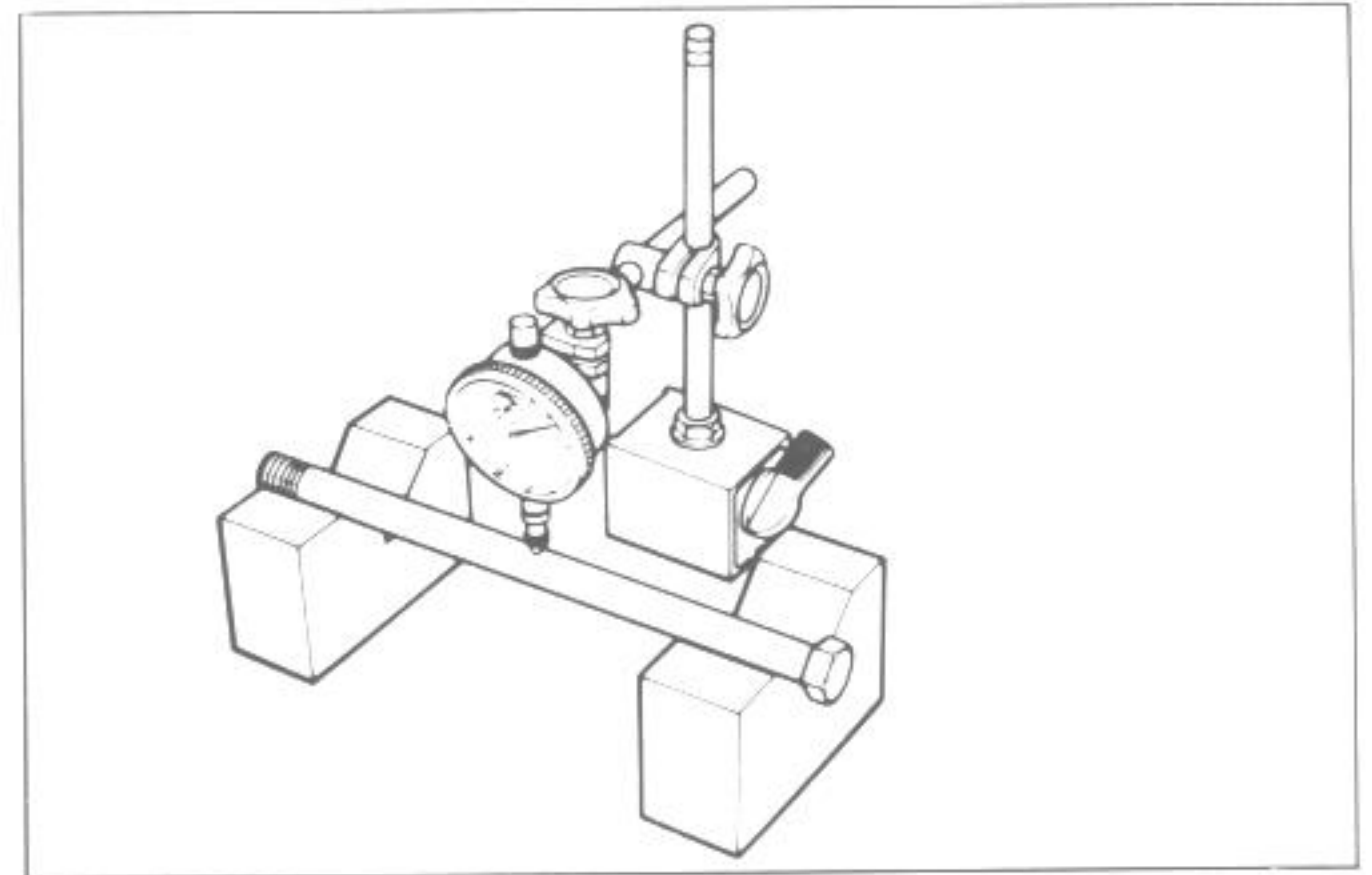
**WHEEL**

Make sure that the wheel runout checked as shown, does not exceed the service limit. An excessive runout is usually due to worn or loose wheel bearings.

If bearing replacement fails to reduce the runout, replace the wheel.

Service Limit (Axial and Radial)	2.0 mm
-------------------------------------	--------

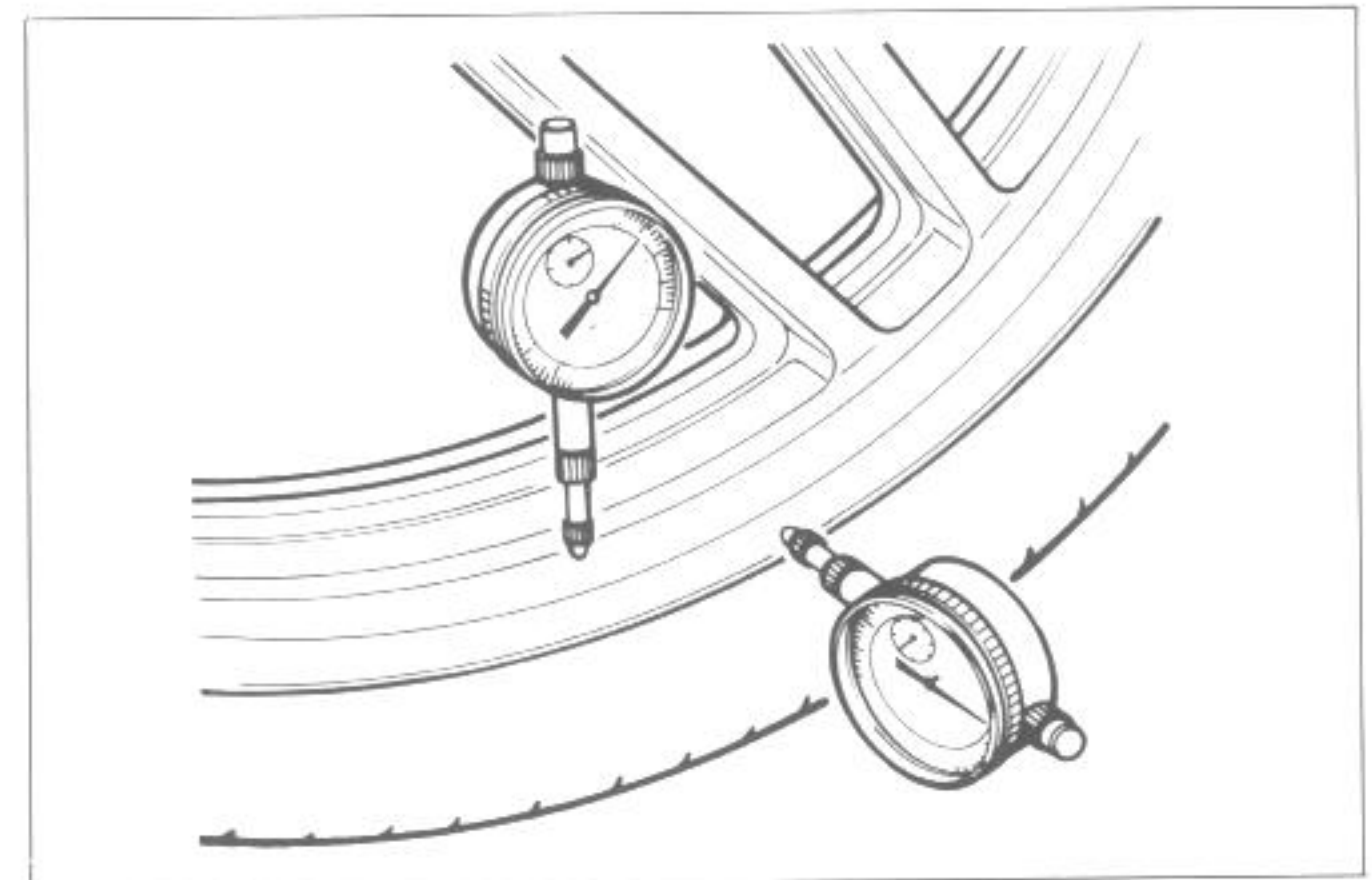
**CUSHION**

Inspect the cushions for wear and damage.

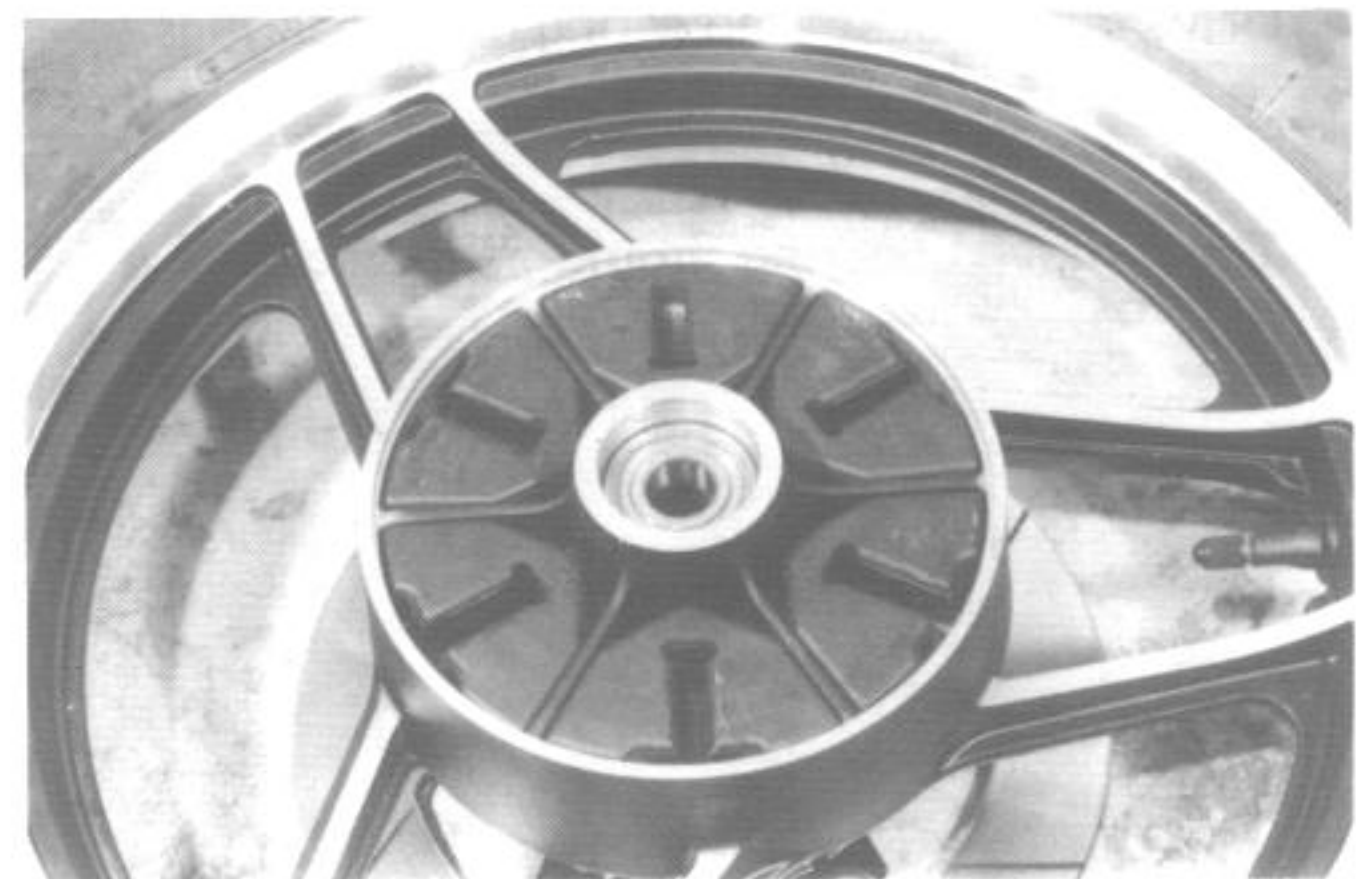
**SPROCKET**

Inspect the sprocket teeth for wear. If they are worn as illustrated, replace the sprocket and drive chain.

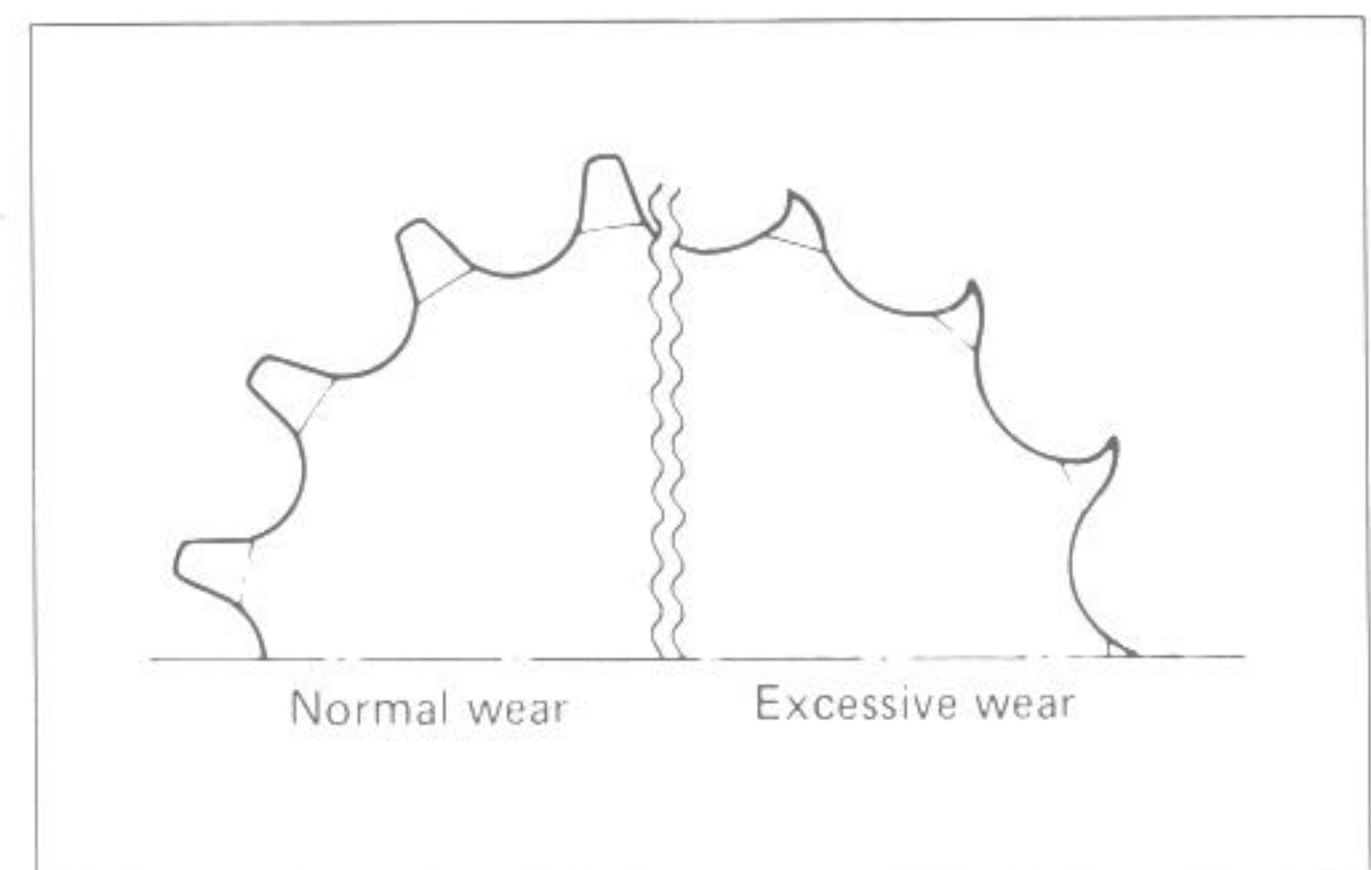

REASSEMBLY AND REMOUNTING

Reassemble and remount the rear wheel in the reverse order of disassembly and removal, and also carry out the following steps:

WHEEL BEARINGS

Install the wheel bearings by using the special tools.

09924-84510	Bearing installer set
-------------	-----------------------

NOTE:

First install the wheel bearing for right side.

MOUNTING DRUM BEARING

Install the bearing by using the special tool.

NOTE:

Apply grease to the bearing and oil seal lip before assembling rear wheel.

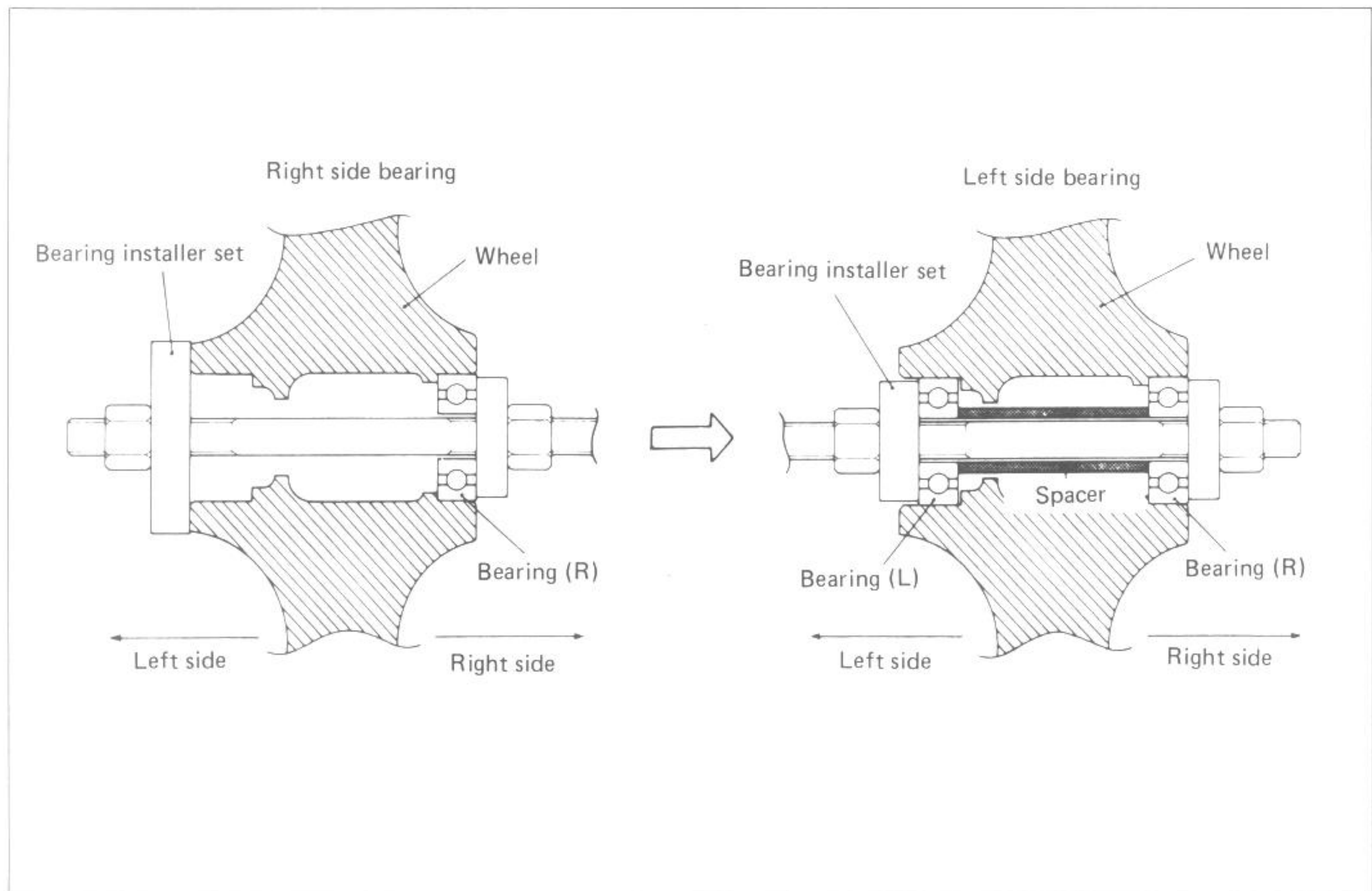
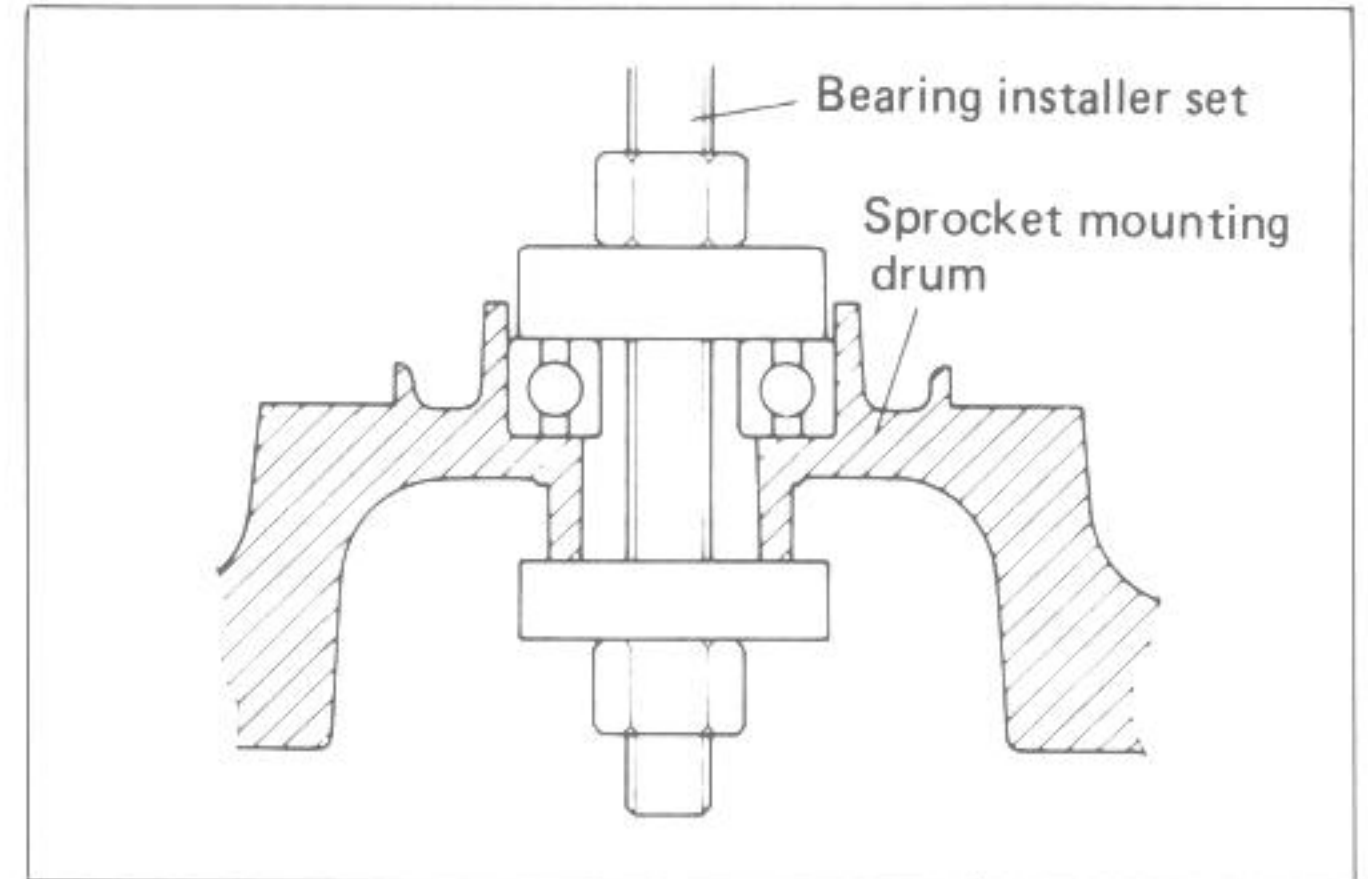

BRAKE DISC

Make sure that the brake disc is clean and free of any greasy matter. Tighten disc bolts to the specified torque.

Tightening torque	15 – 25 N·m (1.5 – 2.5 kg-m)
-------------------	---------------------------------

CAUTION:
These bolts are coated with special thread lock and are replaced five times before they must be replaced with new ones.

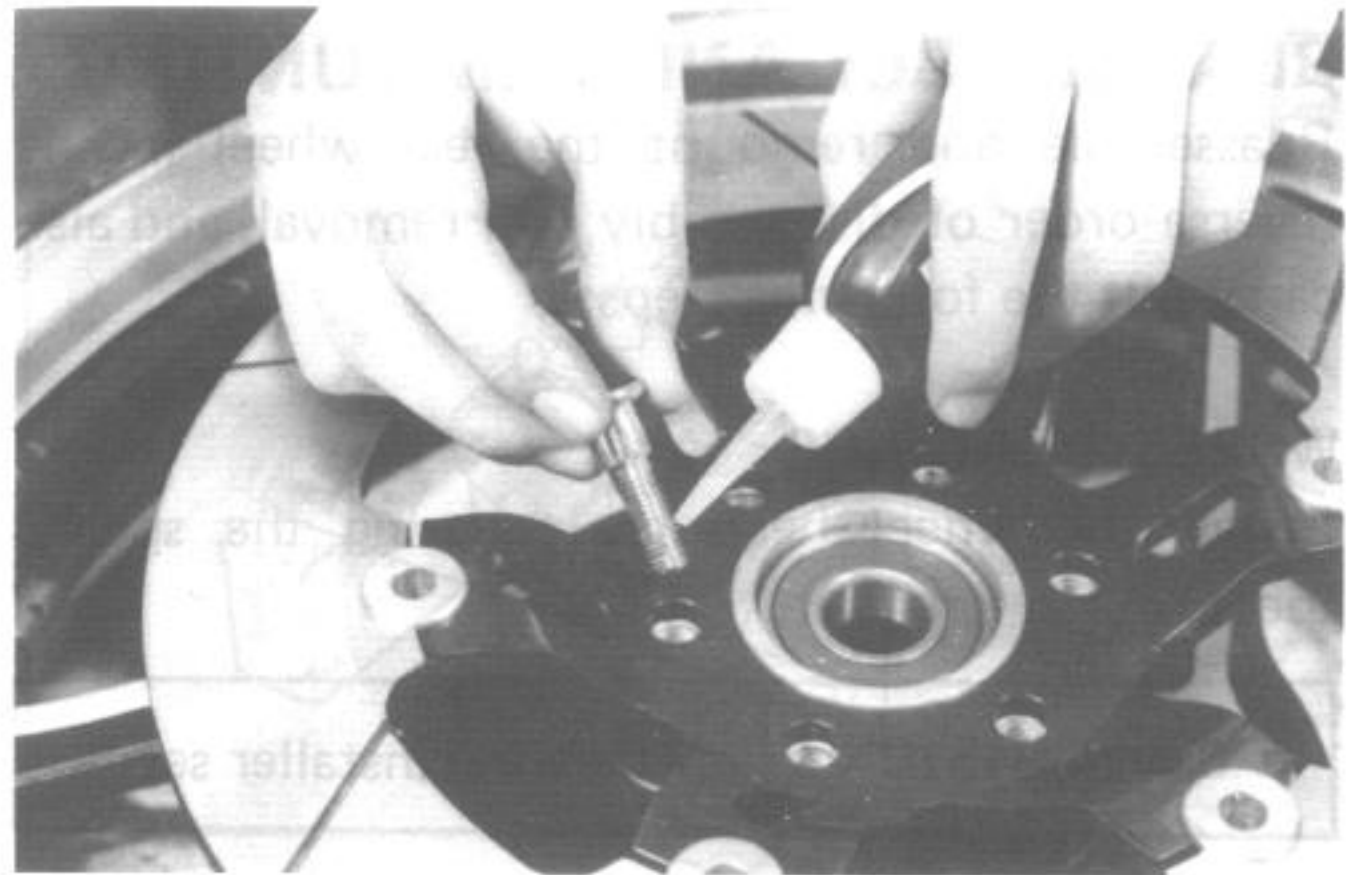

REAR SPROCKET

Install the rear sprocket to the mounting drum and bent the lock washer positively.

Tightening torque	25 – 40 N·m (2.5 – 4.0 kg-m)
-------------------	---------------------------------

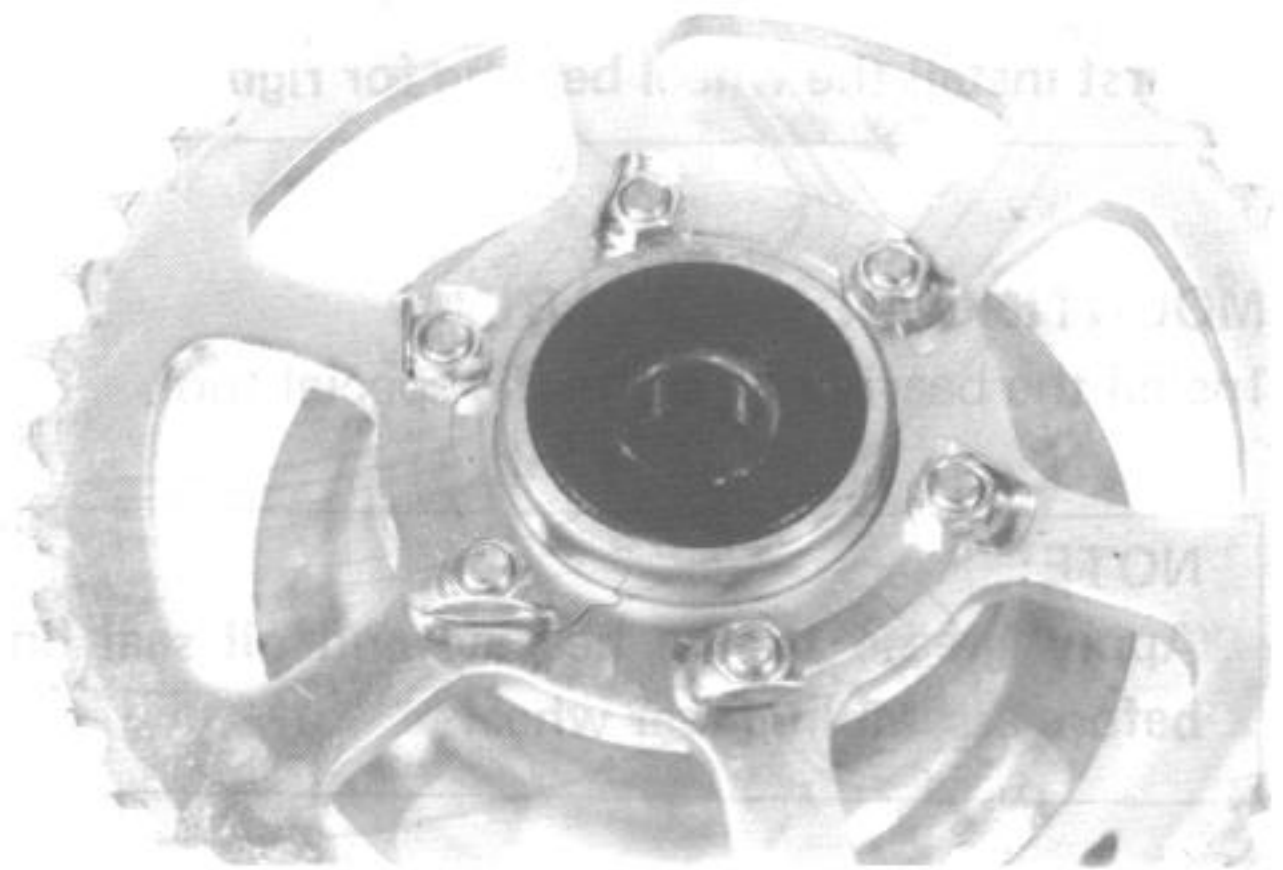

REAR WHEEL ASSEMBLY

Remount the rear wheel assembly as shown in the illustration.

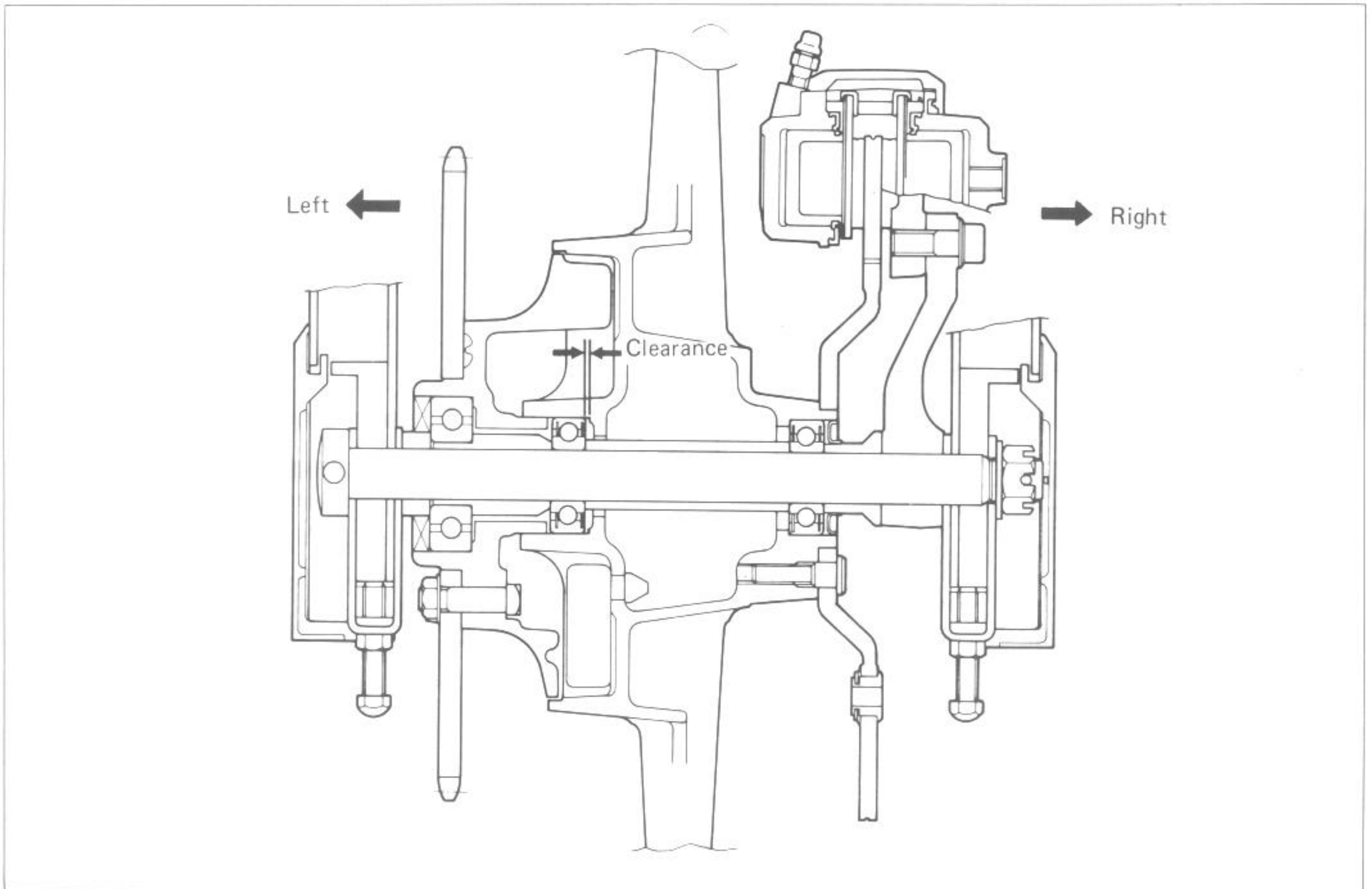

TIRE AND WHEEL

REMOVAL

The most critical factor of a tubeless tire is the seal between the wheel rim and the tire bead. Because of this, we recommend using a tire changer which is also more efficient than tire levers.

For tire removal the following tools are required.

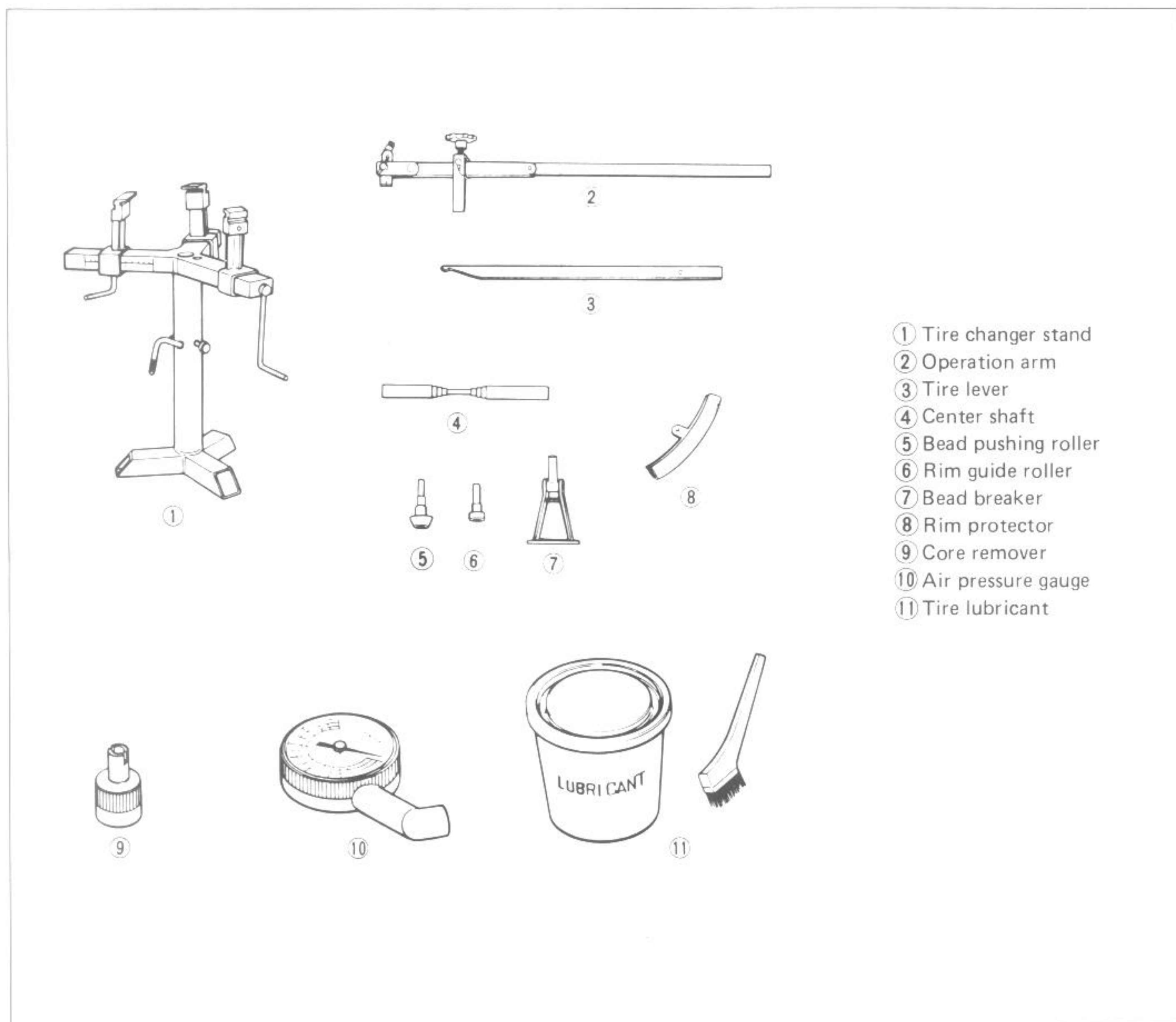

- Remove the valve core from the valve stem, and deflate the tire completely.

NOTE:

Mark tire with chalk to note the position ① of the tire on the rim and rotational direction ② of the tire.

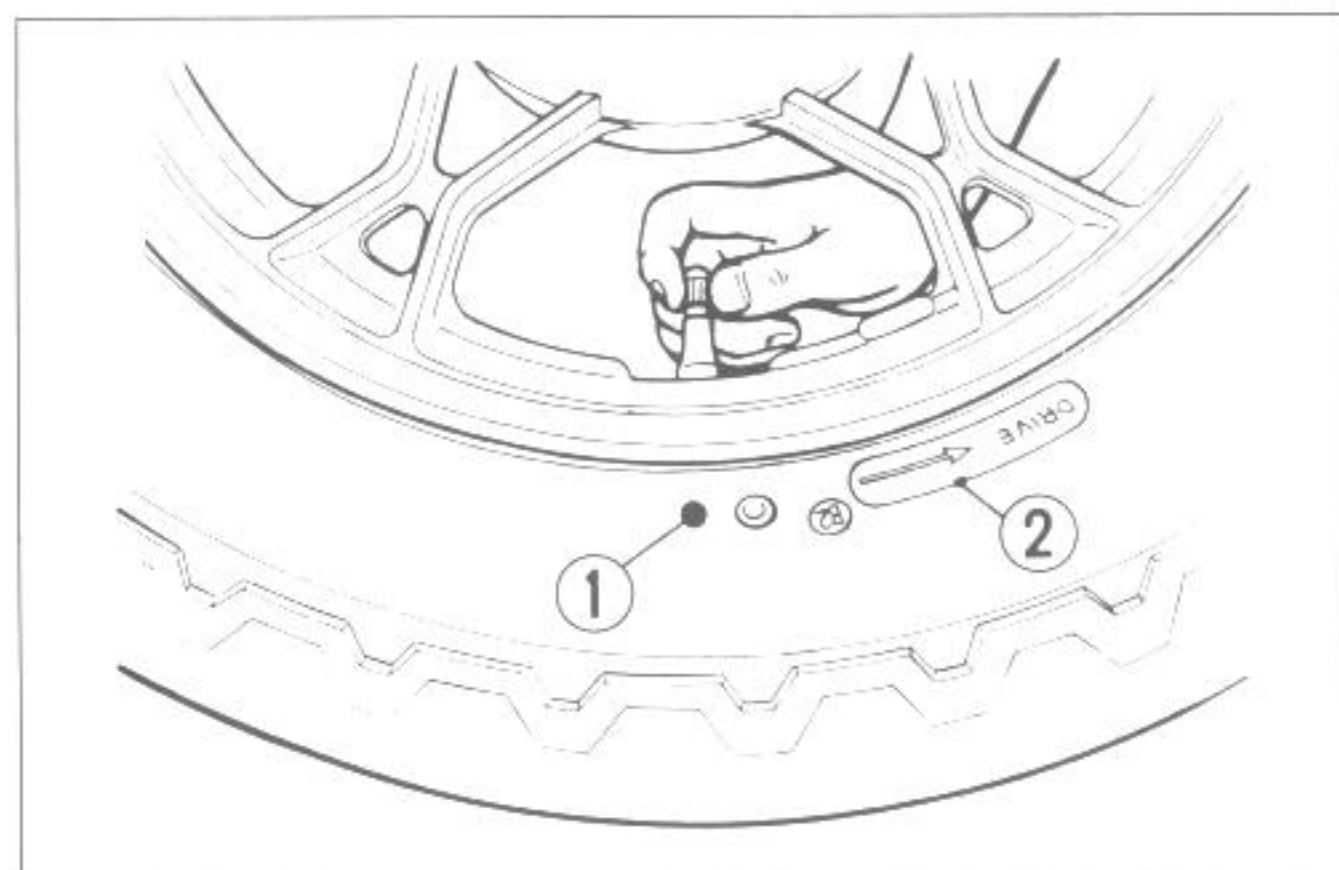

- Place the center shaft ① to the wheel, and fix the wheel firm by the rim holder ②.

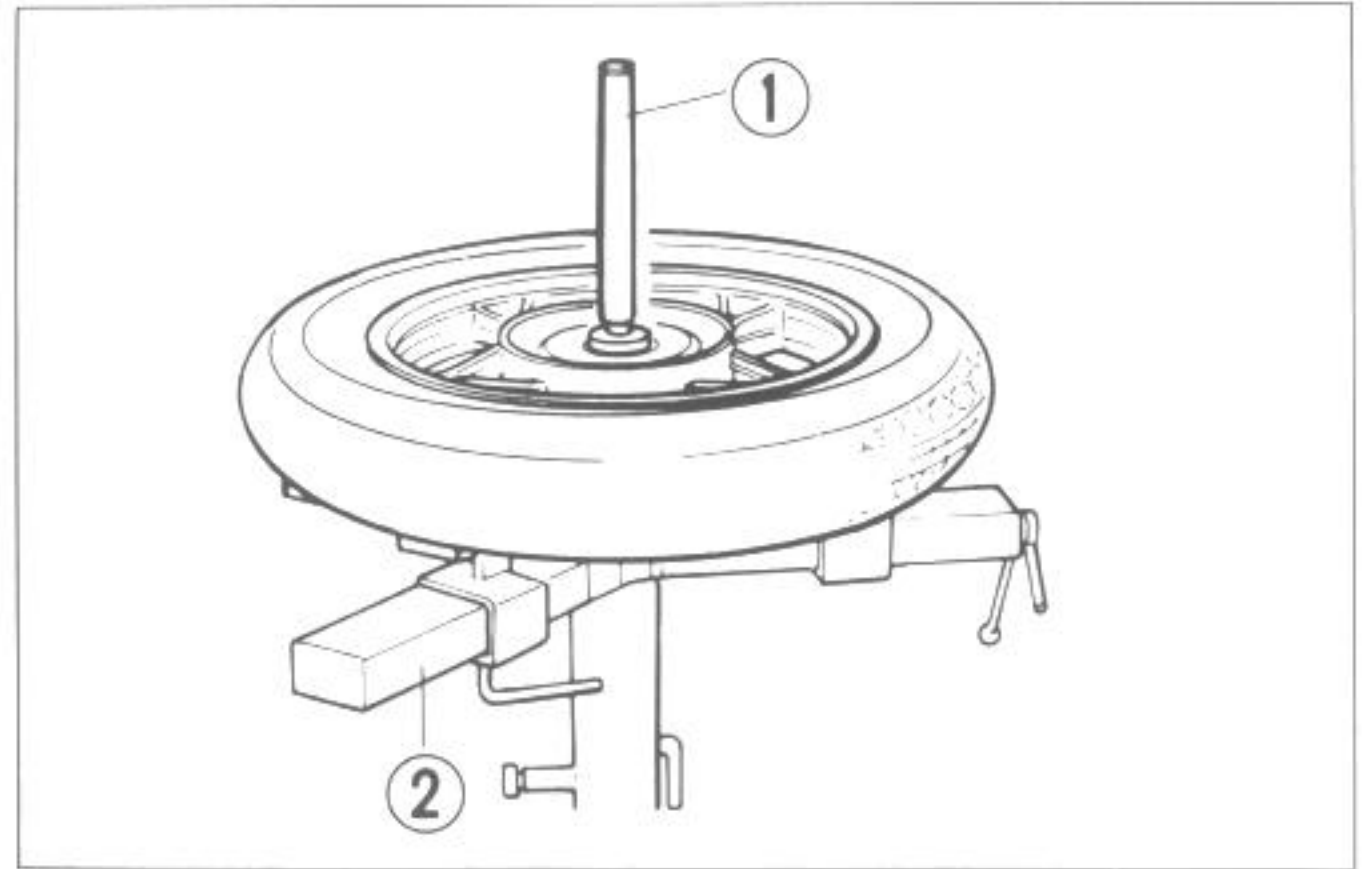

- Attach the operation arm ③ to the center shaft.

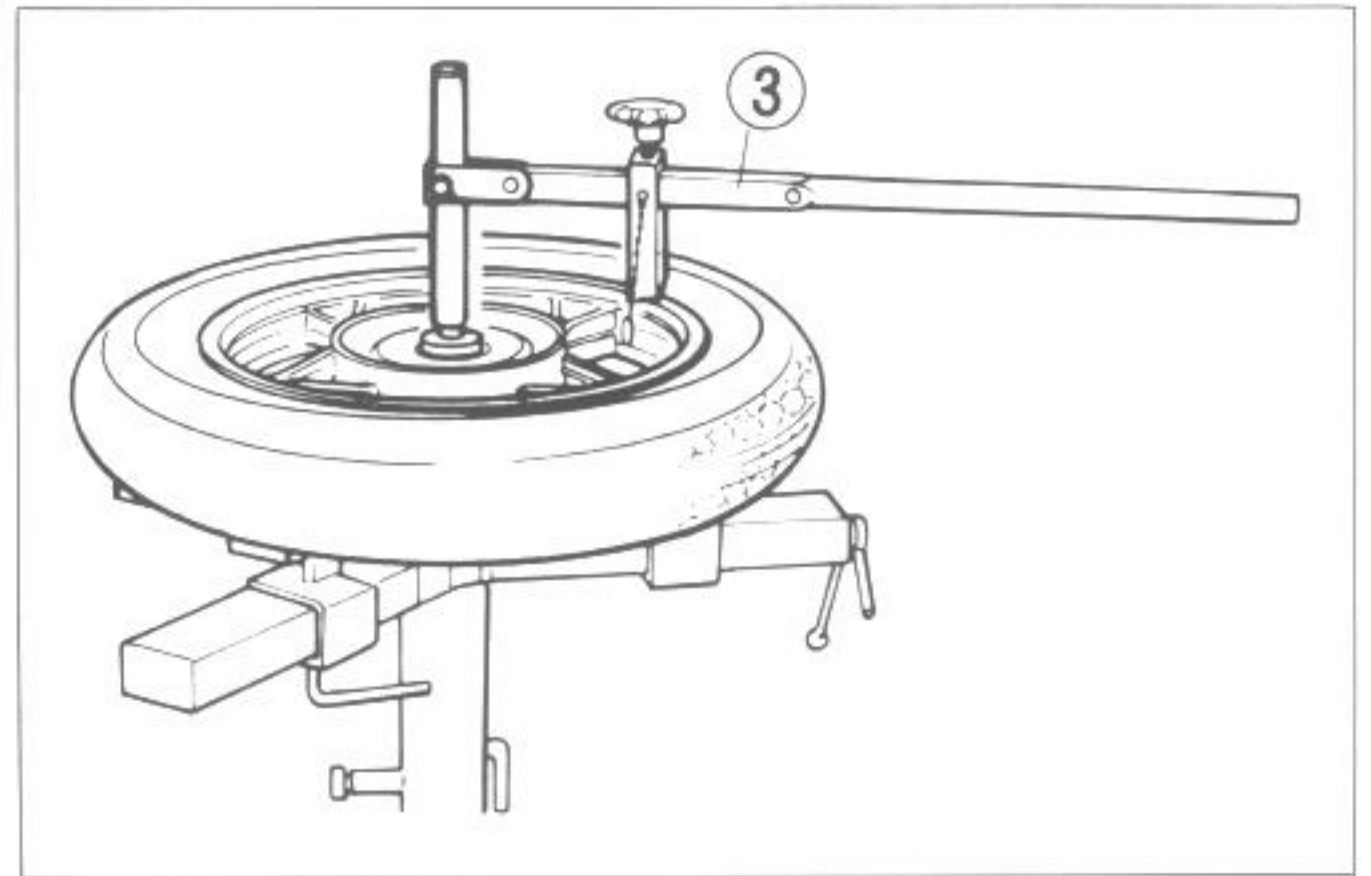

- Attach the bead breaker ④ to the operation arm, and dismount the bead from the rim. Turn the wheel over and dismount the other bead from the rim.

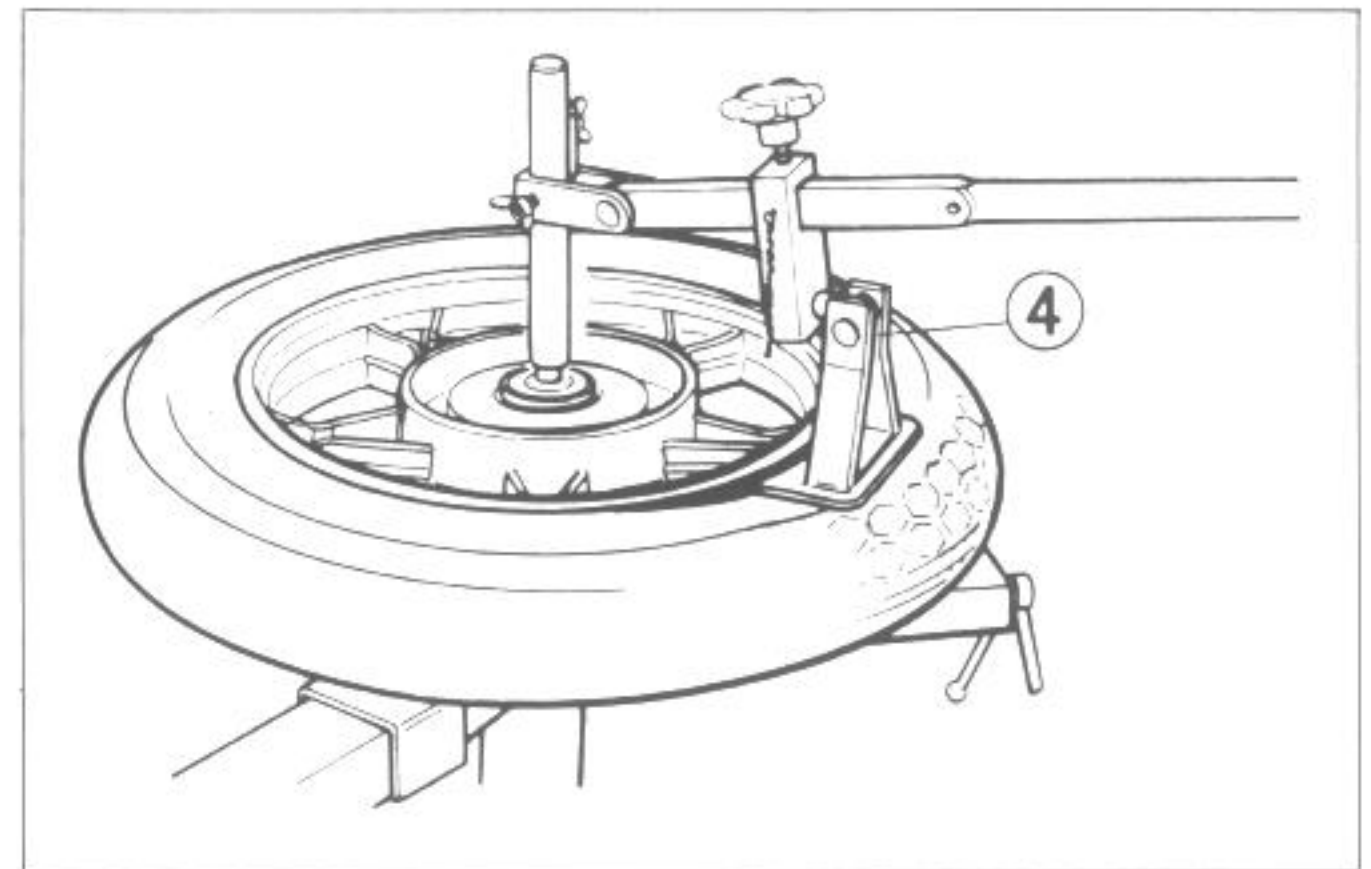

- Install the rim guide roller ⑤.
- Install the rim protector ⑥, and raise the tire bead with the tire lever ⑦.

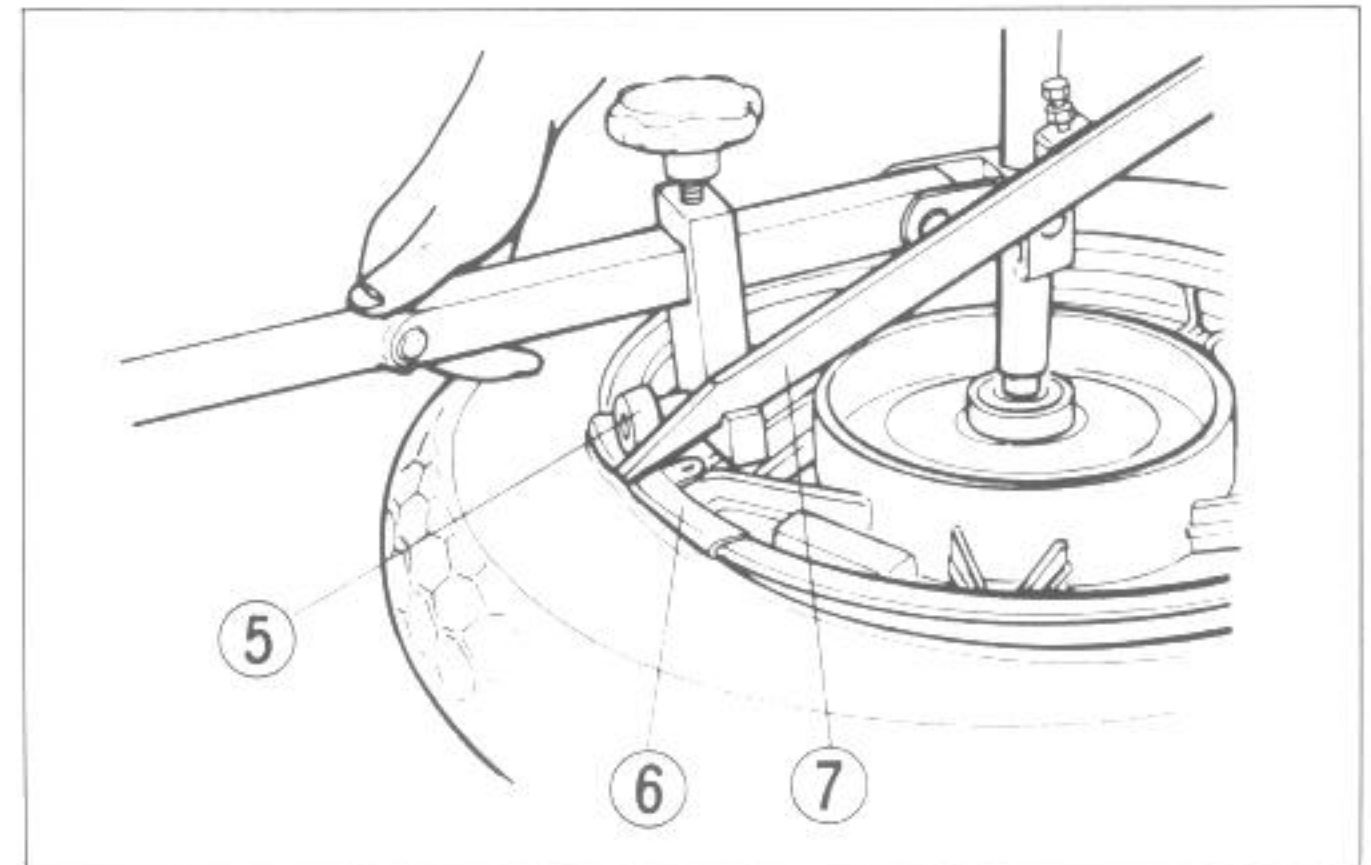

- Set the tire lever against the operation arm, and rotate the lever around the rim. Repeat this procedure to remove the other bead from the rim.

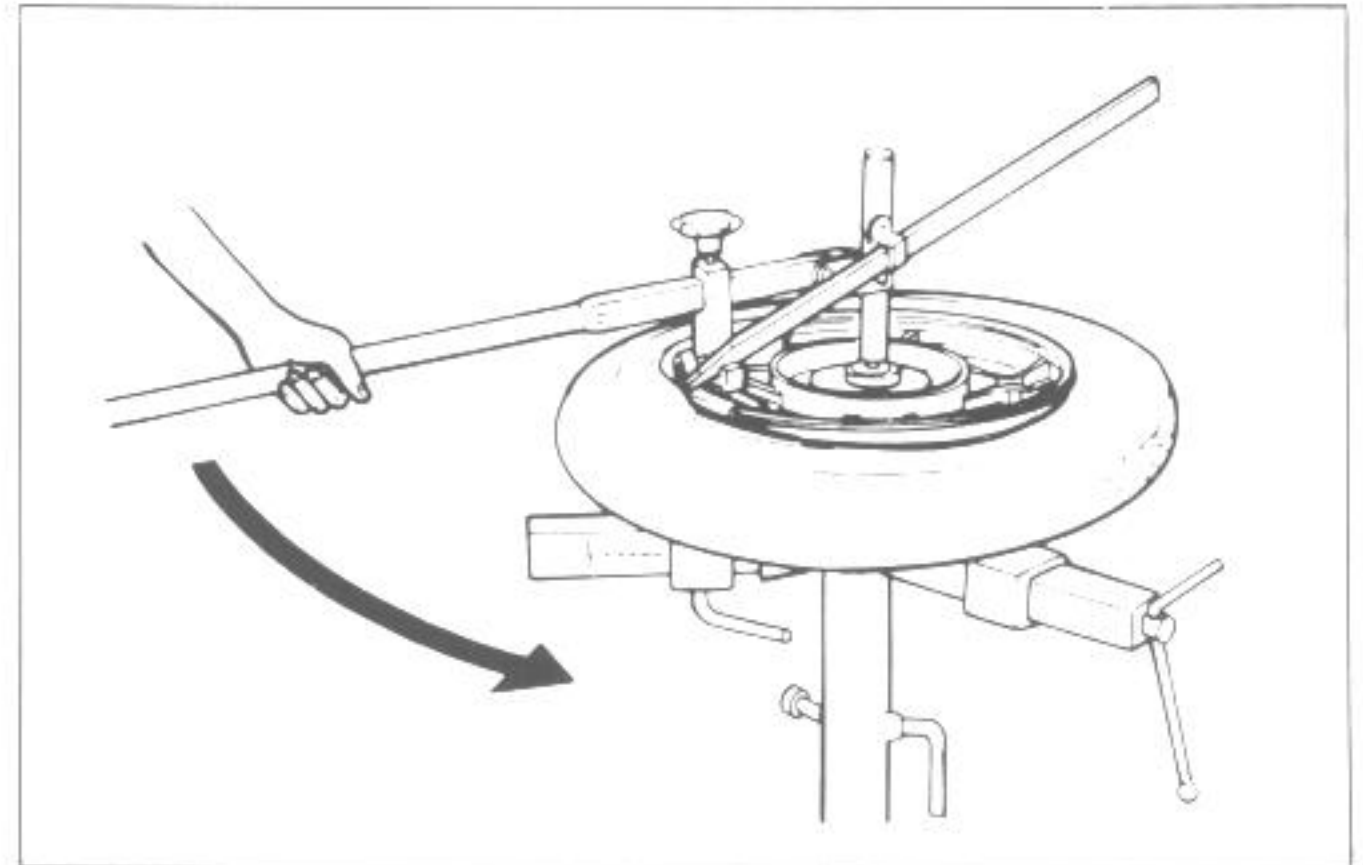

INSPECTION

WHEEL

Wipe off any rubber substance or rust from the wheel, and inspect the wheel rim. If any one of the following items is observed, replace it with a new wheel.

- * A distortion or crack.
- * Any scratches or flaws in the bead seating area.
- * Wheel runout (Axial & Radial) of more than 2.0 mm.

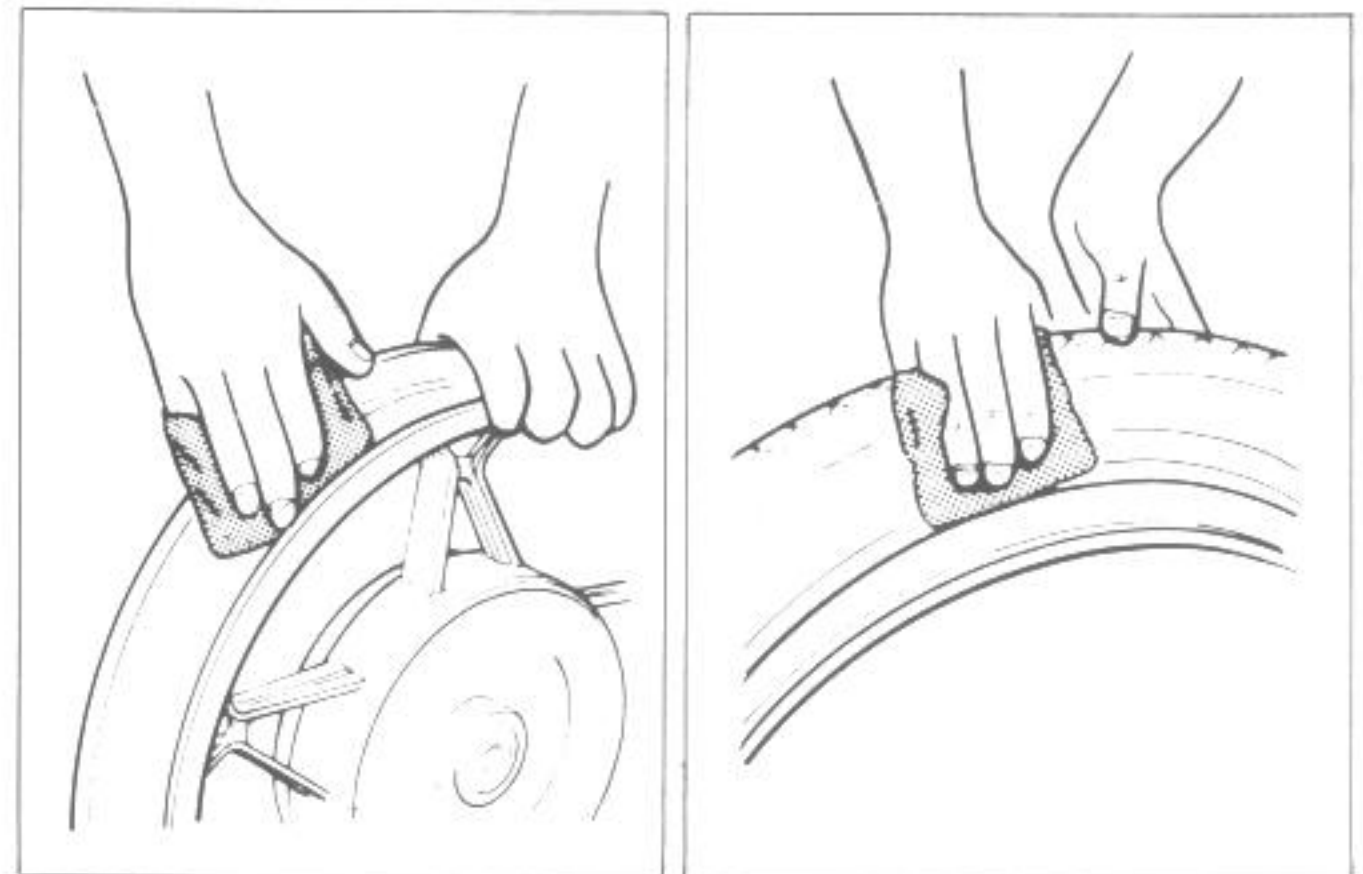

TIRE

Thoroughly inspect the removed tire, and if any one of the following items is observed, do not repair the tire. Replace with the new one.

- * A puncture or a split whose total length or diameter exceeds 6 mm.
- * A scratch or split at the side wall.
- * Tread depth less than 1.6 mm in the front tire and less than 2.0 mm in the rear tire.
- * Ply separation.
- * Tread separation.
- * Tread wear is extraordinarily deformed or distributed around the tire.
- * Scratches at the bead.
- * Cord is cut.
- * Damage from skidding (flat spots).
- * Abnormality in the inner liner.

REPAIR

NOTE:

When repairing a flat tire, follow the repair instructions and use only recommended repairing materials.

VALVE INSPECTION

Inspect the valve after the tire is removed from the rim, and replace with the new valve if the seal rubber has any split or scratch.

Inspect the removed valve core and replace with the new one if seal rubber is abnormally deformed or worn.

INSTALLATION

Any dust or rust around the valve hole must be cleaned off. Then install the valve in the rim.

CAUTION:

When installing the valve, tighten the nut ① by hand as much as possible. Holding the nut under this condition, tighten the lock nut ②. Do not overtighten nut ① as this may distort the rubber packing and cause an air leak.

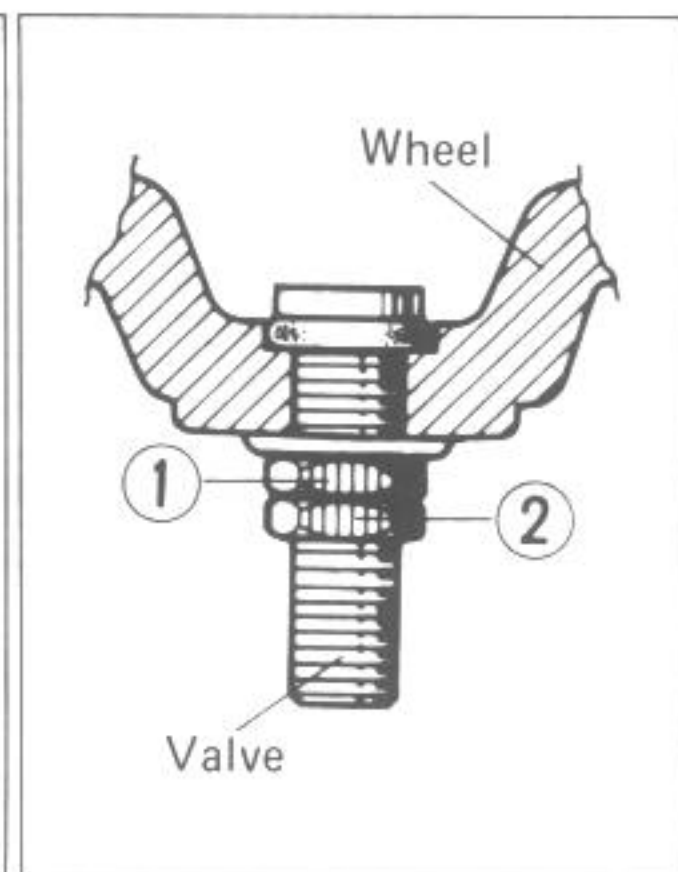
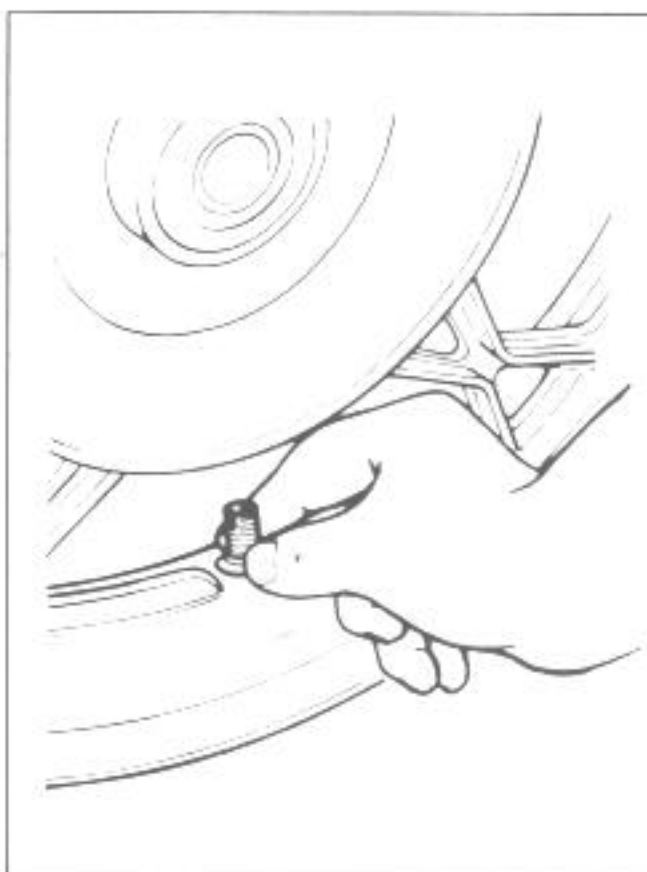
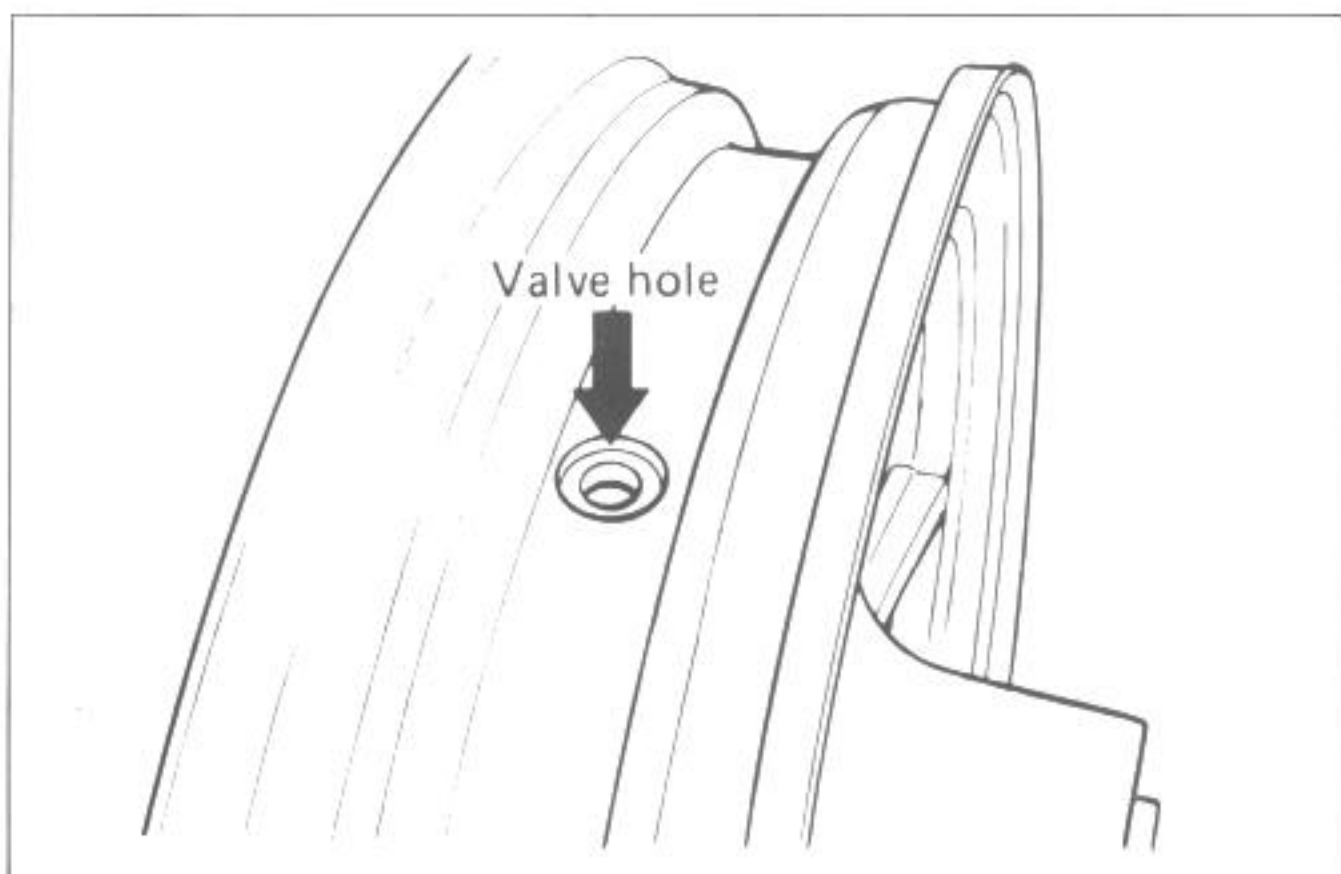
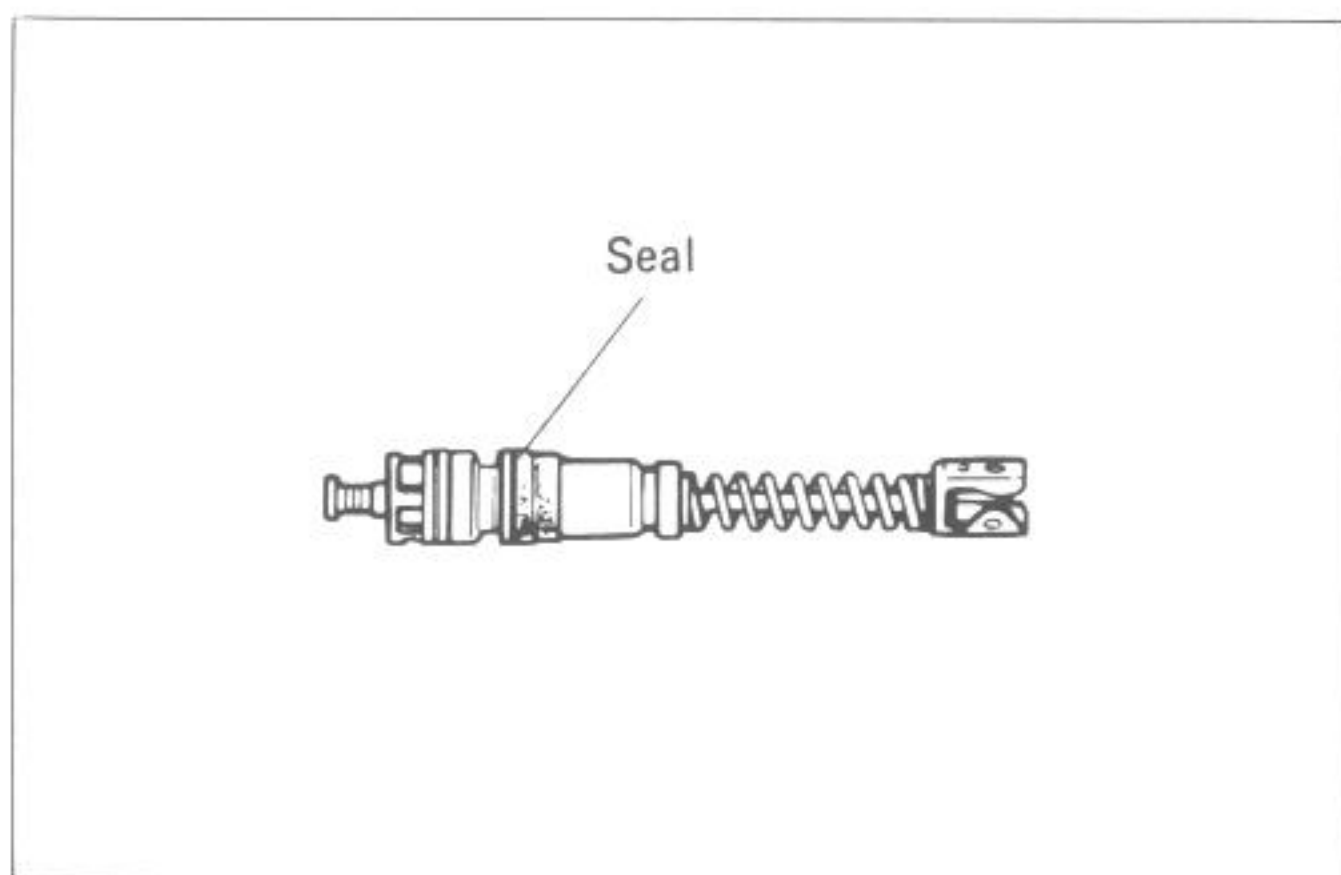
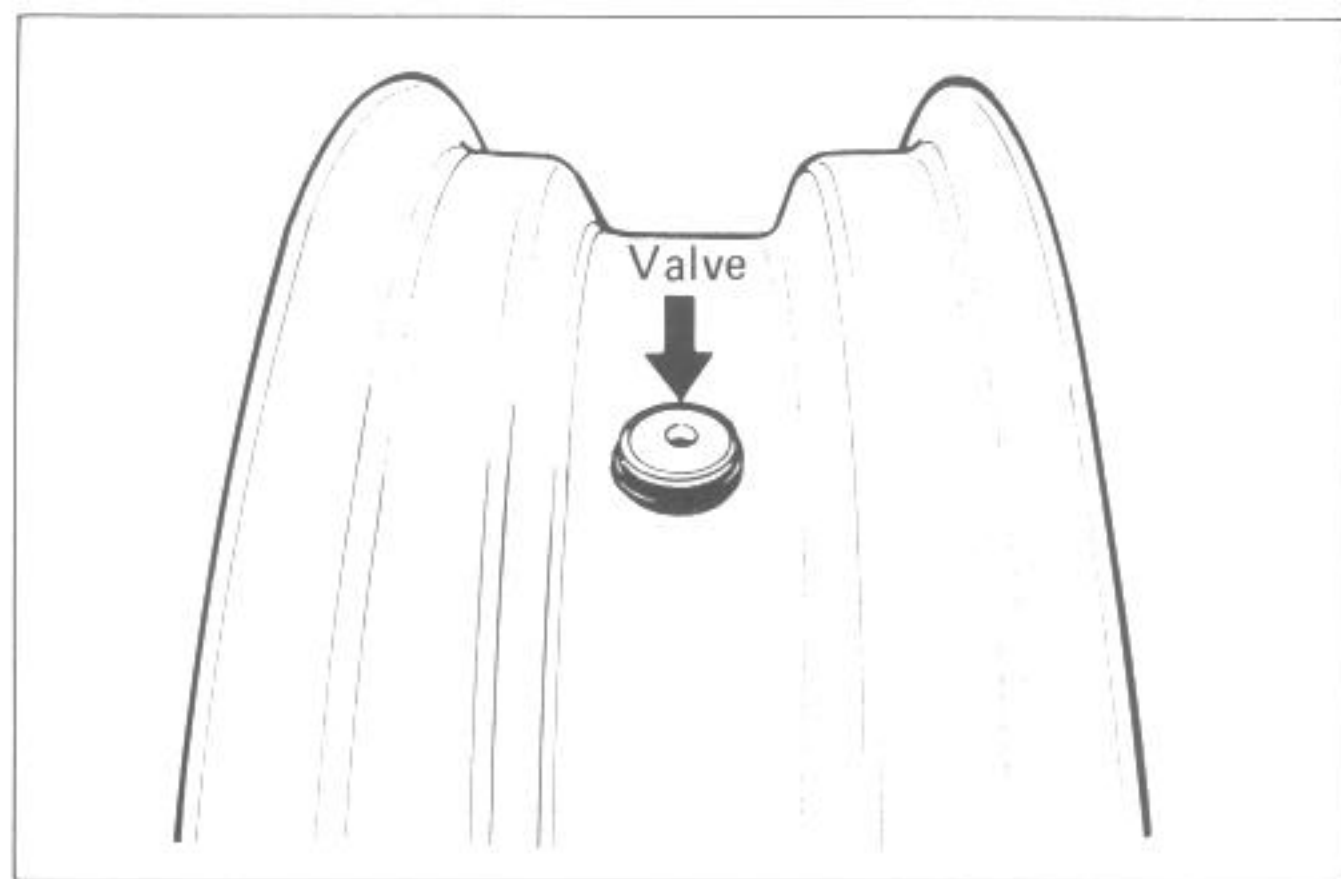

TIRE MOUNTING

- Apply a special tire lubricant or neutral soapy liquid to the tire bead.

CAUTION:

Never apply grease, oil or gasoline.

- When installing the tire, make certain that the directional arrow faces the direction of wheel rotation and align the balancing dot of the tire with the valve stem as shown.

- Set the bead pushing roller ①.
- Rotate operation arm around the rim to mount the bead completely. Do the bottom bead first, then the upper bead.
- Remove the wheel from the tire changer, and install the valve core in the valve stem.

NOTE:

Before installing the valve core, inspect the core.

- Bounce the tire several times while rotating. This makes the tire bead expand outwards, and thus makes inflation easier.

NOTE:

Before inflating, confirm that the balance mark lines up with the valve stem.

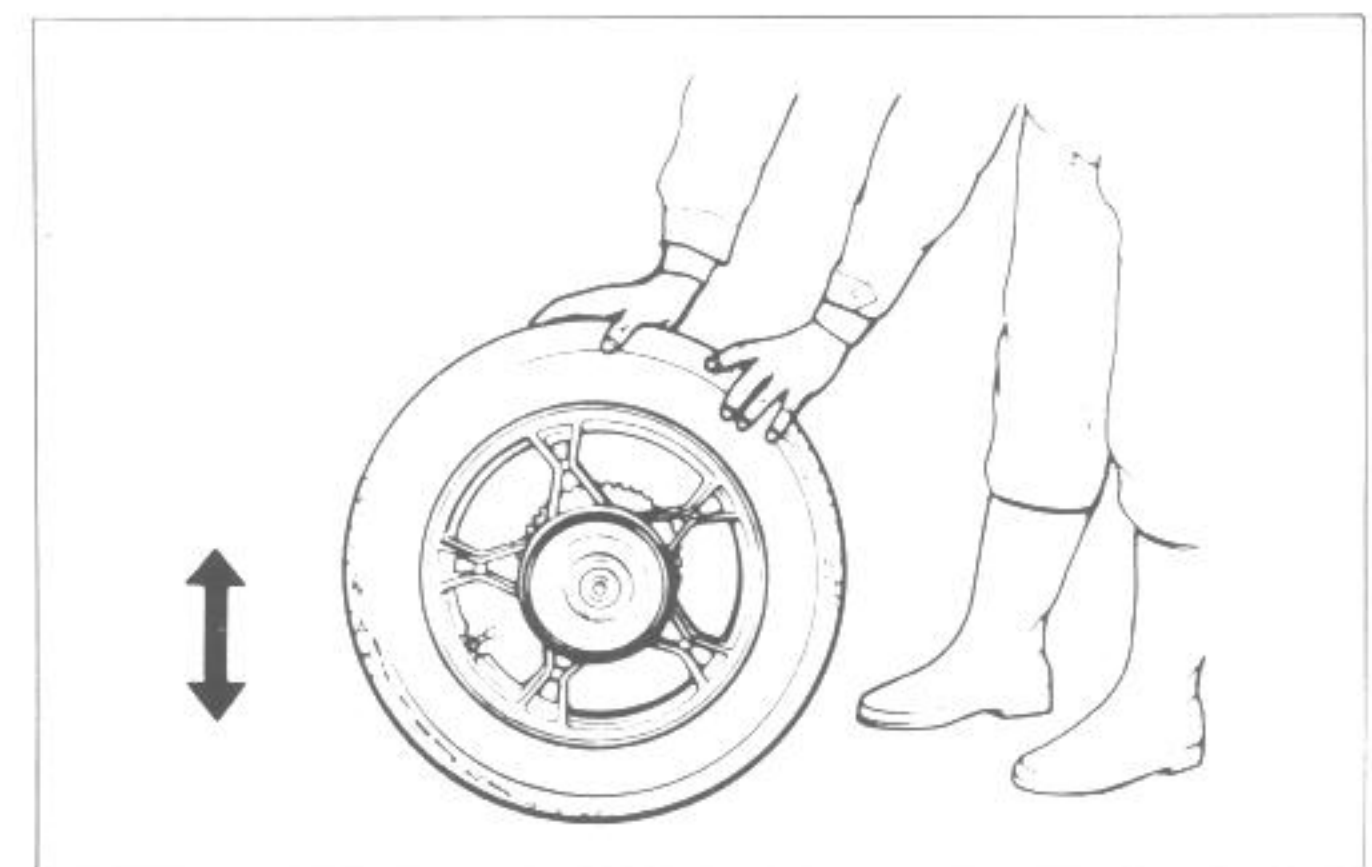
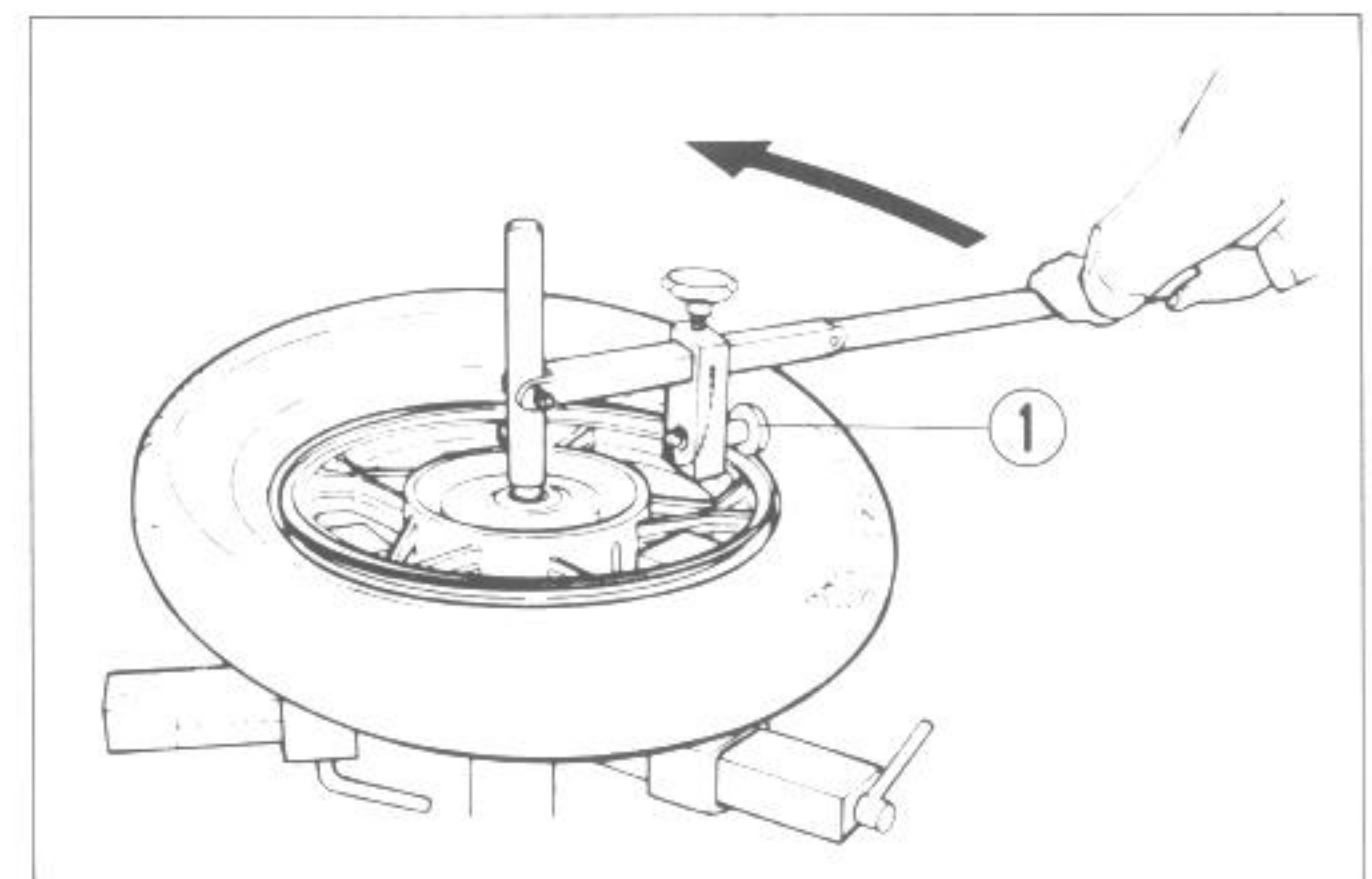
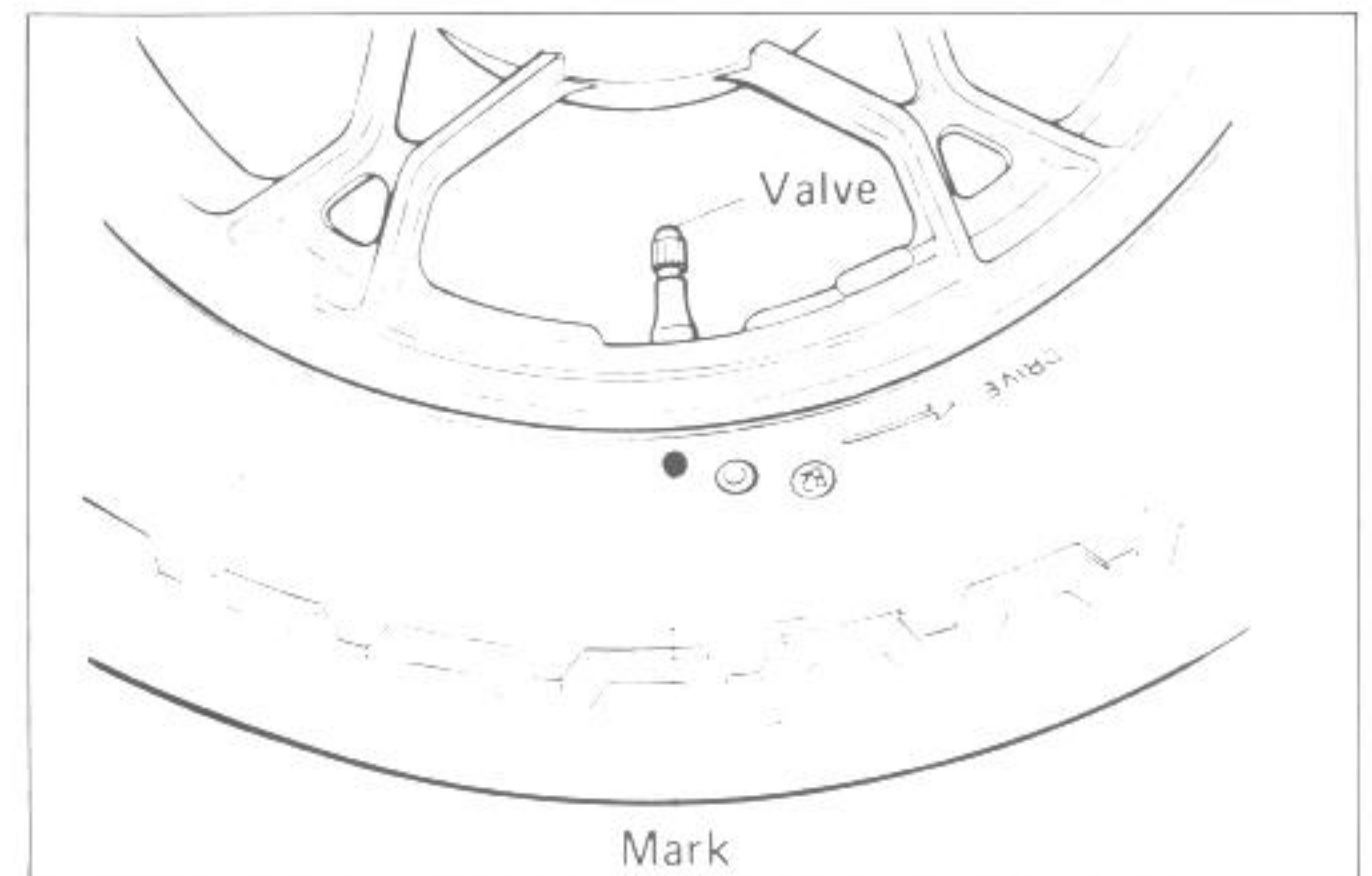
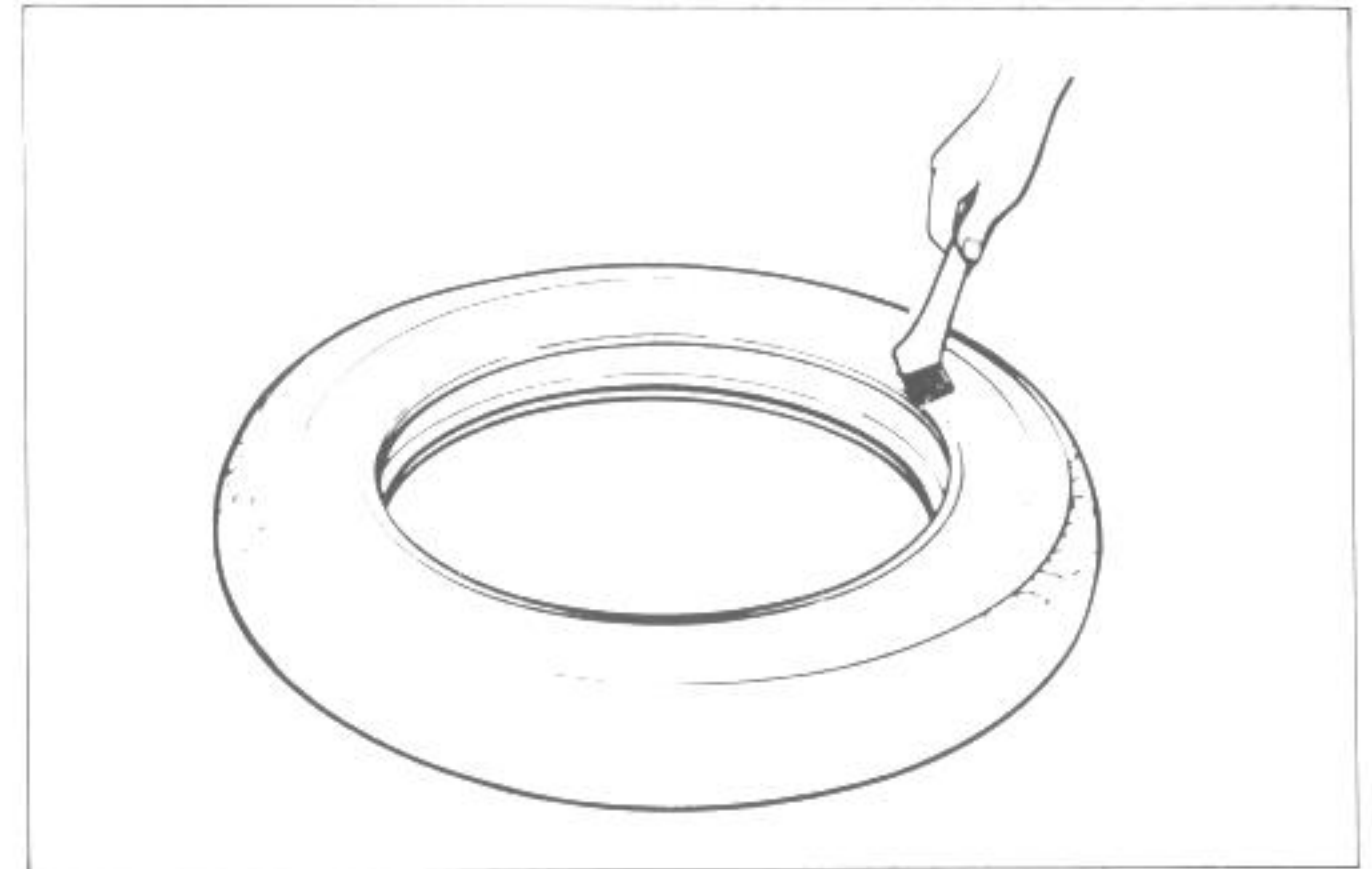

- Pump up the tire with air.

WARNING:

Do not inflate the tire to more than 4.0 kg/cm² (56 psi). The tire could burst with sufficient force to cause severe injury. Never stand directly over the tire while inflating it.

NOTE:

Check the "rim line" cast on the tire side walls. It must be an equal distance from the wheel rim all the way around. If the distance between the rim line and the wheel rim varies, this indicates that the bead is not properly seated. If this is so, deflate the tire completely, and unseat the bead for the both sides. Coat the bead with lubricant, and try again.

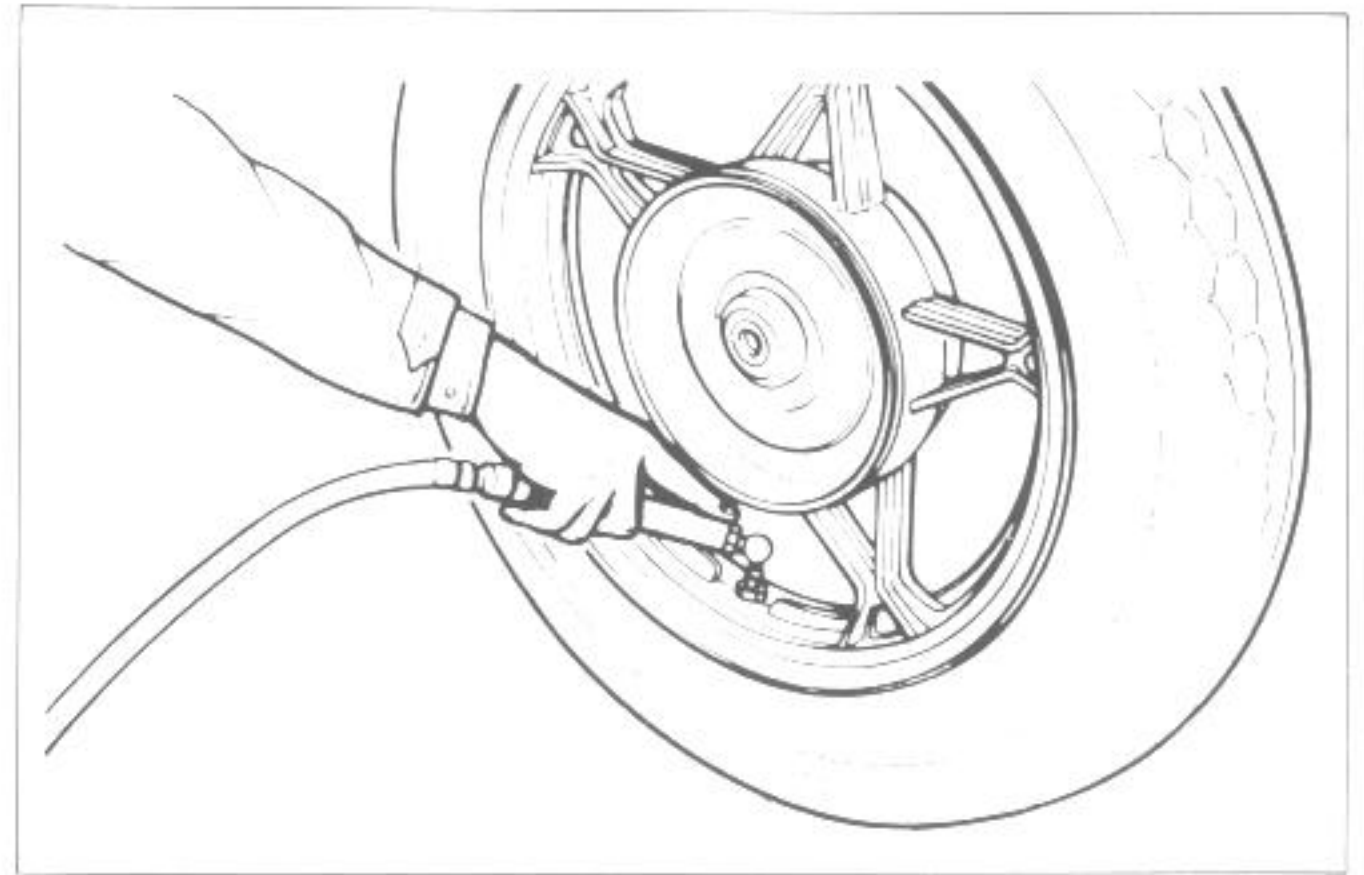

- After tire is properly seated to the wheel rim, adjust the pressure to the recommended pressure. Correct the wheel balance if necessary.

WARNING:

Do not run a repaired tire more than 50 km/h (30 mph) within 24 hours after tire repairing, since the patch may not be completely cured. Do not exceed 130 km/h (80 mph) with a repaired tire.

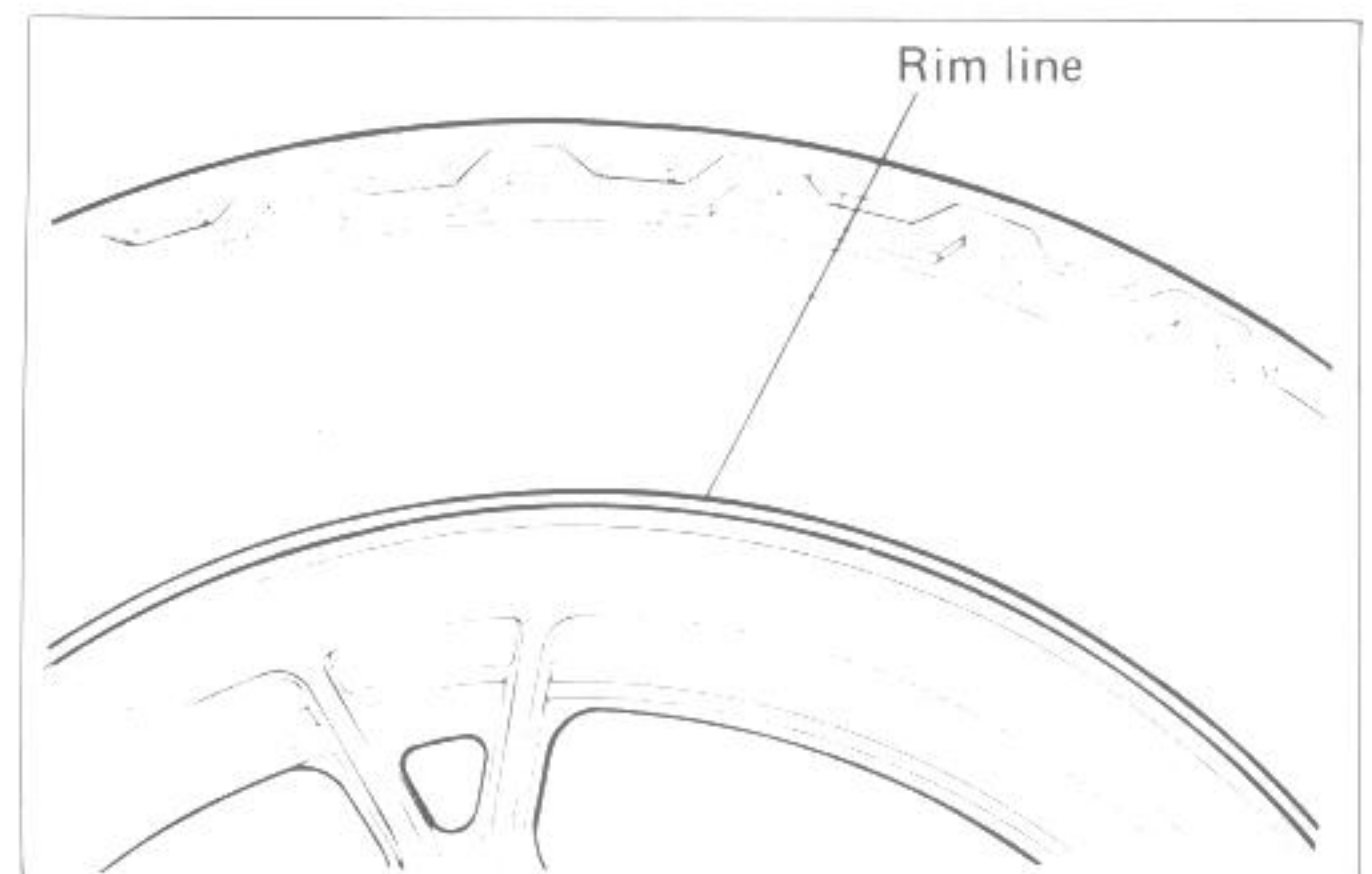

REAR SWINGARM AND SUSPENSION

SWINGARM

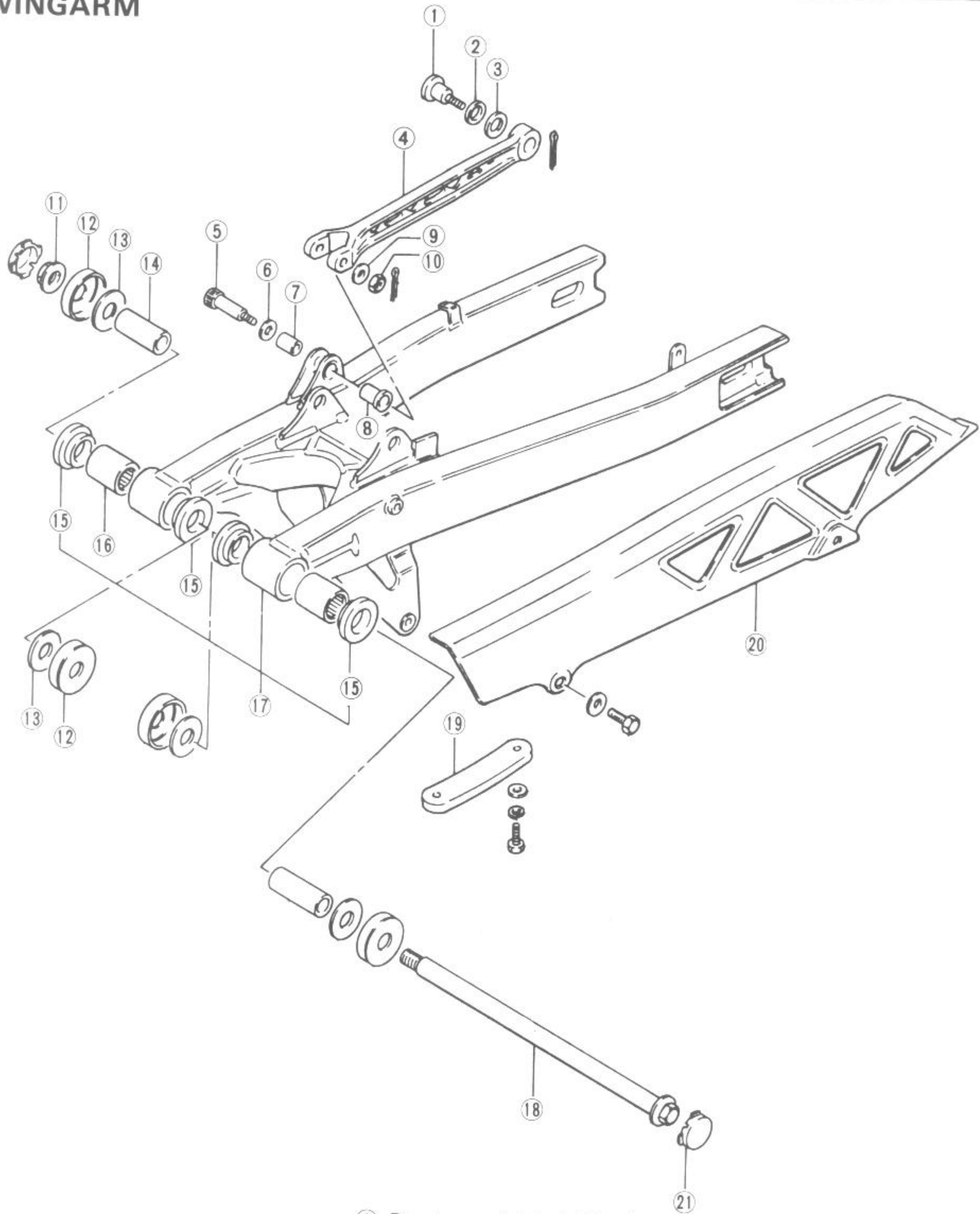

- ① Rear torque link bolt (Rear)
- ② Washer
- ③ Damper
- ④ Rear torque link
- ⑤ Rear torque link bolt (Front)
- ⑥ Washer
- ⑦ Spacer
- ⑧ Spacer
- ⑨ Washer
- ⑩ Torque link nut
- ⑪ Rear swingarm pivot shaft nut
- ⑫ Dust cover
- ⑬ Washer
- ⑭ Spacer
- ⑮ Spacer
- ⑯ Swingarm bearing
- ⑰ Swingarm
- ⑱ Swingarm pivot shaft
- ⑲ Chain buffer
- ⑳ Chain guard
- ㉑ Pivot shaft cap

Tightening torque		
Item	N·m	kg·m
⑩	10 - 15	1.0 - 1.5
⑪	50 - 80	5.0 - 8.0

REAR SHOCK ABSORBER

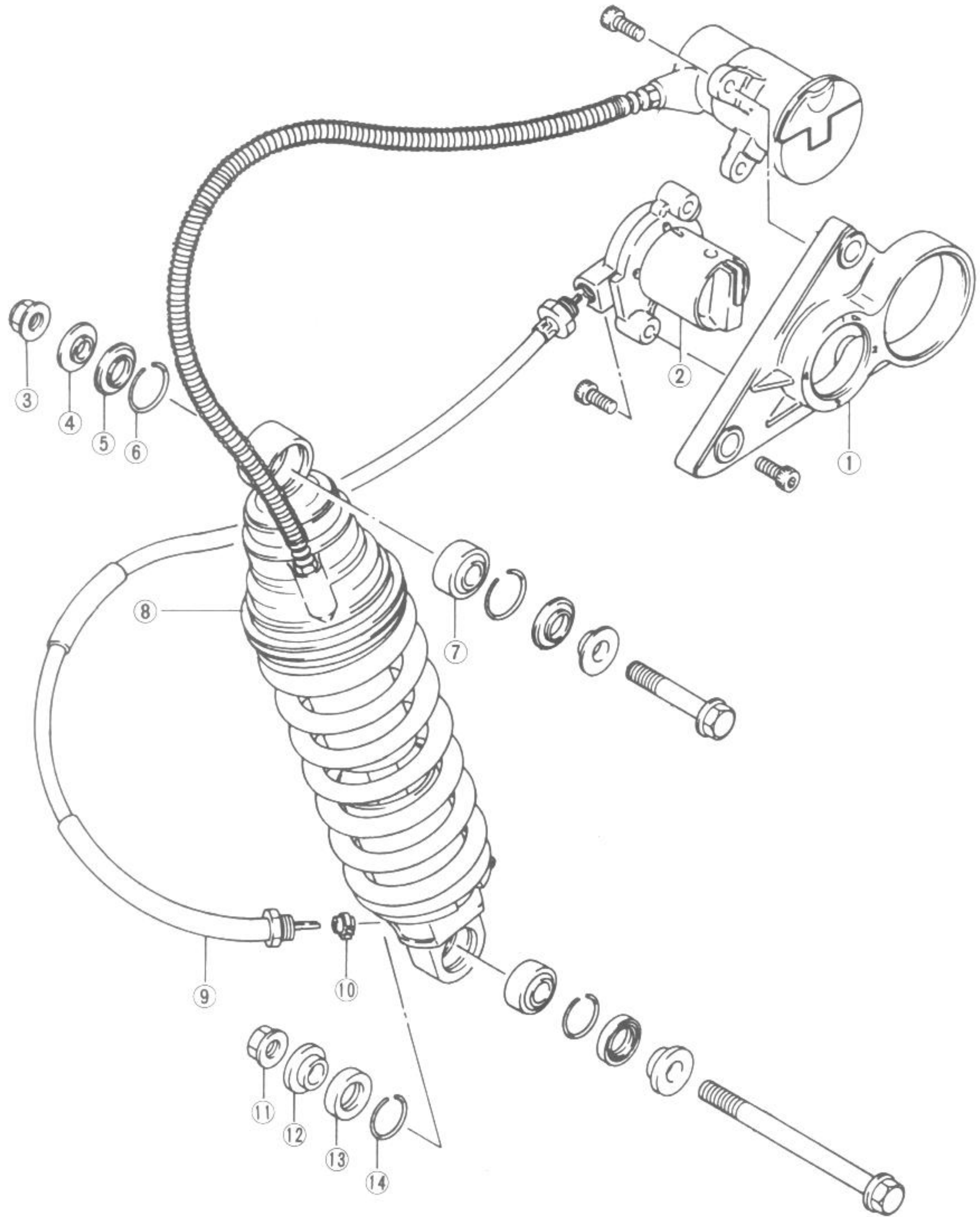

- ① Holder
- ② Remote damping adjuster
- ③ Shock absorber upper nut
- ④ Spacer
- ⑤ Dust seal
- ⑥ Circlip
- ⑦ Spherical ball bearing
- ⑧ Rear shock absorber unit
- ⑨ Damping adjuster cable
- ⑩ Adjuster drive gear
- ⑪ Rear shock absorber lower nut
- ⑫ Spacer
- ⑬ Dust seal
- ⑭ Circlip

Tightening torque		
Item	N·m	kg-m
③ , ⑪	48 - 72	4.8 - 7.2

CUSHION ROD, LEVER AND BRACKET

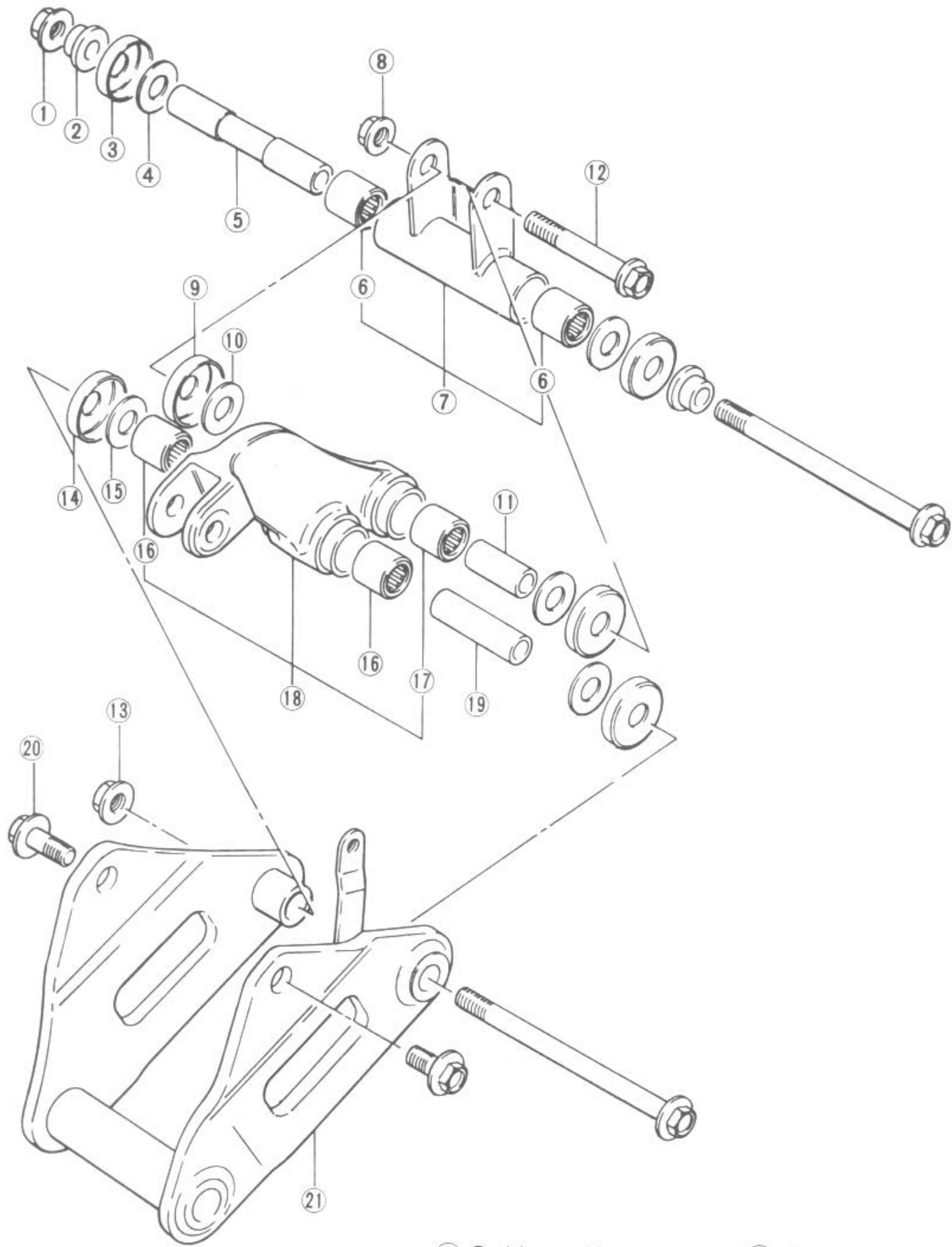

- ① Cushion rod lower nut
- ② Swingarm spacer
- ③ Dust cover
- ④ Washer
- ⑤ Spacer
- ⑥ Cushion rod bearing
- ⑦ Cushion rod
- ⑧ Cushion rod upper nut
- ⑨ Dust cover
- ⑩ Washer
- ⑪ Spacer
- ⑫ Cushion rod upper bolt
- ⑬ Cushion lever shaft nut
- ⑭ Dust cover
- ⑮ Washer
- ⑯ Cushion lever bearing
- ⑰ Cushion rod upper bearing
- ⑱ Cushion lever set
- ⑲ Cushion lever spacer
- ⑳ Bracket bolt
- ㉑ Bracket

Tightening torque		
Item	N·m	kg·m
①, ⑧, ⑬	84 - 100	8.4 - 10.0
⑳	70 - 100	7.0 - 10.0

REMOVAL AND DISASSEMBLY

- Remove the following items to remove the rear swing arm and related parts.
 - * Seat.
 - * Both frame covers.
 - * Rear wheel assembly.
 - * Rear brake caliper.
- Remove the remote spring adjuster bolts ① and damping force adjuster bolts ②.
- Remove the cushion lever shaft nut ③, and draw out the shaft.
- Remove the rear swing arm pivot shaft nut ④ and draw out the swing arm pivot shaft.
- Remove the swingarm assembly and rear shock absorber assembly.

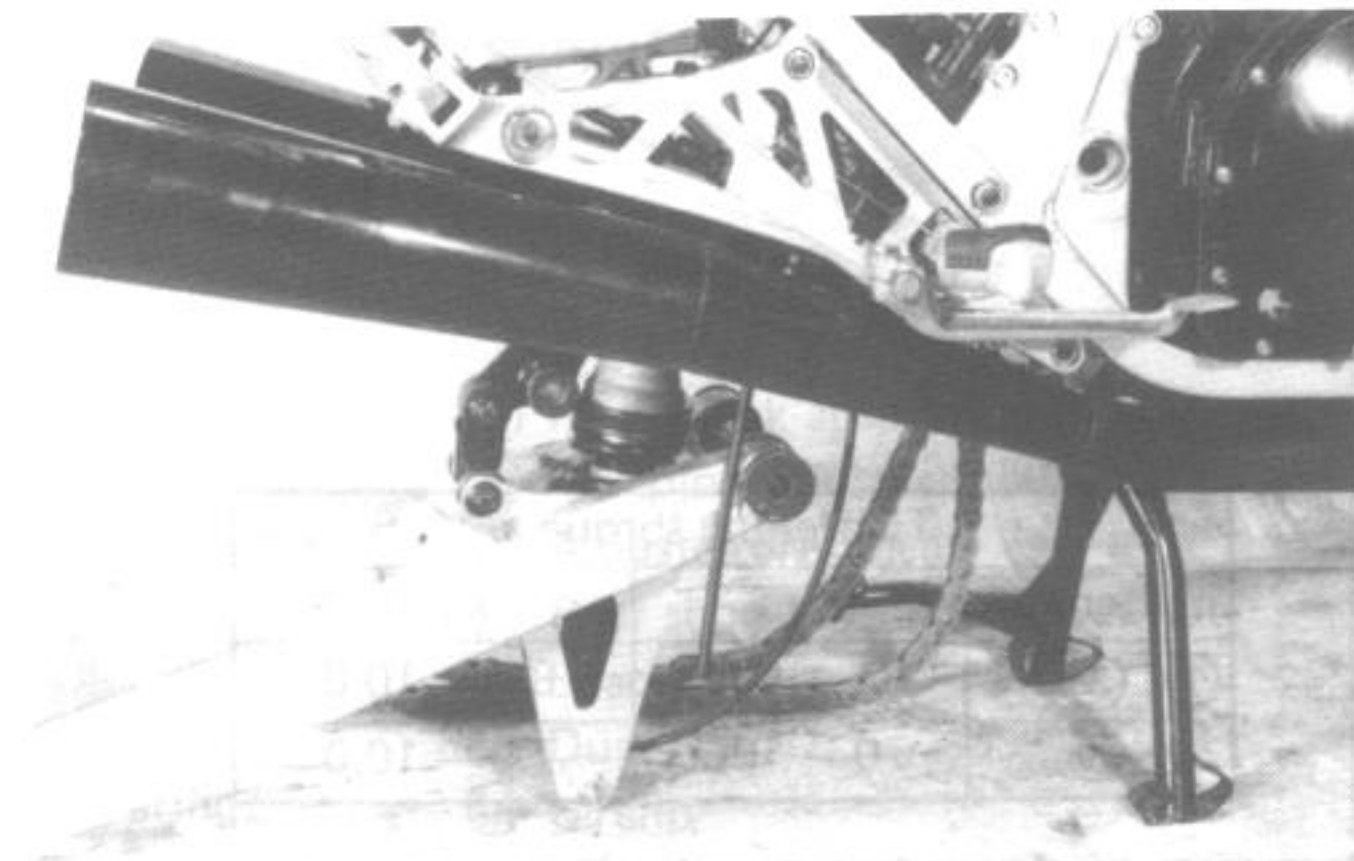
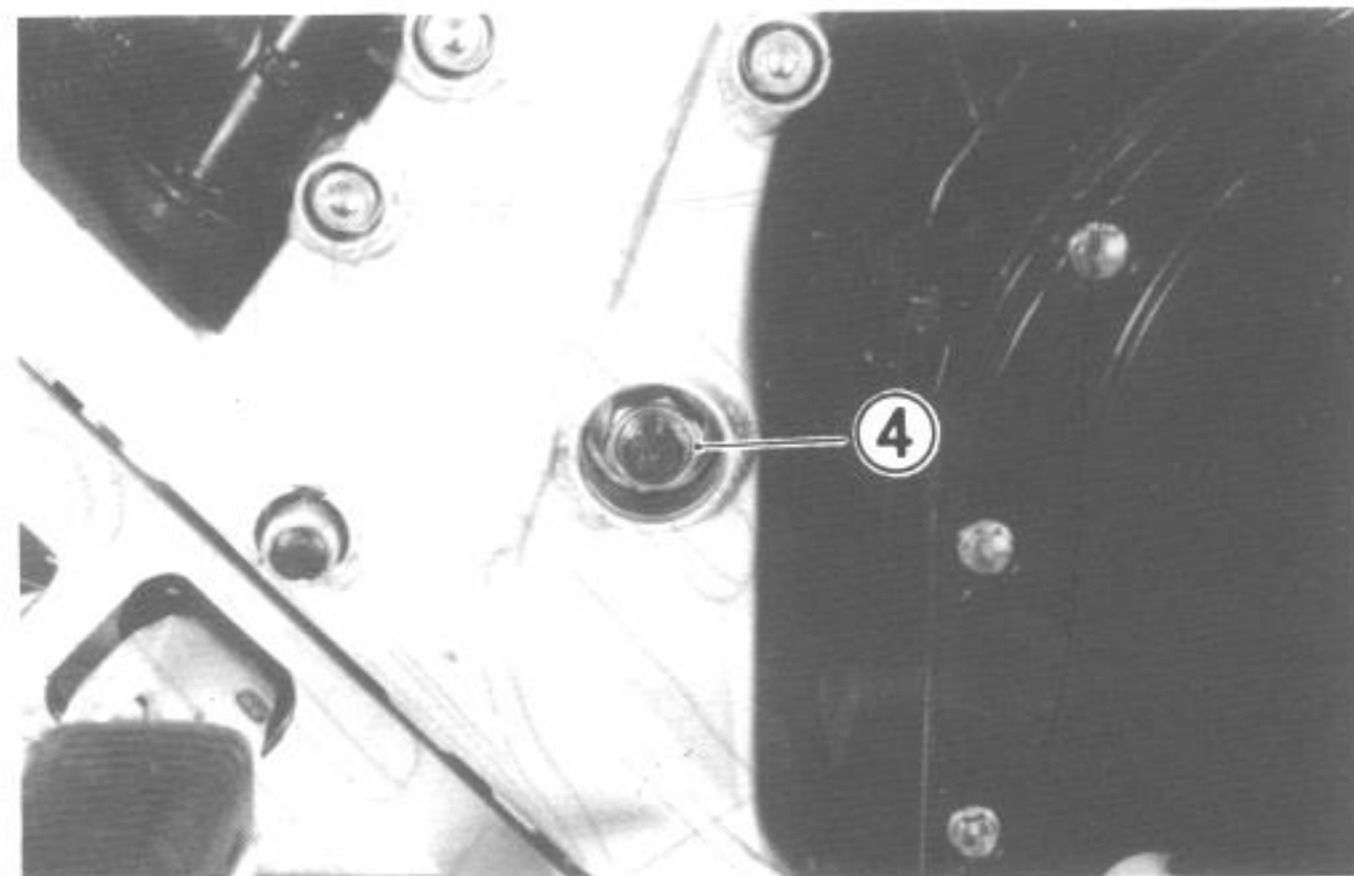
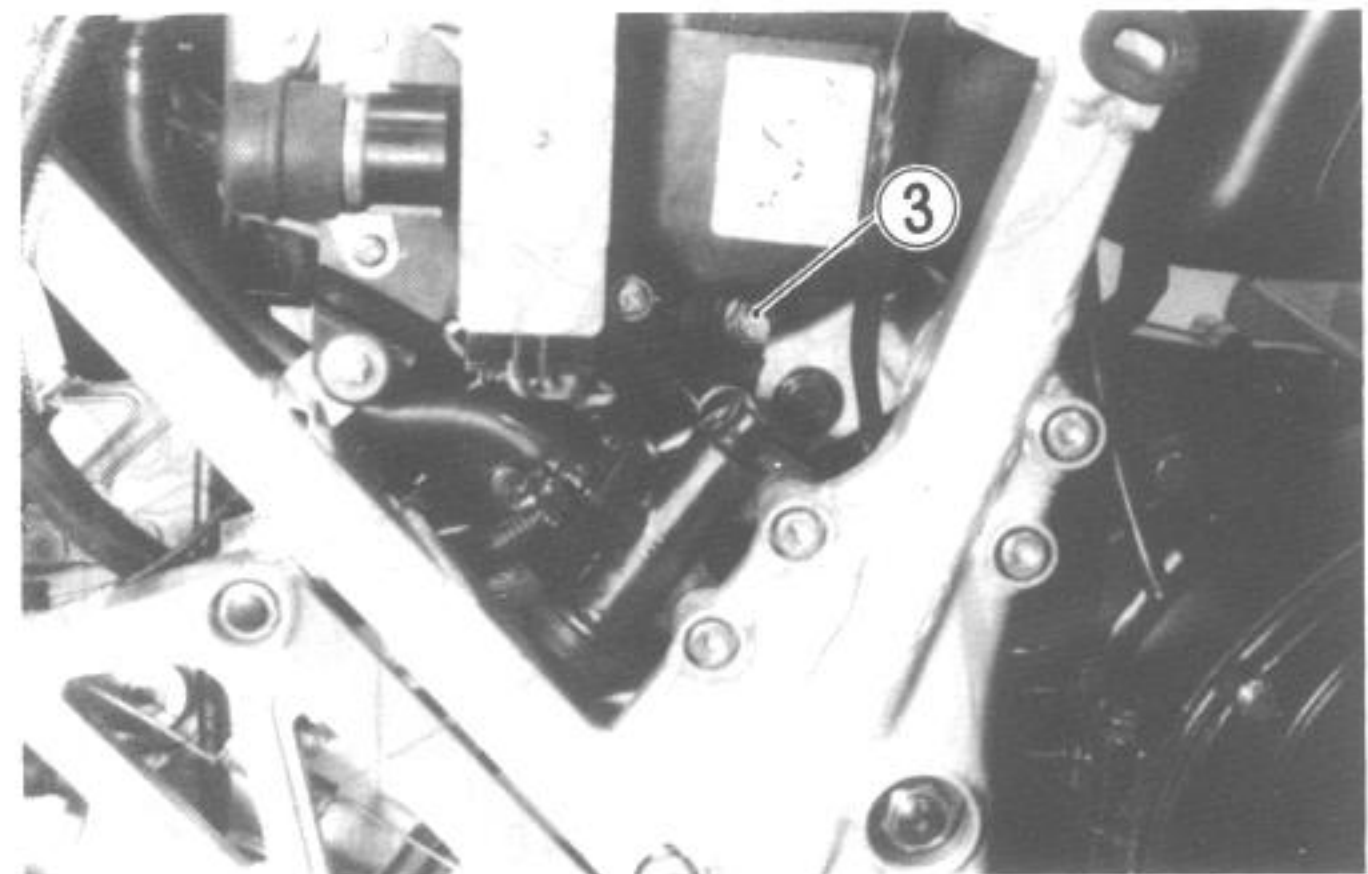
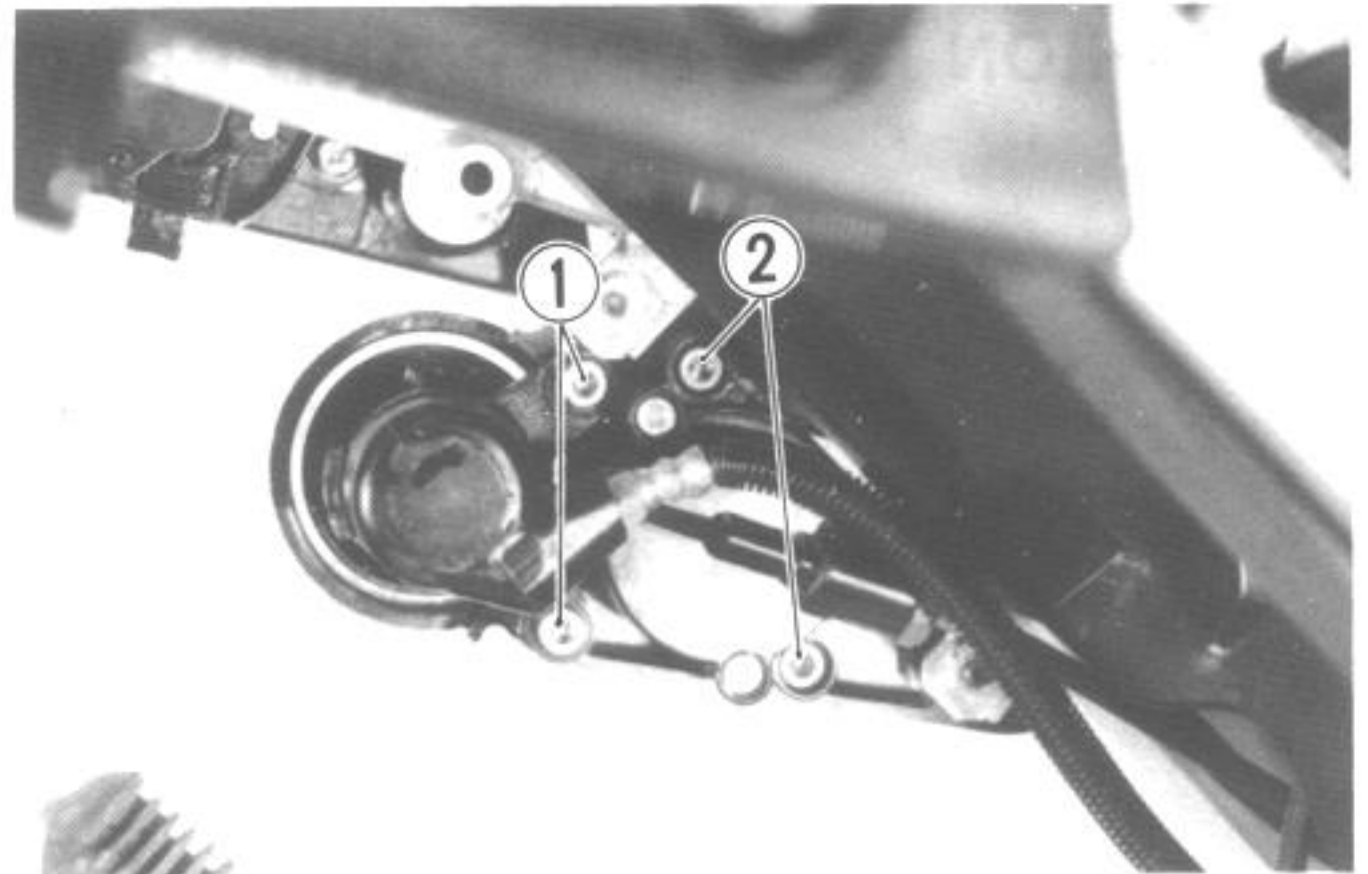

- Remove the rear shock absorber unit from the rear swingarm.

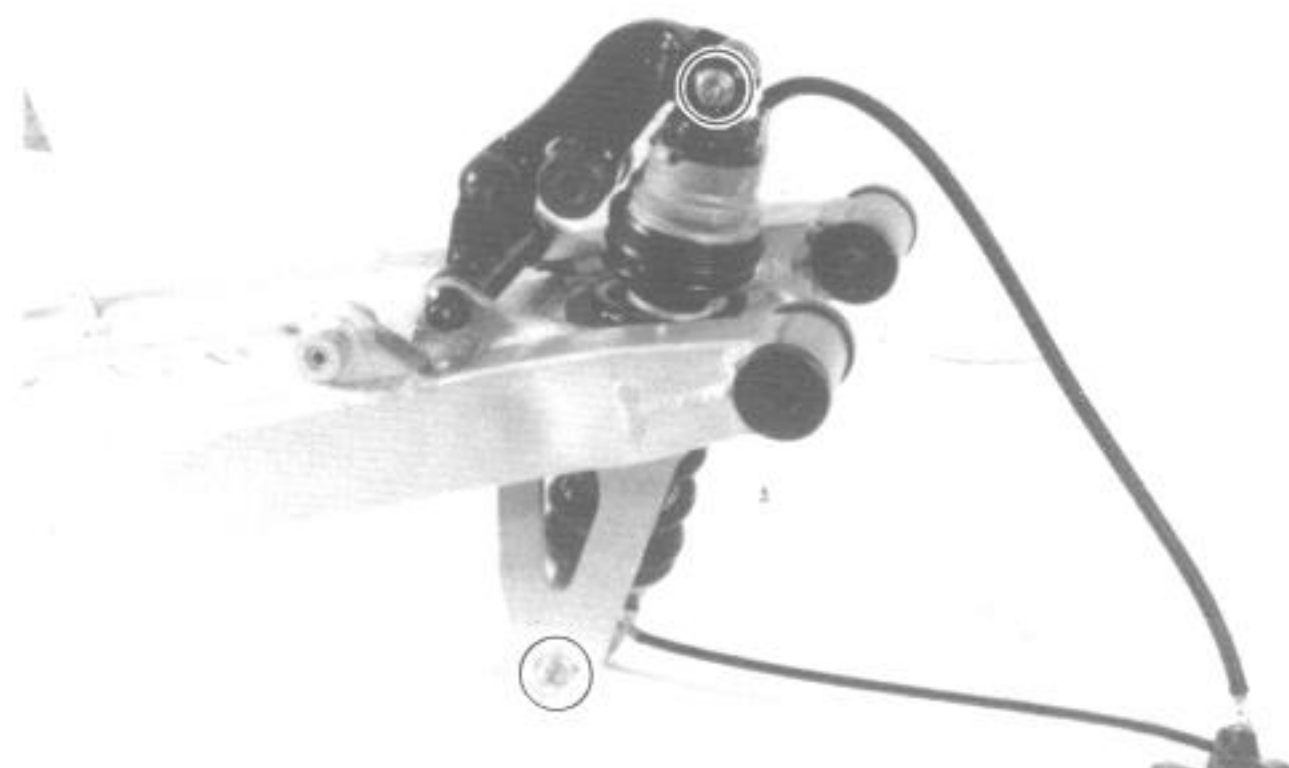

- Remove the cushion lever ① and cushion rod ② from the swingarm.

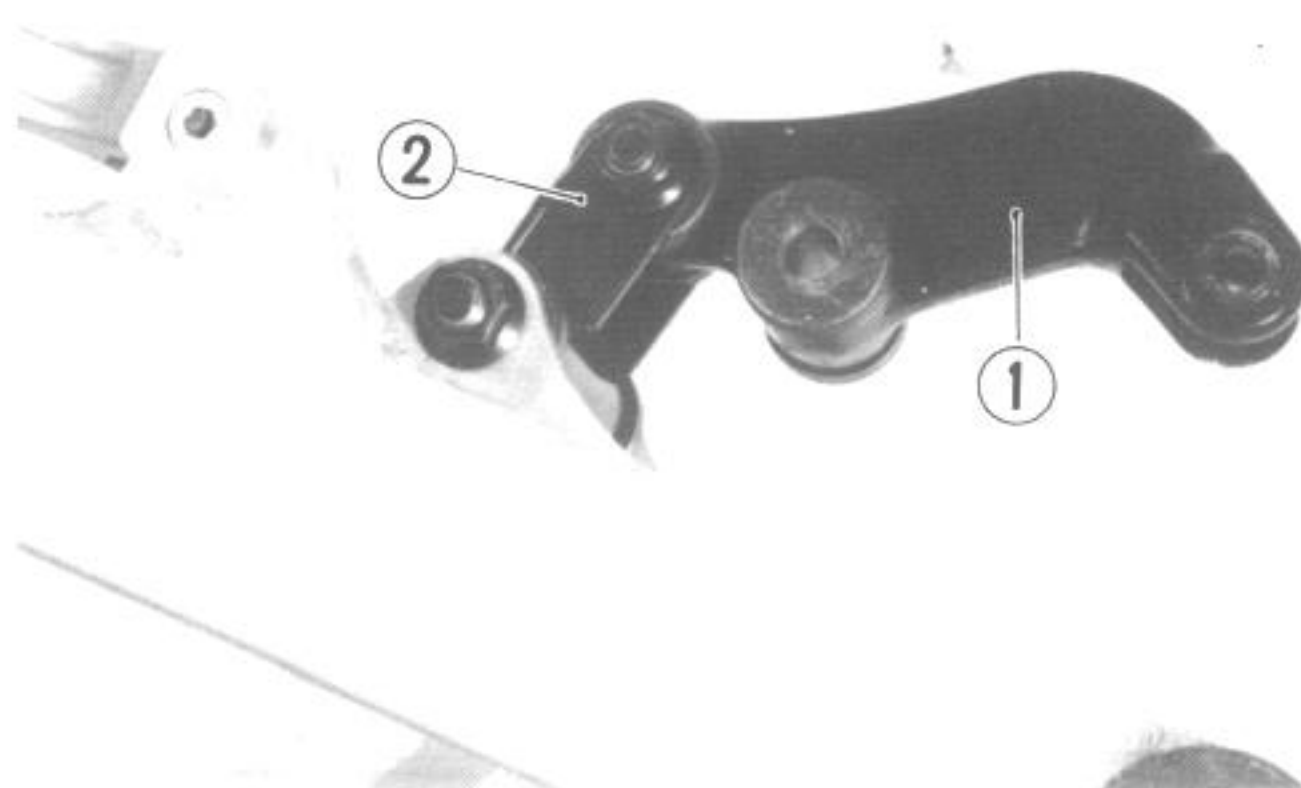

REAR SWINGARM

- Separate the dust seal covers, washers and spacers from the swing arm.

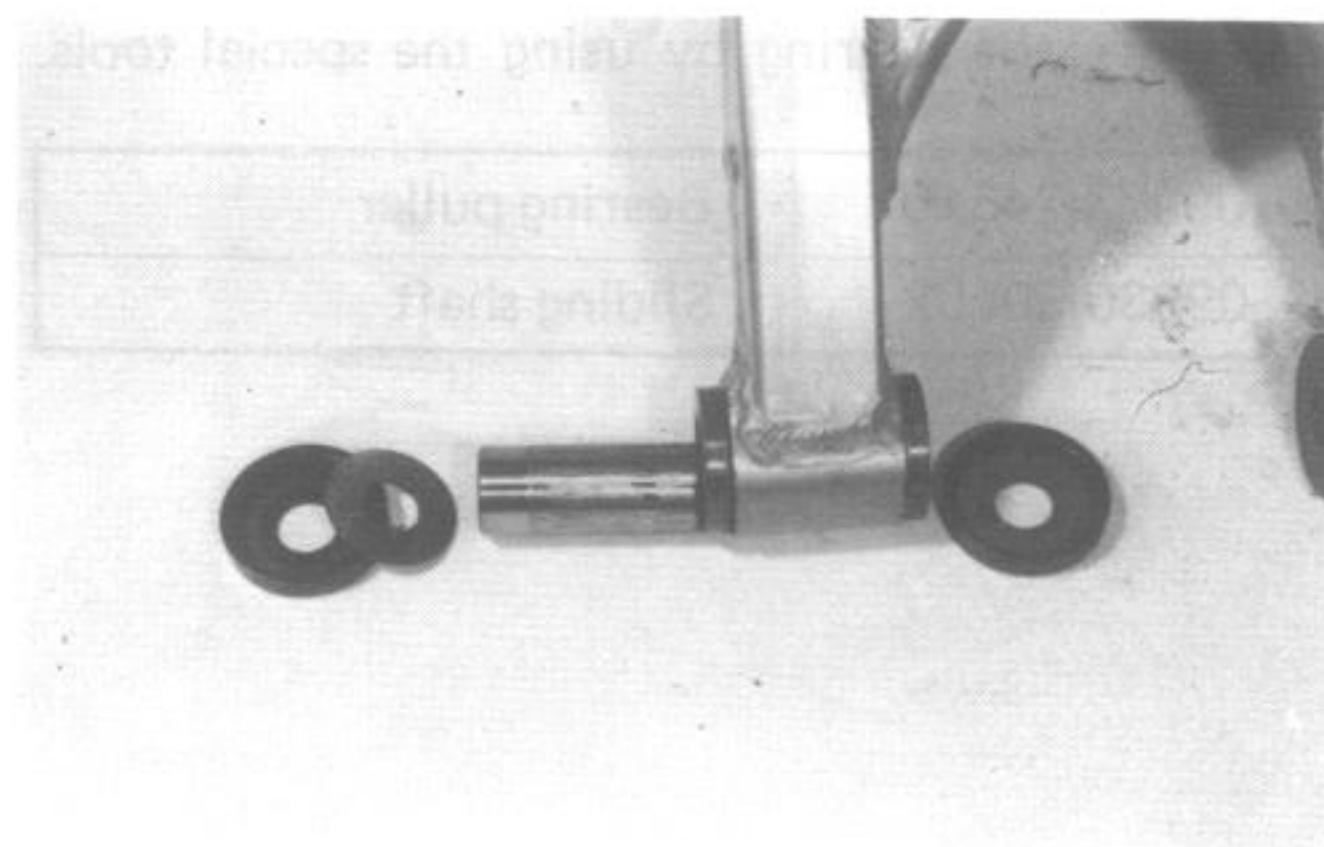

- Remove the bushings with screw driver.

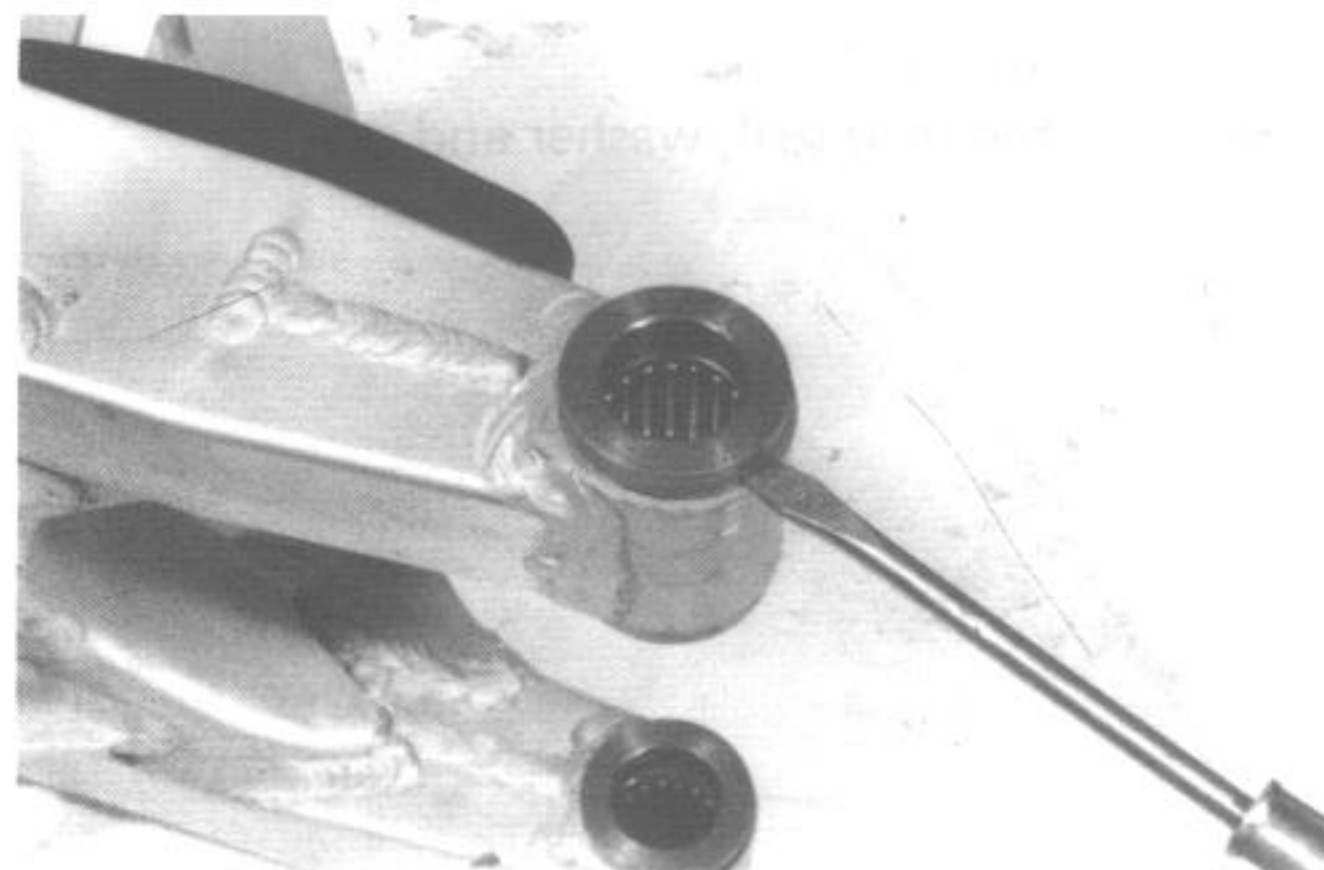

- Remove the swingarm bearing with a suitable drift.

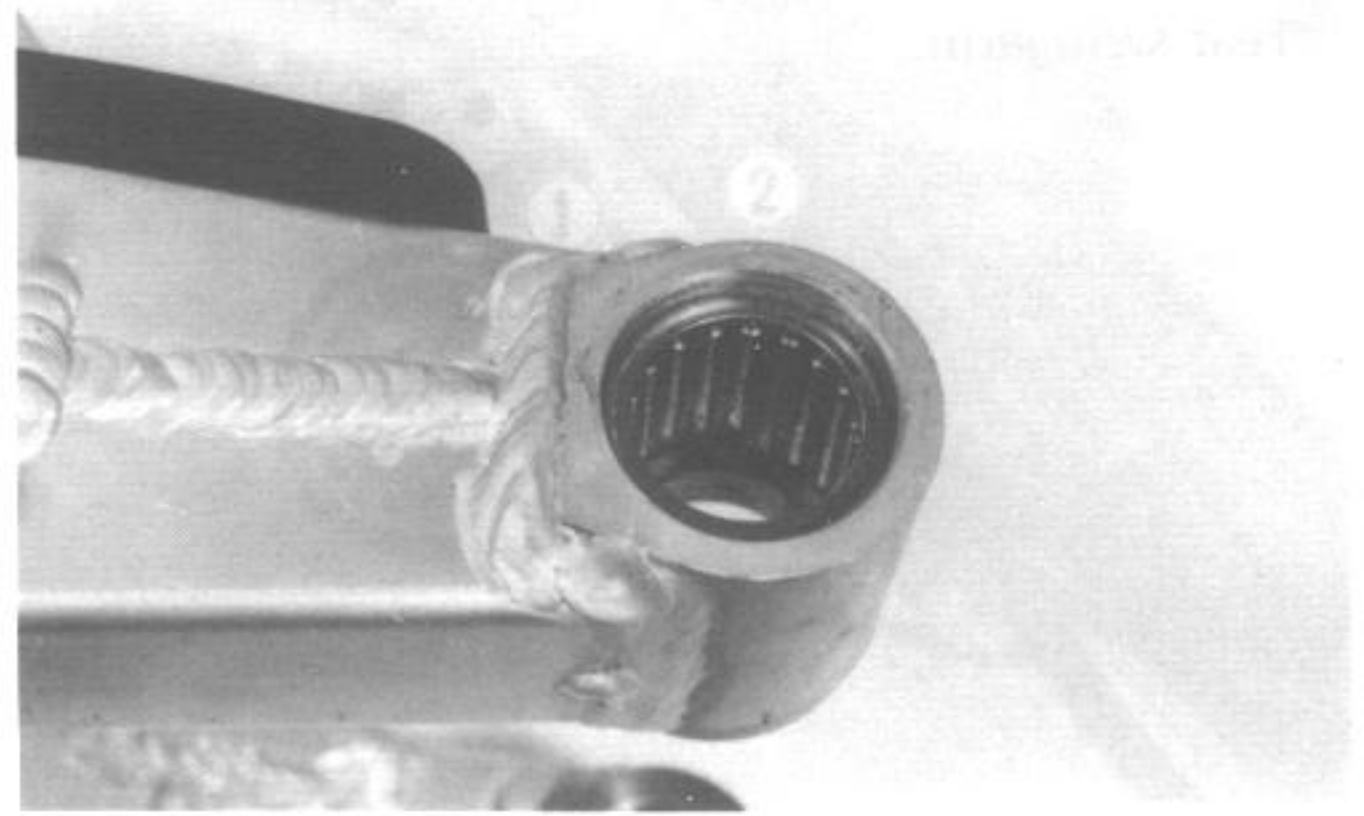

CUSHION ROD

- Remove the dust seal, washer and spacer.

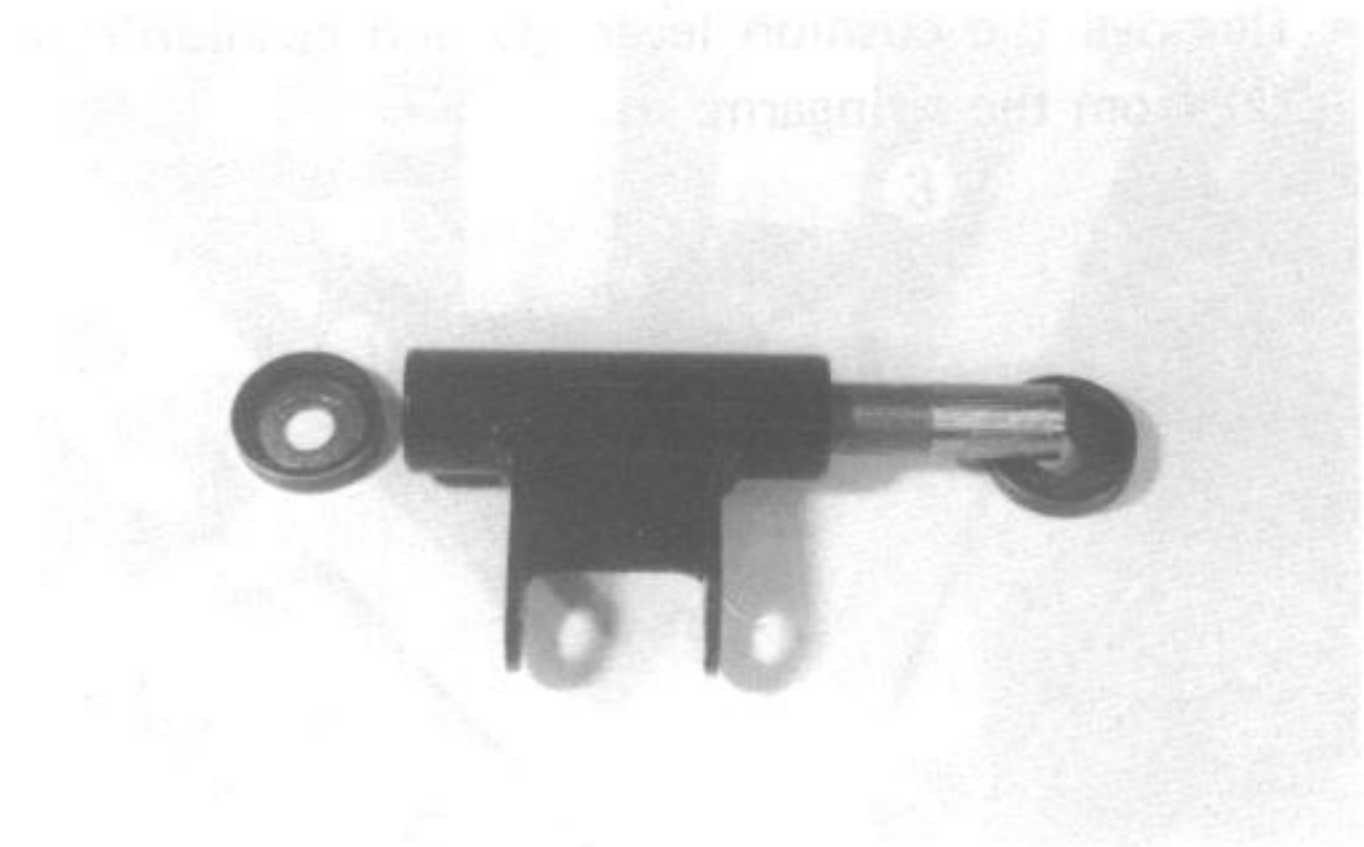

- Remove the bearing by using the special tools.

09923-74510	Bearing puller
09930-30102	Sliding shaft

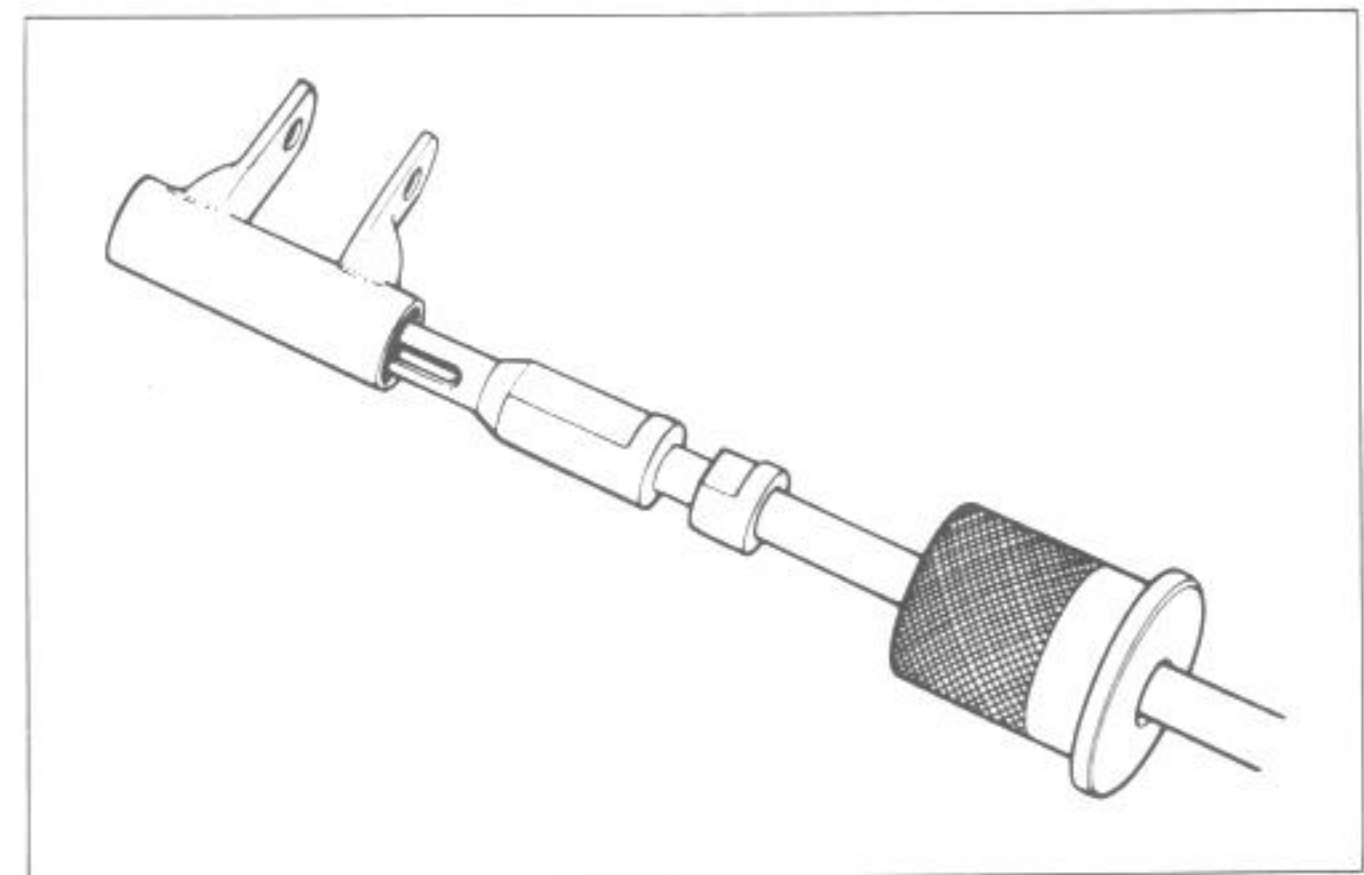

CUSHION LEVER

- Remove the dust seal, washer and spacer.

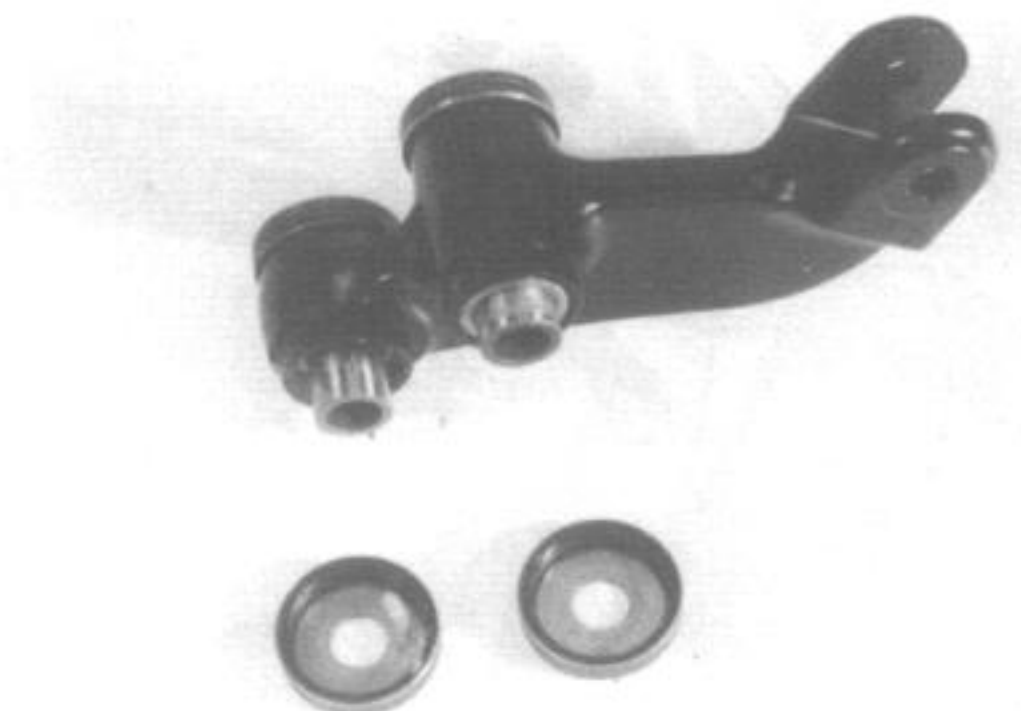

- Remove the bearing by using the special tools.

09923-74510	Bearing puller
09930-30102	Sliding shaft

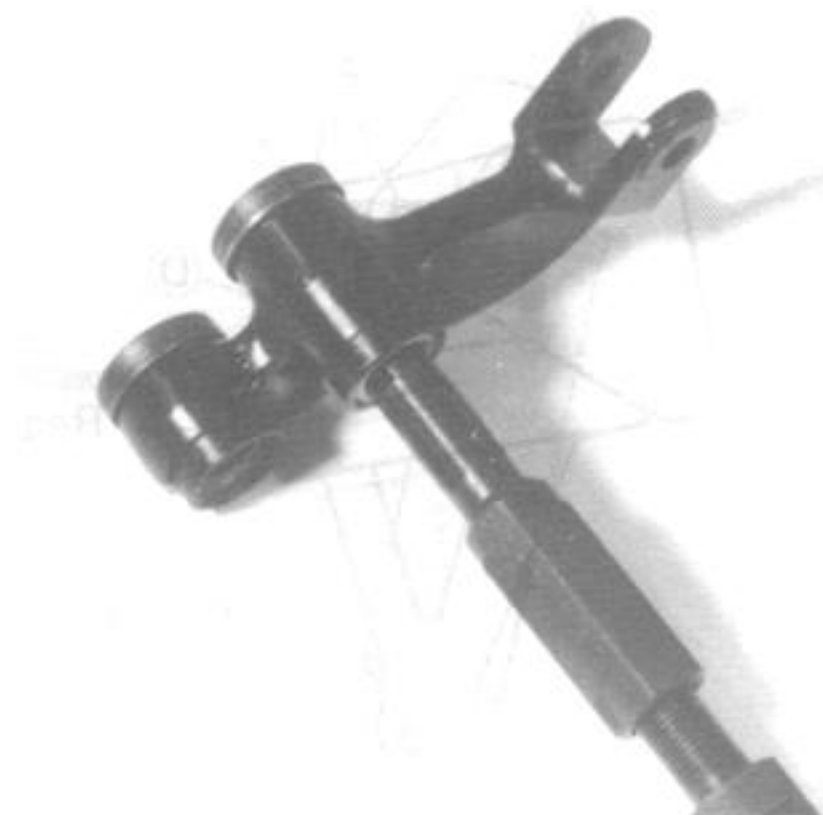

INSPECTION

SWINGARM PIVOT SHAFT

Using a dial gauge, check the pivot shaft for runout and replace it if the runout exceeds the limit.

09900-20606	Dial gauge (1/100)
-------------	--------------------

Service Limit	0.3 mm
---------------	--------

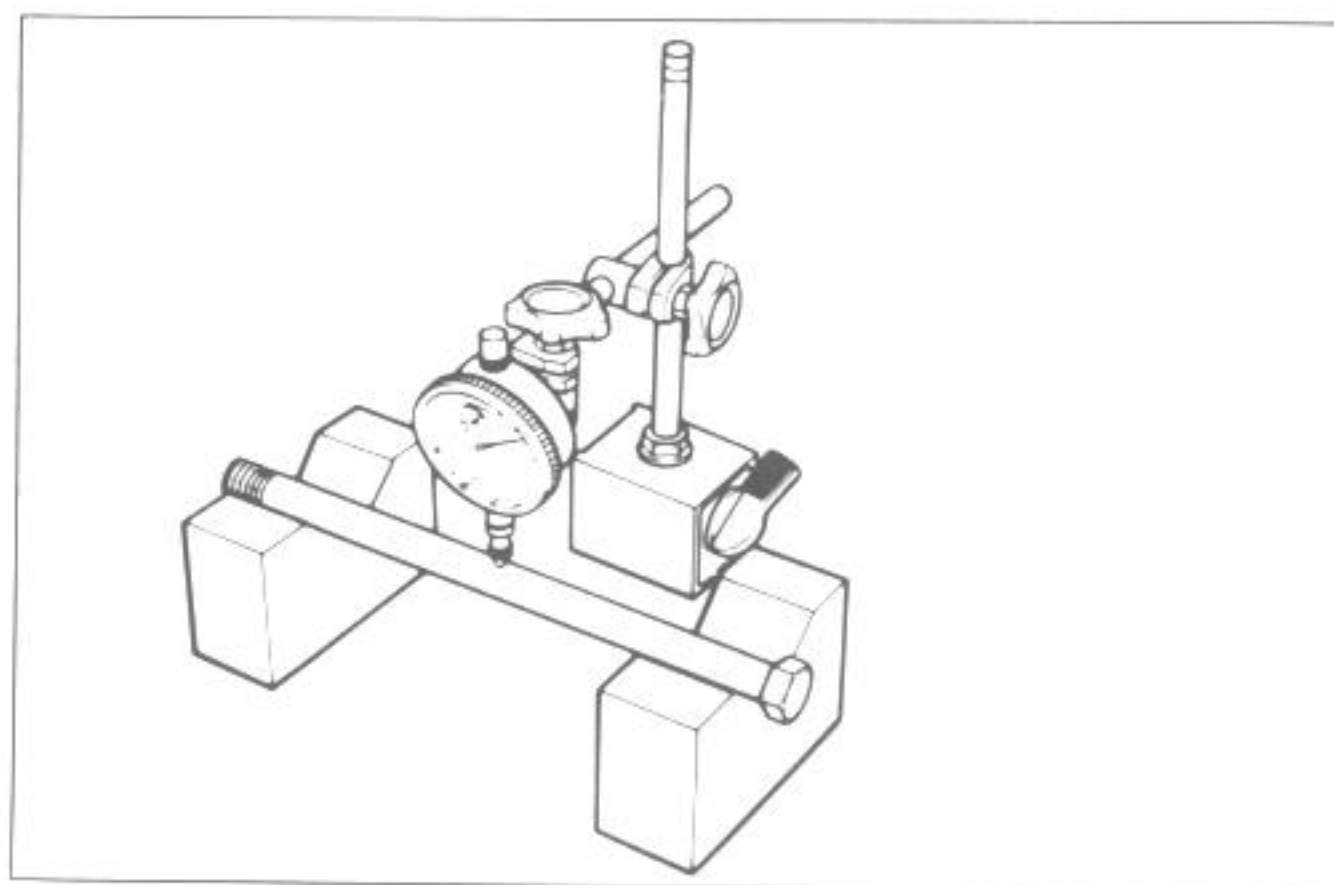

BEARINGS (NEEDLE ROLLER BEARING AND SPHERICAL BALL BEARINGS).

- Insert the spacer in the bearing and check the play by moving the spacer up and down. If an excessive play is noted, replace the bearing with a new one.
- Spherical ball bearings are located on upper and lower shock absorber. Insert the mounting bolt to the bearing and check the play by moving the bolt. If an excessive play is noted, replace the bearing with a new one.

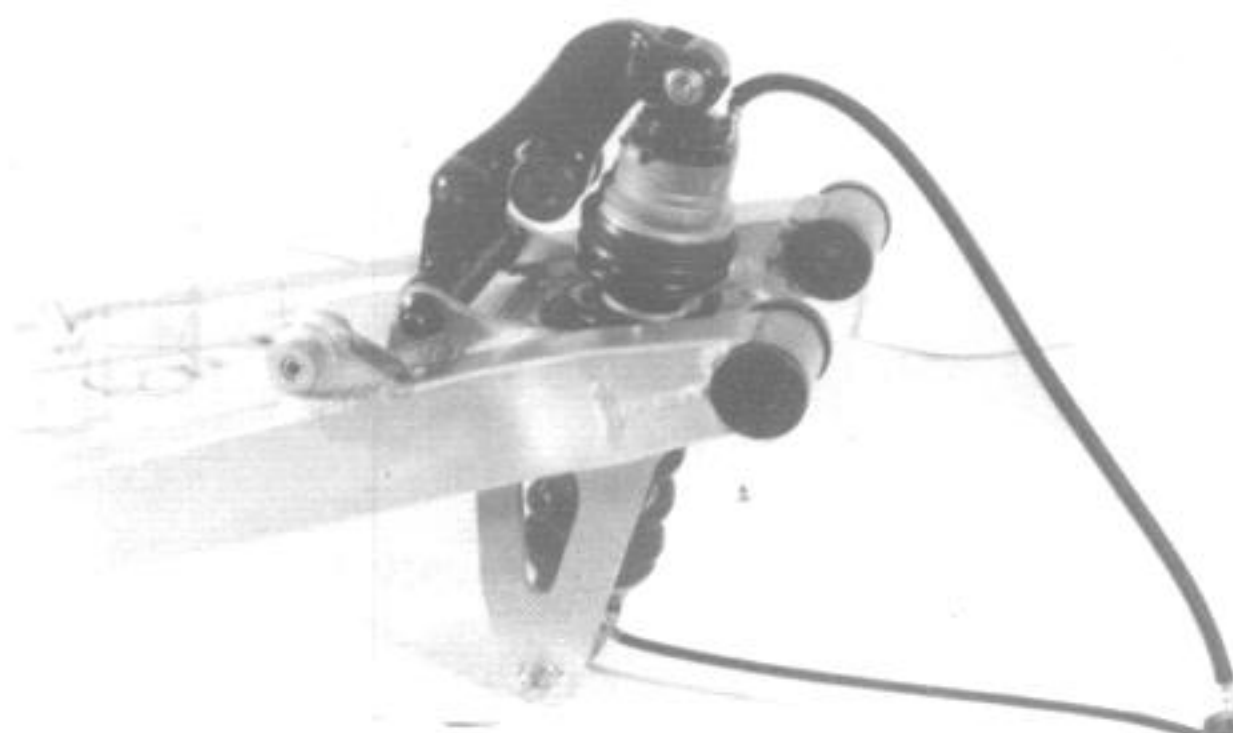
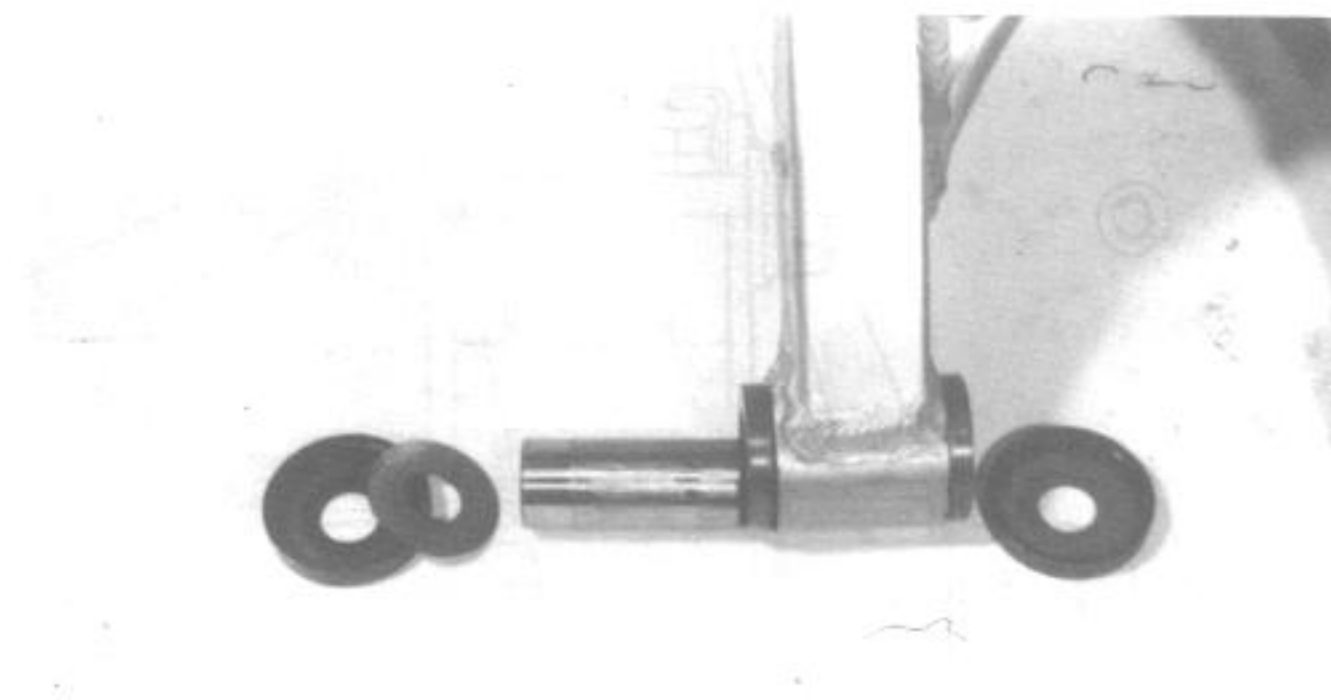

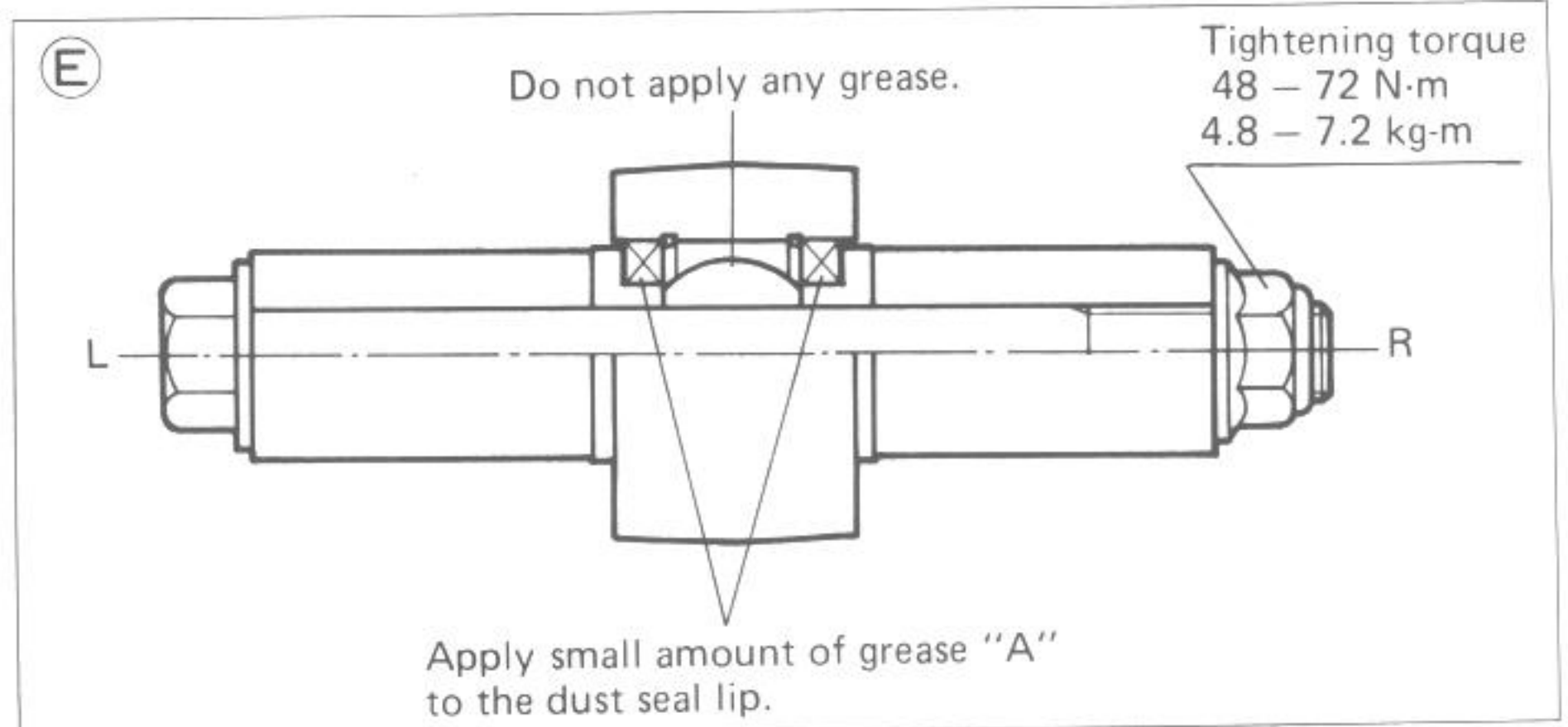
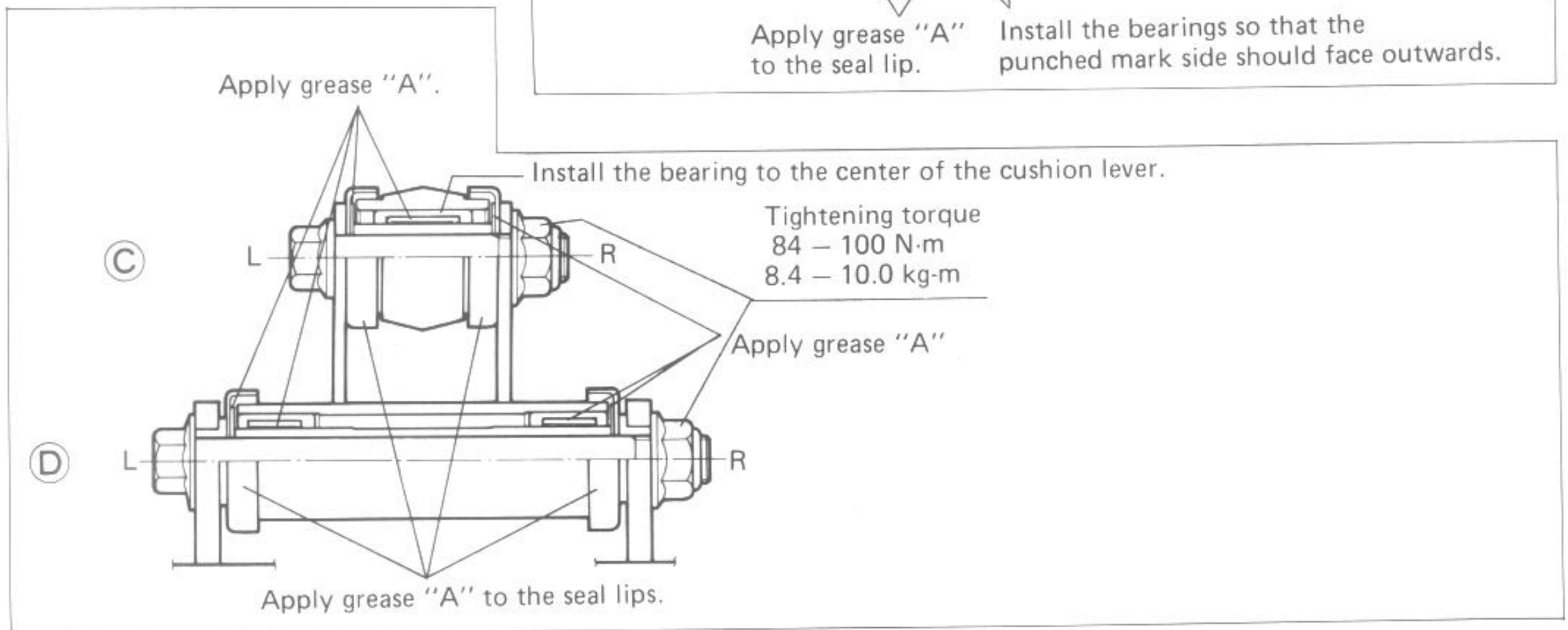
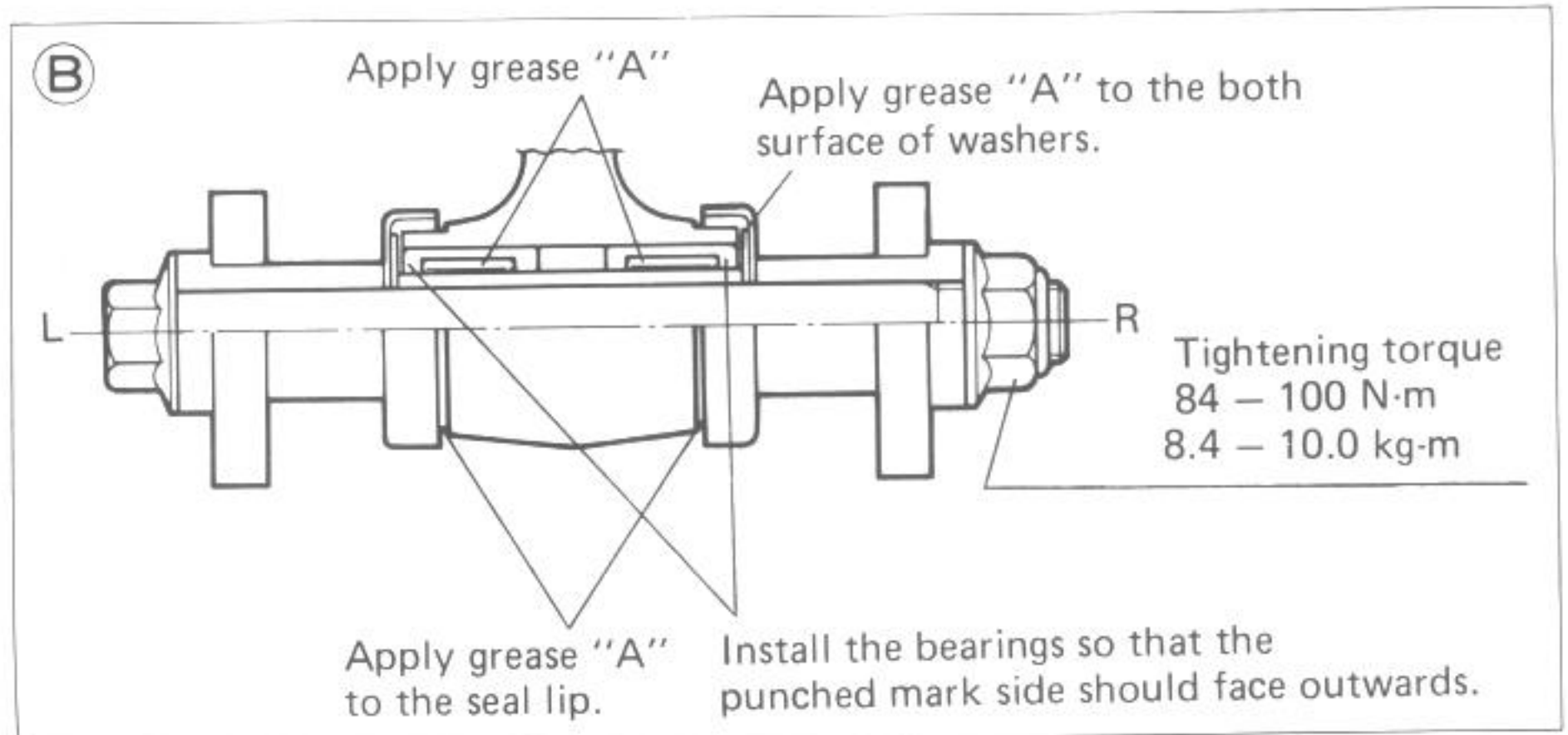
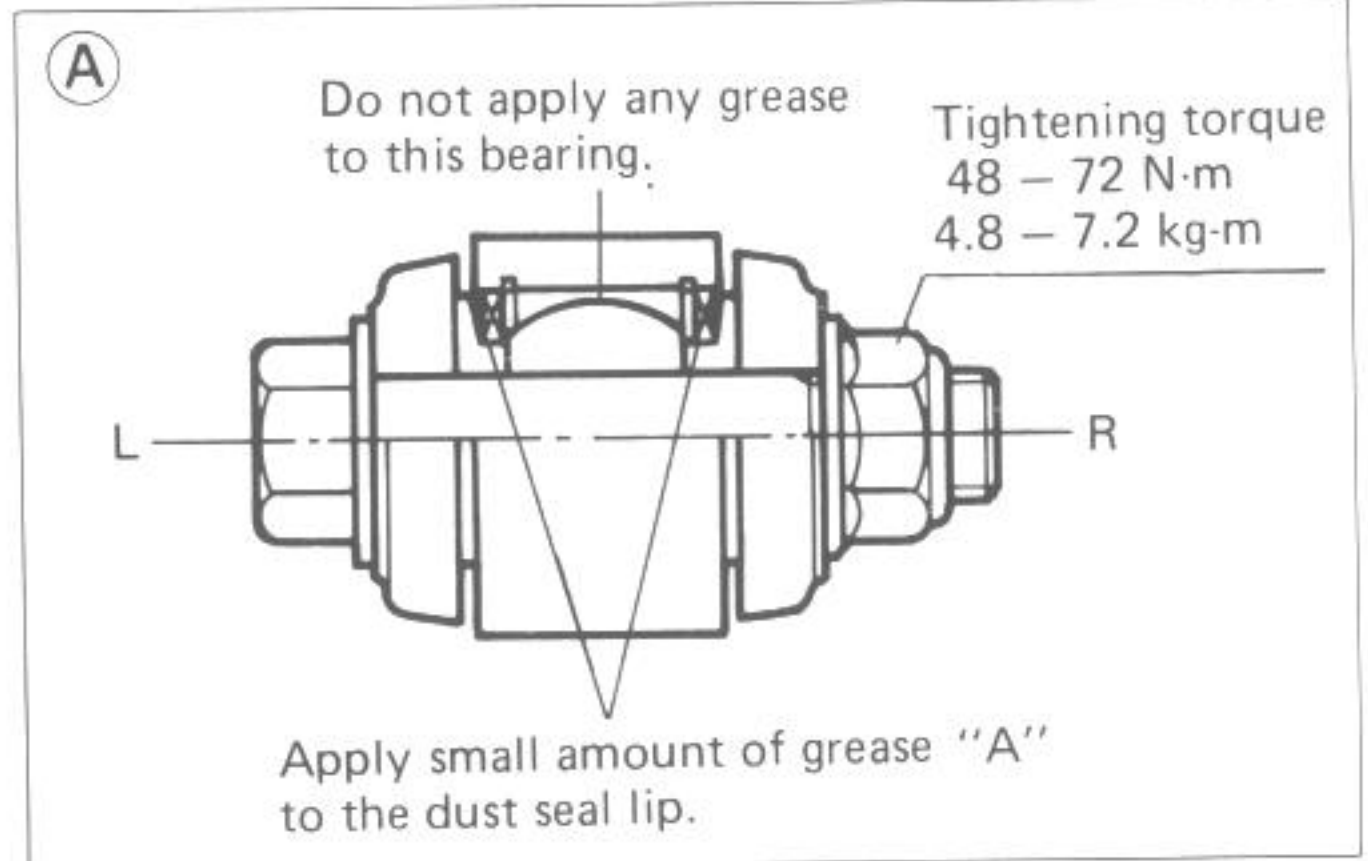
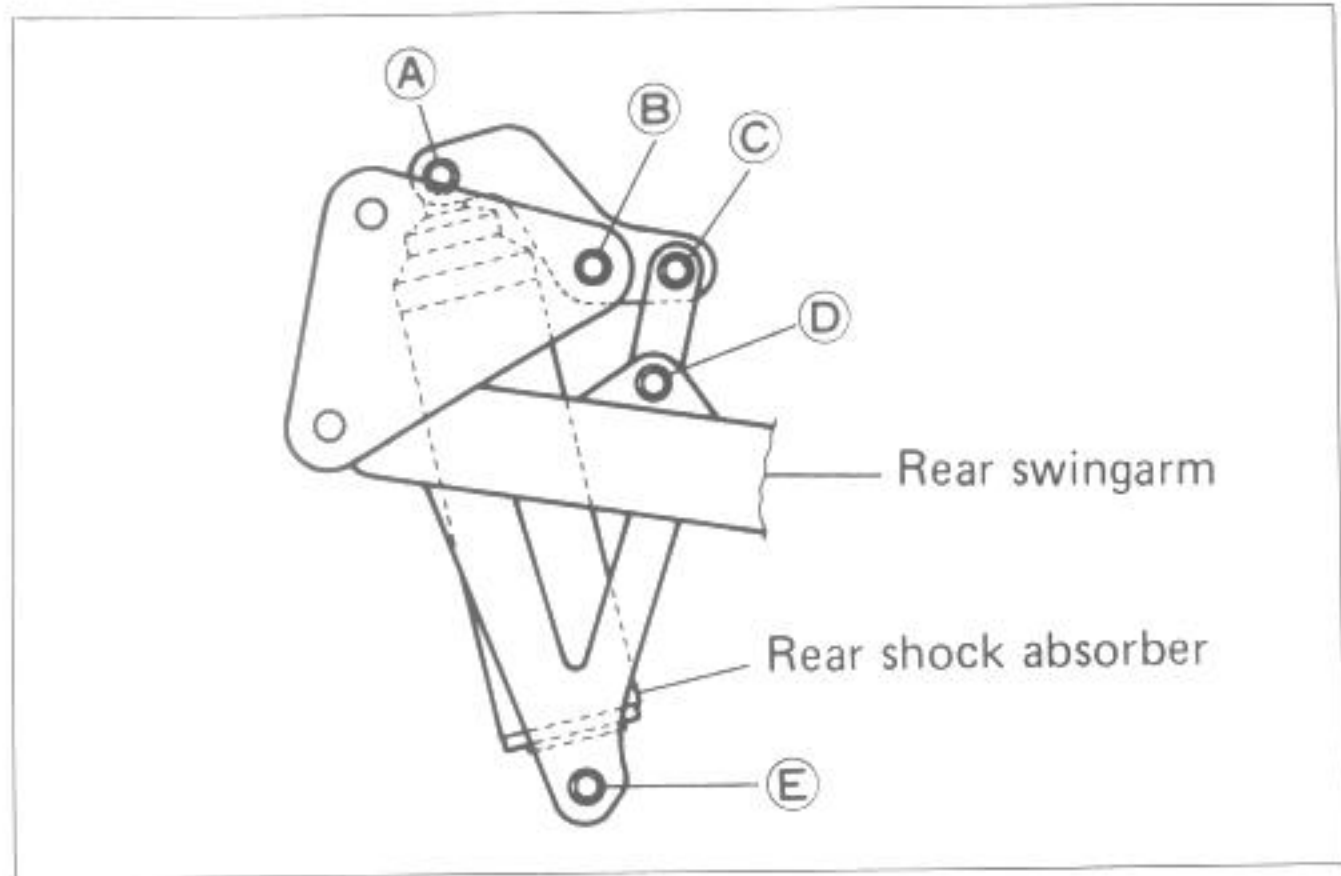

REAR SHOCK ABSORBER

- Inspect the rear shock absorber for any oil leakage by turning the adjuster knob clockwise or counter-clockwise. When turning the adjuster knob, check the rear shock absorber for smooth operation.

CAUTION:

Do not attempt to disassemble the rear shock absorber unit. It is not serviceable.

- Peel off the dust cover and inspect the ring position whether the ring turns properly when the remote damping adjuster knob turns.

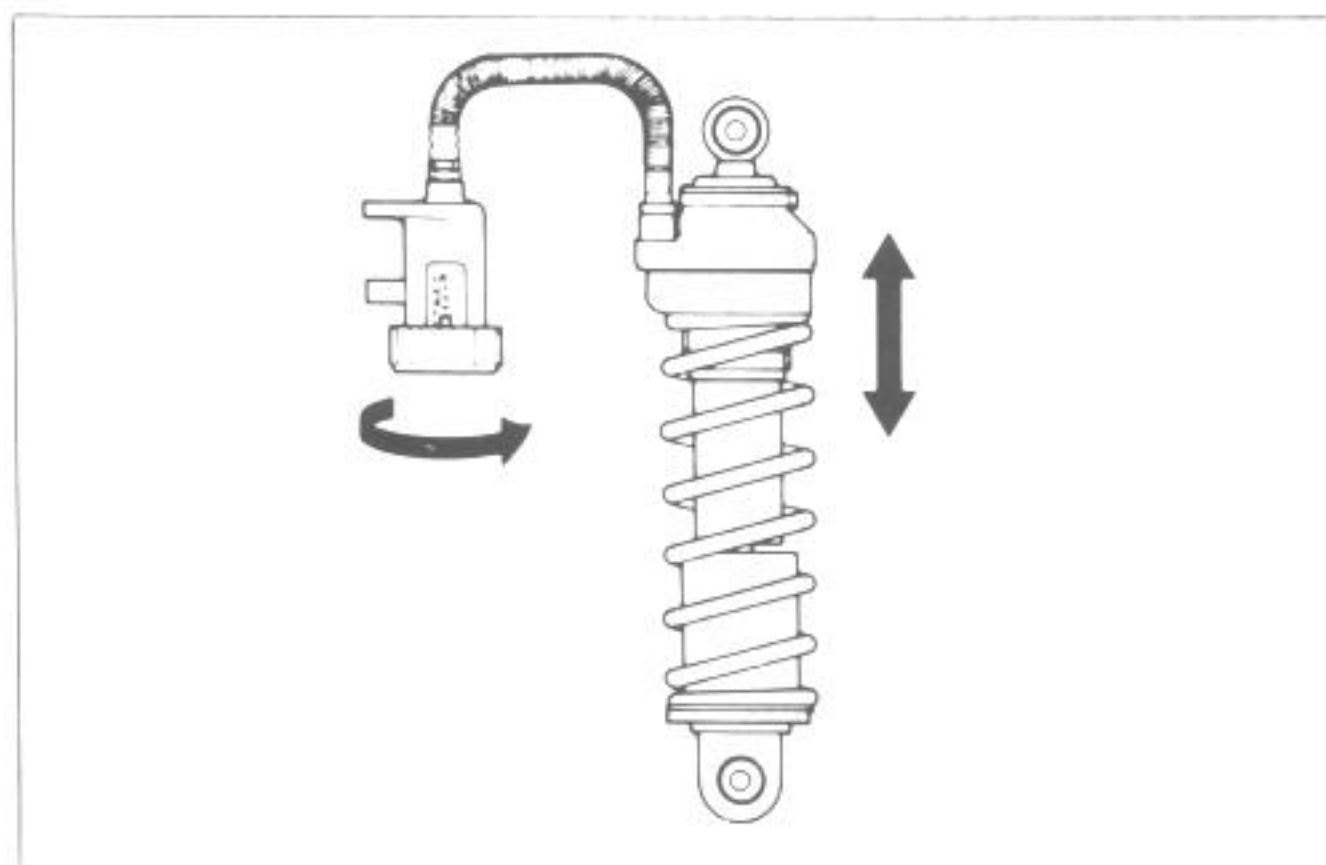

REASSEMBLY

Reassemble and remount the swingarm in the reverse order of disassembly and removal, and also carry out the following steps:

SWINGARM BEARINGS

Force-fit the bearings into the swingarm by using the special tool.

09924-84510

Bearing installer set

NOTE:

When installing two bearings, punch-marked side of bearing comes outside.



SPACER AND DUST SEAL COVER

Apply grease to the spacer and dust seal cover when installing them.

99000-25010

SUZUKI Super grease "A"

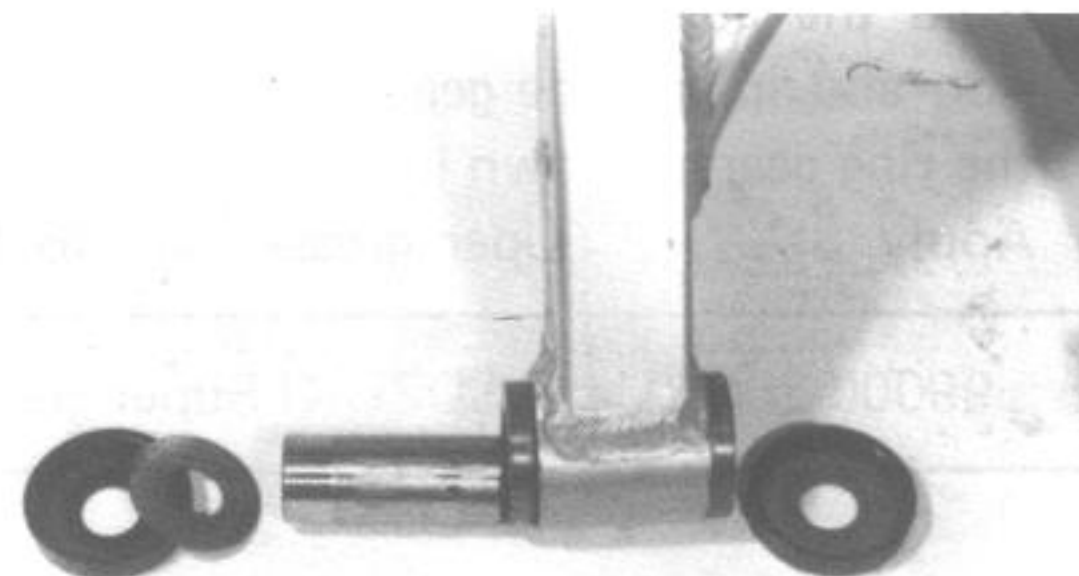

CUSHION ROD BEARINGS AND LEVER BEARINGS

Install the right and left bearings by using the special tool.

09941-34513

Bearing installer set

NOTE:

When installing the two bearings, punch-marked side of bearing faces outwards.

- Apply grease to the spacer and bearings.

99000-25010

SUZUKI Super grease "A"

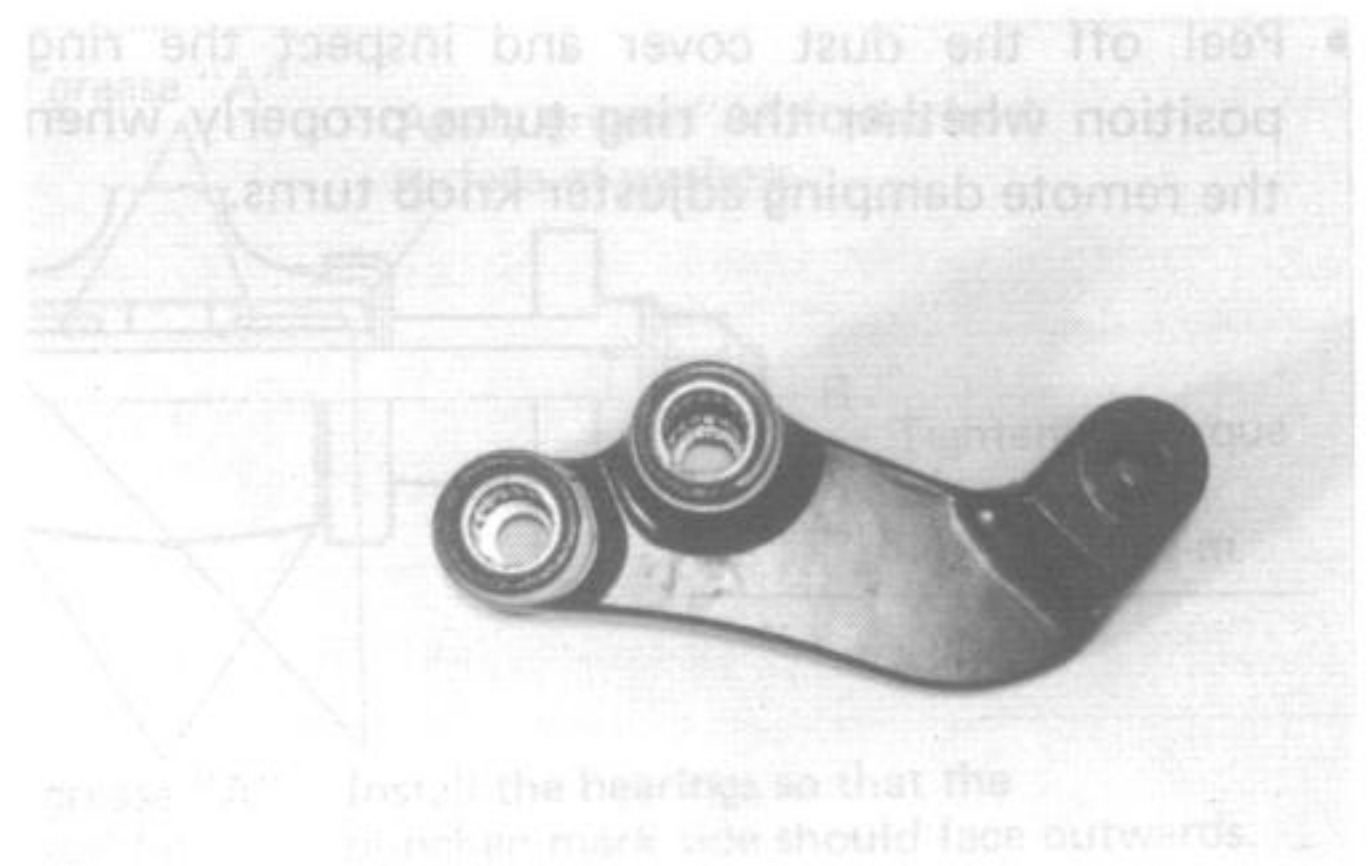
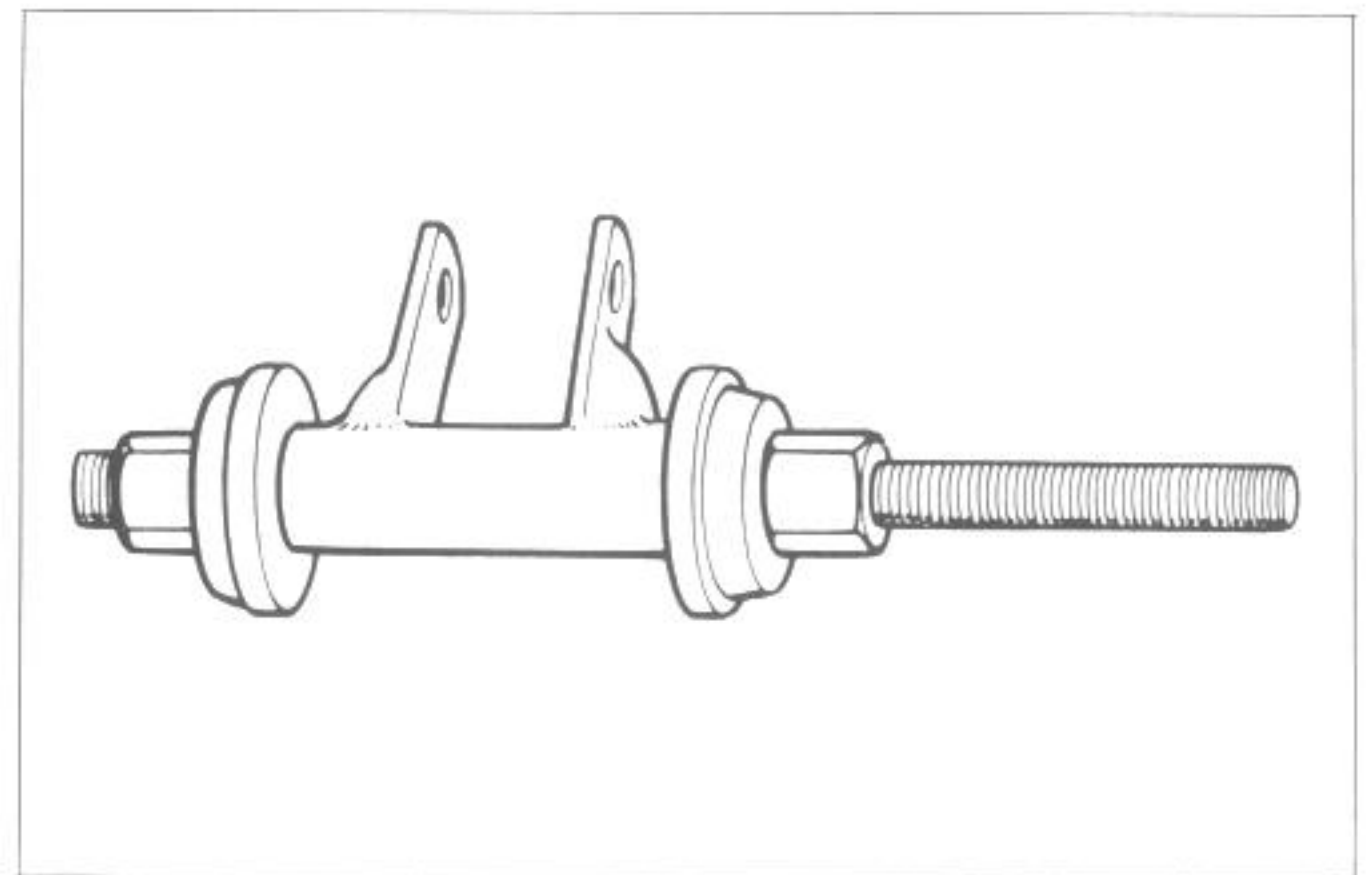

REAR SUSPENSION DAMPING FORCE ADJUSTER

- Take off the dust boot and turn the adjuster ring gear so that the aligning mark ① located between III and IIII on the adjuster ring gear aligns index mark ②.

- Hold the adjuster ring gear at the above position and install the gear to properly mesh with the ring gear as shown in the figure.
- Apply SUZUKI Super grease "A" to the gear.

99000-25010

SUZUKI Super grease "A"

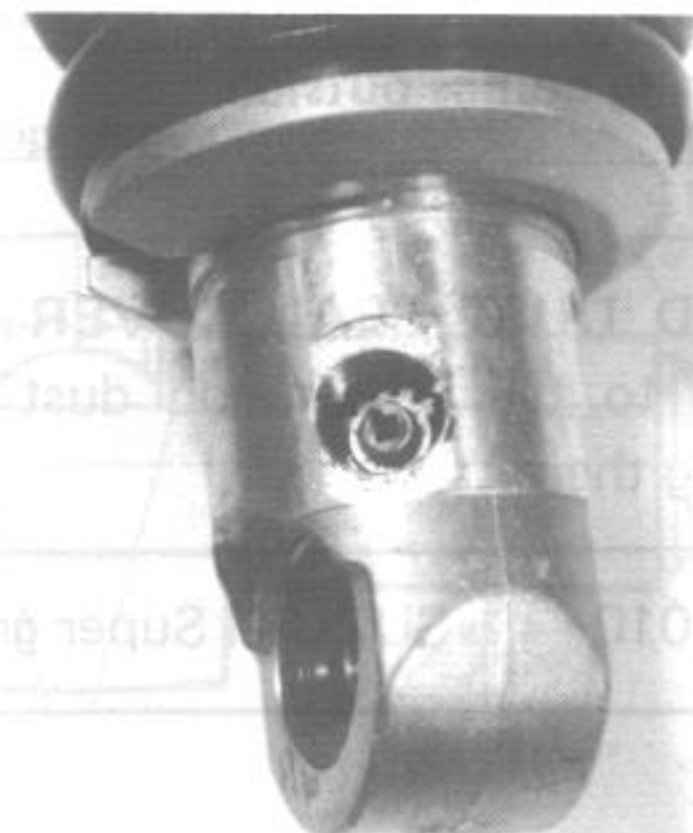

- Install the dust boot and remote control cable.
- Tighten the cable holder bolt to the specification.

Tightening torque	8 – 10 N·m (0.8 – 1.0 kg-m)
-------------------	--------------------------------

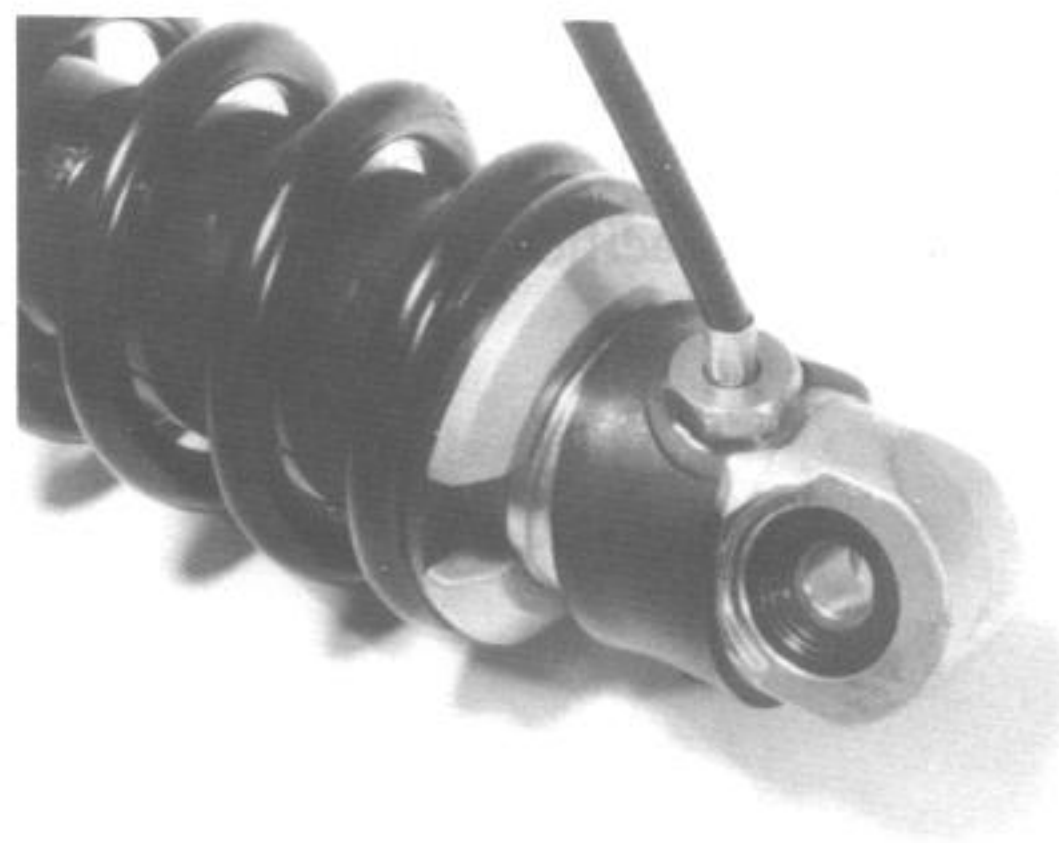

- Slide the spring on the ring gear shaft and apply grease to the teeth of gear.

99000-25010	SUZUKI Super grease "A"
-------------	-------------------------

- Align the hole ① with hole ② and install the ring gear to the knob with a screw.

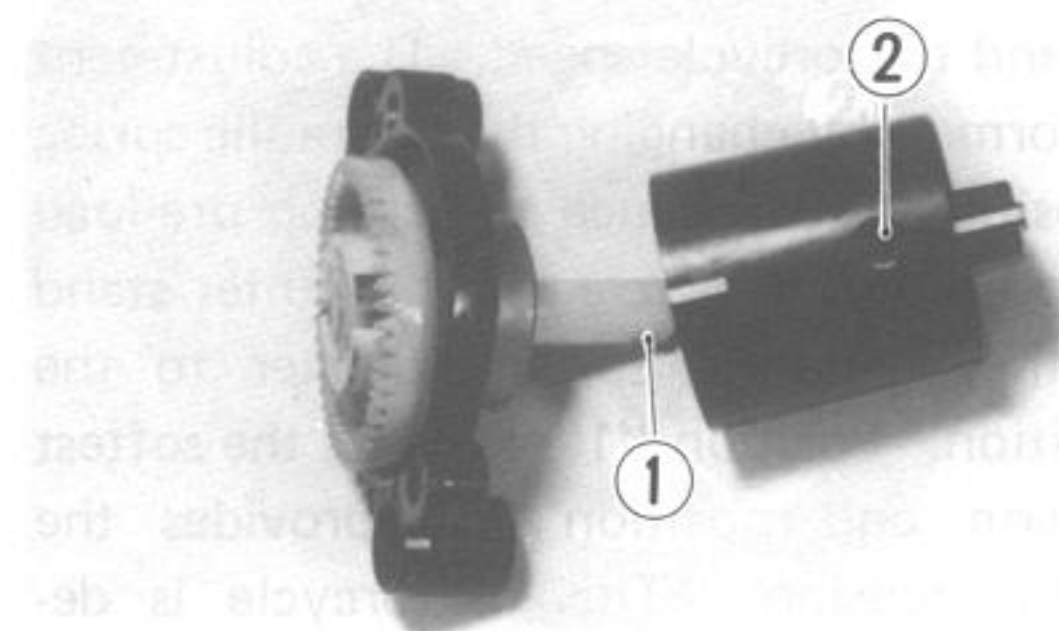

- Make sure that both marks, ① and ②, on the ring gear housing and on the knob should align each other when installing the knob to the ring gear.

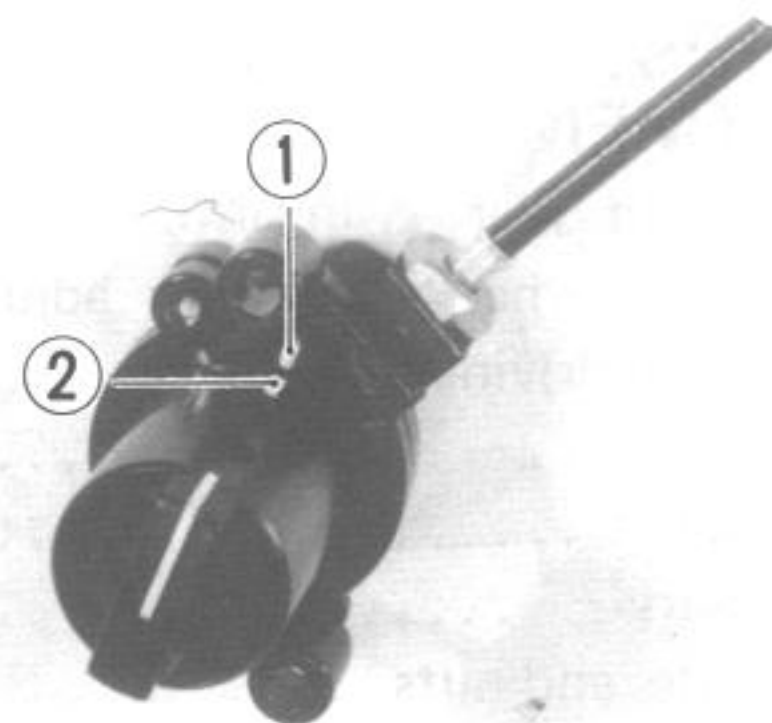

- While holding remote control cable and gear at the proper position, install the ring gear to the cable end gear.
- After assembling remote control unit, turn the remote control knob and check that the knob indicates the proper position against the ring gear indicator of the shock absorber unit.

Spring preload	Damping force	Remarks
3 (2)		Normal riding
3 (1)		Normal riding
4 (3)		Normal riding
4 (3)		Normal riding

0.3 kg

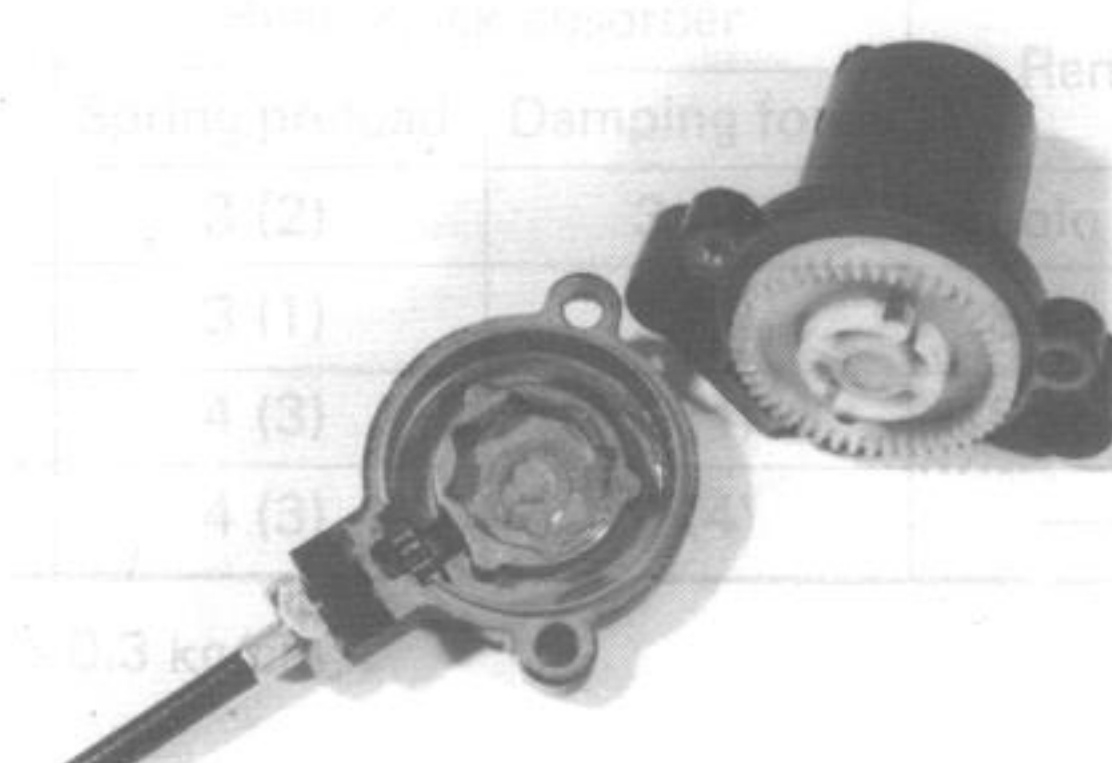

- Mount the rear shock absorber, cushion rod, cushion lever to the swingarm properly.
- Refer to pages 6-49, 6-50, and 6-55, and tighten bolts and nuts to the specifications.



REAR SUSPENSION

The rear suspension spring pre-load is adjustable to compensate for rider, passenger, load, road conditions and motorcycle speed. The adjustment can be performed by changing the hydraulic spring adjuster position. To change the spring pre-load setting, place the motorcycle on the center stand and turn the hydraulic spring adjuster to the desired position. Position "1" provides the softest spring tension and position "5" provides the stiffest spring tension. This motorcycle is delivered from the factory with its adjuster position set on the "3" position ("2" position for Canada).

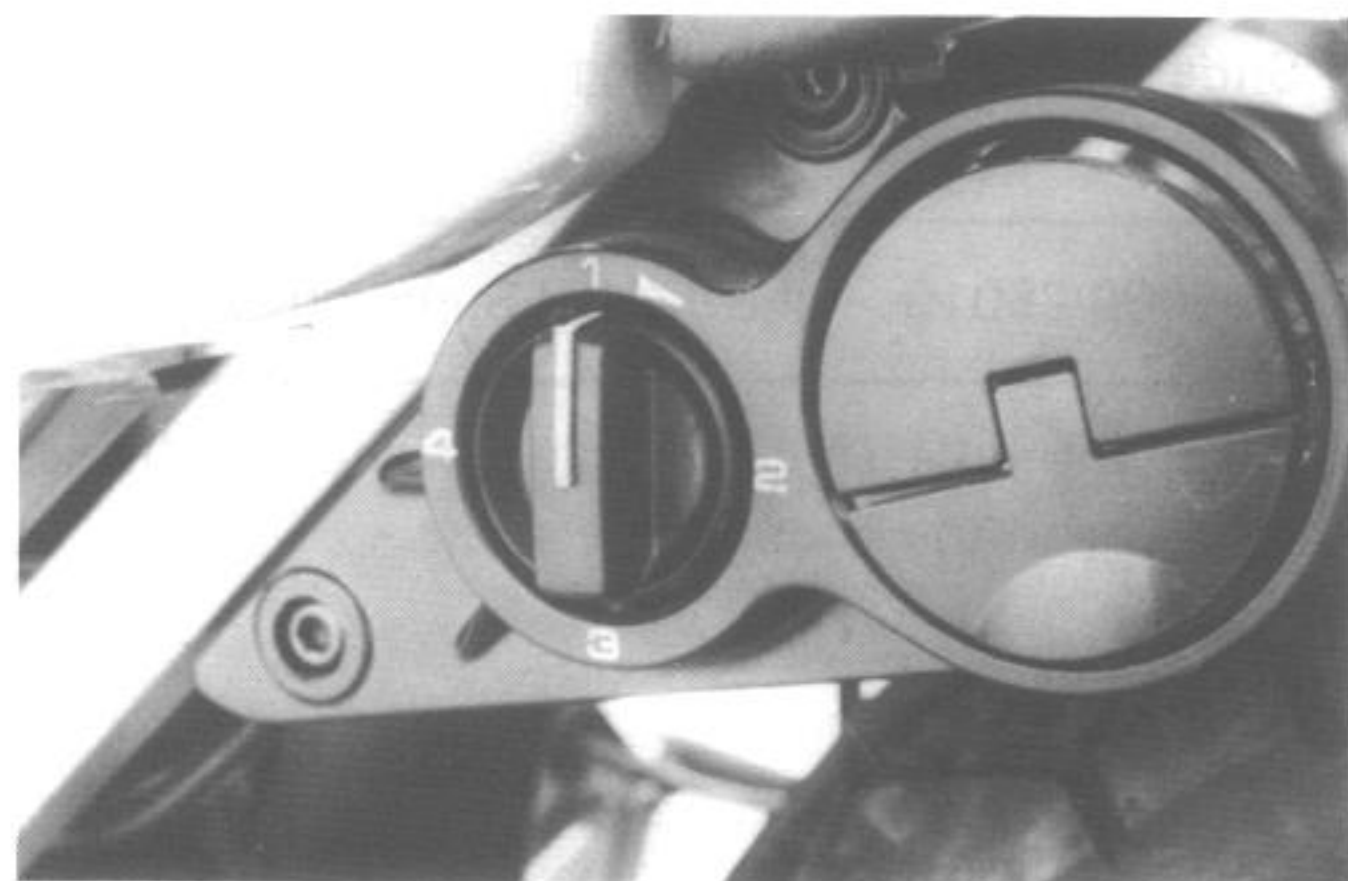

FINAL INSPECTION AND ADJUSTMENT

After installing rear swingarm, shock absorber, brake and rear wheel, following adjustments are required before driving motorcycle.

- * Drive chain 2-17
- * Rear brake 2-18
- * Tire pressure 2-21
- * Chassis bolts and nuts 2-24
- * Shock absorber 6-60

SUSPENSION SETTING

The front suspension of this motorcycle, as indicated in the illustration, can be adjusted to the desired level by turning the adjusters and charging the air (only for Canada).

- ① Front fork spring setting
- ② Damping force setting
- ③ Front fork air pressure (only for Canada)

Standard air pressure	30 kPa (0.3 kg/cm ²)
-----------------------	-------------------------------------

The rear suspension can be adjusted by changing the spring preload and damping force.

- ④ Spring preload setting
- ⑤ Damping force setting

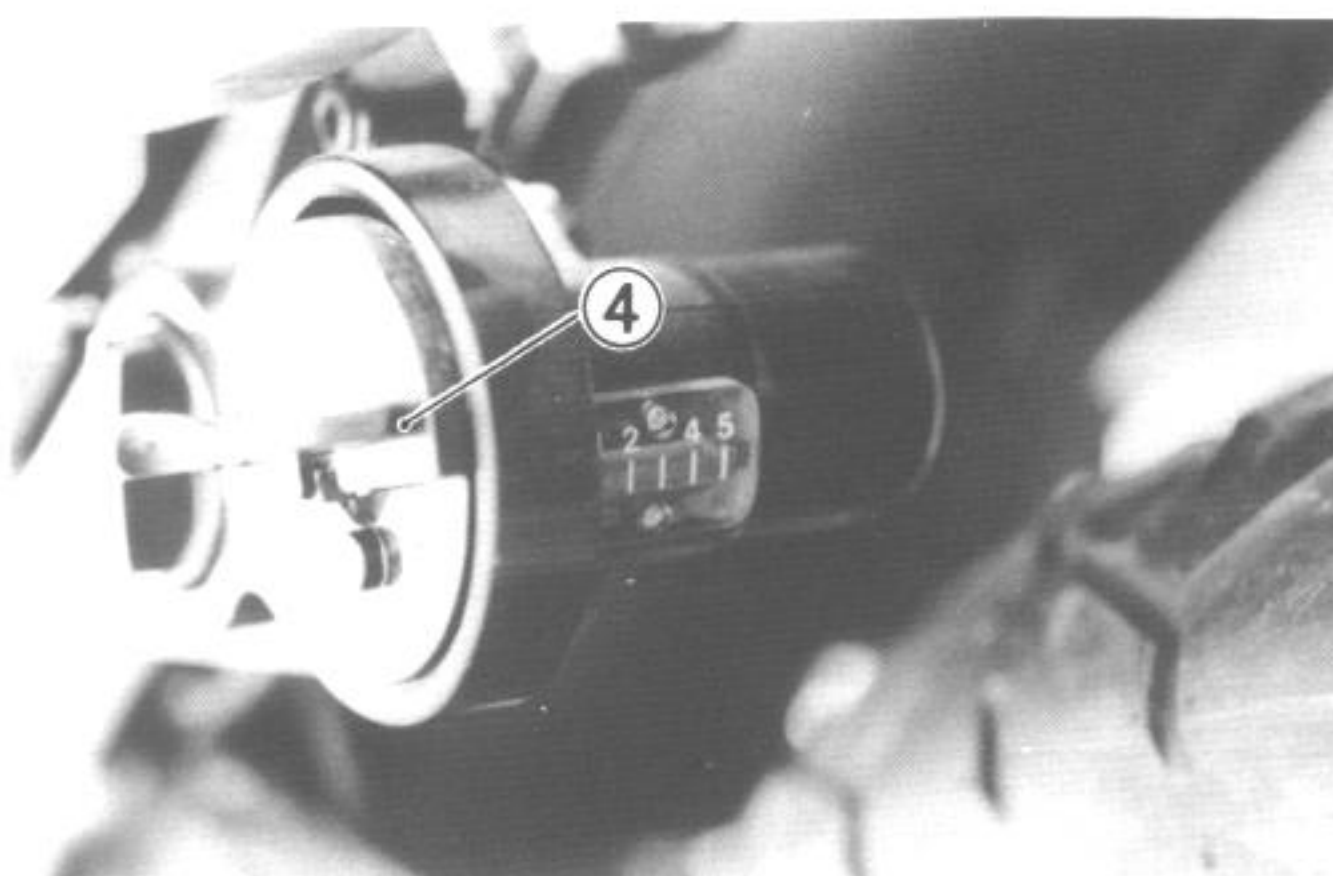

Both front and rear suspensions are adjustable according to the rider's requirements. The high speed capability of this motorcycle make proper suspension setting and balance very important. Use the following table to adjust the front and rear suspensions.

SUSPENSION SETTING TABLE

ITEM	Front fork*		Rear shock absorber		Remarks
	Spring preload	Posi-damp unit setting	Spring preload	Damping force	
Standard	1 (2)	3 (3)	3 (2)	3 (2)	Solo riding
Softer	1 (1)	2 (2)	3 (1)	2 (1)	Solo riding
Stiffer	2 (3)	4 (3)	4 (3)	4 (4)	Solo riding
Dual riding	2 (3)	4 (3)	4 (3)	4 (4)	—

* Standard air pressure of front fork for Canada is 0.3 kg/cm².
() indicates the specifications for Canada.

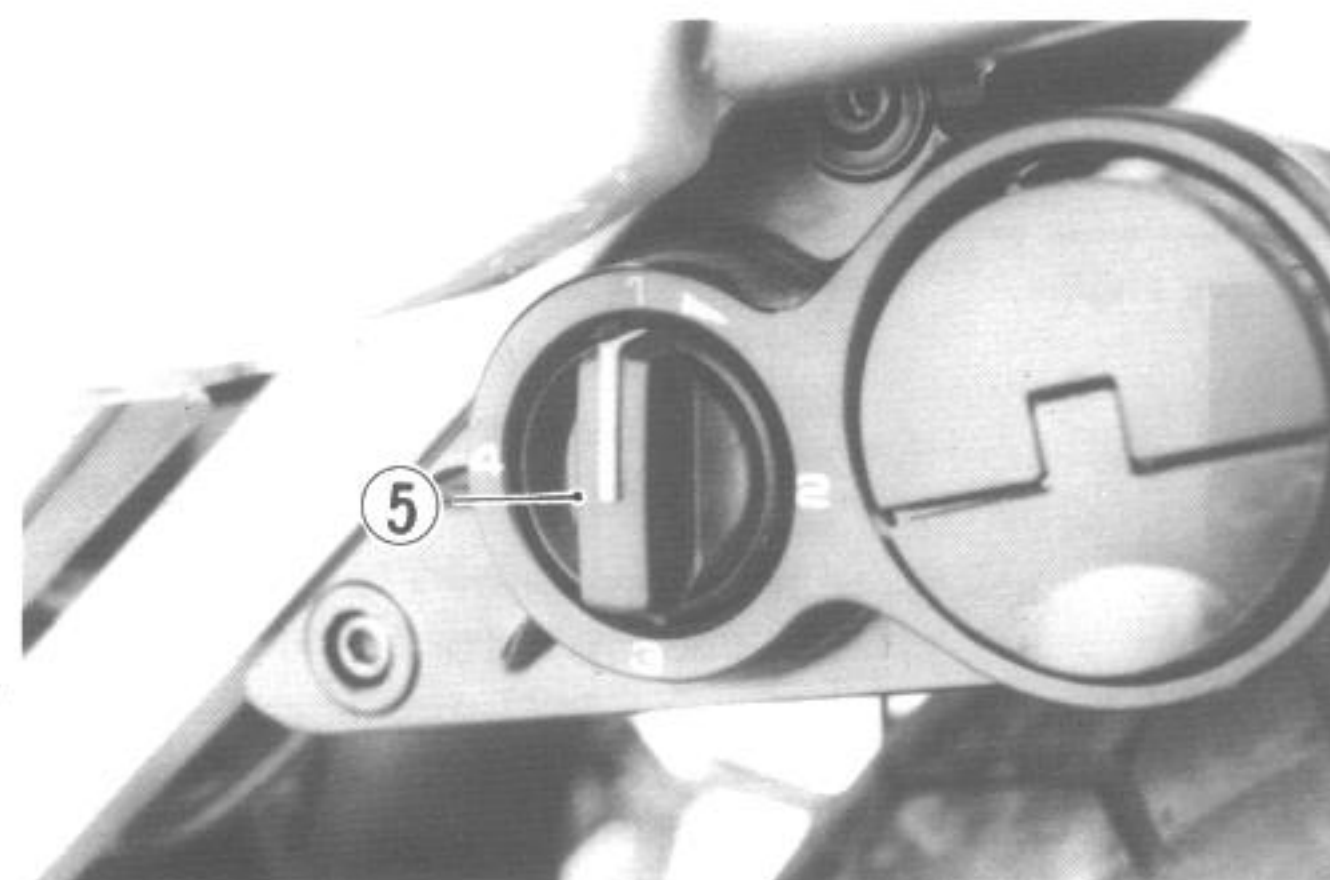
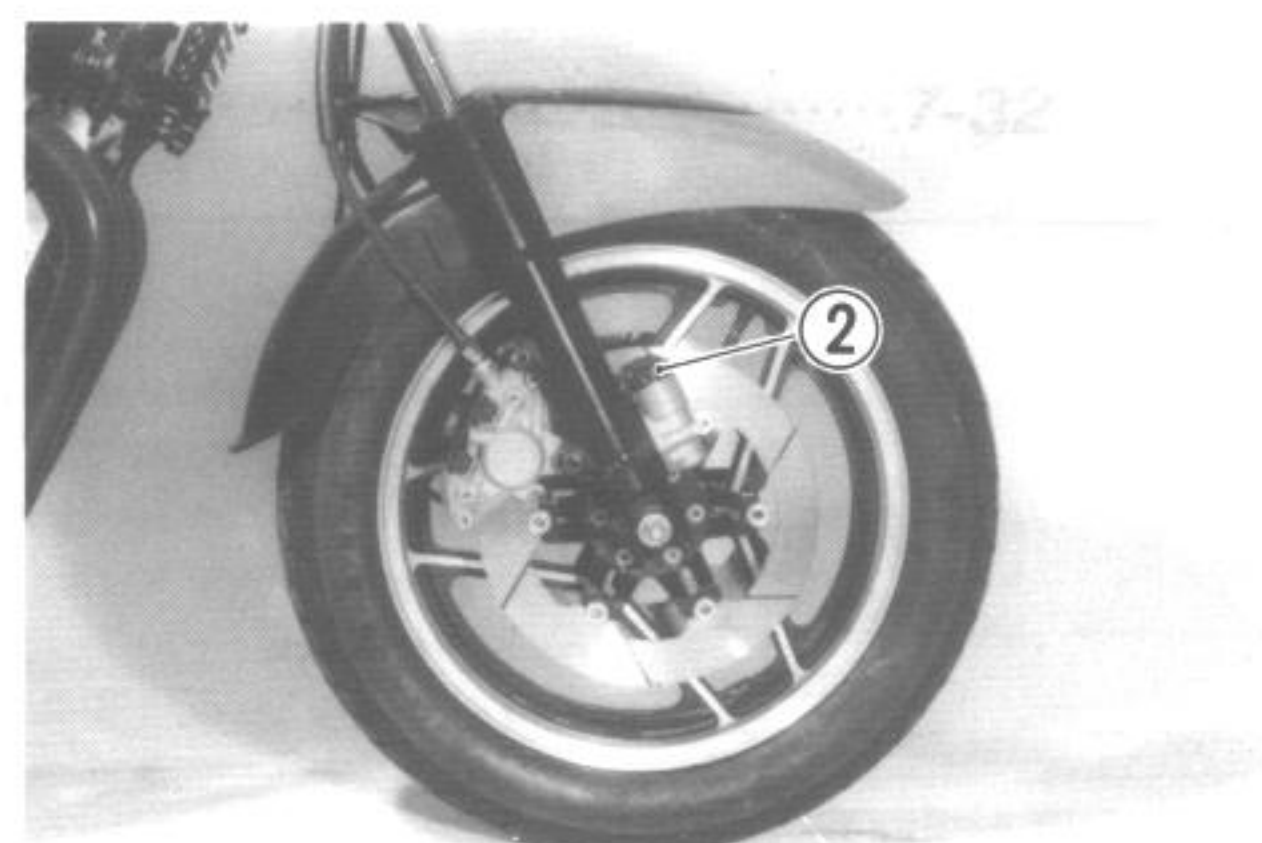
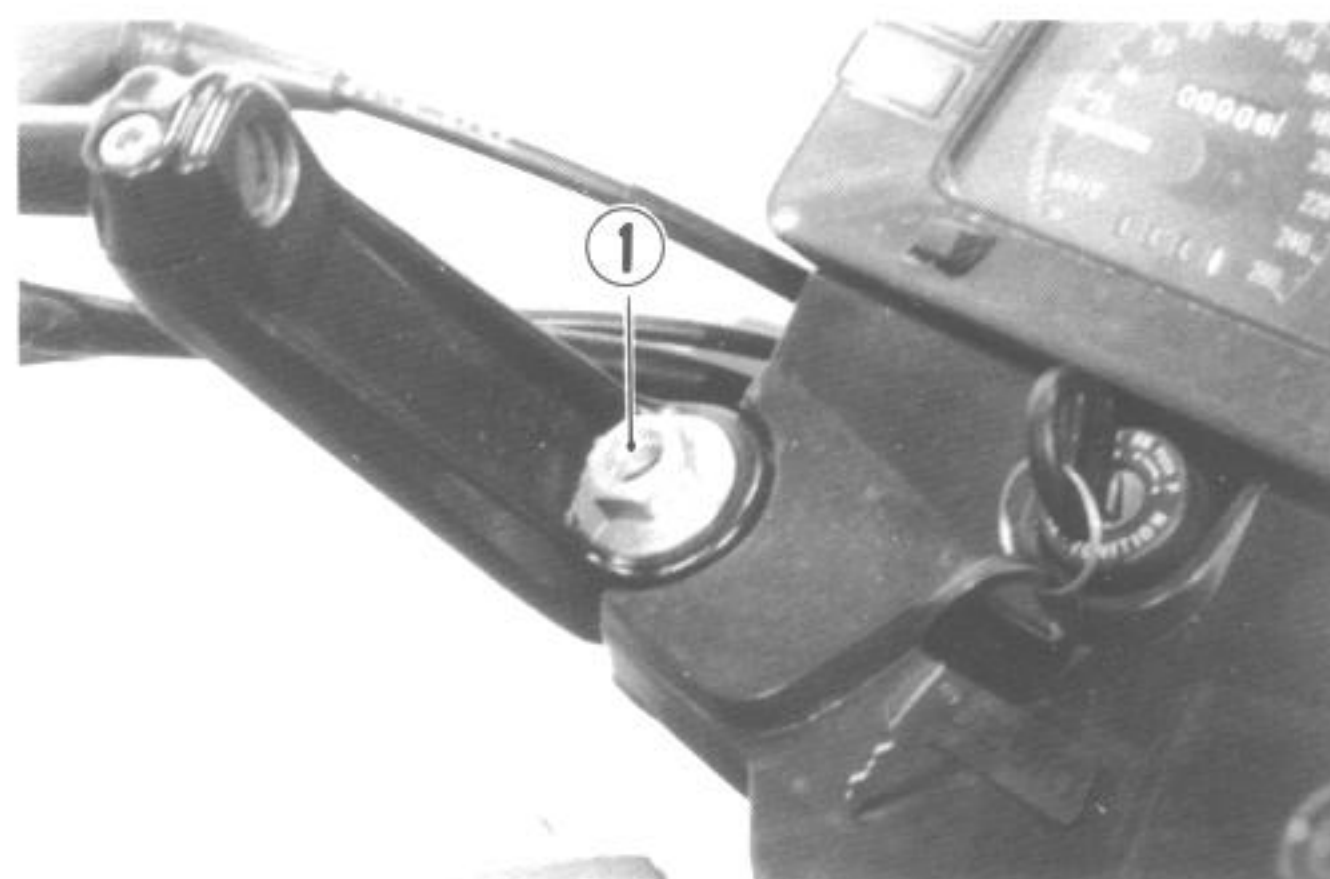

SERVICING INFORMATION

CONTENTS

TROUBLESHOOTING	7- 1
WIRING DIAGRAM	7- 7
WIRE, CABLE AND HOSE ROUTING	7-14
SPECIAL TOOLS	7-24
TIGHTENING TORQUE	7-29
SERVICE DATA	7-32

TROUBLESHOOTING

ENGINE

Complaint	Symptom and possible causes	Remedy
<p>Engine will not start, or is hard to start.</p>	<p>Compression too low</p> <ol style="list-style-type: none"> 1. Valve clearance out of adjustment. 2. Worn valve guides or poor seating of valves. 3. Valves mistiming. 4. Piston rings excessively worn. 5. Worn-down cylinder bores. 6. Starter motor cranks but too slowly. <p>7. Poor seating of spark plug.</p> <p>Plugs not sparking</p> <ol style="list-style-type: none"> 1. Fouled spark plugs. 2. Wet spark plugs. 3. Defective signal generator. 4. Defective transistor unit. 5. Defective ignition coil. 6. Open or short circuit in high-tension cords. <p>No fuel reaching the carburetors</p> <ol style="list-style-type: none"> 1. Clogged hole in the fuel tank cap. 2. Clogged or defective fuel cock. 3. Defective carburetor float valve. 4. Clogged fuel pipe or defective vacuum pipe. 5. Clogged starter jet or starter pipe. 	<p>Adjust. Repair, or replace. Adjust. Replace. Replace, or rebore. Consult "electrical complaints". Retighten.</p> <p>Clean. Clean and dry. Replace. Replace. Replace. Replace.</p> <p>Clean. Clean or replace. Replace. Clean or replace. Clean.</p>
<p>Engine stalls easily.</p>	<ol style="list-style-type: none"> 1. Fouled spark plugs. 2. Defective signal generator. 3. Defective transistor unit. 4. Clogged fuel pipe. 5. Clogged jets in carburetors. 6. Valve clearance out of adjustment. 	<p>Clean. Replace. Replace. Clean. Clean. Adjust.</p>
<p>Noisy engine.</p>	<p>Excessive valve chatter</p> <ol style="list-style-type: none"> 1. Valve clearance too large. 2. Weakened or broken valve springs. 3. Worn down rocker arm or rocker arm shaft. <p>Noise appears to come from pistons</p> <ol style="list-style-type: none"> 1. Pistons or cylinders worn down. 2. Combustion chambers fouled with carbon. 3. Piston pins or piston pin bore worn. 4. Piston rings or ring groove worn. <p>Noise seems to come from timing chain</p> <ol style="list-style-type: none"> 1. Stretched chain. 2. Worn sprockets. 3. Tension adjuster not working. <p>Noise seems to come from clutch</p> <ol style="list-style-type: none"> 1. Worn splines of countershaft or hub. 2. Worn teeth of clutch plates. 3. Distorted clutch plates, driven and drive. 4. Clutch dampers weakened. 5. Excessive primary driven gear axial play. 6. Excessive primary gear back lash. 	<p>Adjust. Replace. Replace.</p> <p>Replace. Clean. Replace. Replace.</p> <p>Replace. Replace. Repair or replace.</p> <p>Replace. Replace. Replace. Replace. Repair or replace. Replace.</p>

Complaint	Symptom and possible causes	Remedy
Noisy engine.	<p>Noise seems to come from crankshaft</p> <ol style="list-style-type: none"> 1. Worn or burnt bearings. 2. Big-end bearings worn and burnt. 3. Thrust clearance too large. <p>Noise seems to come from transmission</p> <ol style="list-style-type: none"> 1. Gears worn or rubbing. 2. Badly worn splines. 3. Primary gears worn or rubbing. 4. Damper spring weakened. 	<p>Replace. Replace. Replace.</p> <p>Replace. Replace. Replace. Replace.</p>
Slipping clutch.	<ol style="list-style-type: none"> 1. Clutch control out of adjustment or loss of play. 2. Weakened clutch springs. 3. Worn or distorted pressure plate. 4. Distorted clutch plates, driven and drive. 	<p>Adjust. Replace. Replace. Replace.</p>
Dragging clutch.	<ol style="list-style-type: none"> 1. Clutch control out of adjustment or too much play. 2. Some clutch springs weakened while others are not. 3. Distorted pressure plate or clutch plates. 4. Wrong viscosity engine oil. 5. Wave washer weaken or broken piano wire. 	<p>Adjust. Replace. Replace. Replace. Replace.</p>
Transmission will not shift.	<ol style="list-style-type: none"> 1. Broken gearshift cam. 2. Distorted gearshift forks. 3. Worn gearshift pawl. 	<p>Replace. Replace. Replace.</p>
Transmission will not shift back.	<ol style="list-style-type: none"> 1. Broken return spring on shift shaft. 2. Shift shaft are rubbing or sticky. 3. Distorted or worn gearshift forks. 	<p>Replace. Repair. Replace.</p>
Transmission jumps out of gear.	<ol style="list-style-type: none"> 1. Worn shifting gears on drive shaft or countershaft. 2. Distorted or worn gearshift forks. 3. Weakened stopper pawl spring on gearshift cam. 4. Worn gearshift pawl. 5. Worn gearshift cam. 	<p>Replace. Replace. Replace. Replace. Replace.</p>
Engine idles poorly.	<ol style="list-style-type: none"> 1. Valve clearance out of adjustment. 2. Poor seating of valves. 3. Defective valve guides. 4. Worn rocker arm or arm shaft. 5. Defective signal generator. 7. Spark plug gaps too wide. 8. Defective ignition coil resulting in weak spark. 9. Float-chamber fuel level out of adjustment in carburetors. 10. Clogged or loosened pilot jet, pilot air jet. 11. Air leaking from carburetors joint, carburetor balancer gauge joint, or starter body. 12. Clogged pilot outlet or bypass. 13. Starter plunger out of adjustment. 	<p>Adjust. Replace. Replace. Replace. Replace. Adjust or replace. Replace. Adjust.</p> <p>Clean or tighten. Tighten or replace.</p> <p>Clean. Adjust.</p>
Engine runs poorly in high-speed range.	<ol style="list-style-type: none"> 1. Valve springs weakened. 2. Valve timing out of adjustment. 3. Worn cams or rocker arms. 4. Spark plug gaps too narrow. 5. Ignition not advanced sufficiently due to poorly working ignitor. 6. Defective ignition coil. 7. Float-chamber fuel level too low. 8. Clogged air cleaner element. 	<p>Replace. Adjust. Replace. Adjust. Replace.</p> <p>Replace. Adjust. Clean.</p>

Complaint	Symptom and possible causes	Remedy
Engine runs poorly in high-speed range.	<ol style="list-style-type: none"> 9. Clogged fuel pipe, resulting in inadequate fuel supply to carburetors. 10. Clogged fuel cock vacuum pipe or pipe sucking air. 11. Clogged main jet or main air jet. 12. Clogged needle jet. 13. Broken O-ring in needle valve. 14. Broken diaphragm of carburetor piston. 15. Clogged needle valve filter. 16. Worn or damaged needle valve. 17. Broken needle valve spring. 	<p>Clean, and prime.</p> <p>Clean or replace. Clean. Clean. Replace. Replace. Clean. Replace. Replace.</p>
Dirty or heavy exhaust smoke.	<ol style="list-style-type: none"> 1. Too much engine oil in the engine. 2. Worn piston rings or cylinders. 3. Worn valve guides. 4. Cylinder walls scored or scuffed. 5. Worn valves stems. 6. Defective stem seal. 7. Worn side rails of oil ring. 	<p>Check with inspection window drain out excess oil.</p> <p>Replace. Replace. Replace. Replace. Replace. Replace.</p>
Engine lacks power.	<ol style="list-style-type: none"> 1. Loss of valve clearance. 2. Weakened valve springs. 3. Valve timing out of adjustment. 4. Worn piston rings or cylinders. 5. Poor seating of valves. 6. Fouled spark plugs. 7. Worn rocker arms or its shafts. 8. Spark plug gaps incorrect. 9. Clogged jets in carburetors. 10. Float-chamber fuel level out of adjustment. 11. Clogged air cleaner element. 12. Carburetor balancing screw loose. 13. Too much engine oil. 	<p>Adjust. Replace. Adjust. Replace. Repair. Clean or replace. Replace. Adjust or replace. Clean. Adjust. Clean. Retighten. Drain out excess oil.</p>
Engine overheats.	<ol style="list-style-type: none"> 1. Heavy carbon deposit on piston crowns. 2. Not enough oil in the engine. 3. Defective oil pump or clogged oil circuit. 4. Fuel level too low in float chambers. 5. Sucking air from intake pipes. 6. Use of incorrect engine oil. 	<p>Clean. Add oil. Repair or clean. Adjust. Retighten or replace. Change.</p>

ELECTRICAL

Complaint	Symptom and possible causes	Remedy
No sparking or poor sparking.	<ol style="list-style-type: none"> 1. Defective ignition coil. 2. Defective spark plugs. 3. Defective signal generator. 4. Defective transistor unit. 5. Low battery charge. 	<p>Replace. Replace. Replace. Replace. Recharge.</p>
Spark plugs soon become fouled with carbon.	<ol style="list-style-type: none"> 1. Idling speed set too high. 2. Incorrect gasoline. 3. Dirty element in air cleaner. 4. Spark plugs too cold. 	<p>Adjust carburetors. Change. Clean. Replace by hot type plugs.</p>

Complaint	Symptom and possible causes	Remedy
Spark plugs become fouled too soon.	<ol style="list-style-type: none"> 1. Worn piston rings. 2. Pistons or cylinders worn. 3. Excessive clearance of valve stems in valve guides. 4. Worn stem oil seal. 	Replace. Replace. Replace. Replace.
Spark plug electrodes overheat or burn.	<ol style="list-style-type: none"> 1. Spark plugs too hot. 2. The engine overheats. 3. Spark plugs loosen. 	Replace by cold type plugs. Tune up. Retighten.
Generator does not charge.	<ol style="list-style-type: none"> 1. Open or short in lead wires, or loose lead connections. 2. Shorted, grounded or open generator coils. 3. Shorted or open regulator/rectifier. 	Repair, replace or retighten. Replace. Replace.
Generator does charge, but charging rate is below the specification.	<ol style="list-style-type: none"> 1. Lead wires tend to get shorted or open-circuited or loosely connected at terminals. 2. Grounded or open-circuited stator coils of generator. 3. Defective regulator/rectifier. 4. Not enough electrolyte in the battery. 5. Defective cell plates in the battery. 	Repair or retighten. Replace. Replace. Add distilled water to the upper level. Replace the battery.
Generator overcharges.	<ol style="list-style-type: none"> 1. Internal short-circuit in the battery. 2. Resistor element in the regulator/rectifier damaged or defective. 3. Regulator/rectifier poorly grounded. 	Replace the battery. Replace. Clean and tighten ground connection.
Unstable charging.	<ol style="list-style-type: none"> 1. Lead wire insulation frayed due to vibration, resulting in intermittent shorting. 2. Generator internally shorted. 3. Defective regulator/rectifier. 	Repair or replace. Replace. Replace.
Starter button is not effective.	<ol style="list-style-type: none"> 1. Battery run down. 2. Defective switch contacts. 3. Brushes not seating properly on commutator in starter motor. 4. Defective starter relay. 5. Wiring connections loose or disconnected. 	Recharge or replace. Replace. Repair or replace. Replace. Connect, tighten or repair.
Battery "sulfation" ("Sulfation"; acidic white powdery substance or spots on surfaces of cell plates.)	<ol style="list-style-type: none"> 1. Charging rate too low or too high. (When not in use batteries should be recharged at least once a month to avoid sulfation.) 2. Battery electrolyte excessive or insufficient, or its specific gravity too high or too low. 3. The battery left unused in a run-down condition for too long in cold climate. 4. Contaminated electrolyte. (Foreign matter has entered, mixed with the electrolyte, and contaminated it.) 	Replace the battery. Keep the electrolyte up to the prescribed level, or adjust the S.G. by consulting the battery maker's directions. Replace the battery, if badly sulfated. If "sulfation" has not advanced too far, try to restore the battery by replacing the electrolyte, recharging it fully with the battery detached from the motorcycle and then adjusting electrolyte's S.G.

Complaint	Symptom and possible causes	Remedy
Battery discharges too rapidly.	<ol style="list-style-type: none"> 1. Dirty container. 2. Impurities in the electrolyte or electrolyte S.G. is too high. 3. The charging system is not set for proper charging operation. 4. Cell plates have lost much of their active material as a result of overcharging. 5. A short-circuit condition exists within the battery due to an excessive accumulation of sediments caused by the electrolyte's high S.G. 6. Electrolyte's S.G. is too low. 7. Contaminated electrolyte. 	<p>Clean. Change the electrolyte by consulting the battery maker's directions. Check the generator, regulator/rectifier and circuit connections, and make necessary adjustments for specified charging operation. Replace the battery, and correct the charging system. Replace the battery.</p> <p>Recharge the battery fully and adjust electrolyte's S.G. Replace the electrolyte, recharge the battery and then adjust S.G. Replace the battery.</p>
Reversed battery polarity.	The battery has been connected the other way around in the system, so that it is being charged in the reverse direction.	Replace the battery and be sure to connect the battery properly.

CHASSIS

Complaint	Symptom and possible causes	Remedy
Handling feels too heavy.	<ol style="list-style-type: none"> 1. Steering stem nut overtightened. 2. Worn roller bearing or race in steering stem. 3. Distorted steering stem. 4. Not enough pressure in tires. 5. Overtightened steering races. 	<p>Adjust. Replace. Replace. Adjust. Adjust.</p>
Steering oscillation.	<ol style="list-style-type: none"> 1. Loss of balance between right and left suspensions. 2. Bent front fork. 3. Bent front axle or crooked tire. 4. Loose steering stem bearings. 5. Worn or incorrect tires or wrong tire pressure. 	<p>Adjust. Repair or replace. Replace. Adjust. Adjust, or replace.</p>
Wobbly front wheel.	<ol style="list-style-type: none"> 1. Distorted wheel. 2. Worn front wheel bearings. 3. Defective or incorrect tire. 4. Loose nut on axle. 5. Loose nuts on rear shock. 6. Worn swingarm related bearings. 	<p>Replace. Replace. Replace. Retighten. Retighten. Replace.</p>
Front suspension too soft.	<ol style="list-style-type: none"> 1. Weakened springs. 2. Not enough fork oil. 3. Not enough fork air. (only for Canada) 4. Wrong weight fork oil. 	<p>Replace. Refill. Adjust to specification. Replace.</p>

Complaint	Symptom and possible causes	Remedy
Front suspension too stiff.	<ol style="list-style-type: none"> 1. Fork oil too viscous. 2. Too much fork oil. 3. Fork air too high. (only for Canada) 4. Front axle bent. 5. Fork tubes not adjusted evenly in fork stem and steering stem head. 	Replace. Remove excess oil. Adjust to specification. Replace. Adjust.
Noisy front suspension.	<ol style="list-style-type: none"> 1. Not enough fork oil. 2. Loose nuts on suspension. 	Refill. Retighten.
Wobbly rear wheel.	<ol style="list-style-type: none"> 1. Distorted wheel rim. 2. Worn-down rear wheel bearings or swingarm bearings. 3. Defective or incorrect tire. 4. Worn swingarm related bearings. 5. Loose nuts on rear suspensions. 	Replace. Replace. Replace. Replace. Retighten.
Rear suspension too soft.	<ol style="list-style-type: none"> 1. Weakened springs. 2. Rear suspension adjusters improperly set. 3. Oil leakage of rear shock absorber. 	Replace. Reset. Replace.
Rear suspension too stiff.	<ol style="list-style-type: none"> 1. Rear suspension adjusters improperly set. 2. Shock absorber shaft(s) bent. 3. Swing arm bent. 4. Worn swingarm related bearing. 	Adjust. Replace. Replace. Replace.
Noisy rear suspension.	<ol style="list-style-type: none"> 1. Loose nut on rear suspension. 2. Worn swingarm related bearings. 	Retighten. Replace.
Insufficient brake power.	<ol style="list-style-type: none"> 1. Leakage of brake fluid from hydraulic system. 2. Worn pads. 3. Oil adhesion on engaging surface of pads. 4. Worn disc. 5. Air entered into hydraulic system. 	Repair or replace. Replace. Clean disc and pads. Replace. Bleed air.
Brake squeaking.	<ol style="list-style-type: none"> 1. Carbon adhesion on pad surface. 2. Tilted pad. 3. Damaged wheel bearing. 4. Loosened front-wheel axle or rear-wheel axle. 5. Worn pads. 6. Foreign substance entered into brake fluid. 7. Clogged return port of master cylinder. 8. Wrongly fixed pad shims. 9. Calipers binding on caliper axles. 	Repair surface with sandpaper. Modify and fitting. Replace. Tighten to regular torque. Replace. Replace brake fluid. Disassemble and clean master cylinder. Set correctly. Clean and lubricate.
Excessive brake lever stroke.	<ol style="list-style-type: none"> 1. Air entered into hydraulic system. 2. Insufficient brake fluid. 3. Improper quality of brake fluid. 	Bleed air. Replenish fluid to normal level; bleed air. Replace with correct fluid.
Leakage of brake fluid.	<ol style="list-style-type: none"> 1. Insufficient tightening of connection joints. 2. Cracked hose. 3. Worn piston seal. 	Tighten to specified torque. Replace. Replace.

WIRING DIAGRAM (For E01 and E24)

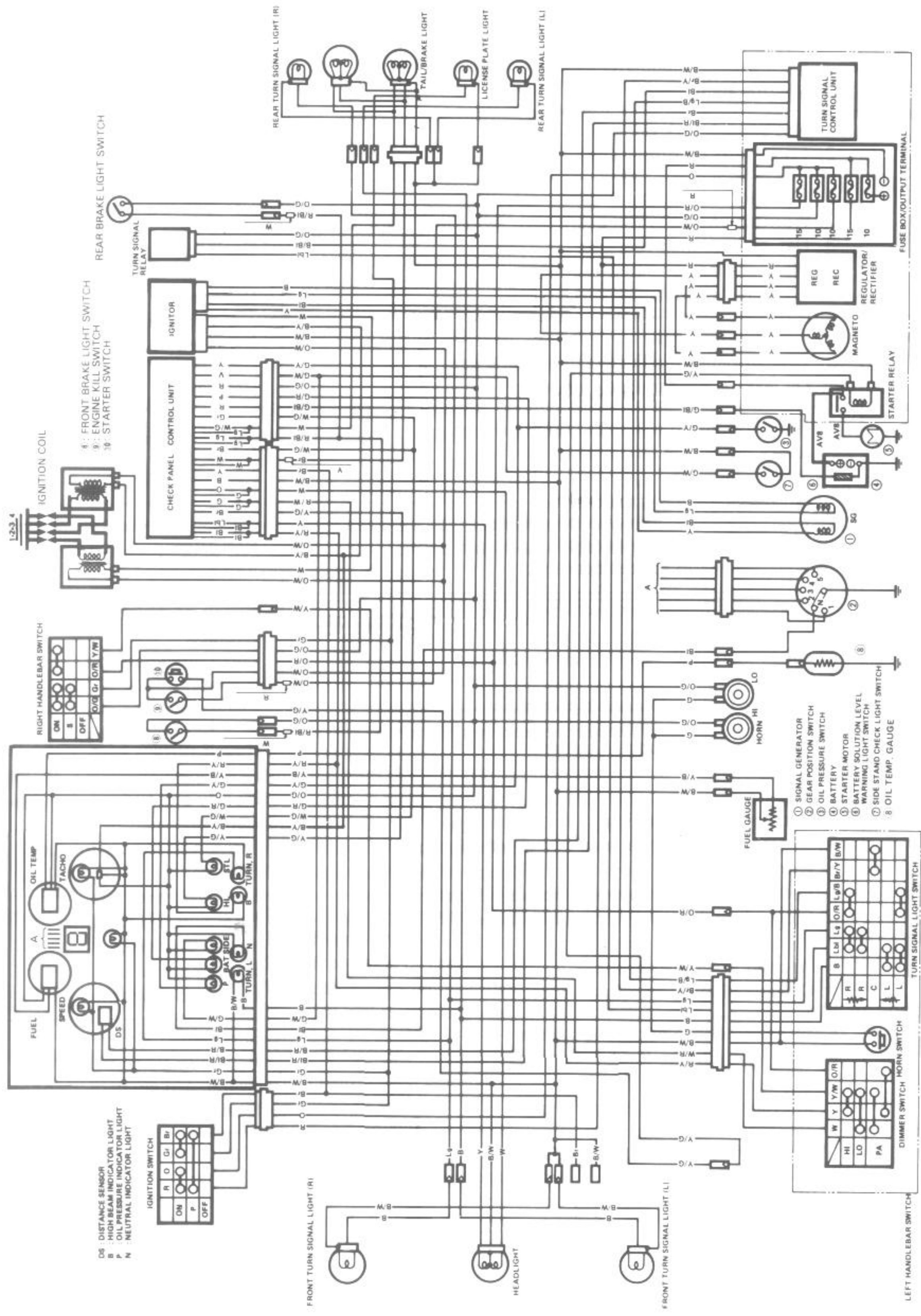

D6 : DISTANCE SENSOR
 B : HIGH BEAM INDICATOR LIGHT
 P : OIL PRESSURE INDICATOR LIGHT
 N : NEUTRAL INDICATOR LIGHT

WIRE COLOR
 BBlack
 BlBlue
 BrBrown
 GGreen
 GrGray
 LblLight blue
 LgLight green

OOrange
 PPink
 RRed
 VViolet
 WWhite
 YYellow
 B/BlBlack with Blue tracer

B/RBlack with Red tracer
 B/WBlack with White tracer
 B/YBlack with Yellow tracer
 Bl/RBlue with Red tracer
 Br/YBrown with Yellow tracer
 G/BlGreen with Blue tracer
 G/RGreen with Red tracer

G/WGreen with White tracer
 G/YGreen with Yellow tracer
 Lg/BLight green with Black tracer
 O/GOrange with Green tracer
 O/ROrange with Red tracer
 O/WOrange with White tracer
 R/BlRed with Blue tracer

R/WRed with White tracer
 R/YRed with Yellow tracer
 W/GWhite with Green tracer
 W/RWhite with Red tracer
 Y/BYellow with Black tracer
 Y/GYellow with Green tracer
 Y/WYellow with White tracer

(For E02, 04, 16, 17, 18, 21, 25 and 39)

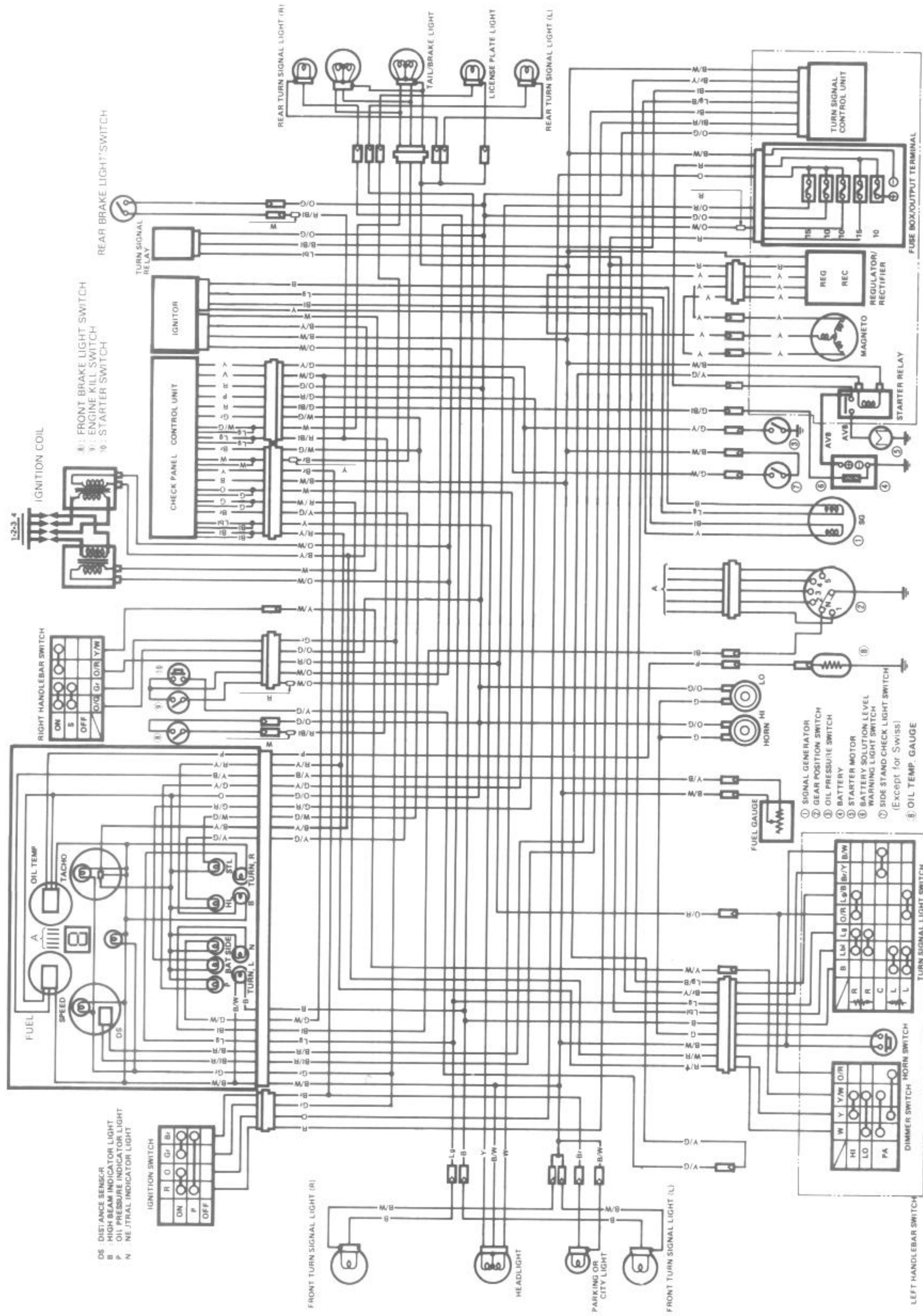

- WIRE COLOR**
- BBlack
 - BlBlue
 - BrBrown
 - GGreen
 - GrGray
 - LblLight blue
 - LgLight green
 - OOrange
 - PPink
 - RRed
 - VViolet
 - WWhite
 - YYellow
 - B/BlBlack with Blue tracer
 - B/RBlack with Red tracer
 - B/WBlack with White tracer
 - Bl/YBlack with Yellow tracer
 - Bl/RBlack with Red tracer
 - Br/YBrown with Yellow tracer
 - G/BlGreen with Blue tracer
 - G/RGreen with Red tracer
 - G/WGreen with White tracer
 - G/YGreen with Yellow tracer
 - Lg/BLight green with Black tracer
 - O/GOrange with Green tracer
 - O/ROrange with Red tracer
 - O/WOrange with White tracer
 - R/BlRed with Blue tracer
 - R/WRed with White tracer
 - R/YRed with Yellow tracer
 - W/GWhite with Green tracer
 - W/RWhite with Red tracer
 - Y/BYellow with Black tracer
 - Y/GYellow with Green tracer
 - Y/WYellow with White tracer

(For E06)

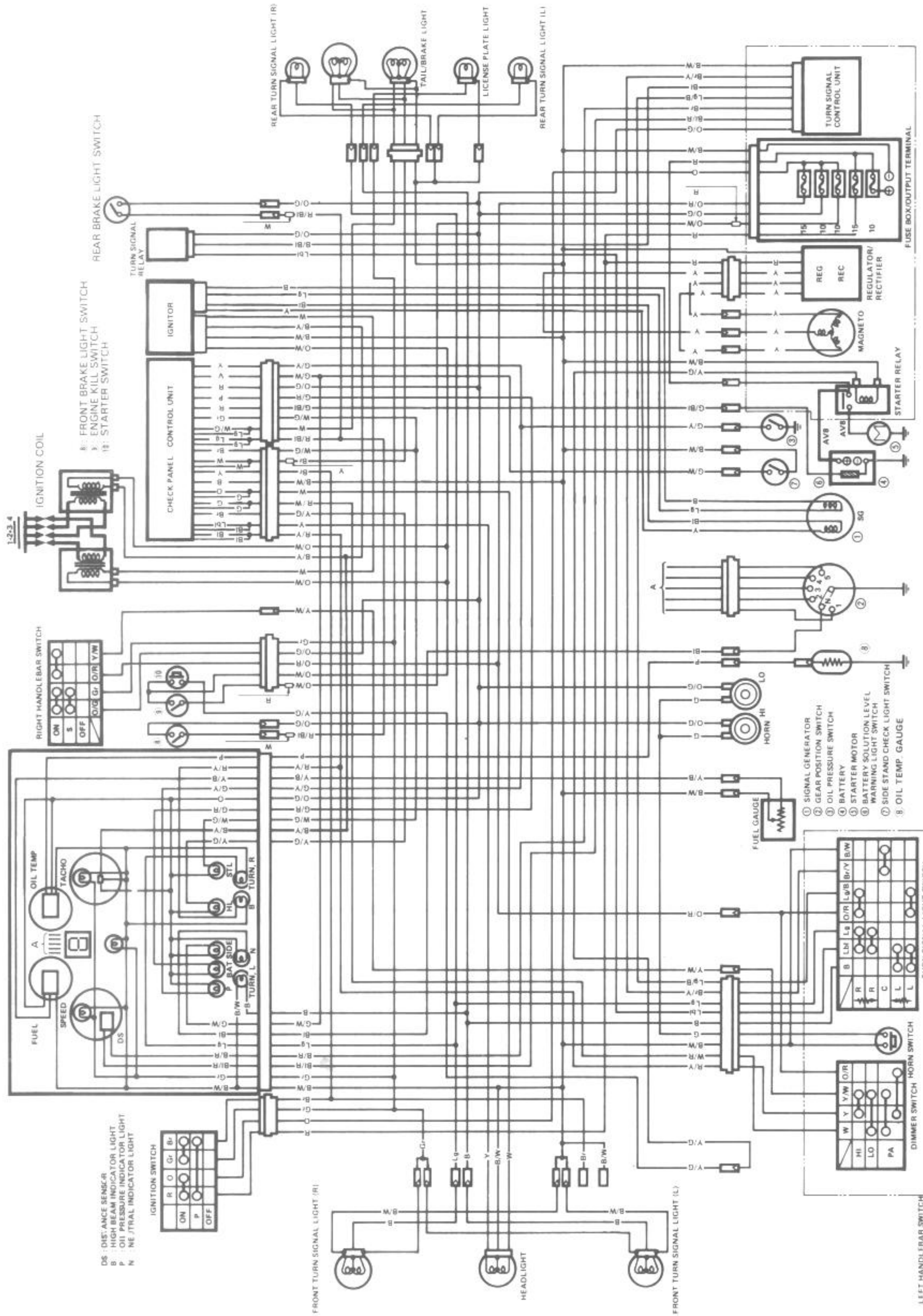

- WIRE COLOR**
- B Black
 - Bl Blue
 - Br Brown
 - G Green
 - Gr Gray
 - Lbl Light blue
 - Lg Light green
 - O Orange
 - P Pink
 - R Red
 - V Violet
 - W White
 - Y Yellow
 - B/Bl Black with Blue tracer
 - B/R Black with Red tracer
 - B/W Black with White tracer
 - B/Y Black with Yellow tracer
 - Bl/R Blue with Red tracer
 - Br/R Brown with Yellow tracer
 - G/Bl Green with Blue tracer
 - G/R Green with Red tracer
 - G/W Green with White tracer
 - G/Y Green with Yellow tracer
 - Lg/B Light green with Black tracer
 - O/G Orange with Green tracer
 - O/R Orange with Red tracer
 - O/W Orange with White tracer
 - R/Bl Red with Blue tracer
 - R/W Red with White tracer
 - R/Y Red with Yellow tracer
 - W/G White with Green tracer
 - W/R White with Red tracer
 - Y/B Yellow with Black tracer
 - Y/G Yellow with Green tracer
 - Y/W Yellow with White tracer

(For E22)

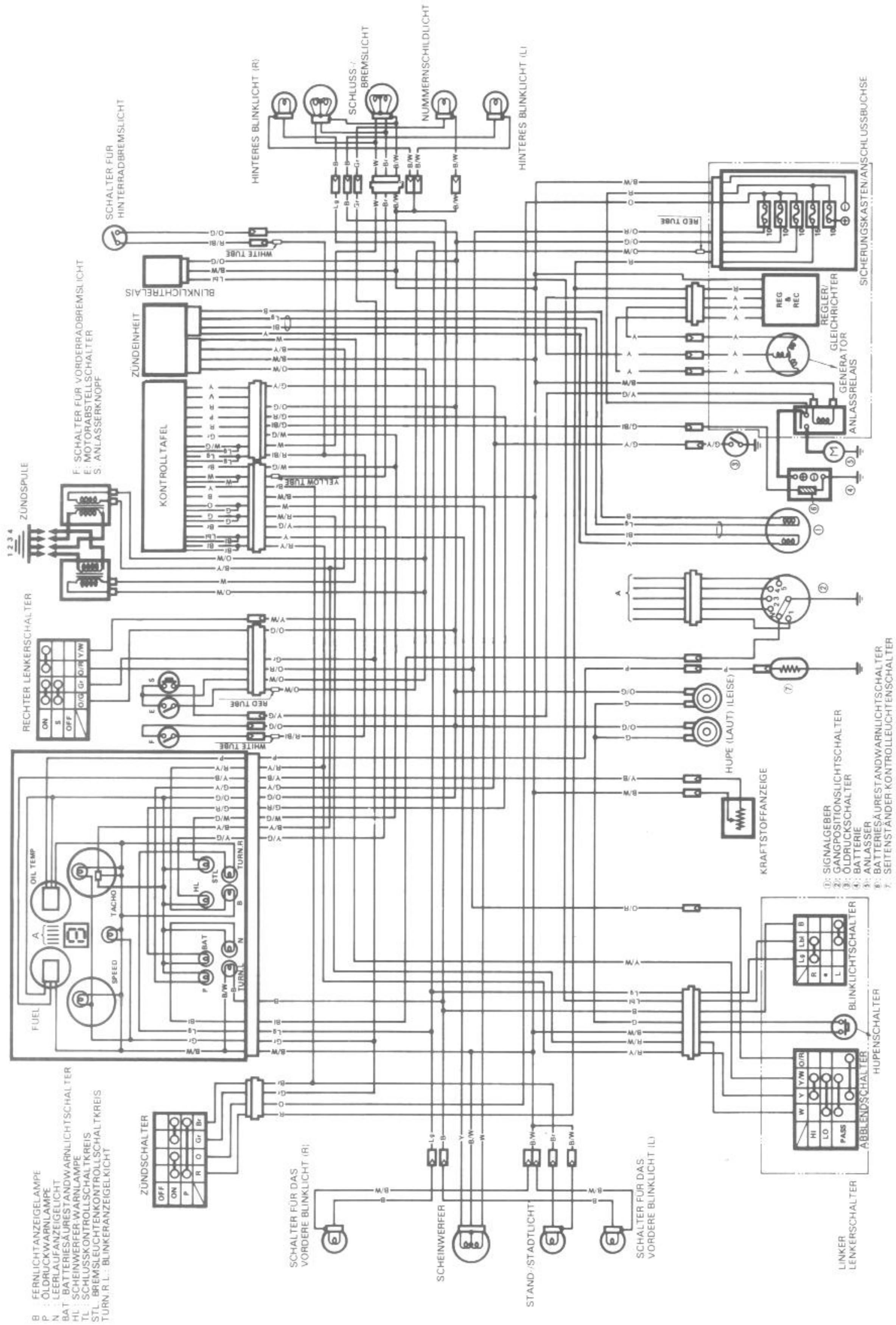

B : FERNLICHTANZEIGELAMPE
 P : ÖLDRUCKWARNLAMPE
 N : LEERLAUFANZEIGELICHT
 BAT : BATTERIESÄURESTANDWARNLICHTSCHALTER
 HL : SCHEINWERFERWARNLAMPE
 TL : SCHLUSSKONTROLLSCHALTSTREIFEN
 STL : BREMSLEUCHTENKONTROLLSCHALTSTREIFEN
 TURN R, L : BLINKERANZEIGELICHT

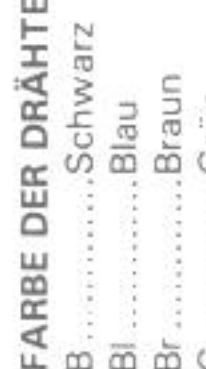
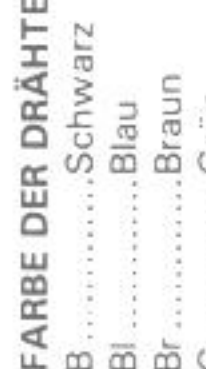
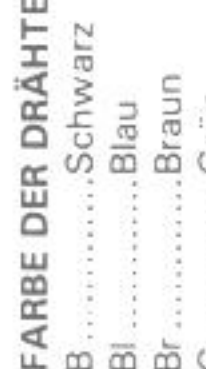
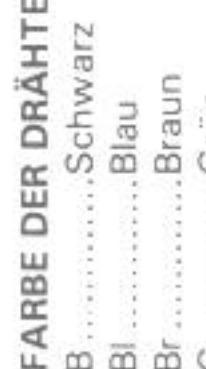
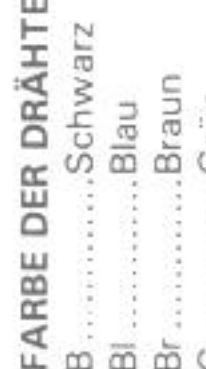
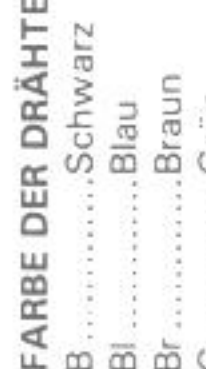
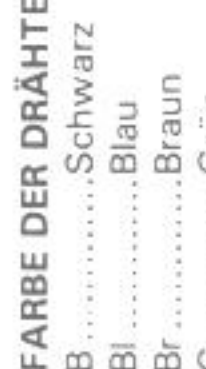
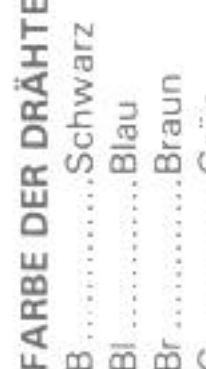
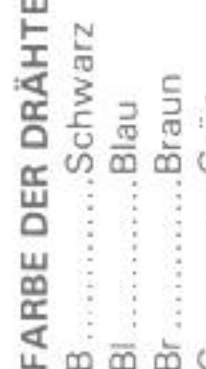
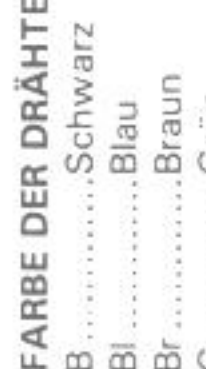
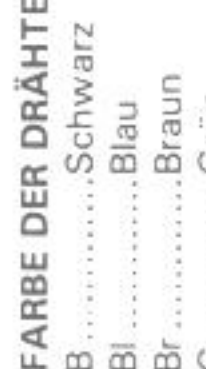
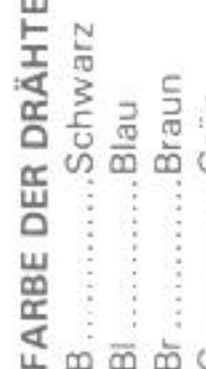
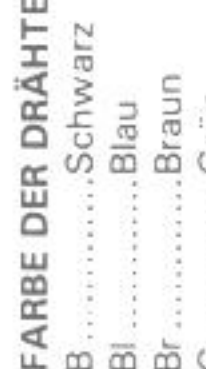
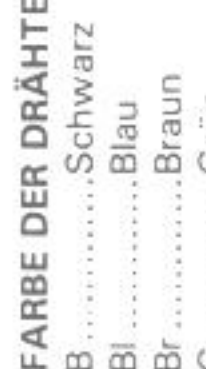
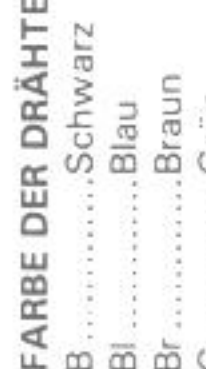
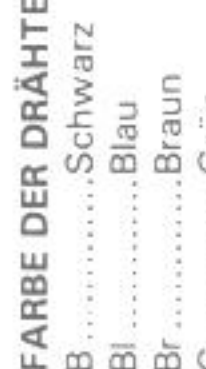
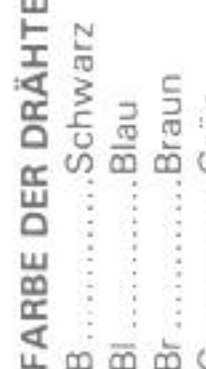
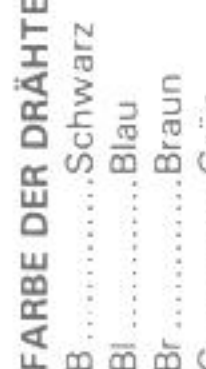
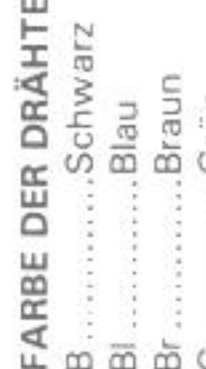
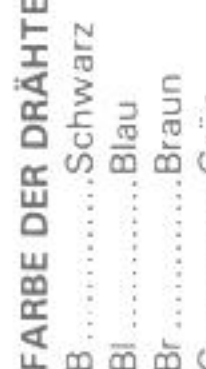
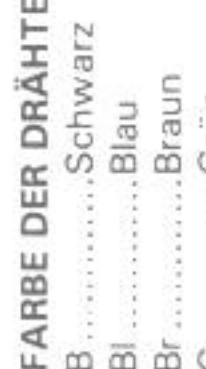
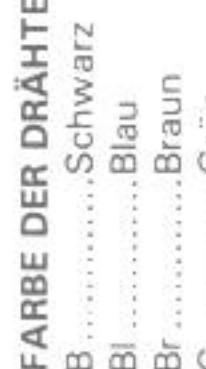
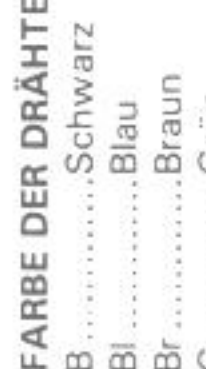
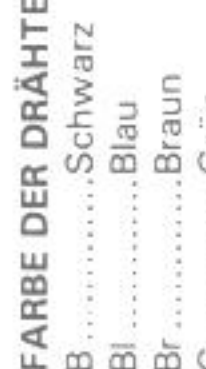
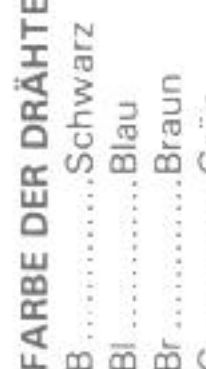
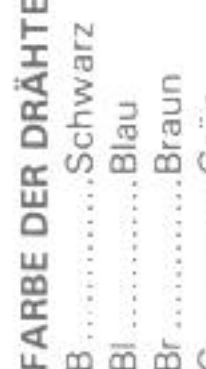
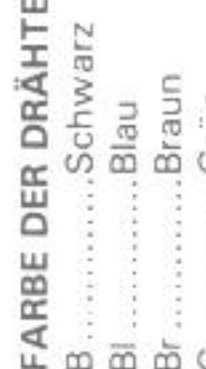
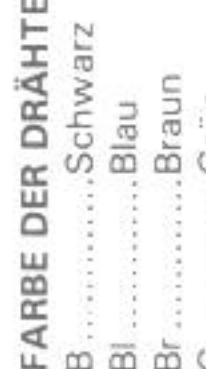
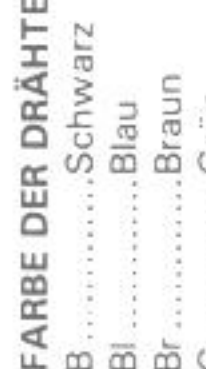
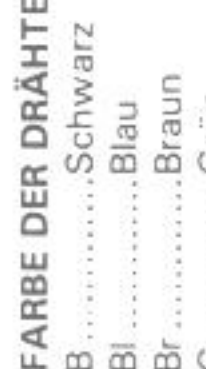
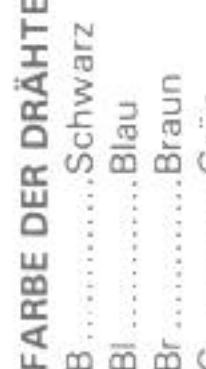
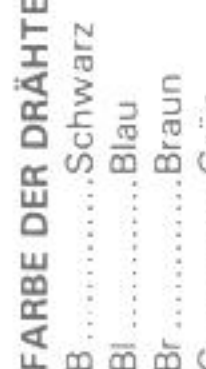
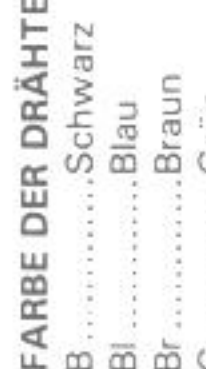
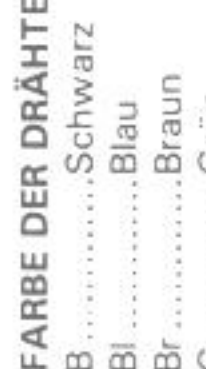
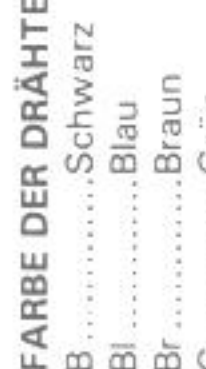
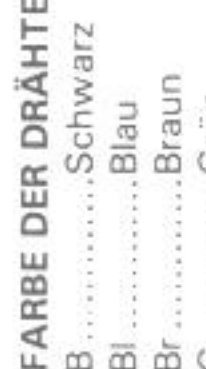
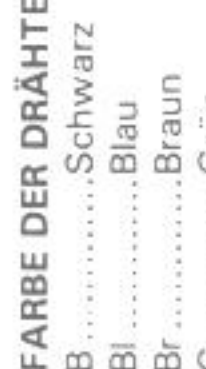
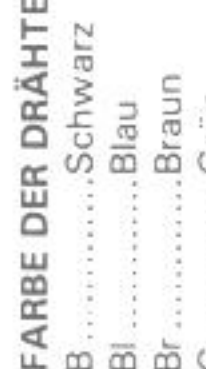
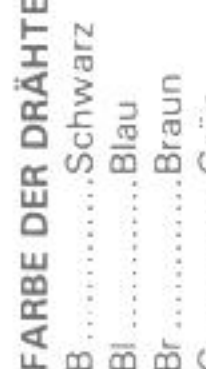
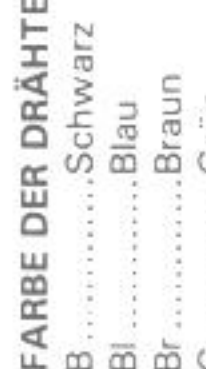
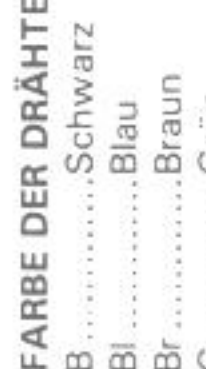
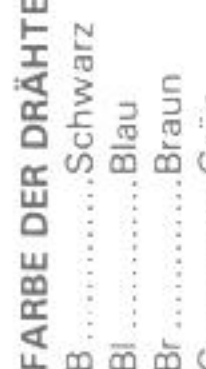
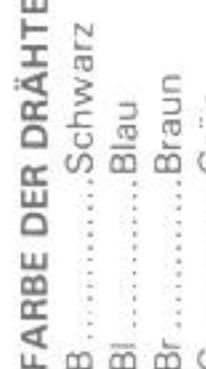
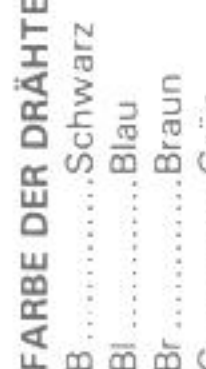
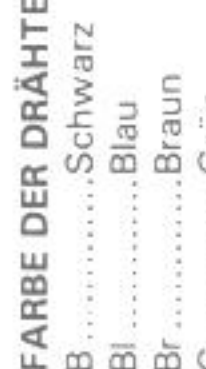
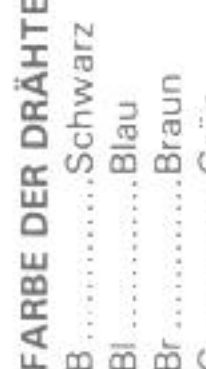
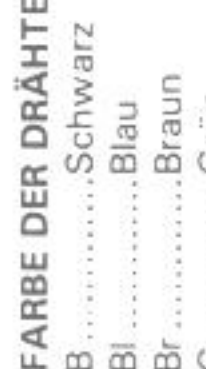
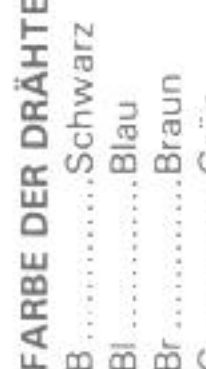
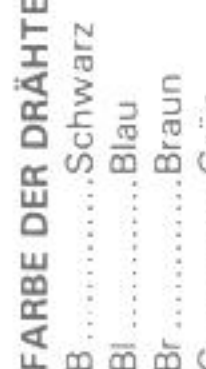
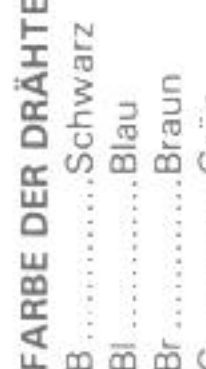
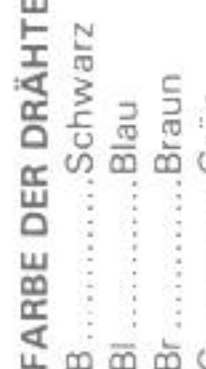
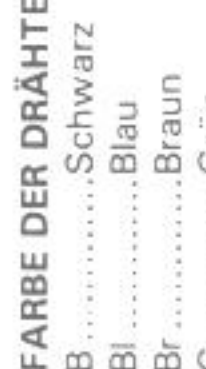
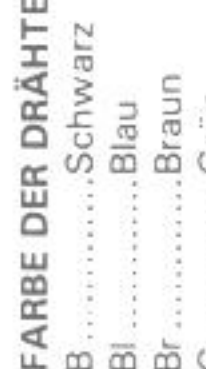
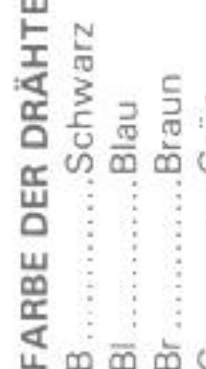
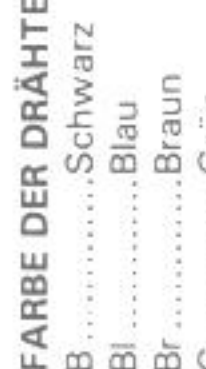
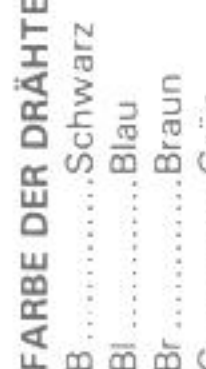
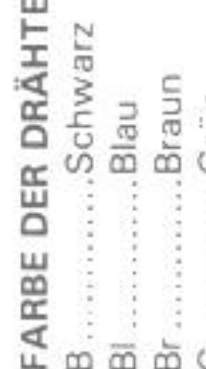
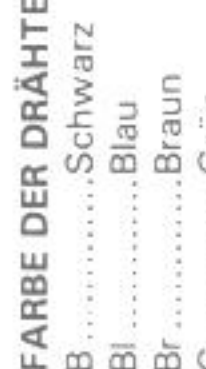
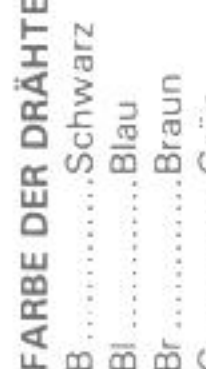
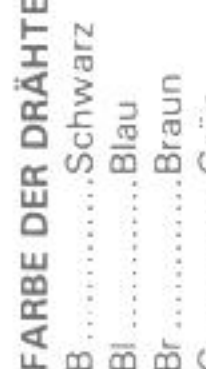
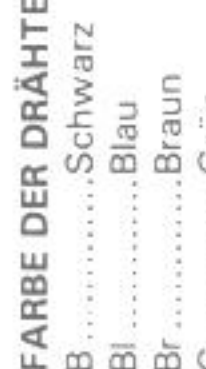
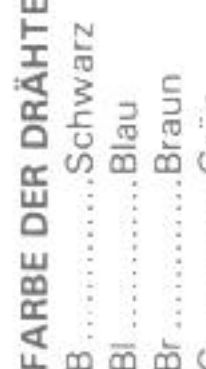
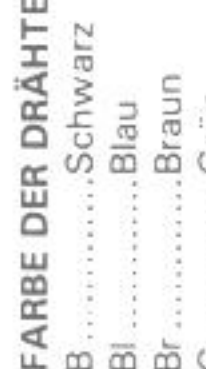
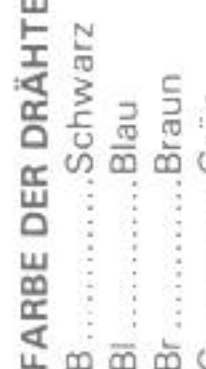
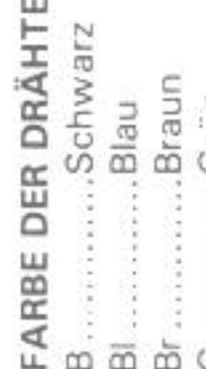
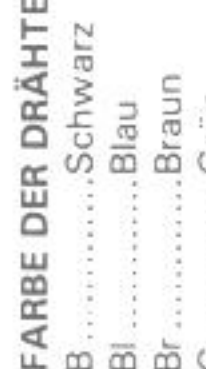
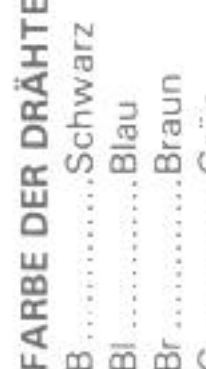
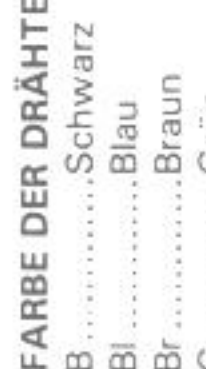
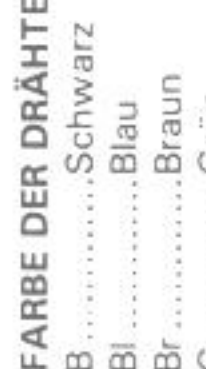
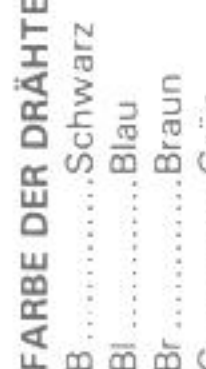
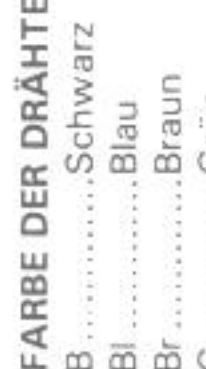
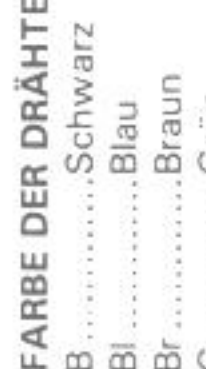
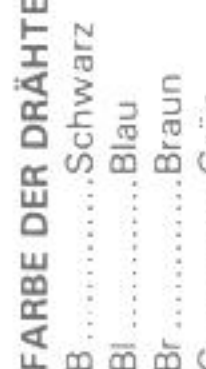
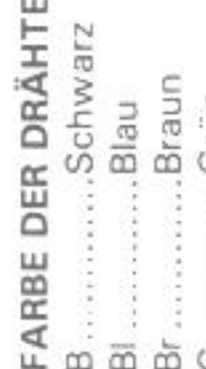
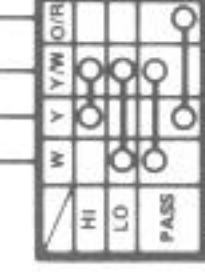
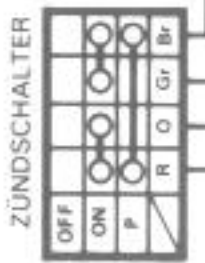

(For E28)

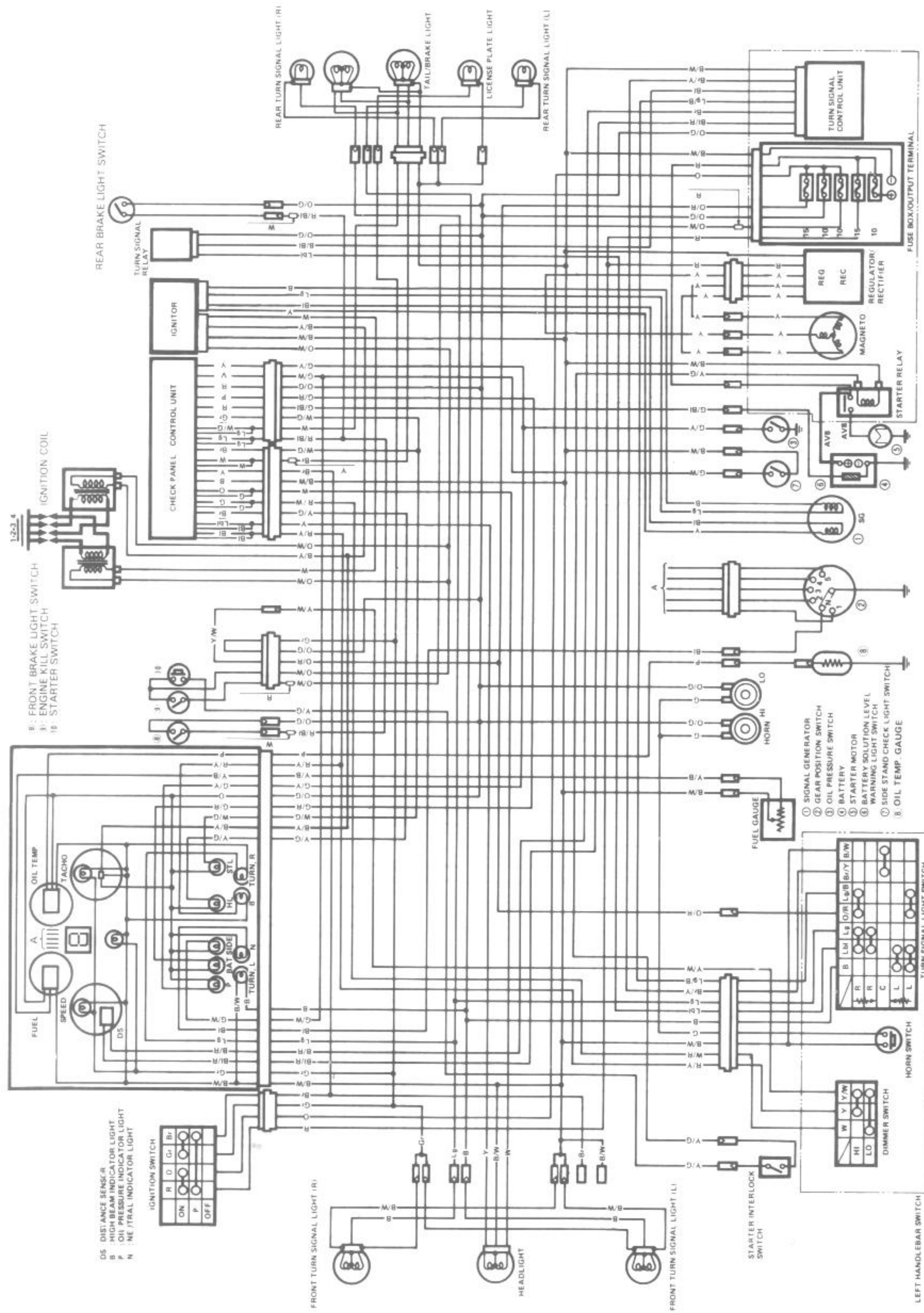

- WIRE COLOR**
- B Black
 - Bl Blue
 - Br Brown
 - G Green
 - Gr Gray
 - Lbl Light blue
 - Lg Light green
 - O Orange
 - P Pink
 - R Red
 - V Violet
 - W White
 - Y Yellow
 - B/Bl Black with Blue tracer
 - B/R Black with Red tracer
 - B/W Black with White tracer
 - B/Y Black with Yellow tracer
 - Bl/R Blue with Red tracer
 - Br/Y Brown with Yellow tracer
 - G/Bl Green with Blue tracer
 - G/R Green with Red tracer
 - G/W Green with White tracer
 - G/Y Green with Yellow tracer
 - Lg/B Light green with Black tracer
 - O/G Orange with Green tracer
 - O/R Orange with Red tracer
 - O/W Orange with White tracer
 - R/Bl Red with Blue tracer
 - R/W Red with White tracer
 - R/Y Red with Yellow tracer
 - W/G White with Green tracer
 - W/R White with Red tracer
 - Y/B Yellow with Black tracer
 - Y/G Yellow with Green tracer
 - Y/W Yellow with White tracer

(For E34)

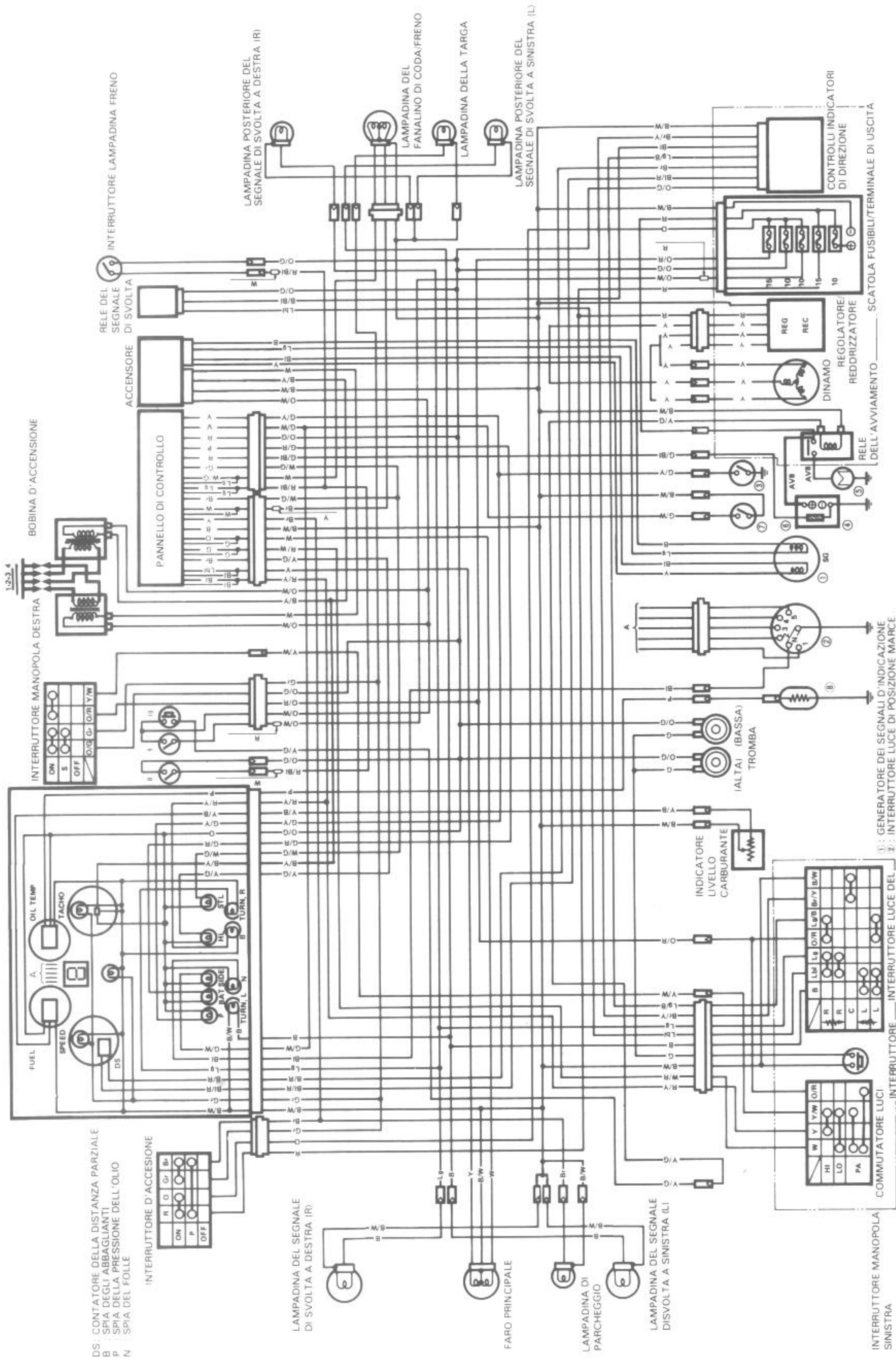

- COLORE DEIFIL**
- B Nero
 - Bl Blu
 - Br Marrone
 - G Verde
 - Gr Grigio
 - Lbl Blu chiaro
 - Lg Verde chiaro
 - O Arancione
 - P Rosa
 - R Rosso
 - V Violetto
 - W Bianco
 - Y Giallo
 - B/Bl Nero con traccia blu
 - B/R Nero con traccia rossa
 - B/W Nero con traccia bianca
 - B/Y Nero con traccia gialla
 - Br/R Nero con traccia rossa
 - Br/Y Blu con traccia rossa
 - G/Bl Marrone con traccia gialla
 - G/R Verde con traccia rossa
 - G/W Verde con traccia bianca
 - G/Y Verde con traccia gialla
 - Lg/Bl Verde chiaro con traccia blu
 - O/G Arancione con traccia verde
 - O/R Arancione con traccia rossa
 - O/W Arancione con traccia bianca
 - R/Bl Rosso con traccia blu
 - R/W Rosso con traccia bianca
 - R/Y Rosso con traccia gialla
 - W/G Bianco con traccia verde
 - W/R Bianco con traccia rossa
 - Y/Bl Giallo con traccia blu
 - Y/G Giallo con traccia verde
 - Y/W Giallo con traccia bianca

WIRE, CABLE AND HOSE ROUTING

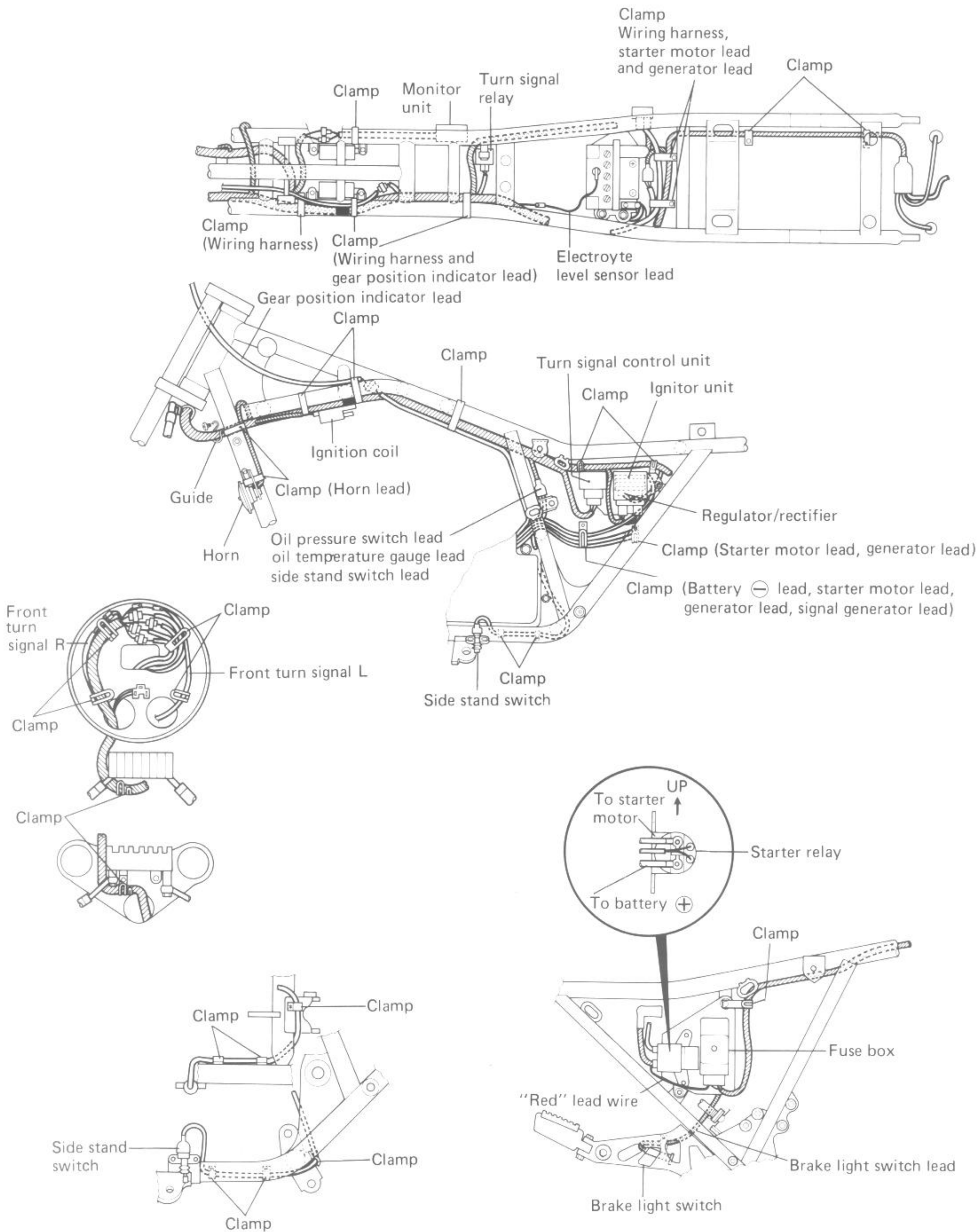

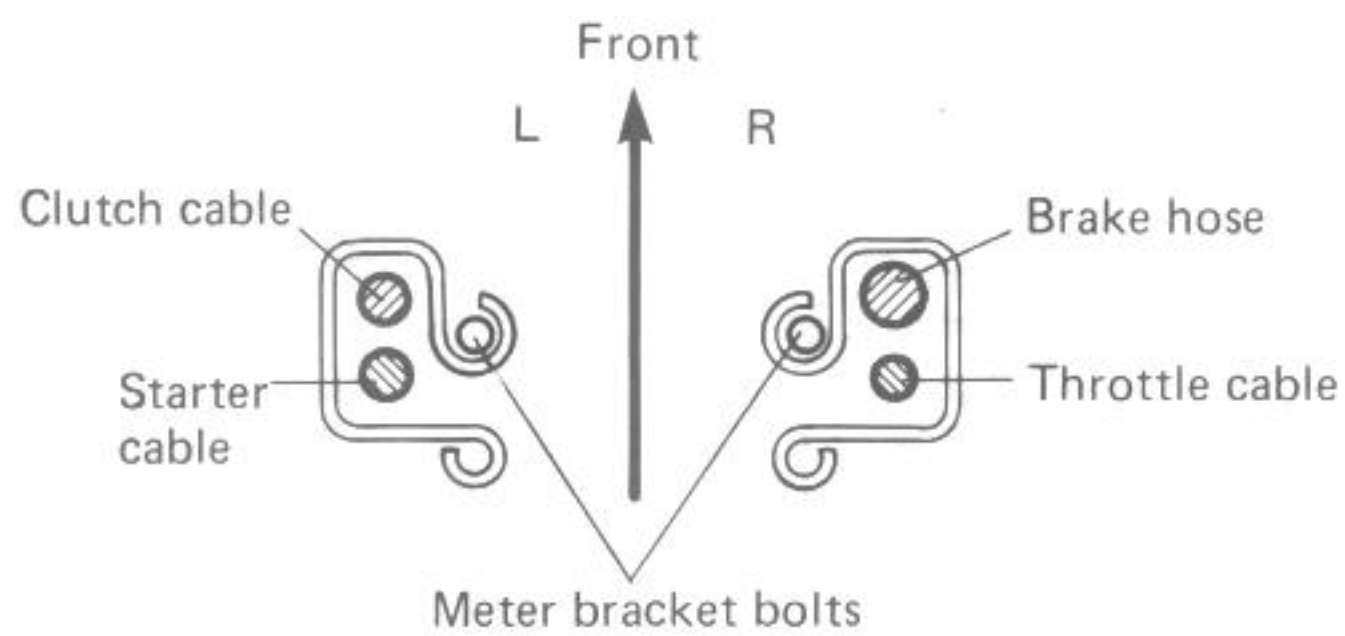
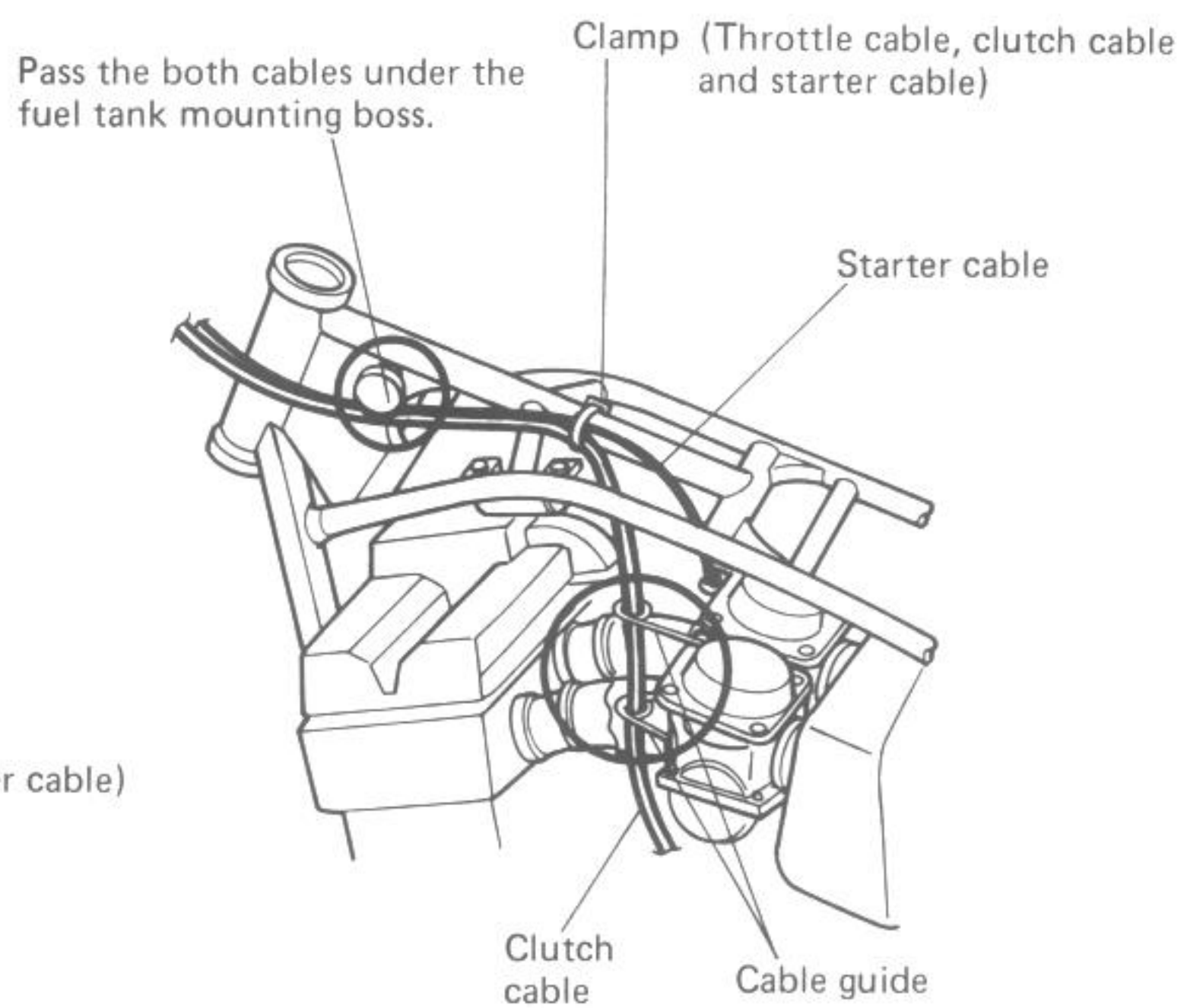
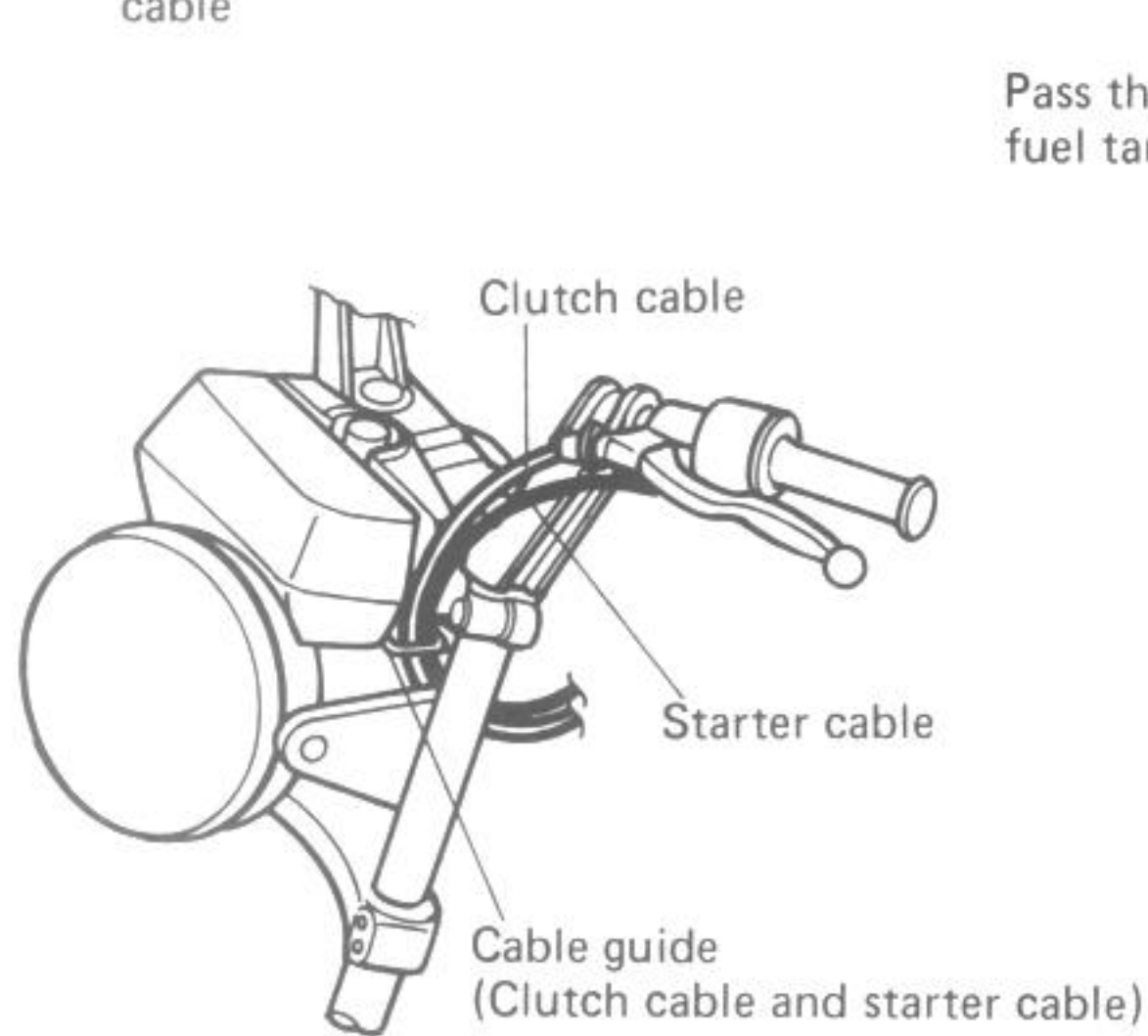
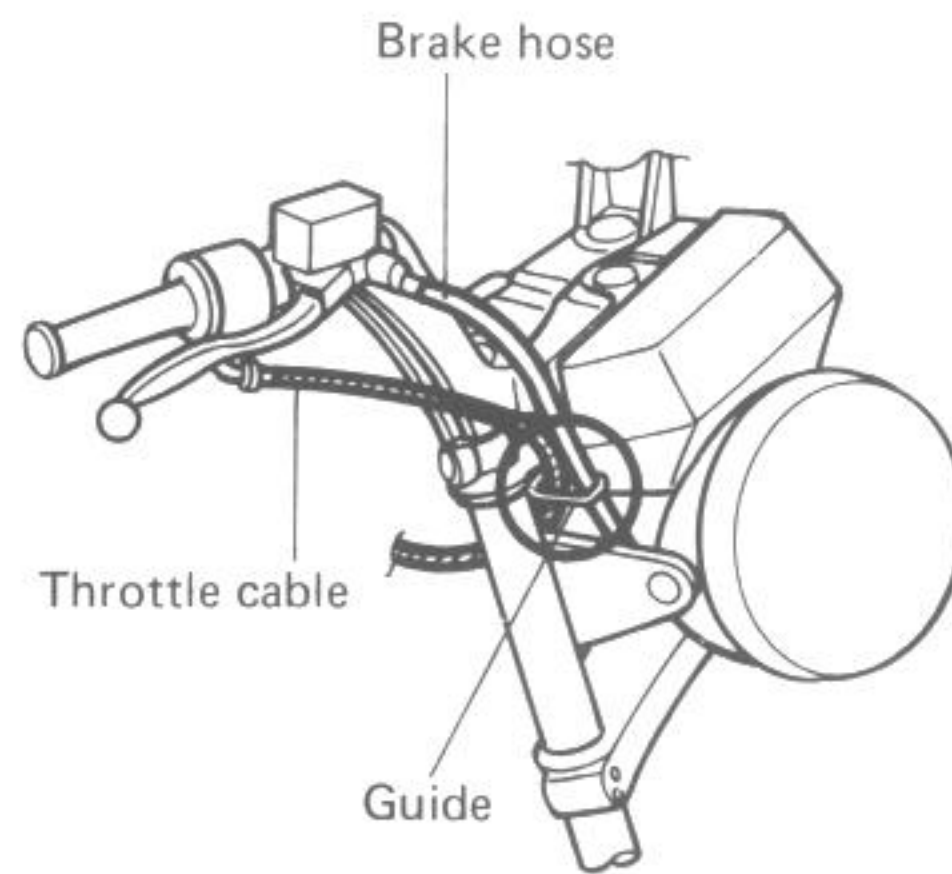
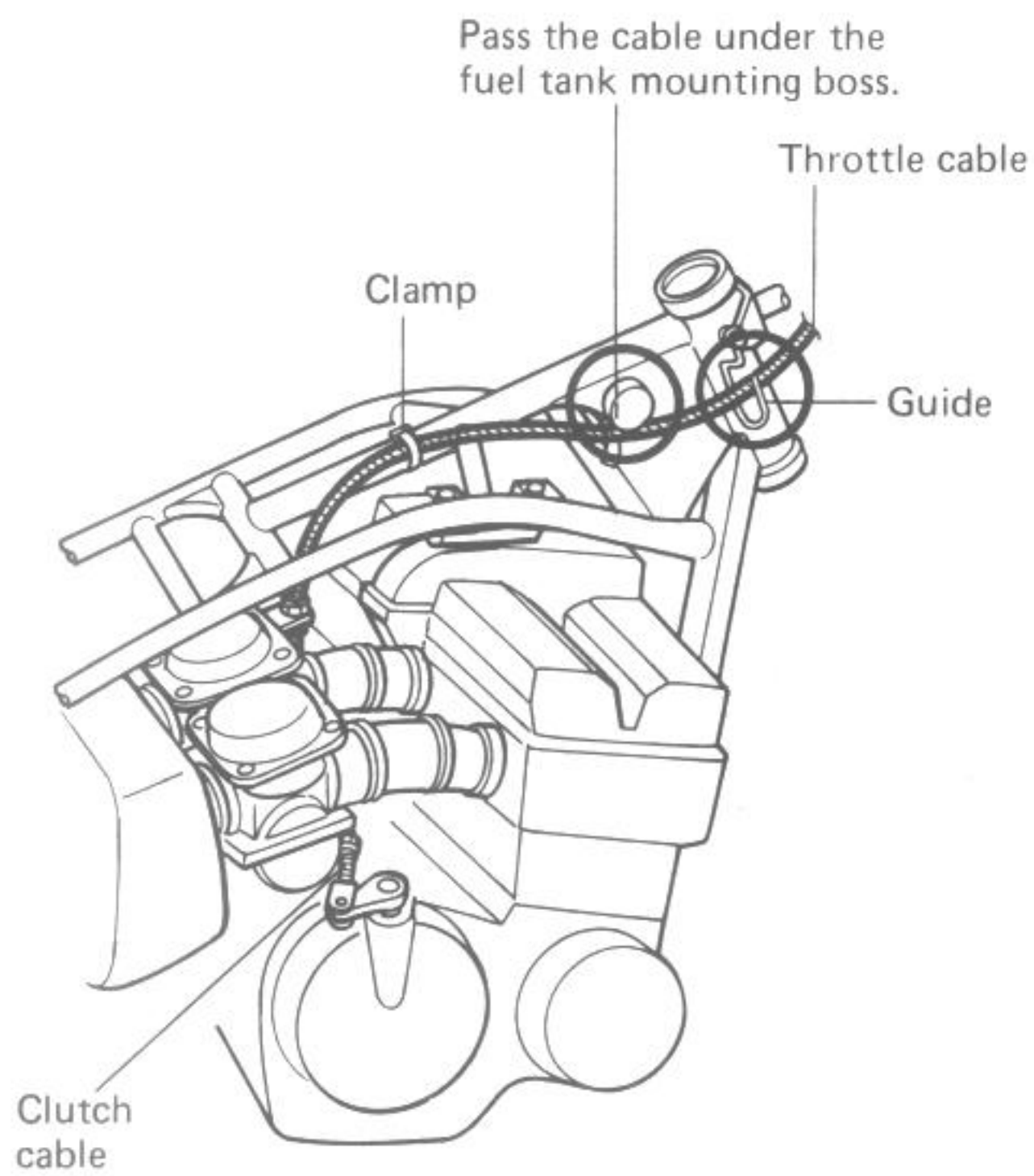

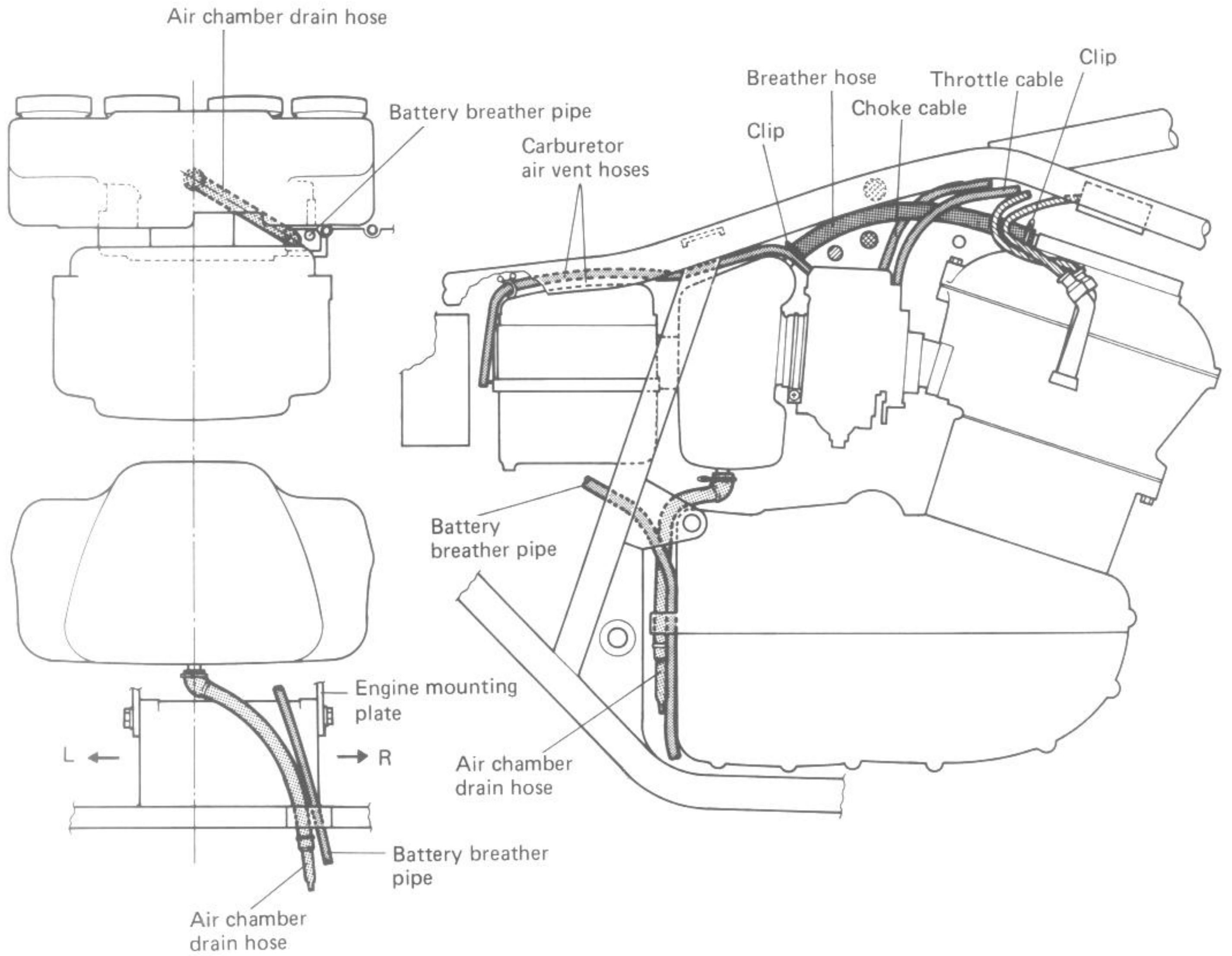
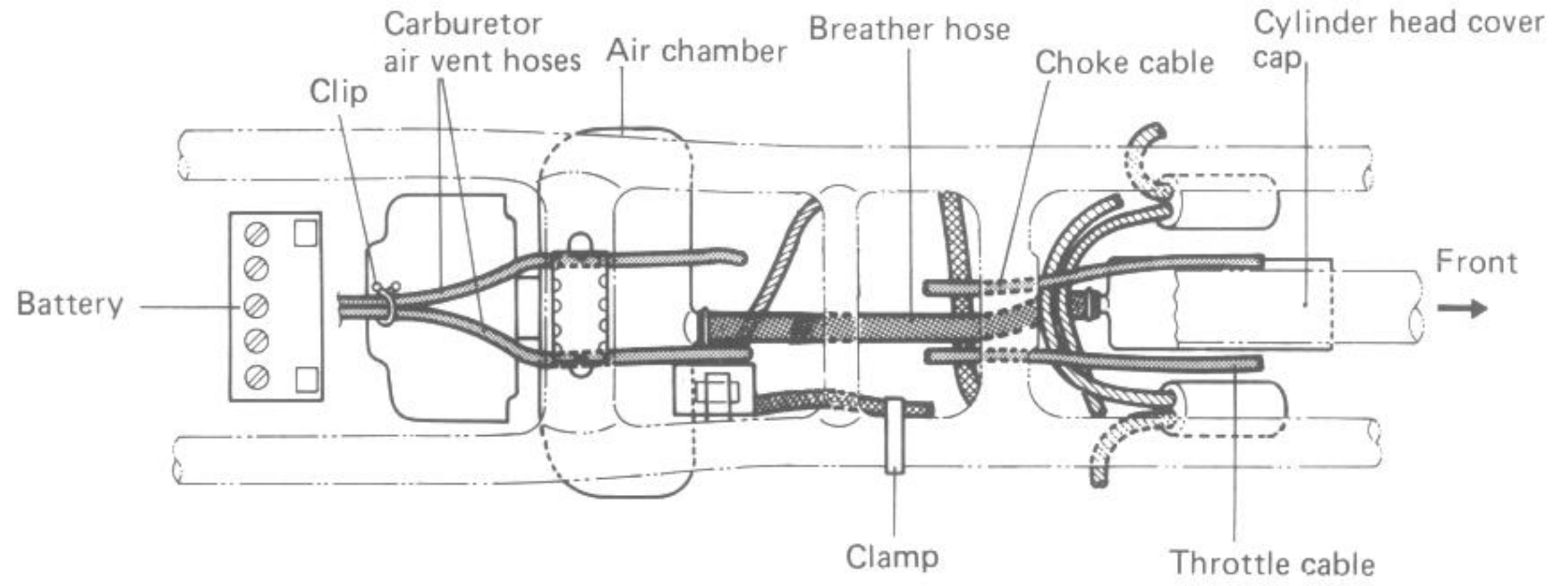

- Do not clamp the hose and cable with extended condition.
- After routing the hose and cable, make sure that the operation of each adjuster thrs smoothly.

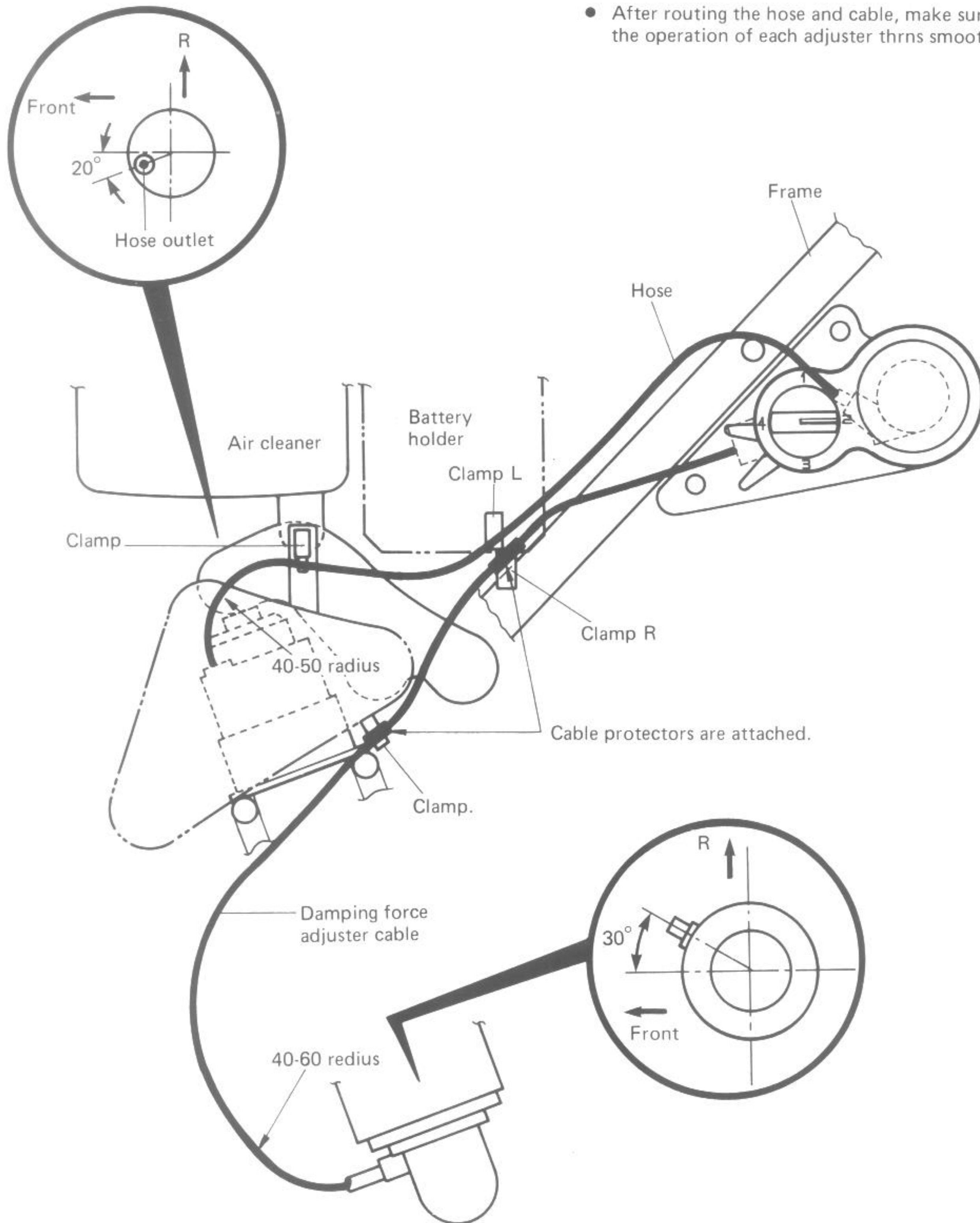

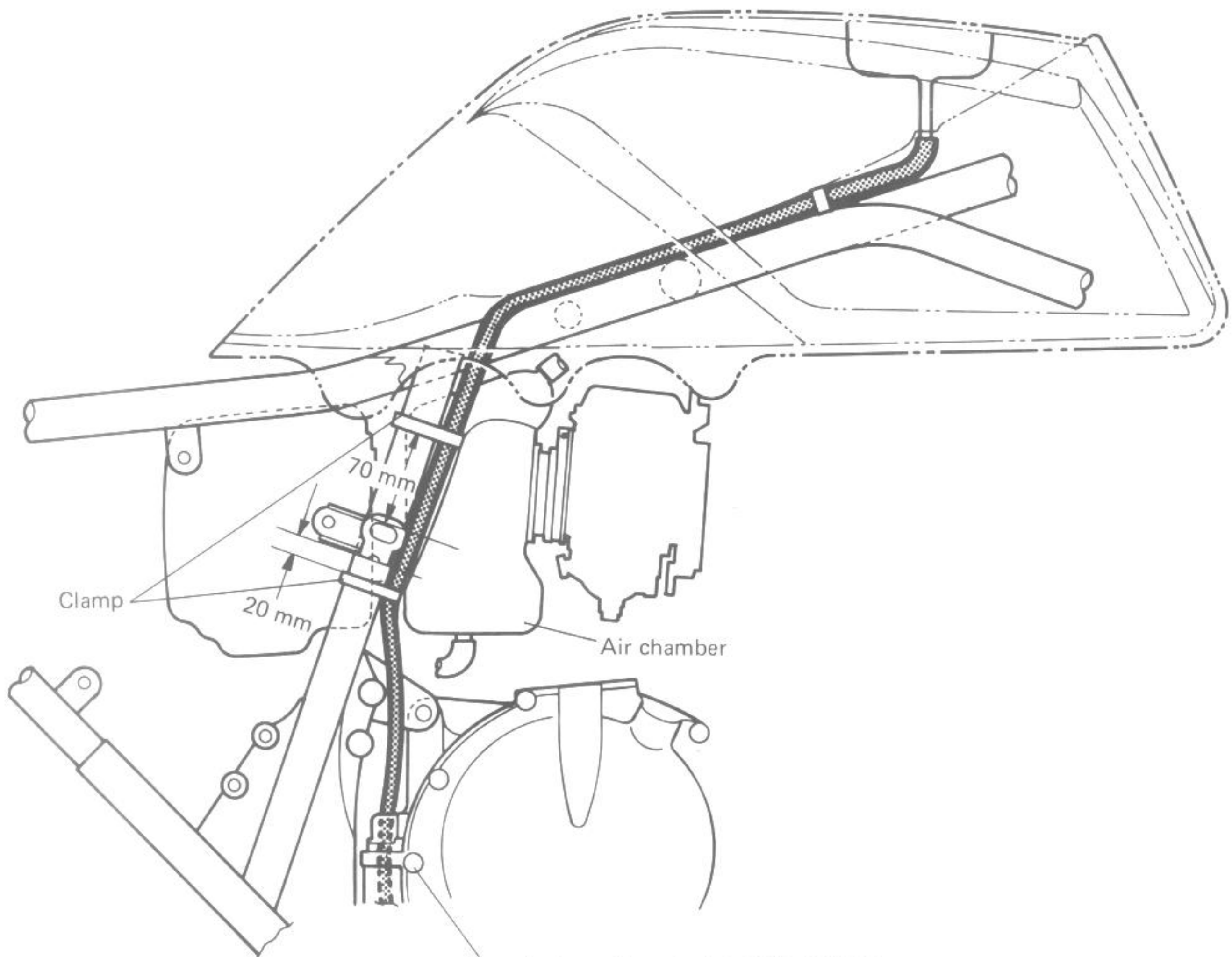
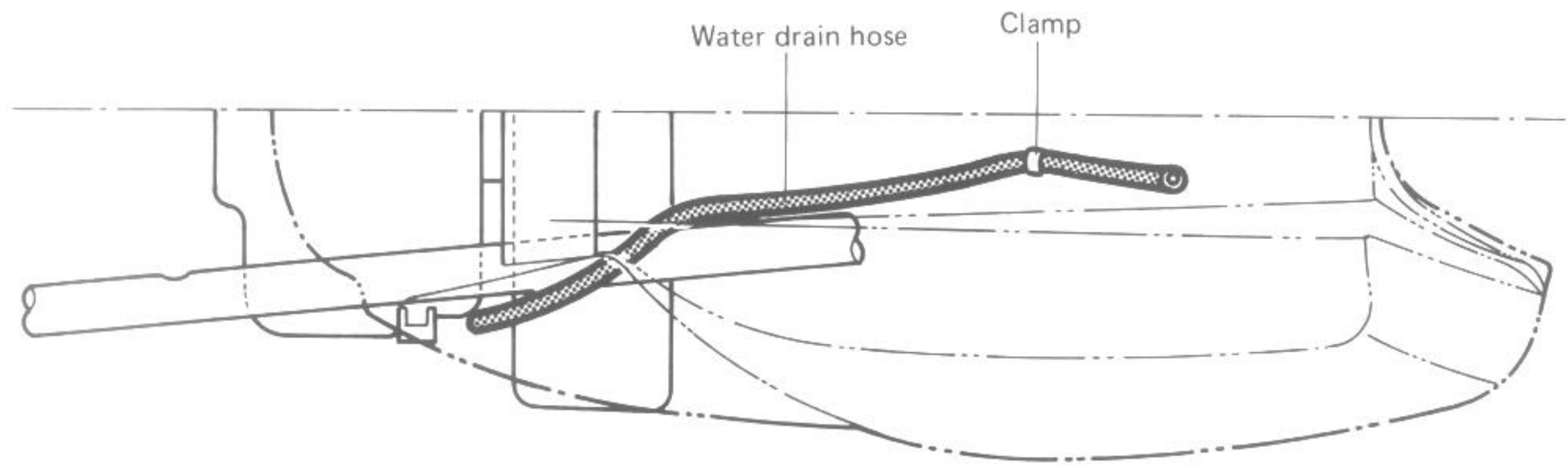

Pass the hose through the guide located on the crankcase.

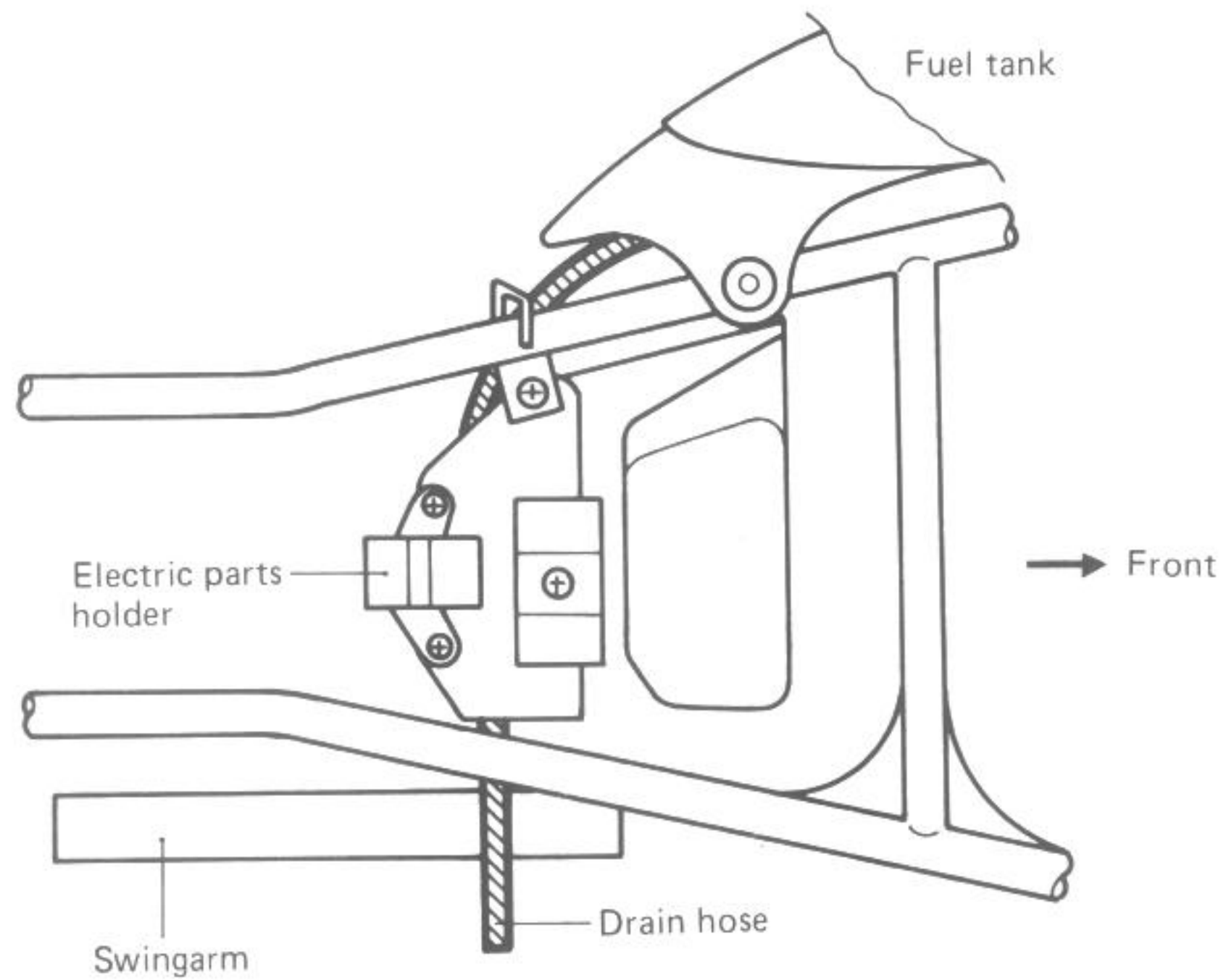
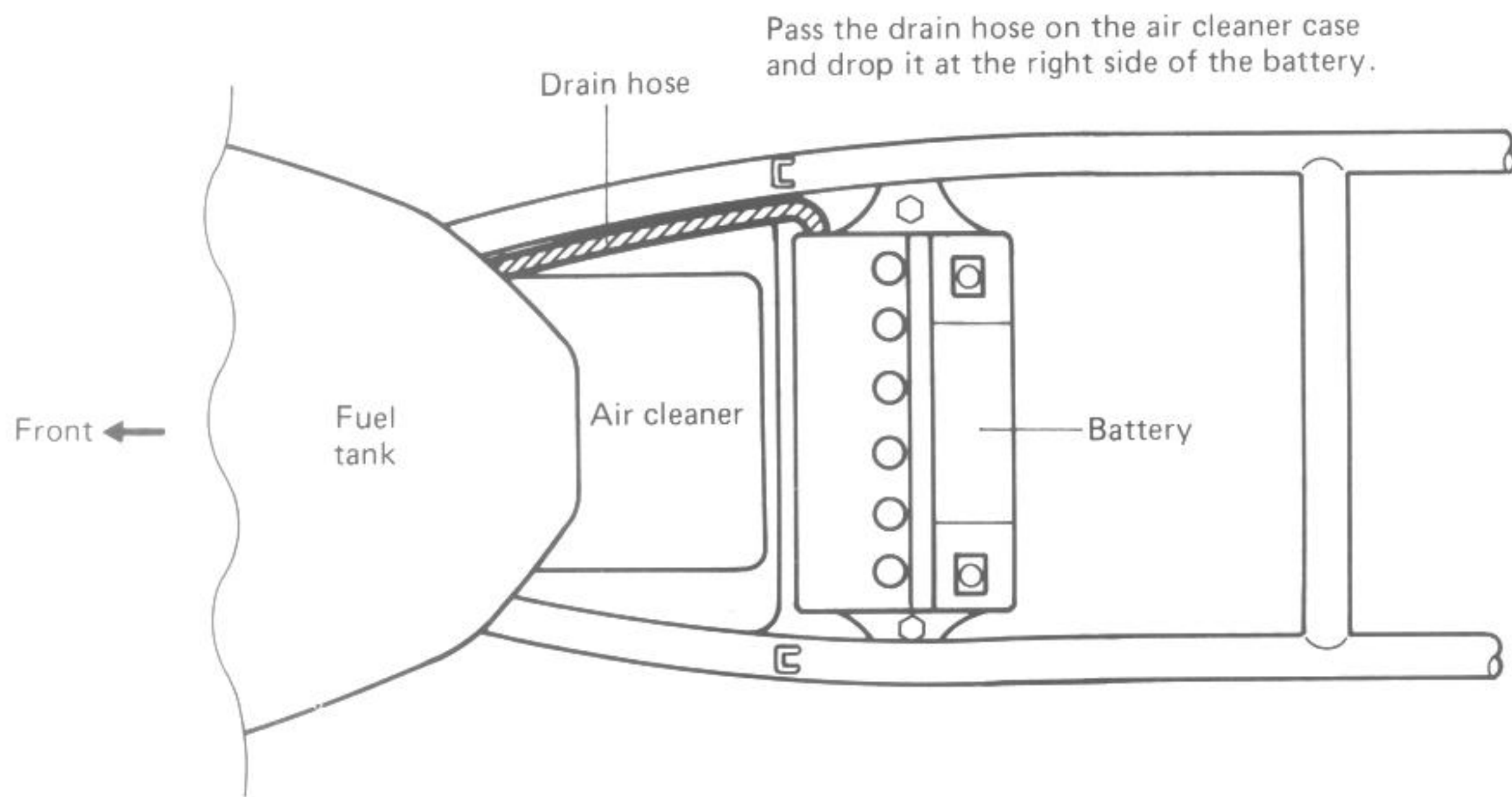

Pass the drain hose behind the electric parts holder and right side of the swing arm.

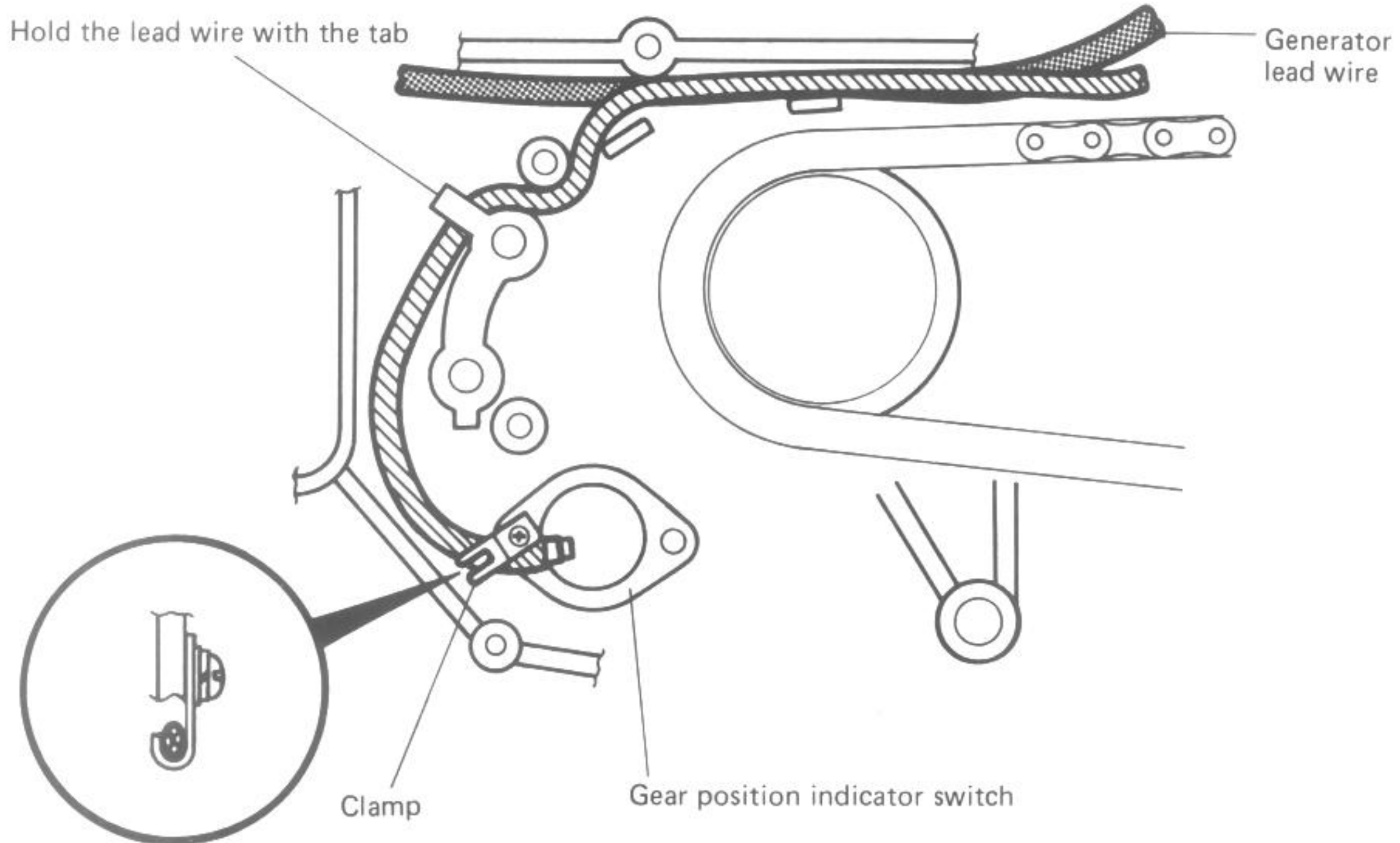
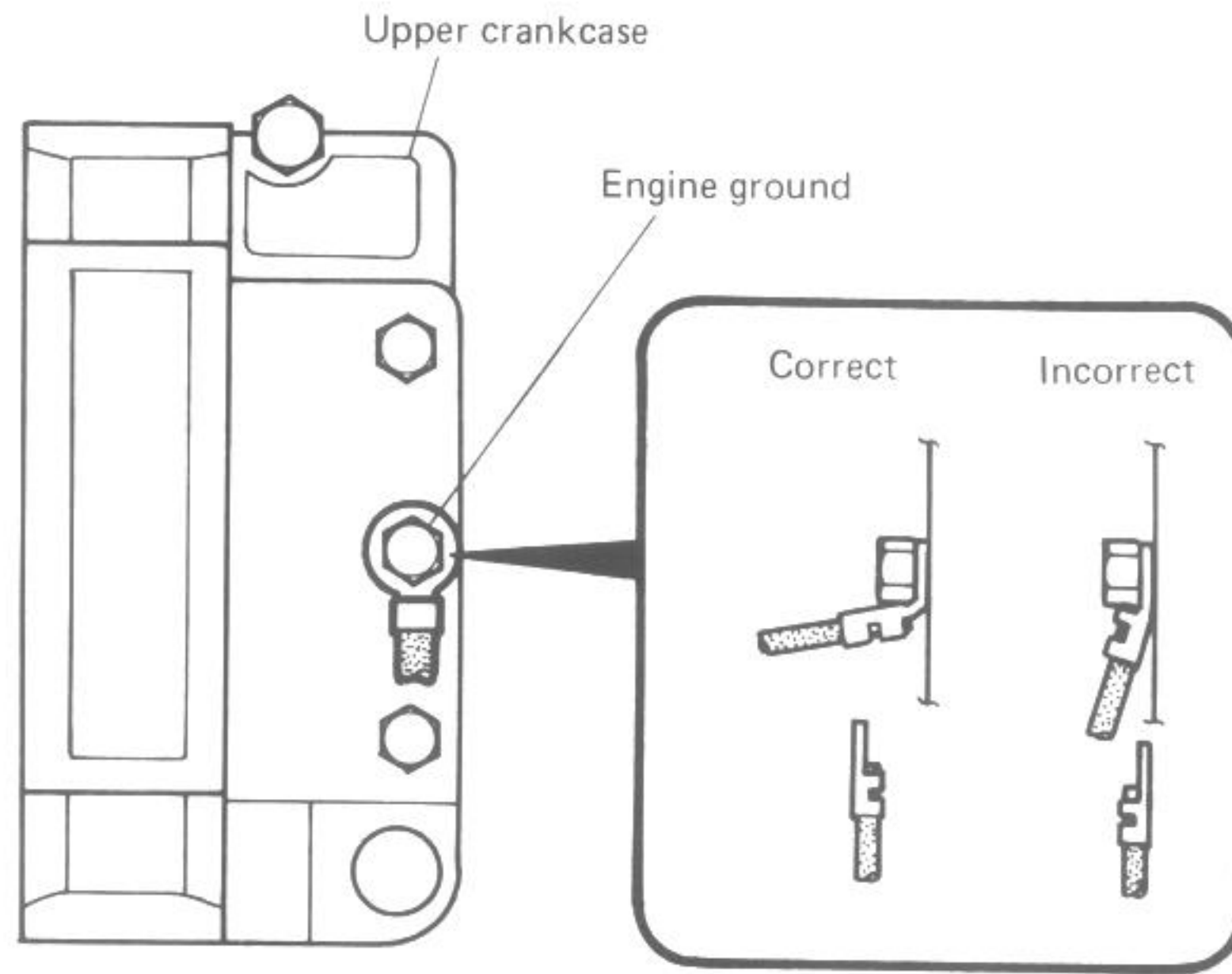

REAR TORQUE LINK

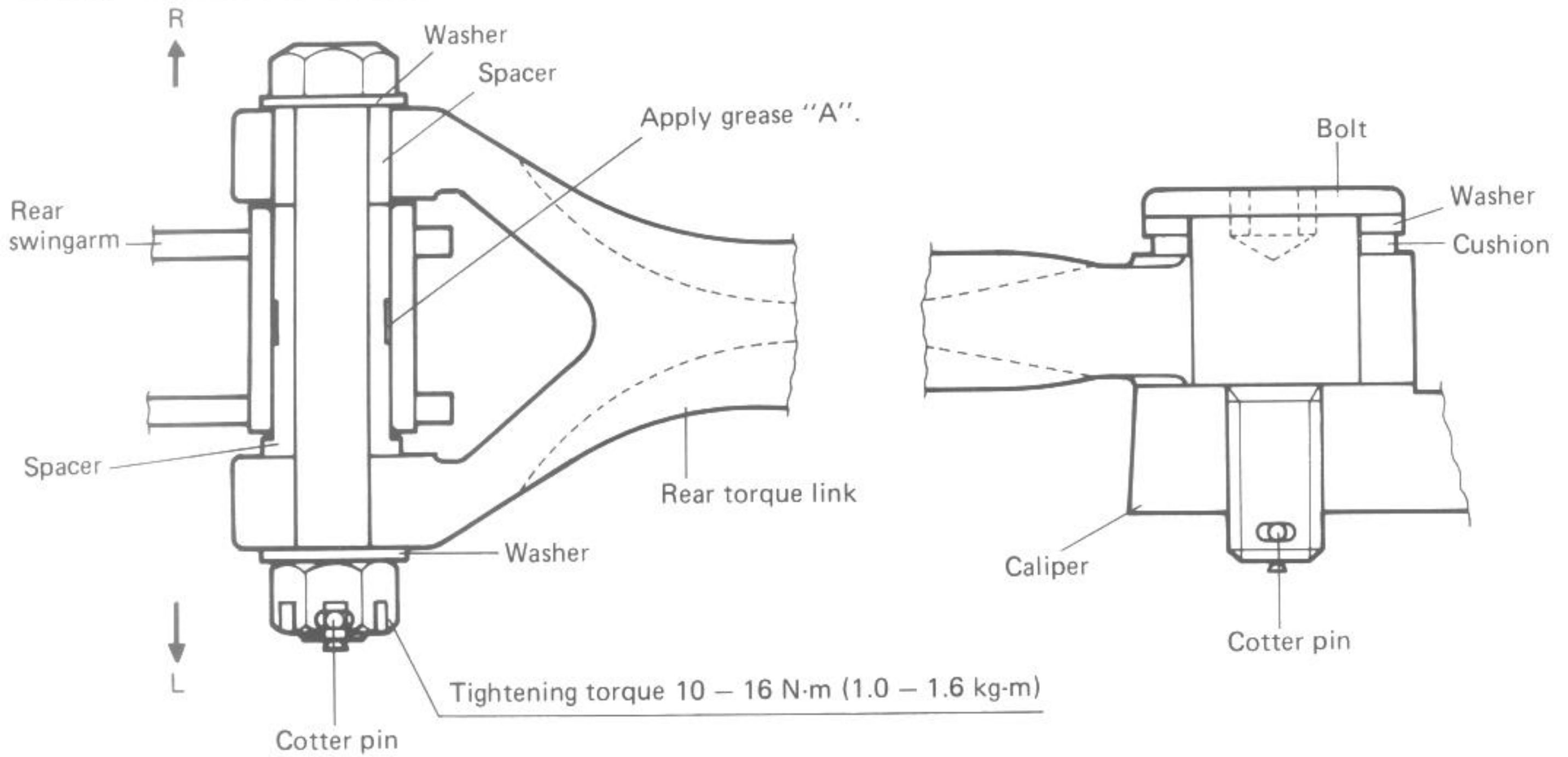

GREASING POINTS

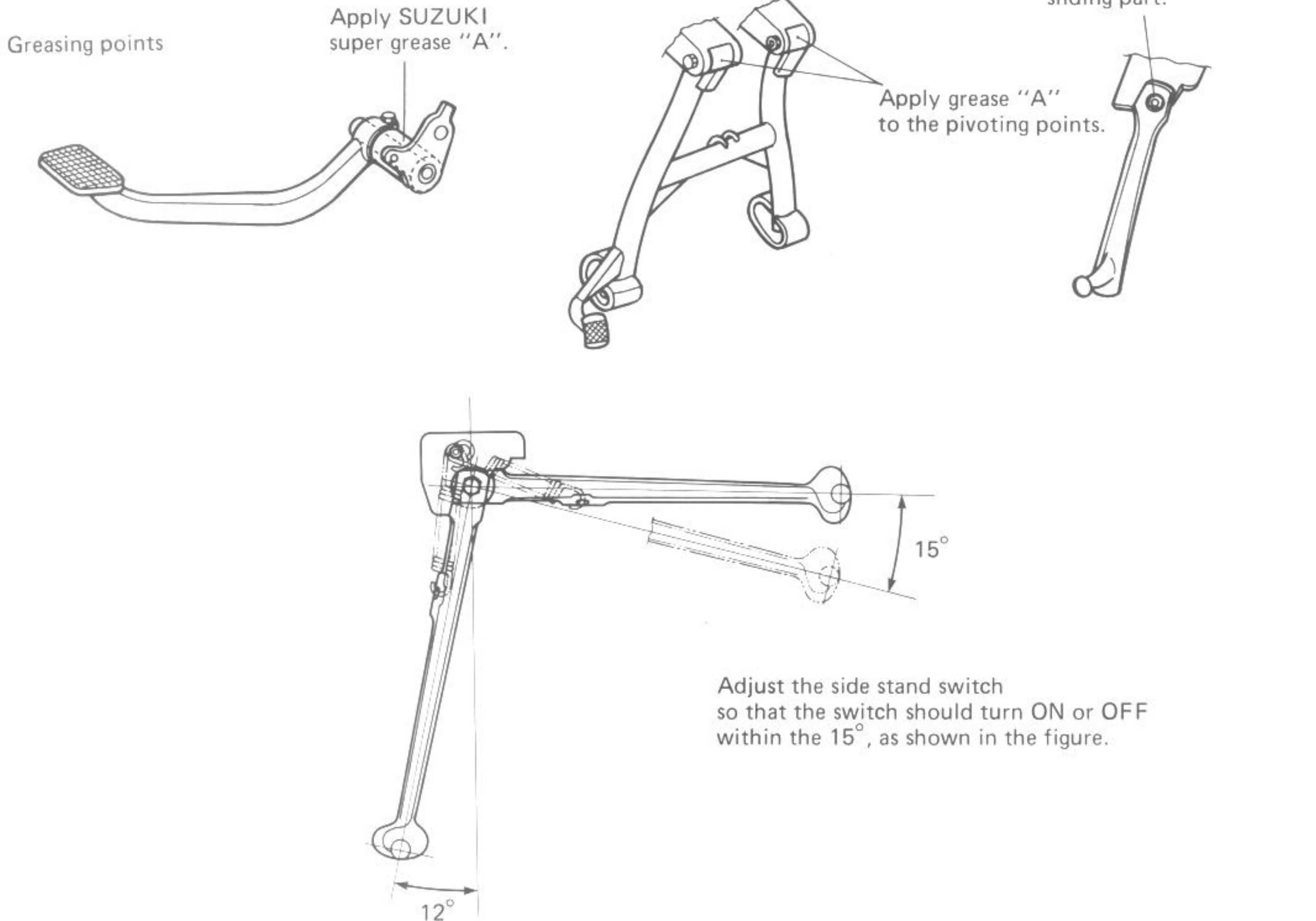

BRAKE HOSE ROUTING

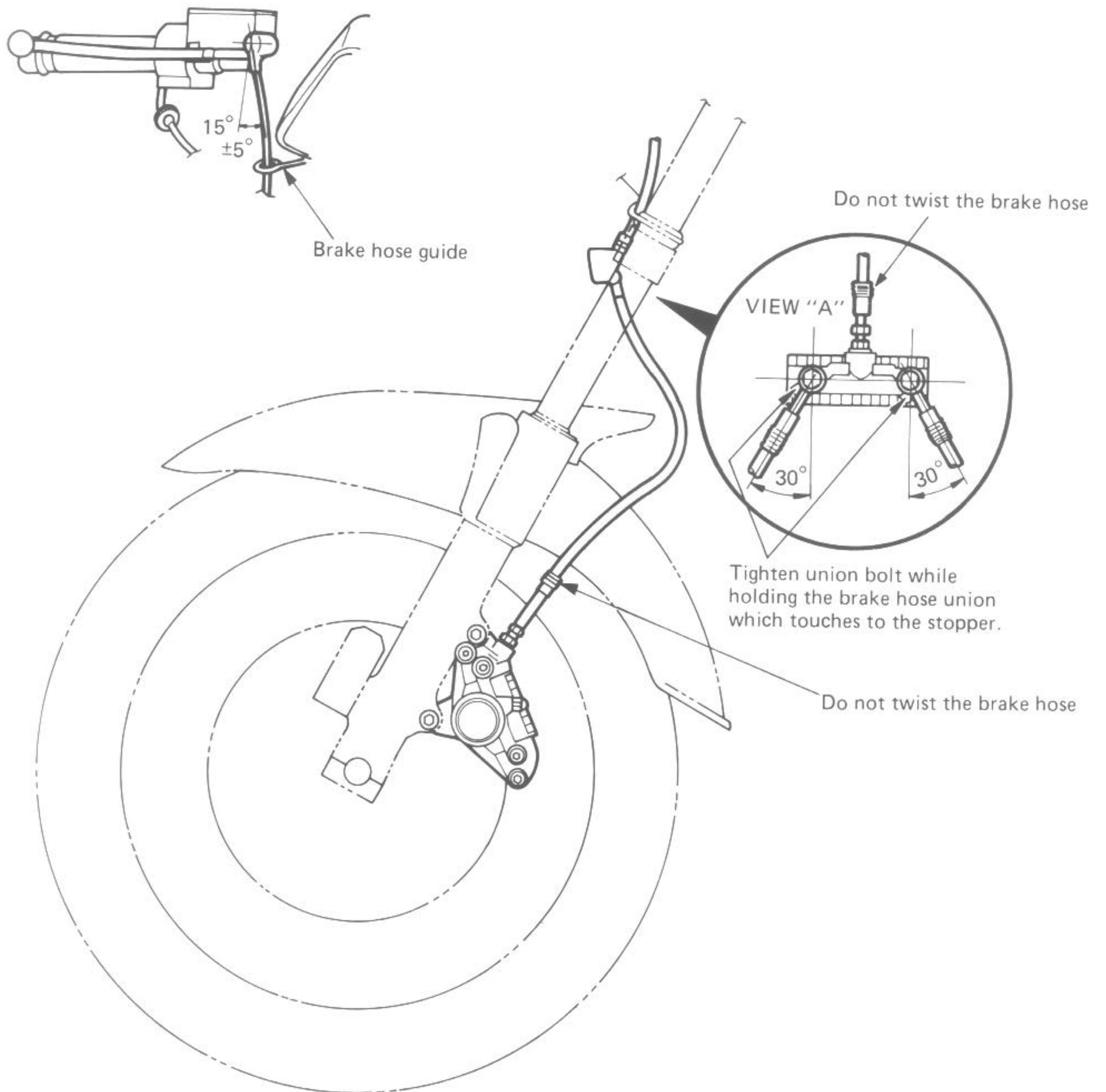
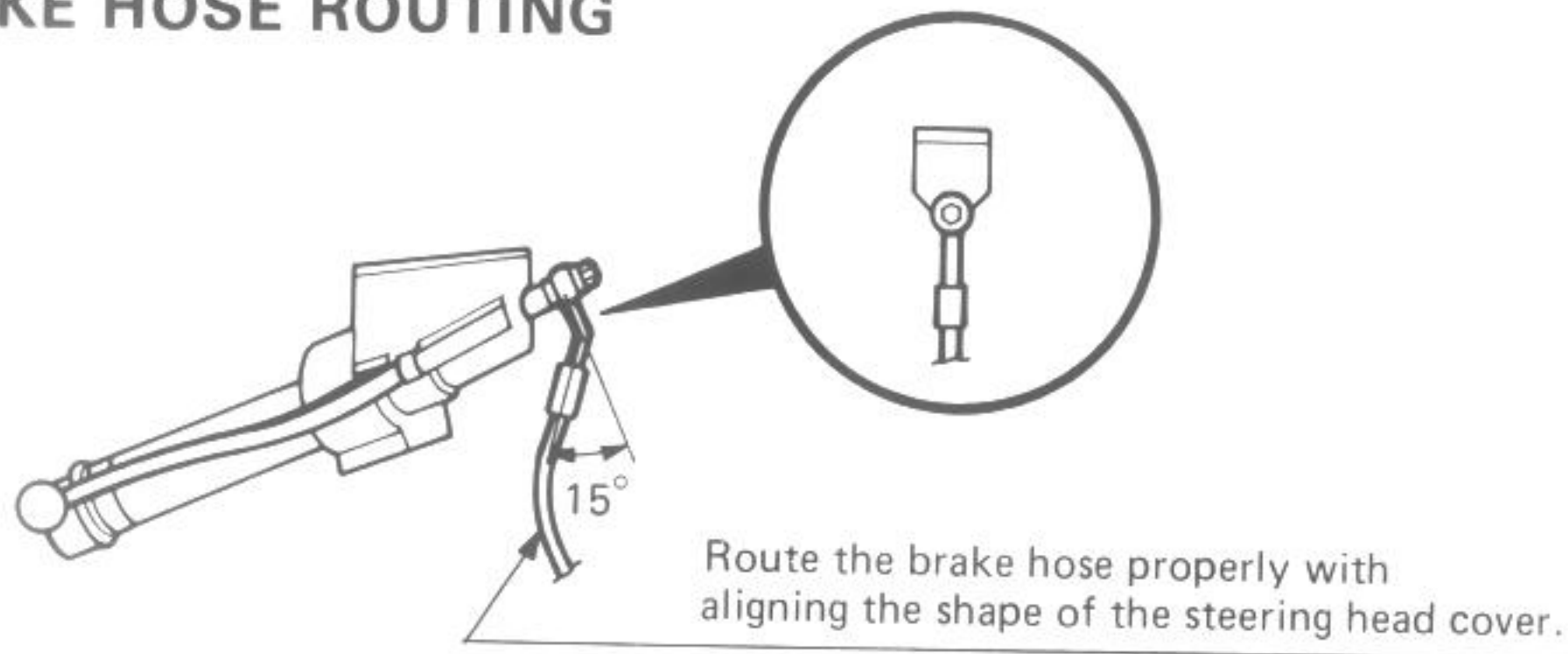

1. Turning radius of the brake hose should be more than 30 mm at the center of brake hose.
2. Hose winding should be less than 15° at the length of 300 mm.
3. Do not fix the hose to the caliper/master cylinder with the extended condition.
4. Make sure that no protective part does not contact with the other parts.

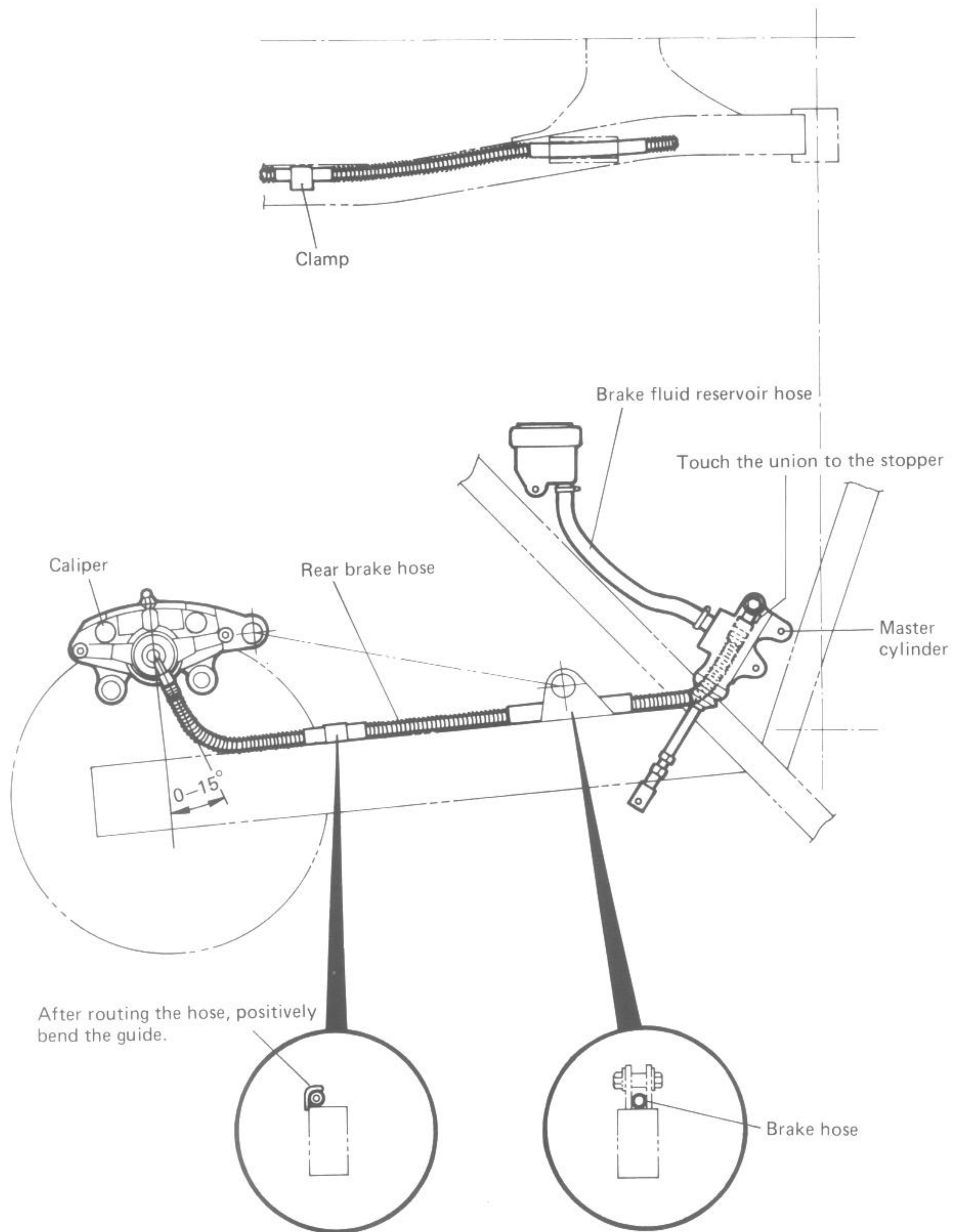

1. Turning radius of the brake hose should be more than 30 mm at the center of brake hose.
2. Hose winding should be less than 15° at the length of 300 mm.
3. Do not fix the hose to the caliper/master cylinder with the extended condition.
4. Make sure that no protective part does not contact with the other parts.

SPECIAL TOOLS

Item	Part No.	Part Name
1	09900-06105	Snap ring pliers (closing type)
2	09900-06107	Snap ring pliers
3	09900-06108	Snap ring pliers (closing type)
4	09900-09003	Impact driver set
5	09900-20102	Vernier calipers (200 mm)
6	09900-20205	Micrometer (0 – 25 mm)
	09900-20202	Micrometer (25 – 50 mm)
	09900-20203	Micrometer (50 – 75 mm)
7	09900-20508	Cylinder gauge set
8	09900-20602	Dial gauge (1/1000 mm)
	09900-20606	Dial gauge (1/100 mm)
9	09900-20701	Magnetic stand
10	09900-20803	Thickness gauge
	09900-20806	Thickness gauge (exclusive for valve clearance)
11	09900-21101	Torque wrench (0.5 – 4.5 kg-m)
	09900-21103	Torque wrench (1.0 – 9.0 kg-m)
12	09900-21303	V-block set (75 mm)
	09900-21304	V-block set (100 mm)
13	09900-22301	Plastigauge
14	09900-22401	Small bore gauge (10 – 18 mm)
	09900-22403	Small bore gauge (18 – 35 mm)
15	09900-25002	Pocket tester
16	09900-27311	Timing light
17	09900-28106	Electro tester
18	09900-28403	Hydrometer
19	09910-11510	Stud bolt installer (10 mm)
20	09910-20116	Conrod stopper
21	09910-34510	Piston pin puller
	Ⓐ 09910-33210	Attachment
22	09910-60611	Universal clamp wrench
23	09911-70130	4 mm hexagon wrench
24	09911-73730	"T" type hexagon wrench (5 mm)
	09914-25811	"T" type hexagon wrench (6 mm)
25	Ⓐ 09912-34510	Cylinder disassembling tool
26	09913-13121	Carburetor balancer set
	Ⓐ 09913-13140	Adapter
27	09913-14541	Fuel level gauge set
	Ⓐ 09913-14410	(16 mm x P1.0 screw)
	Ⓑ 09913-14530	(10 mm x P1.0 screw)
	Ⓒ 09913-14511	(6 mm x P0.75 screw)
28	09913-14911	Throttle valve adjust wrench
29	09913-50121	Oil seal remover
30	09913-75520	Bearing installer (60.5 mm)
31	09913-75820	Bearing installer (32 mm)
32	09913-80112	Bearing installer (34 mm)
33	09913-84510	Bearing installer (38 mm)
34	09915-64510	Compression gauge

Item	Part No.	Part Name
35	09915-63210	Compression gauge adaptor
36	09915-74510	Oil pressure gauge
37	09916-14510	Valve lifter
38	09916-14910	Valve lifter attachment
39	09916-21110	Valve seat cutter set
40	09916-34561	Ⓐ Valve guide hole reamer (11.3 mm)
	09916-34541	Ⓑ Reamer handle
	09916-34550	Ⓒ Valve guide reamer (5.5 mm)
41	09916-44910	Valve guide remover
42	09916-44920	Valve guide installer attachment
43	09916-74520	Piston ring holder body
	09916-74540	Band (63 – 75 mm)
44	09916-84510	Tweezers
45	09917-14910	Tappet adjust driver
46	09920-53710	Clutch sleeve hub holder
47	09923-74510	Bearing puller
48	09924-84510	Bearing installer set
49	09930-14511	Cylinder head nut and spark plug wrench set
	Ⓐ 09914-24510	“T” handle
	Ⓑ 09911-74510	Long socket (14 mm)
	Ⓒ 09911-74520	Long socket (12 mm)
	Ⓓ 09930-14530	Universal joint
	Ⓔ 09930-14520	Spark plug wrench (21 mm)
50	09930-13210	Spark plug socket wrench
51	09930-30102	Sliding shaft
52	09930-34930	Rotor remover
53	09930-44911	Rotor holder
54	09940-14911	Steering nut socket wrench
55	09940-34520	Front fork assembling “T” handle
	09940-34580	Attachment F
56	09940-44120	Front fork air pressure gauge (0 – 4.0 kg/cm ²)
57	09940-50112	Front fork oil seal installer (26 – 42 mm)
58	09941-34513	Steering race and swinging arm bearing installer
59	09941-44510	Swinging arm bearing remover
60	09941-50110	Bearing remover
61	09941-54911	Bearing inner race remover
62	09941-74910	Steering bearing installer
63	09941-84510	Bearing outer race remover
64	09941-94510	Rim protector
65	09943-74111	Front fork oil level gauge
66	96200-41330	Tire pressure gauge (0 – 3 kg/cm ²)

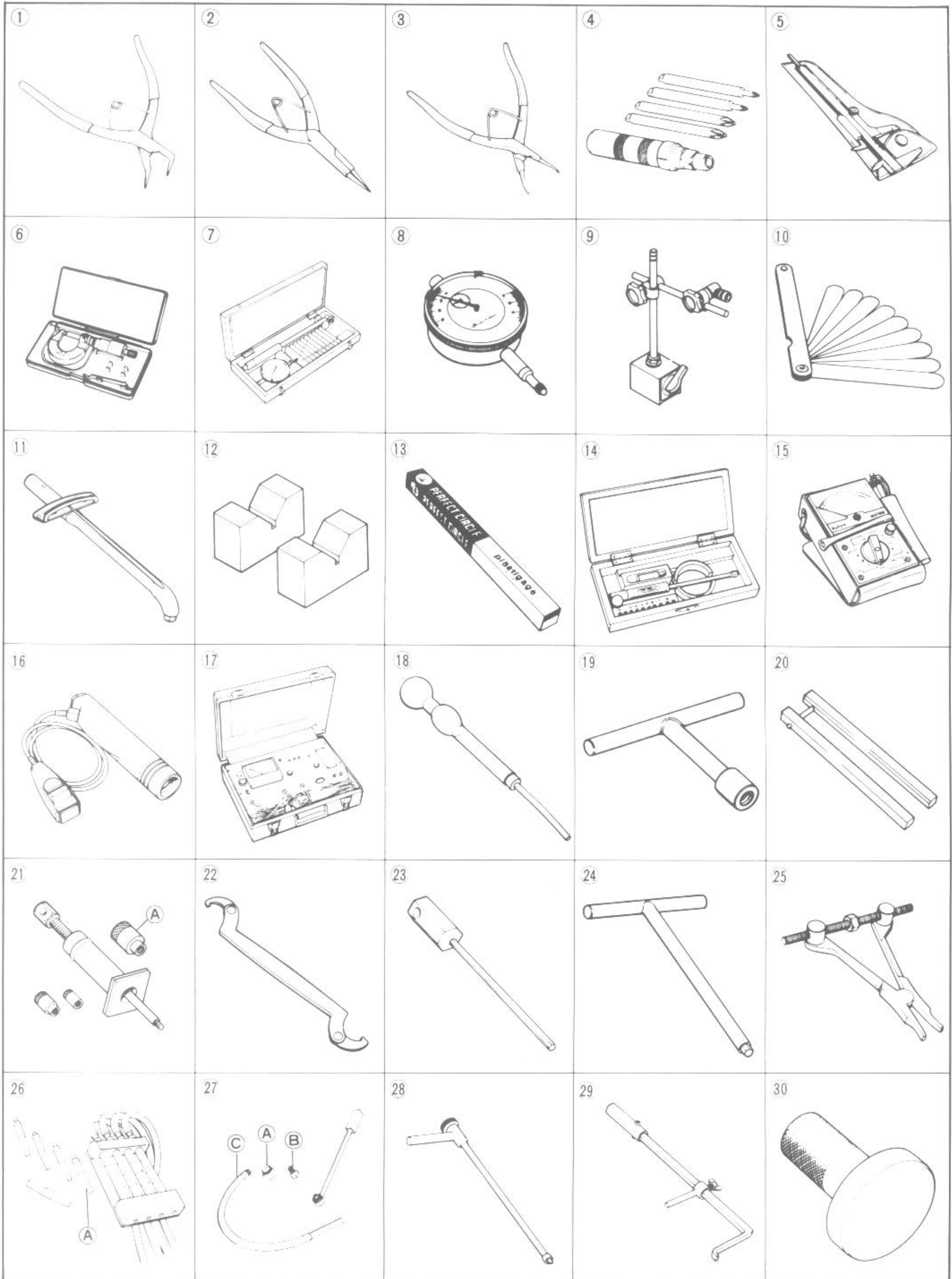

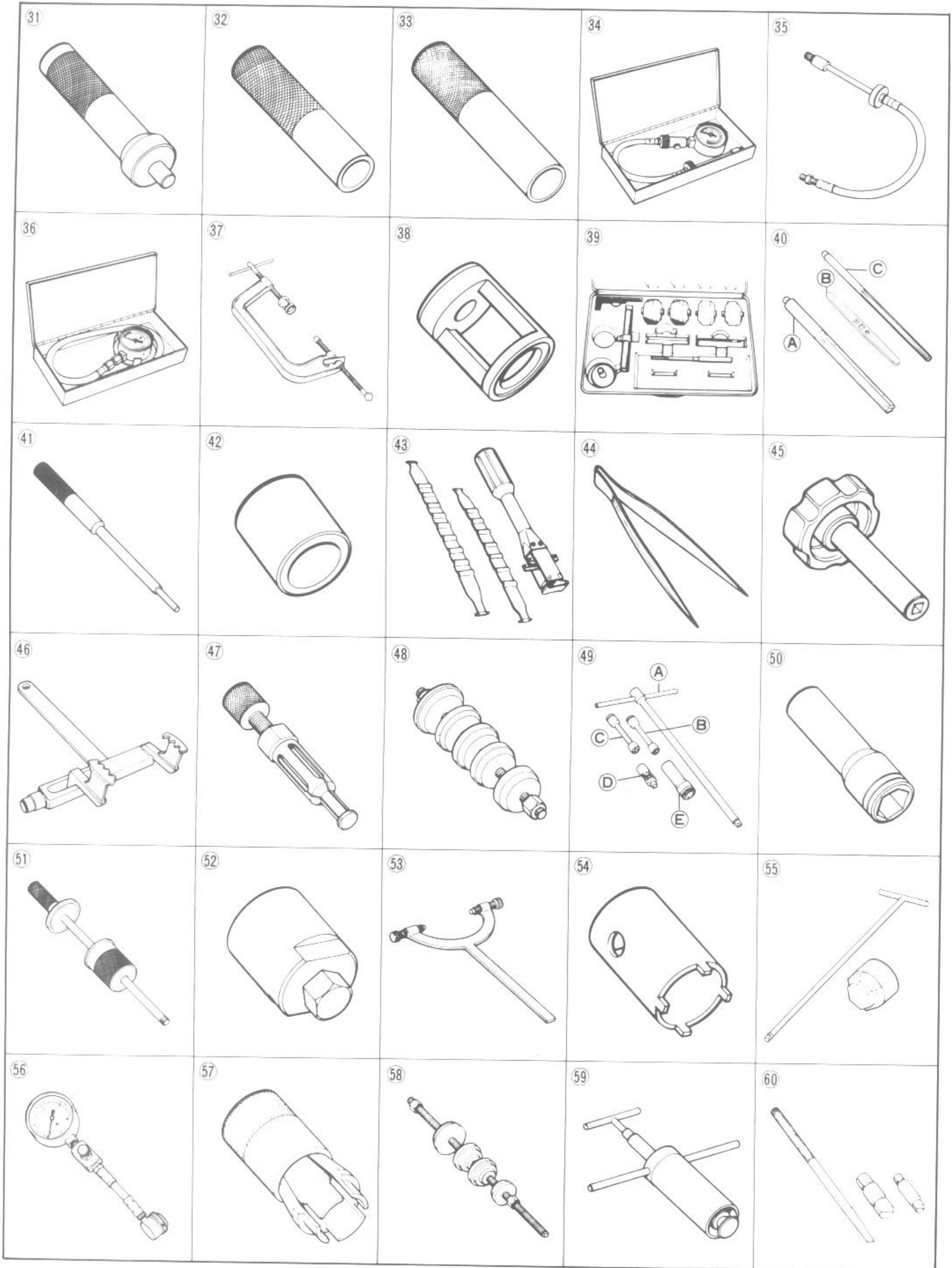

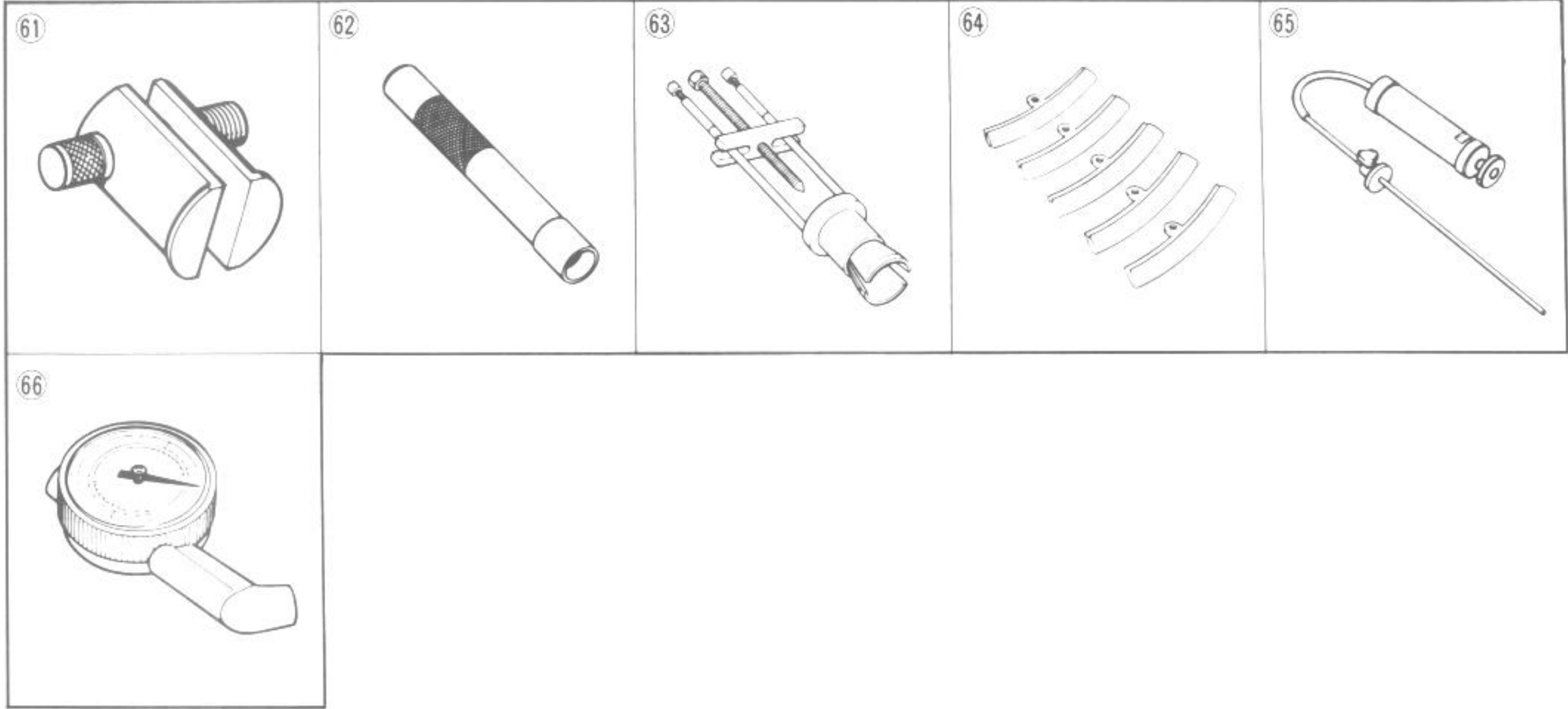

TORQUE TABLE**ENGINE**

Item	N·m	kg-m	lb-ft
Cylinder head cover bolt	13 – 15	1.3 – 1.5	9.5 – 11.0
Cylinder head bolt	7 – 11	0.7 – 1.1	5.0 – 8.0
Cylinder head nut	35 – 40	3.5 – 4.0	25.5 – 29.0
Rocker arm shaft stopper bolt	8 – 10	0.8 – 1.0	6.0 – 7.0
Valve clearance adjuster lock nut	9 – 11	0.9 – 1.1	6.5 – 8.0
Camshaft sprocket bolt	24 – 26	2.4 – 2.6	17.5 – 19.0
Cam chain tensioner fitting bolt	6 – 8	0.6 – 0.8	4.5 – 6.0
Cam chain tensioner shaft ass'y	30 – 35	3.0 – 3.5	21.5 – 25.5
Cam chain tensioner adjuster lock shaft nut	8 – 10	0.8 – 1.0	6.0 – 7.0
Cam chain guide bolt	9 – 14	0.9 – 1.4	6.5 – 10.0
Generator rotor nut	160 – 170	16.0 – 17.0	115.5 – 123.0
Starter clutch allen bolt	23 – 28	2.3 – 2.8	16.5 – 20.0
Signal generator rotor bolt	13 – 23	1.3 – 2.3	9.5 – 16.5
Crankcase bolt (6 mm)	9 – 13	0.9 – 1.3	6.5 – 9.5
Crankcase bolt (8 mm)	20 – 24	2.0 – 2.4	14.5 – 17.0
Starter motor bolt	4 – 7	0.4 – 0.7	3.0 – 5.0
Oil pan bolt	10	1.0	7.0
Oil filter cover nut	6 – 8	0.6 – 0.8	4.5 – 6.0
Neutral cam stopper bolt	18 – 28	1.8 – 2.8	13.0 – 20.0
Gearshift arm stopper	15 – 23	1.5 – 2.3	11.0 – 16.5
Clutch sleeve hub nut	50 – 70	5.0 – 7.0	36.0 – 50.5
Clutch spring bolt	11 – 13	1.1 – 1.3	8.0 – 9.5
Engine sprocket nut	100 – 150	10.0 – 15.0	72.5 – 108.5
Engine mounting nut A (290 mm)	70 – 88	7.0 – 8.8	50.5 – 63.5
Engine mounting nut B (180 mm)	70 – 88	7.0 – 8.8	50.5 – 63.5
Engine mounting nut C (165 mm)	55 – 66	5.5 – 6.6	40.0 – 47.5
Engine mounting bolt D (60 mm)	50 – 60	5.0 – 6.0	36.0 – 43.5
Gearshift lever bolt	13 – 23	1.3 – 2.3	9.5 – 16.5
Clutch release arm bolt	6 – 10	0.6 – 1.0	4.5 – 7.0
Exhaust pipe clamp bolt	20 – 25	2.0 – 2.5	14.5 – 18.0
Oil hose union bolt	25 – 30	2.5 – 3.0	18.0 – 21.5
Oil pump bolt	7 – 9	0.7 – 0.9	5.0 – 6.5
Oil drain bolt	20 – 25	2.0 – 2.5	14.5 – 18.0
Oil gallery plug	30 – 40	3.0 – 4.0	21.5 – 29.0
Cylinder stud bolt	10 – 16	1.0 – 1.6	7.0 – 11.5
Cylinder stud bolt (No. 2, 4, 6, 7, 8)	16	1.6	11.5

CHASSIS

Item	N·m	kg-m	lb-ft
Disc bolt	15 – 25	1.5 – 2.5	11.0 – 18.0
Front axle nut	36 – 52	3.6 – 5.2	26.0 – 37.5
Front axle holder nut	15 – 25	1.5 – 2.5	11.0 – 18.0
Front caliper mounting bolt	25 – 40	2.5 – 4.0	18.0 – 29.0
Front caliper housing bolt	18 – 23	1.8 – 2.3	13.0 – 16.5
Brake hose union bolt	20 – 25	2.0 – 2.5	14.5 – 18.0
Caliper air bleeder	6 – 9	0.6 – 0.9	4.5 – 6.5
Front fork damper rod bolt	20 – 25	2.0 – 2.5	14.5 – 18.0
Air joint nut	10 – 13	1.0 – 1.3	7.0 – 9.5
Front fork lower clamp bolt	15 – 25	1.5 – 2.5	11.0 – 18.0
Front fork upper clamp bolt	20 – 30	2.0 – 3.0	14.5 – 21.5
Front fork cap bolt	15 – 30	1.5 – 3.0	11.0 – 21.5
Posi-damp unit bolt	6 – 8	0.6 – 0.8	4.5 – 6.0
Headlamp housing bracket bolt	9 – 13	0.9 – 1.3	6.5 – 9.5
Steering stem nut	40 – 50	4.0 – 5.0	29.0 – 36.0
Steering stem clamp bolt	15 – 25	1.5 – 2.5	11.0 – 18.0
Steering stem head bolt	20 – 30	2.0 – 3.0	14.5 – 21.5
Handlebar clamp bolt	50 – 60	5.0 – 6.0	36.0 – 43.5
Handlebar holder nut	20 – 30	2.0 – 3.0	14.5 – 21.5
Handlebar set bolt	15 – 25	1.5 – 2.5	11.0 – 18.0
Front master cylinder clamp bolt	5 – 8	0.5 – 0.8	3.5 – 6.0
Front footrest bolt	27 – 43	2.7 – 4.3	19.5 – 31.0
Swing arm pivot nut	50 – 80	5.0 – 8.0	36.0 – 58.0
Brake pedal arm bolt	15 – 25	1.5 – 2.5	11.0 – 18.0
Rear master cylinder mounting bolt	15 – 25	1.5 – 2.5	11.0 – 18.0
Rear master cylinder rod lock nut	15 – 25	1.5 – 2.5	11.0 – 18.0
Rear torque link nut	20 – 30	2.0 – 3.0	14.5 – 21.5
Rear caliper mounting bolt	25 – 40	2.5 – 4.0	18.0 – 29.0
Rear caliper housing bolt	18 – 23	1.8 – 2.3	13.0 – 16.5
Rear shock absorber fitting nut	48 – 72	4.8 – 7.2	34.5 – 52.0
Rear cushion rod bolt (upper and lower)	84 – 100	8.4 – 10.0	61.0 – 72.5
Cushion lever shaft bolt	84 – 100	8.4 – 10.0	61.0 – 72.5
Cushion lever bracket bolt	70 – 100	7.0 – 10.0	50.5 – 72.5
Rear sprocket nut	25 – 40	2.5 – 4.0	18.0 – 29.0
Rear axle nut	85 – 115	8.5 – 11.5	61.5 – 83.0

shaft O.D.
distortion

TIGHTENING TORQUE CHART

For other bolts and nuts not listed, refer to this chart:

Bolt Diameter Ⓐ (mm)	Conventional or "4" marked bolt			"7" marked bolt		
	kg-m	lb-ft	N·m	kg-m	lb-ft	N·m
4	0.1 – 0.2	0.7 – 1.5	1.0 – 2.0	0.15 – 0.3	1.0 – 2.0	1.5 – 3.0
5	0.2 – 0.4	1.5 – 3.0	2.0 – 4.0	0.3 – 0.6	2.0 – 4.5	3.0 – 6.0
6	0.4 – 0.7	3.0 – 5.0	4.0 – 7.0	0.8 – 1.2	6.0 – 8.5	8.0 – 12.0
8	1.0 – 1.6	7.0 – 11.5	10.0 – 16.0	1.8 – 2.8	13.0 – 20.0	18.0 – 28.0
10	2.2 – 3.5	16.0 – 25.5	22.0 – 35.0	4.0 – 6.0	29.0 – 43.5	40.0 – 60.0
12	3.5 – 5.5	25.5 – 40.0	35.0 – 55.0	7.0 – 10.0	50.5 – 72.5	70.0 – 100.0
14	5.0 – 8.0	36.0 – 58.0	50.0 – 80.0	11.0 – 16.0	79.5 – 115.5	110.0 – 160.0
16	8.0 – 13.0	58.0 – 94.0	80.0 – 130.0	17.0 – 25.0	123.0 – 181.0	170.0 – 250.0
18	13.0 – 19.0	94.0 – 137.5	130.0 – 190.0	20.0 – 28.0	144.5 – 202.5	200.0 – 280.0

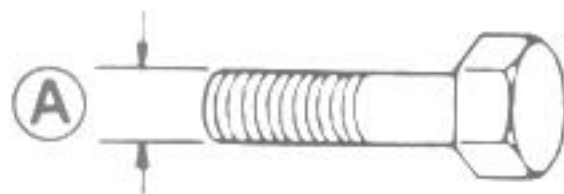

Conventional bolt

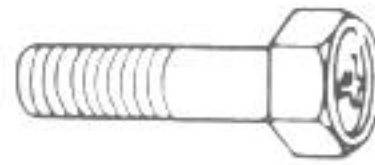

"4" Marked bolt

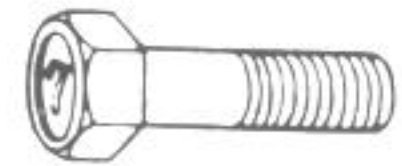

"7" Marked bolt

SERVICE DATA**VALVE + GUIDE**

Unit: mm

ITEM		STANDARD		LIMIT
Valve diam.		IN.	28.0	—
		EX.	23.0	—
Valve lift		E-17,18		—
		22,39		—
		The others		—
				—
Valve clearance (when cold)		IN. & EX.	0.08–0.13	—
Valve stem deflection		IN.	—	0.35
		EX.	—	0.35
Valve guide I.D.		IN. & EX.	5.500–5.512	—
Valve stem O.D.		IN.	5.470–5.487	—
		EX.	5.445–5.460	—
Valve stem runout		IN. & EX.	—	0.05
Valve head thickness		IN. & EX.	—	0.5
Valve stem end length		IN. & EX.	—	3.8
Valve seat width		IN. & EX.	0.9–1.1	—
Valve head radial runout		IN. & EX.	—	0.03
Valve spring free length (IN. & EX.)		INNER	—	31.9
		OUTER	—	35.6
Valve spring tension (IN. & EX.)		INNER	4.9–5.8 kg at length 28.5 mm	—
		OUTER	7.2–8.1 kg at length 32.0 mm	—

CAMSHAFT + CYLINDER HEAD

Unit: mm

ITEM		STANDARD		LIMIT
Cam height		E-17,18		—
		22,39		—
		The others		—
				—
Camshaft journal oil clearance		IN. & EX.	—	0.150
Camshaft journal holder I.D.		IN. & EX.	22.012–22.025	—
Camshaft journal O.D.		IN. & EX.	21.959–21.980	—
Camshaft runout		IN. & EX.	—	0.10
Cam chain 20-pitch length			—	157.80
Cam chain pin (at arrow "3")			20 th pin	—
Rocker arm I.D.		IN. & EX.	12.000–12.018	—
Rocker arm shaft O.D.		IN. & EX.	11.973–11.984	—
Cylinder head distortion			—	0.20

CYLINDER + PISTON + PISTON RING

Unit: mm

ITEM	STANDARD		LIMIT	
Compression pressure	1 100–1 500 kPa (11–15 kg/cm ²)		900 kPa (9 kg/cm ²)	
Compression pressure difference	—		200 kPa (2 kg/cm ²)	
Piston to cylinder clearance	0.050–0.060		0.120	
Cylinder bore	74.000–74.015		74.080	
Piston diam.	73.945–73.960 Measure at 15 mm from the skirt end.		73.880	
Cylinder distortion	—		0.20	
Piston ring free end gap	1st	N	Approx. 10.0	8.0
	2nd	N	Approx. 11.0	8.8
Piston ring end gap	1st		0.10–0.25	0.70
	2nd		0.10–0.25	0.70
Piston ring to groove clearance	1st		—	0.180
	2nd		—	0.150
Piston ring groove width	1st		1.01–1.03	—
	2nd		1.21–1.23	—
	Oil		2.01–2.03	—
Piston ring thickness	1st		0.975–0.990	—
	2nd		1.170–1.190	—
Piston pin bore	20.000–20.006		20.030	
Piston pin O.D.	19.996–20.000		19.980	

CONROD + CRANKSHAFT

Unit: mm

ITEM	STANDARD	LIMIT
Conrod small end I.D	20.006–20.014	20.040
Conrod deflection	—	3.0
Conrod big end side clearance	0.10–0.65	1.0
Crankshaft runout	—	0.10

OIL PUMP

ITEM	STANDARD	LIMIT
Oil pump reduction ratio	1.727 (89/50 x 33/34)	—
Oil pressure (at 60°C, 140°F)	Above 40 kPa (0.20 kg/cm ²) Below 20 kPa (0.40 kg/cm ²) at 3 000 r/min.	—

CLUTCH

Unit: mm

ITEM	STANDARD	LIMIT
Clutch cable play	2–3	—
Drive plate thickness	2.9–3.1	2.6
Drive plate claw width	15.6–15.8	14.8
Driven plate distortion	—	0.10
Clutch spring free length	—	38.5

TRANSMISSION + DRIVE CHAIN

Unit: mm Except ratio

ITEM		STANDARD	LIMIT
Primary reduction ratio		1.780 (89/50)	—
Final reduction ratio	E-24	2.866 (43/15)	—
	The others	2.800 (42/15)	—
Gear ratios	Low	2.500 (35/14)	—
	2nd	1.777 (32/18)	—
	3rd	1.380 (29/21)	—
	4th	1.125 (27/24)	—
	Top	0.961 (25/26)	—
Shift fork to groove clearance		0.40–0.60	0.80
Shift fork groove width		5.45–5.55	—
Shift fork thickness		4.95–5.05	—
Countershaft length (Low to 2nd)		111.5 \pm $\begin{smallmatrix} 0 \\ 0.1 \end{smallmatrix}$	—
Drive chain	Type	D.I.D.: 630YL TAKASAGO: RK630GSV	—
	Links	102	—
	20-pitch length	—	383.2
Drive chain slack		15–25	—

CARBURETOR

ITEM	SPECIFICATION	
	E-01,06,24,28	The others
Carburetor type	MIKUNI BS36SS	←
Bore size (venturi)	32 mm	←
I.D. No.	00A30	00A00
Idle r/min.	1 100 \pm 50 r/min.	←
Fuel level	3.0 \pm 0.5 mm	←
Float height	21.4 \pm 1.0 mm	←
Main jet (M.J.)	#120 (Nos. 1 & 4); #122.5 (Nos. 2 & 3)	#120
Main air jet (M.A.J.)	1.2 mm	←
Jet needle (J.N.)	5D59-2nd	←
Needle jet (N.J.)	X-5	←
Throttle valve (Th. V.)	# 130	←
Pilot jet (P.J.)	# 47.5	←
By pass (B.P.)	0.9, 0.8, 0.9 mm	←
Pilot outlet (P.O.)	0.9 mm	←
Air screw (A.S.)	PRE-SET (2 turns back)	←
Valve seat (V.S.)	2.0 mm	←

ITEM	SPECIFICATION	
	E-01,06,24,28	The others
Starter jet (G.S.)	# 32.5	←
Pilot air jet (P.A.J.)	# 125	←
Throttle cable play	2–3 mm	←
Choke cable play	0.5–1.0 mm	←

ELECTRICAL

Unit: mm

ITEM	SPECIFICATION		NOTE
Ignition timing	10° B.T.D.C. Below 1 500 ± 100 r/min and 32° B.T.D.C. Above 3 500 ± 100 r/min.		
Firing order	1.2.4.3		
Spark plug	Type	NGK: X27ES-U N.D.: D9EA	E-01,24,25, 27,34
	Gap	0.6–0.7	
	Type	NGK: X27ESR-U N.D.: DR8ES	The others
	Gap	0.6–0.7	
Spark performance	Over 8 at 1 atm.		
Signal coil resistance	100–300 Ω		Y-BI, Lg-B
Ignition coil resistance	Primary	2–5 Ω	O/W-W, O/W-B/Y
	Secondary	30–40 k Ω	Plug cap-Plug cap
Generator no-load voltage	More than 80 V (AC) at 5 000 r/min.		
Generator coil resistance	0.1–1.0 Ω		
Regulated voltage	14.0–15.5 V at 5 000 r/min.		
Starter motor brush length	Limit: 9		N.D.
Commutator under cut	Limit: 0.2		
Starter relay resistance	3–7 Ω		
Battery	Type designation	SYBI4L-B2	
	Capacity	12V50.4kC(14Ah)/10HR	
	Standard electrolyte S.G.	1.28 at 20°C (68°F)	
Fuse size	HEAD	10 A	
	SIGNAL	10 A	
	IGNITION	10 A	
	MAIN	15 A	
	POWER SOURCE	10 A	

WATTAGE

Unit: W

ITEM		SPECIFICATION			
		E-01,24,27	E-06,28	E-02,04,15,17 21,25,34,39	E16,18,22,26
Headlight	HI	60	←	←	←
	LO	55	←	←	←
Parking or city light				4	←
Tail/Brake light		8/23	←	5/21	←
Turn signal/position light		23	23/8	21	←
Speedometer light		3.4	←	←	←
Tachometer light		3.4	←	←	←
Fuel and oil temp. meter light		3.4	←	←	←
Turn signal indicator light		3.4	←	←	←
High beam indicator light		1.7	←	←	←
Neutral indicator light		3.4	←	←	←
Oil pressure indicator light		3.4	←	←	←
Side stand check light		3.4	←	←	
License light		8	←	5	←

BRAKE + WHEEL

Unit: mm

ITEM	STANDARD		LIMIT
Rear brake pedal height	40		—
Brake disc thickness	Front	5.0 ± 0.2	4.5
	Rear	6.7 ± 0.2	6.0
Brake disc runout	—		0.30
Master cylinder bore	Front	15.870 – 15.913	—
	Rear	15.870 – 15.913	—
Master cylinder piston diam.	Front	15.827 – 15.854	—
	Rear	15.827 – 15.854	—
Brake caliper cylinder bore	Front	38.180 – 38.256	—
	Rear	38.180 – 38.256	—
Brake caliper piston diam.	Front	38.098 – 38.148	—
	Rear	38.098 – 38.148	—
Wheel rim runout	Axial	—	2.0
	Radial	—	2.0
Wheel axle runout	Front	—	0.25
	Rear	—	0.25
Tire size	Front	110/90 V 16	—
	Rear	130/90 V 17	—
Tire tread depth	Front	—	1.6
	Rear	—	2.0

SUSPENSION

Unit: mm

ITEM	STANDARD	LIMIT	NOTE
Front fork stroke	150	—	
Front fork spring free length	—	504	
	—	500	Only for E-28
Front fork oil level	210	—	
	180	—	Only for E-28
Front fork air pressure	30 kPa, (0.3 kg/cm ²)	—	Only for E-28
Rear wheel travel	115	—	
Swing arm pivot shaft runout	—	0.3	

TIRE PRESSURE

COLD INFLATION TIRE PRESSURE	SOLO RIDING		DUAL RIDING	
	kPa	kg/cm ²	kPa	kg/cm ²
FRONT	250	2.50	250	2.50
REAR	250	2.50	290	2.90

FUEL + OIL

ITEM	SPECIFICATION	NOTE
Fuel type	Gasoline used should be graded 85-95 octane or higher. An unleaded or low-lead gasoline type is recommended.	
Fuel tank including reserve	20.0 L	
reserve	4.9 L	
Engine oil type	SAE 10W/40, API SE or SF	
Engine oil capacity	Change	3 200 ml
	Filter change	3 600 ml
	Overhaul	4 000 ml
Front fork oil type	Fork oil # 15	
Front fork oil capacity (each leg)	268 ml	
	286 ml	Only for E-28
Brake fluid type	DOT3, DOT4 or SAE J1703	

GSX1100ES/EF (GS1150EF)

This section gives only servicing procedures and service data which differ from those of the GSX1100E (GS1150E) Model and describes the new features of GSX1100ES/EF (GS1150EF). Refer to the sections 1 through 7 except for the items described in this section.

NOTE:

How the section is compiled.

Any differences in service specifications and service data with those that apply to the GSX1100ES/EF (GS1150EF) Models are clearly indicated with an asterisk ().*

CONTENTS

VIEW OF SUZUKI GSX1100ES	8- 1
GSX1100EF	8- 2
SPECIFICATIONS	8- 3
COWLING	8- 5
SUSPENSION SETTING	8- 9
WIRE AND CABLE ROUTING	8-10
SERVICE DATA	8-12

VIEW OF SUZUKI GSX1100ES

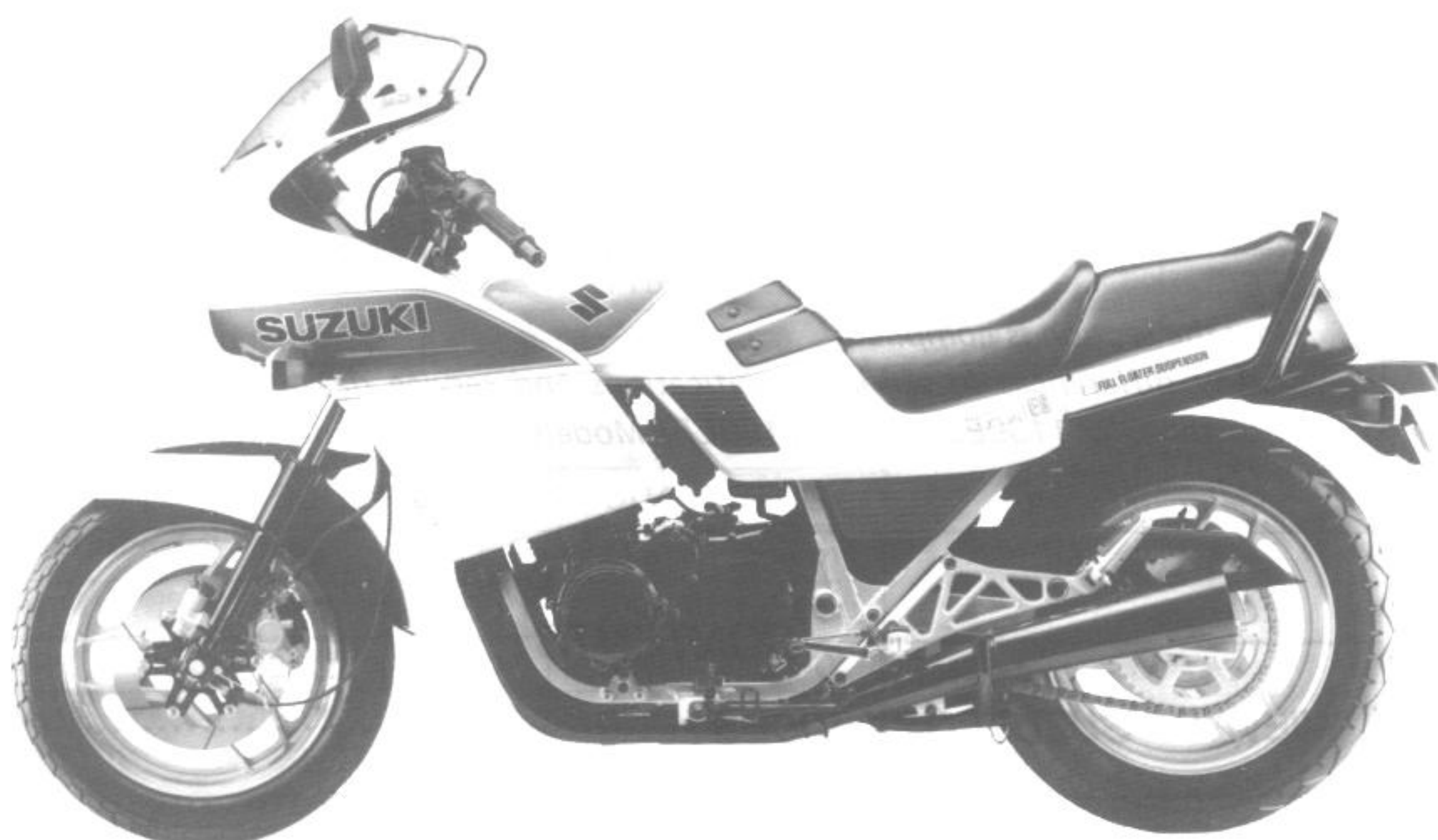

Left side



Right side

VIEW OF SUZUKI GSX1100EF

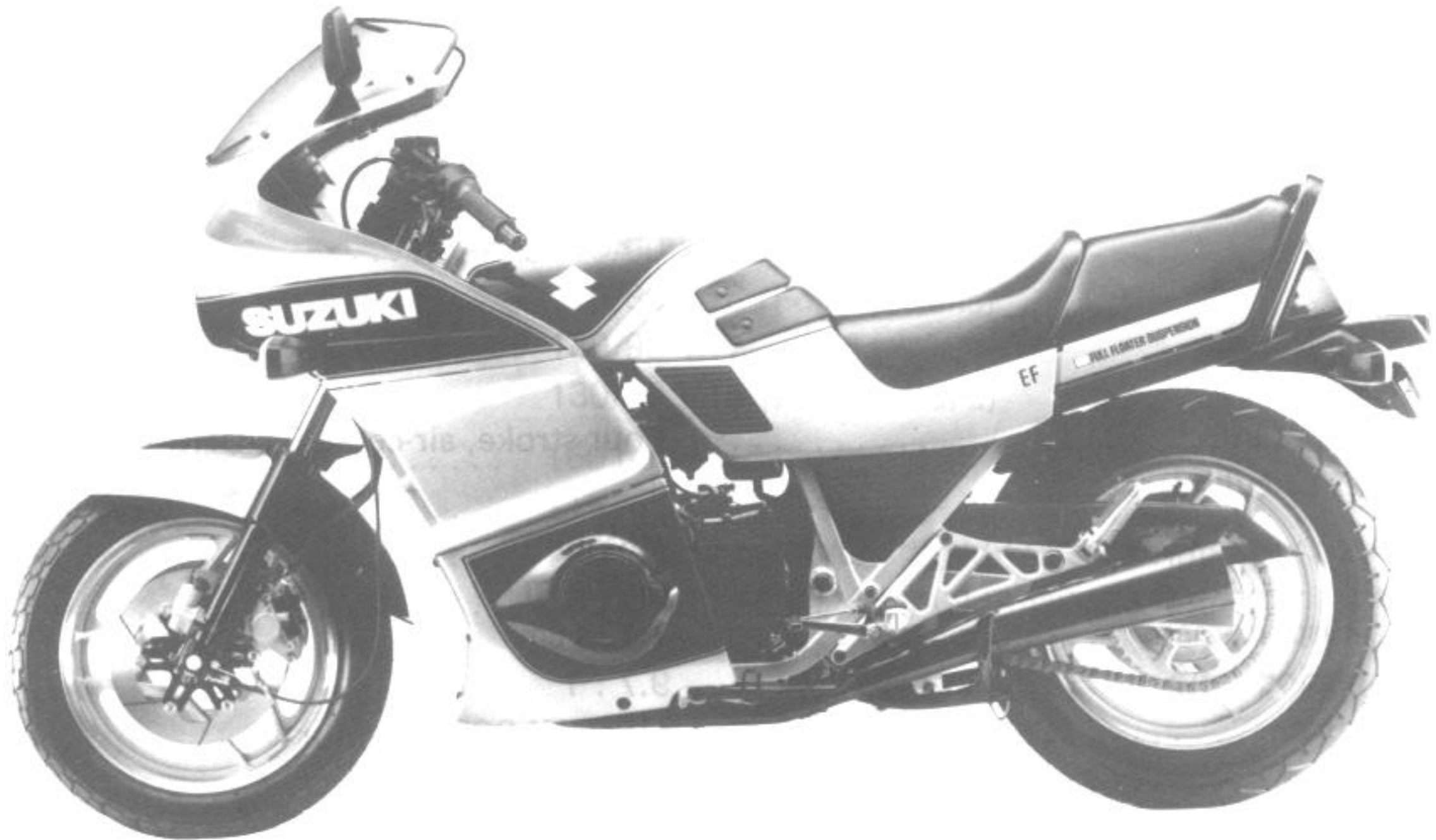

Left side



Right side

SPECIFICATIONS

DIMENSIONS AND DRY MASS

Overall length	2 240 mm
Overall width	*730 mm
Overall height	*1 280 mm
Wheelbase	1 550 mm
Ground clearance	155 mm
Seat height	785 mm
Dry mass	*237 kg . . . ES *238 kg . . . EF

ENGINE

Type	Four-stroke, air-cooled, DOHC
Number of cylinders	4
Bore	74.0 mm
Stroke	66.0 mm
Piston displacement	1 135 cm ³
Compression ratio	9.7 : 1
Carburetor	MIKUNI BS36SS, four
Air cleaner	Paper element
Starter system	Electric
Lubrication system	Wet sump

TRANSMISSION

Clutch	Wet multi-plate type
Transmission	5-speed constant mesh
Gearshift pattern	1-down, 4-up
Primary reduction	1.780 (89/50)
Final reduction	2.800 (42/15) 2.866 (43/15) (For Australia)
Gear ratios, Low	2.500 (35/14)
2nd	1.777 (32/18)
3rd	1.380 (29/21)
4th	1.125 (27/24)
Top	0.961 (25/26)
Drive chain	DAIDO D.I.D. 630YL or TAKASAGO RK630GSV, 102 links

CHASSIS

Front suspension	Posi Dump Fork system, telescopic, coil spring 4-way adjustable, damper 4-way adjustable. Posi Dump Fork system, telescopic, pneumatic/coil spring 4-way adjustable, dumper 4-way adjustable . . . For Canada
----------------------------	---

Specifications marked with asterisks (*) are exclusive to GSX1100ES/EF (GS1150EF).

Rear suspension	Full-floating suspension system, spring pre-load adjustable, damper 4-way adjustable
Steering angle	*32° (right and left)
Caster	62°00'
Trail	117 mm
Turning radius	*3.3 m
Front brake	Disc brake, twin
Rear brake	Disc brake
Front tire size	110/90 V16
Rear tire size	120/80 V16 (For Australia) 130/90 V17 130/80 V18 (For Australia)
Front fork stroke	150 mm
Rear wheel travel	115 mm
Front tire pressure	250 kPa (2.50 kg/cm ²) (Normal solo riding)
Rear tire pressure	250 kPa (2.50 kg/cm ²) (Normal solo riding)

ELECTRICAL

Ignition type	Transistorized
Ignition timing	10° B.T.D.C. below 1 500 r/min and 32° B.T.D.C. above 3 500 r/min
Spark plug	NGK D9EA or NIPPON DENSO X27ES-U (E-01, 24, 25, 27, 34) NGK DR8ES or NIPPON DENSO X27ESR-U (The Others)
Battery	12V 50.4 kC (14 Ah)/10 HR
Generator	Three-phase A.C. generator
Fuse	10/10/10/10/15A

CAPACITIES

Fuel tank including reserve	20.0 L
reserve	4.9 L
Engine oil	3 200 ml
Front fork oil	*280 ml 286 ml (For Canada)

Specifications are subject to change without notice.

Specifications marked with asterisks (*) are exclusive to GSX1100ES/EF.

COWLING

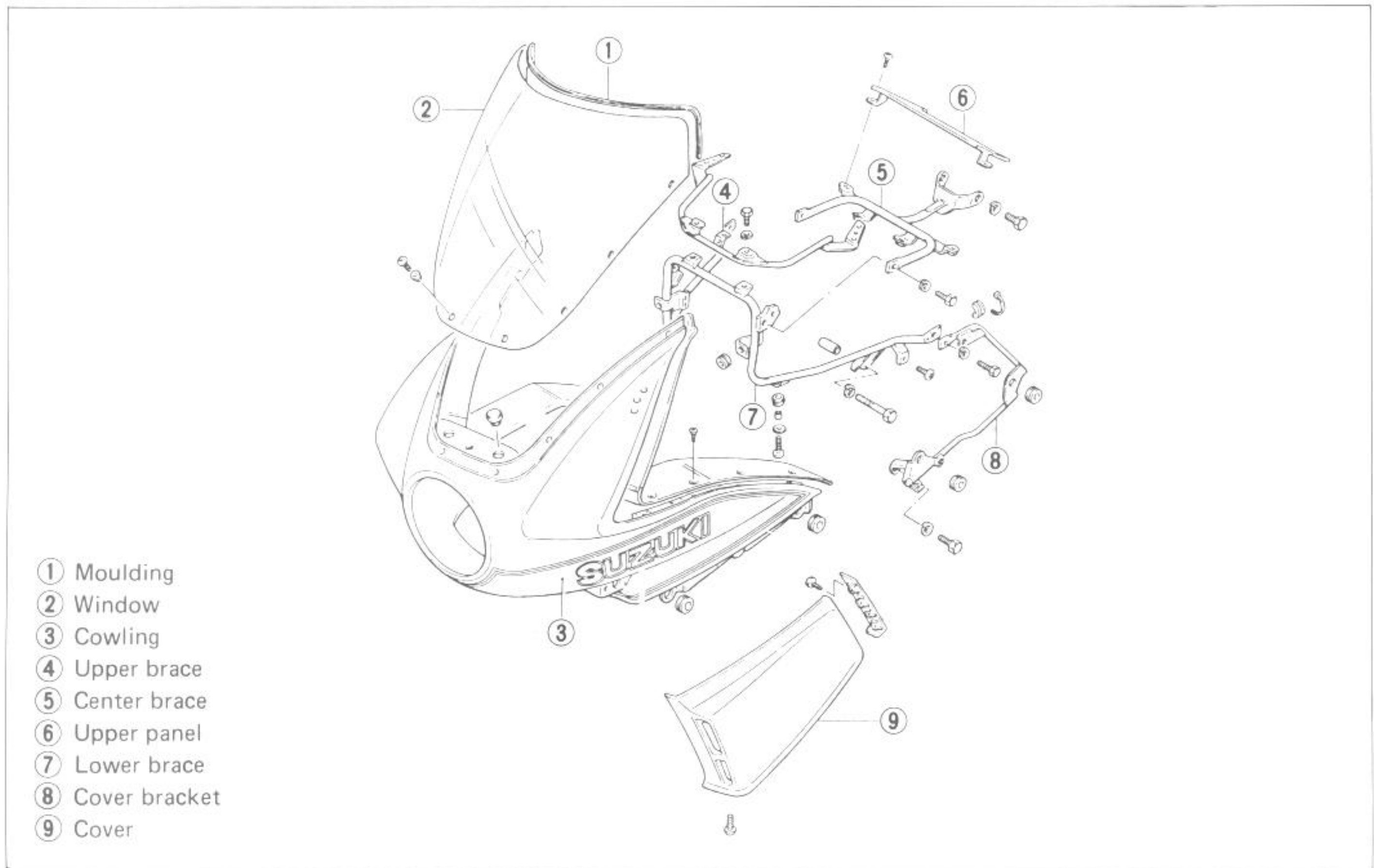

ES MODEL

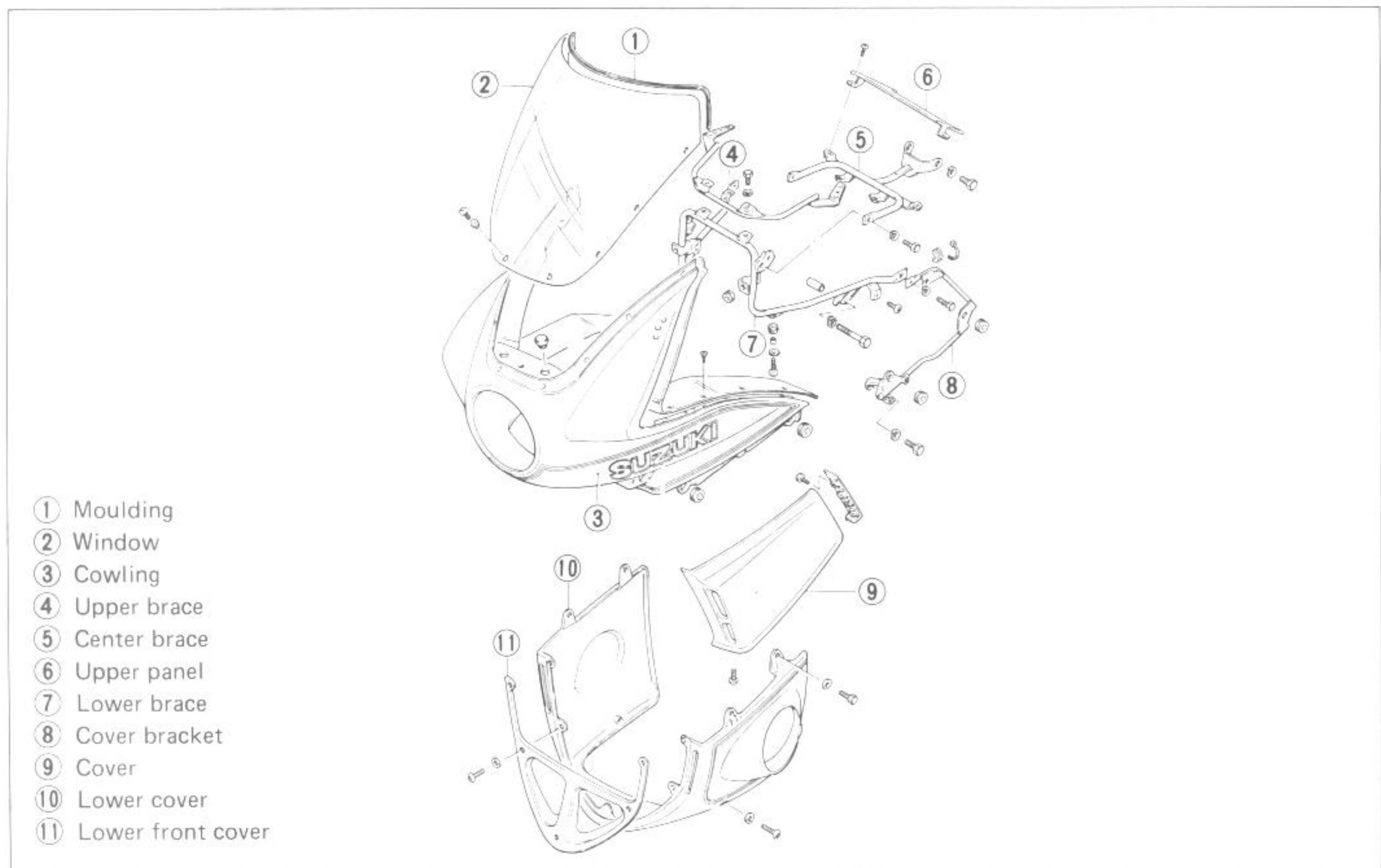

EF MODEL

REMOVAL

- Remove the seat and fuel tank.
- Take off the cowling side cover, right and left.

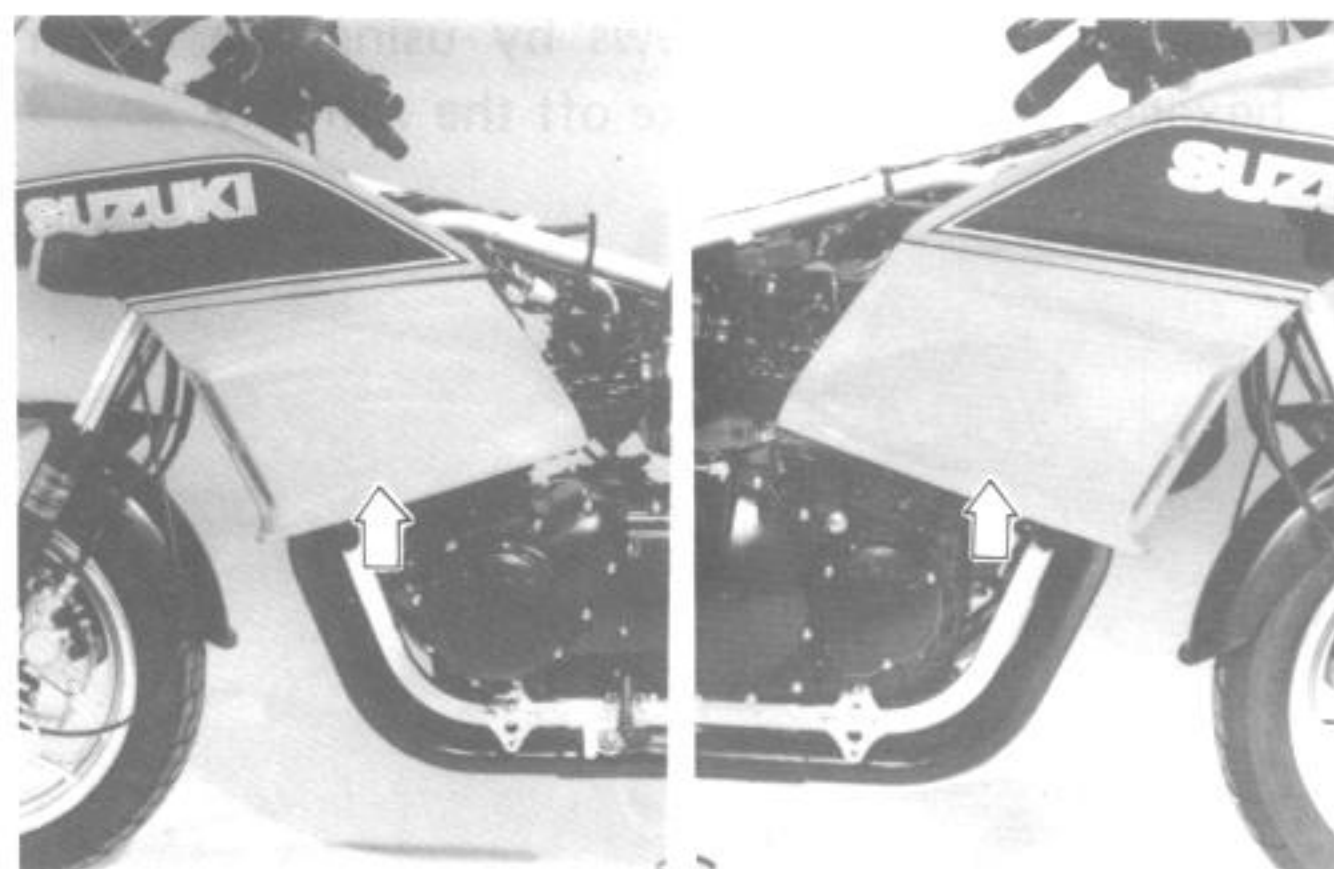

For ES

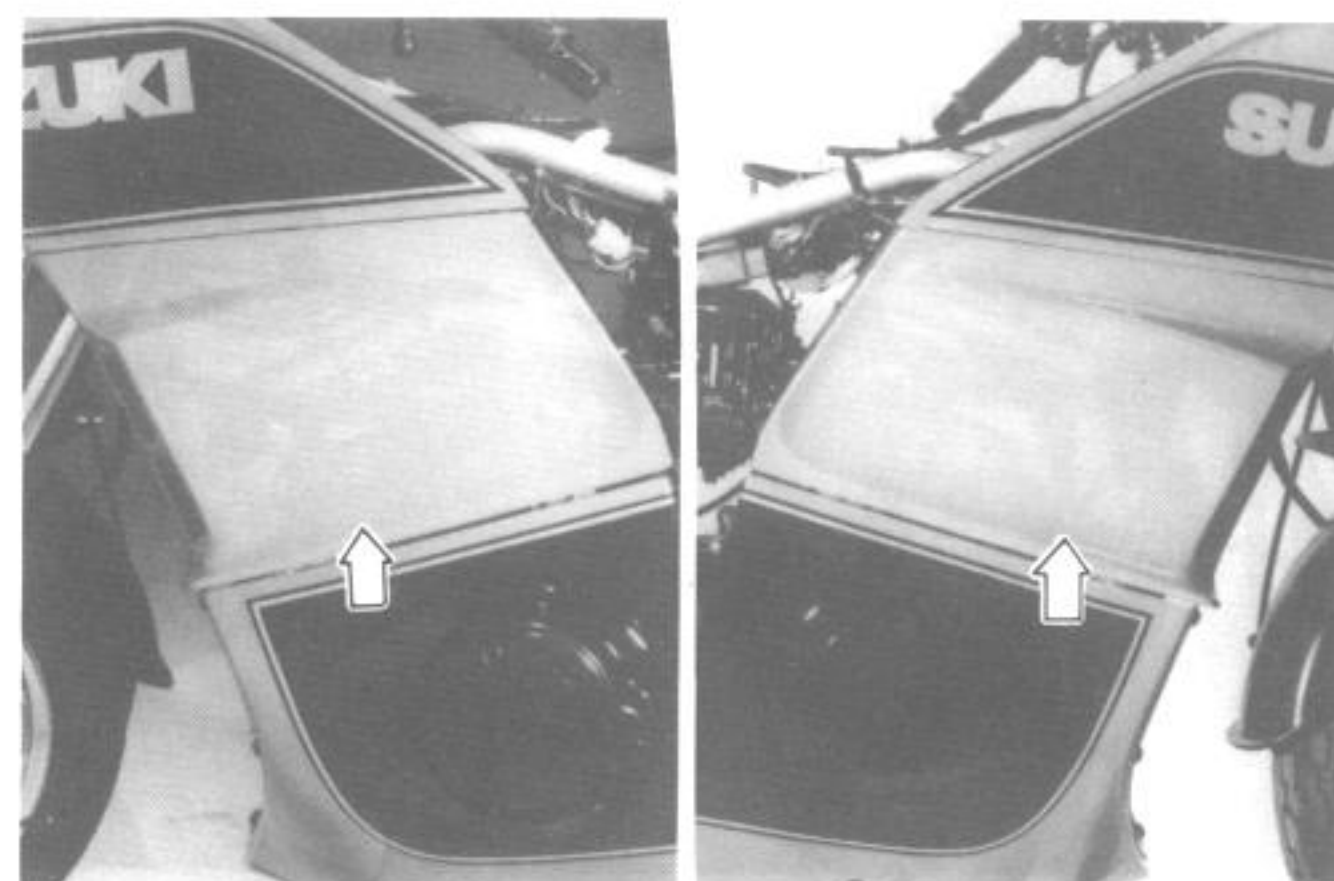

For EF

- Remove the two screws and four bolts and take off the cowling lower cover. (For EF)

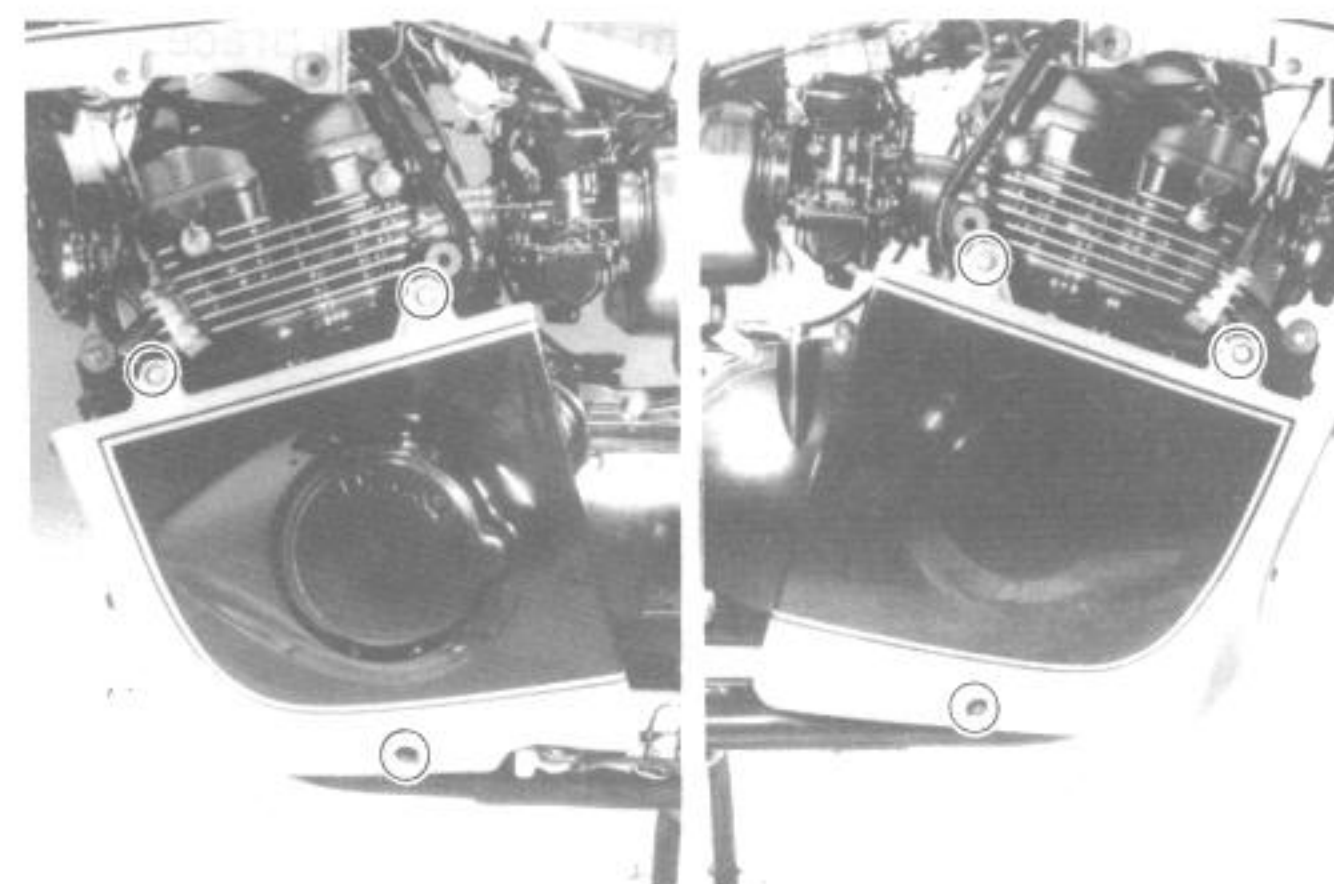

- Disconnect the front turn signal light couplers and remove the front turn signal lights, right and left.



- Remove the eight screws by using the 3-mm hexagon wrench and take off the window.

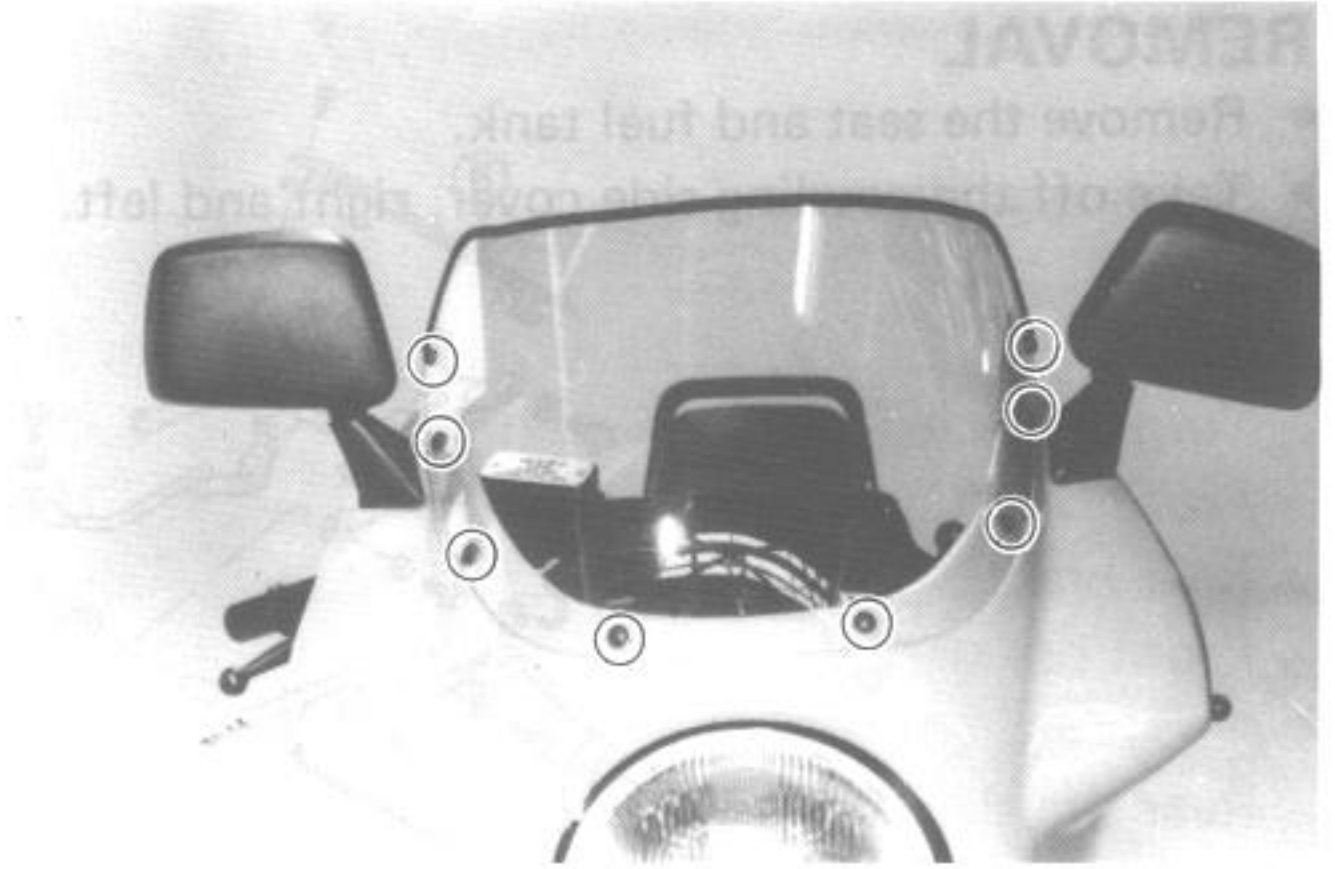

- Remove the two bolts and four screws, and take off the cowling forward.

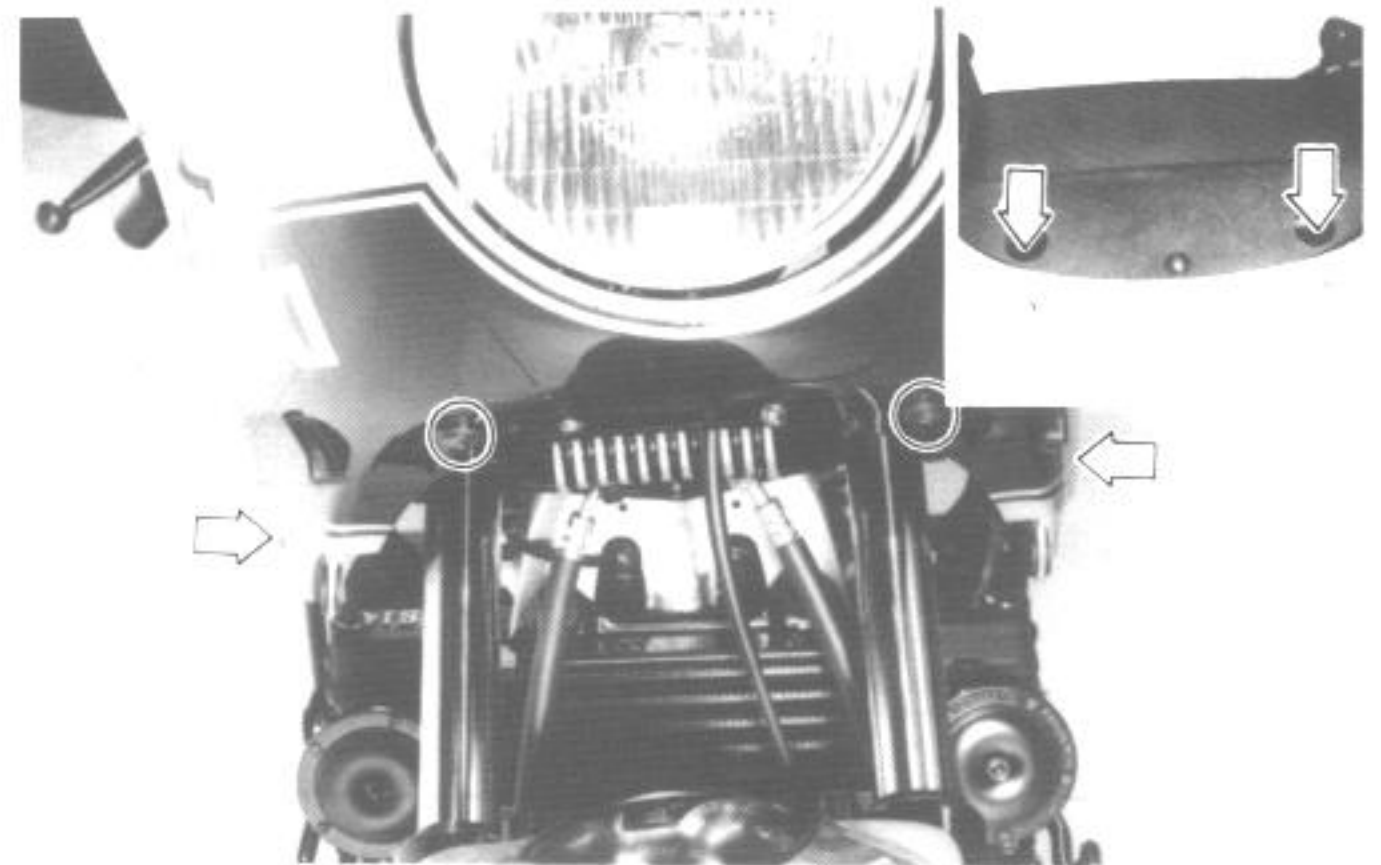

- Take off the clamps from the cowling brace.

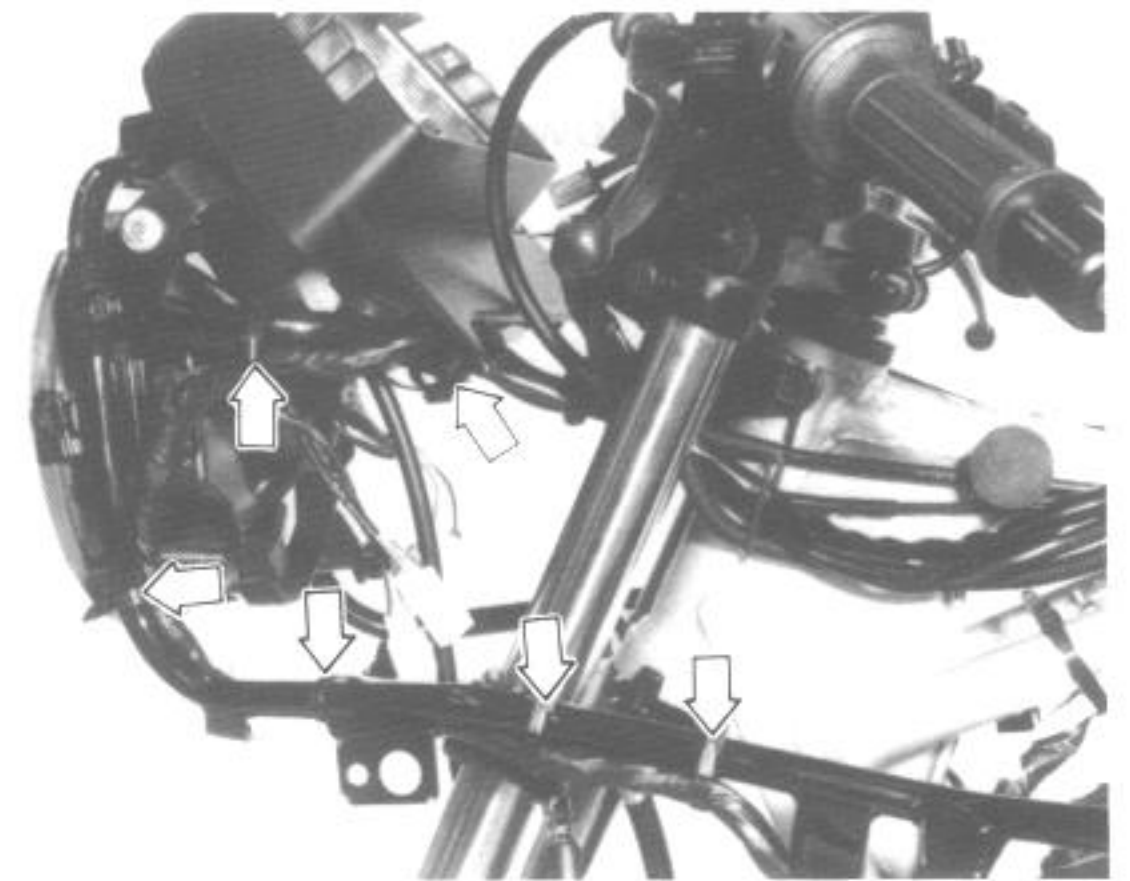

- Disconnect the headlight and meter couplers, and speedometer cable.

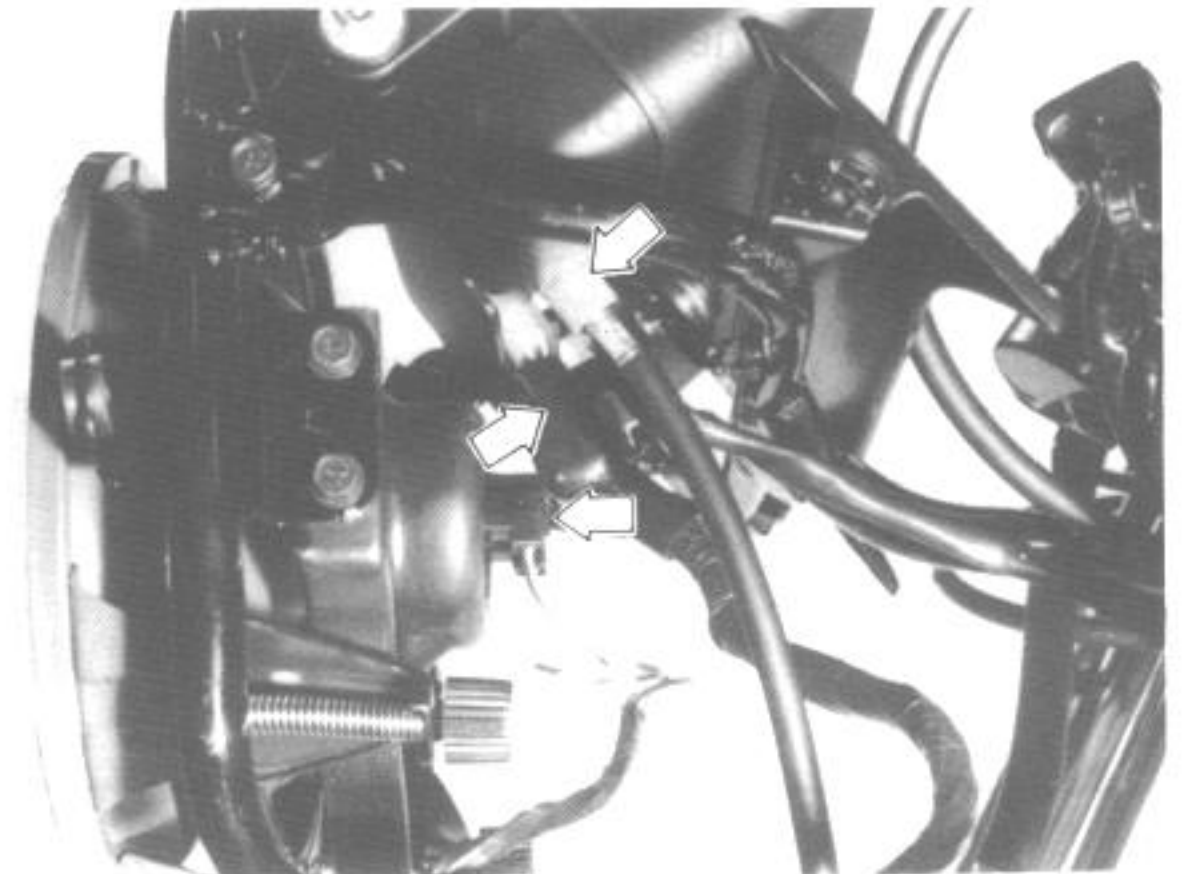

- Disconnect the gear position indicator light switch coupler and clamp.

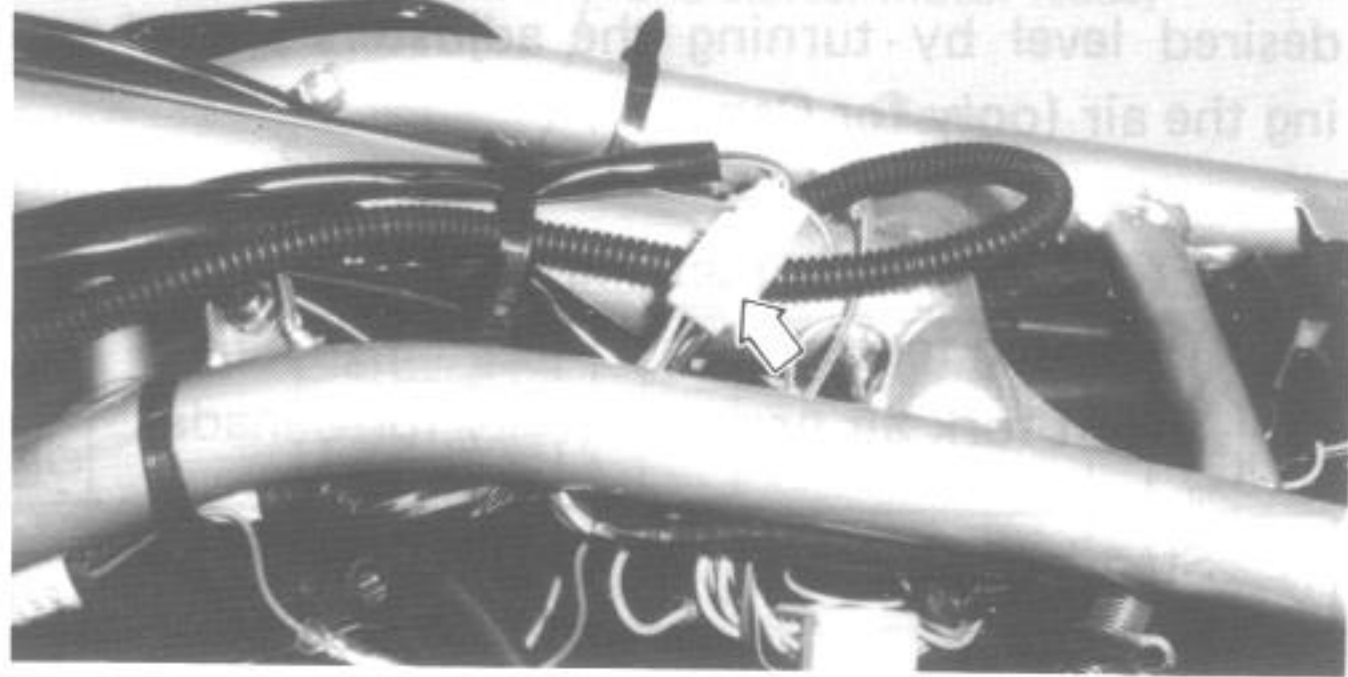

- Remove the bolts and take off the cowling brace with head light and meter forward.

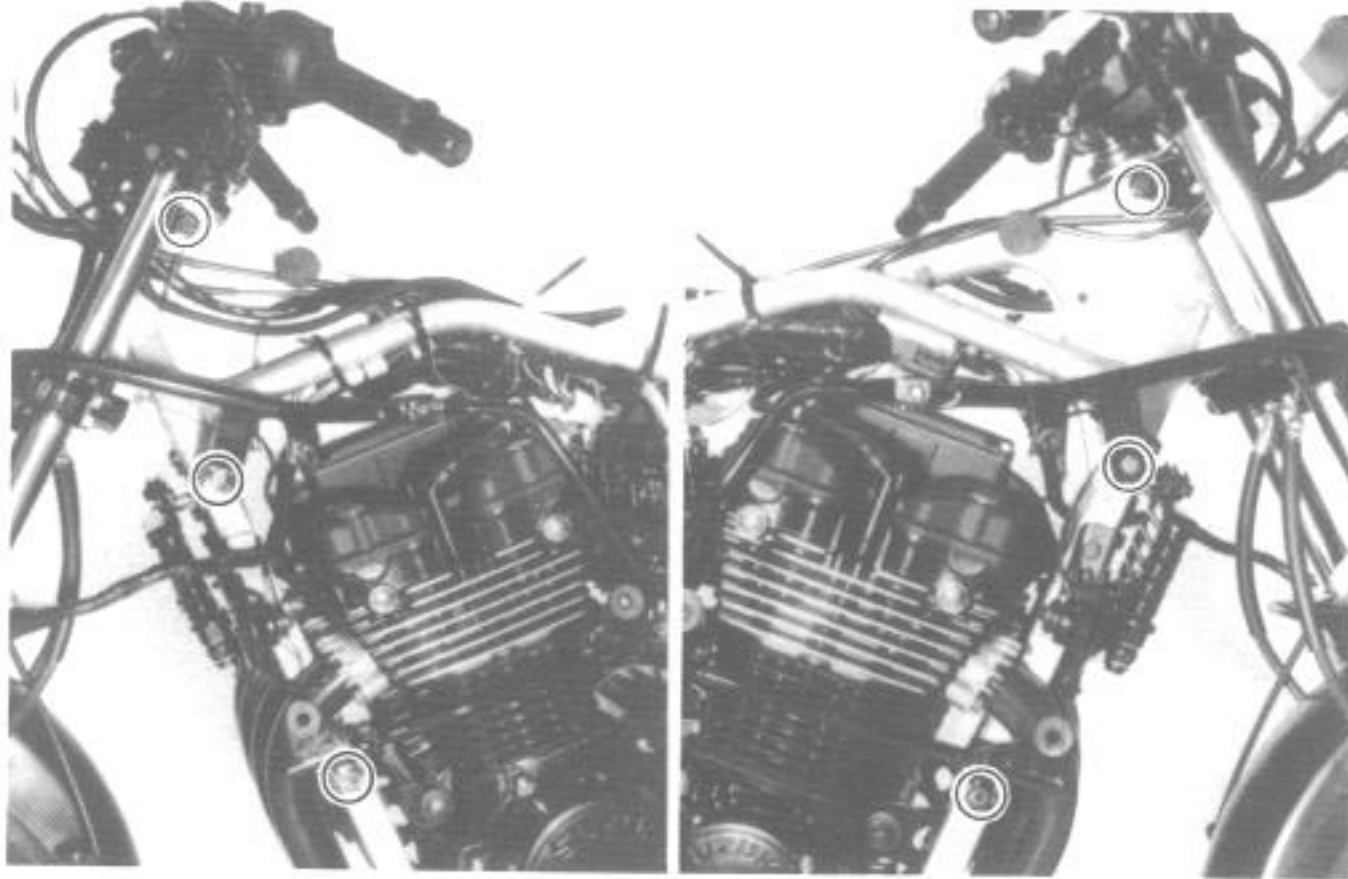

REASSEMBLY

Reassemble and remount the cowling in the reverse order of disassembly and removal.

(See page 8-10).

SUSPENSION SETTING

FRONT FORK

The front suspension of this motorcycle, as indicated in the illustration, can be adjusted to the desired level by turning the adjusters and charging the air (only for Canada).

- ① Front fork spring setting
- ② Damping force setting
- ③ Front fork air pressure (only for Canada)

Standard air pressure	30 kPa (0.3 kg/cm ²)
-----------------------	-------------------------------------

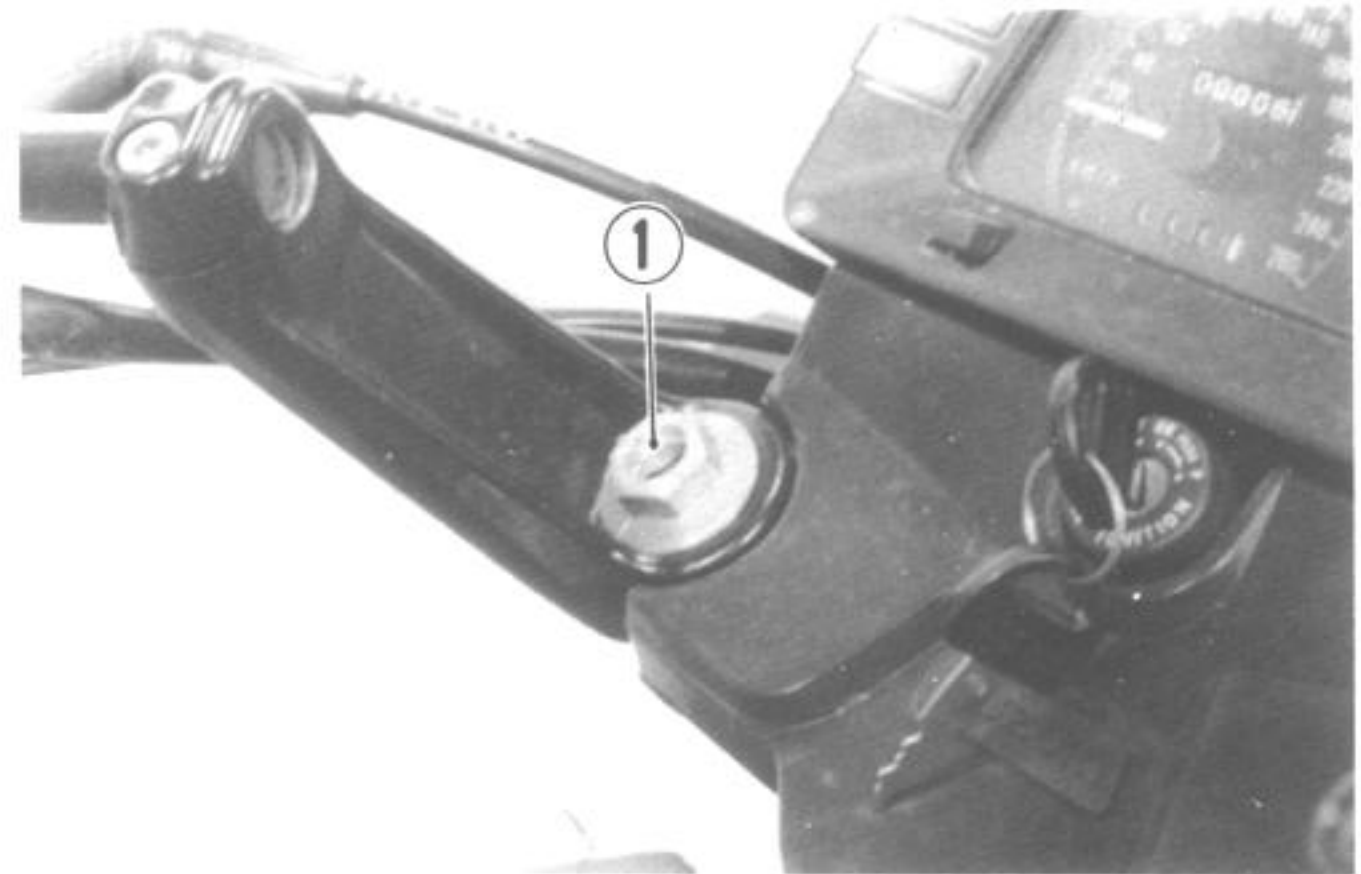

REAR SHOCK ABSORBER

The rear suspension can be adjusted by changing the spring preload and damping force.

- ④ Spring preload setting
- ⑤ Damping force setting

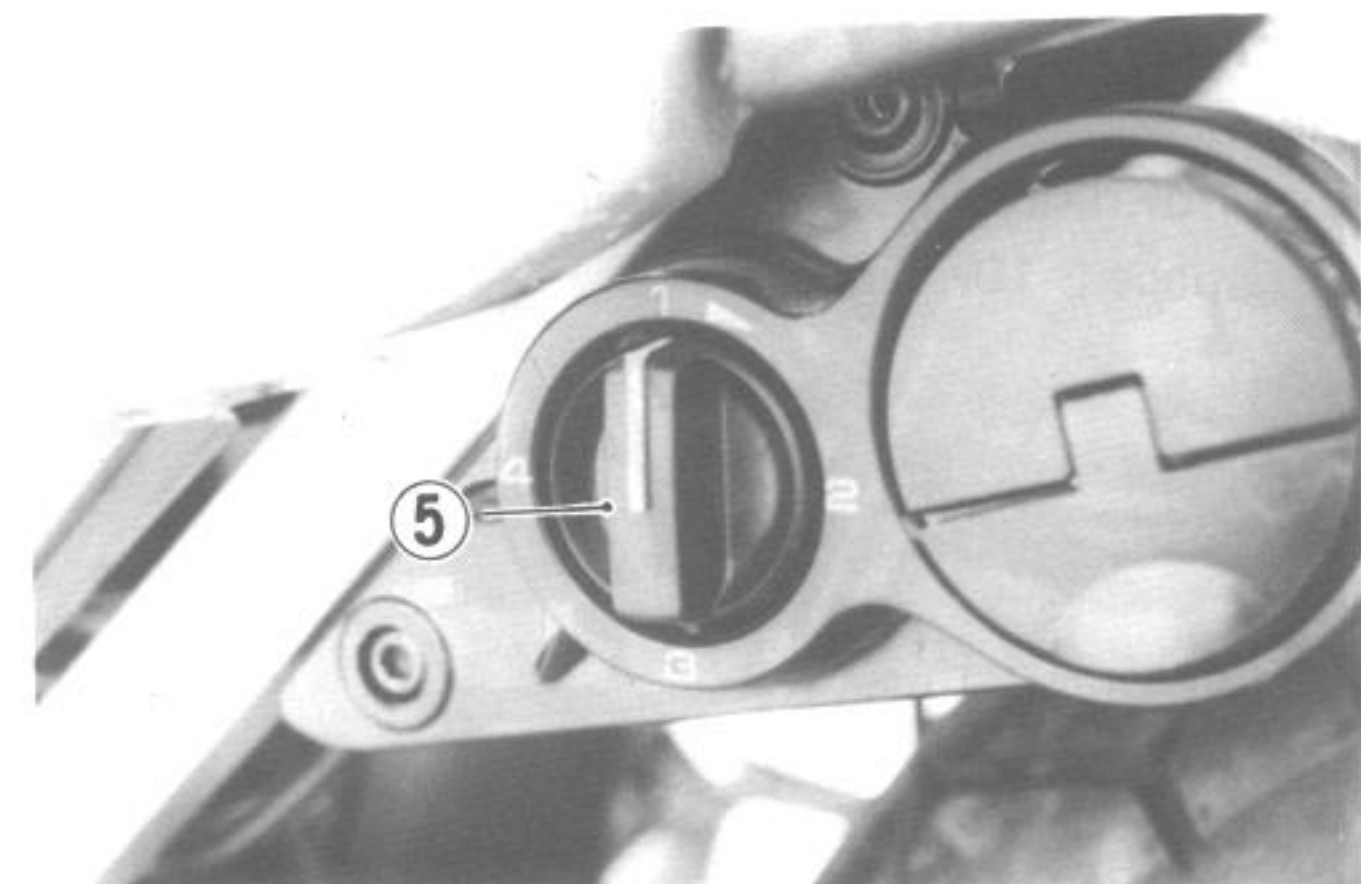
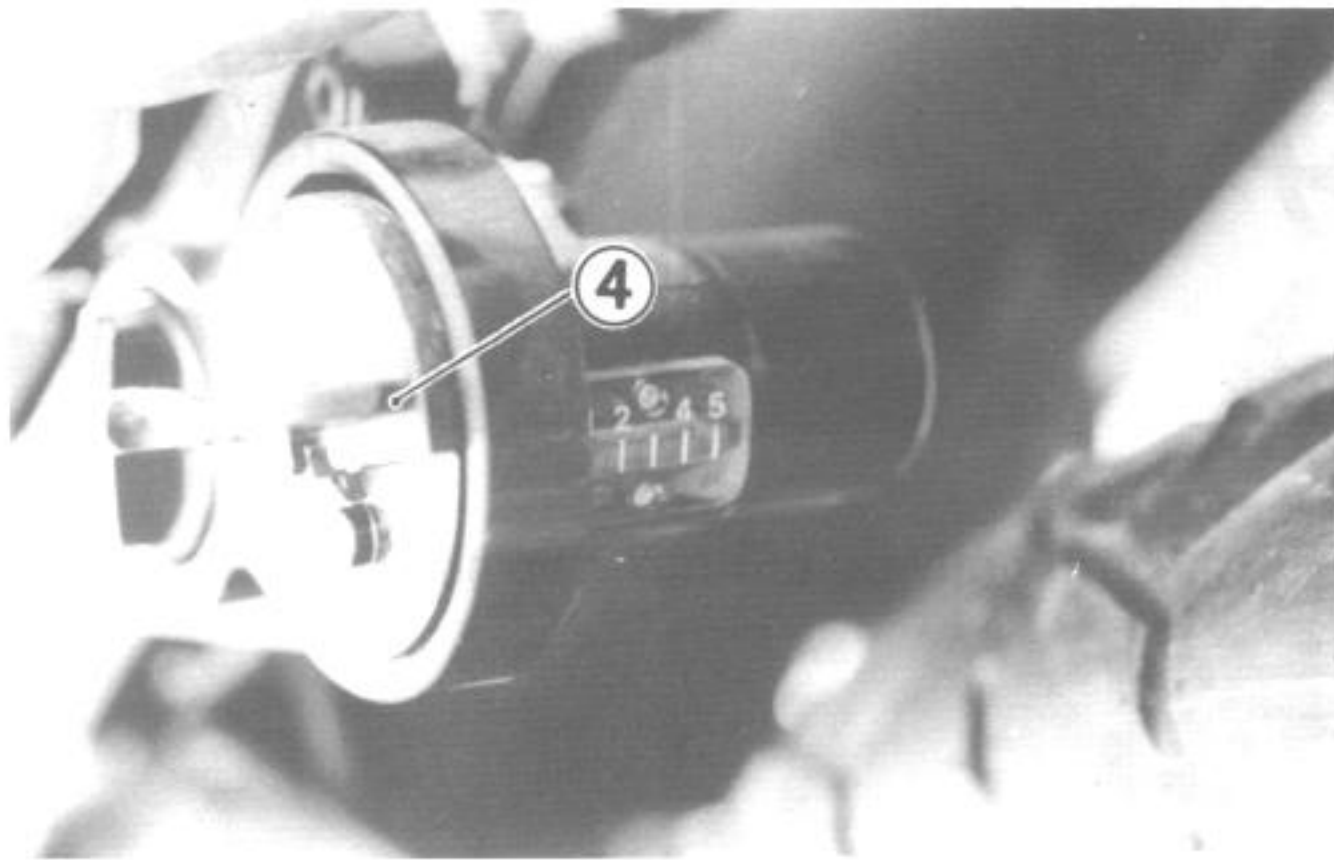
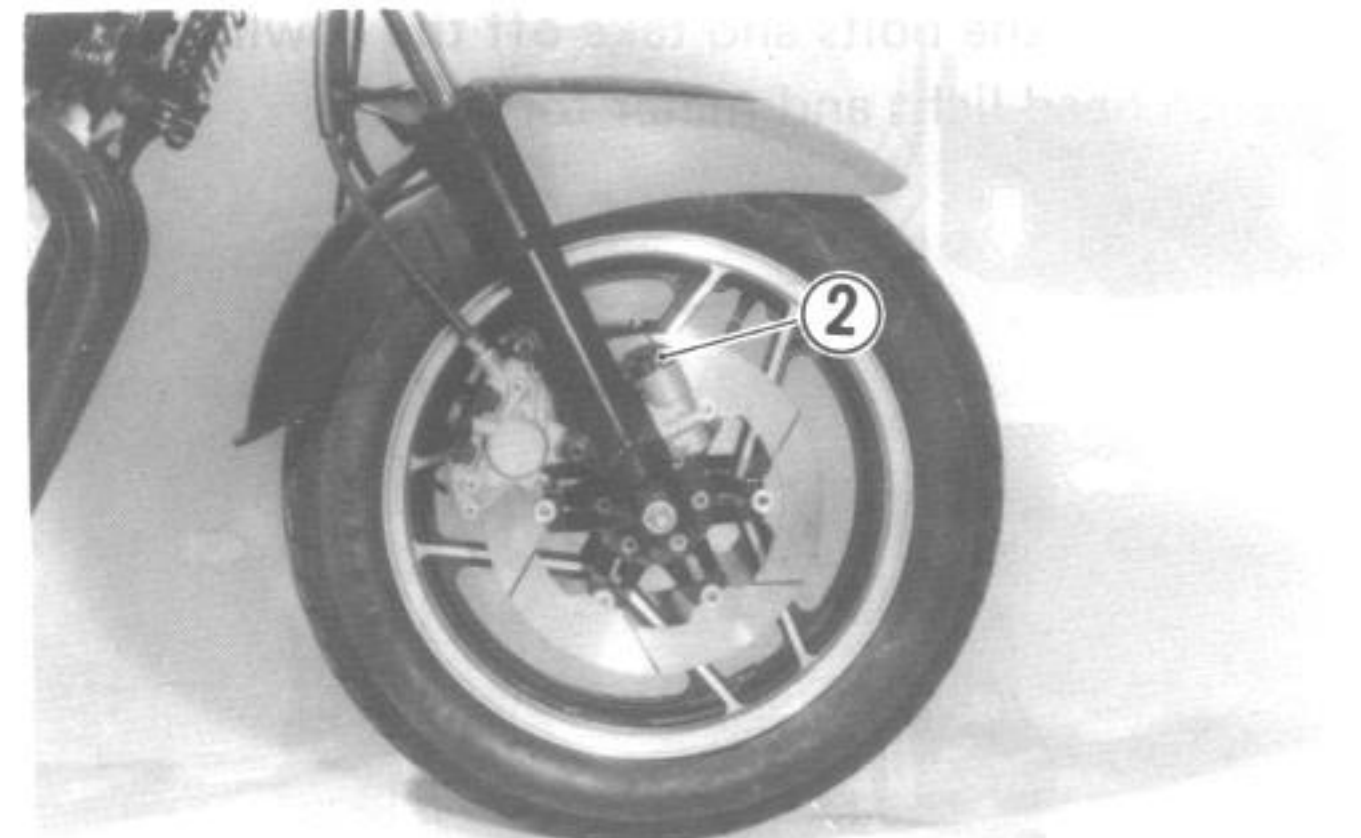

Both front and rear suspensions are adjustable according to the rider's requirements. The high speed capability of this motorcycle make proper suspension setting and balance very important. Use the following table to adjust the front and rear suspensions.

SUSPENSION SETTING TABLE

ITEM	Front fork*		Rear shock absorber		Remarks
	Spring preload	Posi-damp unit setting	Spring preload	Damping force	
Standard	2 (2)	3 (3)	3 (2)	2 (2)	Solo riding
Softer	1 (1)	2 (2)	2 (1)	1 (1)	Solo riding
Stiffer	3 (3)	4 (3)	3 (3)	3 (4)	Solo riding
Dual riding	3 (3)	4 (3)	4 (3)	3 (4)	—

* Standard air pressure of front fork for Canada is 0.3 kg/cm².
 () indicate the specifications for Canada and Australia.

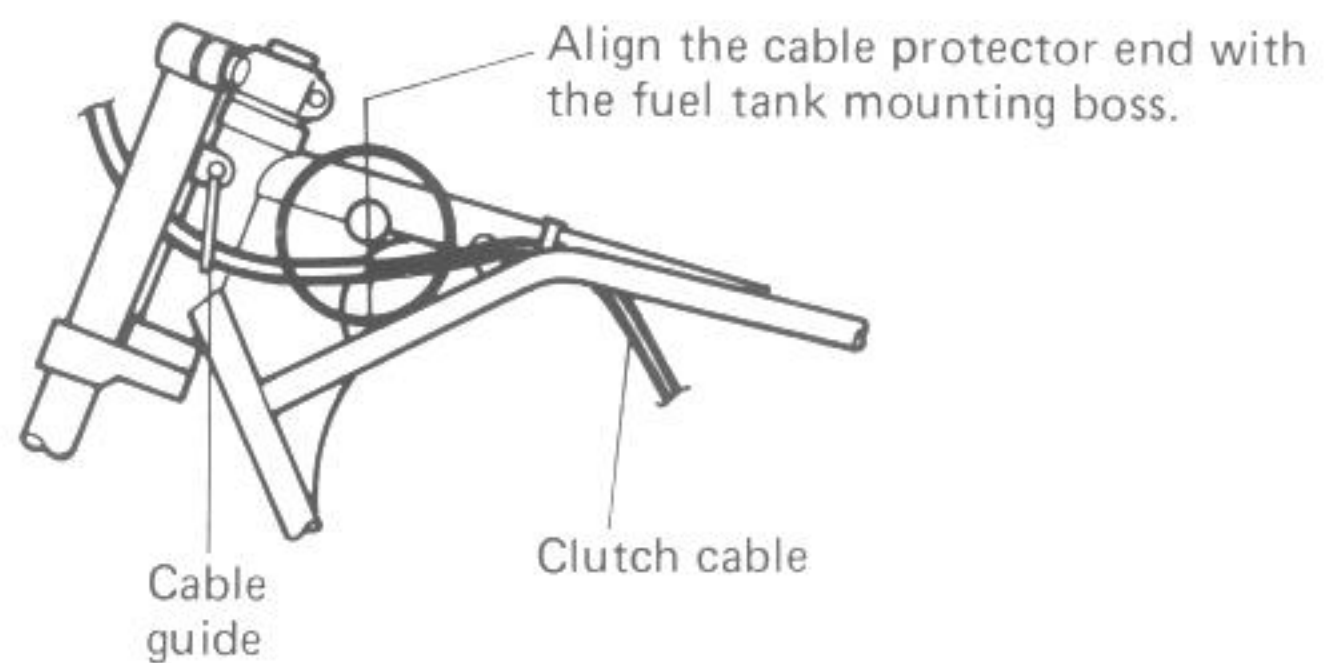
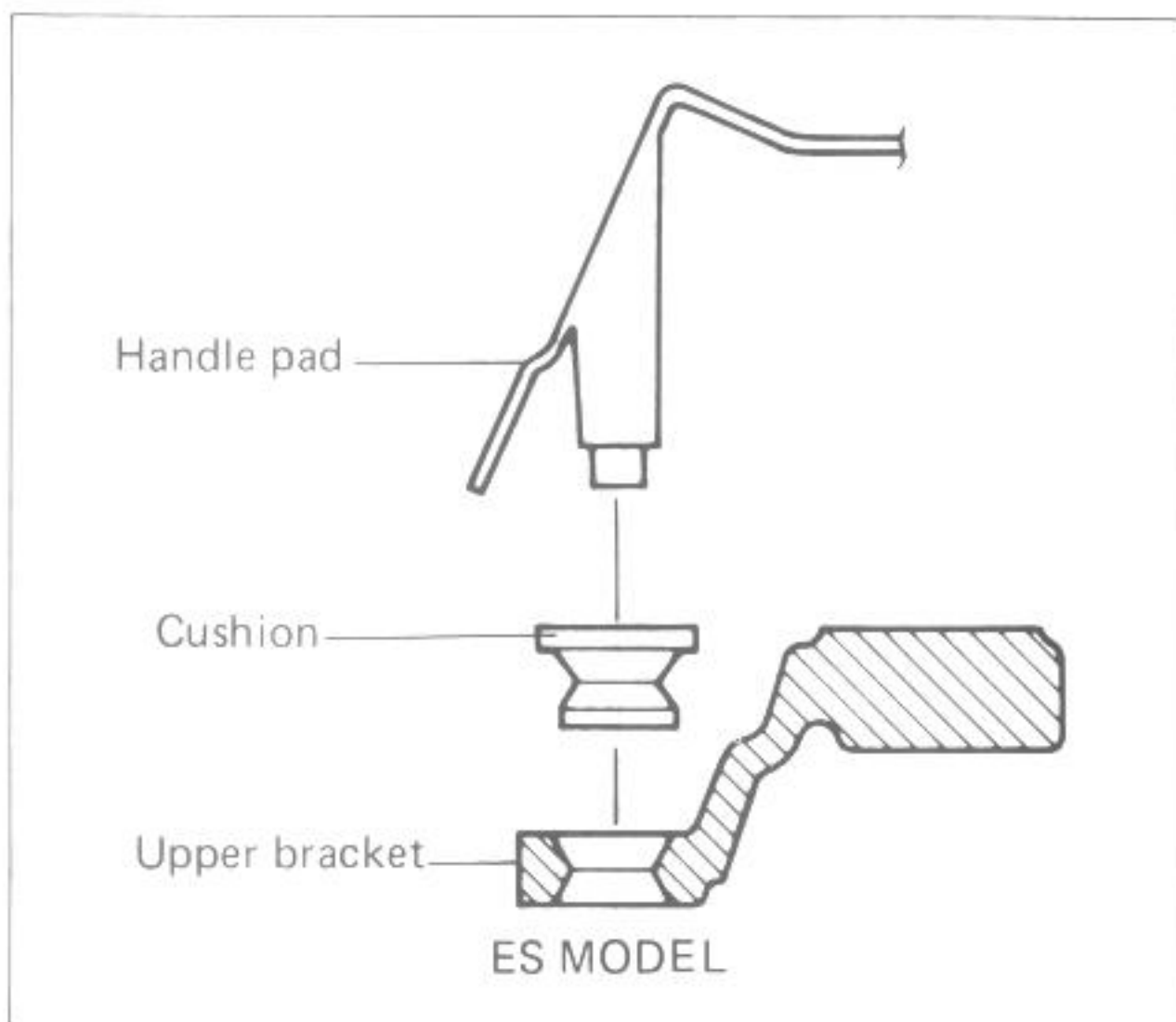
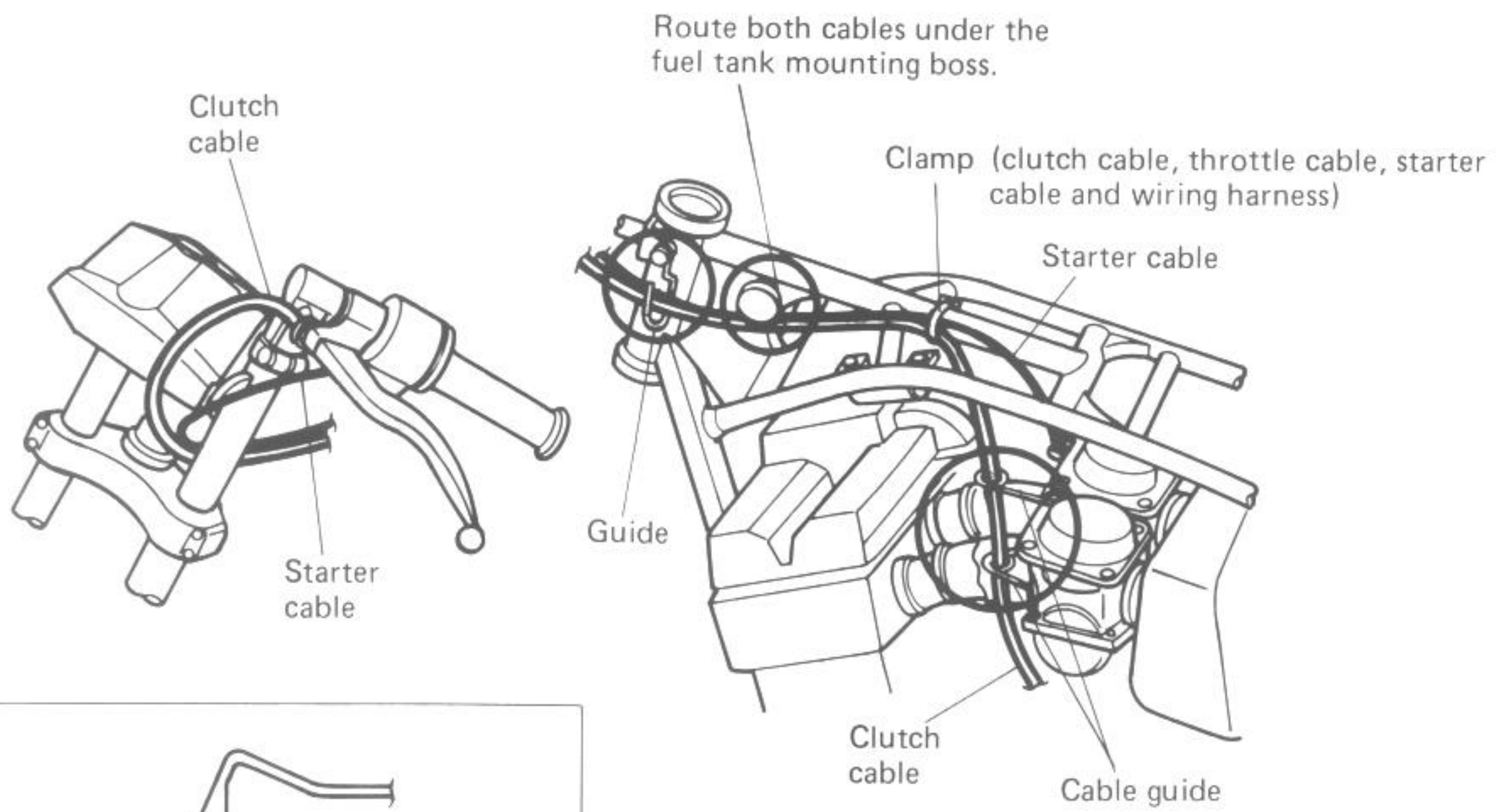
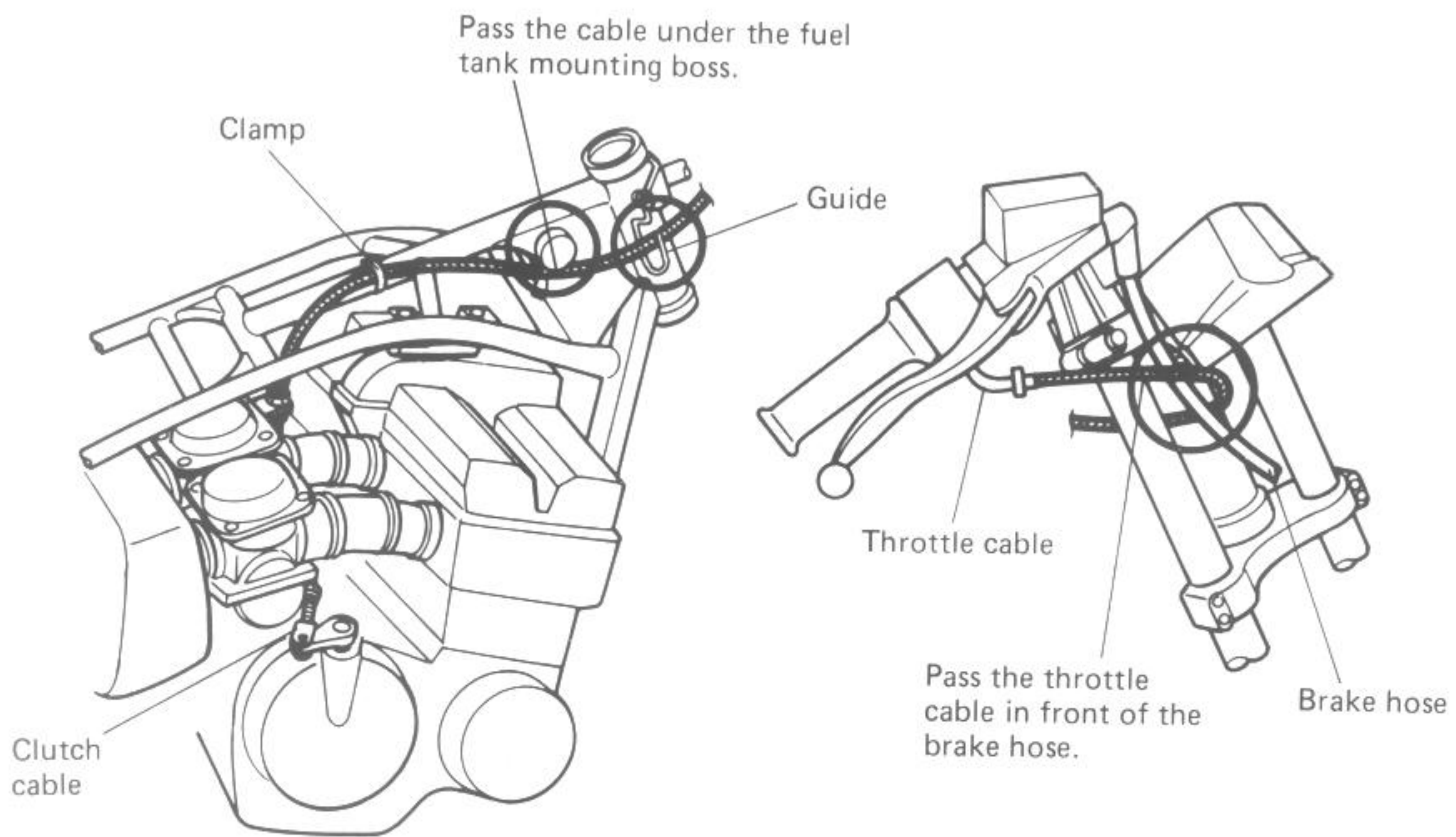

SERVICE DATA**VALVE + GUIDE**

Unit: mm

ITEM		STANDARD		LIMIT
Valve diam.		IN.	28.0	—
		EX.	23.0	—
Valve lift	E-17,18 22,39	IN.	7.0	—
		EX.	6.5	—
	The others	IN.	8.0	—
		EX.	7.5	—
Valve clearance (when cold)		IN. & EX.	0.08–0.13	—
Valve stem deflection		IN.	—	0.35
		EX.	—	0.35
Valve guide I.D.		IN. & EX.	5.500–5.512	—
Valve stem O.D.		IN.	5.470–5.487	—
		EX.	5.445–5.460	—
Valve stem runout		IN. & EX.	—	0.05
Valve head thickness		IN. & EX.	—	0.5
Valve stem end length		IN. & EX.	—	3.8
Valve seat width		IN. & EX.	0.9–1.1	—
Valve head radial runout		IN. & EX.	—	0.03
Valve spring free length (IN. & EX.)		INNER	—	31.9
		OUTER	—	35.6
Valve spring tension (IN. & EX.)		INNER	4.9–5.8 kg at length 28.5 mm	—
		OUTER	7.2–8.1 kg at length 32.0 mm	—

CAMSHAFT + CYLINDER HEAD

Unit: mm

ITEM		STANDARD		LIMIT
Cam height	E-17,18 22,39	IN.	34.651–34.691	34.36
		EX.	34.357–34.397	34.06
	The others	IN.	35.241–35.281	34.95
		EX.	34.933–34.973	34.64
Camshaft journal oil clearance		IN. & EX.	—	0.150
Camshaft journal holder I.D.		IN. & EX.	22.012–22.025	—
Camshaft journal O.D.		IN. & EX.	21.959–21.980	—
Camshaft runout		IN. & EX.	—	0.10
Cam chain 20-pitch length			—	157.80
Cam chain pin (at arrow "3")			20th pin	—
Rocker arm I.D.		IN. & EX.	12.000–12.018	—
Rocker arm shaft O.D.		IN. & EX.	11.973–11.984	—
Cylinder head distortion			—	0.20

CYLINDER + PISTON + PISTON RING

Unit: mm

ITEM	STANDARD			LIMIT
Compression pressure	1 100–1 500 kPa, (11–15 kg/cm ²)			900 kPa, (9 kg/cm ²)
Compression pressure difference	—			200 kPa, (2 kg/cm ²)
Piston to cylinder clearance	0.050–0.060			0.120
Cylinder bore	74.000–74.015			74.080
Piston diam.	73.945–73.960 Measure at 15 mm from the skirt end.			73.880
Cylinder distortion	—			0.20
Piston ring free end gap	1st	N	Approx. 10.0	8.0
	2nd	N	Approx. 11.0	8.8
Piston ring end gap	1st	0.10–0.25		0.70
	2nd	0.10–0.25		0.70
Piston ring to groove clearance	1st	—		0.180
	2nd	—		0.150
Piston ring groove width	1st	1.01–1.03		—
	2nd	1.21–1.23		—
	Oil	2.01–2.03		—
Piston ring thickness	1st	0.975–0.990		—
	2nd	1.170–1.190		—
Piston pin bore	20.000–20.006			20.030
Piston pin O.D.	19.996–20.000			19.980

CONROD + CRANKSHAFT

Unit: mm

ITEM	STANDARD	LIMIT
Conrod small end I.D	20.006–20.014	20.040
Conrod deflection	—	3.0
Conrod big end side clearance	0.100–0.650	1.0
Crankshaft runout	—	0.10

OIL PUMP

ITEM	STANDARD	LIMIT
Oil pump reduction ratio	1.727 (89/50 x 33/34)	—
Oil pressure (at 60°C, 140°F)	Above 20 kPa (0.20 kg/cm ²) Below 40 kPa (0.40 kg/cm ²) at 3 000 r/min.	—

CLUTCH

Unit: mm

ITEM	STANDARD	LIMIT
Clutch cable play	2–3	—
Drive plate thickness	2.9–3.1	2.6
Drive plate claw width	15.6–15.8	14.8
Driven plate distortion	—	0.10
Clutch spring free length	—	38.5

TRANSMISSION + DRIVE CHAIN

Unit: mm Except ratio

ITEM		STANDARD	LIMIT
Primary reduction ratio		1.780 (89/50)	—
Final reduction ratio	E-24	2.866 (43/15)	—
	The others	2.800 (42/15)	—
Gear ratios	Low	2.500 (35/14)	—
	2nd	1.777 (32/18)	—
	3rd	1.380 (29/21)	—
	4th	1.125 (27/24)	—
	Top	0.961 (25/26)	—
Shift fork to groove clearance		0.40–0.60	0.80
Shift fork groove width		5.45–5.55	—
Shift fork thickness		4.95–5.05	—
Countershaft length (Low to 2nd)		111.5 ± $\begin{smallmatrix} 0 \\ 0.1 \end{smallmatrix}$	—
Drive chain	Type	D.I.D.: 630YL TAKASAGO: RK630GSV	—
	Links	102	—
	20-pitch length	—	383.2
Drive chain slack		15–25	—

CARBURETOR

ITEM	SPECIFICATION	
	E-01,06,24,28	The others
Carburetor type	MIKUNI BS36SS	←
Bore size (venturi)	32 mm	←
I.D. No.	00A30	00A00
Idle r/min.	1 100 ± 50 r/min.	←
Fuel level	3.0 ± 0.5 mm	←
Float height	21.4 ± 1.0 mm	←
Main jet (M.J.)	# 120 (Nos. 1 & 4); # 122.5 (Nos. 2 & 3)	# 120
Main air jet (M.A.J.)	1.2 mm	←
Jet needle (J.N.)	5D59-2nd	←
Needle jet (N.J.)	X-5	←
Throttle valve (Th.V.)	# 130	←
Pilot jet (P.J.)	# 47.5	←
By pass (B.P.)	0.9,0.8,0.9 mm	←
Pilot outlet (P.O.)	0.9 mm	←
Air screw (A.S.)	PRE-SET (2 turns back)	←
Valve seat (V.S.)	2.0 mm	←
Starter jet (G.S.)	# 32.5	←

ITEM	SPECIFICATION	
	E-01,06,24,28	The others
Pilot air jet (P.A.J.)	# 125	—
Throttle cable play	2–3 mm	—
Choke cable play	0.5–1.0 mm	—

ELECTRICAL

ITEM	SPECIFICATION		NOTE
Ignition timing	10° B.T.D.C. Below 1 500 ± 100 r/min and 32° B.T.D.C. Above 3 500 ± 100 r/min.		
Firing order	1.2.4.3.		
Spark plug	Type	N.D.: X27ES-U NGK: D9EA	E-01,24,25, 27,34
	Gap	0.6–0.7	
	Type	N.D.: X27ESR-U NGK: DR8ES	The others
	Gap	0.6–0.7	
Spark performance	Over 8 at 1 atm.		
Signal coil resistance	100–300 Ω		Y-BI, Lg-B
Ignition coil resistance	Primary	2–5 Ω	O/W-W,O/W-BI/Y
	Secondary	30–40 k Ω	Plug cap—Plug cap
Generator no-load voltage	More than 80 V (AC) at 5 000 r/min.		
Generator coil resistance	0.1–1.0 Ω		
Regulated voltage	14.0–15.5 V at 5 000 r/min.		
Starter motor brush length	Limit: 9		N.D.
Commutator under cut	Limit: 0.2		
Starter relay resistance	3–7 Ω		
Battery	Type designation	SYBI4L-B2	
	Capacity	12V50.4kC(14Ah)/10HR	
	Standard electrolyte S.G.	1.28 at 20°C (68°F)	
Fuse size	HEAD	10 A	
	SIGNAL	10 A	
	IGNITION	10 A	
	MAIN	15 A	
	POWER SOURCE	10 A	

WATTAGE

Unit: W

ITEM		SPECIFICATION			
		E-01,24,27	E-06,28	E-02,04,15,17 21,25,34,39	E-16,18,22,26
Headlight	HI	60	←	←	←
	LO	55	←	←	←
Parking or city light				4	←
Tail/Brake light		8/23	←	5/21	←

ITEM	SPECIFICATION			
	E-01,24,27	E-06,28	E-02,04,15,17 21,25,34,39	E-16,18,22,26
Turn signal/position light	23	23/8	21	←
Speedometer light	3.4	←	←	←
Tachometer light	3.4	←	←	←
Fuel and oil temp. meter light	3.4	←	←	←
Turn signal indicator light	3.4	←	←	←
High beam indicator light	1.7	←	←	←
Neutral indicator light	3.4	←	←	←
Oil pressure indicator light	3.4	←	←	←
Side stand check light	3.4	←	←	←
License light	8	←	5	←

BRAKE + WHEEL

Unit: mm

ITEM		STANDARD		LIMIT	
Rear brake pedal height		40		—	
Brake disc thickness	Front	5.0 ± 0.2		4.5	
	Rear	6.7 ± 0.2		6.0	
Brake disc runout		—		0.30	
Master cylinder bore	Front	15.870–15.913		—	
	Rear	15.870–15.913		—	
Master cylinder piston diam.	Front	15.827–15.854		—	
	Rear	15.827–15.854		—	
Brake caliper cylinder bore	Front	38.180–38.256		—	
	Rear	38.180–38.256		—	
Brake caliper piston diam.	Front	38.098–38.148		—	
	Rear	38.098–38.148		—	
Wheel rim runout	Axial	—		2.0	
	Radial	—		2.0	
Wheel axle runout	Front	—		0.25	
	Rear	—		0.25	
Tire size	E-24	Front	120/80 V16		—
		Rear	130/80 V18		—
	The others	Front	110/90 V16		—
		Rear	130/90 V17		—
Tire tread depth	Front	—		1.6	
	Rear	—		2.0	

Unit: mm

SUSPENSION

ITEM	STANDARD	LIMIT	NOTE
Front fork stroke	150	—	
Front fork spring free length	—	500	
Front fork oil level	190	—	
	180	—	Only for E-28
Front fork air pressure	30 kPa (0.3 kg/cm ²)	—	Only for E-28
Rear wheel travel	115	—	
Swing arm pivot shaft runout	—	0.3	

TIRE PRESSURE

COLD INFLATION TIRE PRESSURE	SOLO RIDING		DUAL RIDING	
	kPa	kg/cm ²	kPa	kg/cm ²
FRONT	250	2.50	250	2.50
REAR	250	2.50	290	2.90

FUEL + OIL

ITEM	SPECIFICATION	NOTE
Fuel type	Gasoline used should be graded 85-95 octane or higher. An unleaded or low-lead gasoline type is recommended.	
Fuel tank including reserve	20.0 L	
	4.9 L	
Engine oil type	SAE 10W/40, API SE or SF	
Engine oil capacity	Change	3 200 ml
	Filter change	3 600 ml
	Overhaul	4 000 ml
Front fork oil type	Fork oil # 15	
Front fork oil capacity (each leg)	280 ml	
	286 ml	Only for E-28
Brake fluid type	DOT3, DOT4 or SAE J1703	

**GSX1100EF/ESF/EFF ('85-MODEL)
GS1150EF/ESF/EFF**

CONTENTS

SERVICE DATA	9- 1
GSX1100EF, GS1150EF	9- 1
GSX1100ESF/EFF, GS1150ESF/EFF	9- 7

SERVICE DATA (GSX1100EF, GS1150EF)**VALVE + GUIDE**

Unit: mm

ITEM		STANDARD		LIMIT
Valve diam.	IN.		28.0	—
	EX.		23.0	—
Valve lift	E-22	IN.	7.0	—
		EX.	6.5	—
	The others	IN.	8.0	—
		EX.	7.5	—
Valve clearance (when cold)		IN. & EX.	0.08–0.13	—
Valve stem deflection		IN.	—	0.35
		EX.	—	0.35
Valve guide I.D.		IN. & EX.	5.500–5.512	—
Valve stem O.D.		IN.	5.470–5.487	—
		EX.	5.445–5.460	—
Valve stem runout		IN. & EX.	—	0.05
Valve head thickness		IN. & EX.	—	0.5
Valve stem end length		IN. & EX.	—	3.8
Valve seat width		IN. & EX.	0.9–1.1	—
Valve head radial runout		IN. & EX.	—	0.03
Valve spring free length (IN. & EX.)		INNER	—	31.9
		OUTER	—	35.6
Valve spring tension (IN. & EX.)		INNER	4.9–5.8 kg at length 28.5 mm	—
		OUTER	7.2–8.1 kg at length 32.0 mm	—

CAMSHAFT + CYLINDER HEAD

Unit: mm

ITEM		STANDARD		LIMIT
Cam height	E-22	IN.	34.651–34.691	34.36
		EX.	34.357–34.397	34.06
	The others	IN.	35.241–35.281	34.95
		EX.	34.933–34.973	34.64
Camshaft journal oil clearance		IN. & EX.	—	0.150
Camshaft journal holder I.D.		IN. & EX.	22.012–22.025	—
Camshaft journal O.D.		IN. & EX.	21.959–21.980	—
Camshaft runout		IN. & EX.	—	0.10
Cam chain 20-pitch length			—	157.80
Cam chain pin (at arrow "3")			20th pin	—
Rocker arm I.D.		IN. & EX.	12.000–12.018	—
Rocker arm shaft O.D.		IN. & EX.	11.973–11.984	—
Cylinder head distortion			—	0.20

CYLINDER + PISTON + PISTON RING

Unit: mm

ITEM	STANDARD			LIMIT
Compression pressure	1 100–1 500 kPa, (11–15 kg/cm ²)			900 kPa, (9 kg/cm ²)
Compression pressure difference	—			200 kPa, (2 kg/cm ²)
Piston to cylinder clearance	0.050–0.060			0.120
Cylinder bore	74.000–74.015			74.080
Piston diam.	73.945–73.960 Measure at 15 mm from the skirt end.			73.880
Cylinder distortion	—			0.20
Piston ring free end gap	1st	N	Approx. 10.0	8.0
	2nd	N	Approx. 11.0	8.8
Piston ring end gap	1st		0.10–0.25	0.70
	2nd		0.10–0.25	0.70
Piston ring to groove clearance	1st		—	0.180
	2nd		—	0.150
Piston ring groove width	1st		1.01–1.03	—
	2nd		1.21–1.23	—
	Oil		2.01–2.03	—
Piston ring thickness	1st		0.975–0.990	—
	2nd		1.170–1.190	—
Piston pin bore	20.000–20.006			20.030
Piston pin O.D.	19.996–20.000			19.980

CONROD + CRANKSHAFT

Unit: mm

ITEM	STANDARD	LIMIT
Conrod small end I.D	20.006–20.014	20.040
Conrod deflection	—	3.0
Conrod big end side clearance	0.100–0.650	1.0
Crankshaft runout	—	0.10

OIL PUMP

ITEM	STANDARD	LIMIT
Oil pump reduction ratio	1.727 (89/50 x 33/34)	—
Oil pressure (at 60°C, 140°F)	Above 20 kPa (0.20 kg/cm ²) Below 40 kPa (0.40 kg/cm ²) at 3 000 r/min.	—

CLUTCH

Unit: mm

ITEM	STANDARD	LIMIT
Clutch cable play	2–3	—
Drive plate thickness	2.9–3.1	2.6
Drive plate claw width	15.6–15.8	14.8
Driven plate distortion	—	0.10
Clutch spring free length	—	38.5

TRANSMISSION + DRIVE CHAIN

Unit: mm Except ratio

ITEM		STANDARD	LIMIT
Primary reduction ratio		1.780 (89/50)	—
Final reduction ratio	E-24	2.866 (43/15)	—
	The others	2.800 (42/15)	—
Gear ratios	Low	2.500 (35/14)	—
	2nd	1.777 (32/18)	—
	3rd	1.380 (29/21)	—
	4th	1.125 (27/24)	—
	Top	0.961 (25/26)	—
Shift fork to groove clearance		0.40–0.60	0.80
Shift fork groove width		5.45–5.55	—
Shift fork thickness		4.95–5.05	—
Countershaft length (Low to 2nd)		111.5 ± $\begin{smallmatrix} 0 \\ 0.1 \end{smallmatrix}$	—
Drive chain	Type	D.I.D.: 630YL TAKASAGO: RK630GSV	—
	Links	102	—
	20-pitch length	—	383.2
Drive chain slack		15–25	—

CARBURETOR

ITEM	SPECIFICATION	
	E-01,24,28	The others
Carburetor type	MIKUNI BS36SS	←
Bore size (venturi)	32 mm	←
I.D. No.	00A30	00A00
Idle r/min.	1 100 ± 50 r/min.	←
Fuel level	3.0 ± 0.5 mm	←
Float height	21.4 ± 1.0 mm	←
Main jet (M.J.)	#120 (Nos. 1 & 4); #122.5 (Nos. 2 & 3)	#120
Main air jet (M.A.J.)	1.2 mm	←
Jet needle (J.N.)	5D59-2nd	←
Needle jet (N.J.)	X-5	←
Throttle valve (Th.V.)	#130	←
Pilot jet (P.J.)	#47.5	←
By pass (B.P.)	0.9, 0.8, 0.9 mm	←
Pilot outlet (P.O.)	0.9 mm	←
Air screw (A.S.)	PRE-SET (2 turns back)	←
Valve seat (V.S.)	2.0 mm	←
Starter jet (G.S.)	#32.5	←

ITEM	SPECIFICATION	
	E-01,24,28	The others
Pilot air jet (P.A.J.)	#125	←
Throttle cable play	2–3 mm	←
Choke cable play	0.5–1.0 mm	←

ELECTRICAL

Unit: mm

ITEM	SPECIFICATION		NOTE
Ignition timing	10° B.T.D.C. Below 1 500 ± 100 r/min and 32° B.T.D.C. Above 3 500 ± 100 r/min.		
Firing order	1.2.4.3.		
Spark plug	Type	N.D.: X27EP-U NGK: DP9EA-9	E-01,24
	Gap	0.6–0.7	
	Type	N.D.: X27EPR-U NGK: DPR9EA	The others
	Gap	0.6–0.7	
Spark performance	Over 8 at 1 atm.		
Signal coil resistance	100–300 Ω		Y-BI, Lg-B
Ignition coil resistance	Primary	2–5 Ω	O/W-W,O/W-B/Y
	Secondary	30–40 k Ω	Plug cap—Plug cap
Generator no-load voltage	More than 80 V (AC) at 5 000 r/min.		
Generator coil resistance	0.1–1.0 Ω		
Regulated voltage	14.0–15.5 V at 5 000 r/min.		
Starter motor brush length	Limit: 9		N.D.
Commutator under cut	Limit: 0.2		
Starter relay resistance	3–7 Ω		
Battery	Type designation	SYBI4L-B2	
	Capacity	12V50.4kC(14Ah)/10HR	
	Standard electrolyte S.G.	1.28 at 20°C (68°F)	
Fuse size	HEAD	10 A	
	SIGNAL	10 A	
	IGNITION	10 A	
	MAIN	15 A	
	POWER SOURCE	10 A	

WATTAGE

Unit: W

ITEM		SPECIFICATION				
		E-01	E-24	E-28	E-02,04,21	E-22
Headlight	HI	60	←	←	←	←
	LO	55	←	←	←	←
Parking or position light		/	/	/	4	←
Tail/Brake light		8/23	5/21	8/23	5/21	←
Turn signal light		23	←	23/8	21	←
Meter light		3.4 × 3	←	←	←	←
Turn signal indicator light		3	←	←	←	←
High beam indicator light		3	←	←	←	←
Neutral indicator light		3	←	←	←	←
Oil pressure indicator light		3	←	←	←	←
Side stand check light		3	←	←	←	/
Headlight check light		3	←	←	←	←
Tail/Brake light check light		3	←	←	←	←
Battery check light		3	←	←	←	←
Licence light		8	5	8	5	←

BRAKE + WHEEL

Unit: mm

ITEM	STANDARD		LIMIT
Rear brake pedal height	40		—
Brake disc thickness	Front	5.0 ± 0.2	4.5
	Rear	6.7 ± 0.2	6.0
Brake disc runout	—		0.30
Master cylinder bore	Front	15.870–15.913	—
	Rear	15.870–15.913	—
Master cylinder piston diam.	Front	15.827–15.854	—
	Rear	15.827–15.854	—
Brake caliper cylinder bore	Front	38.180–38.256	—
	Rear	38.180–38.256	—
Brake caliper piston diam.	Front	38.098–38.148	—
	Rear	38.098–38.148	—
Wheel rim runout	Axial	—	2.0
	Radial	—	2.0
Wheel axle runout	Front	—	0.25
	Rear	—	0.25
Tire size	Front	110/90 V16	—
	Rear	130/90 V17	—
Tire tread depth	Front	—	1.6
	Rear	—	2.0

SUSPENSION

Unit: mm

ITEM	STANDARD	LIMIT	NOTE
Front fork stroke	150	—	
Front fork spring	—	504	
	—	500	Only for E-28
Front fork oil level	210	—	
	180	—	Only for E-28
Front fork air pressure	30 kPa (0.3 kg/cm ²)	—	Only for E-28
Rear wheel travel	115	—	
Swingarm pivot shaft runout	—	0.3	

TIRE PRESSURE

COLD INFLATION TIRE PRESSURE	SOLO RIDING		DUAL RIDING	
	kPa	kg/cm ²	kPa	kg/cm ²
FRONT	250	2.50	250	2.50
REAR	250	2.50	290	2.90

FUEL + OIL

ITEM	SPECIFICATION	NOTE
Fuel type	Gasoline used should be graded 85-95 octane or higher. An unleaded or low-lead gasoline type is recommended.	
Fuel tank including reserve	20.0 L	
reserve	4.9 L	
Engine oil type	SAE 10W/40, API SE or SF	
Engine oil capacity	Change	3 200 ml
	Filter change	3 600 ml
	Overhaul	4 000 ml
Front fork oil type	Fork oil # 15	
Front fork oil capacity (each leg)	268 ml	
	286 ml	Only for E-28
Brake fluid type	DOT3, DOT4 or SAE J1703	

GSX1100ESF/EFF, GS1150ESF/EFF**VALVE + GUIDE**

Unit: mm

ITEM		STANDARD		LIMIT
Valve diam.	IN.		28.0	—
	EX.		23.0	—
Valve lift	E-18, 22	IN.	7.0	—
		EX.	6.5	—
	The others	IN.	8.0	—
		EX.	7.5	—
Valve clearance (when cold)		IN. & EX.	0.08–0.13	—
Valve guide to valve stem clearance		IN.	—	0.35
		EX.	—	0.35
Valve guide I.D.		IN. & EX.	5.500–5.512	—
Valve stem O.D.		IN.	5.470–5.487	—
		EX.	5.445–5.460	—
Valve stem runout		IN. & EX.	—	0.05
Valve head thickness		IN. & EX.	—	0.5
Valve stem end length		IN. & EX.	—	3.8
Valve seat width		IN. & EX.	0.9–1.1	—
Valve head radial runout		IN. & EX.	—	0.03
Valve spring free length (IN. & EX.)		INNER	—	31.9
		OUTER	—	35.6
Valve spring tension (IN. & EX.)		INNER	4.9–5.8 kg at length 28.5 mm	—
		OUTER	7.2–8.1 kg at length 32.0 mm	—

CAMSHAFT + CYLINDER HEAD

Unit: mm

ITEM		STANDARD		LIMIT
Cam height	E-18, 22	IN.	34.651–34.691	34.36
		EX.	34.357–34.397	34.06
	The others	IN.	35.241–35.281	34.95
		EX.	34.933–34.973	34.64
Camshaft journal oil clearance		IN. & EX.	—	0.150
Camshaft journal holder I.D.		IN. & EX.	22.012–22.025	—
Camshaft journal O.D.		IN. & EX.	21.959–21.980	—
Camshaft runout		IN. & EX.	—	0.10
Cam chain 20-pitch length			—	157.80
Cam chain pin (at arrow "3")			20th pin	—
Rocker arm I.D.		IN. & EX.	12.000–12.018	—
Rocker arm shaft O.D.		IN. & EX.	11.973–11.984	—
Cylinder head distortion			—	0.20

CYLINDER + PISTON + PISTON RING

Unit: mm

ITEM	STANDARD			LIMIT
Compression pressure	1 100–1 500 kPa, (11–15 kg/cm ²)			900 kPa, (9 kg/cm ²)
Compression pressure difference	—			200 kPa, (2 kg/cm ²)
Piston to cylinder clearance	0.050–0.060			0.120
Cylinder bore	74.000–74.015			74.080
Piston diam.	73.945–73.960 Measure at 15 mm from the skirt end.			73.880
Cylinder distortion	—			0.20
Piston ring free end gap	1st	N	Approx. 10.0	8.0
	2nd	N	Approx. 11.0	8.8
Piston ring end gap	1st		0.10–0.25	0.70
	2nd		0.10–0.25	0.70
Piston ring to groove clearance	1st		—	0.180
	2nd		—	0.150
Piston ring groove width	1st		1.01–1.03	—
	2nd		1.21–1.23	—
	Oil		2.01–2.03	—
Piston ring thickness	1st		0.975–0.990	—
	2nd		1.170–1.190	—
Piston pin bore	20.000–20.006			20.030
Piston pin O.D.	19.996–20.000			19.980

CONROD + CRANKSHAFT

Unit: mm

ITEM	STANDARD	LIMIT
Conrod small end I.D	20.006–20.014	20.040
Conrod deflection	—	3.0
Conrod big end side clearance	0.100–0.650	1.0
Crankshaft runout	—	0.10

OIL PUMP

ITEM	STANDARD	LIMIT
Oil pump reduction ratio	1.727 (89/50 x 33/34)	—
Oil pressure (at 60°C, 140°F)	Above 20 kPa (0.20 kg/cm ²) Below 40 kPa (0.40 kg/cm ²) at 3 000 r/min.	—

CLUTCH

Unit: mm

ITEM	STANDARD	LIMIT
Clutch cable play	2–3	—
Drive plate thickness	2.9–3.1	2.6
Drive plate claw width	15.6–15.8	14.8
Driven plate distortion	—	0.10
Clutch spring free length	—	38.5

TRANSMISSION + DRIVE CHAIN

Unit: mm Except ratio

ITEM		STANDARD	LIMIT
Primary reduction ratio		1.780 (89/50)	—
Final reduction ratio	E-24	2.866 (43/15)	—
	The others	2.800 (42/15)	—
Gear ratios	Low	2.500 (35/14)	—
	2nd	1.777 (32/18)	—
	3rd	1.380 (29/21)	—
	4th	1.125 (27/24)	—
	Top	0.961 (25/26)	—
Shift fork to groove clearance		0.40–0.60	0.80
Shift fork groove width		5.45–5.55	—
Shift fork thickness		4.95–5.05	—
Countershaft length (Low to 2nd)		111.5 ± _{0.1} ⁰	—
Drive chain	Type	D.I.D.: 630YL TAKASAGO: RK630GSV	—
	Links	102	—
	20-pitch length	—	383.2
Drive chain slack		15–25	—

CARBURETOR

ITEM	SPECIFICATION			
	E-01,06,24,28	E-17,39	E-18	The others
Carburetor type	MIKUNI BS36SS	←	←	←
Bore size (venturi)	36 mm	←	←	←
I.D. No.	00A30	00A50	00A20	00A00
Idle r/min.	1100 ± 50 r/min.	←	←	←
Fuel level	3.0 ± 0.5 mm	←	←	←
Float height	21.4 ± 1.0 mm	←	←	←
Main jet (M.J.)	#120(Nos. 1 & 4); #122.5 (Nos. 2 & 4)	←	#120	←
Main air jet (M.A.J.)	1.2 mm	←	←	←
Jet needle (J.N.)	5D59-2nd	←	←	←
Needle jet (N.J.)	X-5	←	←	←
Throttle valve (Th.V.)	#130	←	←	←
Pilot jet (P.J.)	#47.5	←	←	←
By pass (B.P.)	0.9,0.8,0.9 mm	←	←	←
Pilot outlet (P.O.)	0.9 mm	←	←	←
Pilot screw (P.S.)	PRE-SET (2 turns back)	←	←	←
Valve seat (V.S.)	2.0 mm	←	←	←
Starter jet (G.S.)	#32.5	←	←	←
Pilot air jet (P.A.J.)	#125	←	←	←
Throttle cable play	2–3 mm	←	←	←
Choke cable play	0.5–1.0 mm	←	←	←

ELECTRICAL

ITEM		SPECIFICATION		NOTE
Ignition timing		10° B.T.D.C. Below 1 500 ± 100 r/min and 32° B.T.D.C. Above 3 500 ± 100 r/min.		
Firing order		1.2.4.3.		
Spark plug	Type	N.D.: X27ES-U NGK: D9EA		E-01,24,25, 34
	Gap	0.6–0.7		
	Type	N.D.: X27ESR-U NGK: DR8ES		The others
	Gap	0.6–0.7		
Spark performance		Over 8 at 1 atm.		
Signal coil resistance		100–300 Ω		Y-BI, Lg-B
Ignition coil resistance	Primary	2–5 Ω		O/W-W,O/W-BI/Y
	Secondary	30–40 k Ω		Plug cap—Plug cap
Generator no-load voltage		More than 80 V (AC) at 5 000 r/min.		
Generator coil resistance		0.1–1.0 Ω		
Regulated voltage		14.0–15.5 V at 5 000 r/min.		
Starter motor brush length		Limit: 9		N.D.
Commutator under cut		Limit: 0.2		
Starter relay resistance		3–7 Ω		
Battery	Type designation	SYBI4L-B2		
	Capacity	12V50.4kC(14Ah)/10HR		
	Standard electrolyte S.G.	1.28 at 20°C (68°F)		
Fuse size	HEAD	10 A		
	SIGNAL	10 A		
	IGNITION	10 A		
	MAIN	15 A		
	POWER SOURCE	10 A		

WATTAGE

Unit: W

ITEM		SPECIFICATION			
		E-01,06,24	E-28	E-02,04, 17,21,25, 34,39	E-15,16, 18,22,26
Headlight	HI	60	←	←	←
	LO	55	←	←	←
Parking or position light				4	←
Tail/Brake light		8/23	←	5/21	←
Turn signal light		23	23/8	21	←
Meter light		3.4 × 3	←	←	←
Turn signal indicator light		3	←	←	←
High beam indicator light		3	←	←	←
Neutral indicator light		3	←	←	←
Oil pressure indicator light		3	←	←	←

ITEM	SPECIFICATION			
	E-01,06,24	E-28	E-02,04, 17,21,25, 34,39	E-15,16, 18,22,26
Side stand check light	3	←	←	←
Headlight check light	3	←	←	←
Tail/Brake light check light	3	←	←	←
Battery check light	3	←	←	←
Licence light	8	←	5	←

BRAKE + WHEEL

Unit: mm

ITEM		STANDARD		LIMIT
Rear brake pedal height		40		—
Brake disc thickness		Front	5.0 ± 0.2	4.5
		Rear	6.7 ± 0.2	6.0
Brake disc runout		—		0.30
Master cylinder bore		Front	15.870–15.913	—
		Rear	15.870–15.913	—
Master cylinder piston diam.		Front	15.827–15.854	—
		Rear	15.827–15.854	—
Brake caliper cylinder bore		Front	38.180–38.256	—
		Rear	38.180–38.256	—
Brake caliper piston diam.		Front	38.098–38.148	—
		Rear	38.098–38.148	—
Wheel rim runout		Axial	—	2.0
		Radial	—	2.0
Wheel axle runout		Front	—	0.25
		Rear	—	0.25
Tire size	E-24	Front	120/80 V 16	—
		Rear	130/80 V 18	—
	The others	Front	110/90 V 16	—
		Rear	130/90 V 17	—
Tire tread depth		Front	—	1.6
		Rear	—	2.0

SUSPENSION

Unit: mm

ITEM	STANDARD	LIMIT	NOTE
Front fork stroke	150	—	
Front fork spring free length	—	500	
Front fork oil level	190	—	
	180	—	Only for E-28
Front fork air pressure	30 kPa (0.3 kg/cm ²)	—	Only for E-28
Rear wheel travel	115	—	
Swingarm pivot shaft runout	—	0.3	

TIRE PRESSURE

COLD INFLATION TIRE PRESSURE	SOLO RIDING		DUAL RIDING	
	kPa	kg/cm ²	kPa	kg/cm ²
FRONT	250	2.50	250	2.50
REAR	250	2.50	290	2.90

FUEL + OIL

ITEM	SPECIFICATION		NOTE
Fuel type	Gasoline used should be graded 85-95 octane or higher. An unleaded or low-lead gasoline type is recommended.		
Fuel tank including reserve	20.0 L		
reserve	4.9 L		
Engine oil type	SAE 10W/40, API SE or SF		
Engine oil capacity	Change	3 200 ml	
	Filter change	3 600 ml	
	Overhaul	4 000 ml	
Front fork oil type	Fork oil # 15		
Front fork oil capacity (each leg)	280 ml		
	286 ml		Only for E-28
Brake fluid type	DOT3, DOT4 or SAE J1703		

NUMBER + P
TIMU

CONTENTS

SERVICE DATA	10- 1
GSX1100EG, GS1150EG	10- 1
GSX1100ESG/EFG, GSX1150EFG, GS1150EFG	10- 7

SERVICE DATA (GSX1100EG, GS1150EG)**VALVE + GUIDE**

Unit: mm

ITEM		STANDARD		LIMIT
Valve diam.	IN.		28.0	—
	EX.		23.0	—
Valve lift	E-22	IN.	7.0	—
		EX.	6.5	—
	The others	IN.	8.0	—
		EX.	7.5	—
Valve clearance (when cold)		IN. & EX.	0.08–0.13	—
Valve stem deflection		IN.	—	0.35
		EX.	—	0.35
Valve guide I.D.		IN. & EX.	5.500–5.512	—
Valve stem O.D.		IN.	5.470–5.487	—
		EX.	5.445–5.460	—
Valve stem runout		IN. & EX.	—	0.05
Valve head thickness		IN. & EX.	—	0.5
Valve stem end length		IN. & EX.	—	3.8
Valve seat width		IN. & EX.	0.9–1.1	—
Valve head radial runout		IN. & EX.	—	0.03
Valve spring free length (IN. & EX.)		INNER	—	31.9
		OUTER	—	35.6
Valve spring tension (IN. & EX.)		INNER	4.9–5.8 kg at length 28.5 mm	—
		OUTER	7.2–8.1 kg at length 32.0 mm	—

CAMSHAFT + CYLINDER HEAD

Unit: mm

ITEM		STANDARD		LIMIT
Cam height	E-22	IN.	34.651–34.691	34.36
		EX.	34.357–34.397	34.06
	The others	IN.	35.241–35.281	34.95
		EX.	34.933–34.973	34.64
Camshaft journal oil clearance		IN. & EX.	—	0.150
Camshaft journal holder I.D.		IN. & EX.	22.012–22.025	—
Camshaft journal O.D.		IN. & EX.	21.959–21.980	—
Camshaft runout		IN. & EX.	—	0.10
Cam chain 20-pitch length			—	157.80
Cam chain pin (at arrow "3")			20th pin	—
Rocker arm I.D.		IN. & EX.	12.000–12.018	—
Rocker arm shaft O.D.		IN. & EX.	11.973–11.984	—
Cylinder head distortion			—	0.20

CYLINDER + PISTON + PISTON RING

Unit: mm

ITEM	STANDARD			LIMIT
Compression pressure	1 100–1 500 kPa, (11–15 kg/cm ²)			900 kPa (9 kg/cm ²)
Compression pressure difference	—			200 kPa (2 kg/cm ²)
Piston to cylinder clearance	0.050–0.060			0.120
Cylinder bore	74.000–74.015			74.080
Piston diam.	73.945–73.960 Measure at 15 mm from the skirt end.			73.880
Cylinder distortion	—			0.20
Piston ring free end gap	1st	N	Approx. 10.0	8.0
	2nd	N	Approx. 11.0	8.8
Piston ring end gap	1st	0.10–0.25		0.70
	2nd	0.10–0.25		0.70
Piston ring to groove clearance	1st	—		0.180
	2nd	—		0.150
Piston ring groove width	1st	1.01–1.03		—
	2nd	1.21–1.23		—
	Oil	2.01–2.03		—
Piston ring thickness	1st	0.975–0.990		—
	2nd	1.170–1.190		—
Piston pin bore	20.000–20.006			20.030
Piston pin O.D.	19.996–20.000			19.980

CONROD + CRANKSHAFT

Unit: mm

ITEM	STANDARD			LIMIT
Conrod small end I.D	20.006–20.014			20.040
Conrod deflection	—			3.0
Conrod big end side clearance	0.100–0.650			1.0
Crankshaft runout	—			0.10

OIL PUMP

ITEM	STANDARD			LIMIT
Oil pump reduction ratio	1.727 (89/50 × 33/34)			—
Oil pressure (at 60°C, 140°F)	Above 20 kPa (0.20 kg/cm ²) Below 40 kPa (0.40 kg/cm ²) at 3 000 r/min.			—

CLUTCH

Unit: mm

ITEM	STANDARD			LIMIT
Clutch cable play	2–3			—
Drive plate thickness	2.9–3.1			2.6
Drive plate claw width	15.6–15.8			14.8
Driven plate distortion	—			0.10
Clutch spring free length	—			38.5

TRANSMISSION + DRIVE CHAIN

Unit: mm (Except ratio)

ITEM		STANDARD	LIMIT
Primary reduction ratio		1.780 (89/50)	—
Final reduction ratio		2.800 (42/15)	—
Gear ratios	Low	2.500 (35/14)	—
	2nd	1.777 (32/18)	—
	3rd	1.380 (29/21)	—
	4th	1.125 (27/24)	—
	Top	0.961 (25/26)	—
Shift fork to groove clearance		0.40–0.60	0.80
Shift fork groove width		5.45–5.55	—
Shift fork thickness		4.95–5.05	—
Countershaft length (Low to 2nd)		111.5 ± $\begin{matrix} 0 \\ 0.1 \end{matrix}$	—
Drive chain	Type	D.I.D.: 630YL TAKASAGO: RK630GSV	—
	Links	102	—
	20-pitch length	—	383.2
Drive chain slack		15–25	—

CARBURETOR

ITEM	SPECIFICATION	
	E-28	The others
Carburetor type	MIKUNI BS36SS	←
Bore size	36 mm	←
I.D. No.	00A30	00A00
Idle r/min.	1 100 ± 50 r/min.	←
Fuel level	3.0 ± 0.5 mm	←
Float height	21.4 ± 1.0 mm	←
Main jet (M.J.)	#120 (Nos. 1 & 4) #122.5 (Nos. 2 & 3)	#120
Main air jet (M.A.J.)	1.2 mm	←
Jet needle (J.N.)	5D59-2nd	←
Needle jet (N.J.)	X-5	←
Throttle valve (Th.V.)	#130	←
Pilot jet (P.J.)	#47.5	←
By-pass (B.P.)	0.9, 0.8, 0.9 mm	←
Pilot outlet (P.O.)	0.9 mm	←
Air screw (A.S.)	PRE-SET (2 turns back)	←
Valve seat (V.S.)	2.0 mm	←
Starter jet (G.S.)	#32.5	←
Pilot air jet (P.A.J.)	#125	←
Throttle cable play	2–3 mm	←
Choke cable play	0.5–1.0 mm	←

ELECTRICAL

Unit: mm

ITEM		SPECIFICATION		NOTE
Ignition timing		10° B.T.D.C. Below 1 500 ± 100 r/min. and 32° B.T.D.C. Above 3 500 ± 100 r/min.		
Firing order		1.2.4.3.		
Spark plug	Type	N.D.: X27ESR-U NGK: DR8ES		
	Gap	0.6–0.7		
Spark performance		Over 8 at 1 atm.		
Signal coil resistance		100–300 Ω		Y-BI, Lg-B
Ignition coil resistance	Primary	2–5 Ω		O/W-W, O/W-B/Y
	Secondary	30–40 kΩ		Plug cap-Plug cap
Generator no-load voltage		More than 80 V (AC) at 5 000 r/min.		
Generator coil resistance		0.1–1.0 Ω		
Regulated voltage		14.0–15.5 V at 5 000 r/min.		
Starter motor brush length		Limit: 9		N.D.
Commutator under-cut		Limit: 0.2		
Starter relay resistance		3–7 Ω		
Battery	Type designation	SYB14L-B2		
	Capacity	12 V 50.4 kC (14 Ah)/10 HR		
	Standard electrolyte S.G.	1.28 at 20°C (68°F)		
Fuse size	HEAD	10 A		
	SIGNAL	10 A		
	IGNITION	10 A		
	MAIN	15 A		
	POWER SOURCE	10 A		

WATTAGE

Unit: W

ITEM		SPECIFICATION		
		E-28	E-02	E-22
Headlight	HI	60	←	←
	LO	55	←	←
Parking or position light			4	←
Tail/Brake light		8/23	5/21	←
Turn signal light		23/8	21	←
Meter light		3.4 × 3	←	←
Turn signal indicator light		3	←	←
High beam indicator light		3	←	←
Neutral indicator light		3	←	←
Oil pressure indicator light		3	←	←
Side stand check light		3	←	
Headlight check light		3	←	←
Tail/Brake light check light		3	←	←

ITEM	SPECIFICATION		
	E-28	E-02	E-22
Battery check light	3	←	←
License light	8	5	←

BRAKE + WHEEL

Unit: mm

ITEM	STANDARD		LIMIT
Rear brake pedal height	40		—
Brake disc thickness	Front	5.0 ± 0.2	4.5
	Rear	6.7 ± 0.2	6.0
Brake disc runout	—		0.30
Master cylinder bore	Front	15.870–15.913	—
	Rear	15.870–15.913	—
Master cylinder piston diam.	Front	15.827–15.854	—
	Rear	15.827–15.854	—
Brake caliper cylinder bore	Front	38.180–38.256	—
	Rear	38.180–38.256	—
Brake caliper piston diam.	Front	38.098–38.148	—
	Rear	38.098–38.148	—
Wheel rim runout	Axial	—	2.0
	Radial	—	2.0
Wheel axle runout	Front	—	0.25
	Rear	—	0.25
Tire size	Front	110/90 V16	—
	Rear	130/90 V17	—
Tire tread depth	Front	—	1.6
	Rear	—	2.0

SUSPENSION

Unit: mm

ITEM	STANDARD	LIMIT	NOTE
Front fork stroke	150	—	
Front fork spring free length	—	504	
	—	500	Only for E-28
Front fork oil level	210	—	
	180	—	Only for E-28
Front fork air pressure	30 kPa (0.3 kg/cm ²)	—	Only for E-28
Rear wheel travel	115	—	
Swingarm pivot shaft runout	—	0.3	

TIRE PRESSURE

COLD INFLATION TIRE PRESSURE	SOLO RIDING		DUAL RIDING	
	kPa	kg/cm ²	kPa	kg/cm ²
FRONT	250	2.50	250	2.50
REAR	250	2.50	290	2.90

FUEL + OIL

ITEM	SPECIFICATION		NOTE
Fuel type	Gasoline used should be graded 85-95 octane or higher. An unleaded or low-lead type gasoline is recommended.		
Fuel tank including reserve	20.0 L		
reserve	4.9 L		
Engine oil type	SAE 10W/40, API SE or SF		
Engine oil capacity	Change	3 200 ml	
	Filter change	3 600 ml	
	Overhaul	4 000 ml	
Front fork oil type	Fork oil #15		
Front fork oil capacity (each leg)	268 ml		
	286 ml		Only for E-28
Brake fluid type	DOT3, DOT4 or SAE J1703		

GSX1100ESG/EFG, GSX1150EFG, GS1150EFG**VALVE + GUIDE**

Unit: mm

ITEM		STANDARD		LIMIT
Valve diam.	IN.		28.0	—
	EX.		23.0	—
Valve lift	E-18, 22	IN.	7.0	—
		EX.	6.5	—
	The others	IN.	8.0	—
		EX.	7.5	—
Valve clearance (when cold)		IN. & EX.	0.08–0.13	—
Valve guide to valve stem clearance		IN.	—	0.35
		EX.	—	0.35
Valve guide I.D.		IN. & EX.	5.500–5.512	—
Valve stem O.D.		IN.	5.470–5.487	—
		EX.	5.445–5.460	—
Valve stem runout		IN. & EX.	—	0.05
Valve head thickness		IN. & EX.	—	0.5
Valve stem end length		IN. & EX.	—	3.8
Valve seat width		IN. & EX.	0.9–1.1	—
Valve head radial runout		IN. & EX.	—	0.03
Valve spring free length (IN. & EX.)		INNER	—	31.9
		OUTER	—	35.6
Valve spring tension (IN. & EX.)		INNER	4.9–5.8 kg at length 28.5 mm	—
		OUTER	7.2–8.1 kg at length 32.0 mm	—

CAMSHAFT + CYLINDER HEAD

Unit: mm

ITEM		STANDARD		LIMIT
Cam height	E-18, 22	IN.	34.651–34.691	34.36
		EX.	34.357–34.397	34.06
	The others	IN.	35.241–35.281	34.95
		EX.	34.933–34.973	34.64
Camshaft journal oil clearance		IN. & EX.	—	0.150
Camshaft journal holder I.D.		IN. & EX.	22.012–22.025	—
Camshaft journal O.D.		IN. & EX.	21.959–21.980	—
Camshaft runout		IN. & EX.	—	0.10
Cam chain 20-pitch length			—	157.80
Cam chain pin (at arrow "3")			20th pin	—
Rocker arm I.D.		IN. & EX.	12.000–12.018	—
Rocker arm shaft O.D.		IN. & EX.	11.973–11.984	—
Cylinder head distortion			—	0.20

CYLINDER + PISTON + PISTON RING

Unit: mm

ITEM	STANDARD			LIMIT
Compression pressure	1 100–1 500 kPa, (11–15 kg/cm ²)			900 kPa, (9 kg/cm ²)
Compression pressure difference	—			200 kPa, (2 kg/cm ²)
Piston to cylinder clearance	0.050–0.060			0.120
Cylinder bore	74.000–74.015			74.080
Piston diam.	73.945–73.960 Measure at 15 mm from the skirt end.			73.880
Cylinder distortion	—			0.20
Piston ring free end gap	1st	N	Approx. 10.0	8.0
	2nd	N	Approx. 11.0	8.8
Piston ring end gap	1st		0.10–0.25	0.70
	2nd		0.10–0.25	0.70
Piston ring to groove clearance	1st		—	0.180
	2nd		—	0.150
Piston ring groove width	1st		1.01–1.03	—
	2nd		1.21–1.23	—
	Oil		2.01–2.03	—
Piston ring thickness	1st		0.975–0.990	—
	2nd		1.170–1.190	—
Piston pin bore	20.000–20.006			20.030
Piston pin O.D.	19.996–20.000			19.980

CONROD + CRANKSHAFT

Unit: mm

ITEM	STANDARD	LIMIT
Conrod small end I.D.	20.006–20.014	20.040
Conrod deflection	—	3.0
Conrod big end side clearance	0.10–0.65	1.0
Crankshaft runout	—	0.10

OIL PUMP

ITEM	STANDARD	LIMIT
Oil pump reduction ratio	1.727 (89/50 x 33/34)	—
Oil pressure (at 60°C, 140°F)	Above 20 kPa (0.20 kg/cm ²) Below 40 kPa (0.40 kg/cm ²) at 3 000 r/min.	—

CLUTCH

Unit: mm

ITEM	STANDARD	LIMIT
Clutch cable play	2–3	—
Drive plate thickness	2.9–3.1	2.6
Drive plate claw width	15.6–15.8	14.8
Driven plate distortion	—	0.10
Clutch spring free length	—	38.5

TRANSMISSION + DRIVE CHAIN

Unit: mm (Except ratio)

ITEM		STANDARD	LIMIT
Primary reduction ratio		1.780 (89/50)	—
Final reduction ratio	E-24	2.866 (43/15)	—
	The others	2.800 (42/15)	—
Gear ratios	Low	2.500 (35/14)	—
	2nd	1.777 (32/18)	—
	3rd	1.380 (29/21)	—
	4th	1.125 (27/24)	—
	Top	0.961 (25/26)	—
Shift fork to groove clearance		0.40–0.60	0.80
Shift fork groove width		5.45–5.55	—
Shift fork thickness		4.95–5.05	—
Countershaft length (Low to 2nd)		111.5 ± 0.1	—
Drive chain	Type	D.I.D.: 630YL TAKASAGO: RK630GSV	—
	Links	102	—
	20-pitch length	—	383.2
Drive chain slack		15–25	—

CARBURETOR

ITEM	SPECIFICATION			
	E-01,06,24,28	E-17,39	E-18	The others
Carburetor type	MIKUNI BS36SS	←	←	←
Bore size (venturi)	36 mm	←	←	←
I.D. No.	00A30	00A50	00A20	00A00
Idle r/min.	1100 ± 50 r/min.	←	←	←
Fuel level	3.0 ± 0.5 mm	←	←	←
Float height	21.4 ± 1.0 mm	←	←	←
Main jet (M.J.)	#120(Nos. 1 & 4) #122.5 (Nos. 2 & 3)	←	#120	←
Main air jet (M.A.J.)	1.2 mm	←	←	←
Jet needle (J.N.)	5D59-2nd	←	←	←
Needle jet (N.J.)	X-5	←	←	←
Throttle valve (Th.V.)	#130	←	←	←
Pilot jet (P.J.)	#47.5	←	←	←
By pass (B.P.)	0.9,0.8,0.9 mm	←	←	←
Pilot outlet (P.O.)	0.9 mm	←	←	←
Pilot screw (P.S.)	PRE-SET (2 turns back)	←	←	←
Valve seat (V.S.)	2.0 mm	←	←	←
Starter jet (G.S.)	#32.5	←	←	←
Pilot air jet (P.A.J.)	#125	←	←	←
Throttle cable play	2–3 mm	←	←	←
Choke cable play	0.5–1.0 mm	←	←	←

ELECTRICAL

Unit: mm

ITEM	SPECIFICATION		NOTE
Ignition timing	10° B.T.D.C. Below 1 500 ± 100 r/min and 32° B.T.D.C. Above 3 500 ± 100 r/min.		
Firing order	1.2.4.3.		
Spark plug	Type	N.D.: X27ES-U NGK: D9EA	E-01,24,25, 34
	Gap	0.6–0.7	
	Type	N.D.: X27ESR-U NGK: DR8ES	The others
	Gap	0.6–0.7	
Spark performance	Over 8 at 1 atm.		
Signal coil resistance	100–300 Ω		Y-BI, Lg-B
Ignition coil resistance	Primary	2–5 Ω	O/W-W,O/W-BI/Y
	Secondary	30–40 k Ω	Plug cap–Plug cap
Generator no-load voltage	More than 80 V (AC) at 5 000 r/min.		
Generator coil resistance	0.1–1.0 Ω		
Regulated voltage	14.0–15.5 V at 5 000 r/min.		
Starter motor brush length	Limit: 9		N.D.
Commutator under cut	Limit: 0.2		
Starter relay resistance	3–7 Ω		
Battery	Type designation	SYBI4L-B2	
	Capacity	12V50.4kC(14Ah)/10HR	
	Standard electrolyte S.G.	1.28 at 20°C (68°F)	
Fuse size	HEAD	10 A	
	SIGNAL	10 A	
	IGNITION	10 A	
	MAIN	15 A	
	POWER SOURCE	10 A	

WATTAGE

Unit: W

ITEM		SPECIFICATION			
		E-01,06,24	E-28	E-02,04, 17,21,25, 34,39	E-15,16, 18,22
Headlight	HI	60	←	←	←
	LO	55	←	←	←
Parking or position light				4	←
Tail/Brake light		8/23	←	5/21	←
Turn signal light		23	23/8	21	←
Meter light		3.4 × 3	←	←	←
Turn signal indicator light		3	←	←	←
High beam indicator light		3	←	←	←
Neutral indicator light		3	←	←	←
Oil pressure indicator light		3	←	←	←

ITEM	SPECIFICATION			
	E-01,06,24	E-28	E-02,04, 17,21,25, 34,39	E-15,16, 18,22
Side stand check light	3	←	←	←
Headlight check light	3	←	←	←
Tail/Brake light check light	3	←	←	←
Battery check light	3	←	←	←
Licence light	8	←	5	←

BRAKE + WHEEL

Unit: mm

ITEM		STANDARD		LIMIT
Rear brake pedal height		40		—
Brake disc thickness		Front	5.0 ± 0.2	4.5
		Rear	6.7 ± 0.2	6.0
Brake disc runout		—		0.30
Master cylinder bore		Front	15.870–15.913	—
		Rear	15.870–15.913	—
Master cylinder piston diam.		Front	15.827–15.854	—
		Rear	15.827–15.854	—
Brake caliper cylinder bore		Front	38.180–38.256	—
		Rear	38.180–38.256	—
Brake caliper piston diam.		Front	38.098–38.148	—
		Rear	38.098–38.148	—
Wheel rim runout		Axial	—	2.0
		Radial	—	2.0
Wheel axle runout		Front	—	0.25
		Rear	—	0.25
Tire size	E-24	Front	120/80 V 16	—
		Rear	130/80 V 18	—
	The others	Front	110/90 V 16	—
		Rear	130/90 V 17	—
Tire tread depth		Front	—	1.6
		Rear	—	2.0

SUSPENSION

Unit: mm

ITEM	STANDARD	LIMIT	NOTE
Front fork stroke	150	—	
Front fork spring free length	—	500	
Front fork oil level	190	—	
	180	—	Only for E-28
Front fork air pressure	30 kPa (0.3 kg/cm ²)	—	Only for E-28
Rear wheel travel	115	—	
Swingarm pivot shaft runout	—	0.3	

TIRE PRESSURE

For E-24

COLD INFLATION TIRE PRESSURE	SOLO RIDING		DUAL RIDING	
	kPa	kg/cm ²	kPa	kg/cm ²
FRONT	225	2.25	250	2.50
REAR	250	2.50	290	2.90

For the others

COLD INFLATION TIRE PRESSURE	SOLO RIDING		DUAL RIDING	
	kPa	kg/cm ²	kPa	kg/cm ²
FRONT	250	2.50	250	2.50
REAR	250	2.50	290	2.90

FUEL + OIL

ITEM	SPECIFICATION		NOTE
Fuel type	Gasoline used should be graded 85-95 octane or higher. An unleaded or low-lead gasoline type is recommended.		
Fuel tank including reserve	20.0 L		
reserve	4.9 L		
Engine oil type	SAE 10W/40, API SE or SF		
Engine oil capacity	Change	3 200 ml	
	Filter change	3 600 ml	
	Overhaul	4 000 ml	
Front fork oil type	Fork oil # 15		
Front fork oil capacity (each leg)	280 ml		
	286 ml		Only for E-28
Brake fluid type	DOT3, DOT4 or SAE J1703		

APPENDIX

CONTENTS

<i>IGNITION COIL INSPECTION METHOD</i>	<i>11- 1</i>
--	--------------

IGNITION COIL INSPECTION METHOD

The sparking performance of the ignition coil can be more clearly inspected with the new method than old one.

INSPECTION

NOTE:

Make sure that the three-needle sparking distance of electro tester is set at 8 mm.

- Remove the ignition coil from the frame.
- With the tester and jumper wire, test the ignition coil for sparking performance in accordance with the following two steps.

STEP ① : Connect the jumper wire to the spark plug cap and ignition coil ground.

STEP ② : Switch over the jumper wire to the other plug cap and ground.

If no sparking or orange color sparking occurs in the above conditions, it may be caused by defective coil.

09900-28106	Electro tester
STD spark performance	8 mm

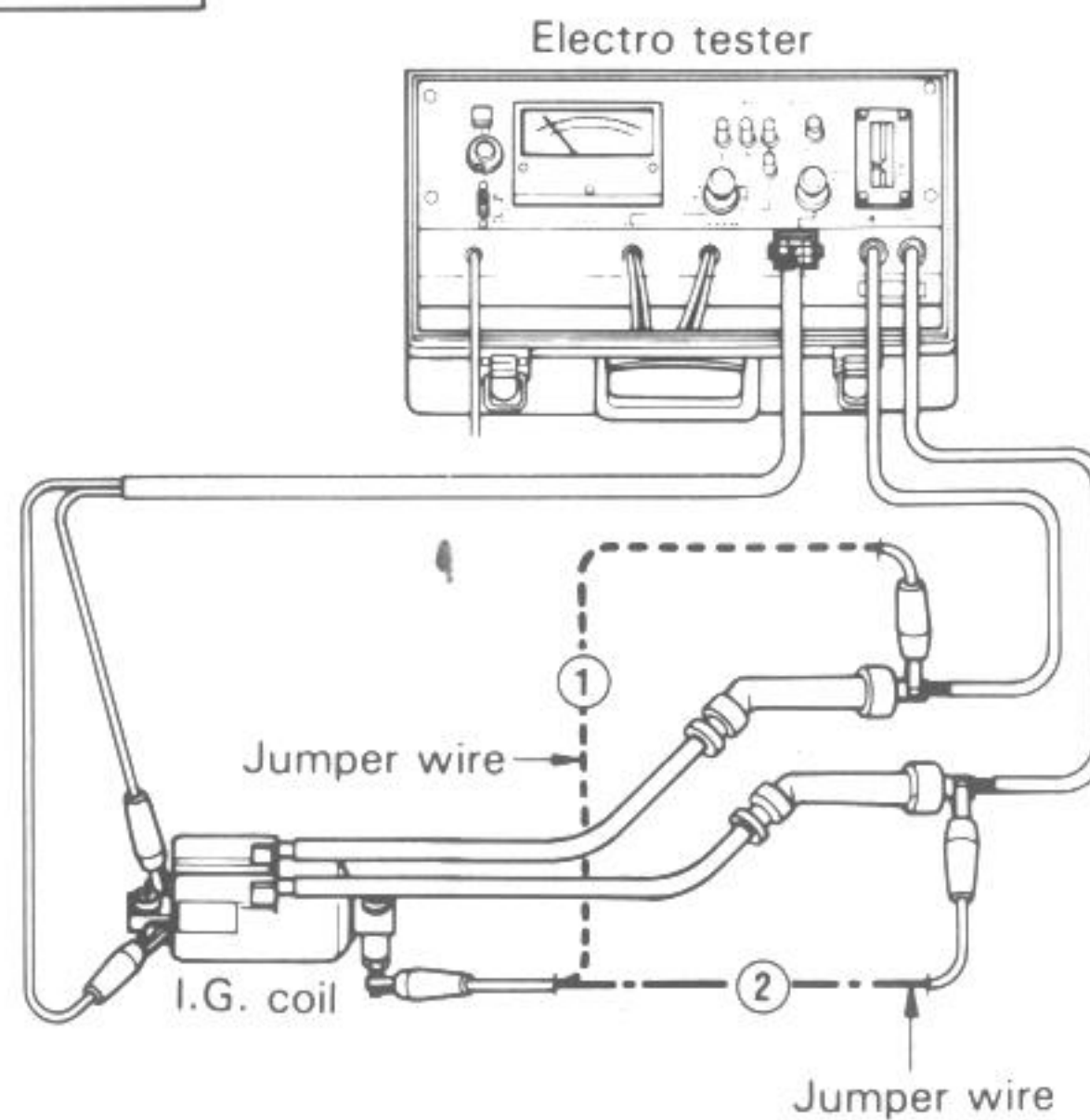

Prepared by

SUZUKI MOTOR CORPORATION

Overseas Service Department

4rd Ed. October, 1995

1st Ed. January, 1984

Manual No. : 99500-39032-01E

Printed in Japan

SUZUKI MOTOR CORPORATION

2 1 P 2