



## VDO SERIES-Z

FOR CYCLING

**Z2**  
PC LINK

INSTRUCTION MANUAL / BEDIENUNGSANLEITUNG / MANUEL D'INSTALLATION  
ET D'UTILISATION / HANDLEIDING / MANUALE D'INSTALLAZIONE E FUNZIONAMENTO  
INSTRUKCJA OBSLUGI LICZNIKA / INSTALACION Y OPERACION MANUAL

# My Settings



AGE:

WEIGHT:

MAX HEARTRATE:

LIMIT 1: LOW:

HIGH:

LIMIT 2: LOW:

HIGH:

LIMIT 3: LOW:

HIGH:

RECOVERY TIME:

RECOVERY PULSE:

BIKE 1 WEIGHT:

BIKE 2 WEIGHT:

BIKE 1 WHEELSIZE:

BIKE 2 WHEELSIZE:

BIKE 1 SERVICE INTERVALL:



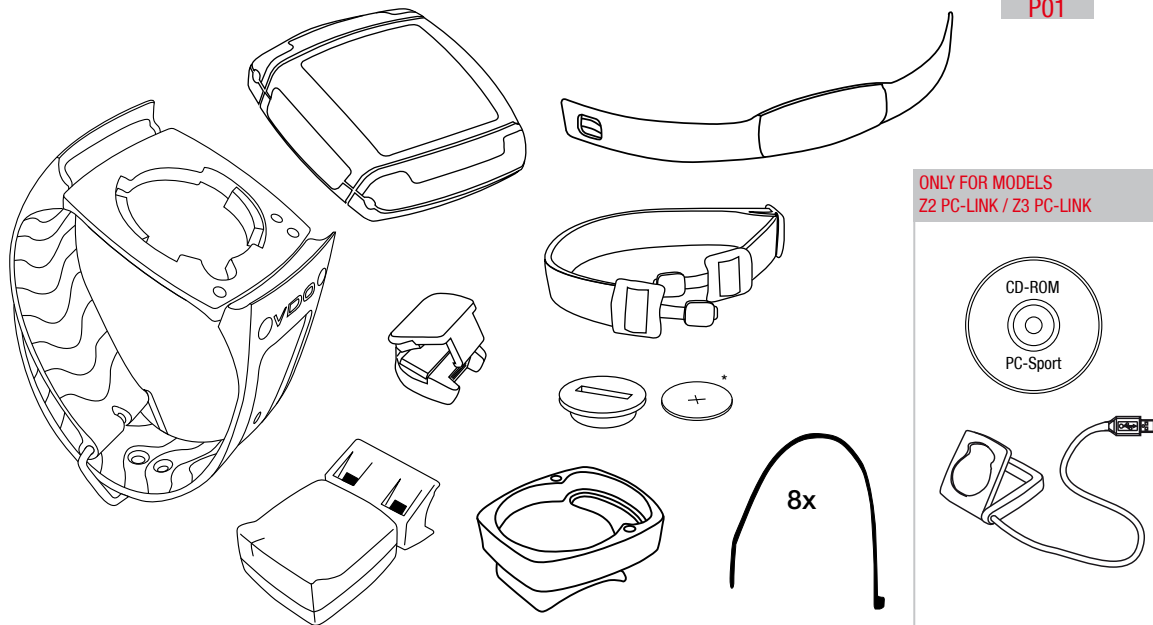

BIKE 2 SERVICE INTERVALL:

HOME ALTITUDE:

FURTHER SETTINGS:



ONLY FOR MODELS  
Z2 PC-LINK / Z3 PC-LINK

\* **Watch out:** old batteries require special disposal     
Please read instructions for end-off-life disposal treatment  

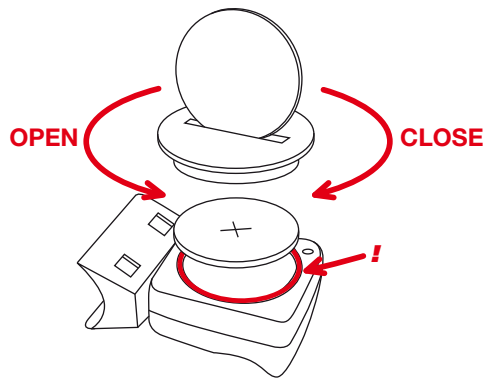
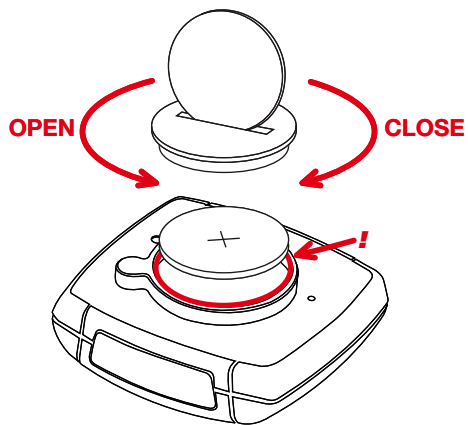

P03

ONLY FOR  
MODELS

Z2/Z2 PC-LINK

Z3/Z3 PC-LINK

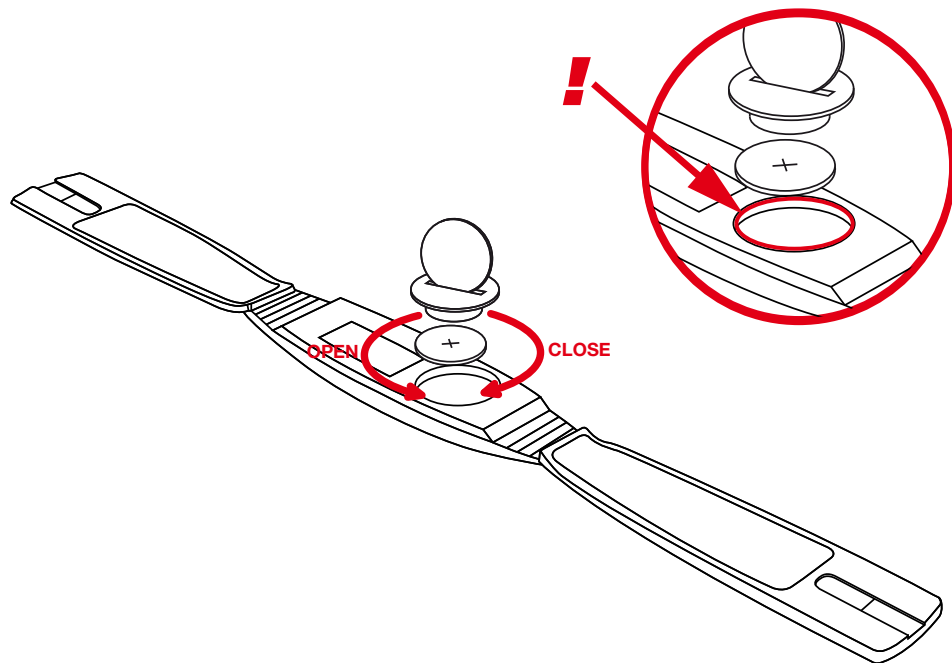

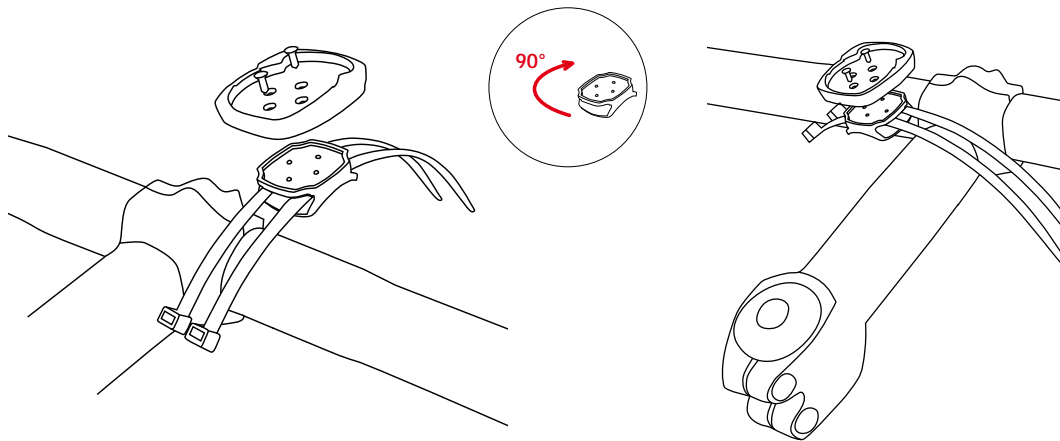

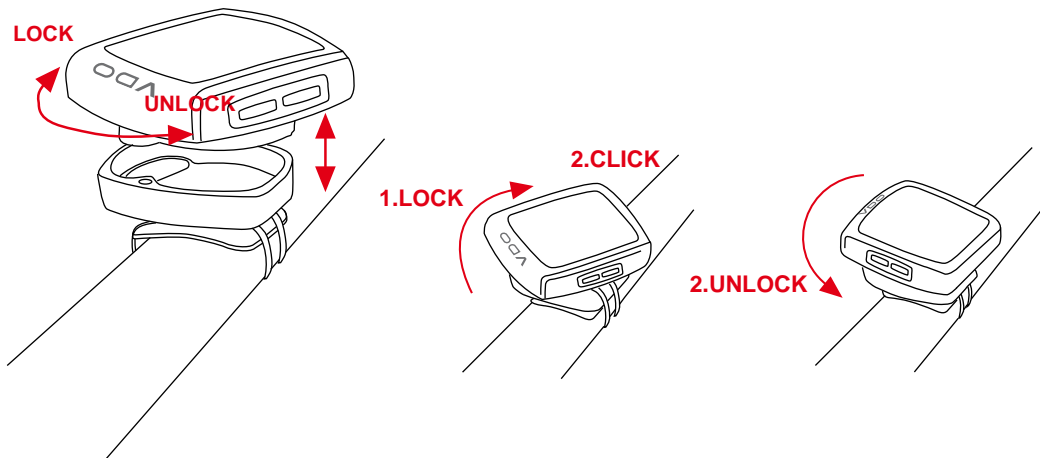

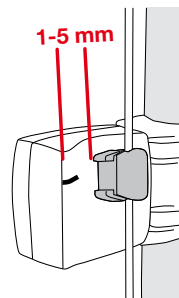
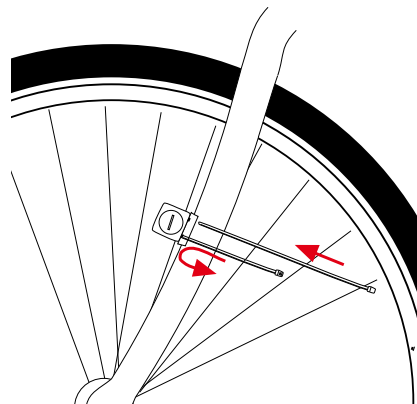
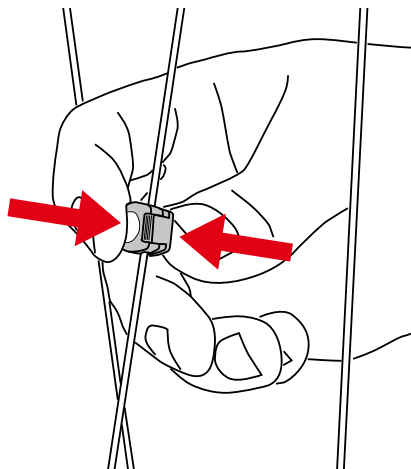

**P08**

**ONLY FOR  
MODELS**

**Z2/Z2 PC-LINK**

**Z3/Z3 PC-LINK**

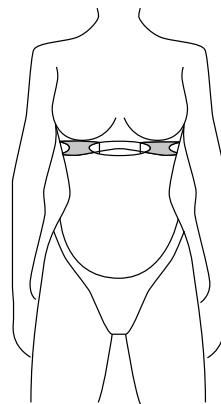
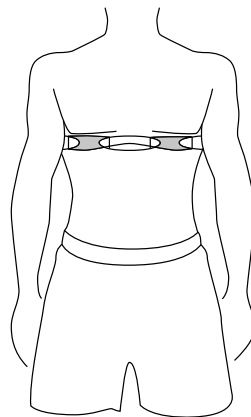
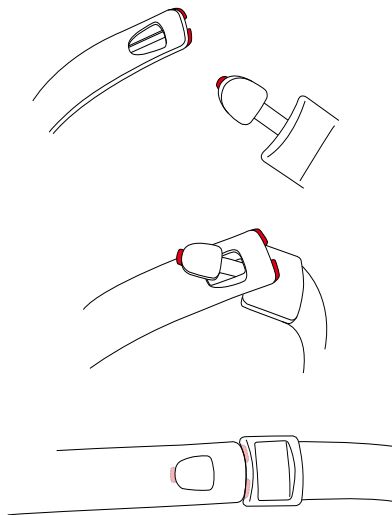

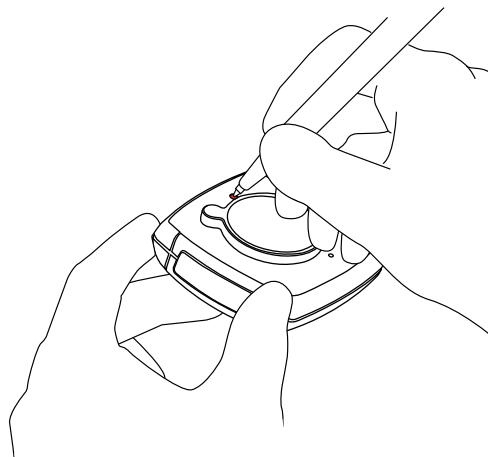
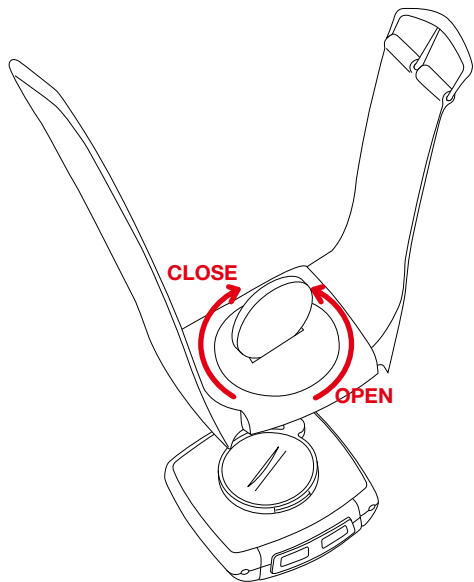

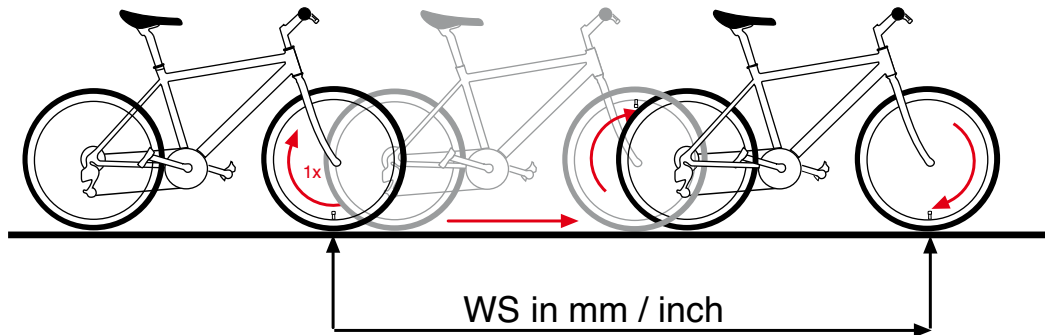

Tire size	WS in mm	KMH	WS in inch	MPH	Tire size	WS in mm	KMH	WS in inch	MPH
47-305	16x1,75	1272	50,1		20-571	26x3/4	1954	76,9	
47-406	20x1,75	1590	62,6		32-630	27x1 1/4	2199	86,6	
34-540	24x1 3/8	1948	76,7		40-622	28x1,5	2224	87,6	
47-507	24x1,75	1907	75,1		47-622	28x1,75	2268	89,3	
23-571	26x1	1973	77,7		40-635	28x1 1/2	2265	89,2	
40-559	26x1,5	2026	79,8		37-622	28x1 3/8	2205	86,8	
44-559	26x1,6	2051	80,7		18-622	700x18C	2102	82,8	
47-559	26x1,75	2055	80,9		20-622	700x20C	2114	83,2	
50-559	26x1,9	2060	81,1		23-622	700x23C	2133	84,0	
n/a	26 x 1,95	2070	81,5		25-622	700x25C	2146	84,5	
54-559	26x2,00	2075	81,7		28-622	700x28C	2149	84,6	
n/a	26 x 2,1	2080	81,9		32-622	700x32C	2174	85,6	
57-559	26x2,125	2133	84,0		37-622	700x37C	2205	86,8	
37-590	26x1 3/8	2105	82,9		40-622	700x40C	2224	87,6	

P11

ONLY FOR  
MODELS  
Z2 PC-LINK  
Z3 PC-LINK

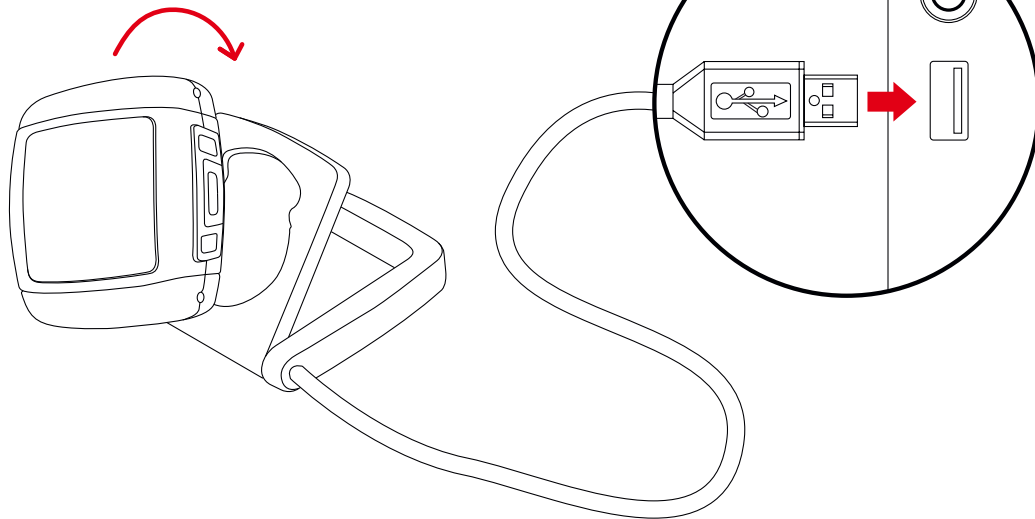

### Congratulations

With your selection of a VDO Z2 PC-Link you have opted for high-quality sports information computer. In order to fully benefit from the potential of the computer, we recommend that you carefully read this manual. It contains all operating instructions and many useful tips.

We extend our best wishes for enjoyment and satisfaction when riding with your VDO computer.

VDO Cyclecomputing Cycle Parts GmbH

### Package contents >>> P01

First, please ensure that the contents of this package are complete:

- 1 VDO computer Z2 PC-Link
- 1 VDO speed transmitter
- 1 VDO pulse-chest belt incl. elastic strap, incl. battery
- 1 battery for computer, 3 V type 2032
- 1 handlebar holder
- 1 wrist band holder
- 1 lock for the wrist band holder
- 1 spoke magnet
- 1 docking station with USB cable for data transfer to the PC
- 1 CD-ROM with analysis software for the PC
- 8 cable ties

Optional extension set:

VDO cadence transmitter

### >>> P...

Reference to the appropriate pages in the picture book. This is where the content is again presented in picture form, e.g.:

>>> P01 → P01 page 1 in the picture book

## TABLE OF CONTENTS

- 1.1. General
- 1.2. Important instructions for the digital wireless system
- 1.3. Control system - operation
  - 1.3.1. Operating mode
  - 1.3.2. Setting mode
- 1.4. The display
- 1.5. Extension options & accessories

## 2. INSTALLATION

- 2.1. Battery installation
  - 2.1.1. Battery installation - computer and speed/cadence transmitter
  - 2.1.2. Battery installation pulse-chest belt.
- 2.2. Installation - holder/computer/transmitter/magnet
- 2.3. Putting on the pulse-chest belt
- 2.4. Mounting the computer on the wrist band

## 3. INITIAL OPERATION

- 3.1. Initial operation, AC-button
- 3.2. Language selection
- 3.3. Manual pairing - INITIAL operation wireless system
  - 3.3.1. Initial operation - pulse transmitter
  - 3.3.2. Initial operation - speed transmitter
  - 3.3.3. Initial operation - cadence transmitter

## 4. GENERAL SETTINGS

- 4.1. Setting the language
- 4.2. Setting time & date
- 4.3. Setting the alarm, alarm clock

## 5. BICYCLE FUNCTION SETTINGS

- 5.1. Measuring and setting wheel size/s
- 5.2. Changing wheel size
- 5.3. Setting total kilometers
- 5.4. Bike check / service interval

## 6. PERSONAL SETTINGS IMPORTANT NOTE

The personal settings are prerequisite for calculating maximum pulse, training zones, and calorie consumption.

Ensure that you make the personal settings first so that you can fully utilize the possibilities offered by the computer.

- 6.1. Personal settings with manual max. pulse entry
- 6.2. Personal settings with automatic max. pulse calculation

## 7. PULSE FUNCTION SETTINGS

- 7.1. Automatic calculation of pulse limit values
- 7.2. Manual entry of pulse limit values
- 7.3. Selecting the training range
- 7.4. Setting the recovery measurement (pulse or time)

**8. RESET MODE**

- 8.1. Resetting trip data
- 8.2. Reset total ride time
- 8.3. Resetting the total distance meter
- 8.4. Resetting the Navigator
- 8.5. Resetting to factory settings (AC button)

**9. OPERATION MODE SELECTION**

Selecting the operation mode: Bike mode or walk mode

**10. OPERATION MODE**

- 10.1. Function overview
- 10.2. Fast pairing after interruption > 15 minutes
- 10.3. GETTING STARTED
- 10.3.0. The permanent functions in the display
- 10.3.1. to 10.3.22. Quick overview - functions/operation/reset/max. values

**11. RIDING WITH THE NAVIGATOR**

- 11.1. Selecting Navigator mode
- 11.2. Resetting the Navigator at the orientation point

**12. THE TIMING FUNCTIONS**

- 12.1. Selecting the timing function
- 12.2. Setting the timer (when selecting timer 1 or timer 2 or timer 1 + 2)
- 12.3. Setting timer 1 + 2 repeats (when selecting timer 1 + 2)
- 12.4. Setting the countdown (when selecting countdown timer)
- 12.5. Lap timer
- 12.6. Stopwatch

**13. TRAINING WITH THE PULSE FUNCTIONS**

- 13.1. Training with the stopwatch
- 13.2. Training with timer 1 / timer 2 / timer 1+2
- 13.3. Training with the countdown timer
- 13.4. Training with the lap timer

**14. THE DATA RECORDING FUNCTION & TRANSFER OF DATA TO THE PC**

- 14.1. Starting/stopping data recording
- 14.2. Transferring data to your PC
- 14.3. Selection of the recording interval

**15. SLEEP MODE****16. TROUBLESHOOTING****17. GUARANTEE CONDITIONS****18. TECHNICAL SPECIFICATIONS**

## 1.1. GENERAL

### 1.2 IMPORTANT INSTRUCTIONS FOR THE DIGITAL WIRELESS SYSTEM

Your VDO Z2 PC-Link works entirely without cable; it works with triple digital wireless transmission based on well-established ANT+Sport® wireless protocol. The ANT+Sport® wireless protocol has already been successfully implemented by manufacturers such as Garmin, Specialized, and Suunto. Speed signals, cadence signals (optional), as well as heart rate data are transmitted to the respective receiver (computer) as digital and coded signals. Signal coding ensures that only the data of your own pulse, speed, and cadence (optional) transmitters are processed (this is advantageous when riding in a group).

The ANT+Sport digital technology is significantly more reliable than the technology of older analog systems. The ANT+Sport technology uses standard industrial wireless components, and it can best be compared to the technology used in modern WLAN networks. The connection between transmitter and receiver is more stable, and subject to significantly less frequent malfunction, and it is virtually completely safeguarded from data loss.

The speed transmitter has a memory component that buffers data every 65 sec. Thus no data is lost if there is a malfunction lasting for this duration. After the malfunction this data will be resent to the computer. Subsequently the following data will be updated:

Daily distance  
Ride time  
Average speed  
Navigator  
Total distance  
Total ride time

After a malfunction the data can change suddenly = updating the computer. Initial operation of a completely digital system requires somewhat more care than does initial operation of conventional analog systems. The first time batteries are inserted, or after a battery change, the transmitter automatically generates a new code. The computer has to learn this code. To do this you must execute a DIG CONNECT SET. Strictly follow the instructions in chapter 3.3 to do this.

**ATTENTION:** Your VDO computer is not suitable for use on motorcycles.

### 1.3 CONTROL SYSTEM - OPERATION

The control system of your computer is based on dual assignment of the 4 main buttons. In this regard the device distinguishes between operation mode and setting mode.

1.3.1. OPERATION MODE - use this mode to display all information  
 Button assignment is shown on the housing.

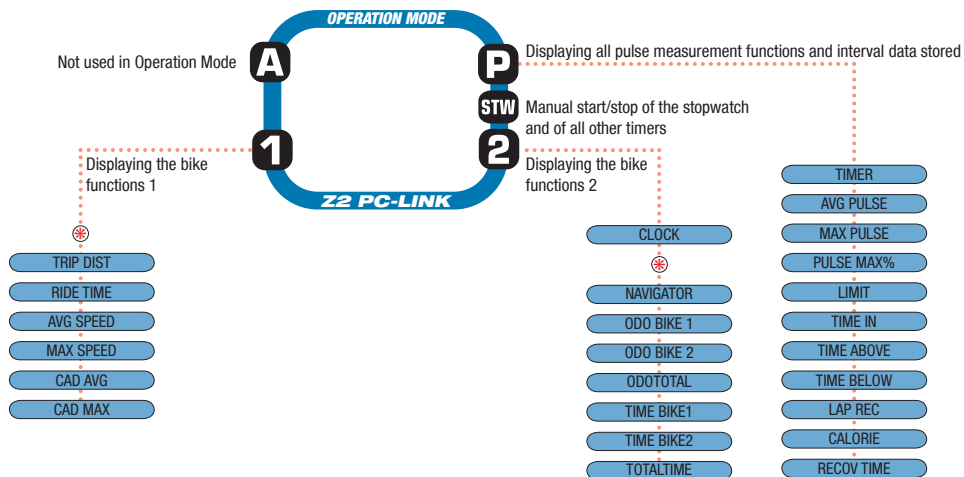

\* Not in walk mode !

1.3.2. SETTING MODE - use this mode to make all settings. The assignment of buttons is on the buttons

To go to setting mode:

Press button **I** for 3 seconds

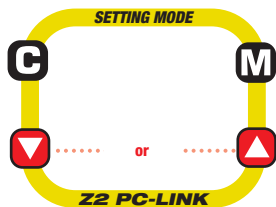

LANGUAGE SELECT	.....	Chap. 4.1.
NAVIGATOR SET	.....	Chap. 11.1.
WHEELSIZE SET	.....	Chap. 5.1.
WHEELSIZE CHANGE	.....	Chap. 5.2.
CLOCK SET	.....	Chap. 4.2.
ALARM SET	.....	Chap. 4.3.
TIMER SETTINGS	.....	Chap. 12.1.
ODOMETER SET	.....	Chap. 5.3.
PULSE LIMIT SETTINGS	.....	Chap. 7.1.
RECOVERY SET	.....	Chap. 7.4.
PERSON DATA SET	.....	Chap. 6.1.
OP MODE SELECT	.....	Chap. 9.
BIKE CHECK SET	.....	Chap. 5.4.
DIG-CONNECT SET	.....	Chap. 3.3.
PC LINK SELECT	.....	Chap. 14.1.

- G** (Once) = last step, or back one menu level  
(Hold) = return to start menu
- M** Select/confirm displayed option  
In the highest menu level select the next menu level  
Page down within the menu level

- ▼** In SET mode (number flashes): Reduce number  
Page up within the menu level
- ▲** In SET mode (number flashes): Increase number  
After subsequent confirmation of a setting the computer automatically returns to operation mode.

#### 1.4. THE DISPLAY

The display of your VDO computer is comprised of three large areas. The following information is displayed in operation mode:

\*If the computer is worn as a sport watch then the temperature can be falsified by body warmth.

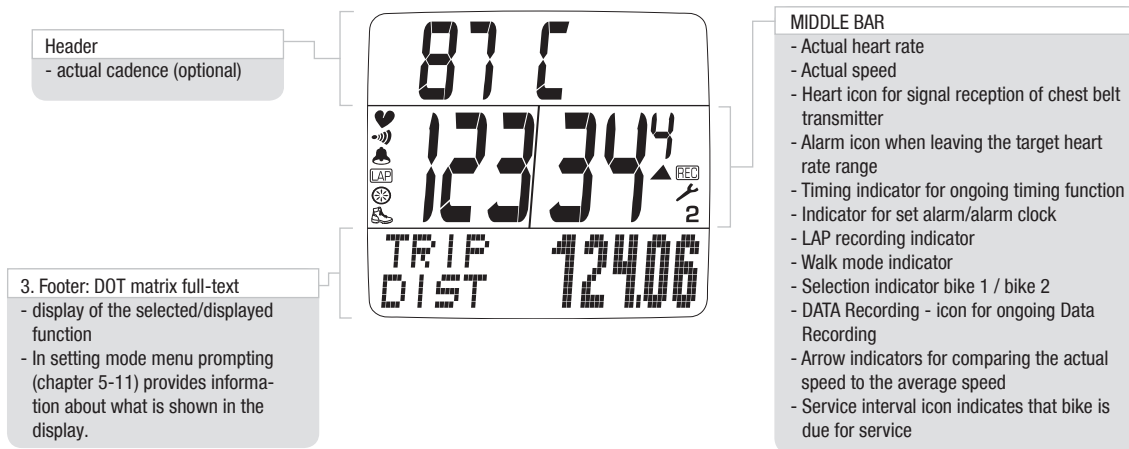

## 1.5. EXTENSION OPTIONS & ACCESSORIES

Extension option: You have the possibility of extending your computer with the cadence extension set

In this case the following cadence functions are available to you:

Actual cadence

Average cadence

Maximum cadence



In addition you can also get the following original VDO replacement parts from your dealer

Designation	article number
Universal handlebar holder - wireless	art. no. 5503
Magnet S/M for speed impulses	art. no. 4410
Magnet L/XL for speed impulse	art. no. 4412
Cadence magnet	art. no. 4411
Speed transmitter	art. no. 6602
Pulse transmitter (incl. elastic chest belt)	art. no. 6605
Elastic chest belt for pulse transmitter article	art. no. 6606

Replacement docking station	art. no. 6609
Cadence kit	art. no. 6603
Wrist band	art. no. 6607
Wrist band twist-click lock	art. no. 6608
Universal mount kit	art. no. 6601

When purchasing look for the VDO Cyclecomputing original equipment logo. Only products bearing this logo are authorized by VDO Cyclecomputing for use with your computer.

## 2. INSTALLATION

### 2.1. BATTERY INSTALLATION

#### 2.1.1 BATTERY INSTALLATION - COMPUTER AND SPEED/CADENCE TRANSMITTER >>> P02

- step 1 Insert the battery into the computer/transmitter housing with the + pole up.
- step 2 Ensure that the battery is not tilted.
- step 3 Ensure that the rubber seal lies smoothly on the lid of the battery compartment.
- step 4 Insert the battery compartment lid into the opening and use a coin to firmly turn the battery door to right until the stop (approximately 1/3 turn)

TIP for changing batteries: VDO recommends changing the batteries yearly to avoid undesired data loss. Thus strictly ensure that you note the entered wheel sizes as well as the previous ridden kilometers for bike 1 & bike 2, as well as the total altitude difference for bike 1, bike

2, and the altitude difference walked. Reprogram this information after inserting the new batteries.

### 2.1.2 BATTERY INSTALLATION PULSE-CHEST BELT >>> P03

Your VDO is shipped with the battery installed in the pulse-chest belt.

Proceed as follows when later inserting a replacement battery:

- step 1 Insert the battery into the chest-belt housing with the +pole up.
- step 2 Ensure that the battery is not tilted.
- step 3 Strictly ensure that the rubber seal lies smoothly on the battery compartment lid.
- step 4 Insert the battery compartment lid into the opening and use a coin to firmly turn the battery door to right until the stop (approximately 1/3 turn)

## 2.2. INSTALLATION - HOLDER/COMPUTER/TRANSMITTER/MAGNET

a. Holder >>> P04/05: Your VDO computer is shipped with a universal handlebar holder.

- step 1 You can mount the holder either on the handlebar or the stem. If you are installing the holder on the handlebar decide whether you want it on the right side or the left side. If installing on the stem, loosen the screws in the holder and turn the foot of the holder to stem installation. Then screw the foot firmly onto the holder again.
- step 2 Route the cable ties through the provided eyes of the holder foot and pull both of them tight.

### b. Computer >>> P06

The VDO twist-click system securely connects the computer to the handlebar holder.

- step 1 Insert the computer, turned to the left approximately 45 degrees (10 o'clock position) into the holder.
- step 2 Twist the computer to the right until it audibly engages (clicks) in the holder system (12 o'clock position).
- step 3 To remove the computer turn it to the left (do not press or pull).

### c. Speed transmitter and magnet >>> P07

Mount the transmitter on the same side of the handlebar that the computer is mounted on. If you have installed the holder on the stem then we recommend mounting the transmitter on the left side.

- step 1 Loosely fasten the transmitter on the fork with cable ties (do not tighten).
- step 2 Place the spoke magnet on a spoke
- step 3 Align the spoke magnet to the transmitter marking with a clearance of approximately 3 mm and click it together.
- step 4 Align transmitter and magnet relative to each other and tighten the cable tie on the transmitter.

Please pay attention to the maximum distances:

- Maximum transmitter-computer distance = 120 cm
- Transmitter-magnet distance: 3 mm to a maximum of 10 mm

## 2.3. PUTTING ON THE PULSE-CHEST BELT >>> P08

- step 1 First connect the one side of the pulse transmitter with the elastic strap, as shown. Press the ends of the pulse-chest belt into the plastic holder of the elastic strap
- step 2 Place the pulse transmitter just below your chest and guide the elastic strap over your back to the other end of the pulse transmitter
- step 3 Connect the second end of the plastic strap to the pulse transmitter
- step 4 Use the size adjustment of the elastic strap to adjust the chest belt to your chest size

Please note:

- Do not adjust the chest belt too loose; if it is too loose it can slip if there are jolts (e.g. when walking)
- When putting on the chest belt moisten the electrodes so that trouble-free function is also ensured when starting exercise, before contact is established through sweat.
- Range of the pulse-chest belt transmitter = 0.90 m

## 2.4. MOUNTING THE COMPUTER ON THE WRIST BAND >>> P09

- step 1 Insert the computer into the opened wrist band
- step 2 Insert the lock into the wrist band holder from below
- step 3 Turn the lock with a coin to tighten it

**ATTENTION:** Never use a screwdriver to operate the lock. This could damage the lock (if the lock should be damaged then you can get the lock as original replacement part)

## 3. INITIAL OPERATION

### 3.1. INITIAL OPERATION, AC-BUTTON >>> P09-2

After inserting the batteries we recommend that you first reset the device to factory settings to ensure that no residual data from the quality control process remains in the computer. This puts the computer into an assured start mode.

- Press the AC button for approximately 2 seconds with a sharp object, such as a pencil

### 3.2. LANGUAGE SELECTION

- 3sec. **1** Setting mode LANGUAGE SELECT
- step 2 **M** Confirm LANGUAGE SELECT with M
- step 3 **▼▲** Press the up or down button until the desired language appears
- step 4 **M** Confirm your language selection with M

### 3.3. MANUAL PAIRING - INITIAL OPERATION WIRELESS SYSTEM

For initial operation of the digital wireless system manual pairing must ALWAYS be executed. Manual pairing ensures that the computer learns the coding of the transmitter you are using.

- step 1 Insert the computer into the twist-click holder
- step 2 Ensure that there are no ANT+Sport digital transmitters other than the transmitter you are using within a 5-meter area around the computer

Your computer will randomly select one of 128,000 codes. This ensures that signals of other transmitters are not received or processed (e.g. when riding in a group). If dashes are shown in the display, in spite of pairing, you must repeat the manual pairing process. In doing so

ensure that the electrodes of the pulse transmitter belt are wet, or that the distance between the magnets and the speed/cadence transmitter is not greater than 5 mm.

ATTENTION: Your computer can save the codes of up to 5 transmitters

1. Speed transmitter of bike 1
2. Speed transmitter of bike 2
3. Cadence transmitter of bike 1 (optional)
4. Cadence transmitter of bike 2 (optional)
5. Pulse transmitter

### 3.3.1. INITIAL OPERATION - PULSE TRANSMITTER

Put the pulse transmitter belt on and moisten the electrodes (chapter 2.3)

- 3sec. **1** Setting mode LANGUAGE SELECT
- ▼ ▲** Select DIG CONNECT SET
  - M** Display DIG CONNECT
  - ▼ ▲** Select PULSE SEARCH
  - M** PULSE PAIRING

PAIR DONE appears in the display after several seconds if the pulse transmitter was found. Automatic return to the TRIP DIST menu. If the pulse transmitter was not found PULSE REPEAT appears. Use **M** to repeat the pairing process for the pulse transmitter. For troubleshooting see chapter 16.

### 3.3.2. INITIAL OPERATION - SPEED TRANSMITTER

- 3sec. **1** Setting mode LANGUAGE SELECT
- ▼ ▲** Select DIG CONNECT SET
  - M** Display DIG CONNECT

- ▼ ▲** Select SPEED SEARCH

- M** SPEED PAIRING

Now turn the front wheel (both magnet and transmitter must be already mounted)

PAIR DONE appears in the display after several seconds if the speed transmitter was found. Automatic return to the TRIP DIST menu

SPEED REPEAT appears if the speed transmitter was not found.

Use **M** to repeat the pairing process for the speed transmitter.

For troubleshooting see chapter 16.

### 3.3.3. INITIAL OPERATION - CADENCE TRANSMITTER (OPTIONAL EXTENSION see chapter 1.5)

- 3sec. **1** Setting mode LANGUAGE SELECT
- ▼ ▲** Select DIG CONNECT SET
  - M** Display DIG CONNECT
  - ▼ ▲** Select CADENCE SEARCH
  - M** CADENCE PAIRING

Now turn the crank (magnet and transmitter must be already mounted)

PAIR DONE appears in the display after several seconds if the cadence transmitter was found.

Automatic return to the TRIP DIST menu

If the cadence transmitter was not found CADENCE REPEAT will be displayed. With **M** repeat the pairing for the cadence transmitter

For troubleshooting see chapter 16.

IMPORTANT NOTE / Re-open of transmitter search for the receive channel after interruption

If no signal is received from an already paired transmitter after 15 minutes (for example riding without chest belt for Z2 and Z3, also PC-LINK models), the receive channel will be closed for this transmitter. In this case your VDO computer will show dashes for the respective function in the display. To re-open all receive channels press the **1** and **A** buttons at the same time: Now your VDO computer will again receive all previously paired transmitters that are in range.

Short  
PAIRING  
Cut

## 4. GENERAL SETTINGS

### 4.1. SETTING THE LANGUAGE

- 3sec. **1** Setting mode LANGUAGE SELECT  
**M** LANGUAGE SELECT  
**▼▲** Select „LANGUAGE ENGLISH“  
**M** Automatic return to TRIP DIST

Language selection done.

### 4.2. SETTING TIME & DATE

- 3 sec. **1** Setting mode LANGUAGE SELECT  
**▼▲** CLOCK SET  
**M** SET HOUR ?CONTINUE?  
**▼▲** Setting hours  
**M** SET MINUTES ?CONTINUE?  
**▼▲** Setting minutes  
**M** SET YEAR ?CONTINUE?  
**▼▲** Setting the year

- M** SET MONTH ?CONTINUE?  
**▼▲** Setting the month  
**M** SET DAY ?CONTINUE?  
**▼▲** Setting the day  
**M** CLOCK ?SET OK?  
**M** CLOCK SET DONE

Automatic return to CLOCK.

### 4.3. SETTING THE ALARM, ALARM CLOCK

- 3 sec. **1** Setting mode LANGUAGE SELECT  
**▼▲** ALARM SET  
**M** ALARM ON or ALARM OFF ( **▼** to switch on)

When the alarm clock is switched off setting mode ends automatically by **M**.

- M** SET HOUR ?CONTINUE?  
**▼▲** Selecting the hours value  
**M** „SET MINUTES ?CONTINUE?“  
**▼▲** Selecting the minutes value  
**M** ALARM ?SET OK?  
**M** ALARM SET DONE!

Automatic return to the operation mode for CLOCK. Setting the alarm clock done. The alarm clock icon is now shown in the display (center bar left).

## 5. BICYCLE FUNCTION SETTINGS

### 5.1. MEASURING AND SETTING WHEEL SIZE/S

In order for your VDO computer to measure correctly you must first measure the circumference of your wheel. If this value is set incorrectly then all values calculated on the basis of this value, such as speed, trip,

etc. will be wrong. To use your VDO computer on two different bikes e.g. mountain bike and road bike you can enter two different wheel sizes. Measuring the wheel circumference:

- step 1 Align the valve of the front wheel so that it is precisely vertical to the ground
- step 2 Mark this point on the ground with a line (use chalk for example)
- step 3 Push the bike one wheel rotation forward until the valve is again vertical to the ground.
- step 4 Mark this point on the ground as well.
- step 5 Measure the distance between the two marks. The result is your wheel circumference (=roll circumference).
- step 6 Enter the wheel circumference as described below into your VDO computer.

ATTENTION: If you have selected KMH display then you must enter the wheel circumference in mm. If you have selected MPH display then enter the wheel circumference in inches. The values listed in table >>> P10 are approximate values. These values deviate depending on brand of tire, tire height and tire tread.

Setting wheelsize:

- 3 sec. **1** Setting mode LANGUAGE SELECT
- ▼▲** WHEELSIZE SET
- M** WHEELSIZE KMH-DISPLAY or WHEELSIZE MPH-DISPLAY (**▼** to change to mph)
- M** WHEELSIZE 1 ... SET SIZE ?CONTINUE?
- ▼▲** Set wheel size 1 in mm (keep button depressed for fast run-through)

**M** WHEELSIZE 1 ?SET OK?

**M** WHEELSIZE 1 SET DONE

Automatic change to

**▼▲** Set wheel size 2 in mm (keep button depressed for fast run-through)

**M** WHEELSIZE 2 ?SET OK?

**M** WHEELSIZE 2 SET DONE

Automatic return to operation mode for TRIP DIST. If you do not want to set wheel size 2 then hold **C** to return to TRIP DIST operation mode.

Attention: Factory settings for bike 1 = 2155 mm and for bike 2 = 2000 mm. If you do not enter wheel sizes the computer will work with the factory settings. The values measured in this manner for speed, distance, etc. can deviate from the actual values.

## 5.2. CHANGING THE WHEEL SIZE

With wheel size you change the computer from bike 1 (e.g. road bike) to bike 2 (e.g. mountain bike). The computer now works with the settings for bike 2.

- 3 sec. **1** Setting mode LANGUAGE SELECT
- ▼▲** WHEELSIZE CHANGE
- M**
- ▼▲** WHEELSIZE 1 or WHEELSIZE 2 ?SET OK?
- M**
- ▼▲** Changing the wheel size
- M** WHEELSIZE SET DONE
- Automatic return to TRIP DIST

## Wheel size set done

Display of the actual wheel size in the center bar of the display, right bottom (1 or 2)

## 5.3. SETTING TOTAL KILOMETERS

You can program the total distances into your VDO computer that get lost when changing batteries or that you have previously counted with a different device. This function is available for both wheel sizes (both bikes).

### Setting total KM 1 or 2

- 3 sec. **1** Setting mode LANGUAGE SELECT  
**▼▲** ODOMETER SET  
**M** ODO BIKE 1 SET or **▲** ODO BIKE 2 SET  
**M** ODO BIKE 1/2 NEXT DIGIT?  
**▼▲** Set last digit (keep button depressed for fast run-through)  
**M** ODO BIKE 1/2 NEXT DIGIT?  
**▼▲** Set digit (keep button depressed for long run-through) ... repeat for all digits from back to front  
**M** ODO BIKE 1/2 ?SET OK?  
**▼▲** Set first digit (keep button depressed for fast run-through)  
**M** ODO BIKE 1/2 SET DONE

Automatic return to operation mode for ODO BIKE 1/2 menu. Set ODO BIKE 1/2 done.

## 5.4. BIKE CHECK / SERVICE INTERVAL

Your VDO Computer allows you to set the service interval to any interval for both of your bikes independently. The service check reminds you to have your bicycle serviced, like the service indicator in your car.

Set bike check bike 1 or bike 2

- 3 sec. **1** Setting mode LANGUAGE SELECT  
**▼▲** BIKE CHECK SET  
**M** BIKE CHECK ON or BIKE CHECK OFF (**▼** to switch off the bike check)  
**M** „BIKE 1 SET or BIKE 2 SET  
**▼▲** Set service interval in KM or m (keep button depressed for fast run-through)  
**M** BIKE 1/2 ?SET OK?  
**M** BIKE 1/2 SET DONE

Automatic return to operation mode for TRIP DIST

Bike check set done

If BIKE CHECK is shown in the display then you should either perform the recommended bike check yourself or have your bike checked by your dealer. Press any button. The BIKE CHECK text will disappear. After another 50 km the service interval icon (screw driver) will disappear.

## 6. PERSONAL SETTINGS (YOUR DATA)

**IMPORTANT NOTE:** The personal settings are the prerequisite for calculating maximum pulse, training zones, and calorie consumption. Ensure that you make the personal settings first so that you can fully utilize the possibilities offered by the computer. Your personal maximum pulse is an important value. You can enter this value into your VDO computer

if you know it from earlier measurements (e.g. at the doctor's office or from a performance test). If you do not know it then you can select automatic calculation of your maximum pulse.

**WARNING:** Automatic calculation is based on average values for people that are athletic and healthy. The actual value can deviate from this average value for people who have not been athletically active for some time, or who after illness, are going through a rehabilitation program. Strictly ensure that you speak with your doctor before starting to train, so that he can confirm that training would not be associated with any adverse effects.

### 6.1. PERSONAL SETTINGS WITH MANUAL MAX. PULSE ENTRY

**IMPORTANT:** A wrong entry can have adverse effects on your health. Tables providing general information cannot reliably reflect your specific training status. Strictly ensure that you speak with your doctor before entering your max. pulse manually.

- 3 sec. **1** Setting mode LANGUAGE SELECT
- ▼▲** PERSON DATA SET
  - M** SET AGE ?CONTINUE?
  - ▼▲** Setting age
  - M** SET WEIGHT ?CONTINUE?
  - ▼▲** Setting weight
  - M** SET SEX ?CONTINUE?
  - ▼▲** Setting sex (M = male, F = female)
  - M** SET P MAX MANUAL (**▲** to go to manual max. pulse calculation)
  - M** PULSE MAX ?SET OK?

- ▼▲** Setting the maximum pulse
- M** PERSON DATA ?SET OK?
- M** PERSON DATA SET DONE

Automatic return to operation mode for the selected timer. Set P MAX MANUAL done.

### 6.2. PERSONAL SETTINGS WITH AUTOMATIC MAX. PULSE CALCULATION

**IMPORTANT:** Automatic max. pulse calculation is based on tables showing general information that cannot reliably reflect your specific training status. Before you start training strictly ensure that you speak with your doctor.

- 3 sec. **1** Setting mode LANGUAGE SELECT
- ▼▲** PERSON DATA SET
  - M** SET AGE ?CONTINUE?
  - ▼▲** Setting age
  - M** SET WEIGHT ?CONTINUE?
  - ▼▲** Setting weight
  - M** SET SEX ?CONTINUE?
  - ▼▲** Setting sex (M = male, F = female)
  - M** SET P MAX MANUAL (go to autom.)
  - ▼▲** SET P MAX AUTOCALC
  - M** Auto VALUE will be displayed for 2 seconds  
PULSE MAX CALC DONE
  - M** PERSON DATA ?SET OK?
  - M** PERSON DATA SET DONE

Automatic return to operation mode for the selected timer. Set HF max manually done.

## 7. PULSE FUNCTION SETTINGS

The pulse functions of your VDO computer are based on the specification of three training programs each with 3 training ranges.

Limit 1 = program 1: for recovery training (high 70%, low 50% of max. pulse)

Limit 2 = program 2: program for endurance training (high 80%, low 70% of max. pulse)

Limit 3 = program 3: Training program for development ranges (high 95%, low 80% of max. pulse)

For automatic calculation of the training programs ensure that values are calculated that correspond to your personal settings (chapter 6). Also pay attention to the warning in chapter 6. All information concerning use and starting of pulse recording is provided in chapter 13.1-13.4.

### 7.1. AUTOMATIC CALCULATION OF PULSE LIMIT VALUES

Automatic calculation of pulse limit values functions only after entry of the personal data (chapter 6).

Your computer automatically assigns the following limit values to the three training programs

Limit 1 = HIGH 70%, LOW 50% of maximum pulse

Limit 2 = HIGH 80%, LOW 70% of maximum pulse

Limit 3 = HIGH 95%, LOW 80% of maximum pulse

3 sec. **1** Setting mode LANGUAGE SELECT

**▼▲** PULSE LIMIT SETTINGS

**M** PULSE LIMIT ?SET?

**M** PULSE LIMIT AUTOCALC

- M** AUTO LIMIT 1 HIGH...LOW  
Shows AUTO LIMIT 1 for 3 sec., go to AUTO LIMIT 2  
AUTO LIMIT 2 HIGH...LOW  
Shows AUTO LIMIT 2 for 3 sec., go to AUTO LIMIT 3  
AUTO LIMIT 3 HIGH...LOW  
Shows AUTO LIMIT 3 for 3 sec.

Automatic return to operation mode for the selected timer.

### 7.2. MANUAL ENTRY OF PULSE LIMIT VALUES

- 3 sec. **1** Setting mode LANGUAGE SELECT
- ▼▲** PULSE LIMIT SETTINGS
- M** PULSE LIMIT ?SET?
- M** PULSE LIMIT AUTOCALC
- ▼** PULSE LIMIT MANUAL SET
- M** PULSE LIMIT 1 ?SET?
- ▼** Select LIMIT 1/LIMIT 2/LIMIT 3
- M** SET HIGH 1 ?CONTINUE?
- ▼▲** Set high limit training range 1/2/3
- M** SET LOW 1 ?CONTINUE?
- ▼▲** Set low limit training range 1/2/3
- M** LIMIT x ?SET OK? (x = selected training range 1, 2, or 3)
- M** LIMIT x SET DONE (x = selected training range 1, 2, or 3)

Automatic return to the selected TIMER.

### 7.3. SELECT TRAINING PROGRAM

- 3 sec. **1** Setting mode LANGUAGE SELECT  
**▼▲** PULSE LIMIT SETTINGS  
**M** PULSE LIMIT ?SET?  
**▼** PULSE LIMIT ?SELECT?  
**M** LIMIT 1 ?SELECT? or **▼** LIMIT 2 ?SELECT? or **▼** LIMIT 3 ?SELECT?  
**M** LIMIT 1/2/3 SET DONE

Automatic return to operation mode for the selected timer. The selected training program LIMIT 1 or LIMIT 2 or LIMIT 3 is displayed in the pulse functions **P**. The high and low limits set for the selected program will also be displayed.

### 7.4. SET RECOVERY PULSE MEASUREMENT

With your VDO computer you can select the following presets for the recovery pulse measurement.

1. Recovery time: Pulse reduction within the set recovery time.
2. Recovery pulse: Duration until reaching the set recovery pulse.

#### a. Setting the recovery time

- 3 sec. **1** Setting mode LANGUAGE SELECT  
**▼▲** RECOVERY SET  
**M** RECOV TIME SET  
**▼▲** Set the recovery time in 30 second increments  
**M** RECOV TIME ?SET OK?  
**M** RECOV TIME SET DONE

Automatic return to the operation mode for RECOV TIME  
 Recovery time set done

#### b. Setting the recovery pulse

- 3 sec. **1** Setting mode LANGUAGE SELECT  
**▼▲** RECOVERY SET  
**M** RECOV TIME SET  
**▼** RECOV PULSE SET  
**▼▲** Setting the recovery pulse  
**M** RECOV PULSE ?SET OK?  
**M** RECOV PULSE SET DONE

Automatic return to the operation mode for RECOV PULSE  
 Recovery pulse set done

**IMPORTANT FOR THE CHANGE:** In operation mode the last setting made of the settings cited above is always displayed. To change, in the settings menu confirm the desired settings as specified above.

### 3. MEASURING THE RECOVERY PULSE/RECOVERY TIME

In the operating mode select RECOVPULSE or RECOVTIME with the **P** button. To start the measurement press the buttons **1+2** at the same time. After the set recovery time elapses or after reaching the set recovery pulse the measurement will end automatically. The recovery time/recovery pulse will be displayed in the third display line.



## 8. RESET MODE

In reset mode of your VDO computer you reset the saved ride data of the bicycle computer. You can also reset the computer to the factory settings

## 8.1 TRIP DATA

ATTENTION: When resetting the trip data the following day trip data will be deleted:

- Daily distance
- Trip ride time
- Average speed
- Maximum speed

If the cadence option is mounted then the cadence data will also be reset.

- Average cadence
- Maximum cadence

3 sec. **[2]** TRIP DATA ?RESET?  
**[M]** TRIP DATA ?RESET? <<?RESET?>> flashing  
**[M]** TRIP DATA RESET DONE

Automatic return to operation mode for TRIP DIST

## 8.2 RESET TOTAL RIDE TIME

ATTENTION: When resetting total ride time the following data is deleted:

- Total ride time
- Total ride time bike 1
- Total ride time bike 2

3 sec. **[2]** TRIP DATA ?RESET?  
**[V] [▲]** TOTAL TIME ?RESET?  
**[M]** TOTAL TIME ?RESET? <<?RESET?>> flashing  
**[M]** TOTAL TIME RESET DONE?

Automatic return to the operation mode for TOTAL TIME

Reset total time done

## 8.3. RESETTING THE TOTAL DISTANCE METER

ATTENTION: When resetting the total distance the following data is deleted:

- Total distance
- Total distance bike 1
- Total distance bike 2

3 sec. **[2]** TRIP DATA ?RESET?  
**[V] [▲]** ODOTOTAL ?RESET?  
**[M]** ODOTOTAL ?RESET? <<?RESET?>> flashing  
**[M]** ODOTOTAL RESET DONE

Automatic return to the operation mode for ODOTOTAL

Odototal reset done

## 8.4. RESETTING THE NAVIGATOR

Please see the detailed description of Navigator functions in chapter 11.1.-11.2. There you will learn more about use of this reset

3 sec. **[2]** TRIP DATA ?RESET?  
**[V] [▲]** NAVIGATOR ?RESET?  
**[M]** NAVIGATOR ?RESET? <<?RESET?>> flashes  
**[M]** NAVIGATOR RESET DONE

Automatic return to the operation mode for NAVIGATOR

Navigator reset done

## 8.5. RESETTING TO FACTORY SETTINGS

WARNING: When resetting to factory settings all ride data and all computer settings will be reset, including the personal data. Only perform this reset if a software malfunction occurs or if your computer can no longer be operated.

- step 1 Use a sharp pencil  
 step 2 Press the AC button on the back of the computer for 2 sec  
 Reset to factory settings done.

## 9. OPERATION MODE SELECTION

Your VDO computer uses different measuring and analysis programs for different sport types. Certain functions are not available depending on the selected mode. For this reason you must select one of the following modes prior to starting your exercise:

- Cycle mode 
- Walk mode  (also for jogging, running, Nordic walking, inline skating)

Select operation mode:

- 3 sec. **1** Setting mode LANGUAGE SELECT  
**▼▲** OP MODE SELECT  
**M** CYCLE MODE ?SET OK?  
**▼** to change to WALK MODE ?SET OK?  
**M** Automatic return to the operation mode for TRIP DIST  
 (in cycle mode), or ALTI UP (in walk mode)

## 10. OPERATION MODE

10.1. An overview of mode functions is provided in section 1.3.1.

### 10.2 FAST PAIRING AFTER TRANSMISSION INTERRUPTION

If no signal is received from one of your already paired transmitters for more than 15 minutes (e.g. cycling without pulse-chest belt, magnet moved unintentionally) the receive channel for this transmitter will be closed. In this case your VDO computer will show dashes for the

respective function in the display. To re-open all receive channels press the **1** and **A** buttons at the same time:



In this case your VDO computer will then receive all paired transmitters that are in range. See also chapter 15 Sleep mode.

### 10.3. GETTING STARTED - quick overview Functions/operation/reset/max values

#### 10.3.0. PERMANENT FUNCTIONS

The following functions are permanently shown in the display:

#### HEADER

- actual cadence (optional)

#### CENTER BAR

- Heart rate receive icon if the pulse transmitter belt is worn
- Beeper icon if the beeper is switched on
- Stopwatch icon if the timing function is running
- Actual heart rate
- Actual speed: Maximum value 120 km/h or mph (! not in walk mode !)
- Comparison of actual speed to average speed ▲ = above, ▼ = below (! not in walk mode !)
- Selected wheel size 1 or 2
- REC for ongoing recording

#### FOOTER

- Shows selected information and corresponding value

## BICYCLE FUNCTIONS (button 1)

With the exception of the CLOCK function NO bicycle functions are available in walk mode. The 1 button has no function in walk mode.

10.3.1. ⊗ TRIP DISTANCE = distance of the actual trip

Display 1 TRIP DISTANCE  
 Reset: 3 sec. 2 TRIP DATA ?RESET?  
 M TRIP DATA ?RESET? <<?RESET?>> flashing  
 M TRIP DATA RESET DONE

This resets all data of the functions marked by ●

Automatic return to operation mode for TRIP DIST.

Maximum value: 999.99 KM or MI. If this number is overranged then TRIP DISTANCE, RIDE TIME, and AVERAGE SPEED will be set to ZERO.

10.3.2. ⊗ RIDE TIME = ride time of the actual trip

With auto start/stop function: Starts automatically when you start off and stops automatically when you stop.

Display 1 RIDE TIME  
 Reset: 3 sec. 2 TRIP DATA ?RESET?  
 M TRIP DATA ?RESET? <<?RESET?>> flashing  
 M TRIP DATA RESET DONE ●

Automatic return to operation mode for TRIP DIST.

Maximum value 24 hours. If this number is overranged then TRIP DISTANCE, RIDE TIME, and AVERAGE SPEED will be reset to ZERO.

10.3.3. ⊗ AVG SPEED = average speed of the actual trip

Display 1 AVG SPEED  
 Reset: 3 sec. 2 TRIP DATA ?RESET?  
 M TRIP DATA ?RESET? <<?RESET?>> flashing

This resets all data of the functions marked by ●

M TRIP DATA RESET DONE ●

Automatic return to operation mode for TRIP DIST.

Accuracy: 2 decimal places. If DAILY DISTANCE or RIDE TIME are overranged this value will be reset to ZERO.

10.3.4. ⊗ MAX SPEED = maximum speed of the actual trip

Display 1 MAX SPEED  
 Reset: 3 sec. 2 TRIP DATA ?RESET?  
 M TRIP DATA ?RESET? <<?RESET?>> flashing  
 M TRIP DATA RESET DONE ●

Automatic return to operation mode for TRIP DIST.

Maximum value 120 km/h or mph. Accuracy 2 decimal places. Not suitable for motorcycles.

## OPTION ONLY WITH CADENCE EXTENSION

10.T1. ⊗ CAD AVG = average cadence of the actual trip

Display 1 CAD AVG  
 Reset: 3 sec. 2 TRIP DATA ?RESET?  
 M TRIP DATA ?RESET? <<?RESET?>> flashing  
 M TRIP DATA RESET DONE ●

Automatic return to operation mode for TRIP DIST

10.T2. ⊗ CAD MAX = maximum cadence of the actual trip

Display 1 CAD MAX  
 Reset: 3 sec. 2 TRIP DATA ?RESET?  
 M TRIP DATA ?RESET? <<?RESET?>> flashing  
 M TRIP DATA RESET DONE ●

Automatic return to operation mode for TRIP DIST

**BICYCLE FUNCTIONS** (button **2**)

IMPORTANT NOTE: NO bicycle functions except the CLOCK function are available in walk mode. The **2** button in walk mode automatically shows the actual time.

## 10.3.5. CLOCK

Setting, see chapter 4.2. (Either in 12h or 24h format; in 12h format am/pm will be shown as well)

Display **2** CLOCK

10.3.6. **2** NAVIGATOR

Setting, use, see chapter 11.1.-11.2.

Display **2** NAVIGATOR

Reset: 3 sec. **2** TRIP DATA ?RESET?

**▼** NAVIGATOR ?RESET?

**M** NAVIGATOR ?RESET? <<?RESET?>> flashes

**M** NAVIGATOR RESET DONE

10.3.7. **2** ODO BIKE 1 = total distance bike 1

Shows the sum of all distances ridden with bike 1 in km or mi (automatic conversion of all values when converting to mi)

Display **2** ODO BIKE 1

Maximum value: 99,999 km or mi

10.3.8. **2** ODO BIKE 2 = total distance bike 2

Shows the total of all distances ridden with bike 2 in km or mi (automatic conversion of all values when switching to mi)

Display **2** ODO BIKE 2

Maximum value: 99,999 km or mi

10.3.9. **2** ODOTOTAL = total distance bike 1 and bike 2

Shows the total of all distances ridden with bike 1 and bike 2 in km or mi (automatic conversion of all values when switching to mi)

Display **2** ODOTOTAL

Maximum value 199,999 km or mi

10.3.10. **2** TIME BIKE 1 = total time bike 1

Shows the total time of all day trips ridden with bike 1 in hhh:mm

Display **2** TIME BIKE 1

Maximum value 999:59 hhh:mm

10.3.11. **2** TIME BIKE 2 = total ride time bike 2

Shows the total time of all day trips ridden with Bike 2 in hhh:mm

Display **2** TIME BIKE 2

Maximum value 999:59 hhh:mm

10.3.12. **2** TOTAL TIME = total ride time bike 1 and bike 2

Shows the total time of all day trips ridden with bike 1 and bike 2 in hhh:mm

Display **2** TOTAL TIME

Maximum value: 1999:59 hhhh:mm

**HEART RATE FUNCTIONS** (button **2**)

PLEASE NOTE: All heart rate functions with the exception of „actual heart rate“ display require a running stopwatch or a running timer.

### 10.3.13. ⌚ 🕒 STOPWATCH = manual stopwatch

Prerequisite: Only after selecting stopwatch, chapter 12.1.

Display	<b>P</b>	STOPWATCH
Start measuring	<b>STW</b>	Press
Stop measuring	<b>STW</b>	Press

Display pulse data	<b>P</b>	LIMIT LO HI (values run sequentially, automatically in 2 second rhythm)
--------------------	----------	---

Reset: **STW** Press button for 4 sec.

Compare chapter 13. Training with recording of the residence times in the pulse ranges

### 10.3.14. ⌚ 🕒 TIMER = timer 1 / timer 2 / timer 1+2

Prerequisite: Only after selecting timer, chapter. 12.1.

Display	<b>P</b>	
Start measuring	<b>STW</b>	Press
End of measurement		Automatic after timer period elapses (or number of sequences for timer 1+2), beeper signal
Display pulse data	<b>P</b>	LIMIT LO HI (values run sequentially, automatically in 2 second rhythm)

Reset: **STW** Press button for 4 sec.

Compare chapter 13.2. Training with recording of the residence times in the pulse ranges

### 10.3.15. ⌚ 🕒 COUNTDOWN = countdown timer

Prerequisite: Only after selection of countdown timer, chapter 12.1.

Display	<b>P</b>	
Start measuring	<b>STW</b>	Press
End of measurement		Automatic after elapse of countdown, beeper signal

Display pulse data	<b>P</b>	LIMIT LO HI (values run sequentially, automatically in 2 second rhythm)
--------------------	----------	---

Reset: **STW** Press button for 4 sec.

Compare Chapter 13.3. Training with the countdown timer

### 10.3.16. ⌚ 🕒 LAP-TIMER = lap timer

Prerequisite: Only after selection of lap timer, Chapter 12.1.



Display	<b>P</b>	
Start measuring	<b>STW</b>	Press
Go to next lap	<b>A+P</b>	Press buttons at the same time
End/pause measurement	<b>STW</b>	Press
Display lap data	<b>P</b>	LAP REC
	<b>STW</b>	Go to the next lap data
Reset:	<b>STW</b>	Press button for 4 sec.

Compare Chapter 13.4. Training with the countdown timer.

### 10.3.17. ⌚ 🕒 AVG PULSE = average pulse of the actual timing period



Prerequisite: Only with running or stopped and not deleted stopwatch/timer/countdown/lap timer function

Displaying the information	<b>P</b>	AVG PULSE
Reset:	<b>STW</b>	Press button for 4 sec.



10.3.18.   MAX PULSE = maximum pulse of the actual timing period

Prerequisite: Capture only with running or stopped and not deleted stopwatch/timer/countdown/lap timer function

Displaying the information  MAX PULSE  
Reset:  Press button for 4 sec.

10.3.19.   PULSE MAX % = pulse as a percentage of personal maximum pulse



Prerequisite: Only with running or stopped and not deleted capture of stopwatch/timer/countdown/lap timer ()



Displaying the information  PULSE MAX %  
Reset:  Press STW button for 4 sec.

10.3.20.   LIMIT LO HI = residence times in the pulse ranges

Prerequisite: Only with running or stopped and not deleted capture of stopwatch/timer/countdown/lap timer

Only if personal data have been entered, chapter 6. Always based on selected training program (limit 1, 2, or 3), chapter 7.3.

Displaying the information  LIMIT LO HI (values run sequentially in 2 second rhythm)  
Reset:  Press button for 4 sec.

10.3.21.   RECOV TIME or RECOV PULSE = recovery time and recovery pulse measurement

Prerequisite: Only if recovery time/recovery pulse is defined, chapter 7.4.

Starting the measurement  press simultaneously  
Displaying the information  RECOV TIME or RECOV PULSE

Reset:  Press button for 4 sec.

10.3.22.   CALORIE = calorie consumption of the actual timing period

Prerequisite: Only with running or stopped and not deleted stopwatch/timer/countdown/lap timer function

Only if personal data have been entered, chapter 6.

Displaying the information  CALORIE  
Reset:  Press button for 4 sec.

## 11. RIDING WITH THE NAVIGATOR

With the VDO Navigator you can complete trips according to Roadbooks (e.g. Moser Guide). Roadbooks are offered by many publishing houses for fantastic trips (for road bikes as well as mountain bikes) by many publishing houses. Taking a specified trip is facilitated thanks to the detailed km description of certain orientation points.

Note: This function is not available in walk mode.

The VDO Navigator is an independent km or mi counter and works in the following modes:

- a. Counting down: To display the distance remaining to the next orientation point
- b. Counting up: To display the distance covered since the last orientation point

Note: The Navigator always runs automatically even if you have not set it.

The Navigator km status can be set/changed at any point desired. Thus you can start in the middle of a trip or execute a km correction if you took a wrong turn.

### 11.1. SELECTING NAVIGATOR MODE

- 3 sec. **1** Setting mode LANGUAGE SELECT
- ▼▲** NAVIGATOR SET
- M** NAVIGATOR FORWARD (**▼** to go to NAVIGATOR BACKWARD)
- M** NAVIGATOR NEXT DIGIT
- ▼▲** Set last digit (keep button depressed for fast run-

- through)
- M** „NAVIGATOR NEXT DIGIT  
... repeat for all digits from back to front
- M** NAVIGATOR ?SET OK?
- ▼▲** Set first digit (keep button depressed for fast run-through)
- M** NAVIGATOR SET DONE

Automatic return to the operation mode for NAVIGATOR

### 11.2. RESETTING THE NAVIGATOR AT THE ORIENTATION POINT

- 3 sec. **2** TRIP DATA ?RESET?
- ▼▲** NAVIGATOR ?RESET?
- M** NAVIGATOR ?RESET? <<?RESET?>> flashes
- M** NAVIGATOR RESET DONE

Automatic return to the operation mode for NAVIGATOR  
Navigator reset done

## 12. THE TIMING FUNCTIONS

The following settings are of particular importance when using the pulse functions (chapter 13).

Your VDO computer has 6 different timing functions. If one of the timing functions is running the TIMING indicator icon  will always be flashing in the left part of the display. Moreover the residence times in the training ranges are captured for each running timing function (see chapter Kap. 13). The setting range/measuring range for all timing functions is 0:00:00 h to 24:00:00 h

**TIMER 1:** You can program a time e.g. for interval training. TIMER 1 counts from zero forward. At the end of TIMER 1 there is a single beep. Timer 1 only functions if you have set a time. If you have forgotten to set a time your VDO computer displays TIMER ERROR

**TIMER 2:** You can program a time, e.g. for the rest phase in an interval training. TIMER 2 counts from zero forward. At the end of TIMER 2 there are two beeps. Timer 2 only functions if you have set a time. If you have forgotten to set a time your VDO computer displays TIMER ERROR

**TIMER 1+2** runs until you stop these functions. Timers 1 + 2 only function if you have set a time. If you have forgotten to set a time your VDO computer displays TIMER ERROR.

**COUNTDOWN:** You can program a time, the timer will count backwards from this time. At the end of the COUNTDOWN time there is a single beep. Countdown only functions if you have set a time. If you have forgotten to set a time your VDO computer will display COUNTDOWN ERROR.

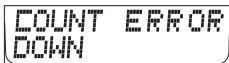

**LAP TIMER:** Start Lap Timer with **STW**. Start next Lap with **P** + **A** at the same time at any point of the training unit. The following values will be saved:

- Duration of the lap
- Average heart rate on the lap

- Average speed on the lap  
The lap values can be called at any time if time measurement is stopped.

**STOPWATCH:** With the manual stopwatch you can manually capture the plus values of training units.

### 12.1. SELECTING THE TIMING FUNCTION

- 3 sec. **1** Setting mode LANGUAGE SELECT  
**▼▲** TIMER SETTINGS  
**M** TIMER ?SELECT?  
 Select **M** TIMER 1 ?SELECT?  
 Timer **▼** TIMER 2 ?SELECT?  
**▼** TIMER 1 + 2 ?SELECT? >>> Query repeats TIMER  
 1 + 2 REPEATS ?SELECT?  
**▼** COUNTDOWN ?SELECT?  
**▼** LAP TIMER ?SELECT?  
**▼** STOP WATCH ?SELECT?  
**M** Confirm selection SET DONE

If you have not yet set any values for timer 1, timer 2, timer 1 +2, or countdown, then your VDO computer will now show ERROR in the display. In this case proceed as explained in the following chapter 12.2 Setting the timer.

### 12.2. SETTING THE TIMER (when selecting timer 1 or timer 2 or timer 1+2)

- Setting times for timer 1/timer 2  
 3 sec. **1** Setting mode LANGUAGE SELECT  
**▼▲** TIMER SETTINGS

- Select
- M** TIMER ?SELECT?
  - ▼** TIMER ?SET?
  - M** TIMER 1 ?SET?
  - ▼** TIMER 2 ?SET?
  - M** TIMER ?SET?
  - M** SET HOUR ?CONTINUE?
  - ▼ ▲** Setting hours (keep button depressed for fast run-through)
  - M** SET MINUTES ?CONTINUE?
  - ▼ ▲** Setting minutes (keep button depressed for fast run-through)
  - M** SET SECONDS ?CONTINUE?
  - ▼ ▲** Setting seconds (keep button depressed for fast run-through)
  - M** TIMER ?SET OK?
  - M** TIMER SET DONE

Automatic return to the operation mode for TIMER 1/2. If you have not yet set any values for timer 1, and/or timer 2, then your VDO computer will now show ERROR in the display.

### 12.3. SETTING TIMER 1 + 2 REPEATS (when selecting timer 1 + 2)

- 3 sec. **1** Setting mode LANGUAGE SELECT
- ▼ ▲** TIMER SETTINGS
  - M** TIMER ?SELECT?
  - ▼** TIMER 1 ?SELECT?
  - ▼ ▲** TIMER 1 + 2 ?SELECT?
  - M** TIMER 1+2 REPEATS ?SELECT?
  - ▼ ▲** Setting the number of repeats (keep button de-

pressed for fast run-through)

- M** TIMER 1+2 ?SET OK?
- M** TIMER 1+2 SET DONE

Automatic return to the operation mode for TIMER 1/2. If you have not yet set any values for timer 1, and/or timer 2, then your VDO computer will now show ERROR in the display.

### 12.4 SETTING THE COUNTDOWN (when selecting countdown timer)

- 3 sec. **1** Setting mode LANGUAGE SELECT
- ▼ ▲** TIMER SETTINGS
  - M** TIMER ?SELECT?
  - ▼** TIMER ?SET?
  - M** TIMER 1 ?SET?
  - ▼** COUNTDOWN ?SET?
  - M** SET HOUR ?CONTINUE?
  - ▼ ▲** Setting hours (keep button depressed for fast run-through)
  - M** SET MINUTES ?CONTINUE?
  - ▼ ▲** Setting minutes (keep button depressed for fast run-through)
  - M** SET SECONDS ?CONTINUE?
  - ▼ ▲** Setting seconds (keep button depressed for fast run-through)
  - M** COUNTDOWN ?SET OK?
  - M** COUNTDOWN SET DONE

Automatic return to the operation mode for COUNTDOWN

If you have not yet set any values for countdown, then your VDO computer will now show ERROR in the display.

## 12.5. LAP-TIMER

The LAP timer must first be started with the **STW** button. To save the LAP data press buttons **P** + **A** at the same time on the desired points of the training unit. In this process the following values will be saved:

- Duration of the lap
- Average heart rate on the lap
- Average speed on the lap

The lap values can be called at any time if time measurement is stopped.

## 12.6. STOPWATCH

Use of the stopwatch does not require any previous setting. After preselect (see chapter 12.1), it can be stopped or started at any time with **STW**.

## 13. TRAINING CONTROL WITH THE PULSE FUNCTIONS

See chapter 12. for information on making the settings. For focused training control it is necessary to keep the pulse in certain ranges through specific stress, see chapter 7.2. The different training programs are defined by a low limit and high limit. The pulse range between the two values is usually the target range for your training. After determining the pulse ranges (automatically or manually) your VDO computer records the residency period in the target range as well as the times above and below the target range. For real-time monitoring your VDO computer indicates when you leave the target range via an acoustic signal, if you have set this function beforehand (see chapter 13.1)

## 13.1. TRAINING WITH THE STOPWATCH

The stopwatch offers the easiest possibility for capturing pulse data. When the stopwatch is running pulse data is recorded. Interruption/continuation of the recording is possible at any time with **STW**.

step 1 Preparing the recording:

- Set the training ranges automatically chapter 7.1, or manually chapter 7.2
- Select training program limit 1, limit 2, limit 3, chapter 7.3
- In the TIMER SETTINGS setting menu select STOPWATCH, chapter 12.1.

step 2 Beginning of the recording:

- 4sec. **STW** Start the recording  
**P** Switch on/switch off the acoustic pulse signal

step 3 End/interruption of the recording:

- STW** Stop the recording

step 4 Display of the values (even during recording)

- P** Display data via the LIMIT LO HI pulse menu (display automatically shows the times for the three ranges in %)
- Time above the high limit
  - Time between the limit values
  - Time under the low limit

step 5 Deleting recorded data

- 4sec. **STW**



TIP: At the end of the training unit measure the recovery time or the recovery pulse to determine your training status. See 7.4. Recovery time and recovery pulse

Note: All bicycle altitude and pulse function can also be called up during timer operation via the **1 2 A P** buttons.

## 13.2. TRAINING WITH TIMER 1 / TIMER 2 / TIMER 1+2

Independently of each other Timer 1 or timer 2 offer the possibility of integrating intervals with manual control in the training.

Timer 1: Programmable timer with forward counting, auto-repeat function, single beep after elapse of timer 1.

Timer 2: Programmable timer with forward counting. Auto-repeat function, double beep after elapse of timer 2.

### Combination timer 1+2:

The combination of timer 1+2 can be set optimally for interval training:

Timer 1 = active phase, timer 2 = rest phase. When timer 1 elapses a single beep sounds, when timer 2 elapses a double beep sounds. For timer 1+2 you can set the number of repeats. In this case time 1+2 runs until all repeats have elapsed or the measurement is interrupted by **STW**.

**IMPORTANT:** During timer operation the residence periods of the pulse frequency in the selected training ranges is recorded (compare 12.1)

### step 1 Preparing the recording

- Set the training ranges automatically chapter 7.1, or manually chapter 7.2

- Select training program limit 1, limit 2, limit 3, chapter 7.3  
- In the **TIMER SETTINGS** setting menu select the desired timer

### step 2 Beginning of the recording:

**STW** Start the recording

4sec. **P** Switch on/switch off the acoustic pulse signal

### step 3 End/interruption of the recording:

**AUTOMATIC** depending on timer selection at the end of the respective timer or at the end of all selected repeats with the combination function timer 1+2

**STW** Manual interruption = stop recording

### step 4 Display of the values (even during recording):

**P** Display data via the **LIMIT LO HI** pulse menu (display automatically shows the times for the three ranges in %)

- Time above the high limit  
- Time between the limit values  
- Time under the low limit

### step 5 Deleting recorded data

4sec. **STW**

Note: All bicycle altitude and pulse function can also be called up during timer operation via the **1 2 A P** buttons.

TIP: At the end of the training unit measure the recovery time or the recovery pulse to determine your training status, see chapter 7.4. Recovery time and recovery pulse.

### 13.3. TRAINING WITH THE COUNTDOWN TIMER:

The countdown timer is a programmable timer with reverse counting. This is particularly well-suited for use in time trials. At the end of the COUNTDOWN time there is a single beep.

**IMPORTANT:** During countdown operation the residence periods of the pulse frequency in the selected training ranges are recorded (compare 12.1)

#### step 1 Preparing the recording:

- Set the training ranges automatically chapter 7.1, or manually chapter 7.2
- Select training program limit 1, limit 2, limit 3, chapter 7.3
- In the setting menu TIMER SETTINGS select AND set the countdown timer, chapter 12.1 and following.

#### step 2 Beginning of the recording:

- 4sec.  Start the recording
- 4sec.  Switch on/switch off the acoustic pulse signal

#### step 3 End/interruption of the recording:

AUTOMATIC after the countdown time elapses

-  Manual interruption = stop recording

#### step 4 Display of the values (even during recording)

-  Display data via the LIMIT LO HI pulse menu  
(Display automatically shows the times for the three ranges in %)
- Time above the high limit
  - Time between the limit values

- Time under the low limit

#### step 5 Deleting recorded data

4sec. 

**TIP:** At the end of the training unit measure the recovery time or the recovery pulse to determine your training status, see chapter 7.4.

Recovery time and recovery pulse.

**Note:** All bicycle altitude and pulse function can also be called up during timer operation via the **1 2 A P** buttons.

**TIP:** At the end of your countdown timer measure the recovery time or the recovery pulse to determine your training status. See 7.4. Recovery time and recovery pulse.

### 13.4. TRAINING WITH THE LAP TIMER

The lap timer of your VDO computer is designed for lap training. You can record up to 50 laps manually. In this case your computer saves the following values for each lap:

- Lap time
  - Average pulse during the lap
  - Average speed during the lap (**IMPORTANT:** no display in walk mode)
- With these values you have an outstanding method of analyzing the development of your performance if you always do the same laps. This could be certain mountain values or flat stretches on your training lap. The lap timer function can be set in bicycle mode and in walk mode.

**Important:**

1. The values saved for the individual laps can only be shown in the

display in recall mode after concluding the measurement.

2. If the lap timer is running the residence period of the pulse frequency in the selected training ranges is recorded (compare 12.1)

step 1 Preparing the recording:

- Set the training ranges automatically chapter 7.1, or manually chapter 7.2
- Select training program limit 1, limit 2, limit 3, chapter 7.3
- In the TIMER SETTINGS setting menu select the lap timer chapter 12.1

step 2 Starting/changing/interrupting laps:

- P** Switch on/switch off the acoustic pulse signal
- STW** Start lap 1

Press concurrently:

- A+P** End lap 1 and start lap 2 concurrently

Start next lap:

- A+P** End lap 2 and start lap 3 concurrently...

Interrupt: **STW** Interrupt lap measuring (e.g. for recovery lap or break)

You can interrupt each lap as often as desired, or end the lap and record up to 50 individual laps.

step 3 Display the values (during a break or after ending the lap training).

- Prerequisite: The lap timer must be stopped (**STW**)
- P** Display data via the pulse menu LAP REC
- Display of values for LAP 1 (Fig. display)

Center bar left: Average pulse on the lap

Center bar right: Average speed on the lap (IMPORTANT: no display in walk mode)

Footer: Lap number and time of the lap

**STW** Changing the display of values for lap 2

**STW** Changing the display of values for lap 3

...

During or after lap training the pulse data can be displayed at any time: Display data via the LIMIT LO HI pulse menu (display automatically shows the times for the three ranges in %)

- Time above the high limit
- Time between the limit values
- Time under the low limit

step 5 Deleting all recorded lap data

4sec. **STW**

TIP: At the end of the training unit measure the recovery time or the recovery pulse to determine your training status. See 7.4. Recovery time and recovery pulse

NOTE for DATA RECORDING:

All lap data is also recorded when using DATA RECORDING (chapter 14) and is also transferred to the PC in the data transfer. With the aid of the „PC-Sport“ training software the lap data can then be displayed on the PC.

#### 14. THE DATA RECORDING FUNCTION & TRANSFER OF DATA TO THE PC

Your VDO computer is designed for recording data and transferring data to your PC. The recorded and transferred data can be analyzed on the PC. With the „PC-Sport“ software you can keep a training journal, track developments over certain periods, and specifically plan a program for getting in shape. All necessary elements for this application are included in the scope of delivery of your computer:

1. Docking station with USB cable for transferring data to the PC
2. CD-ROM with the PC-Sport training and analysis software

What happens when I record training units?

Your VDO computer generates a file/data record in its memory per training unit (start/stop see below). The following data is captured in this data record (after starting data recording) in a interval (10 / 20 sec.):

- All bike data (only under certain conditions in walk mode)
- All altitude data (only under certain conditions in walk mode)
- All pulse data (only under certain conditions in walk mode)
- Lap data if lap timer is used
- All cadence data (if the cadence kit is installed)

Note:

If you are using the lap timers the lap data will have a flag. When transferring data from the computer to the PC the lap data are identified via this flag and are displayed and analyzed separately in the PC-Sport program.

**IMPORTANT INFORMATION PLEASE NOTE THE FOLLOWING:**

- a. The storage capacity of the device is configured for a total of 100 training hours.
- b. After this total time is exceeded the new data automatically over-

writes the oldest data in the memory.

- c. A manual delete of training data is not possible.
- d. Due to the recording interval of 10 or 20 sec. there may be slight deviation between the data in your VDO computer and the data in the PC-Sport program (e.g. average pulse)

TIPP: Connect your VDO computer to your PC at regular intervals so that important data is not overwritten. Manual control/read out of the data records of the DATA RECORDING and a data delete is not possible on your VDO computer itself.

#### 14.1. STARTING/STOPPING DATA RECORDING

You must start data recording manually:

Start data recording:

Press **P** + **1** concurrently

Start of data recording  
REC is displayed in the center bar

End data recording:

Press **P** + **1** concurrently

Stop data recording  
REC is not illuminated



What happens when I take a break?

If you take a break during DATA RECORDING, and the computer goes into SLEEP MODE after 5 minutes (chapter 15) then DATA RECORDING will be interrupted automatically. If SLEEP MODE is ended by pressing a button then DATA RECORDING will be automatically continued.

TIP: Leave your VDO computer on the handlebar holder so that sleep mode is activated and recording is interrupted automatically after 5 minutes (see chapter 15 Sleep mode).

ATTENTION: If you manually interrupt data recording, for a break for example by pressing **P** + **1**, then a new data record will be generated at restart. Even if you do a trip data reset during „DATA RECORDING“ your VDO computer will generate a new data record.

## 14.2. TRANSFERRING DATA TO YOUR PC >>> P11

Install the PC-Sport software on your PC. Insert your VDO computer into the docking station as shown and connect the USB cable to one of your computer's USB ports. Now start PC Sport

- Under „FILE“ select Import
- In Import select VDO series Z

Click on the Start button in the PC Sport program, then on the Z3 go to setting mode

- 3 sec. **1** Setting mode LANGUAGE SELECT  
**▼▲** PC LINK SELECT  
**M** PC LINK SENDING (the data transfer is indicated in the display by changing numbers)

Now the PC receives the data of your VDO computer. Data transfer is indicated by the changing numbers in the computer's display.

NOTE: When importing the files the PC-Sport program detects which files have already been imported. If you want to import this again you must select it manually and confirm a warning query.  
Now follow the instructions on saving files in the PC-Sport program.

Please see the PC Sport electronic user manual on the CD-ROM for all additional information relative to planning and analysis of training units

## 14.3. SELECTION OF THE RECORDING INTERVAL

Your VDO computer offers two recording intervals (10 seconds or 20 seconds) for data recording.

Interval 1:	20 seconds
Maximum recording period:	100 hours
Selection of the recording interval:	Press <b>A+2</b>
Interval 2:	10 seconds
Maximum recording period:	50 hours
Selection of the recording interval:	Press <b>A+2</b>

Now the recording interval that has been set is shown in the display:

DATA RECORD  
INTERVAL  
10 SEC  
20 SEC

- ▼▲** UP/Down - changes to the other interval.  
**M** Press M to confirm your selection.

ATTENTION: It is not possible to switch the recording interval during a recording.

**15. SLEEP MODE**

Your VDO computer has a two-stage sleep mode. Sleep mode is activated automatically if the computer no longer receives data.

Phase 1 after 5 minutes: - The display goes into sleep mode  
- DATA RECORDING is interrupted

Now the display shows time, date, and day of the week.

FOR WAKE UP                      press any button.

Description special case 1.

No speed signals (e.g. when taking a break)

No cadence signals (e.g. when taking a break)

Pulse signals will continue to be received (e.g. computer on wrist)

In this case the receive channels for speed and cadence are opened for a total of 3 hours. Energy is consumed in this process.

To extend the service life of the batteries, leave your VDO computer in the handlebar holder and move out of the receive range, or take off the pulse transmitter belt.







**16. TROUBLESHOOTING**



Here is a list of possible errors, their causes, and what you can do to correct the error:

Problem when pairing the speed transmitter/cadence transmitter	<ul style="list-style-type: none"> <li>- Check the magnet position (distance between magnet and transmitter, position of the magnet to the transmitter point on the transmitter)</li> <li>- Check the battery in the transmitter</li> <li>- Check the battery in the computer (if battery voltage is insufficient then the receiver cannot receive the signals)</li> </ul>
Problem when pairing the pulse-chest belt	<ul style="list-style-type: none"> <li>- Check the battery in the chest belt</li> <li>- Check the battery in the computer (if battery voltage is insufficient then the receiver cannot receive the signals)</li> </ul>

No speed display	<ul style="list-style-type: none"> <li>- Check the magnet position (distance between magnet and transmitter, position of the magnet to the transmitter point on the transmitter)</li> <li>- Check the battery in the transmitter</li> <li>- Check the battery in the computer (if battery voltage is insufficient then the receiver cannot receive the signals)</li> </ul>
No cadence display	<ul style="list-style-type: none"> <li>- Check the magnet position (distance between magnet and transmitter, position of the magnet to the transmitter point on the transmitter)</li> <li>- Check the battery in the transmitter</li> <li>- Check the battery in the computer (if battery voltage is insufficient then the receiver cannot receive the signals)</li> </ul>

No speed display (dash in the display)	<p>The receive channel for speed is switched off (a 15-minute period has elapsed without receiving a speed signal)</p> <p>Press buttons <b>A</b> + <b>1</b> at the same time</p>
No cadence data (dash in the display)	<p>The receive channel for cadence is switched off (a 15-minute period has elapsed without receiving cadence signals)</p> <p>Press buttons <b>A</b> + <b>1</b> at the same time</p>
No pulse display (dash in the display)	<p>The receive channel for pulse is switched off (a 15-minute period has elapsed without receiving pulse data)</p> <p>Press buttons <b>A</b> + <b>1</b> at the same time</p>
No average pulse	<p>Timer has not been started</p> <p>Start timer</p>
No maximum pulse	<p>Timer has not been started</p> <p>Start timer</p>

No pulse percentage of the personal maximum pulse	Personal data has not been set, timer has not been started
No data relative to training times is in the set training ranges	Timer has not been started. Start timer
Calorie display does not function	Personal data has not been set, timer has not been started
LAP data cannot be displayed/ are no longer present	The LAP data have been deleted prior to LAP RECALL
Tool-Icon is flashing on the display 	Service interval for your bicycle is displayed. Take your bicycle in for service or perform the service yourself
Walking shoe is shown in the display (bicycle distance data is no longer displayed) 	Walk mode is switched on. In walk mode certain bike functions are not available
The timer indicator is flashing 	A timer is still running.
Bell icon is displayed 	An alarm is set (alarm time)
The LAP icon is flashing 	A LAP recording is still running. End recording with the  button

The REC icon is flashing 	Data recording is running. All data is recorded in the computer and can be transferred later to the PC. End data recording with button  + 
Data download from Z3 PC-Link/ Z2 PC-Link to the PC does not function	<ul style="list-style-type: none"> <li>- Ensure that the computer is correctly mounted on the docking station</li> <li>- Ensure that the docking station is correctly connected to the PC via USB connector</li> <li>- Ensure that the PC Sport software is open</li> <li>- Ensure that PC-LINK has been called and started in the computer</li> <li>- Ensure that the file Import VDO series Z has been opened and started in the PC Sport program.</li> </ul>

## 17. GUARANTEE CONDITIONS

VDO Cycle Parts offers a 5-year guarantee on your VDO computer, starting from date of purchase. The guarantee extends to material and manufacturing defects on the computer itself, on the docking station, on the transmitters and on the handlebar and wrist band holder. Cable and batteries, as well as other mounting materials are excluded from the guarantee.

The guarantee is only valid if the components in questions have not been opened (exception: battery compartment of the computer), if force has not been applied, and if willful damage is not present. Please keep the purchase receipt in a safe place because it must be submitted if there is a complaint. You will receive a comparable replacement device if there is a legitimate complaint.

A claim for replacement of the identical model does not exist if the model in question is no longer in production due to a model change. Please contact the dealer from whom you purchased the device for all complaints and guarantee claims. Or send your complaint directly to

Cycle Parts GmbH, Große Ahlmühle 33, D-76865 Rohrbach.

We would be pleased to answer any technical questions you might have at the following hotline number:  
+49-6349-9635-10.

Additional technical information is available at:  
<http://www.vdocyclecomputing.com>

In the course of further development we reserve the right to make technical changes without prior notice.

## 18. TECHNICAL SPECIFICATIONS

Computer: Approximately 49.6 x 46.6 x 16.5 mm, weight:

Approximately 45 g

Handlebar holder: Weight approximately 15 g

Speed transmitter: Weight approximately 20 g

Pulse transmitter: Weight approximately 80 g

Battery: 3V, type 2032 (computer); type 2032 (speed transmitter); type 2032 (pulse transmitter)

Battery service life:

Computer: Approximately 300 hours, approximately 8000 KM (5000 M) (speed only)

Pulse transmitter: Approximately 800 hours

Working temperature of the display: -15 °C to +60 °C

Speed range: for wheel size 2155 mm, min 3 km/h, max 120 km/h

Ride time measurement range: Up to 24:00:00 HH:MM:SS

Stopwatch measurement range: Up to 24:00:00 HH:MM:SS

Day trip measurement range: Up to 999.99 km or mi.

NAVIGATOR measurement range: Up to 999.99 km or mi.

Total KM 1 and 2 measurement range: Up to 99,999 km or mi.

Total kilometers measuring range: Up to 199,999 km or mi.

Wheel size: 100 mm minimum, 3999 mm maximum

Memory versions:

Recording capacity: 100 hours, a maximum of 100 trips at 1 hour each

## 18. ESPECIFICACIONES TECNICAS

Ciclocomputador: Aproximadamente 49,6 x 46,6 x 16,5mm, peso:

Aproximadamente 45g

Soporte manillar: Peso aproximado 15g

Transmisor de velocidad: Peso aproximado 20g

Transmisor de pulso: Peso aproximado 80 g

Baterías: 3V, tipo 2032 (ciclocomputador); tipo 2032 (transmisor de velocidad); tipo 3032 (transmisor de pulso)

Duración de la batería:

Ciclocomputador: Aproximadamente 300 horas, aproximadamente 8.000 km(5.000 millas) ( sólo velocidad)

Transmisor de pulso: Aproximadamente 800 horas

Temperatura de la pantalla para funcionamiento: -15°C a +60°C

Alcance de la velocidad: para rueda de 2.155mm, míni 3km/h, máx. 120km/h

Alcance del cálculo de tiempo: Hasta 24:00:00 HH:MM:SS

Alcance del cálculo del cronómetro: Hasta 24:00:00 HH:MM:SS

Alcance del cálculo de un día de ruta: hasta 999,99 km o mi.

Alcance del cálculo del NAVIGATOR: hasta 999,99 km o mi.

Alcance del cálculo de KM totales 1 y 2: hasta 99,999 km o mi.

Alcance del cálculo de kilómetros totales: hasta 199,999 km o mi.

Tamaño de rueda: mínimo 100mm, máximo 3.999mm

Versiones de memoria:

Capacidad de grabación: 100 horas, un máximo de 100 rutas de una hora cada una.

GB

#### Correct Disposal of This Product (Waste Electrical & Electronic Equipment)



(Applicable in the European Union and other European countries with separate collection systems) This marking shown on the product or its literature, indicates that it should not be disposed with other household wastes at the end of its working life.

■ To prevent possible harm to the environment or human health from uncontrolled waste disposal, please separate this from other types of wastes and recycle it responsibly to promote the sustainable reuse of material resources. Household users should contact either the retailer where they purchased this product, or their local government office, for details of where and how they can take this item for environmentally safe recycling. Business users should contact their supplier and check the terms and conditions of the purchase contract. This product should not be mixed with other commercial wastes for disposal.

D

#### Korrekte Entsorgung dieses Produkts (Elektromüll)



(Anzuwenden in den Ländern der Europäischen Union und anderen europäischen Ländern mit einem separaten Sammelsystem)

Die Kennzeichnung auf dem Produkt bzw. auf der dazugehörigen Literatur gibt an, dass es nach seiner Lebensdauer nicht zusammen mit dem normalen Haushaltsmüll entsorgt werden darf. Entsorgen Sie dieses Gerät bitte getrennt von anderen Abfällen, um der Umwelt bzw. der menschlichen Gesundheit nicht durch unkontrollierte Müllbeseitigung zu schaden. Recyceln Sie das Gerät, um die nachhaltige Wiederverwertung von stofflichen Ressourcen zu fördern. Private Nutzer sollten den Händler, bei dem das Produkt gekauft wurde, oder die zuständigen Behörden kontaktieren, um in Erfahrung zu bringen, wie sie das Gerät auf umweltfreundliche Weise recyceln können. Gewerbliche Nutzer sollten sich an Ihren Lieferanten wenden und die Bedingungen des Verkaufsvertrags konsultieren. Dieses Produkt darf nicht zusammen mit anderem Gewerbemüll entsorgt werden.

DK

#### Korrekt affaldsbortskaffelse af dette produkt (elektrisk & elektronisk udstyr)



Mærket på dette produkt eller i den medfølgende dokumentation betyder, at produktet ikke må bortskaffes sammen med almindeligt husholdningsaffald efter endt levetid. For at undgå skadelige miljø- eller sundhedspåvirkninger på grund af

■ ukontrolleret affaldsbortskaffelse skal dette produkt bortskaffes særskilt fra andet affald og indleveres berøigt til fremme for bæredygtig materiale genvinning. Hjemmebrugere bedes kontakte forhandleren, hvor de har købt produktet, eller den lokale myndighed for oplysning om, hvor og hvordan de kan indlevere produktet med henblik på miljøforvarlig genvinning. Erhvervsbrugere bedes kontakte leverandøren og læse betingelserne og vilkårene i købekontrakten. Dette produkt bør ikke bortskaffes sammen med andet erhvervsaffald.

SK

#### Správna likvidácia tohoto výrobku (Elektrotechnický a elektronický odpad)



Toto označenie na výrobku alebo v sprievodnej brožúre hovorí, že po skončení jeho životnosti by nemal byť likvidovaný s ostatným odpadom. Prípadnému poškodeniu životného prostredia alebo, uškého zdravia môžete predísť tým, že budete

■ takéto typy výrobkov oddeľovať od ostatného odpadu a vrátiť ich na recykláciu. Používatelia v domácnostiach by pre podrobné informácie, ako ekologicky bezpečne naložiť s týmito výrobkami, mali kontaktovať buď predajcu, ktorý im výrobok predal, alebo príslušný úrad v okolí ich bydliska. Priemyselní používatelia by mali kontaktovať svojho dodávateľa a overiť si podmienky kúpnej zmluvy. Tento výrobok by nemal byť likvidovaný spolu s ostatným priemyselným odpadom.

RO

#### Evacuarea corectă a acestui produs (reziduuri provenind din aparatură electrică și electronică)



Marcajele de pe acest produs sau menționate în instrucțiunile sale de folosire indică faptul că produsul nu trebuie aruncat împreună cu alte reziduuri din gospodărie atunci când nu mai este în stare de funcționare. Pentru a preveni posibile efecte dăunătoare asupra mediului înconjurător sau a sănătății oamenilor datorate evacuării necontrolate a reziduurilor, vă rugăm să separați acest produs de alte tipuri de reziduuri și să-l reciclați în mod responsabil pentru a promova re folosirea resurselor materiale. Utilizatorii casnici sunt rugați să ia legătura fie cu distribuitorul de la care au achiziționat acest produs, fie cu autoritățile locale, pentru a primi informații cu privire la locul și modul în care pot depozita acest produs în vederea reciclării sale ecologice. Companiile sunt rugate să ia legătura cu furnizorul și să verifice condițiile stipulate în contractul de vânzare. Acest produs nu trebuie amestecat cu alte reziduuri de natură comercială.

MK

#### Правило отстранување на овој производ (Истрошена електрична и електронска опрема)



Oваа ознака прикажана на производот или во неговата документација покажува дека тој не треба да се фрла со преостанатиот отпад од домаќинствата, кога веќе нема да биде употреблив. За да се избегне можното нарушување на животната средина или на човеково здравје, како резултат на неконтролираното отстранување на отпадот, ве молиме да го одделите од другите видови отпад и совесно да го рециклирате, за да промовирате одржлива повторna употреба на материјалните ресурси. Корисниците во домаќинствата треба да се обратат до дистрибутерите кај кои го купиле производот или до локалните власти, за да ги дознаат деталите за тоа каде и како можат да го однесат производот заради рециклирање коешто е безбедно за животната средина. Деловните корисници треба да се обратат до нивните набавувачи и да ги проверат условите од договорот за купопродажба. При отстранувањето, овој производ не треба да се меша со другот комерцијален отпад.

F

#### Comment éliminer ce produit (déchets d'équipements électriques et électroniques)



(Applicable dans les pays de l'Union Européen et aux autres pays européens disposant de systèmes de collecte sélective)  
Ce symbole sur le produit ou sa documentation indique qu'il ne doit pas être éliminé en fin de vie avec les autres déchets ménagers. L'élimination incontrôlée des déchets pouvant porter préjudice à l'environnement ou à la santé humaine, veuillez le séparer des autres types de déchets et le recycler de façon responsable. Vous favoriserez ainsi la réutilisation durable des ressources matérielles. Les particuliers sont invités à contacter le distributeur leur ayant vendu le produit ou à se renseigner auprès de leur mairie pour savoir où et comment ils peuvent se débarrasser de ce produit afin qu'il soit recyclé en respectant l'environnement. Les entreprises sont invitées à contacter leurs fournisseurs et à consulter les conditions de leur contrat de vente. Ce produit ne doit pas être éliminé avec les autres déchets commerciaux.

**Corretto smaltimento del prodotto** (rifiuti elettrici ed elettronici)

(Applicabile in i paesi dell'Unione Europea e in quelli con sistema di raccolta differenziata) marchio riportato sul prodotto o sulla sua documentazione indica che il prodotto non deve essere smaltito con altri rifiuti domestici al termine del ciclo di vita. Per

evitare eventuali danni all'ambiente o alla salute causati dall'inopportuno smaltimento dei rifiuti, si invita l'utente a separare questo prodotto da altri tipi di rifiuti e di riciclarlo in maniera responsabile per favorire il riutilizzo sostenibile delle risorse materiali. Gli utenti domestici sono invitati a contattare il rivenditore presso il quale è stato acquistato il prodotto o l'ufficio locale preposto per tutte le informazioni relative alla raccolta differenziata e al riciclaggio per questo tipo di prodotto. Gli utenti aziendali sono invitati a contattare il proprio fornitore e verificare i termini e le condizioni del contratto di acquisto. Questo prodotto non deve essere smaltito unitamente ad altri rifiuti commerciali.

**A termék megfelelő leadása** (Elektromos és elektronikus készülékek hulladékkezelése)

A termékén vagy a hozzá tartozó dokumentáción szereplő jelzés arra utal, hogy hasznos élettartama végén a terméket nem szabad háztartási hulladékkal együtt kidobni. Annak érdekében, hogy megelőzhető legyen a szabálytalan hulladékleadás által okozott környezet- és egészségkárosodás, különítse ezt el a többi hulladéktól, és felelősségteljesen gondoskodjon a hulladék leadásáról, a hulladékaanyagok fenntartható szintű újrafelhasználása céljából. A háztartási felhasználók a termék forgalmazójától vagy a helyi önkormányzati szervektől kérjenek tanácsot arra vonatkozóan, hová és hogyan vihetik el az elhasznált terméket a környezetvédelmi szempontból biztonságos hulladékleadás céljából. Az üzleti felhasználók lépjenek kapcsolatba a forgalmazóval, és vizsgálják meg az adásvételi szerződés feltételeit. A terméket nem szabad leadni kereskedelmi forgalomból származó egyéb hulladékkal együtt.

**Tinkamas produkto atliekų tvarkymas** (atitarnavusi elektros ir elektronikos įranga)

Šis ženklas, pateikiamas ant produkto ar jo dokumentacijoje, nurodo, kad pasibaigus produkto tarnavimo laikui, jo negalima išmesti kartu su kitomis buitinėmis atliekomis. Kad būtų išvengta galimos nekontroliuojamo atliekų išmetimo žalos aplinkai arba žmonių sveikatai, ir siekiant skatinti aplinką tausojantį antrinių žaliavų panaudojimą, pašom atskirti jį nuo kitų rūšių atliekų ir atiduoti perdirbti. Informacijos, kur ir kaip pristatyti šį produktą saugiai perdirbti, privatūs vartotojai turėtų kreiptis arba į parduotuvę, kurioje šį produktą pirkto, arba į vietines valdžios institucijas. Verslo vartotojai turėtų kreiptis į savo tiekėją ir peržiūrėti pirkimo sutarties sąlygas. Šis produktas tvarkant atliekas negali būti sumaišytas su kitomis atliekomis.

**Изхвърляйте правилно този продукт** (отпаднако електрическо и електронно оборудване)

Това обозначение на продукта или съпътстващите го материали означава, че той не бива да бъде изхвърлян заедно с другите битови отпадъци след края на ползвания му живот. За да се предотврати възможно увреждане на околната среда или човешки живот от неконтролираното изхвърляне на отпадъци, моля, отделяйте такива продукти от другите видове отпадъци и го рециклирайте, демонстрирайки отговорно отношение към насърчането на устойчива многократна употреба на материални ресурси. При употреба за битови нужди трябва да се свържете с продавача на дребно, от когото сте закупили продукта или с местните власти за подробности относно това къде и как можете да предадете продукта за безопасно рециклиране. При употреба за стопански нужди трябва да се свържете с доставчика си и да проверите реда и условията в договора за закупуване. Този продукт не трябва да се смесва с други отпадъци на работното място.

EE

**Üige viis toote käsutusest kõrvaldamiseks** (elektriliste ja elektrooniliste seadmete jäätmed)



Selline tähistus tootel või selle dokumentidel näitab, et toodet ei tohi kasutusaja lõppemisel kõrvaldada koos muude olmejäätmetega. Selleks, et vältida jäätmete kontrollimatu kõrvaldamisega seotud võimaliku kahju tekitamist keskkonnale või inimeste tervisele ning endadega materiaalsete vahendite säästvat taaskasutust, eraldage toode muudest jäätmetest ja suunake taasringluse. Kodukasutajad saavad teavet keskkonnohutu ringlussevõtu kohta kas toote müüjal või keskkonnaametist. Firmad peaksid võtma ühendust tarnijaga ning kontrollima ostulepingu tingimusi ja sätteid. Toodet ei tohi panna muude hävitamiseks mõeldud kaubandusjäätmete hulka.

E

**Eliminación correcta de este producto** (material eléctrico y electrónico de descarte)



(Aplicable en la Unión Europea y en países europeos con sistemas de recogida selectiva de residuos) La presencia de esta marca en el producto o en el material informativo que lo acompaña, indica que al finalizar su vida útil no deberá eliminarse junto con otros residuos domésticos. Para evitar los posibles daños al medio ambiente o a la salud humana que representa la eliminación incontrolada de residuos, separe este producto de otros tipos de residuos y reciclelo correctamente para promover la reutilización sostenible de recursos materiales. Los usuarios particulares pueden contactar con el establecimiento donde adquirieron el producto, o con las autoridades locales pertinentes, para informarse sobre cómo y dónde pueden llevarlo para que sea sometido a un reciclaje ecológico y seguro. Los usuarios comerciales pueden contactar con su proveedor y consultar las condiciones del contrato de compra. Este producto no debe eliminarse mezclado con otros residuos comerciales.

NL

**Correcte verwijdering van dit product** (elektrische & elektronische afvalapparatuur)



Dit merkteken op het product of het bijbehorende informatiemateriaal duidt erop dat het niet met ander huishoudelijk afval verwijderd moet worden aan het einde van zijn gebruiksduur. Om mogelijke schade aan het milieu of de menselijke gezondheid door ongecontroleerde afvalverwijdering te voorkomen, moet u dit product van andere soorten afval scheiden en op een verantwoorde manier recyclen, zodat het duurzame hergebruik van materiaalbronnen wordt bevorderd. Huishoudelijke gebruikers moeten contact opnemen met de winkel waar ze dit product hebben gekocht of met de gemeente waar ze wonen om te vernemen waar en hoe ze dit product milieuvriendelijk kunnen laten recyclen. Zakelijke gebruikers moeten contact opnemen met hun leverancier en de algemene voorwaarden van de koopovereenkomsten nalezen. Dit product moet niet worden gemengd met ander bedrijfsafval voor verwijdering.

FIN

**Tämän tuotteen turvallinen hävittäminen** (elektroniikka ja sähkölaitteet)



Oheinen merkintä tuotteesta tai tuotteen oheismateriaalissa merkitsee, että tätä tuotetta ei tule hävittää kotitalousjätteen mukana sen elinkaaren päätyttyä. Hallitsemattomasta jätteenkäsittelystä ympäristölle ja kanssaihminen terveydelle aiheutuvien vahinkojen välttämiseksi tuote tulee käsitellä muista jätteistä erillään. Jäte on hyvä kierrättää raaka-aineiksi kestävästi ympäristökehityksen takia. Kotitalouskäyttäjien tulisi ottaa yhteyttä tuotteen myyneeseen jälleenmyyjään tai paikalliseen ympäristöviranomaiseen, jotka antavat lisätietoja tuotteen turvalisista kierrätysmahdollisuuksista. Yrityskäyttäjien tulisi ottaa yhteyttä tavarantoimittajaan ja selvittää hankintasopimuksen ehdot. Tätä tuotetta ei tule hävittää muun kaupallisen jätteen seassa.

LV

#### Izstrādājuma pareiza likvidēšana (nolietotas elektriskās un elektroniskās ierīces)



Uz izstrādājuma vai tam pievienotajās instrukcijās dotais marķējums norāda, kā to nedrīkst likvidēt kopā ar citiem sadzīves atkritumiem pēc tā ekspluatācijas laika. Lai nevērstu viedei un cilvēku veselībai iespējamo kaitējumu, kas ir saistīts ar nekontrolējamu atkritumu likvidēšanu, tas jānosūta citiem atkritumiem un jāpārstrādā, lai sekmētu materiālo resursu atbildīgu atkārtotu lietošanu. Mājsaimniecības lietotājiem jāsaņemas vai nu ar veikalā, kurā šis izstrādājums ir pirktas, vai ar pašvaldību, lai iegūtu informāciju par to, kā un kur var nodot šo izstrādājumu, lai garantētu ekoloģiski drošu reciklējumu. Rūpnieciskajiem lietotājiem jāsaņemas ar piegādātāju un jāpārbauda pirkuma līguma nosacījumi. Šo izstrādājumu nedrīkst sajaukt ar citiem likvidējamiem rūpnieciskajiem atkritumiem.

S

#### Korrekt avfallshantering av produkten (elektriska och elektroniska produkter)



Denna markering på produkten och i manualen anger att den inte bör sorteras tillsammans med annat hushållsavfall när dess livstid är över. Tilli förebyggande av skada på miljöö och hälsa bör produkten hanteras separat för ändamålsenlig återvinning av dess beståndsdelar. Hushållsanvändare bör kontakta den återförsäljare som sålt produkten eller sin kommun för vidare information om var och hur produkten kan återvinnas på ett miljösäkert sätt. Företagsanvändare bör kontakta leverantören samt verifiera angivna villkor i köpekontraktet. Produkten bör inte hanteras tillsammans med annat kommersiellt avfall.

CZ

#### Správná likvidace tohoto produktu (Zničení elektrického a elektronického zařízení)



Tato značka zobrazená na produktu nebo v dokumentaci znamená, že by neměl být používán s jinými domácími zařízeními po skončení svého funkčního období. Aby se zabránilo možnému znečištění životního prostředí nebo zranění člověka díky nekontrolovanému zničení, oddělte je prosíme od dalších typů odpadů a recyklujte je zodpovědně k podpoře opětovného využití hmotných zdrojů. Členové domácnosti by měli kontaktovat jak prodejce, u něhož produkt zakoupili, tak místní vládní kancelář, ohledně podrobností, kde a jak můžete tento výrobek bezpečně vzhledem k životnímu prostředí recyklovat. Obchodníci by měli kontaktovat své dodavatele a zkontrolovat všechny podmínky koupě. Tento výrobek by se neměl míchat s jinými komerčními produkty, určenými k likvidaci.

PL

#### Prawidłowe usuwanie produktu (zużyty sprzęt elektryczny i elektroniczny)



Oznaczenie umieszczone na produkcie lub w odnoszących się do niego tekstach wskazuje, że produktu po upływie okresu użytkowania nie należy usuwać z innymi odpadami pochodzącymi z gospodarstw domowych. Aby uniknąć szkodliwego wpływu na środowisko naturalne i zdrowie ludzi wskutek niekontrolowanego usuwania odpadów, prosimy o oddzielenie produktu od innego typu odpadów oraz odpowiedzialny recykling w celu promowania ponownego użycia zasobów materialnych jako stałej praktyki. W celu uzyskania informacji na temat miejsca i sposobu bezpiecznego dla środowiska recyklingu tego produktu użytkownicy w gospodarstwach domowych powinni skontaktować się z punktem sprzedaży detalicznej, w którym dokonali zakupu produktu, lub z organem władz lokalnych. Użytkownicy w firmach powinni skontaktować się ze swoim dostawcą! sprawdź warunki umowy zakupu. Produktu nie należy usuwać razem z innymi odpadami komercyjnymi.

P

#### Eliminação Correcta Deste Produto (Resíduo de Equipamentos Eléctricos e Electrónicos)



Esta marca, apresentada no produto ou na sua literatura indica que ele não deverá ser eliminado juntamente com os resíduos domésticos indiferenciados no final do seu período de vida útil. Para impedir danos ao ambiente e à saúde humana causados pela eliminação incontrolada de resíduos deverá separar este equipamento de outros tipos de resíduos e reciclá-lo de forma responsável, para promover uma reutilização sustentável dos recursos materiais. Os utilizadores domésticos deverão contactar ou o estabelecimento onde adquiriram este produto ou as entidades oficiais locais para obterem informações sobre onde e de que forma podem levar este produto para permitir efectuar uma reciclagem segura em termos ambientais. Os utilizadores profissionais deverão contactar o seu fornecedor e consultar os termos e condições do contrato de compra. Este produto não deverá ser misturado com outros resíduos comerciais para eliminação.

GR

#### Ισστή Διάθεση αυτού του Προϊόντος (Απορρίμματα Ηλεκτρικού & Ηλεκτρονικού Εξοπλισμού)



Τα σύμβολα που εμφανίζονται επάνω στο προϊόν ή στα εγχειρίδια που το συνοδεύουν, υποδεικνύουν ότι δεν θα πρέπει να ρίπεται μαζί με τα υπόλοιπα οικιακά απορρίμματα μετά το τέλος του κύκλου ζωής του. Προκειμένου να αποφευχθούν ενδεχόμενες βλαβερές συνέπειες στο περιβάλλον ή την υγεία εξαιτίας της ανεξέλεγκτης διάθεσης απορριμμάτων, σας παρακαλούμε να το διαχωρίσετε από άλλους τύπους απορριμμάτων και να το ανακυκλώσετε, ώστε να βοηθήσετε στην βιώσιμη επαναχρησιμοποίηση των υλικών πόρων. Οι οικιακοί χρήστες θα πρέπει να έλθουν σε επικοινωνία είτε με τον πωλητή απ' όπου αγόρασαν αυτό το προϊόν, είτε τις κατά τόπους υπηρεσίες, προκειμένου να πληροφορηθούν τις λεπτομέρειες σχετικά με τον τόπο και τον τρόπο με τον οποίο μπορούν να δώσουν αυτό το προϊόν για ασφαλή προς το περιβάλλον ανακύκλωση. Οι επιχειρήσεις-χρήστες θα πρέπει να έλθουν σε επαφή με τον προμηθευτή τους και να ελέγξουν τους όρους και τις προϋποθέσεις του συμβολαίου πώλησης. Το προϊόν αυτό δεν θα πρέπει να αναμνηστεί με άλλα αναμνησμένα απορρίμματα προς διάθεση.

N

#### Korrekt avhending av dette produkt (Avfall elektrisk og elektronisk utstyr)



Denne merkingen som vises på produktet eller dens dokumentasjon, indikerer at den ikke skal kastes sammen med annet husholdningsavfall ved slutten av sin levetid. For å hindre mulig skade på miljøet eller menneskelig helse fra ukontrollert avfallsavhending, vennligst atskill dette fra andre typer avfall og resirkuler det ansvarlig for å fremme bærekraftig gjenbruk av materielle ressurser. Husholdningsbrukere bør kontakte enten forhandleren de kjøpte produktet av, eller lokale myndigheter, for detaljer om hvor og hvordan de kan frakte denne artikkelen for miljømessig trygg resirkulering. Forretningsbrukere bør kontakte sin leverandør og undersøke vilkårene i kjøpekontrakten. Dette produktet skal ikke blandes med annet kommersielt avfall som skal kastes.

(SLO)

**Ustrezno odstranjevanje tega izdelka** (odpadna električna in elektronska oprema)



Oznaka na izdelku ali spremljevalni dokumentaciji pomeni, da ga na koncu uporabne dobe ne smemo odstranjevati skupaj z drugimi gospodinjstskimi odpadki. Dá bi preprečili morebitno tveganje za okolje ali zdravje človeka zaradi nenadzorovanega odstranjevanja odpadkov, izdelek ločite od drugih vrst odpadkov in ga odgovorno reciklirajte t<sup>er</sup> tako spodbudite trajnostno ponovno uporabo materialnih virov. Uporabniki v gospodinjstvih naj za podrobnosti o t<sup>em</sup>, kam in kako lanko odnesejo ta izdelek na okolju varno recikliranje, pokličejo trgovino, kjer so izdelek kupili, ali lokalni vladni úrad. Podjetja naj pokličejo dobavitelja in preverijo pogoje nabavne pogodbe. Tega izdelka pri odstranjevanju ne smete mešati z drugimi gospodarskimi odpadki.

(IE)

**Diúscairt Cheart an Táirge Seo** (Trealamh Leictreach agus Leictreonach Dramhaiola)



Léiríonn an mharcáil seo atá ar an táirge nó sa litríocht a thagann leis, nár chóir é a dhíúscairt le dramháil tí eile ag deireadh a shaoil oibre. Chun cosaint i gcoinne dochar don chomhshaoil nó do shláinte an duine, a d'fhéadfadh bheith mar thoradh ar an ndíúscairt dramhaiola neamhtheoranta, scar an dramháil seo ó chineálacha eile dramhaiola le do thoil agus déan athchursáil fheargach air chun athúsáid inmharthana na hacmhainní ábhartha a chur chun cinn. Ba chóir dóibh siúd a úsáideann an trealamh sa bhaile dul i dteagmháil leis an dioltóir ónar cheannaigh siad an táirge seo, nó lena n-óifig áitiúil Rialtais, ar mhaithe le sonraí a fháil faoi cá háit agus cathain is féidir athchursáil atá slán ó thaobh an chomhshaoil de a dhéanamh ar an táirge seo. Ba chóir dóibh siúd a úsáideann an trealamh seo ina ngnó dul i dteagmháil leis an soláthróir agus téarmaí agus coinníollacha an chonartha ceannaigh a sheiceáil. Níor chóir an táirge seo a chur le dramháil eile tráchtála agus díúscairt á déanamh.

D

### EU-Konformitätserklärung

Wir, CYCLE PARTS GmbH, Grosse Ahlmuehle 33, D-76865 Rohrbach erklären, dass die VDO Fahrradcomputer mit Funkübertragung VDO Z1, Z2, Z3, Z2 PC-Link, Z3 PC-Link und alle Sender Z-CAD, Z-PULSE, Z-SENDER, Dockingstation bei bestimmungsgemäßer Verwendung den grundlegenden Anforderungen gemäß Artikel 3 der R&TTE-Richtlinie 1999/5/EG entsprechen. Die Konformitäts-Erklärung finden Sie unter [www.vdocyclecomputing.com](http://www.vdocyclecomputing.com).

GB

### EU-Declaration of Conformity

We, CYCLE PARTS GmbH, Grosse Ahlmuehle 33, D-76865 Rohrbach declare under our responsibility that the products VDO Z1, Z2,Z3,Z2 PC-Link, Z3 PC-Link and all transmitters Z-CAD, Z-PULSE, Z-SENDER, Dockingstation are compliant with the essential requirements and other relevant requirements of the R&TTE Directive (1999/5/EC). The declaration of Conformity can be found at [www.vdocyclecomputer.com](http://www.vdocyclecomputer.com).

Rohrbach, Februar 2008  
H.J. Noenen

**C** **€0682**

- CZ** Toto zařizení je v souladu se základními požadavky a ostatními odpovídajícími ustanoveními Směrnice 1999/5/EC.
- DK** Dette udstyr er i overensstemmelse med de væsentlige krav og andre relevante bestemmelser i Direktiv 1999/5/EF.
- EST** See seade vastab direktiivi 1999/5/EU ululistele nõuetele ja teistele asjakohastele sätetele.
- E** Este equipo cumple con los requisitos esenciales así como con otras disposiciones de la Directiva 1999/5/CE.
- GR** Αυτός ο εξοπλισμός είναι σε συμμόρφωση με τις ουσιαστικές απαιτήσεις και άλλες σχετικές διατάξεις της Οδηγίας 1999/5/ΕC.
- F** Cet appareil est conforme aux exigences essentielles et aux autres dispositions pertinentes de la Directive 1999/5/EC.
- IS** Þetta tæki er samkvæmt grunnkröfum og öðrum viðeigandi ákvæðum Tilskipunar 1999/5/EC.
- I** Questo apparato è conforme ai requisiti essenziali ed agli altri principi sanciti dalla Direttiva 1999/5/CE.
- LV** Šī iekārta atbilst Direktīvas 1999/5/EK būtiskajām prasībām un citiem ar to saistītajiem noteikumiem.
- LT** Šis įrenginys tenkina 1999/5/EB Direktyvos esminius reikalavimus ir kitas šios direktyvos nuostatas.
- NL** Dit apparaat voldoet aan de essentiële eisen en andere van toepassing zijnde bepalingen van de Richtlijn 1999/5/EC.
- M** Dan l-apparaat huwa konformi mal-ħtiġiet essenzjali u l-provedimenti l-oħra rilevanti tad-Direttiva 1999/5/EC.
- H** Ez a készülék teljesíti az alapvető követelményeket és más 1999/5/EC irányelvben meghatározott vonatkozó rendelkezéseket.
- N** Dette utstyret er i samsvar med de grunnleggende krav og andre relevante bestemmelser i EU-direktiv 1999/5/EF.
- PL** Urządzenie jest zgodne z ogólnymi wymaganiami oraz szczególnymi warunkami określonymi Dyrektywą UE: 1999/5/EC.
- P** Este equipamento está em conformidade com os requisitos essenciais e outras provisões relevantes da Directiva 1999/5/EC.
- SLO** Ta naprava je skladna z bistvenimi zahtevami in ostalimi relevantnimi pogoji Direktive 1999/5/EC.
- SK** Toto zariadenie je v zhode so základnými požiadavkami a inými príslušnými nariadeniami direktív: 1999/5/EC.
- FIN** Tämä laite täyttää direktiivin 1999/5/EY olennaiset vaatimukset ja on siinä asetettujen muiden laitetta koskevien määräysten mukainen.
- S** Denna utrustning är i överensstämmelse med de väsentliga kraven och andra relevanta bestämmelser i Direktiv 1999/5/EC.

USA

CDN

**ADDENDUM TO USER MANUAL**

FCC ID: TFO 66023

IC 5957A-66023

**CE0682**

Cycle Parts GmbH



**NOTICE:** This equipment has been tested and found to comply with the limits for a Class B digital device, pursuant to Part 15 of the FCC Rules. These limits are designed to provide reasonable protection against harmful interference in a residential installation. This equipment generates, uses and can radiate radio frequency energy and, if not installed and used in accordance with the instructions, may cause harmful interference to radio communications. However, there is no guarantee that interference will not occur in a particular installation. If this equipment does cause harmful interference to radio or television reception, which can be determined by turning the

equipment off and on, the user is encouraged to try to correct the interference by one or more of the following measures:

- Reorient or relocate the cycle computer head with the receiving antenna.
- Increase the separation between your equipment and the cycle computer head with the receiving antenna.
- Consult your bicycle dealer or an experienced radio/TV technician for help.

**NOTICE:** This device complies with Part 15 of the FCC Rules and with RSS-210 of Industry Canada.

Operation is subject to the following two conditions:

(1) this device may not cause harmful interference, and

(2) this device must accept any interference received, including interference that may cause undesired operation.

**NOTICE:** This Class B digital apparatus complies with Canadian ICES-003

**NOTICE:** Warning: Changes or modifications made to this equipment not expressly approved by VDO Cycle Parts GmbH may void the FCC authorization to operate this equipment.

**February 2008, Cycle Parts GmbH, Grosse Ahlmuehle 33, D-76865 Rohrbach, Germany**

USA

CDN

**ADDENDUM TO USER MANUAL**FCC ID: TFO 6604  
IC 5957A-6604**CE0682**

Cycle Parts GmbH



**NOTICE:** This equipment has been tested and found to comply with the limits for a Class B digital device, pursuant to Part 15 of the FCC Rules. These limits are designed to provide reasonable protection against harmful interference in a residential installation. This equipment generates, uses and can radiate radio frequency energy and, if not installed and used in accordance with the instructions, may cause harmful interference to radio communications. However, there is no guarantee that interference will not occur in a particular installation. If this equipment does cause harmful interference to radio or television reception, which can be determined by turning the

equipment off and on, the user is encouraged to try to correct the interference by one or more of the following measures:

- Reorient or relocate the cycle computer head with the receiving antenna.
- Increase the separation between your equipment and the cycle computer head with the receiving antenna.
- Consult your bicycle dealer or an experienced radio/TV technician for help.

**NOTICE:** This device complies with Part 15 of the FCC Rules and with RSS-210 of Industry Canada.

Operation is subject to the following two conditions:

- (1) this device may not cause harmful interference, and
- (2) this device must accept any interference received, including interference that may cause undesired operation.

**NOTICE:** This Class B digital apparatus complies with Canadian ICES-003

**NOTICE:** Warning: Changes or modifications made to this equipment not expressly approved by VDO Cycle Parts GmbH may void the FCC authorization to operate this equipment.

**February 2008, Cycle Parts GmbH, Grosse Ahlmuehle 33, D-76865 Rohrbach, Germany**

# VDO SERIES-Z

FOR RUNNING / HIKING



**VDO**  
CYCLECOMPUTING

[www.vdocyclecomputing.com](http://www.vdocyclecomputing.com)