



Tablet Controller Operating Manual
Manuel d'utilisation de la tablette de commande



disklavier™

Mark IV Series



disklavier™

Mark IV Series

English

Tablet Controller Operating Manual

Table of Contents

Chapter 1	Getting Started	3	
Items Supplied with the Disklavier.....	3	Preparing the Tablet Controller	6
Names of Parts and Their Functions	4		
Chapter 2	Basic Operations	8	
Operating the Tablet Controller.....	8	Turning the Disklavier Off (Standby Mode).....	12
Turning the Disklavier On	9	Shutting Down the Disklavier	13
Chapter 3	Basic Playback	15	
Playing Back the Sample Songs in the Song Library	15	Changing the Playback Tempo	24
Adjusting the Overall Volume	18	Playing Back Songs in a Different Key (Transposition)	25
Selecting a Song	19	Playing Back Only the Desired Piano Part	26
Searching Forward and Backward in a Song	21	Playing Back Songs with the Lyrics on the Screen.....	27
Selecting Directly the Different Song from the Current Album.....	22	Changing the Background of the Lyric Screen	28
Repeating Song Playback.....	23	Adjusting the Volume of the Microphone's Input and the Depth of it's Reverbration.....	30
Chapter 4	Basic Piano Playing	32	
Playing the Acoustic Piano (Acoustic Mode).....	32	Adjusting the Volume Balance among the Keyboard Playing, Ensemble Sound, Software Playback, and Microphone's Input.....	34
Playing the Digital Piano (Quiet Mode)	32		
Using Headphones (Headphone Mode)	33		
Chapter 5	Creating a Song Library	36	
Basic Operation on the File Manager	36	Copying Albums, Songs or the Entire Contents in a Source.....	44
Creating an Album in the Library	39	Deleting Albums, Songs and Play Lists	47
Renaming an Album, Song, or Play List	40	Rearranging the Order of Albums, Songs and Play Lists	49
Creating a New Play List.....	41	Erasing the Data in a Floppy Disk	51
Adding the Desired Song to Play List	43		
Chapter 6	Other Features	52	
Key Prompt Display during SmartKey™ Playback	52	Changing the Picture in the Frame	55
Display during Recording	52	Slide Show	57
Display during Playback of DisklavierRadio	53	Adding Images to the Picture Collection for the Frames in a Room (Background).....	58
Display during Using the IDC Service.....	53	Refreshing Contents in [From/To PC Folder]	59
Changing the Design of the Room (Background)	54		
Chapter 7	Function of the Configuration Bar	60	
Pairing the Tablet Controller and the Disklavier	60	Adjusting the Brightness of the Touch Screen	64
Restarting the Interface Screen	62	Setting the Time Zone.....	65
Adjusting the Volume of the Tablet Controller.....	63	Other Buttons	66
Chapter 8	Troubleshooting	67	

Getting Started

Items Supplied with the Disklavier

In addition to the items listed in “Items Supplied with the Disklavier” in “Advanced Operating Manual”, the items below are supplied with your Disklavier as well.

- Tablet Controller (1)
- Rechargeable batteries for Tablet Controller (1)
- Cradle for Tablet Controller (1)
- AC adaptor for Tablet Controller (1)
- AC power cord for Tablet Controller (1)
- Tablet Controller Operation manual (this book) (1)

Names of Parts and Their Functions

Tablet Controller

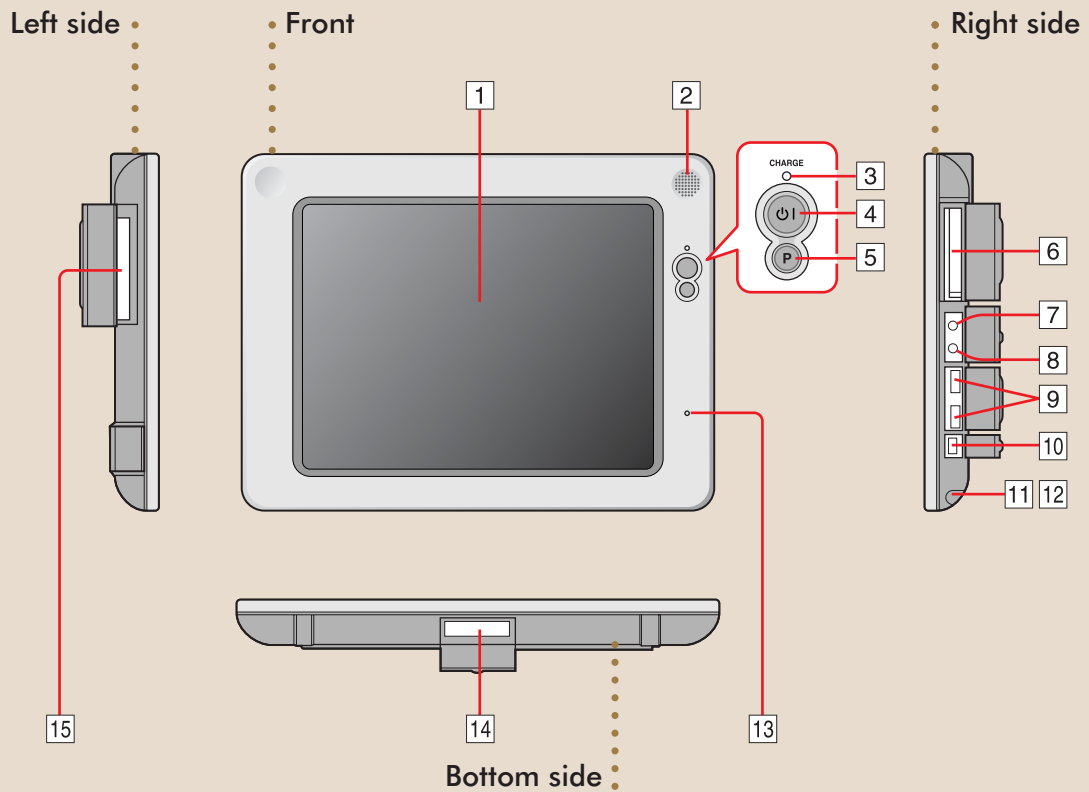

Cradle

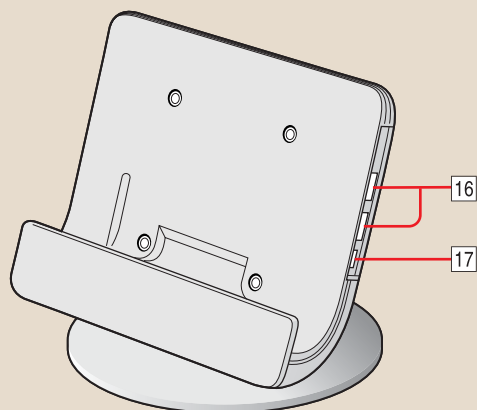

Tablet Controller

1	Touch screen	→ pg. 8 “Tapping with your fingers or the stylus pen”
2	Speaker	Outputs the sound of the Tablet Controller itself.
3	CHARGE lamp	Lights up orange when the Tablet Controller is being charged. Lights up green when the Tablet Controller is fully charged. Blinks red when the battery is almost empty.
4	⏻ (power button)/ Power lamp	Turns on the Tablet Controller. When this button is pressed while the Tablet Controller is on, the Power Management screen appears to shut down the system. / Lights up when the Tablet Controller is on.
5	P button	Shows the configuration bar. When this button is pressed while the configuration bar appears, the configuration bar is cleared.
6	CF card slot	For future use.
7	🎧 Headphone jack	For future use.
8	🎤 Microphone jack	For future use.
9	🔌 USB port	For future use.
10	⏻ 16V AC adaptor jack	Accepts the AC adaptor when the Tablet Controller is used without a cradle.
11	Stylus pen	For operating the touch screen.
12	Pen holder	Holds the stylus pen.
13	Microphone	For future use.
14	Cradle interface	Accepts the terminal on the cradle.
15	PC card slot	For future use.

Cradle

16	🔌 USB port	Same as 9.
17	⏻ 16V AC adaptor jack	Accepts the AC adaptor.

Preparing the Tablet Controller

1 Set up the cradle.

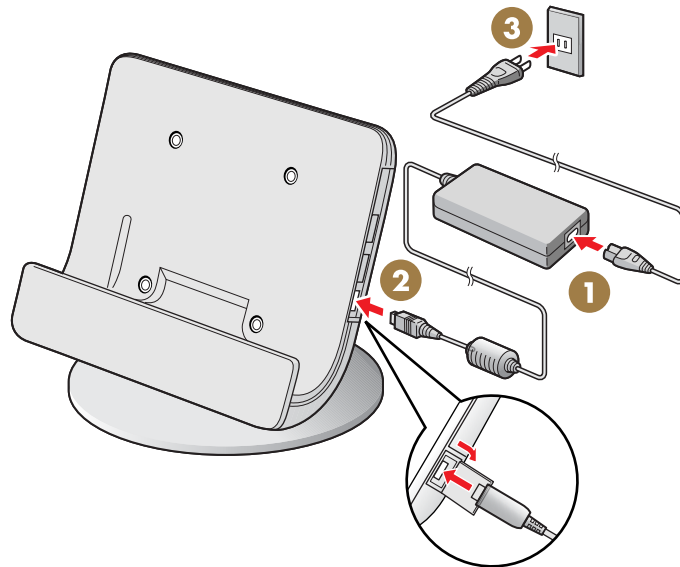

2 Put the rechargeable battery into the Tablet Controller.

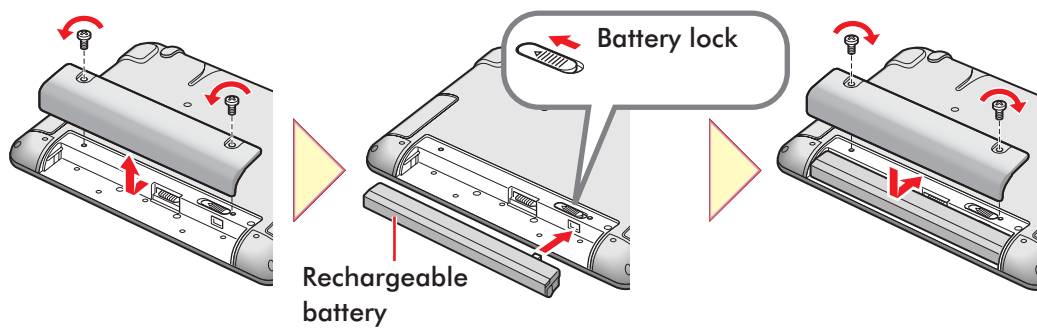

Tip: Before removing the battery, move the battery lock to the direction of an arrow.

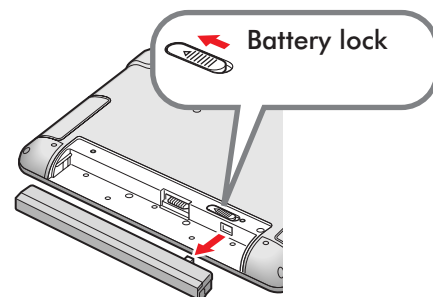

3 Open the cover of the cradle interface, and then set the Tablet Controller on the cradle.

Charging starts and the charge lamp lights in orange.

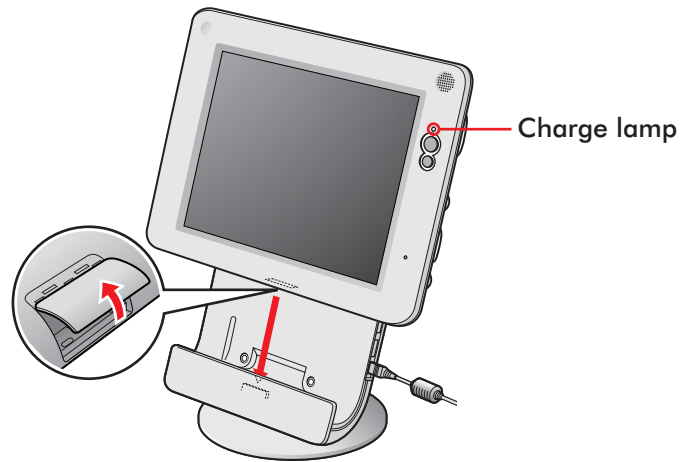

Adjusting the angle of the cradle to your preference

Loosen the two screws on the bottom of the base plate, adjust the angle, and then tighten the screws.

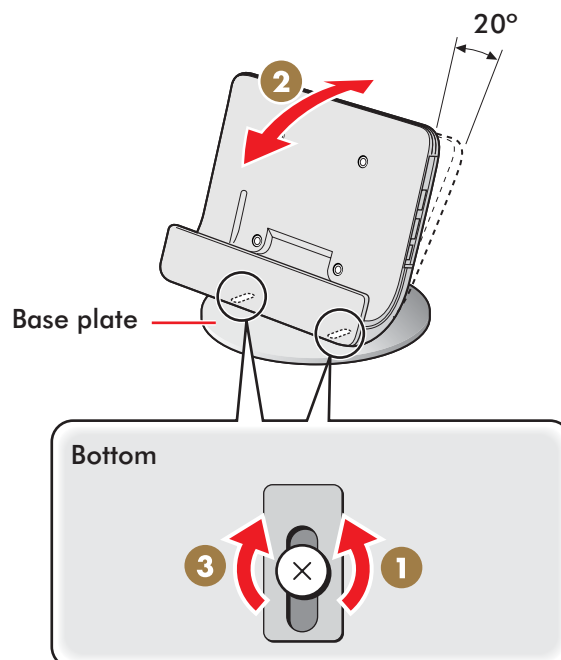

Basic Operations

◆ Before operating the Disklavier

Be sure to set up the Disklavier and the Tablet Controller. (→ pg. 11 “Setting Up the Disklavier” in Advanced Operating Manual)

Convention

In the following procedures, the buttons and controls are of the Tablet Controller unless otherwise noted.

Operating the Tablet Controller

You can operate the Tablet Controller by tapping items on the touch screen with your fingers. It is, however, recommended to use the supplied stylus pen to tap on a small point.

Tapping with your fingers or the stylus pen

Touch an item (application icon, button, control, etc.) on the touch screen once to execute its function.

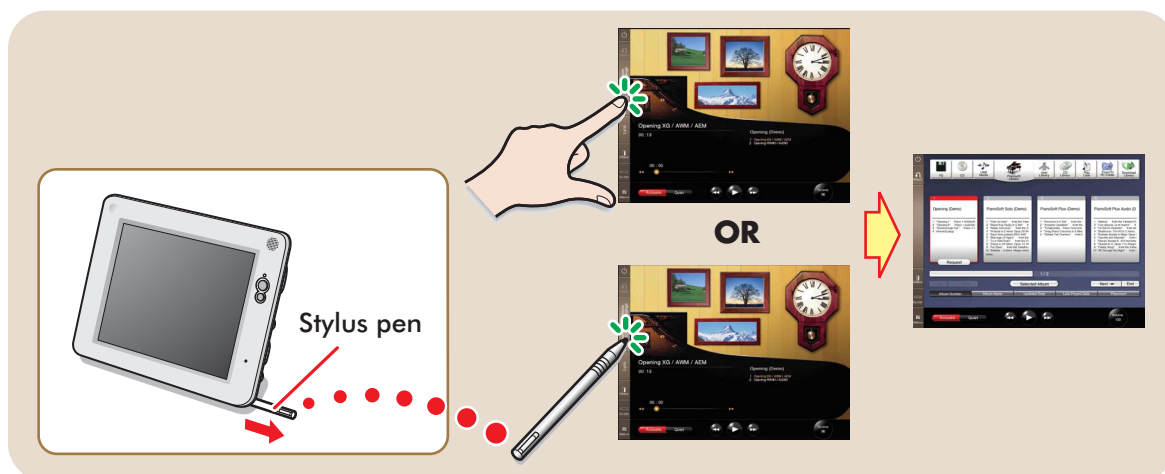

Turning the Disklavier On

1 Confirm that the power cable of the Power Supply unit is connected to an AC wall outlet.

2 Press the [ON] side of the [POWER] switch on the Monitor speakers. (→ pg. 10 in “Advanced Operating Manual”)

Note: This step is necessary only for models supplied with the Monitor speakers.

3 Press the [ON] side of the [MAINS] switch on the Power Supply unit. (→ pg. 5 in “Advanced Operating Manual”)

4 Press the [ON] side of the [MAINS] switch on the I/O Center. (→ pg. 4 in “Advanced Operating Manual”)

 on the Media Center starts flashing green.

Wait until  on the Media Center stops flashing and dimly lights green, and then go to step **5**.

Note: It may take several minutes.

5 Press (power button).

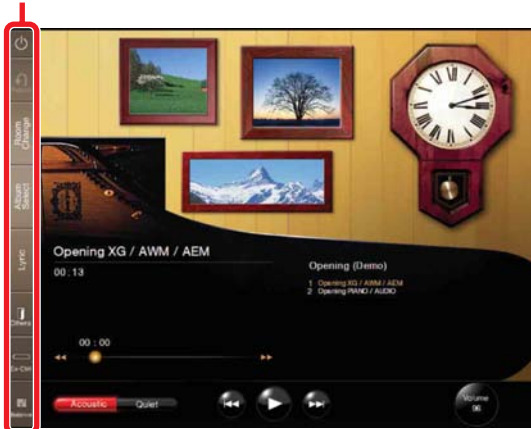

The Tablet Controller is turned on and the Play screen appears.

Function bar



Play screen

Note: This may take approximately two minutes. When turning the Disklavier back on after shutting down, be sure to wait 10 seconds before doing so.

Tip: Pressing  on the Media Center also turns the Disklavier on. In such a case, be sure to press  (power button) to turn on the Tablet Controller as well.

Note: After turning on the Tablet Controller for the first time, set up the Time Zone. For the procedure, → pg. 65 "Setting the Time Zone".

Note: In case the Disklavier and the Tablet Controller cannot connect in wireless, the following display appears.

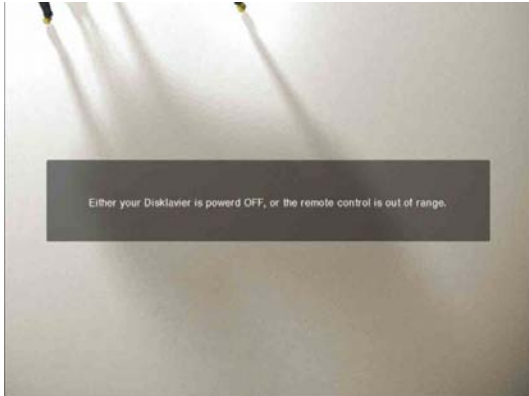

If this happens, either the Disklavier is turned off or the Tablet Controller is out of specified operation range.

Note: It takes several minutes to turn on the Disklavier. So if you turn on the Tablet Controller and the Disklavier at the same time, the above display may appear for a while. Once the Disklavier is turned on, the above display will be changed to the standby display automatically.

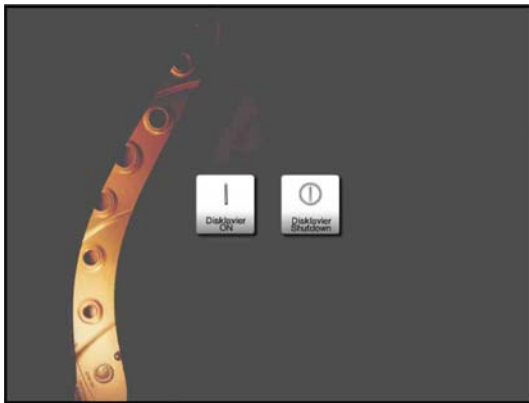

Standby display

Turning the Disklavier Off (Standby Mode)

After daily use, be sure to turn the Disklavier off by following the procedure below. In Standby mode, the piano is in effect turned off. However, electrically it is in a state in which a small quantity of power is being consumed.

1 Tap on  at the top of the Function bar.



2 Tap on .
  on the media center lights dimly green.
 The following screen appears.

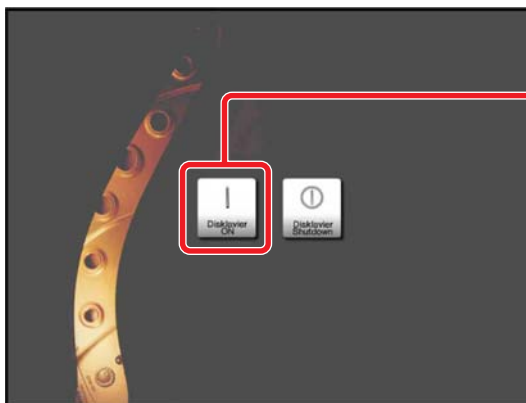

Tap to restart the Disklavier.

3 Tap on .
 The Disklavier turns off.

Shutting Down the Disklavier

Before disconnecting the power cable from the AC wall outlet, be sure to shut down the Disklavier by following the procedure below.

- 1 Tap on  at the top of the Function bar.



- 2 Tap on .



- 3 Tap on  to shut down the Disklavier.
 on the media center goes out.

4 Press (power button) to shut down the Tablet Controller.

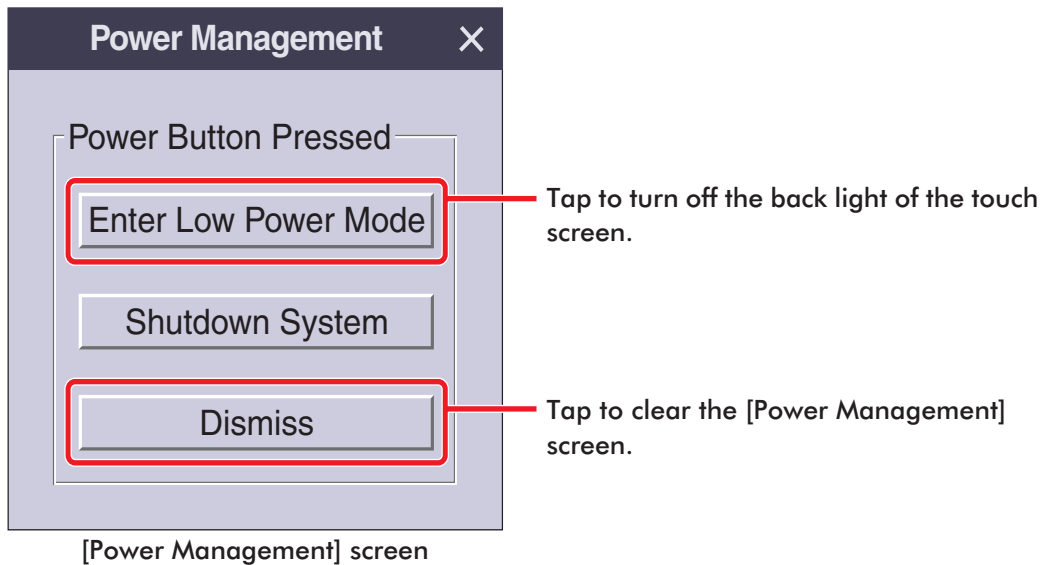

5 Tap on to shut down the Tablet Controller.

When turning the Disklavier back on, be sure to wait for 10 seconds before doing so.

◆ About the [MAINS] switches

The [MAINS] switches (on both the Power Supply unit and the I/O Center) only need to be switched off when you are not going to use the Disklavier for a long period of time. It is effectively the same as disconnecting the power cable from the AC wall outlet. For daily use, you can keep the [MAINS] switches on, and turn the Disklavier on and off by following the procedure "Turning the Disklavier Off (Standby Mode)" (→ pg. 12).

Basic Playback

Playing Back the Sample Songs in the Song Library

1 Turn the Disklavier on. (→ pg. 9 “Turning the Disklavier On”).

Function bar



Play screen

2 Tap on **Album Select** on the Function bar in the Play screen.



3 Tap on



Appears when there are more albums not shown in the screen. In such a case, move the slide bar to show the hidden albums.





Albums contained in the [Pianosoft Library]

Current page/Total page

Tap to show the page containing the selected album.

Appears when there are more albums not shown in the screen. In such a case, tap on  to show the next album. Tap on  to show the last album.

Appears when there are more albums not shown in the screen. In such a case, tap on  to show the previous album. Tap on  to show the first album.

4 Tap on the desired album.

The frame of the selected album will be displayed in red.



To select songs other than the first one in the album, tap on the desired album again, and then tap on the desired song. (→ pg. 22)

5 Tap on .



Selected song and elapsed playing time

Selected album and songs in the selected album

6 Tap on to start playback. will change to .



To pause playback, tap on .

 will change to .

To continue playback, tap on .

To select the next song, tap on .

To select the previous song, tap on .

Tip: When  is pressed while the last song of the album is played back, nothing happens. When  is pressed while the first song of the album is played back, nothing happens.

Adjusting the Overall Volume

- 1 Tap on  on the right bottom of a screen.



- 2 Drag the volume knob to adjust the volume.

The volume knob will disappear if you don't touch it for about 3 seconds.



Selecting a Song

- 1 When you play back a song on a floppy disk, a CD, or a USB medium, load the relevant medium into their respective drives or port on the Media Center. (→ pg. 2, 20 in “Advanced Operating Manual”)

Function bar



- 2 Tap on **Album Select** on the Function bar.



3 Tap on the desired source*.

* In this manual, we call each removable medium (floppy disk, CD, and USB flash memory, etc.) and the internal song library as a "source".

Appears when there are more albums not shown in the screen. In such a case, move the slide bar to show the hidden albums.

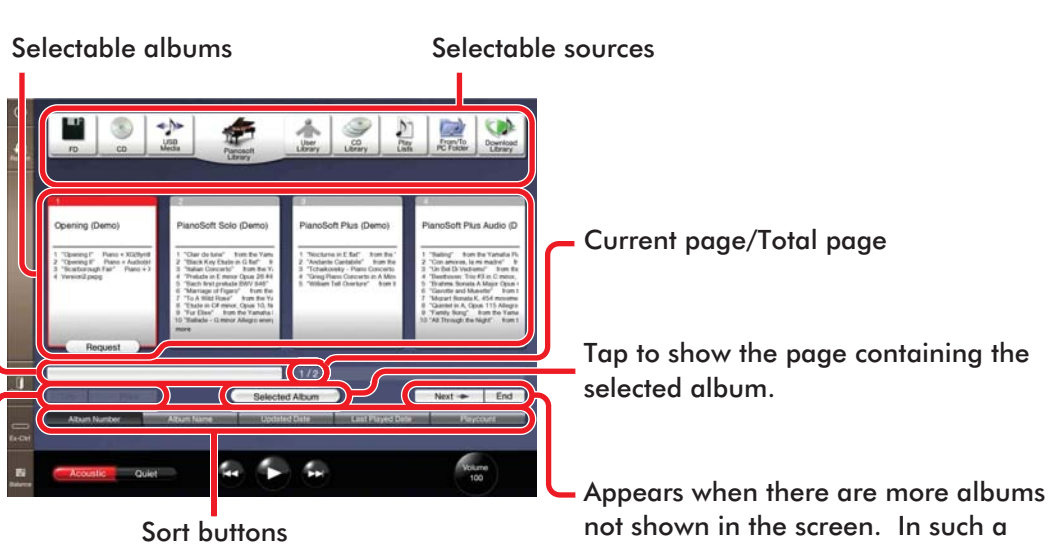

Appears when there are more albums not shown in the screen. In such a case, tap on **Prev** to show the previous album. Tap on **Top** to show the first album.

Current page/Total page

Tap to show the page containing the selected album.

Appears when there are more albums not shown in the screen. In such a case, tap on **Next** to show the next album. Tap on **End** to show the last album.

Tip: Pressing **User**, **PianoSoft**, **CD**, or **FD** on the Media Center also select the source, and then starts playback.

Tip: You can change the order of album on the screen by tapping on sort buttons.

- Album Number
- Album Name
- Updated Date
- Last Played Date
- Playcount

4 Tap on the desired album.

The frame of the selected album will be displayed red.



To select songs other than the first one, tap on the desired album again, and then tap on the desired song. (→ pg. 22)



To play the selected album from its first song, see step 5 – 6 on “Playing Back the Sample Songs in the Song Library”. (→ pg. 17)

Searching Forward and Backward in a Song

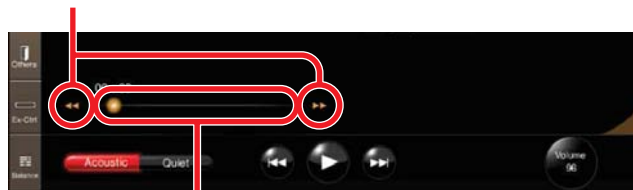
Forward/Backward button



Playback status bar

During playback or pausing, tap on  /  to locate the desired point. Tap on  to start playback.

During pausing, tap on  / , and then tap on the same button again to pause at the desired point.

Tip: Tapping on the desired point on the playback status bar starts playback from that point.

Selecting Directly the Different Song from the Current Album

You can specify the desired song to be played on the Play screen.

- 1 Playback the desired song. (→ pg. 19 “Selecting a Song”).**



Selected album and songs in the selected album

- 2 Tap on nearby the song list.**

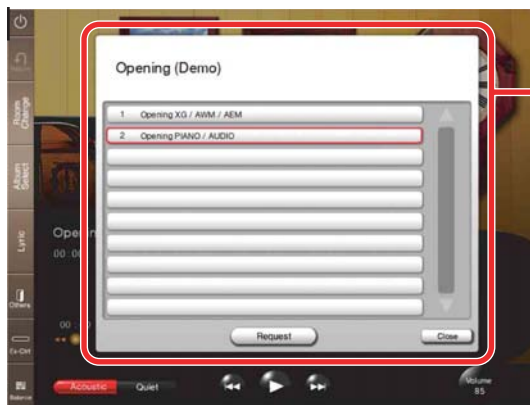

Song screen

- 3 Tap on the desired song, and then on .**
The desired song is selected.

Repeating Song Playback

1 Tap on on the Function bar.

The Ex-Ctrl (Extra control) bar appears on top center of the screen.



[Repeat] control buttons

Tip: You can move the Ex-ctrl bar wherever you want by dragging the right side of the bar.

2 Tap on / to select the desired repeat mode.

ALL: Repeats all songs in the current album.

ONE: Repeats the current song only.

RND: Repeats all songs in the current album in random order.

OFF: Cancels repeat setting.

3 Tap on after you finish setting to clear the bar.

To cancel the repeat mode, select OFF in step 2.

Tip: You can also clear the bar by tapping on  again.

Changing the Playback Tempo

This feature is useful, for example, when you listen to a complicated piano part with more care in slow tempo, and also when you practice a difficult piano part in slow tempo. You can change the tempo while the song is played back or stopped.

1 Select the desired song. (→ pg. 19 “Selecting a Song”)

2 Tap on  on the Function bar.

The Ex-Ctrl bar appears on top center of the screen.



[Tempo] control buttons

3 Tap on [Tempo]  /  to adjust the value.

To resume the original tempo, tap on [Tempo] .

Tip: The value can be adjusted from -50% to +20% in 1% increments.

4 Tap on  after you finish changing the tempo to clear the bar.

Tip: You can also clear the bar by tapping on .

Playing Back Songs in a Different Key (Transposition)

This feature is useful, for example, when you want to sing along in a key you are most comfortable with.

1 Select the desired song. (→ pg. 19 “Selecting a Song”)

2 Tap on  on the Function bar.
The Ex-Ctrl bar appears on top center of the screen.



[Transpose] control buttons

3 Tap on [Transpose]  /  to adjust the value.

To cancel the transposition, tap on [Transpose] .

Tip: The song can be temporarily transposed in half-step keys up or down two octaves (-24 to +24).

Note: Care must be taken when transposing songs on CDs, as increasing or decreasing the transposition value too much may have an adverse effect on sound quality.

4 Tap on  after you finish adjusting the value to clear the bar.

Tip: You can also clear the bar by tapping on .

Playing Back Only the Desired Piano Part

This could be useful, for example, when you listen to one part with more care, and also when you practice only the left- or right-hand part while the Disklavier plays the other.

1 Select the desired song. (→ pg. 19 “Selecting a Song”)

2 Tap on  on the Function bar.

The Ex-Ctrl bar appears on top center of the screen.



[Part Cancel] control buttons

3 Tap on  (left-hand part) /  (right-hand part) to play/mute the part.

Each time you tap on the part, its setting changes as follows showing the status with the color of the part icon:

Ex.: The setting of the left-hand part



Play

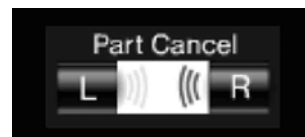

Mute

4 Tap on  after you finish selecting the part to clear the bar.

Tip: You can also clear the bar by tapping on .

Playing Back Songs with the Lyrics on the Screen

You can display the lyrics of songs played back. You can enjoy singing to your own Piano accompaniment and singing in Karaoke.

- 1 Tap on **Lyric** on the Function bar in the Play screen (→ pg. 10).



Lyric screen

- 2 Select the desired song. (→ pg. 19 "Selecting a Song")

3 Tap on .

Playback starts. The lyrics appear, and a color of the lyric changes as the song proceeds.

Note: The lyrics are not shown when a song does not include the lyric's data.

Note: When a song does not include the lyric's data, only a song title is shown.

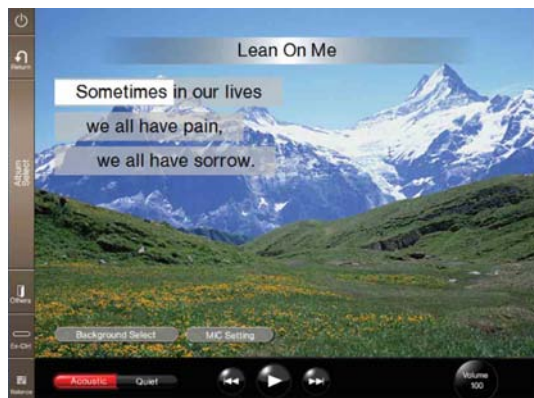

4 Tap on to return to the Play screen.

Note: For a user in North America, it is recommended to visit the website below to purchase songs with lyrics.

<http://www.yamahamusicsoft.com/>

For a user living in an area other than in North America, it is recommended to consult your dealer.

Changing the Background of the Lyric Screen

You can change the background of the Lyric Screen depending on your mood. You can select an image from the category such as Nature, Flowers, Vacation, World, Textures, Holiday, and Romantic.

- 1** Tap on **Lyric** on the Function bar in the Play screen (→ pg. 10).



Lyric screen

- 2** Tap on **Background Select** on the left bottom of the Lyric screen.

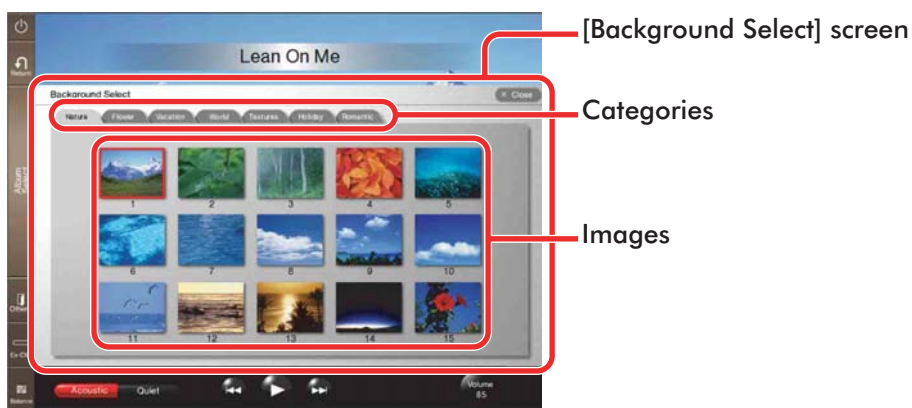

- 3** Tap on the desired category, and then the image.

- 4** Tap on **Close** to show the selected image as the background.

The [Background Select] screen is cleared.

Adjusting the Volume of the Microphone's Input and the Depth of its Reverbration

- 1 Tap on **Lyric** on the Function bar in the Play screen (→ pg. 10).



Lyric screen

- 2 Tap on **MIC Setting** on the left bottom of the Lyric screen.



[MIC Volume] bar

[Reverb Type] buttons

[Reverb Depth] bar

- 3** Tap on the desired point on the [MIC Volume] bar to adjust the volume of the Microphone's input.
- 4** Tap on the desired [Reverb Type] button, and then tap on the desired point on the [Reverb Depth] bar to adjust its depth.
- 5** Tap on . The [MIC Setting] screen is cleared.

Basic Piano Playing



The Disklavier is a versatile instrument offering various functions that integrate innovative technologies, but let's start with the most basic use of the piano: playing the keyboard.

Playing the Acoustic Piano (Acoustic Mode)

Play the keyboard as you would play any acoustic piano. You do not need to “turn the Disklavier on”.

Playing the Digital Piano (Quiet Mode)

Put the Disklavier in Quiet mode when you want to play the keyboard more quietly or more privately than on the acoustic piano. When Quiet Mode is activated, you are essentially playing the digital piano. Since the play sound is output through the Monitor speakers*, you can adjust the volume to your preference.

1 Turn the Disklavier on. (→ pg. 9 “Turning the Disklavier On”)



2 Tap on on the left bottom of a screen to engage the Quiet Mode.

The color of  turns to blue ().

Tip: Pressing  on the Media Center also engages the Quiet Mode.

3 Play the Disklavier.

You will hear the sound of the digital piano through the Monitor speakers*.

To disengage Quiet Mode, tap on  on left bottom of a screen. The color of  turns to red ().

Tip: Pressing  on the Media Center also inactivates the Quiet Mode.

* Only for models supplied with the Monitor speakers.

Using Headphones (Headphone Mode)

- 1 Turn the Disklavier on. (→ pg. 9 “Turning the Disklavier On”)
- 2 Connect the supplied stereo headphones to the PHONES jack on the bottom of the Media Center. (→ pg. 2 in “Advanced Operating Manual”)



appears.

Headphone mode indication

3 Play the Disklavier.

The Acoustic mode is silenced and the digital piano sound is heard only from the connected headphones.

Note: Two sets of headphones can be connected simultaneously. In this case, the two headphones should be of the same model.

Adjusting the Volume Balance among the Keyboard Playing, Ensemble Sound, Software Playback, and Microphone's Input

1 Tap on on the Function bar.



Balance control display

[Reset] button

Voice: Adjusts the volume of the digital piano sound* that you play on the Disklavier's keyboard in Quiet/Headphone mode. (→ pg. 32 "Playing the Digital Piano (Quiet Mode)")

* Note that this setting has no effect on the volume of the piano part pre-recorded on the software.

TG: Adjust the volume of the ensemble sound produced by the tone generator (TG) of the Disklavier.

Audio: Adjusts the volume of the accompaniment or standard audio sound pre-recorded on the software (CDs).

MIC: Adjusts the volume of the connected microphone.

2 Tap on the desired point on the volume bar of the desired sound to adjust its volume.

To reset the setting, tap on .

3 Tap on after you finish adjustment.

Balance control display is cleared.

Tip: You can also clear the Balance control display by tapping on .

Creating a Song Library

The following functions are useful for organizing the contents in the song libraries ([Pianosoft Library], [CD Library], [Download Library], [From/To PC Folder], and [User Library]) as well as the [Play Lists]. (→ pg. 25 “Utilizing the Play Lists” in “Advanced Operating Manual”.)

Basic Operation on the File Manager

This section explains how to select an album, song, or play list.

1 Tap on  on the Function bar.



2 Tap on  .
File Manager screen appears.

Finishes the file operation and returns to play screen.

[Source] buttons **[Album] list** **[Song] list**

Information area
Shows the selected source and details of the album or song.

File operation buttons
Once a source, album or song is selected, the available operation buttons are displayed.

Starts playing the selected song.

Tip: The File Manager screen shows the hierarchical directory structure of the Disklavier in an easy-to-understand appearance. You can intuitively select your desired song file or album.

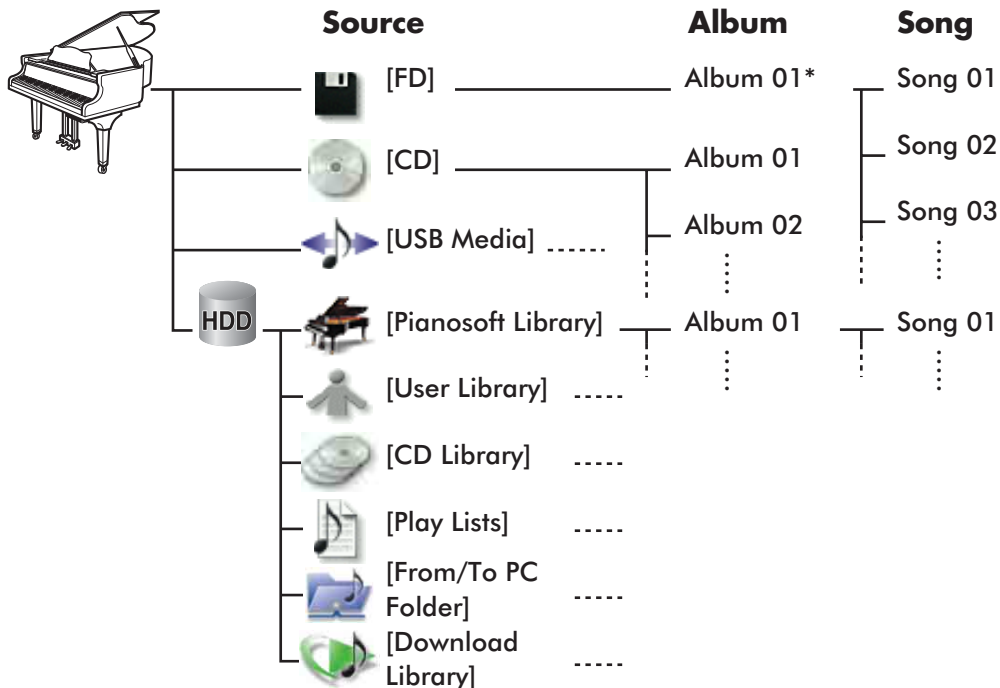

* The [FD] can contain only one album.

3 Tap on the desired source.

Ex: When [Pianosoft Library] is selected

The background of [Source] become pink.

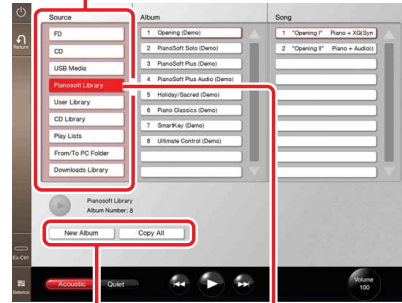

The available operation appears.

The selected source become red.

4 Tap on the desired album.

Ex: When [PianoSoft Solo (Demo)] is selected

The background of [Album] become pink.



The available operation appears.

The selected album become red.

5 Tap on the desired song.

Ex: When [Black Key Etude in G flat from...] is selected

The background of [Song] become pink.



The available operation appears.

The selected song become red.

Creating an Album in the Library

1 Select the desired source. (→ pg. 36.)

2 Tap on .



[New Album] screen



3 Tap on .



Software keyboard

4 Tap on each character for the name of the new album.

Note: The name must be within 64 characters.

5 Tap on  or .

The software keyboard is cleared.



6 Make sure the name is correct, and then tap on .

7 Make sure [Complete] appears, and then tap on .

Renaming an Album, Song, or Play List

1 Select the desired album, song, or play list. (→ pg. 36.)

2 Tap on .



The title of the selected album, song, or play list

3 Tap on .



Software keyboard

4 Tap on each character for the name of the new album.

Note: The name must be within 64 characters.

5 Tap on or .

The software keyboard is cleared.



6 Make sure the name is correct, and then tap on

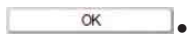

7 Make sure [Complete] appears, and then tap on .

Creating a New Play List

1 Tap on to select [Play Lists] as the source. (→ pg. 36.)

2 Tap on .

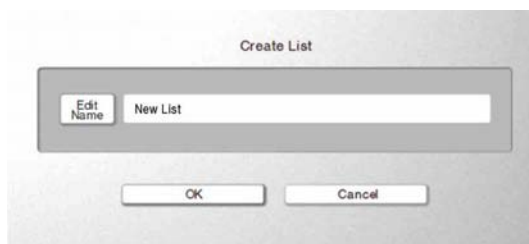

[Create List] screen

3 Tap on .



Software keyboard

4 Tap on each character for the name of the new Play List.

Note: The name must be within 64 characters.

5 Tap on  or .

The software keyboard is cleared.



6 Make sure the name is correct, and then tap on .

7 Make sure [Complete] appears, and then tap on .

Adding the Desired Song to Play List

1 Select the desired song. (→ pg. 36.)

2 Tap on .

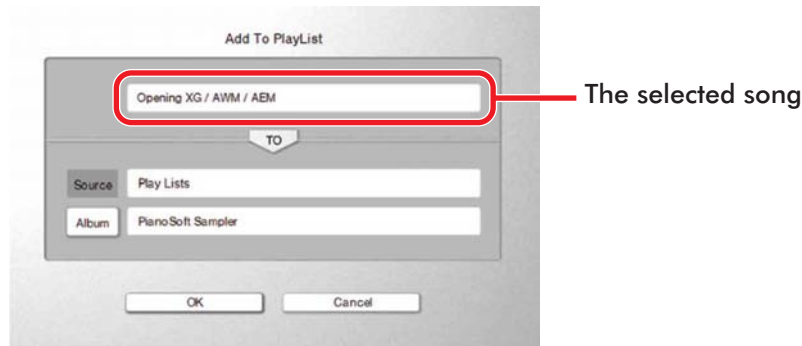

[Add to PlayList] screen

3 Tap on , and then on the desired album as a destination.

4 Tap on .

5 Make sure [Complete] appears, and then tap on .

Copying Albums, Songs or the Entire Contents in a Source

This function is available except for [CD Library] and [Play Lists].

1 Select the desired source, album or song. (→ pg. 36.)

2 Tap on one of the desired file operation buttons below:

: Selects the desired source to be copied

: Select the desired album to be copied.

: Select the desired song to be copied.

Note: The available file operation buttons differ depending on the selected contents.

The screen asking the destination appears.

Ex.: When you tap on



[Copy All] screen

Ex.: When you tap on

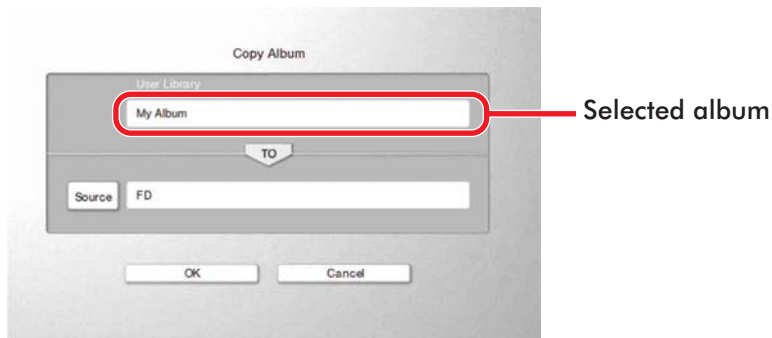

[Copy Album] screen

From now on, the procedure for coping a song is explained as an example.

Ex.: When you tap on

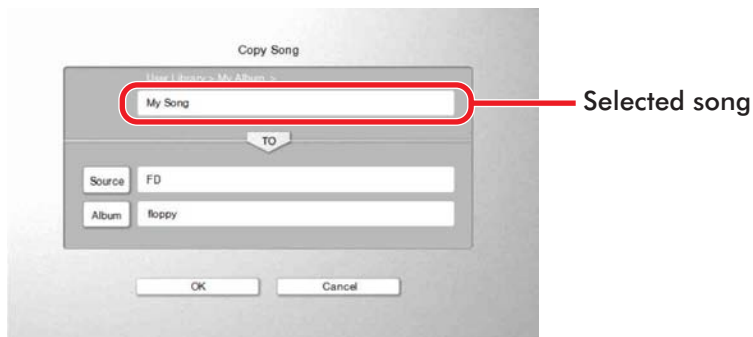

[Copy Song] screen

3 Tap on for destination source selection.



[Select Source] screen

4 Tap on the destination source, and then on . [Select Source] screen is cleared.

5 Tap on **Album** for destination album selection.

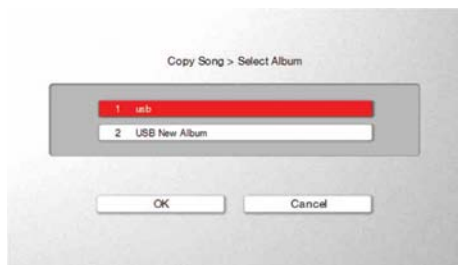

[Select Album] screen

6 Tap on the destination album, and then on **OK**.
[Select Album] screen is cleared.



Destination source and album

7 Make sure the destination is correct, and then tap on **OK**.

8 Make sure [Complete] appears, and then tap on **OK**.

Note: The contents of a source other than CD cannot be copied to [CD Library].

Deleting Albums, Songs and Play Lists

This function is available for all song libraries and [Play Lists].

1 Select the desired album, song, or play list. (→ pg. 36.)

2 Tap on one of the desired file operation buttons below:

: Delete the desired album

: Delete the desired song

: Delete the desired play list

: Delete the desired song on the desired play list

Ex.: When you tap on

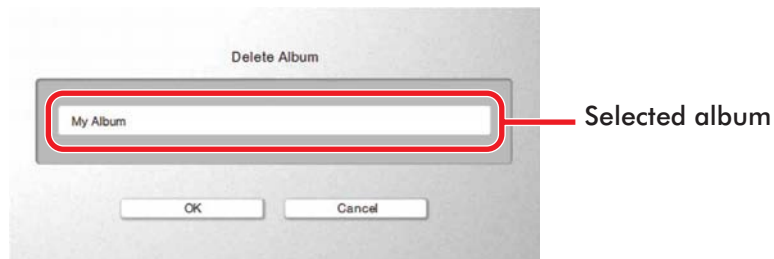

[Delete Album] screen

Ex.: When you tap on

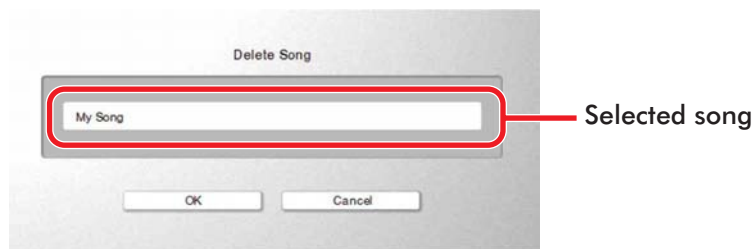

[Delete Song] screen

Ex.: When you tap on 

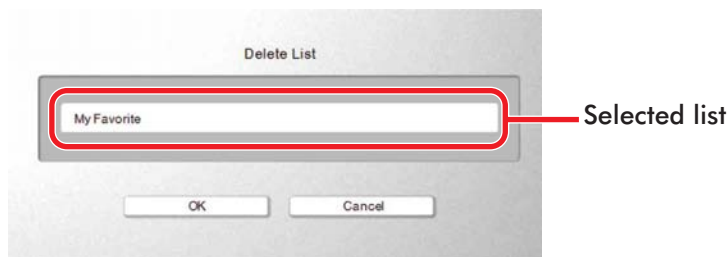

[Delete List] screen

Ex.: When you tap on 

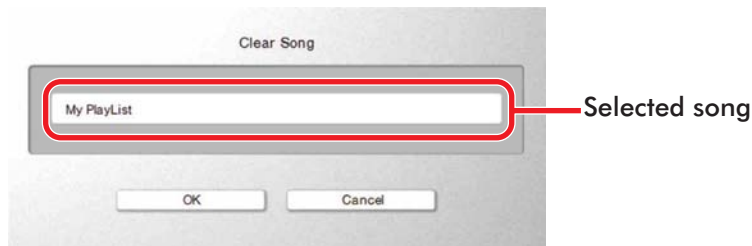

[Clear Song] screen

From now on, the procedure for deleting a song is explained as an example.

3 **Make sure it is all right to delete it, and then tap on**
.

4 **Make sure [Complete] appears, and then tap on**
.

Tip: Even if you delete a play list or song of the play list, the original song file cannot be deleted.

Rearranging the Order of Albums, Songs and Play Lists

This function is available for all libraries and [Play Lists].

1 Select the desired album, song or play list. (→ pg. 36.)

2 Tap on one of the desired file operation buttons below:

: Rearrange the order of albums

: Rearrange the order of songs

Ex.: When you tap on

The selected album

Rearranging buttons

: Moves the album to the top of the source.

: Moves the album downward.

: Moves the album upward.

: Moves the album to the end of the source.

The destination

[Sort Album] screen

Ex.: When you tap on

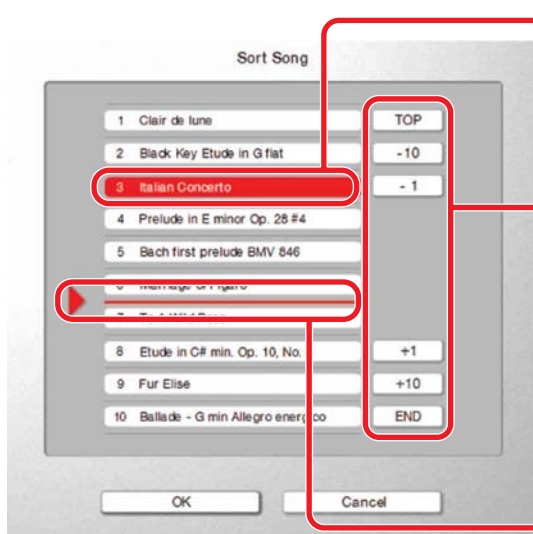

The selected song

Rearranging buttons

: Moves the song to the top of the album.

: Moves the song downward.

: Moves the song upward.

: Moves the song to the end of the album.

The destination

[Sort Song] screen

3 Tap on the rearranging button to move the selected album or song to the desired position, and then on

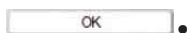

4 Make sure [Complete] appears, and then tap on .

Erasing the Data in a Floppy Disk

Make sure that the floppy disk is already formatted.

1 Tap on . (→ pg. 36.)

2 Tap on .



[Delete All] screen

3 Tap on .

Note: Before tapping on , make sure it is all right to delete the contents.

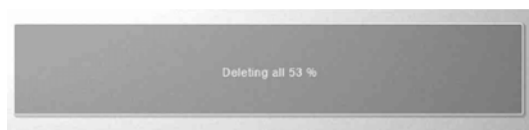

Note: DO NOT turn off the Disklavier or eject the floppy disk while the deletion is in progress.

4 Tap on .

Other Features



Key Prompt Display during SmartKey™ Playback

See pg. 35 “SmartKey™ Playback” in “Advanced Operating Manual” for details.



Key prompt is shown here.

Display during Recording

While recording, the following display appears.



Note: While this screen appears, the Disklavier cannot be controlled by the Tablet Controller.

Display during Playback of DisklavierRadio

While playing back DisklavierRadio, the following display appears.

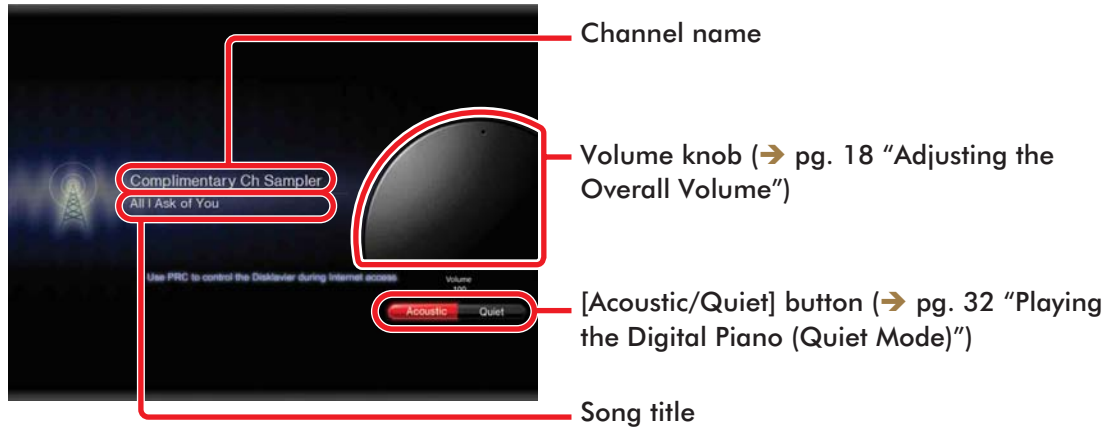

Display during Using the IDC Service

While connecting the Disklavier to the IDC service, the following display appears and operations on the Tablet Controller are disabled.*

* Except for during DisklavierRadio playback.



Changing the Design of the Room (Background)

You can change the design of the room (background) depending on your mood.

1 Tap on  on the Function bar in the Play screen (→ pg. 10).

Every time you tap on it, the design of the room changes as follows:



Room 1



Room 2

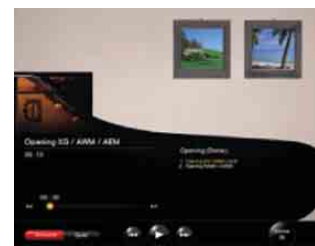

Room 3



Room 6

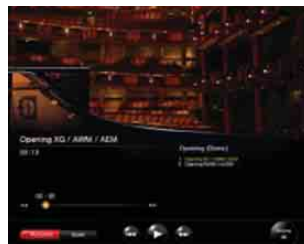

Room 5



Room 4

Tip: You can change a picture in a frame on the wall of the room.
(→ pg. 55 “Changing the Picture in the Frame”)

Note: The design and the number of the Rooms are subject to change without notice.

Changing the Picture in the Frame

You can change, move, zoom in or out the picture in the frame on the Room (background).

(This is limited to only the design with a picture in a frame.)

1 Tap on on the Function bar.

Select the scene you want to go.

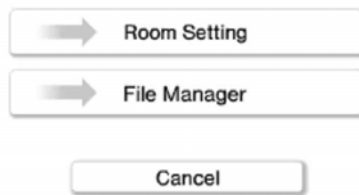

2 Tap on .



3 Tap on the frame in which you want to change the picture.

The inside of the frame turns to red.

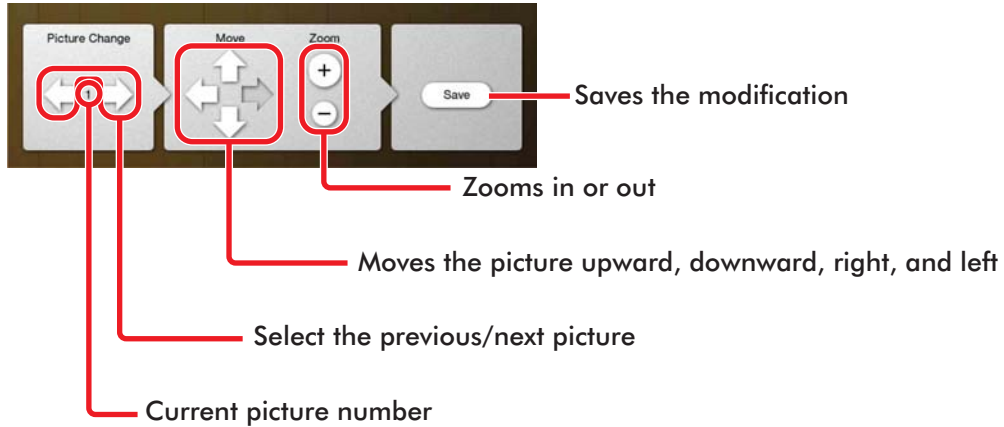

Tip: You can add your favorite pictures as options for the frame. See pg. 58 for details.

4 Tap on the arrows or \oplus/\ominus to modify the picture in the selected frame.

5 Tap on .

The changed design is saved.

Tip: When you want to change the picture in another room, tap on to select the desired room, and then start from step 1.

To return to the Play screen, tap on .

Slide Show

You can enjoy a slide show using pictures saved in My Picture folder. (→ pg. 58)

1 Tap on a picture in a frame.



A picture saved in My Picture folder is displayed in turn in the whole area of a screen.



2 Tap on a screen during a slide show.

The slide show finishes, and then the screen returns to the Play screen.

Adding Images to the Picture Collection for the Frames in a Room (Background)

You can replace the picture in a frame at the shipment with your favorite ones by adding the pictures to the picture collection. Furthermore, the added pictures are used for the slide show (→ pg. 57).

1 Connect the I/O Center to a LAN (local area network) to which a Windows PC with a picture data is also connected.

Note: It is necessary that I/O center can get IP address as a DHCP client.

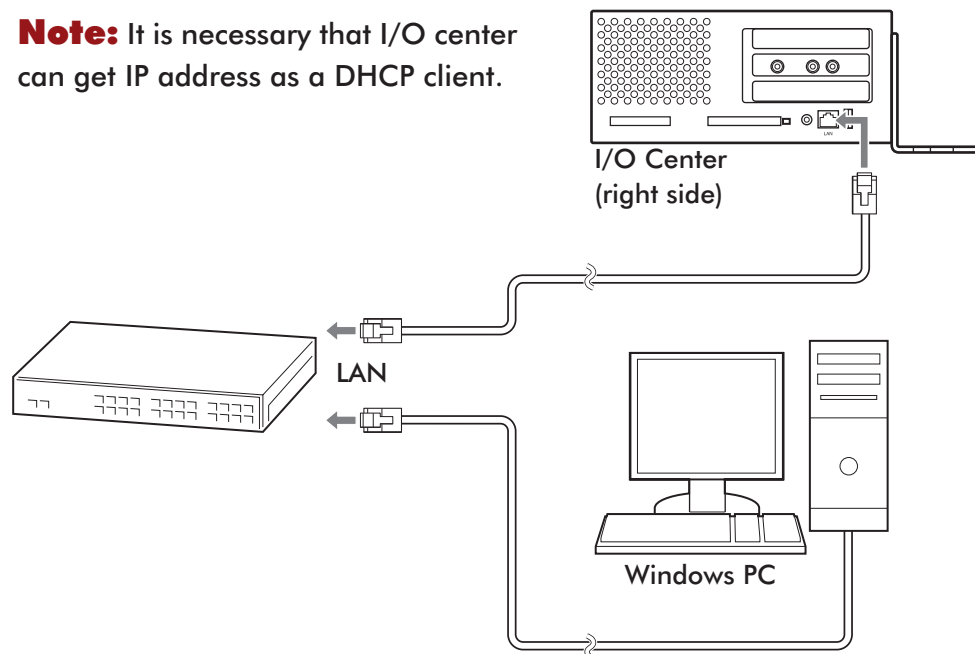

2 Start up Explore, and then open [My Network Places] on the PC.

Tip: Make sure that the Disklavier is on, and then start up Explore.

3 Open [Dkv*****]* and confirm that [My Picture] is shown under that.

* [*****] differs depending on the model.

4 Copy your favorite images to [My Picture].

Note: Only the JPEG files are available for this function. The extension should be ".jpeg", ".jpg", ".jpe", ".JPEG", ".JPG" or ".JPE".

Note: The recommended solution of the image file is 800 x 600 pixels or lower. In case a solution of the image file is more than the size recommended above, it may take more time to show the entire image.

Refreshing Contents in [From/To PC Folder]

1 Perform step 1 – 2 in "Selecting a Song". (→ pg. 19)

2 Tap on .



3 Tap on .

Note: For details on copying song files to [From/To PC Folder], refer to "Copying Song File from a Personal Computer to the Disklavier" on pg. 37 in "Advanced Operating Manual".

Function of the Configuration Bar

Pairing the Tablet Controller and the Disklavier

When purchased, this setting is already done. So you don't have to perform the following procedure.

Note: Before making this setting, you are recommended to turn off all wireless appliances other than the Disklavier.

1 Press  (**P button**).



Configuration bar

2 Tap on .



3 Tap on .



[Message Box] screen

4 Tap on .

The program starts searching for the Disklavier.



Tip: ***** differs depending on the model.

5 Tap on .

The setting is saved, and the following message appears.

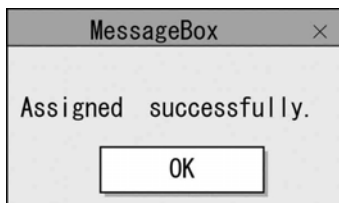

6 Tap on .

Now you can use the Tablet Controller as a remote controller of the Disklavier.

Note: If the following message appears, the Tablet Controller may be connected to another wireless appliance, or the Disklavier may not be turned on. In this case, turn on the Disklavier, turn off all other wireless appliances, and perform the procedure from step 1 again while standing near the Disklavier.



Restarting the Interface Screen

If the Tablet Controller malfunctions, or does not respond, restart the interface screen.

1 Press  (P button).

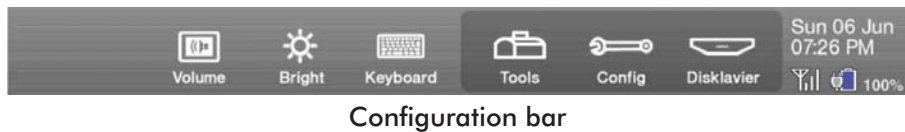

2 Tap on .



3 Tap on .

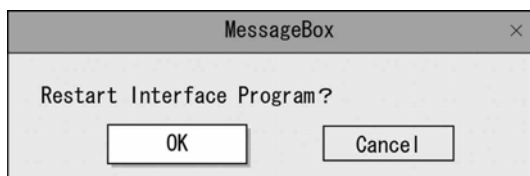

4 Tap on .

The interface screen closes, and then restarts.

Adjusting the Volume of the Tablet Controller

You can adjust the volume of the Tablet Controller.

1 Press  (P button).



Configuration bar

2 Tap on .

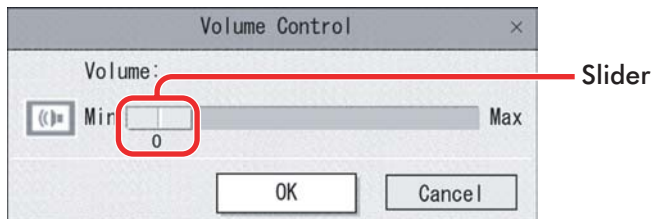

3 Drag the slider to adjust the volume, and then tap on .

Adjusting the Brightness of the Touch Screen

1 Press  (P button).



Configuration bar

2 Tap on .

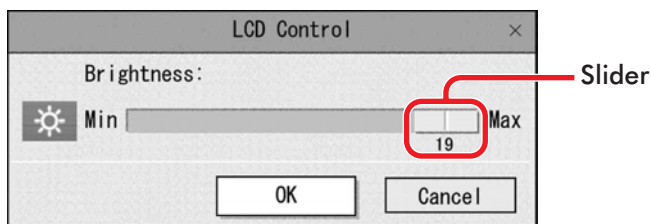

3 Drag the slider to adjust the Brightness, and then tap on .

Setting the Time Zone

1 Press  (P button).



Configuration bar

2 Tap on .

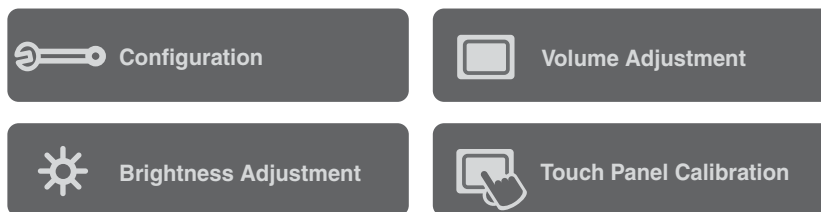

3 Tap on .

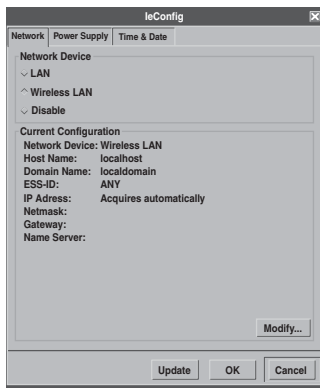

4 Tap on  tab.

5 Tap on [Time Zone] , and then on your time zone in the drop down list.

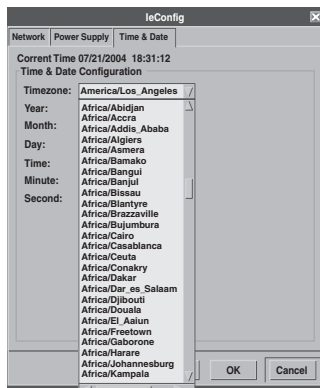

6 Tap on  .



7 Tap on  .

Other Buttons

Other buttons such as  and  on the configuration bar are not generally used.

Troubleshooting

If you have problems operating the Disklavier, see if any of the symptoms listed below apply to your problem and follow the recommended remedy.

You cannot turn on the Tablet Controller.	<ul style="list-style-type: none">• Make sure the Tablet Controller contains batteries.• Make sure the Tablet Controller is charged.• If the Tablet Controller is broken, consult your Disklavier dealer.
You cannot operate the Tablet Controller.	<p>The Tablet Controller and the Disklavier do not connect in a wireless environment.</p> <ul style="list-style-type: none">• Make sure the Tablet Controller is within the specified operating range. (Make sure you are using the Tablet Controller in a close range to the Disklavier.) If the Tablet Controller still does not connect to the Disklavier, the Tablet Controller may be broken. Consult your Disklavier dealer.• Make sure that the Disklavier is turned on. If the problem continues, consult your Disklavier dealer.
The Tablet Controller does not respond even when you press the buttons.	<ul style="list-style-type: none">• Restart the interface screen. (→ pg. 62)• When interface restarting does not solve the problem, press the Power button on the Tablet Controller for 4 seconds. This will force the Tablet Controller to shut down.
You cannot shut down the Tablet Controller.	<ul style="list-style-type: none">• Press the Power button on the Tablet Controller for 4 seconds. This will force the Tablet Controller to shut down.

Contains Macromedia® Flash™ Player technology by Macromedia, Inc., Copyright © 1995-2004 Macromedia, Inc. All rights reserved. Macromedia, Flash and Macromedia Flash are trademarks or registered trademarks of Macromedia, Inc. in the United States and internationally.



"This product features the Macromedia® Flash™ Player technology. For further information on the Macromedia Flash Player, visit <http://www.macromedia.com/software/flash/about/>."



YAMAHA CORPORATION

P.O.Box 3, Hamamatsu, 430-8651 Japan

Copyright © 2004 by Yamaha Corporation
This document is printed on chlorine free (ECF) paper.



For U.S.A.

**COMPLIANCE INFORMATION STATEMENT
(DECLARATION OF CONFORMITY PROCEDURE)**

Responsible Party : Yamaha Corporation of America
Address : 6600 Orangethorpe Avenue, Buena Park, CA 90620 USA
Telephone : 1-714-522-9011
Fax : 1-714-522-9301
Type of Equipment : Tablet Controller
Model Name : TRC-100

These devices complies with Part 15 of the FCC Rules.

Operation is subjected to the following conditions;

- 1) this device may not cause harmful interference, and
 - 2) this device must accept any interference received including interference that may cause undesired operation.
- See user manual instructions if interference to radio reception is suspected.

FCC INFORMATION (U.S.A.)

1. IMPORTANT NOTICE: DO NOT MODIFY THIS UNIT!

This product, when installed as indicated in the instructions contained in this manual, meets FCC requirements. Modifications not expressly approved by Yamaha may void your authority, granted by the FCC, to use the product.

2. IMPORTANT: When connecting this product to accessories and/or another product use only high quality shielded cables.

Cable/s supplied with this product **MUST** be used. Follow all installation instructions. Failure to follow instructions could void your FCC authorization to use to use this product in the USA.

3. NOTE: This product has been tested and found to comply with the requirements listed in FCC Regulations, Part 15 for Class "B" digital devices. Compliance with these requirements provides a reasonable level of assurance that your use of this product in a residential environment will not result in harmful interference with other electronic devices. This requirement generates/uses radio frequencies and, if not installed and used according to the instructions found in the users manual, may cause interference harmful to the operation of other electronic devices.

Compliance with FCC regulations does not guarantee that interference will not occur in all installations. If this product is found to be the source of interference, which can be determined by turning the unit "OFF" and "ON", please try to eliminate the problem by using one of the following measures: Relocate either this product or the device that is being affected by the interference.

Utilize power outlets that are on different branch (circuit breaker or fuse) circuits or install AC line filter/s.

In the case of radio or TV interference, relocate/reorient the antenna. If the antenna lead-in is 300 ohm ribbon lead, change the lead-in to coaxial type cable.

If these corrective measures do not produce satisfactory results, please contact the local retailer authorized to distribute this type of product. If you can not locate the appropriate retailer, please contact Yamaha Corporation of America, Electronic Service Division, 6600 Orangethorpe Ave, Buena Park, CA 90620.

For U.S.A.

The Tablet Controller contains a small amount of mercury. Disposal of this material may be regulated due to environmental considerations.

For disposal information in the United States, refer to the Electronic Industries Alliance web site: www.eiae.org

This applies only to products distributed by Yamaha Corporation of America.

For U.S.A.

This product contains a battery that contains perchlorate material. Perchlorate Material-special handling may apply.

See www.dtsc.ca.gov/hazardouswaste/perchlorate