



YAMAHA 2001

FJR1300(N)

5JW1-AE1

SERVICE MANUAL



YAMAHA

FJR1300R

5JW9-AE1

5JW-28197-20

SERVICE MANUAL

NOTICE

This manual was produced by the Yamaha Motor Company, Ltd. primarily for use by Yamaha dealers and their qualified mechanics. It is not possible to include all the knowledge of a mechanic in one manual. Therefore, anyone who uses this book to perform maintenance and repairs on Yamaha vehicles should have a basic understanding of mechanics and the techniques to repair these types of vehicles. Repair and maintenance work attempted by anyone without this knowledge is likely to render the vehicle unsafe and unfit for use.

Yamaha Motor Company, Ltd. is continually striving to improve all of its models. Modifications and significant changes in specifications or procedures will be forwarded to all authorized Yamaha dealers and will appear in future editions of this manual where applicable.

NOTE:

Designs and specifications are subject to change without notice.

IMPORTANT MANUAL INFORMATION

Particularly important information is distinguished in this manual by the following.



The Safety Alert Symbol means ATTENTION! BECOME ALERT! YOUR SAFETY IS INVOLVED!

WARNING

Failure to follow WARNING instructions could result in severe injury or death to the motorcycle operator, a bystander or a person checking or repairing the motorcycle.

CAUTION:

A CAUTION indicates special precautions that must be taken to avoid damage to the motorcycle.

NOTE:

A NOTE provides key information to make procedures easier or clearer.

HOW TO USE THIS MANUAL

This manual is intended as a handy, easy-to-read reference book for the mechanic. Comprehensive explanations of all installation, removal, disassembly, assembly, repair and check procedures are laid out with the individual steps in sequential order.

- ① The manual is divided into chapters. An abbreviation and symbol in the upper right corner of each page indicate the current chapter.
Refer to "SYMBOLS".
- ② Each chapter is divided into sections. The current section title is shown at the top of each page, except in chapter 3 ("PERIODIC CHECKS AND ADJUSTMENTS"), where the sub-section title(s) appears.
- ③ Sub-section titles appear in smaller print than the section title.
- ④ To help identify parts and clarify procedure steps, there are exploded diagrams at the start of each removal and disassembly section.
- ⑤ Numbers are given in the order of the jobs in the exploded diagram. A circled number indicates a disassembly step.
- ⑥ Symbols indicate parts to be lubricated or replaced.
Refer to "SYMBOLS".
- ⑦ A job instruction chart accompanies the exploded diagram, providing the order of jobs, names of parts, notes in jobs, etc.
- ⑧ Jobs requiring more information (such as special tools and technical data) are described sequentially.

②

CLUTCH

①

ENG

④

CLUTCH

CLUTCH COVER

⑤

Order	Job/Part	Qty	Remarks
Removing the clutch cover			
	Right side cowling		Refer to "COWLINGS AND COVERS" in chapter 3.
	Engine oil		Drain. Refer to "CHANGING THE ENGINE OIL" in chapter 3.
1	Clutch cover	1	
2	Clutch cover gasket	1	
3	Dowel pin	2	
4	Damper cover	1	
5	Damper	1	
For installation, reverse the removal procedure.			

⑦

CLUTCH

ENG

③

REMOVING THE CLUTCH

- Remove:
 - rear balancer weight

Refer to "BALANCERS".
- Remove:
 - clutch cover ①

NOTE:
Loosen each bolt 1/4 of a turn at a time, in stages and in a crisscross pattern. After all of the bolts are fully loosened, remove them.
- Straighten the lock washer tab.
- Loosen:
 - clutch boss nut ①

NOTE:
While holding the clutch boss ② with the universal clutch holder ③, loosen the clutch boss nut.

Universal clutch holder
90890-04086















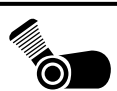

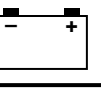





⑧

- Remove:
 - clutch boss nut ①
 - lock washer ②
 - clutch boss assembly ③

NOTE:
There is a built-in damper between the clutch boss and the clutch plate. It is not necessary to remove the wire circlip ④ and disassemble the built-in damper unless there is serious clutch chattering.

5 - 45

5 - 48

① GEN INFO 	② SPEC 	
③ CHK ADJ 	④ CHAS 	
⑤ ENG 	⑥ COOL 	
⑦ FI 	⑧ ELEC 	
⑨ TRBL SHTG ? 	⑩ 	
⑪ 	⑫ 	
⑬ 	⑭ 	
⑮ 	⑯ 	⑰ 
⑱ 	⑲ 	⑳ 
㉑ 	㉒ 	㉓ 
㉔ 	㉕ New	

EAS00008

SYMBOLS

The following symbols are not relevant to every vehicle.

Symbols ① to ⑨ indicate the subject of each chapter.

- ① General information
- ② Specifications
- ③ Periodic checks and adjustments
- ④ Chassis
- ⑤ Engine
- ⑥ Cooling system
- ⑦ Fuel injection system
- ⑧ Electrical system
- ⑨ Troubleshooting

Symbols ⑩ to ⑰ indicate the following.

- ⑩ Serviceable with engine mounted
- ⑪ Filling fluid
- ⑫ Lubricant
- ⑬ Special tool
- ⑭ Tightening torque
- ⑮ Wear limit, clearance
- ⑯ Engine speed
- ⑰ Electrical data









Symbols ⑱ to ㉓ in the exploded diagrams indicate the types of lubricants and lubrication points.

- ⑱ Engine oil
- ⑲ Gear oil
- ⑳ Molybdenum disulfide oil
- ㉑ Wheel bearing grease
- ㉒ Lithium soap base grease
- ㉓ Molybdenum disulfide grease

Symbols ㉔ to ㉕ in the exploded diagrams indicate the following.

- ㉔ Apply locking agent (LOCTITE®)
- ㉕ Replace the part

TABLE OF CONTENTS

GENERAL INFORMATION	
	GEN INFO 1
SPECIFICATIONS	
	SPEC 2
PERIODIC CHECKS AND ADJUSTMENTS	
	CHK ADJ 3
CHASSIS	
	CHAS 4
ENGINE	
	ENG 5
COOLING SYSTEM	
	COOL 6
FUEL INJECTION SYSTEM	
	FI 7
ELECTRICAL SYSTEM	
	ELEC 8
TROUBLESHOOTING	
	TRBL SHTG 9

Notice: This enhanced version has been prepared for persons who already own a copy of the FJR Service Manual. The enhancements are distributed as freeware for the FJR Owner's community. If you find them useful, please donate 5 or 10 units of your local currency to a motorcycle charity or related event.

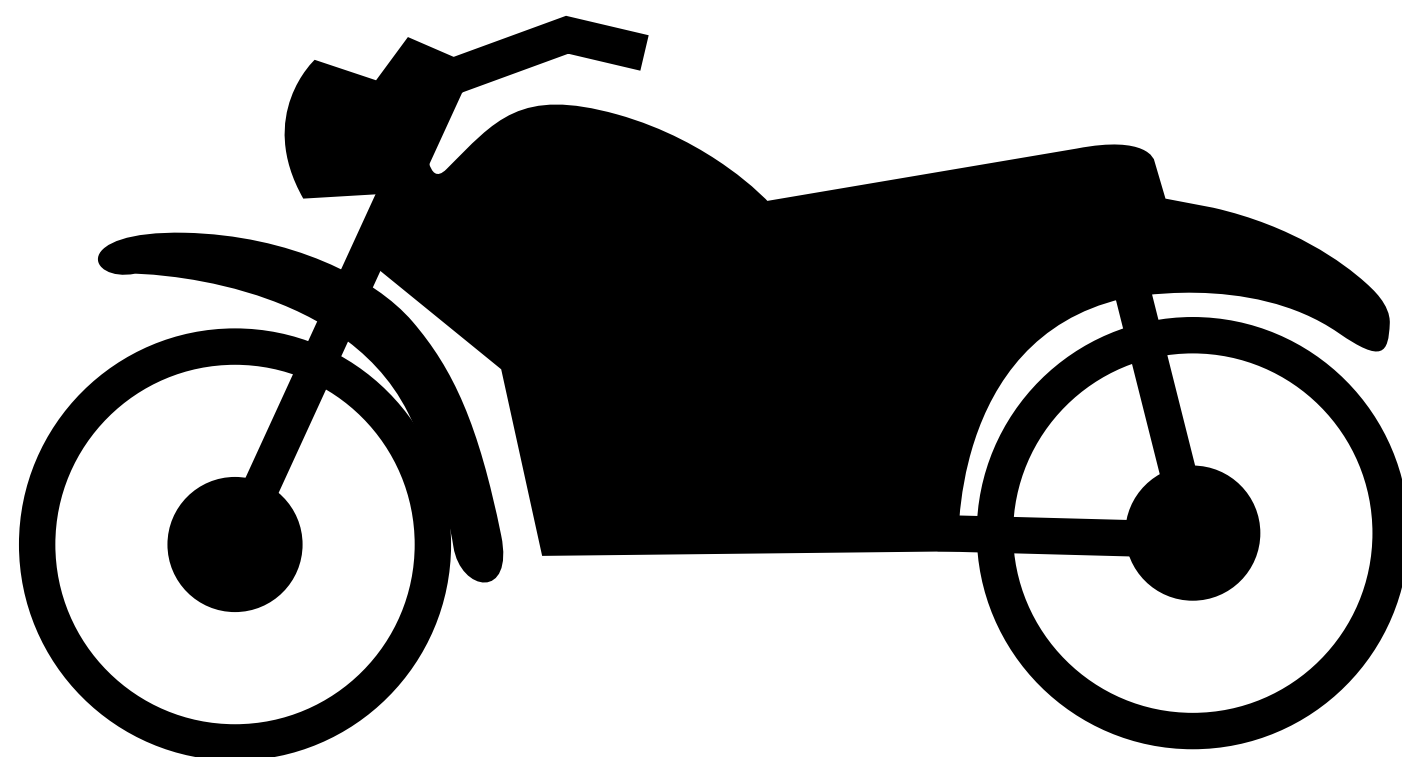

**GEN
INFO**

1

CHAPTER 1

GENERAL INFORMATION

MOTORCYCLE IDENTIFICATION	1-1
VEHICLE IDENTIFICATION NUMBER	1-1
MODEL CODE	1-1
FEATURES	1-2
OUTLINE	1-2
FI SYSTEM.....	1-3
COMPONENTS.....	1-5
FUEL INJECTION SYSTEM.....	1-17
THREE-WAY CATALYTIC CONVERTER SYSTEM.....	1-26
AIR INDUCTION SYSTEM.....	1-30
COMPONENTS.....	1-31
IMPORTANT INFORMATION	1-35
PREPARATION FOR REMOVAL AND DISASSEMBLY.....	1-35
REPLACEMENT PARTS.....	1-35
GASKETS, OIL SEALS AND O-RINGS	1-35
LOCK WASHERS/PLATES AND COTTER PINS	1-36
BEARINGS AND OIL SEALS	1-36
CIRCLIPS	1-36
CHECKING THE CONNECTIONS.....	1-37
SPECIAL TOOLS	1-38

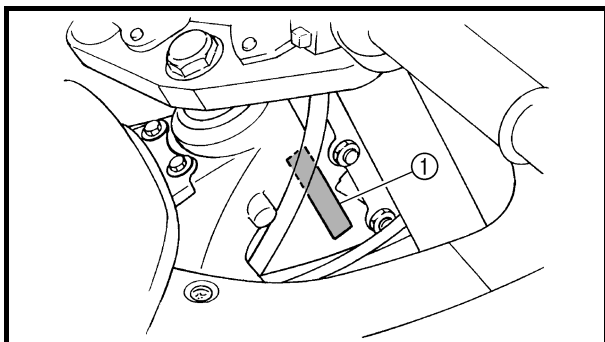

EAS00014

GENERAL INFORMATION MOTORCYCLE IDENTIFICATION

EAS00017

VEHICLE IDENTIFICATION NUMBER

The vehicle identification number ① is stamped into the right side of the steering head pipe.

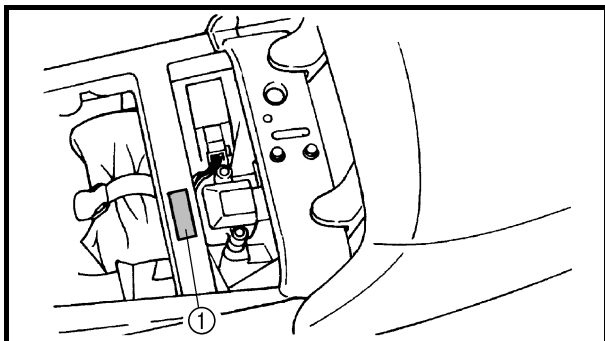

EAS00018

MODEL CODE

The model code label ① is affixed to the frame. This information will be needed to order spare parts.

FEATURES

OUTLINE

The main function of a fuel supply system is to provide fuel to the combustion chamber at the optimum air-fuel ratio in accordance with the engine operating conditions and the atmospheric temperature.

In the conventional carburetor system, the air-fuel ratio of the mixture that is supplied to the combustion chamber is created by the volume of the intake air and the fuel that is metered by the jet that is used in the respective chamber.

Despite the same volume of intake air, the fuel volume requirement varies by the engine operating conditions, such as acceleration, deceleration, or operating under a heavy load. Carburetors that meter the fuel through the use of jets have been provided with various auxiliary devices, so that an optimum air-fuel ratio can be achieved to accommodate the constant changes in the operating conditions of the engine.

As the requirements for the engine to deliver more performance and cleaner exhaust gases increase, it becomes necessary to control the air-fuel ratio in a more precise and finely tuned manner. To accommodate this need, this model has adopted an electronically controlled fuel injection (FI) system, in place of the conventional carburetor system. This system can achieve an optimum air-fuel ratio required by the engine at all times by using a microprocessor that regulates the fuel injection volume according to the engine operating conditions detected by various sensors.

The adoption of the FI system has resulted in a highly precise fuel supply, improved engine response, better fuel economy, and reduced exhaust emissions. Furthermore, the air induction system (AI system) has been placed under computer control together with the FI system in order to realize cleaner exhaust gases.

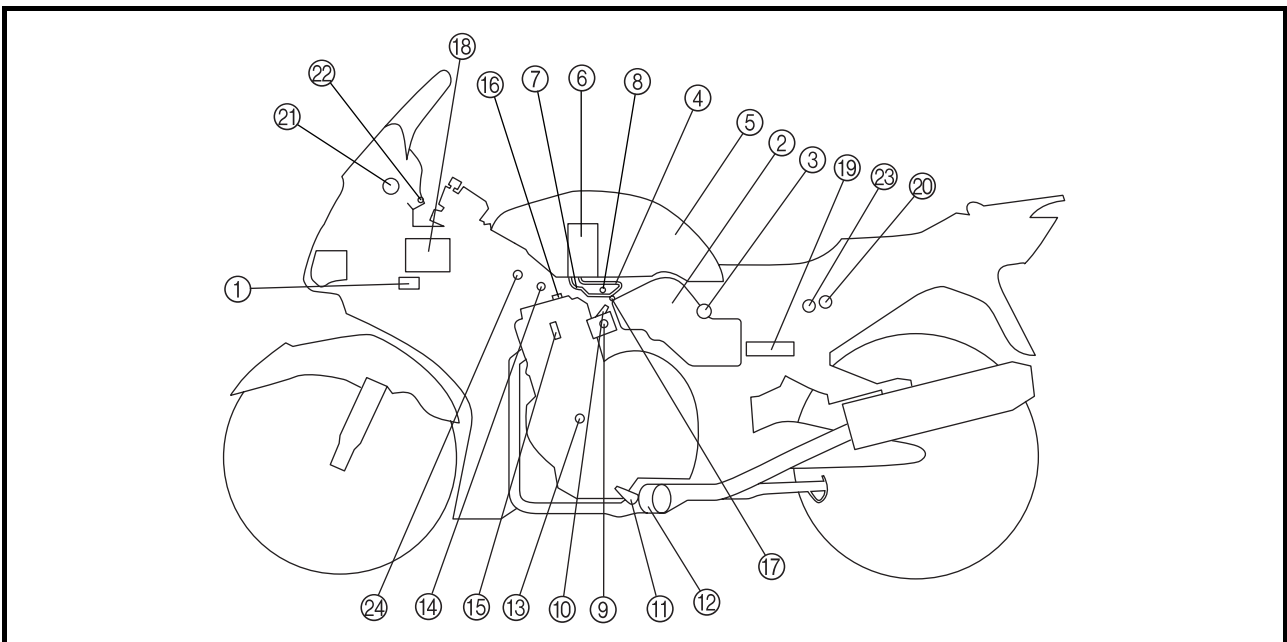

- | | | | |
|-----------------------------|------------------------------|----------------------------------|--------------------------------|
| ① Ignition coil | ⑧ Intake air pressure sensor | ⑮ Spark plug | ⑳ Engine trouble warning light |
| ② Air filter case | ⑨ Throttle position sensor | ⑯ Cylinder identification sensor | ㉑ Lean angle cut-off switch |
| ③ Intake temperature sensor | ⑩ Fuel injector | ⑰ Pressure regulator | ㉒ Air cut-off valve |
| ④ Fuel delivery hose | ⑪ O ₂ sensor | ⑱ Battery | |
| ⑤ Fuel tank | ⑫ Catalytic converter | ⑲ ECU | |
| ⑥ Fuel pump | ⑬ Crankshaft position sensor | ㉓ Atmospheric pressure sensor | |
| ⑦ Fuel return hose | ⑭ Coolant temperature sensor | ㉔ Fuel injection system relay | |

FI SYSTEM

The fuel pump delivers fuel to the injector via the fuel filter. The pressure regulator maintains the fuel pressure that is applied to the injector at only 2.55 kg/cm² higher than the intake manifold pressure. Accordingly, when the energizing signal from the ECU energizes the injector, the fuel passage opens, causing the fuel to be injected into the intake manifold only during the time the passage remains open. Therefore, the longer the length of time the injector is energized (injection duration), the greater the volume of fuel that is supplied. Conversely, the shorter the length of time the injector is energized (injection duration), the lesser the volume of fuel that is supplied.

The injection duration and the injection timing are controlled by the ECU. Signals that are input from the throttle position sensor, crankshaft position sensor, intake air pressure sensor, atmospheric pressure sensor, intake temperature sensor, coolant temperature sensor, and O₂ sensor enable the ECU to determine the injection duration. The injection timing is determined through the signals from the crankshaft position sensor and the cylinder identification sensor. As a result, the volume of fuel that is required by the engine can be supplied at all times in accordance with the driving conditions.

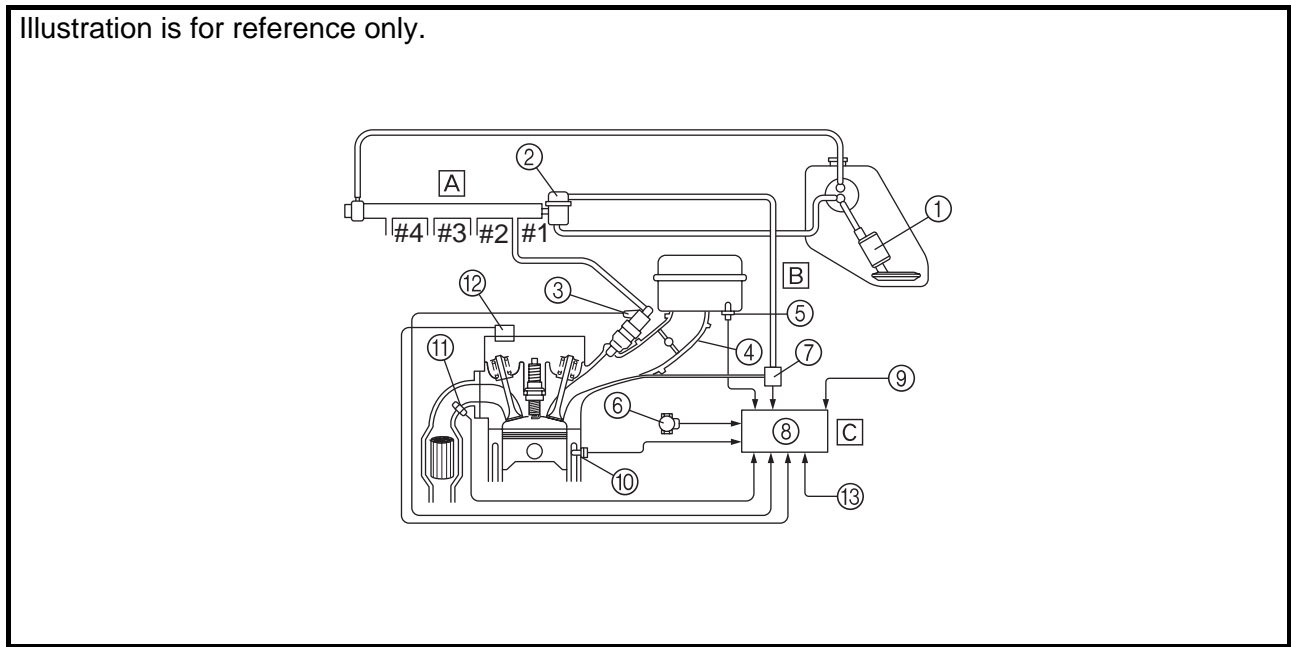

- | | | | |
|-----------------------------|-------------------------------|----------------------------------|------------------|
| ① Fuel pump | ⑥ Throttle position sensor | ⑩ Coolant temperature sensor | Ⓐ Fuel system |
| ② Pressure regulator | ⑦ Intake air pressure sensor | ⑪ O ₂ sensor | Ⓑ Air system |
| ③ Fuel injector | ⑧ ECU | ⑫ Cylinder identification sensor | Ⓒ Control system |
| ④ Throttle body | ⑨ Atmospheric pressure sensor | ⑬ Crankshaft position sensor | |
| ⑤ Intake temperature sensor | | | |

Fuel control block

The fuel control block consists of the following main components:

	Component	Function
Control block	ECU	Total FI system control
	Throttle body	Air volume control
	Pressure regulator	Fuel pressure detection
Sensor block	Intake air pressure sensor	Intake air pressure detection
	Atmospheric pressure sensor	Atmospheric pressure detection
	Coolant temperature sensor	Coolant temperature detection
	Intake temperature sensor	Intake temperature detection
	Throttle position sensor	Throttle angle detection
	O ₂ sensor	Gas emission O ₂ concentration detection
	Cylinder identification sensor	Reference position detection
	Crankshaft position sensor	Crankshaft position detection and engine RPM detection
Actuator block	Speed sensor	Speed detection
	Injector	Fuel injection
	Fuel pump	Fuel feed
	Air Induction system, air cut valve	Induction of secondary air

An FI warning light is provided on meter panel.

COMPONENTS

ECU (Electronic Control Unit)

The ECU is mounted underneath the seat, below the toolbox. The main functions of the ECU are ignition control, fuel control, self-diagnosis, and load control.

- ECU's internal construction and functions

The main components and functions of the ECU can be broadly divided into the following four items:

A. Power supply circuit

The power supply circuit obtains power from the battery (12 V) to supply the power (5 V) that is required for operating the ECU.

B. Input interface circuits

The input interface circuits convert the signals output by all the sensors into digital signals, which can be processed by the CPU, and input them into the CPU.

C. CPU (Central Processing Unit)

The CPU determines the condition of the sensors in accordance with the level of the signal that is output by the respective sensor. Then, the signals are temporarily stored on the RAM in the CPU. Based on those stored signals and the basic processing program on the ROM, the CPU calculates the fuel injection duration, injection timing, and ignition timing, and then sends control commands to the respective output interface circuits.

D. Output interface circuits

The output interface circuits convert the control signals output by the CPU into actuating signals for the respective actuators in order to actuate them. They also output commands to the indicator and relay output circuits as needed.

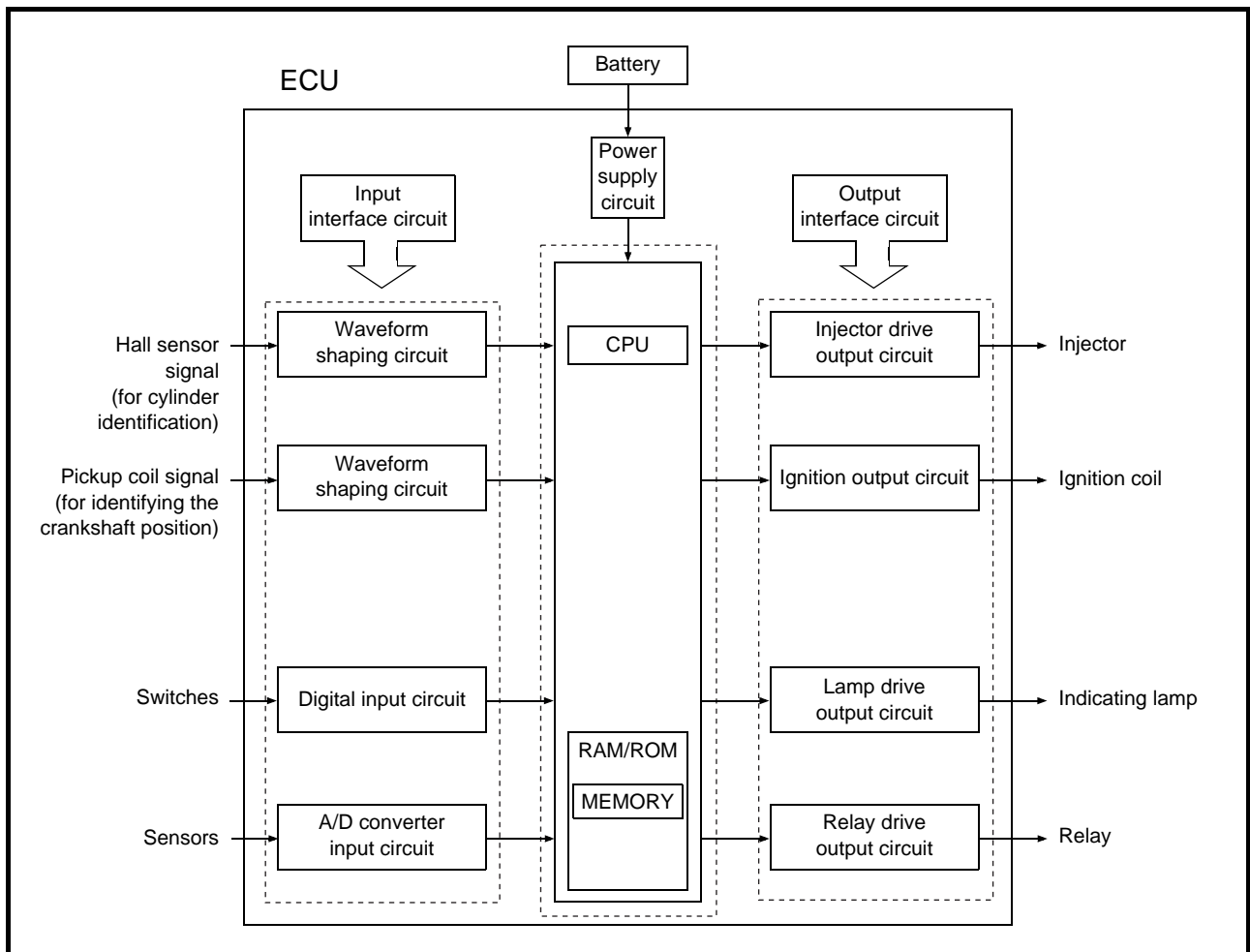

- Ignition control

The ignition control function of the ECU controls the ignition timing and the duration of ignition energizing. The ignition timing control uses the signals from the throttle position sensor (to detect the angle of the throttle), and the crankshaft position sensor and speed sensor (to detect the speed of the engine). This control establishes an ignition timing that suits the operating condition of the engine through compensations made to the basic ignition timing control map. The ignition energizing duration control establishes the energizing duration to suit the operating conditions by calculating the energizing duration in accordance with the signal received from the crankshaft position sensor and the battery voltage.

- Fuel control

The fuel control function of the ECU controls the injection timing and injection duration. The injection timing control controls the injection timing during the starting of the engine and the injection timing during the normal operation of the engine, based on the signals received from the crankshaft position sensor and the cylinder identification sensor. The injection duration control determines the duration of injection based on the signals received from the atmospheric pressure sensors, temperature sensors, and the position sensors, to which compensations are made to suit various conditions such as the weather, atmospheric pressure, starting, acceleration, and deceleration.

- Load control

The ECU effects load control in the following manner:

1. Stopping the fuel pump and injectors when the motorcycle overturns

The ECU turns OFF the fuel injection system relay when the lean angle cut-off switch is tripped.

2. Operating the headlight illumination relay

On the model for Europe, the ECU causes the headlight relay 2 to output a constant ON signal, provided that the main switch is ON. On the model for Australia, the ECU controls the headlight relay 2 in accordance with the engine speed as required by the daytime illumination specification.

3. Operating the radiator fan motor in accordance with the coolant temperature

The ECU controls the radiator fan motor relay ON/OFF in accordance with the coolant temperature.

4. Operating the AI system solenoid valve

The ECU controls the energizing of the solenoid valve in accordance with the driving conditions.

- Self-diagnosis function

The ECU is equipped with a self-diagnosis function to ensure that the engine control system is operating normally. The ECU mode functions include a diagnosis mode in addition to the normal mode.

Normal mode

- To check for any blown bulbs, this mode illuminates a warning light while the main switch is turned ON, and while the starter switch is being pressed.
- If the starting disable warning is activated, this mode alerts the rider by blinking the warning light while the start switch is being pressed.
- If a malfunction occurs in the system, this mode provides an appropriate substitute characteristic operation, and alerts the rider of the malfunction by illuminating a warning light. After the engine is stopped, this mode displays a fault code on the clock LCD.

Diagnosis mode

- In this mode, a diagnostic code is input into the ECU through the operation of the operating switch on the meter, and the ECU displays the values output by the sensors or actuates the actuators in accordance with the diagnostic code. Whether the system is operating normally can be checked by observing the illumination of the warning light, the values displayed on the meter, or the actuating state of the actuators.

Fuel pump

The fuel pump, which is mounted in the fuel tank, draws the fuel directly from the tank and pumps it to the injector.

A filter that is provided in the fuel pump prevents any debris in the fuel tank from entering the fuel system downstream of the pump.

The pump consists of a pump unit, electric motor, filter, and valves.

The pump unit is a Wesco type rotary pump that is connected to the motor shaft.

A relief valve is provided to prevent the fuel pressure from rising abnormally if the fuel hose becomes clogged. This valve opens when the fuel pressure at the discharge outlet reaches between 440 and 640 kpa, and returns the fuel to the fuel tank.

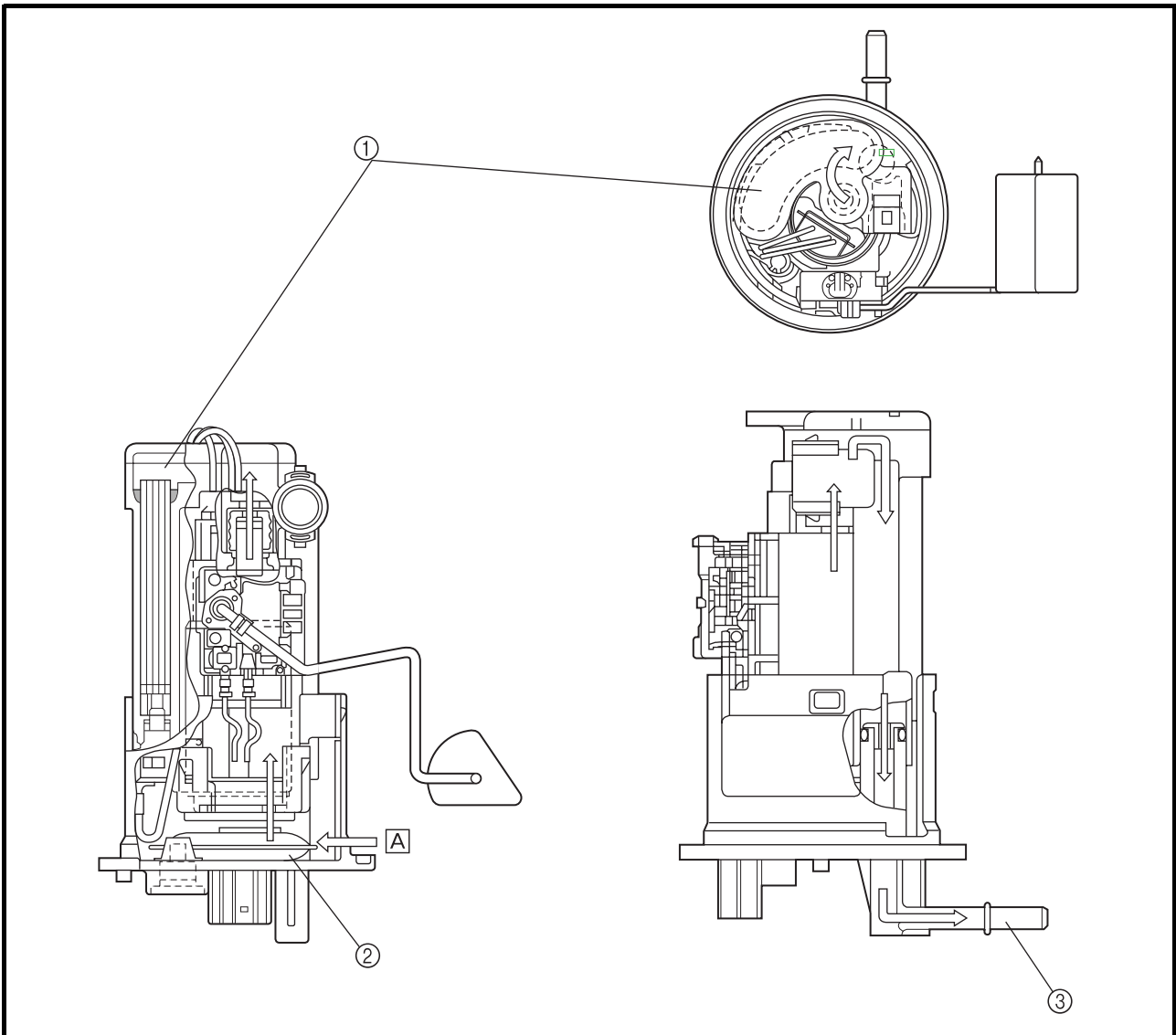

- ① Fuel filter
- ② Fuel inlet strainer
- ③ Outlet
- A Fuel

Pressure regulator

It regulates the fuel pressure that is applied to the injectors that are provided in the cylinders in order to maintain a constant pressure difference with the pressure in the intake manifold.

The fuel that is delivered by the fuel pump fills the fuel chamber through the fuel inlet of the regulator and exerts pressure on the diaphragm in the direction for opening the valve.

A spring that is provided in the spring chamber exerts pressure on the diaphragm in the direction for closing the valve, in contrast to the pressure of the fuel. Thus, the valve cannot open unless the fuel pressure overcomes the spring force.

An intake vacuum is applied to the spring chamber via a pipe. When the pressure of the fuel exceeds the sum of the intake vacuum and the spring force, the valve that is integrated with the diaphragm opens, allowing the fuel to return from the fuel outlet to the fuel tank, via the fuel return hose.

As a result, because the intake vacuum fluctuates in accordance with the changes in the operating conditions in contrast to the constant volume of fuel supplied by the pump, the valve opening/closing pressure also changes to regulate the return fuel volume. Thus, the difference between the fuel pressure and the intake manifold pressure remains constant at a prescribed pressure.

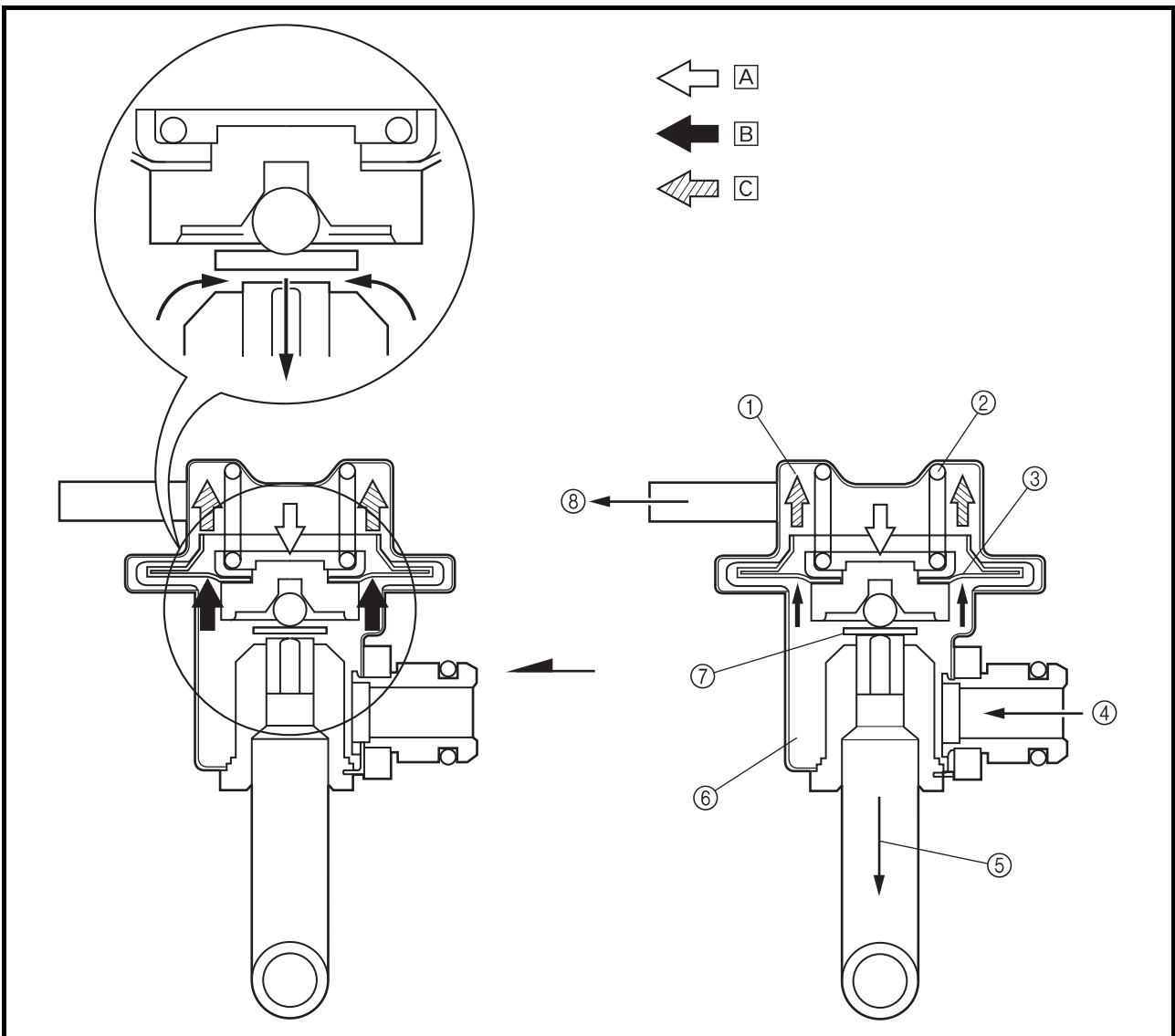

- ① Spring chamber
- ② Spring
- ③ Diaphragm

- ④ Fuel inlet
- ⑤ Fuel outlet
- ⑥ Fuel chamber

- ⑦ Valve
- ⑧ Intake manifold vacuum pressure

- Ⓐ Spring pressure
- Ⓑ Fuel pressure
- Ⓒ Vacuum pressure

Fuel injector

Upon receiving injection signals from the ECU, the fuel injector injects fuel. In the normal state, the core is pressed downward by the force of the spring, as illustrated. The needle that is integrated with the bottom of the core keeps the fuel passage closed.

When the current flows to the coil in accordance with the signal from the ECU, the core is drawn upward, allowing the flange that is integrated with the needle to move to the spacer. Since the distance of the movement of the needle is thus kept constant, the opening area of the fuel passage also becomes constant. Because the pressure difference of the fuel to the intake manifold pressure is kept constant by the pressure regulator, the fuel volume varies in proportion to the length of time the coil is energized. The injector that has been recently adopted has a four-hole type injection orifice that enhances the atomization of fuel and improves combustion efficiency.

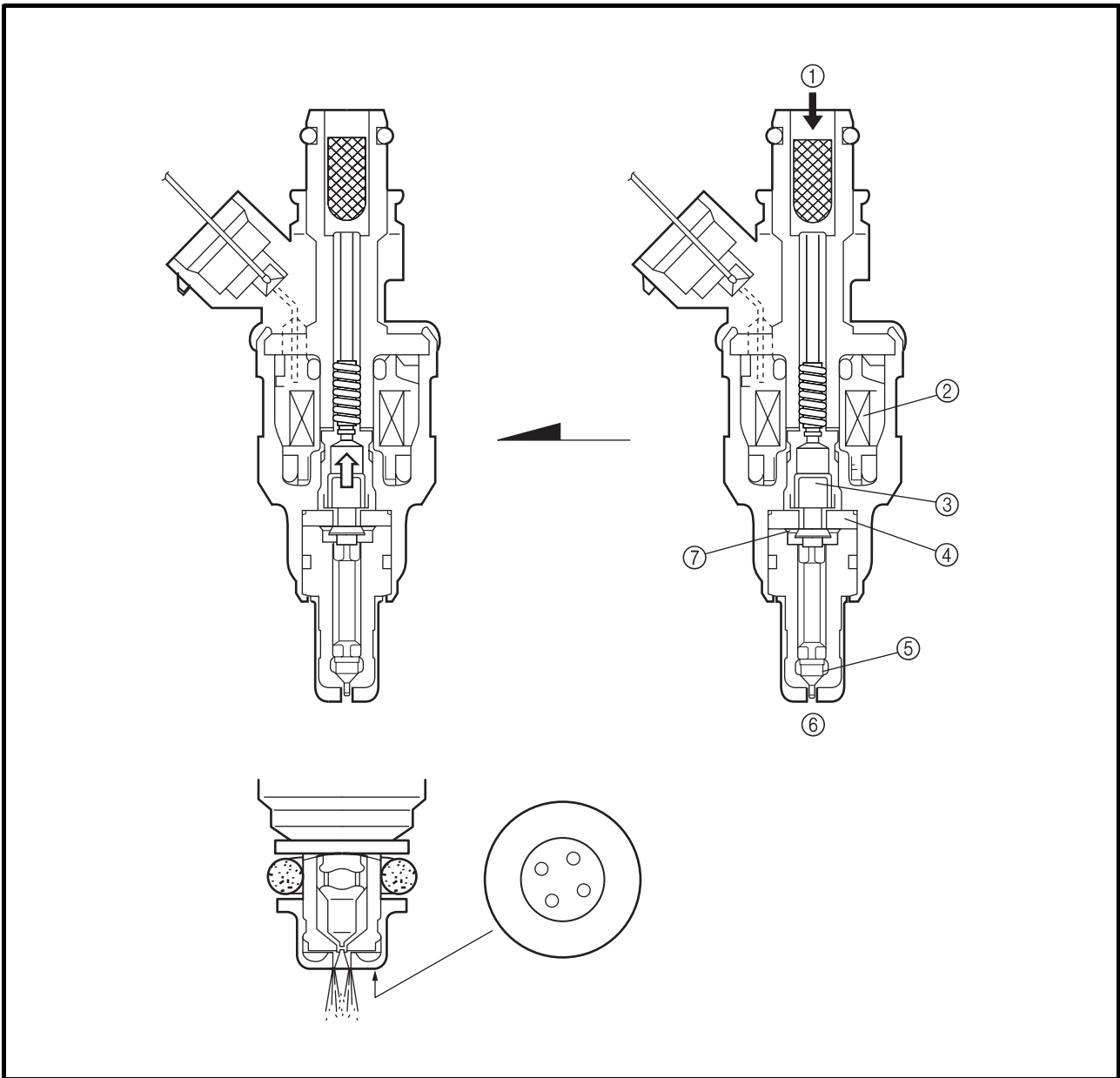

- ① Fuel
- ② Coil
- ③ Core
- ④ Spacer
- ⑤ Needle
- ⑥ Inject
- ⑦ Flange

Crankshaft position sensor

The crankshaft position sensor uses the signals of the pickup coil that is mounted on the right side of the crankshaft. When the rotation of the pickup rotor that is attached to the crankshaft causes the projections on the rotor to pass by the pickup coil, an electromotive force is generated in the coil. The voltage of this force is then input into the ECU, which calculates the position of the crankshaft and the speed of the engine. The ignition timing is then determined in accordance with the calculated data, in order to determine the corresponding injection timing. Based on the changes in the time intervals of the signals generated by the pickup coil, the ECU calculates the ignition timing advance to suit the operating conditions. The injection timing is also advanced in accordance with the ignition timing in order to supply fuel to the engine at an optimal timing.

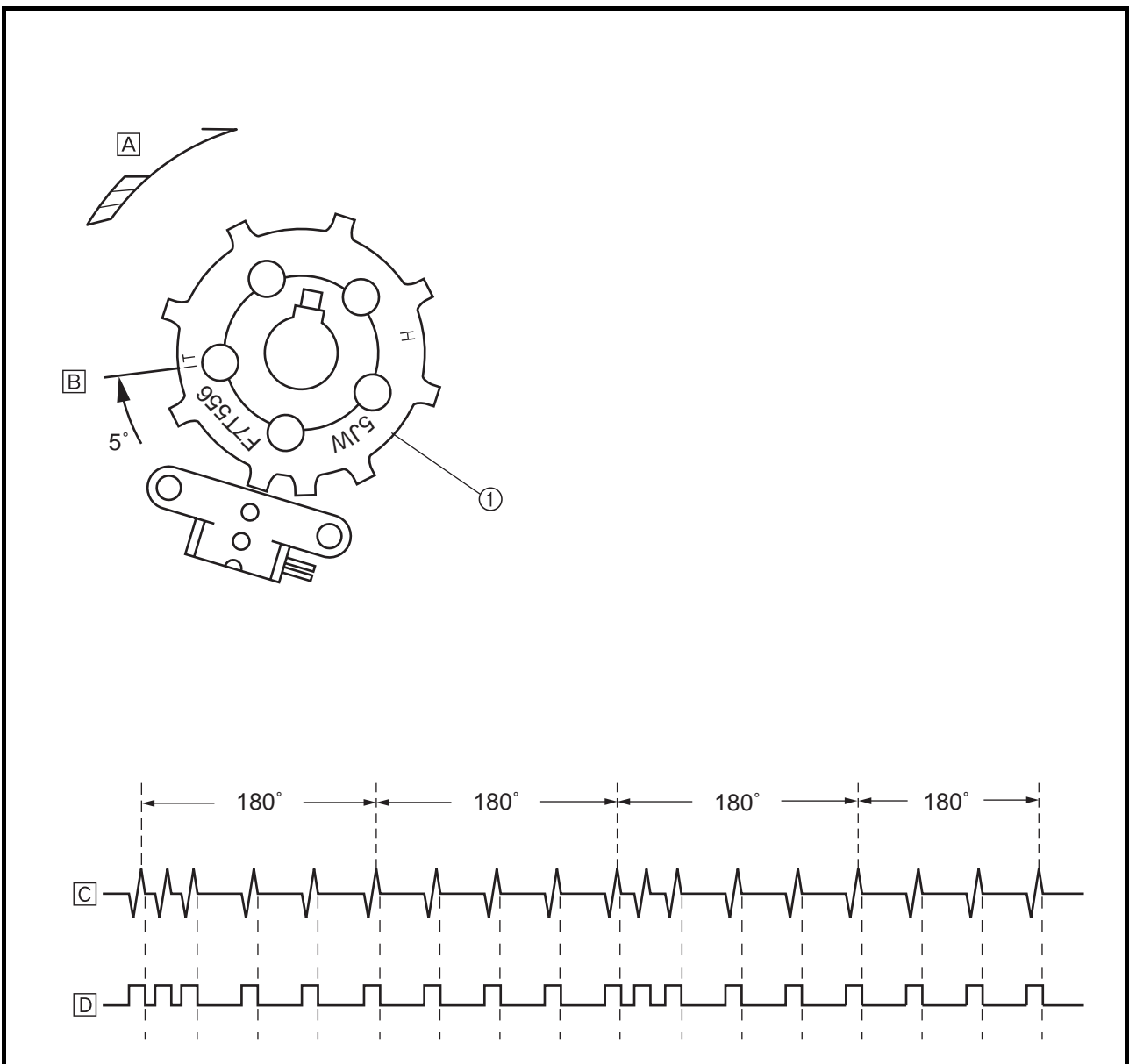

- ① Pickup rotor
- A Direction of rotation
- B #1 cylinder compression stroke, 5° BTDC
- C Pickup signal
- D Trigger pole

Cylinder identification sensor

The cylinder identification sensor is mounted on the exhaust head cover of the #4 cylinder. When the exhaust cam of the #4 cylinder rotates and the lift of the cam passes by the sensor, the sensor generates a signal and sends it to the ECU. Based on this signal and the signal from the crankshaft position sensor, the ECU then actuates the injector of the cylinder that is currently in order to supply fuel.

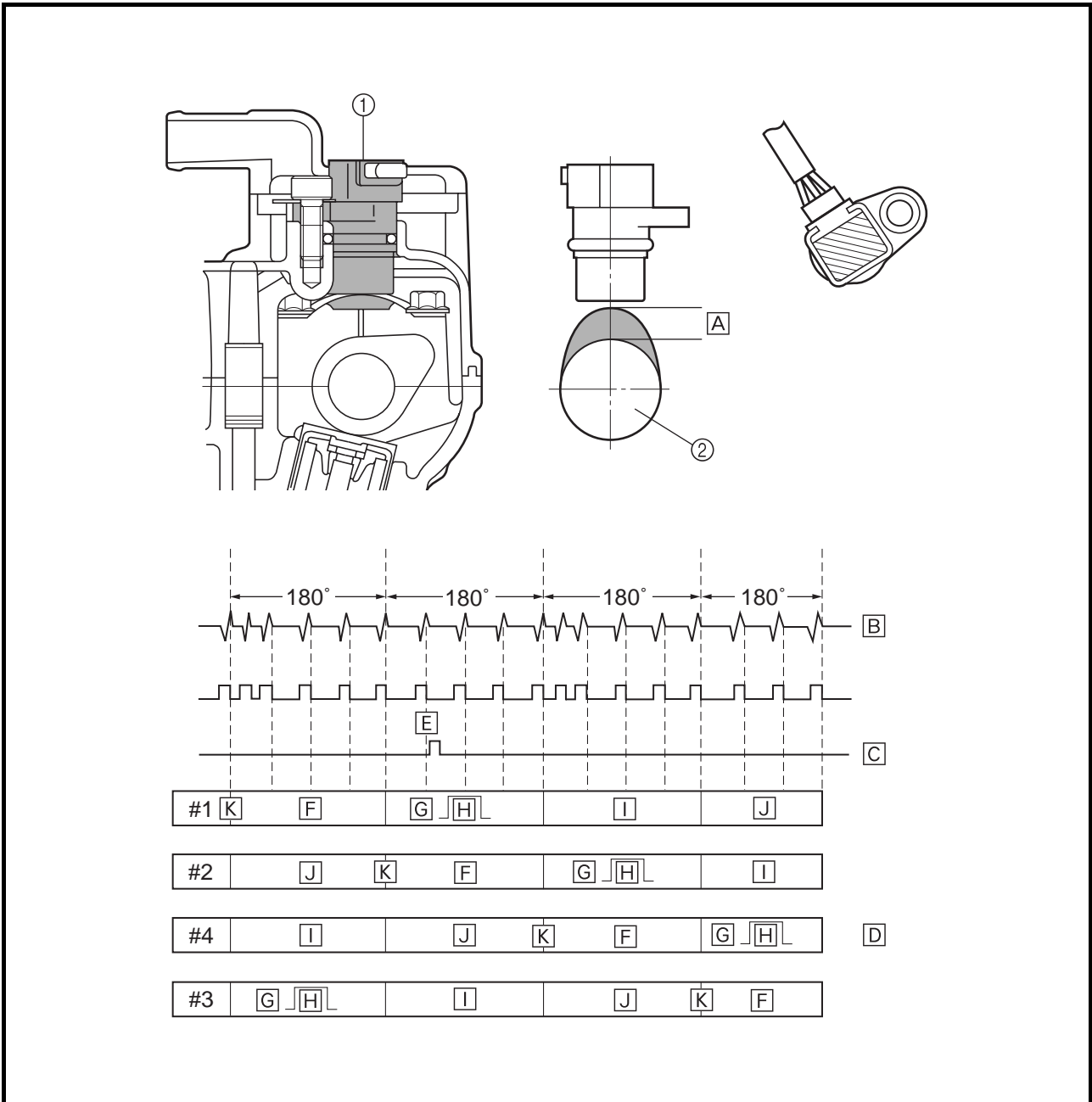

- ① Cylinder identification sensor
- ② Cam

- A Cam lift
- B Crankshaft position sensor signal
- C Cylinder identification sensor signal

- D Cylinder firing order
- E #4 cam lobe onto exhaust camshaft
- F Combustion

- G Exhaust
- H Injection
- I Intake
- J Compression
- K Ignition

Throttle position sensor

The throttle position sensor measures the intake air volume by detecting the position of the throttle valve. It detects the mechanical angle of the throttle valve through the positional relationship between the moving contact that moves in unison with the throttle shaft and the resistor board. In actual operation, the ECU supplies 5 V power to both ends of the resistor board and the voltage that is output by the throttle position sensor is used to determine the angle of the throttle valve.

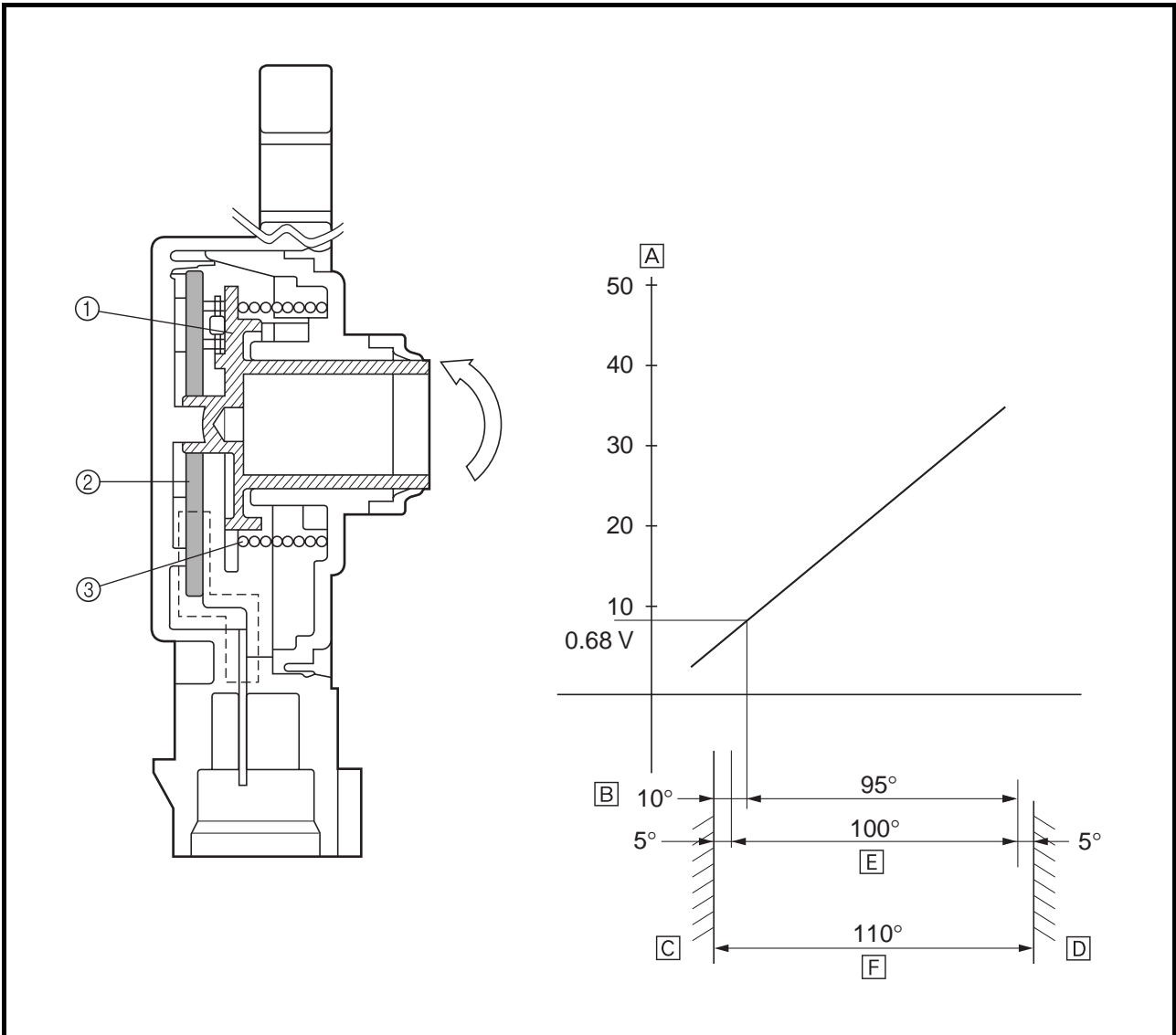

- ① Moving contact
- ② Resistor board
- ③ Spring
- [A] Output voltage
- [B] Idling output position
- [C] Mechanical stopper
- [D] Mechanical stopper
- [E] Effective electrical angle
- [F] Sensor operating angle

Intake air pressure sensor and atmospheric pressure sensor

• Intake air pressure sensor

The intake air pressure sensor is used for measuring the intake air volume. The intake air volume of every intake stroke is proportionate to the intake air pressure. Therefore, the intake air volume can be measured by measuring the intake air pressure. The intake air pressure sensor converts the measured intake air pressure into electrical signals and sends those signals to the ECU. When the intake air pressure is introduced into the sensor unit, which contains a vacuum chamber on one side of the silicon diaphragm, the silicon chip that is mounted on the silicon diaphragm converts the intake air pressure into electrical signals. Then, an integrated circuit (IC) amplifies and adjusts the signals and makes temperature compensations, in order to generate electrical signals that are proportionate to the pressure.

• Atmospheric pressure sensor

The atmospheric pressure sensor is used for making compensations to the changes in the air density caused by the changes in the atmospheric pressure (particularly at high altitudes). The operating principle and function of the atmospheric pressure sensor are the same as those of the aforementioned intake air pressure sensor.

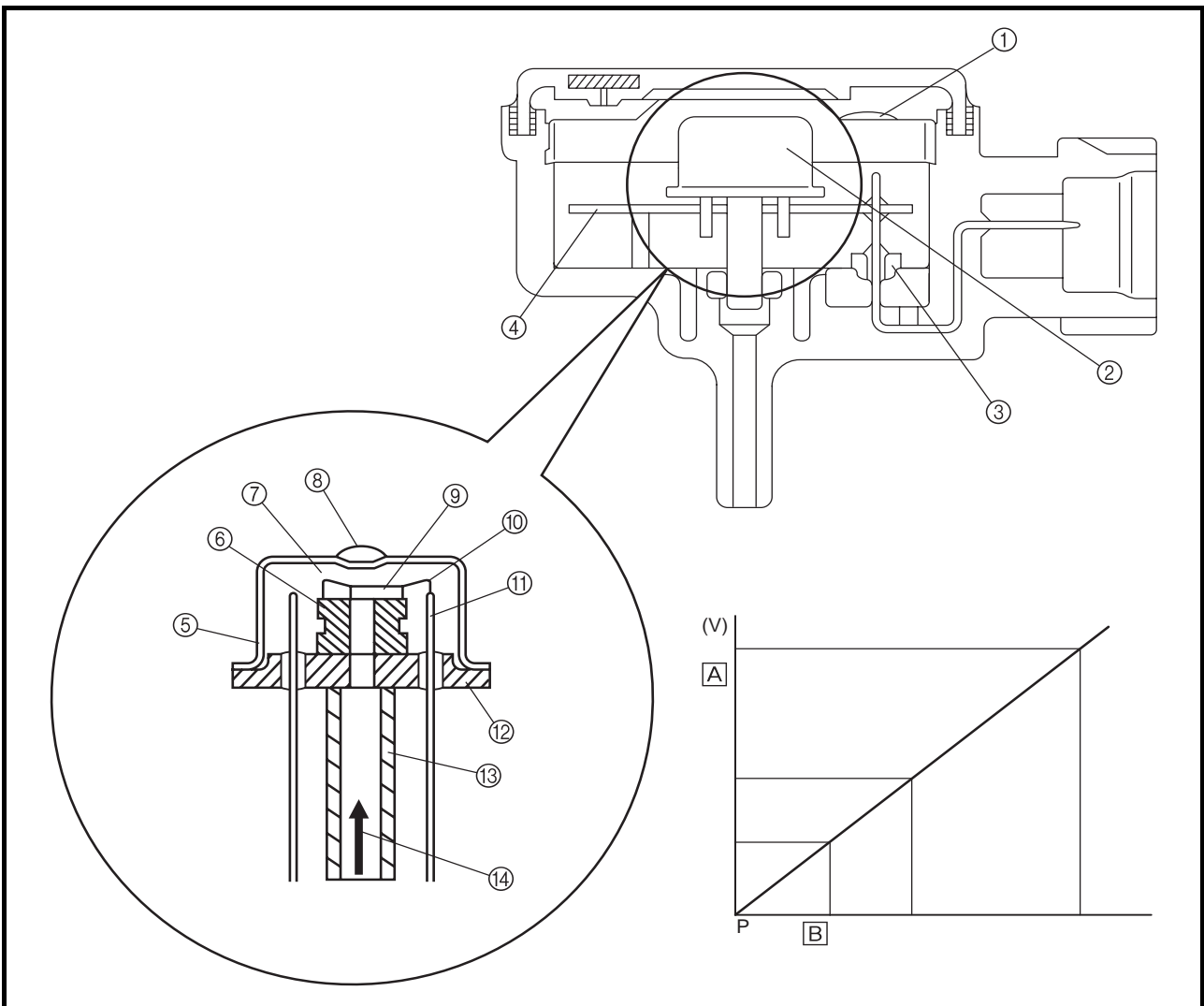

- | | | | |
|---------------------|---------------------|---|------------------|
| ① EMI shield | ⑥ Silicon diaphragm | ⑪ Lead pin | Ⓐ Output voltage |
| ② Sensor unit | ⑦ Vacuum chamber | ⑫ Stem | Ⓑ Input pressure |
| ③ Through condenser | ⑧ Solder | ⑬ Pressure induction pipe | |
| ④ Hybrid IC | ⑨ Silicon chip | ⑭ Atmospheric pressure, intake air pressure | |
| ⑤ Cap | ⑩ Gold wire | | |

Coolant temperature sensor

The signals from the coolant temperature sensor are used primarily for making fuel volume compensations during starting and warm-up. The coolant temperature sensor converts the temperature of the coolant into electrical signals and sends them to the ECU.

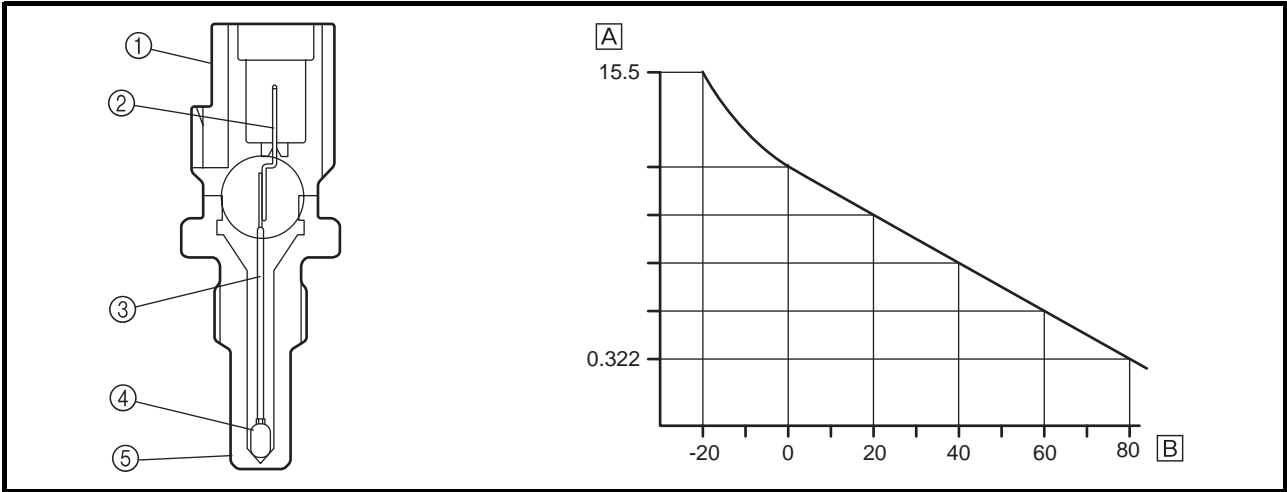

- ① Connector
- ② Terminal
- ③ Tube
- ④ Thermistor
- ⑤ Holder
- Ⓐ Resistance kΩ
- Ⓑ Temperature °C

Intake temperature sensor

The intake temperature sensor corrects the deviation of the air-fuel mixture that is associated with the changes in the intake air density, which are created by the changes in the intake air temperature that occur due to atmospheric temperatures. This sensor uses a semi-conductor thermistor that has a large resistance at low temperatures and a small resistance at high temperatures. The thermistor converts the temperature-dependent changes in resistance into electrical resistance values, which are then input into the ECU.

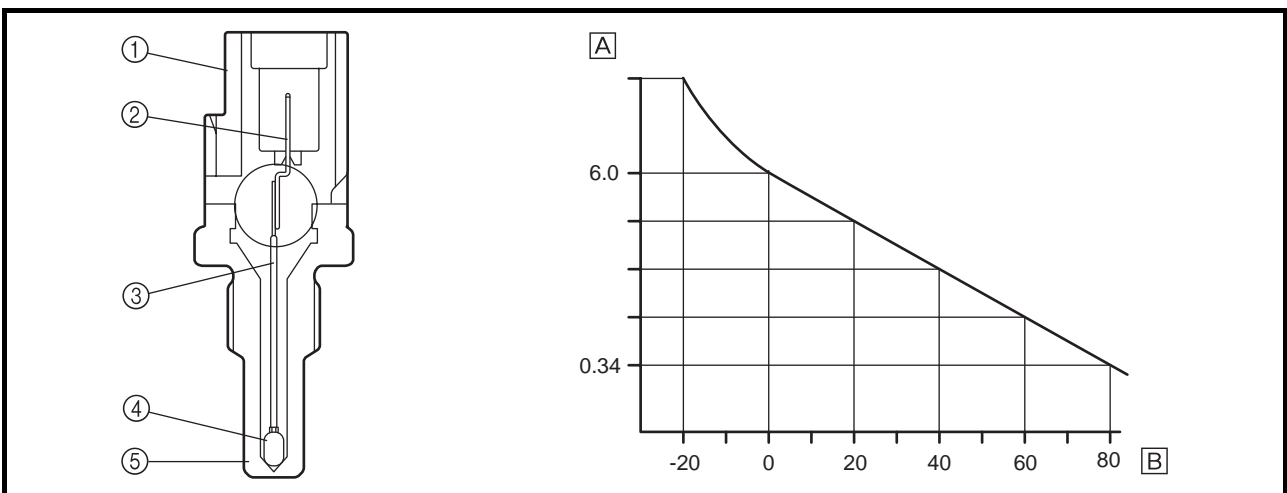

- ① Connector
- ② Terminal
- ③ Tube
- ④ Thermistor
- ⑤ Holder
- Ⓐ Resistance kΩ
- Ⓑ Temperature °C

O₂ sensor

The O₂ sensor has been adopted to enable the catalyst to function at a high degree of efficiency by maintaining the air-fuel mixture near the stoichiometric ratio (14.7:1). This sensor, which is a zirconia type, utilizes the oxygen ion conductivity of the solid electrolyte for detecting the oxygen concentration levels. In actual operation, a zirconia tube made of solid electrolyte is exposed in the exhaust gas, so that the exterior of the zirconia tube is in contact with the exhaust gas and the interior is in contact with the atmosphere whose oxygen concentration level is known. When a difference in the oxygen concentration level is created between the outside and the inside of the zirconia tube, the oxygen ion passes through the zirconia element and generates an electromotive force. The electromotive force increases when the oxygen concentration level is low (rich air-fuel ratio) and the electromotive force decreases when the oxygen concentration level is high (lean air-fuel ratio). As electromotive force is generated in accordance with the concentration of the exhaust gas, the resultant voltage is input into the ECU in order to correct the duration of the injection of fuel.

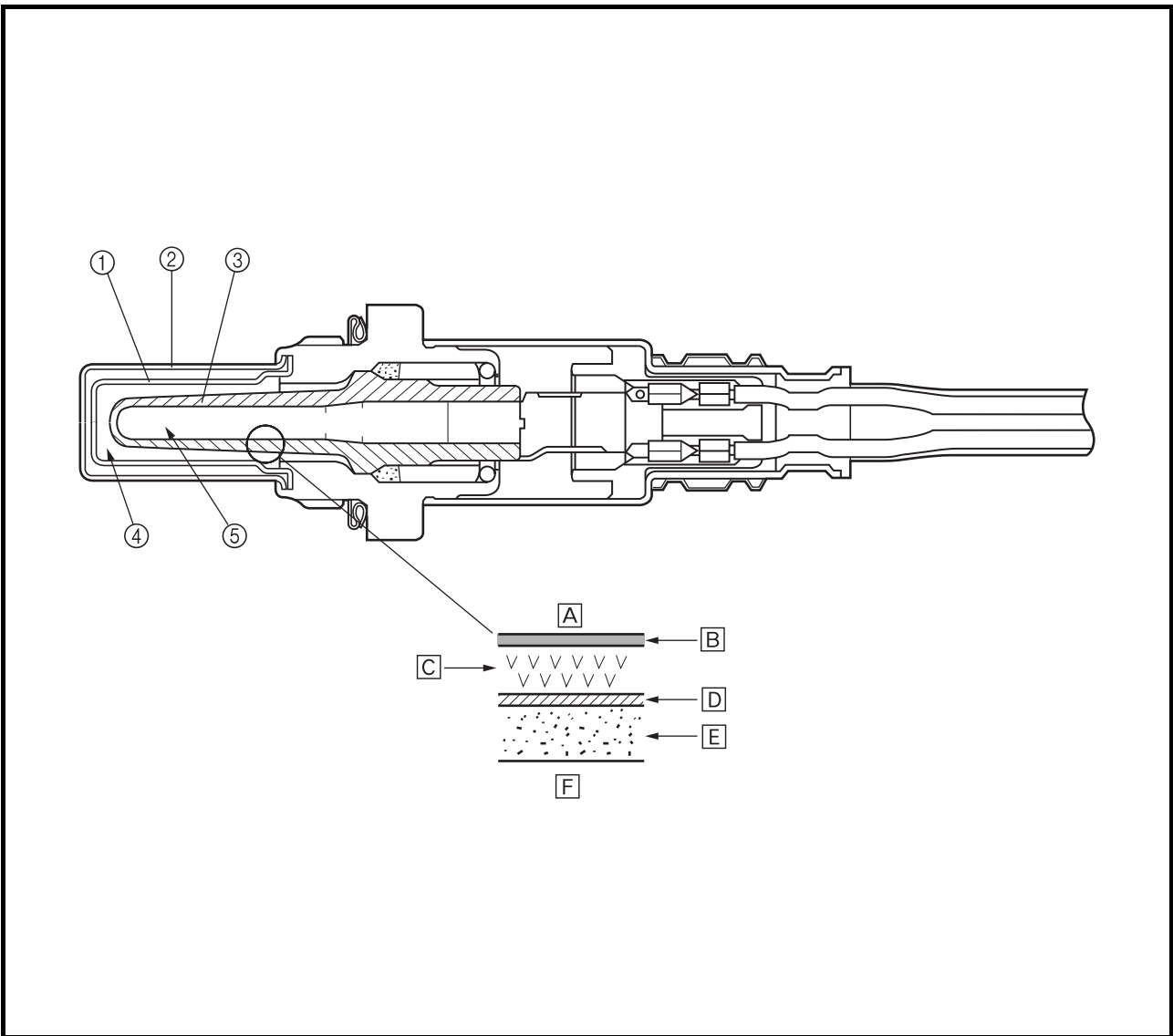

- ① Inner cover
- ② Outer cover
- ③ Zirconia tube

- ④ Exhaust gas
- ⑤ Atmosphere

- A Atmosphere
- B Inner electrode
- C Zirconia element

- D Outer electrode
- E Porous ceramic layer
- F Exhaust gas

Lean angle cut-off switch

The lean angle cut-off switch stops the supply of fuel to the engine in case the motorcycle overturns. When the motorcycle is in the normal state, the cut-off switch outputs a constant voltage of approximately 1.0 V (low level). When the motorcycle tilts, the float in the switch tilts in proportion to the tilt of the motorcycle. However, the voltage output to the ECU remains unchanged at the low level. When the tilt of the motorcycle exceeds 70 degrees (according to the tilt of the float), the signal from the sensor increases to approximately 4.0 V (high level). When the ECU receives the high-level voltage, it determines that the motorcycle has overturned, and stops the delivery of fuel to the engine by turning OFF the fuel injection system relay that powers the fuel pump and the injectors. Once the cut-off switch is tripped, the ECU maintains this state; therefore, even if the motorcycle has recovered its upright position, this state will not be canceled unless the main switch is turned OFF, and then turned back ON.

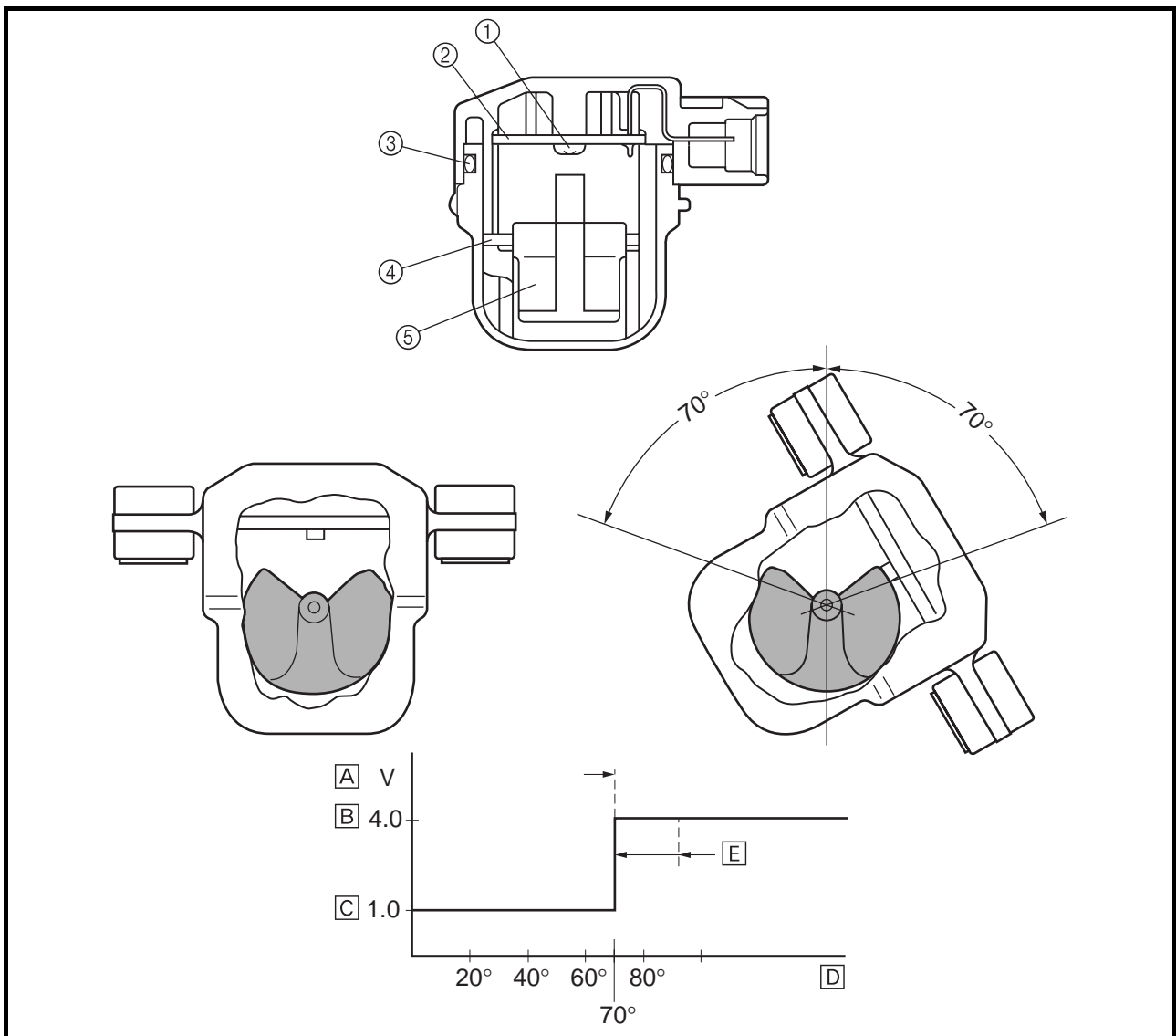

- ① Thyristor
- ② IC unit
- ③ O-ring
- ④ Shaft
- ⑤ Float
- Ⓐ Output voltage
- Ⓑ High level
- Ⓒ Low level
- Ⓓ Cut-off switch tilt angle
- Ⓔ Fuel injection system relay OFF

FUEL INJECTION SYSTEM

Operation and control

The fuel injection timing, injection duration, ignition timing, and the coil energizing duration are controlled by the ECU. To determine the basic injection timing, the ECU calculates the intake air volume through the signals from the intake air pressure sensor, throttle position sensor, cylinder identification sensor, and crankshaft position sensor.

Furthermore, the ECU calculates the final injection timing by adding the following compensations to the aforementioned basic injection duration: those obtained from the state of acceleration, as well as those based on the signals from various sensors such as the coolant temperature, intake temperature, atmospheric, and exhaust pipe oxygen concentration level. At the same time, the ECU assesses the crankshaft position through the signals from the cylinder identification sensor and the crankshaft position sensor. Then, when the ECU determines that it is time to inject fuel, it sends an injection command to the injectors. Furthermore, the ECU also controls the length of time the coil is energized by calculating the ignition timing and the coil energizing duration based on the signals from these sensors.

Determining the basic injection duration

The intake air volume determines the basic injection duration. In order to operate the engine in an optimal condition, it is necessary to supply fuel at an air-fuel ratio that corresponds appropriately to the volume of intake air that is constantly changing, and to ignite it an appropriate timing. The ECU controls the basic injection duration based on the intake air volume and engine speed data.

Detection of intake air volume

The intake air volume is detected primarily through the signals from the throttle position sensor and the intake air pressure sensor. The intake air volume is determined in accordance with the signals from the atmospheric pressure sensor, intake temperature sensor, and the engine speed data.

Composition of basic injection duration

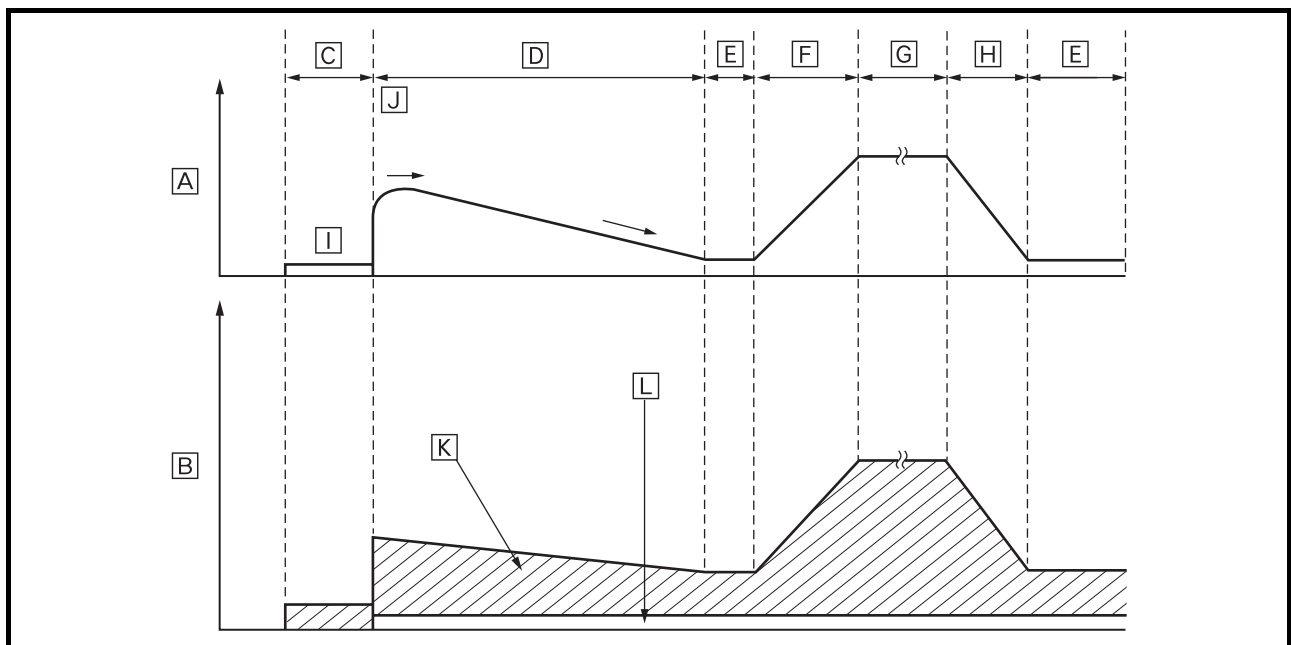

- | | | | |
|------------------------|------------------|------------------|-----------------------------------|
| [A] RPM | [D] Warm-up | [G] Constant | [J] After start |
| [B] Injection duration | [E] Idle | [H] Deceleration | [K] Basic injection duration |
| [C] Cranking | [F] Acceleration | [I] Start | [L] Voltage compensation duration |

Determining the final injection duration

The intake air volume determines the basic injection duration. However, at a given intake air volume, the volume of fuel that is required varies by the engine operating conditions such as acceleration or deceleration, or by weather conditions. This system uses various sensors to precisely check these conditions, applies compensations to the basic injection duration, and determines the final injection duration based on the operating condition of the engine.

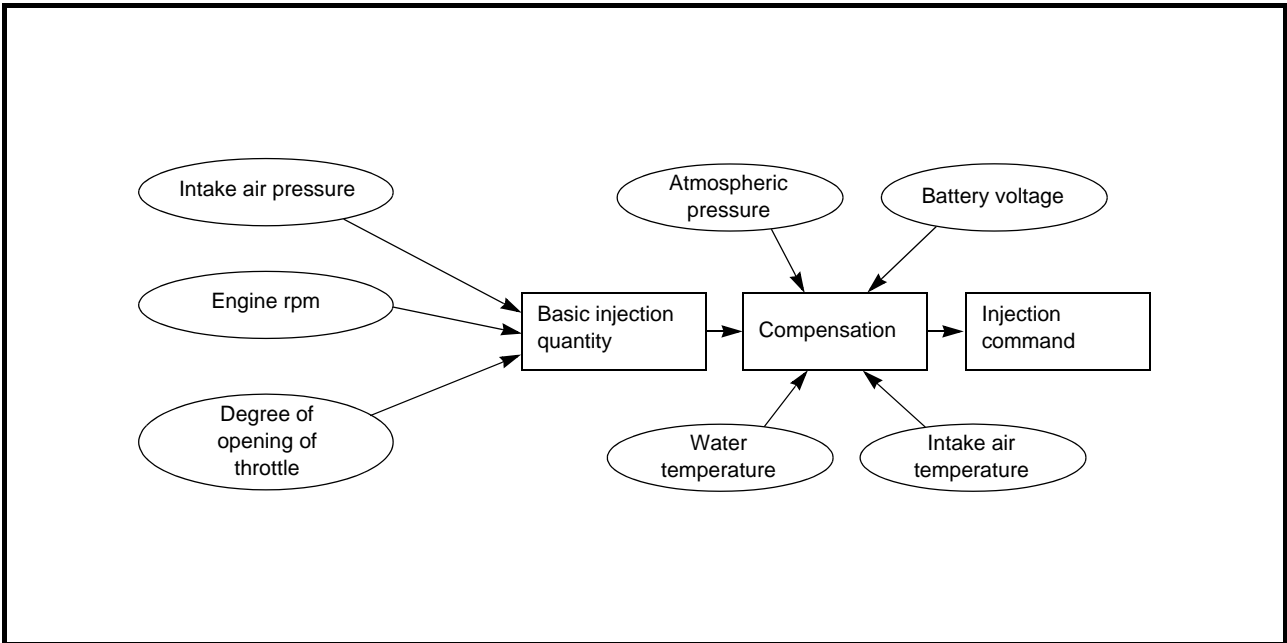

The fuel is cut off under conditions that do not require fuel, in order to stop the injection.

Composition of final injection duration

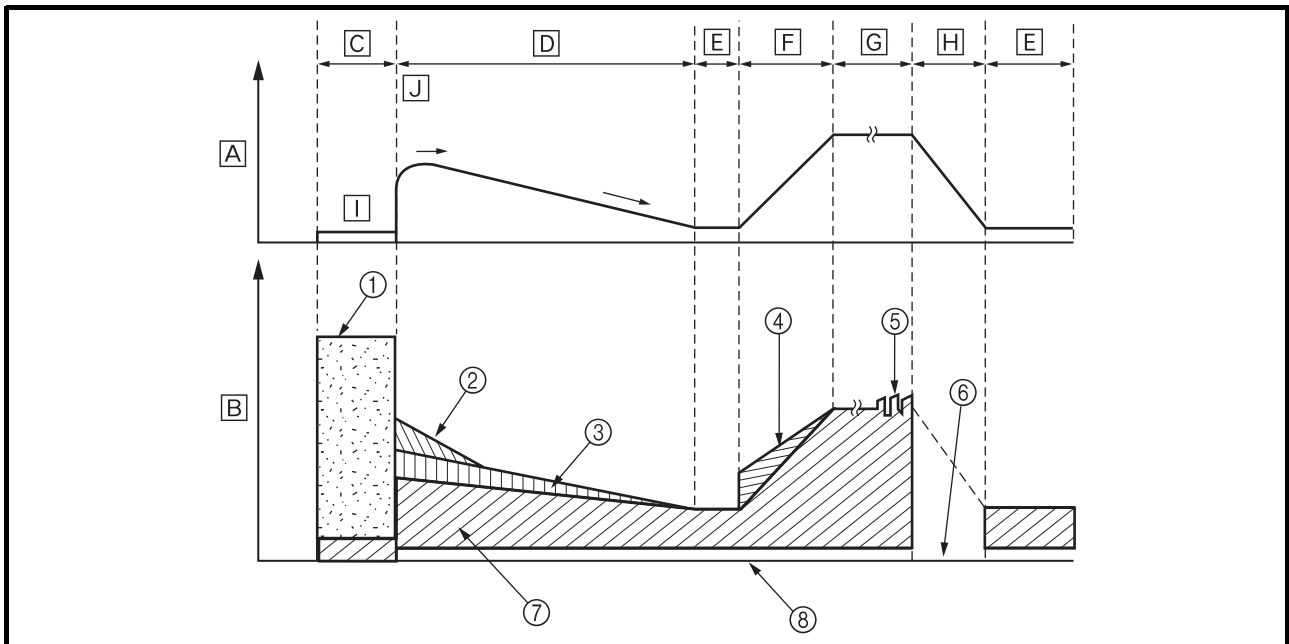

- ① Injection at start *1
- ② After-start enrichment *2
- ③ Warm-up enrichment *3
- ④ Acceleration compensation *5
- ⑤ Oxygen feedback *6
- ⑥ Fuel cut-off
- ⑦ Basic injection duration
- ⑧ Voltage compensation duration
- A RPM
- B Injection duration
- C Cranking
- D Warm-up
- E Idle
- F Acceleration
- G Constant
- H Deceleration
- I Start
- J After start

Reactive injection duration:

A lag is created between the time the ECU outputs a fuel injection signal to the injector and the time the injector actually opens. Therefore, the ECU calculates this lag in advance before sending the actuation signal to the injector. The battery voltage determines the reactive injection duration.

- High voltage → short reactive injection duration
- Low voltage → long reactive injection duration

LIST OF FUEL INJECTION COMPENSATIONS

Compensation item	Check item	Sensor used
Starting injection *1	Coolant temperature	Coolant temperature sensor
After-start injection:		
After-start enrichment *2	Coolant temperature	Coolant temperature sensor
Warm-up enrichment *3	Coolant temperature	Coolant temperature sensor
Intake temperature compensation *4	Intake temperature	Intake temperature sensor
Acceleration compensation/deceleration compensation *5	Intake air pressure	Intake air pressure sensor
	Throttle position	Throttle position sensor
	Coolant temperature	Coolant temperature sensor
Air-fuel ratio feedback compensation *6	Exhaust gas residual oxygen concentration	O ₂ sensor

Fuel control during normal driving

In synchronous injection during normal driving, fuel is injected on a cylinder-by-cylinder basis when all of the conditions below are met:

- ① Other than the stop mode
- ② Cylinder identification completed
- ③ Other than overrun

To determine the injection timing, the ECU calculates the injection timing through the use of the 3D control map provided in the ECU, which is based on the throttle position and the engine speed.

The injection duration is based on the basic injection duration (obtained through the throttle position, intake air pressure, and engine speed) to which injection duration compensation (based on the signals from various sensors such as the intake temperature sensor, atmospheric pressure sensor, and O₂ sensor) is added to determine the final injection duration. As a result, fuel is supplied to the cylinders.

- Normal synchronous injection

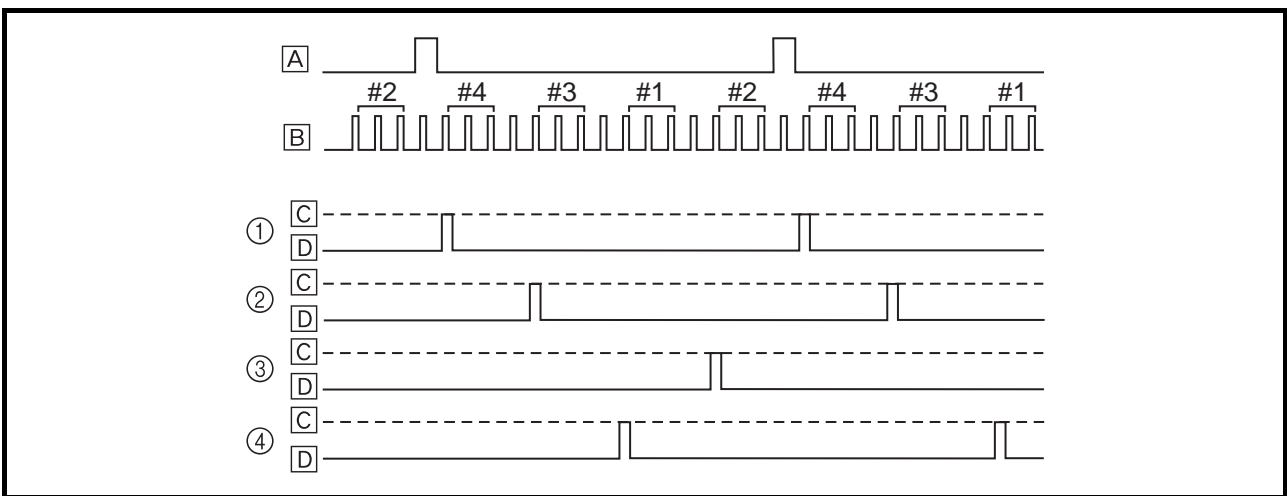

- ① Injector #1
- ② Injector #2
- ③ Injector #3
- ④ Injector #4
- A Cylinder identification signal
- B Crankshaft identification signal
- C Injection
- D Stop

- Fuel injection control during normal driving

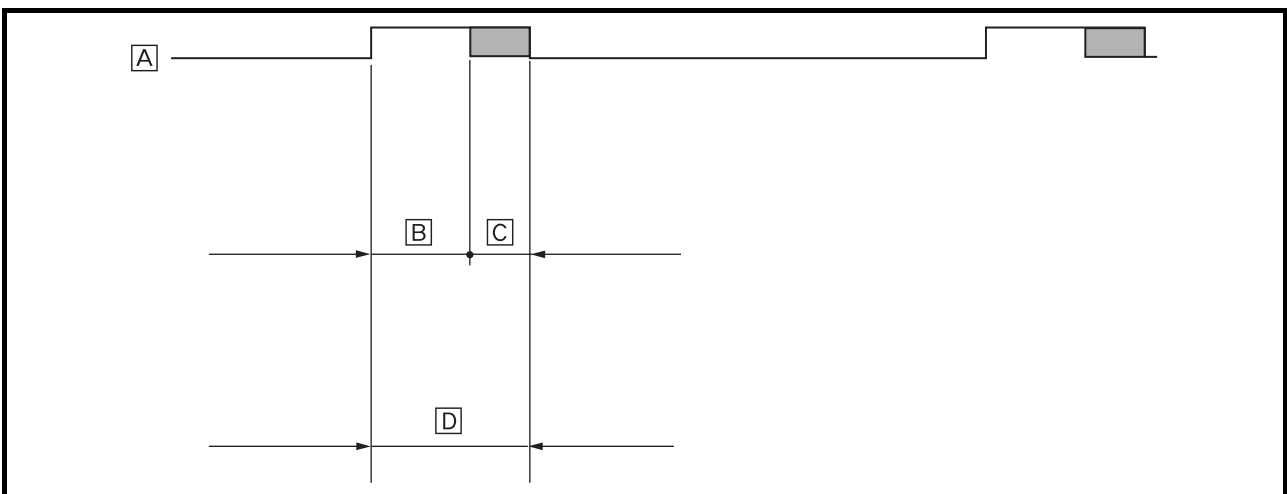

- A #1 cylinder fuel injection timing
- B Basic injection duration
- C Various types of fuel injection duration compensations
- D Synchronous injection duration (final injection duration)

Fuel injection compensation control

- Starting injection control

The coolant temperature is used for determining the injection duration in order to ensure proper start ability. To suit the engine's operating conditions, the starting injection duration is determined by applying a starting compensation coefficient to the basic injection duration, which forms the basis of the injection duration.

(Starting injection duration = basic injection duration × injection compensation coefficient)

During starting, injection cylinder control is effected together with injection duration compensation. To effect injection cylinder control, the injectors of all the cylinders inject fuel only once immediately upon receiving the signals from the sensors during the cranking of the engine. This is called asynchronous injection, in contrast to synchronous injection, which is a normal cylinder injection that is effected on a cylinder-by-cylinder basis.

After the asynchronous injection is completed, and until the ECU receives signals from the cylinder identification sensor, the injectors are actuated in pairs in sync with the signals from the crankshaft position sensor: cylinders #1 and 4, and cylinders #2 and 3. Controlling both the injection duration and the injection cylinders in this manner enables a precise supply of fuel in accordance with the starting conditions of the engine.

- Starting injection duration

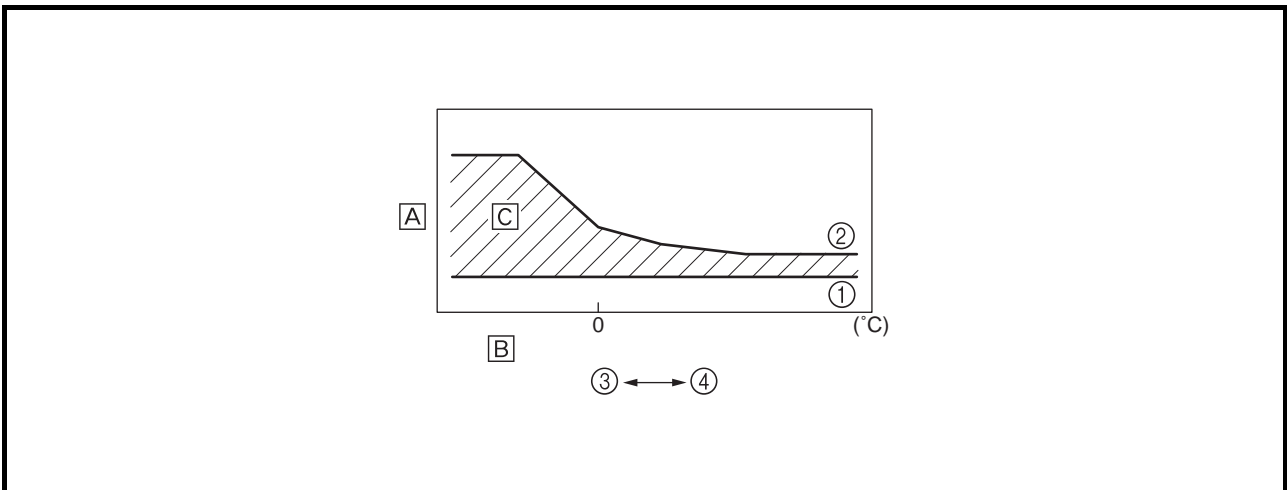

- ① Basic injection duration
- ② After-start compensation injection duration
- ③ Low
- ④ High
- Ⓐ Injection duration
- Ⓑ Coolant temperature
- Ⓒ Extended duration

• Starting cylinder control

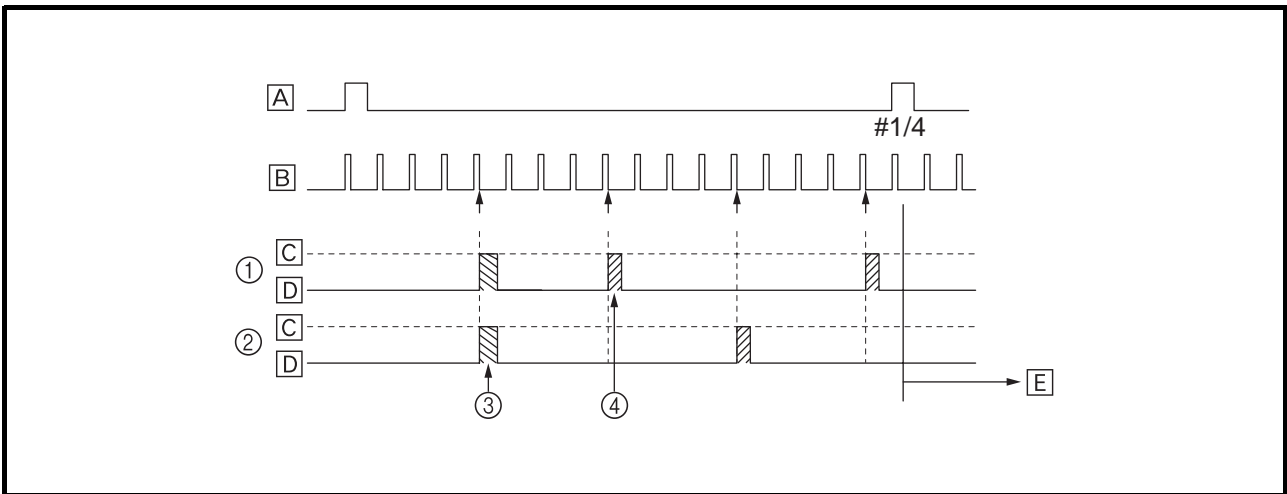

- ① Injectors #1,4
- ② Injectors #2,3
- ③ Starting asynchronous injection
- ④ Group injection
- Ⓐ Cylinder identification sensor
- Ⓑ Crankshaft position sensor
- Ⓒ Injection
- Ⓓ Stop
- Ⓔ Synchronous injection

• After-start enrichment

After-start enrichment provides enrichment compensation during a prescribed duration following the starting (firing) of the engine. While the amount of fuel enrichment is determined by the after-start enrichment coefficient, the coefficient varies by the coolant temperature. Although the coolant temperature determines the initial starting enrichment coefficient, the coefficient subsequently changes in accordance with the damping factor. The enrichment ratio is the highest immediately after the engine is started, and diminishes gradually. The enrichment of fuel in this manner ensures a stable engine operation immediately after the engine is started.

Changes in compensation coefficient and compensation injection duration

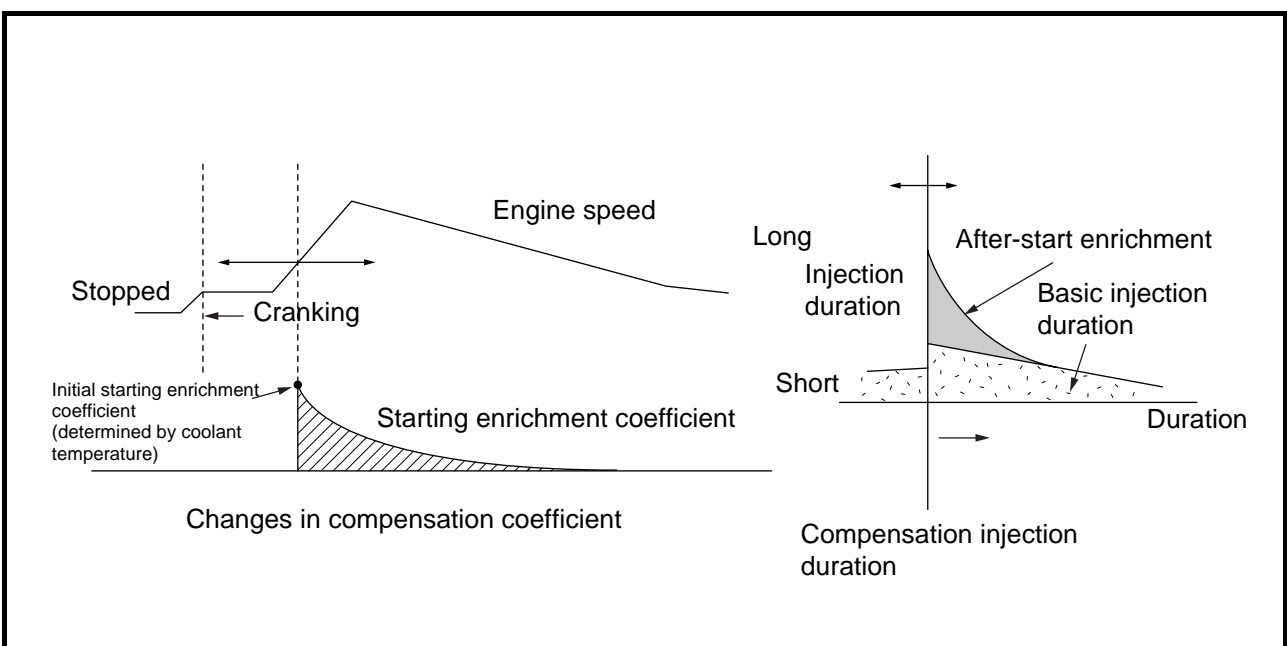

- Warm-up enrichment

When the coolant temperature is low, a warm-up coefficient is applied in accordance with the signals from the coolant temperature sensor in order to effect fuel enrichment. Because the coolant temperature determines the coefficient, the coefficient changes with the fluctuations in the coolant temperature. The coefficient increases with the decrease in the coolant temperature, and decreases with the increase in the coolant temperature. The ratio of fuel enrichment also changes with the changes in the coefficient.

Changes in compensation coefficient and compensation injection duration

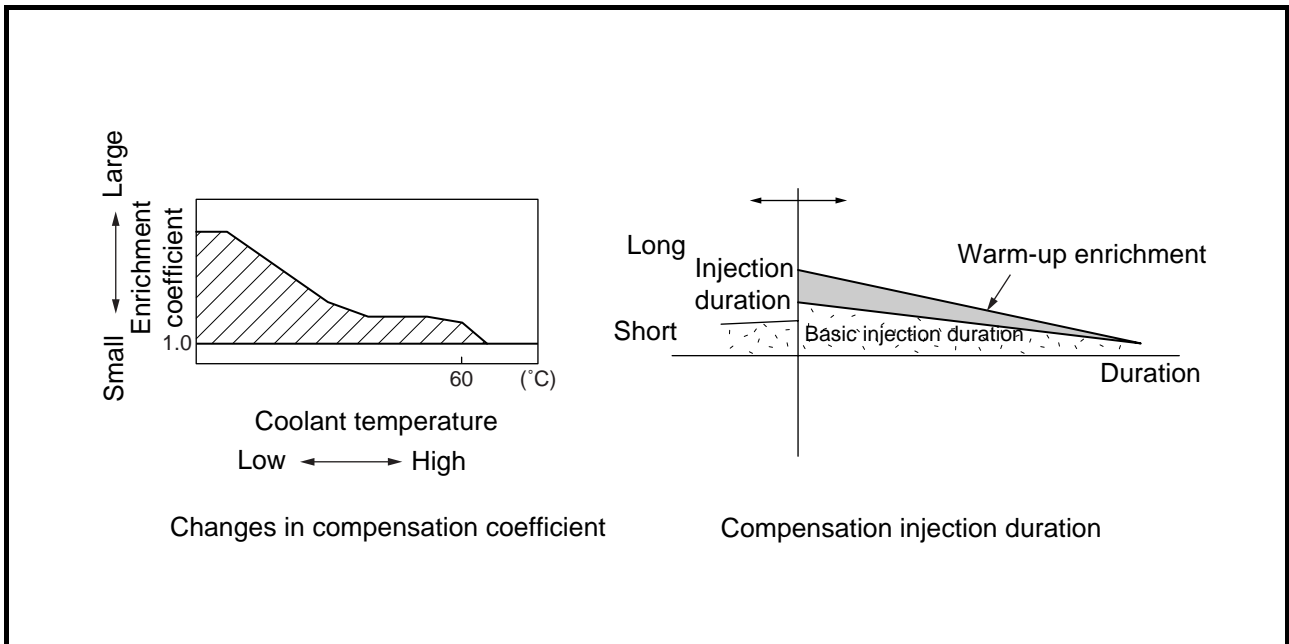

- Acceleration enrichment

Acceleration enrichment is provided in accordance with the signals from the throttle position sensor. As the rider operates the accelerator to accelerate the motorcycle from a constant speed, the throttle position sensor actuates in unison with the accelerator. The ECU interprets that acceleration has taken place through the throttle position sensor signal and executes acceleration enrichment. The enrichment volume is determined by the acceleration enrichment coefficient. The coefficient increases with the changes in the throttle position sensor, which also increases the actual enrichment volume. The enrichment volume is executed in accordance with the acceleration enrichment coefficient when the movement of the throttle position sensor has met the acceleration condition as defined by the ECU. Thereafter, the enrichment volume is regulated by the coefficient that changes in accordance with the damping rate.

(Acceleration injection duration = basic injection duration × acceleration compensation coefficient)

Changes in compensation coefficient and compensation injection duration

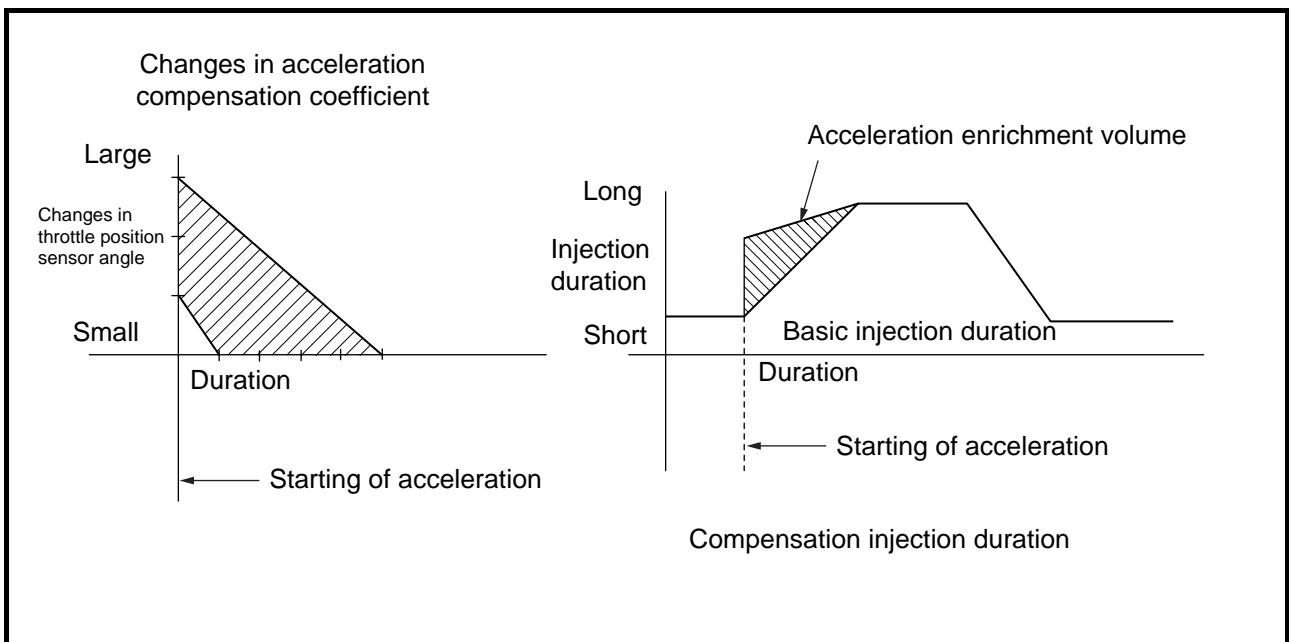

• Deceleration control

Deceleration control is effected in accordance with the signals from the throttle position sensor. As the rider operates the accelerator to decelerate the motorcycle that is in motion, the throttle position sensor acutates in unison with the accelerator. When the engine speed is greater than a prescribed value with the throttle fully closed (thus applying engine braking), the ECU executes a deceleration fuel cut-off. The injection of fuel to all the cylinders is stopped when fuel cut-off control is executed, thus improving fuel economy.

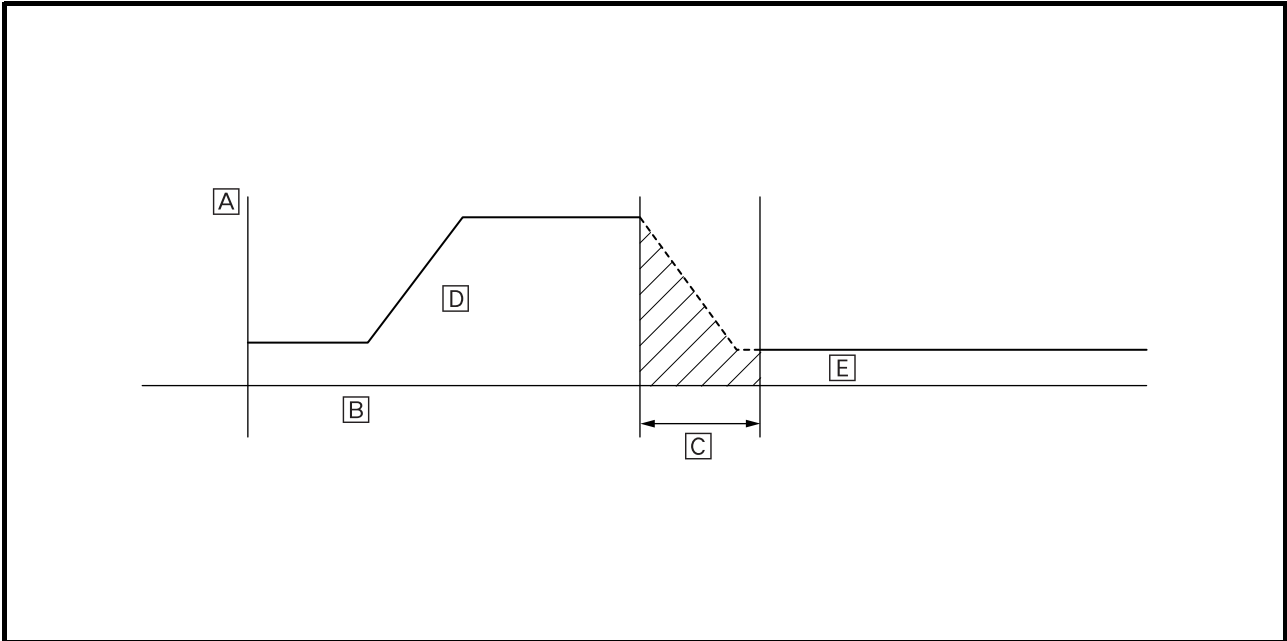

- A** Engine speed
- B** Duration
- C** Fuel cut-off control (stopping fuel injection)
- D** Basic injection duration
- E** Basic injection duration

• Over-revving control

This function effects fuel cut-off control when the engine speed becomes greater than the prescribed value. The fuel cut-off control regulates the engine speed by stopping the injection of fuel into two cylinders when the engine speed becomes greater than the specified value. If the engine speed increases further, this control stops the injection of fuel to all the cylinders. Thus, the over-revving control effects fuel cut-off control in two stages.

THREE-WAY CATALYTIC CONVERTER SYSTEM

System outline

This is a highly efficient exhaust gas cleaning system that effects air-fuel control through a joint effort by the FI system, O₂ sensor, and the three-way catalytic converter system. By effecting comprehensive control of the air-fuel ratio in this manner, this system reduces the CO, HC, and NO_x in the exhaust gases.

The FI system controls the mixture to an optimal air-fuel ratio (basic air-fuel ratio) that matches the operating condition of the engine in order to realize an ideal combustion.

Furthermore, an O₂ sensor that detects the concentration of oxygen that remains in the exhaust gas is provided in the exhaust pipe for the purpose of maximizing the performance of the three-way catalytic converter and to clean the exhaust gas at a high degree of efficiency. Based on this data, the ECU applies more precise compensation to the basic air-fuel ratio, in order to maintain the mixture in the vicinity of the stoichiometric air-fuel ratio of 14.7:1.

Through the joint effort of these control systems, the exhaust gas is cleaned in a highly efficient manner without sacrificing engine performance.

Three-way catalytic converter system diagram

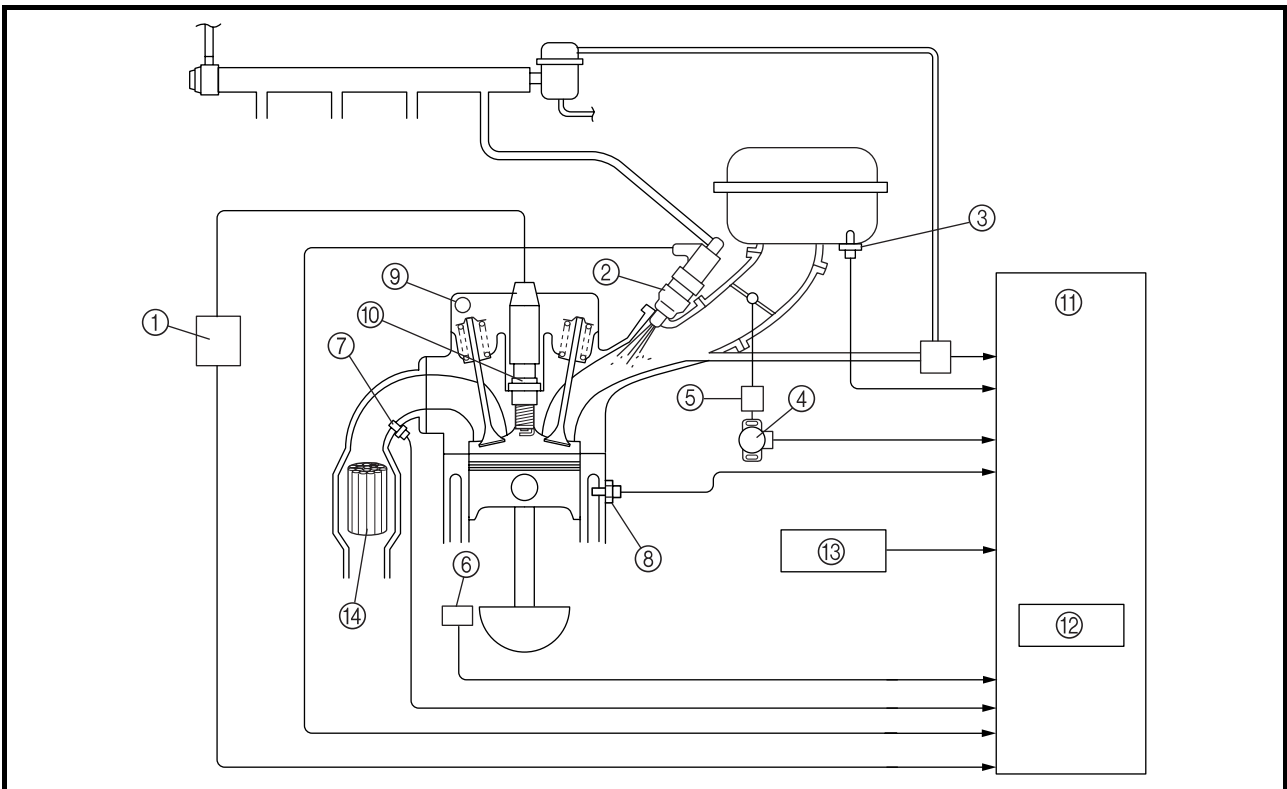

- | | | | |
|-----------------------------|------------------------------|----------------------------------|-------------------------------|
| ① Ignition coil | ⑤ Intake air pressure sensor | ⑨ Cylinder identification sensor | ⑫ Igniter |
| ② Injector | ⑥ Crankshaft position sensor | ⑩ Spark plug | ⑬ Atmospheric pressure sensor |
| ③ Intake temperature sensor | ⑦ O ₂ sensor | ⑪ ECU | ⑭ Catalytic converter |
| ④ Throttle position sensor | ⑧ Coolant temperature sensor | | |

Functions of components

	Equipment	Functions	Main components
Three-way catalytic converter system	Catalyzer (honeycomb type)	Simultaneously reduces CO, HC, and NOx emissions.	<ul style="list-style-type: none"> • Catalytic converter • Catalyst case
	Air-fuel compensation equipment	Reduces CO, HC, and NOx emissions. The catalyst primarily cleans the exhaust gases in order to ensure the stoichiometric air-fuel ratio.	<ul style="list-style-type: none"> • O₂ sensor • ECU
	Fuel cut-off equipment	Reduces CO and HC emissions, improves fuel economy, and cuts off fuel during deceleration.	<ul style="list-style-type: none"> • Throttle position sensor • ECU

Catalyst

Because the conditions in which NOx is generated are directly opposed to those of CO and HC, there is a limit to the extent to which the concentration levels of these harmful elements can be reduced in the combustion stage. Hence, the function of the catalyst is to clean the exhaust gas at a high degree of efficiency by removing CO, HC, and NOx in the exhaust stage.

This model has adopted a monolith type metallic catalyst with a honeycomb construction, which achieves a low exhaust resistance through the large surface area of the catalyst body (with a high level of cleaning efficiency).

Catalytic substances consisting of precious metals such as platinum and rhodium are adhered to the wall surface of these honeycomb cells, which are enclosed in the exhaust pipe. As the exhaust gas comes in contact with these catalytic substances, the chemical reactions of oxidation and reduction advance in order to clean the exhaust gas.

- The CO and HC oxidize with the oxidation function of platinum, and are converted into harmless carbon dioxide (CO₂) and water (H₂O), resulting in cleaner exhaust gases.

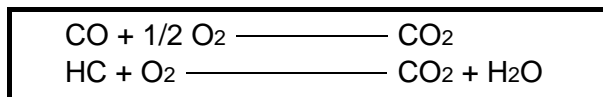

- The NOx is reduced by the reduction function of rhodium, which converts NOx into harmless nitrogen (N₂) and oxygen (O₂), resulting in cleaner exhaust gases.

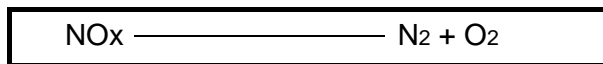

To clean the exhaust gases at a high rate of efficiency through the maximization of these catalytic capacities, it is necessary to maintain and control the mixture in the vicinity of the stoichiometric air-fuel ratio of (14.7:1) at all times. As a means of maintaining the stoichiometric ratio, this system has adopted an O₂ feedback compensation method that uses an O₂ sensor, which will be described in the next section.

Large amounts of both CO and HC are generated when the mixture is rich (as indicated by insufficient O₂ region ①). Conversely, large amounts of NO_x are generated when the mixture is lean (as indicated by excessive O₂ region ②). Under these conflicting characteristics, the system maintains the mixture within an extremely narrow range ③ of stoichiometric ratio (14.7:1). As a result, the function of the catalyst is maximized, making it possible to clean the exhaust gases at a high degree of efficiency.

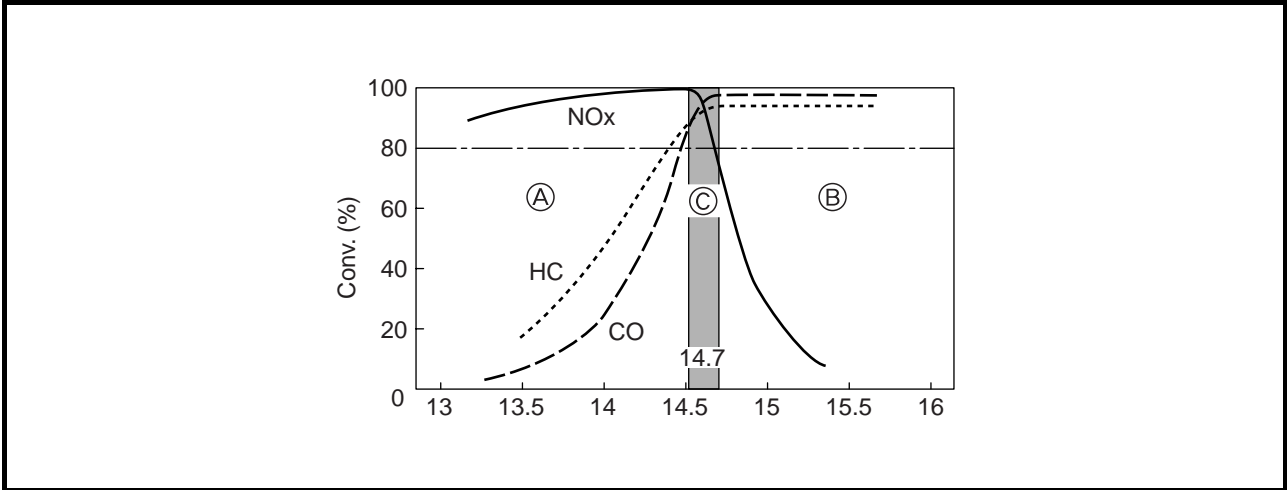

Air-fuel ratio compensation equipment

An O₂ sensor is provided in the exhaust pipe upstream of the catalyst, to enable the catalyst to operate at a high degree of efficiency. The O₂ sensor detects the level of concentration of the oxygen remaining in the exhaust gases.

A high level of oxygen concentration signifies a lean air-fuel mixture, and when the O₂ sensor detects this condition, it inputs a lean signal into the ECU. Conversely, when the level of oxygen concentration is low, the O₂ sensor inputs a rich signal into the ECU.

The ECU system applies minute corrections to these signals so that the injection volume (the duration of the current applied to the injectors) comes to be within the vicinity of the stoichiometric ratio. Thus, the system is designed to maximize the cleaning function of the catalyst.

Feedback compensation circuit

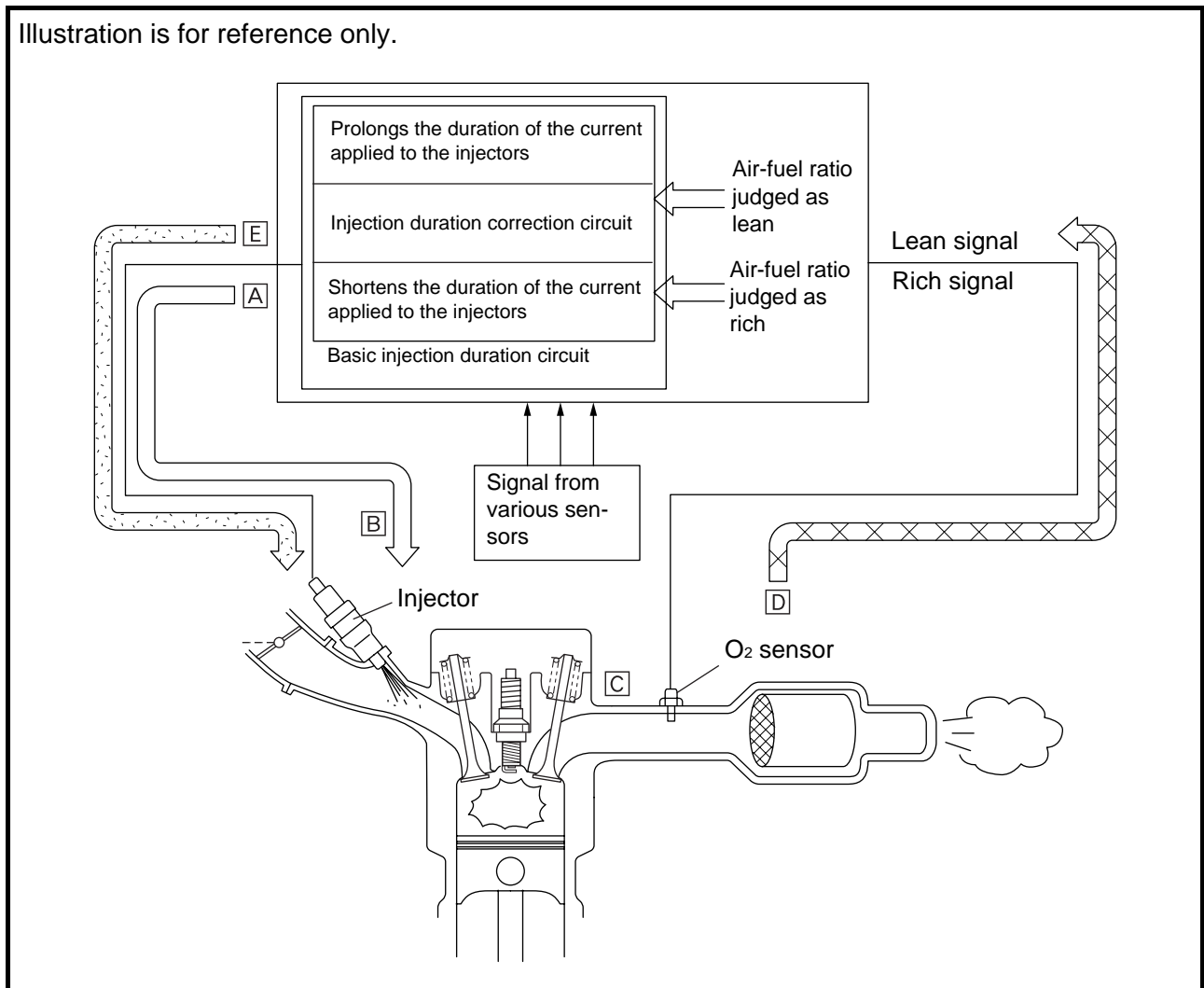

- [A] The ECU determines the basic injection volume based on the signals that are input from various sensors and regulates the duration of the current applied to the injectors.
- [B] Current is applied to the injectors, enabling them to inject fuel.
- [C] The engine undergoes combustion and exhaust.
- [D] The O₂ sensor detects the level of oxygen concentration in the exhaust gases, and outputs a lean or rich air-fuel ratio signal in accordance with the detected data.
- [E] In accordance with the signals from the O₂ sensor, the ECU applies minute corrections to the basic injection duration, determines the subsequent injection volume, and provides instructions to the injectors. The above processes are repeated in order to maintain the mixture at the stoichiometric ratio.

AIR INDUCTION SYSTEM

The air induction system (AI system) introduces fresh air into the exhaust port in order to burn the unburned gas (which is present in the exhaust gas) in the exhaust pipe. The burning of the unburned gases in this manner enhances the efficiency of the catalyst and results in cleaner exhaust gases.

The AI system takes a portion of the air from the air cleaner, sends it to the reed valve via the air cut-off valve, and introduces it directly into the exhaust port through the reed valve.

The air cut-off valve is controlled by the signals from the ECU in accordance with the combustion conditions. Ordinarily, the air cut-off valve opens to allow the air to flow during idle and closes to cut off the flow when the motorcycle is being driven. However, if the coolant temperature is below the specified value, the air cut-off valve remains open and allows the air to flow into the exhaust pipe until the temperature becomes higher than the specified value.

The reed valve is provided on the cylinder head cover above the cylinders, and sends air to the exhaust pipe through the inside of the cylinder head.

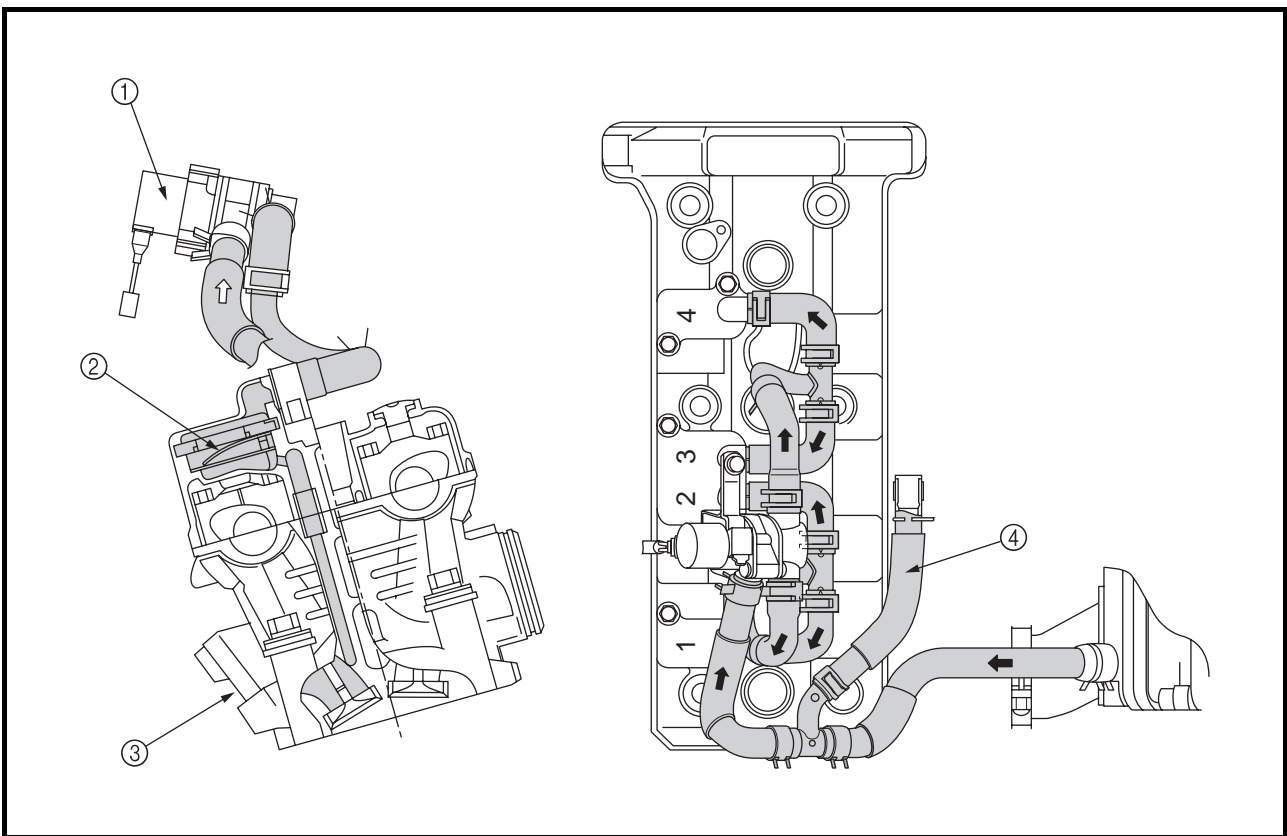

- ① Air cut-off valve
- ② Reed valve
- ③ Exhaust port
- ④ Resonator

COMPONENTS

1. Air cut-off valve

The air cut-off valve consists of a plunger that is mounted inside the core of a solenoid coil, and a valve at the end of the plunger for opening and closing the air passage. Due to the force of a spring, the valve is in constant contact with valve block A, and thus keeps the air passage open. As a result, the air from the air cleaner passes through the air passage and flows into the reed valves of the cylinders. When the current flows to the solenoid coil in accordance with a signal from the ECU, the plunger in the core becomes attracted towards the coil. When this attraction force overcomes the pressure of the spring, the valve is pulled in along with the plunger, comes in contact with valve block B, and closes the air passage. The ECU controls the operation of the air cut-off valve so that it operates in an optimal condition to suit the driving conditions.

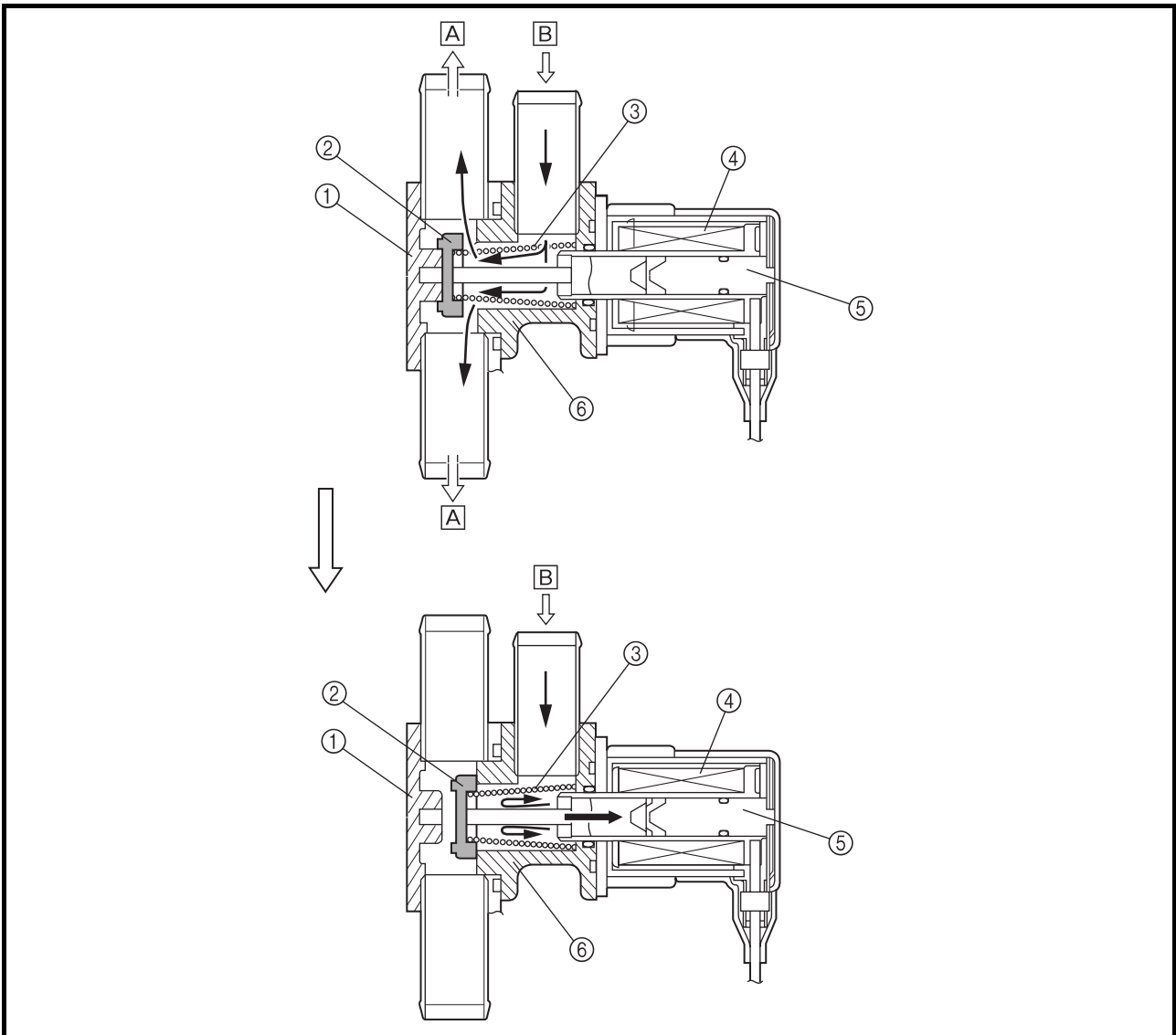

① Valve block A
② Valve

③ Spring
④ Coil

⑤ Core
⑥ Valve block B

A To reed valve
B From air cleaner

Instrument panel

Function indication

The indications of the self-diagnosis function can be checked and inspection operations can be performed through the use of the multi-function meter on the instrument panel.

Based on the signals received from the sensors, the ECU inputs the signals into the multi-function meter. Then, the conditions of the sensors appear on the clock and trip/odometer display of the multi-function meter.

1. ECU transmission data and meter display

Mode	ECU transmission data	Meter indication	Display description
Common to all modes	Vehicle speed	Trip meter	4 digits including decimals
	Engine warning indicator lamp	Indicator lamp	ON/OFF
	Self-diagnostic fault code	Clock LCD	Shows trouble code in numbers
Normal mode	Coolant temperature	Coolant temperature meter LCD	Coolant temperature
CO/DIAG mode selection	CO/DIAG selection	Clock LCD	Shows CO or DIAG in letters
CO adjustment mode	CO adjustment cylinder No.	Clock LCD	Shows adjustment cylinder No. in numbers
	CO adjustment volume	Trip LCD	Shows adjustment volume in numbers
DIAG mode	Diagnostic code	Clock LCD	Shows diagnostic code in numbers
	Diagnosis sensor value	Trip LCD	Shows data for sensors

Note: If the exchange of data between the ECU and the meters is abnormal, the clock LCD shows error "Er-1~4". The clock LCD reverts to showing the time after the error has been corrected.

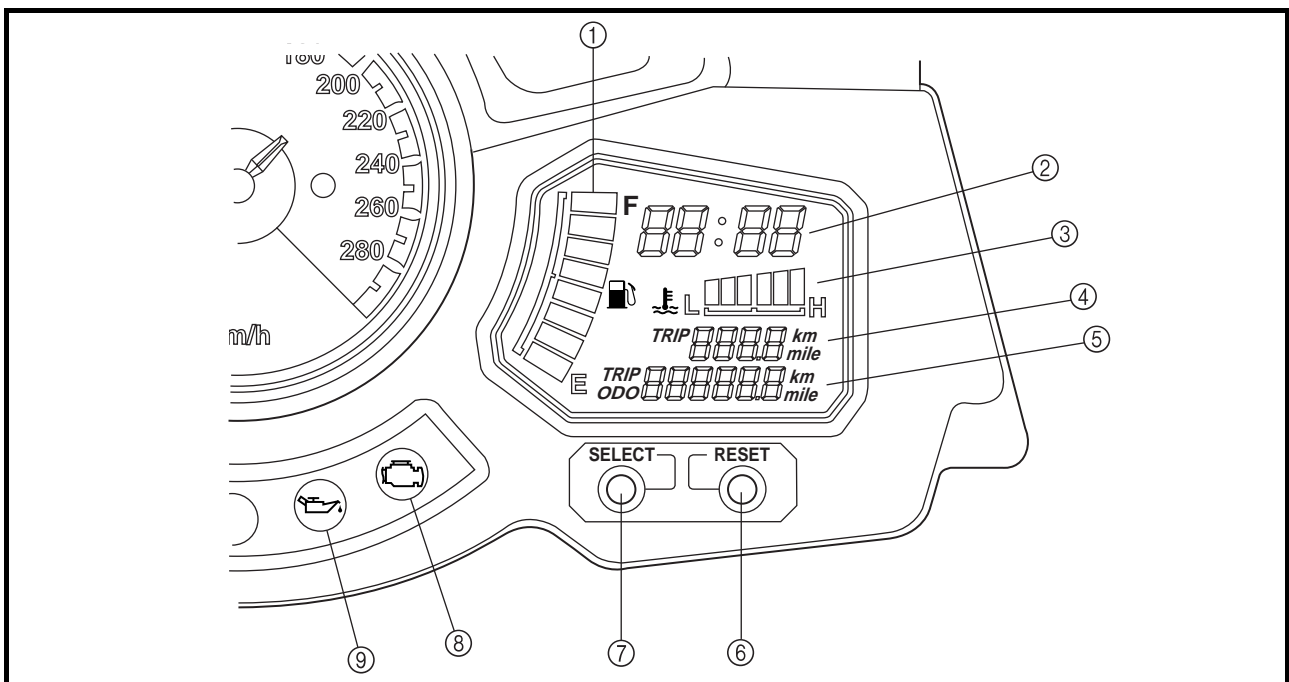

- ① Fuel meter
- ② Clock
- ③ Coolant temperature meter
- ④ TRIP meter
- ⑤ TRIP/ODO meter
- ⑥ RESET button
- ⑦ SELECT button
- ⑧ Engine trouble warning light
- ⑨ Oil level warning light

2. DIAG and CO mode inspection and adjustment (multi-function meter)

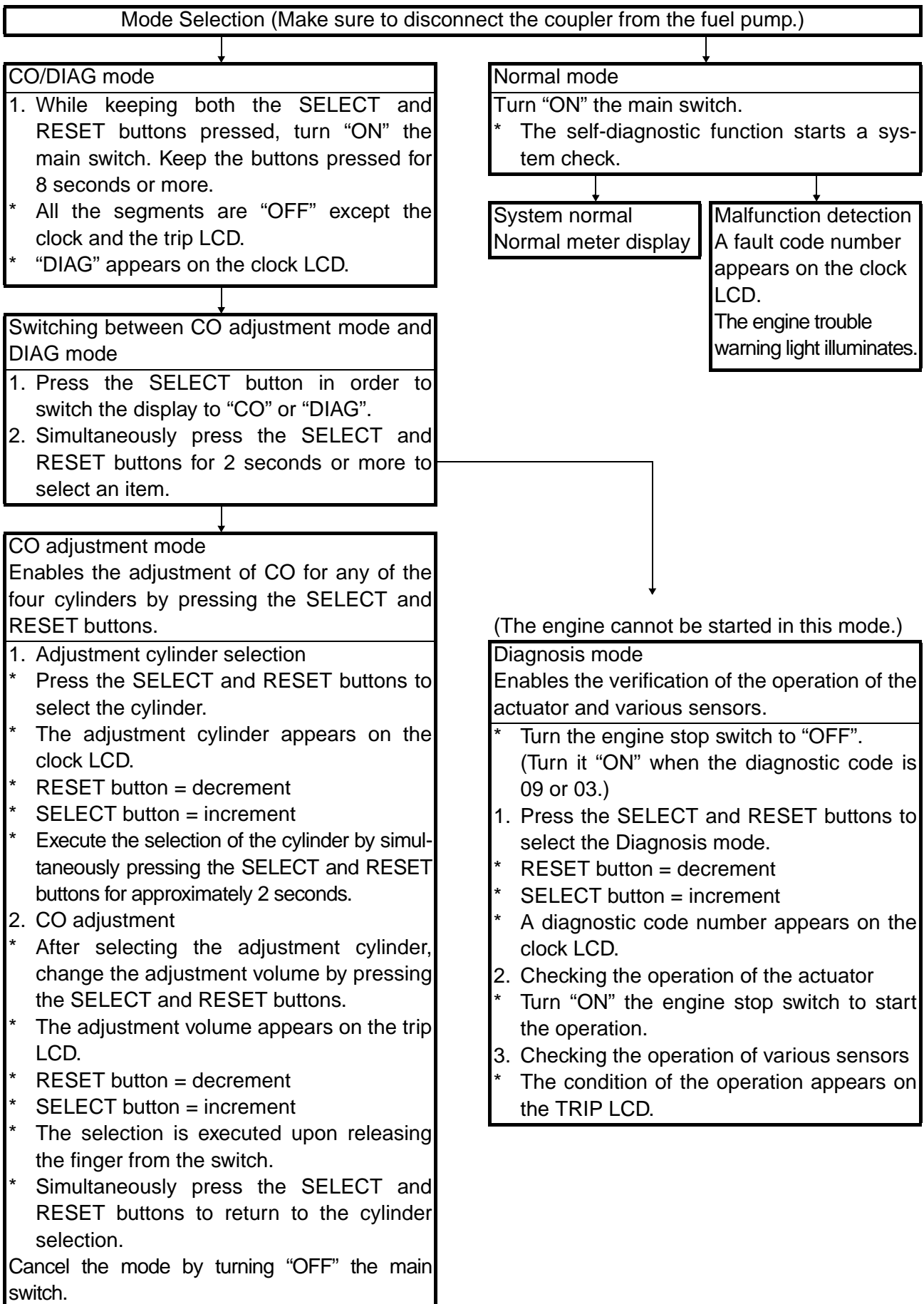

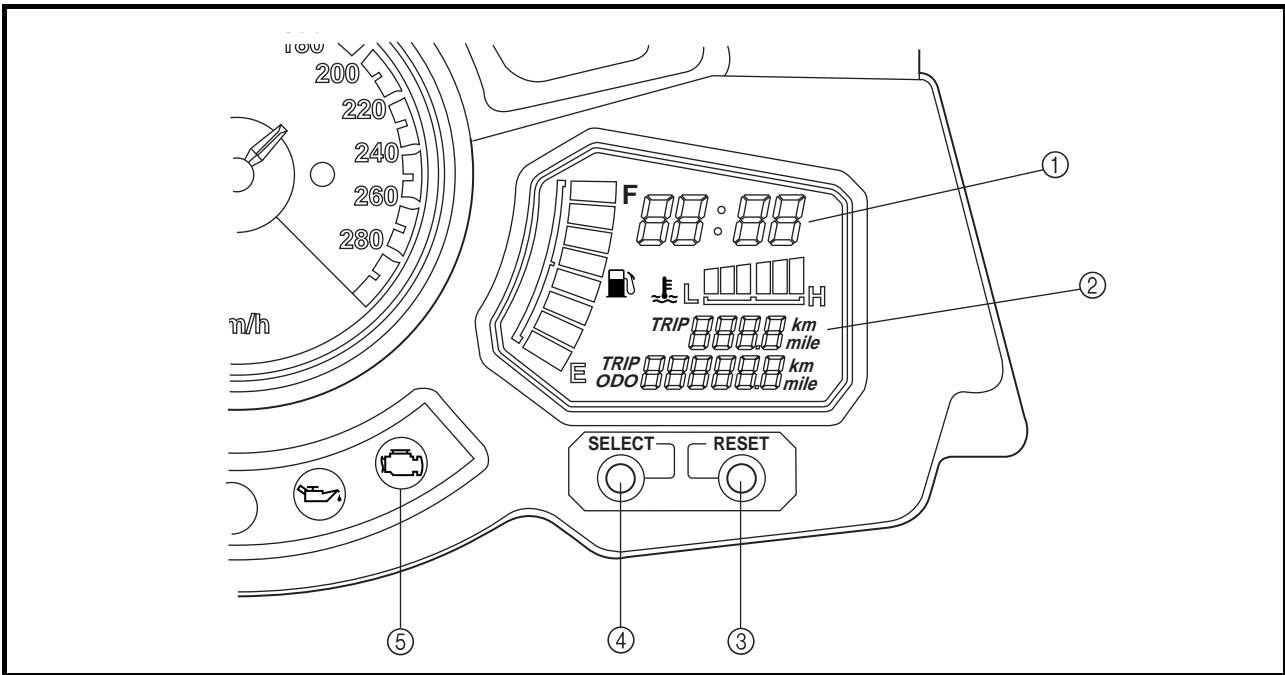

- ① Clock
- ② TRIP meter
- ③ RESET button
- ④ SELECT button
- ⑤ Engine trouble warning light

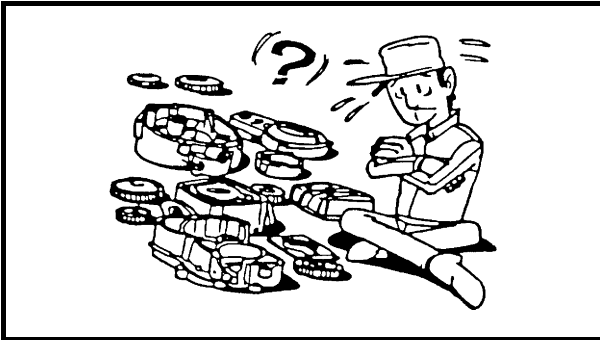
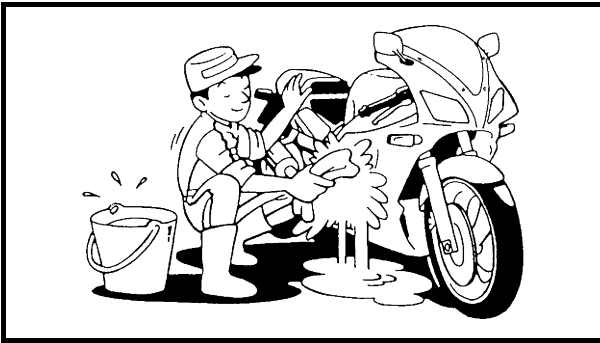

EAS00020

**IMPORTANT INFORMATION
PREPARATION FOR REMOVAL AND
DISASSEMBLY**

1. Before removal and disassembly, remove all dirt, mud, dust and foreign material.
2. Use only the proper tools and cleaning equipment. Refer to the "SPECIAL TOOLS".
3. When disassembling, always keep mated parts together. This includes gears, cylinders, pistons and other parts that have been "mated" through normal wear. Mated parts must always be reused or replaced as an assembly.
4. During disassembly, clean all of the parts and place them in trays in the order of disassembly. This will speed up assembly and allow for the correct installation of all parts.
5. Keep all parts away from any source of fire.

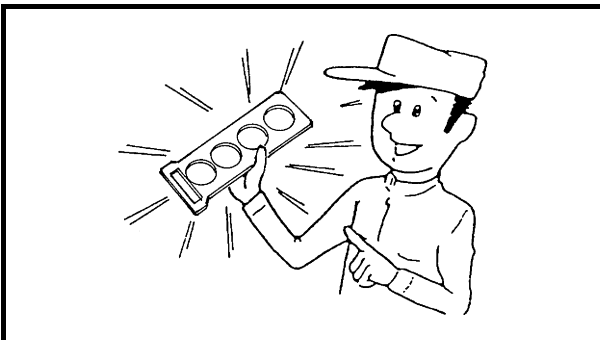

EAS00021

REPLACEMENT PARTS

Use only genuine Yamaha parts for all replacements. Use oil and grease recommended by Yamaha for all lubrication jobs. Other brands may be similar in function and appearance, but inferior in quality.

EAS00022

GASKETS, OIL SEALS AND O-RINGS

1. When overhauling the engine, replace all gaskets, seals and O-rings. All gasket surfaces, oil seal lips and O-rings must be cleaned.
2. During reassembly, properly oil all mating parts and bearings and lubricate the oil seal lips with grease.

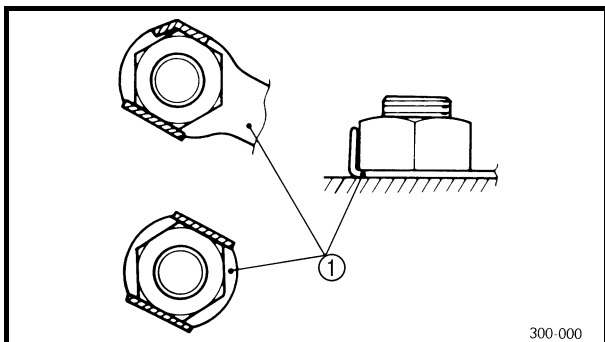

EAS00023

LOCK WASHERS/PLATES AND COTTER PINS

After removal, replace all lock washers/plates ① and cotter pins. After the bolt or nut has been tightened to specification, bend the lock tabs along a flat of the bolt or nut.

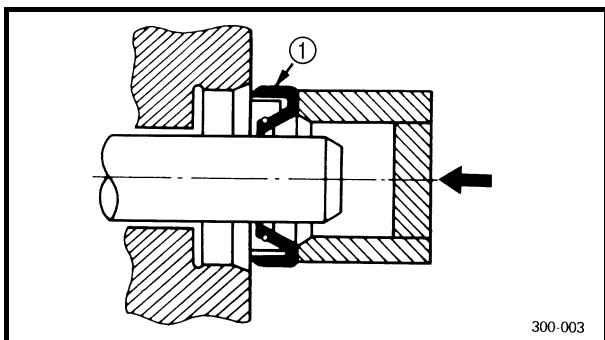

EAS00024

BEARINGS AND OIL SEALS

Install bearings and oil seals so that the manufacturer's marks or numbers are visible. When installing oil seals, lubricate the oil seal lips with a light coat of lithium soap base grease. Oil bearings liberally when installing, if appropriate.

① Oil seal

CAUTION:

Do not spin the bearing with compressed air because this will damage the bearing surfaces.

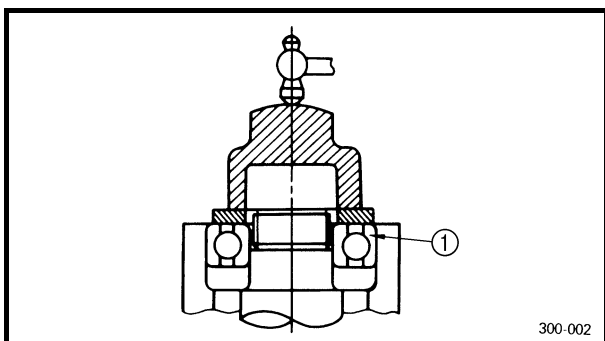

① Bearing

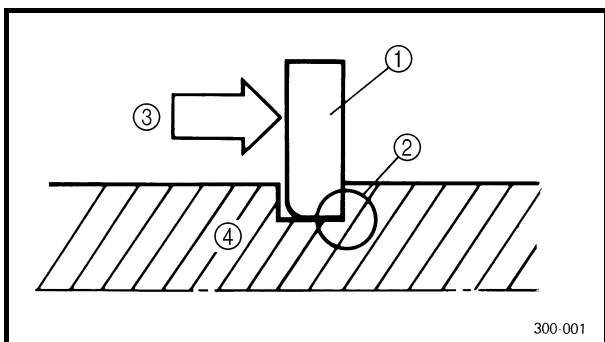

EAS00025

CIRCLIPS

Before reassembly, check all circlips carefully and replace damaged or distorted circlips. Always replace piston pin clips after one use. When installing a circlip ①, make sure the sharp-edged corner ② is positioned opposite the thrust ③ that the circlip receives.

④ Shaft

EAS00026

CHECKING THE CONNECTIONS

Check the leads, couplers, and connectors for stains, rust, moisture, etc.

1. Disconnect:

- lead
- coupler
- connector

2. Check:

- lead
- coupler
- connector

Moisture → Dry with an air blower.

Rust/stains → Connect and disconnect several times.

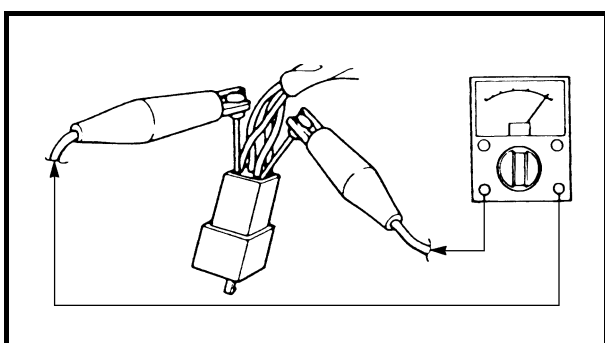
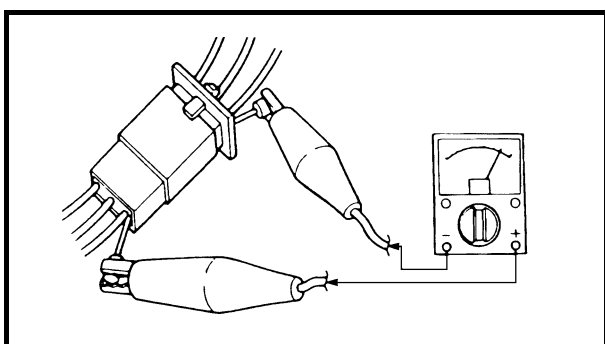
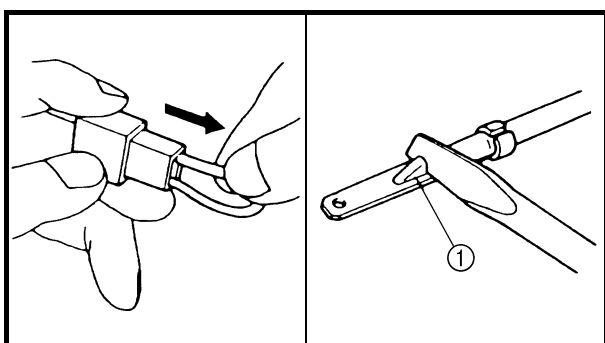
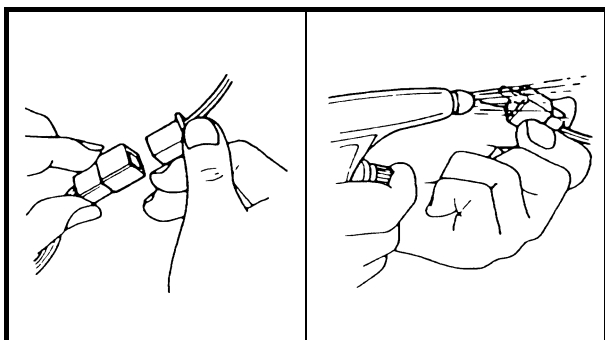

3. Check:

- all connections

Loose connection → Connect properly.

NOTE:

If the pin ① on the terminal is flattened, bend it up.

4. Connect:

- lead
- coupler
- connector

NOTE:

Make sure all connections are tight.

5. Check:

- continuity (with the pocket tester)



**Pocket tester
90890-03112**

NOTE:

- If there is no continuity, clean the terminals.
- When checking the wire harness, perform steps (1) to (3).
- As a quick remedy, use a contact revitalizer available at most part stores.

EAS00027

SPECIAL TOOLS

The following special tools are necessary for complete and accurate tune-up and assembly. Use only the appropriate special tools as this will help prevent damage caused by the use of inappropriate tools or improvised techniques. Special tools, part numbers or both may differ depending on the country.

When placing an order, refer to the list provided below to avoid any mistakes.

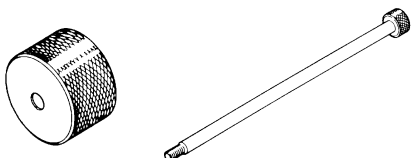
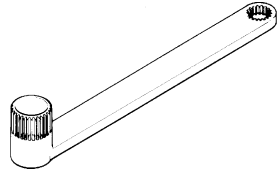
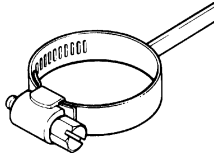
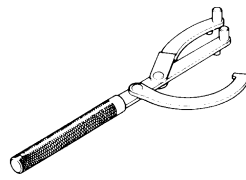
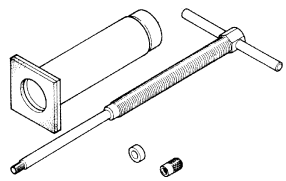
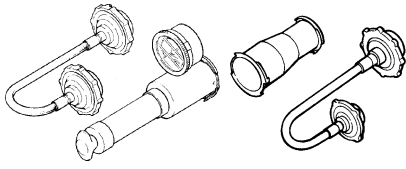
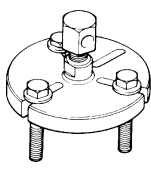
Tool No.	Tool name/Function	Illustration
Bolt 90890-01083 Weight 90890-01084	Slide hammer bolt Weight These tools are needed to remove the main axle assembly.	
90890-01229	Coupling gear/middle shaft tool This tool is needed when removing or installing the coupling gear nut.	
90890-01230	Final gear backlash band This tool is needed when measuring the final gear backlash.	
90890-01235	Rotor holding tool This tool is needed to hold the camshaft sprocket when loosen or tighten the camshaft sprocket bolts.	
90890-01304	Piston pin puller set This tool is used to remove the piston pin.	
Tester 90890-01325 Adapter 90890-01352	Radiator cap tester Radiator cap tester adapter This tester and its adapter are needed for checking the cooling system.	
Puller 90890-01362	Flywheel puller This tool is needed to remove the rotor.	

SPECIAL TOOLS



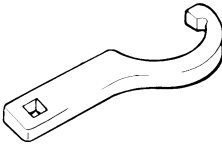
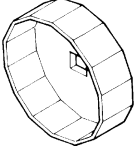
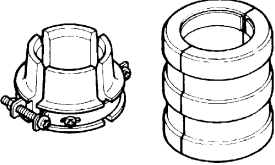
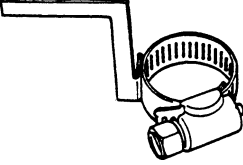
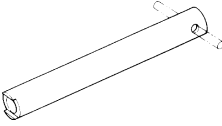
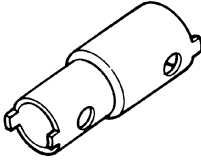
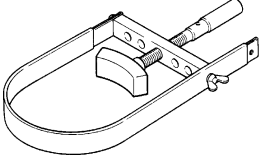
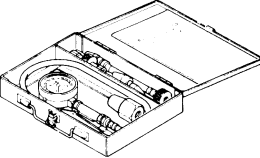

Tool No.	Tool name/Function	Illustration
90890-01403	<p>Steering nut wrench</p> <p>This tool is needed to loosen and tighten the steering stem ring nut.</p>	
90890-01426	<p>Oil filter wrench</p> <p>This tool is needed to remove and install the oil filter.</p>	
90890-01442	<p>Fork seal driver</p> <p>This tool is needed when installing the slide metal, oil seal and dust seal into the fork.</p>	
90890-01467	<p>Gear lash measurement tool</p> <p>This tool is needed when measuring the middle gear backlash.</p>	
90890-01447	<p>Damper rod holder</p> <p>This tool is needed to hold the damper rod assembly when loosen or tighten the damper rod assembly bolt.</p>	
90890-01471	<p>Pivot shaft wrench</p> <p>This tool is needed to loosen or tighten the spacer bolt.</p>	
90890-01701	<p>Sheave holder</p> <p>This tool is needed to hold the rotor when removing or installing the rotor bolt, starter clutch and pickup coil rotor bolt.</p>	
<p>Gauge 90890-03081 Adapter 90890-04136</p>	<p>Compression gauge Compression gauge adapter</p> <p>These tools are needed to measure engine compression.</p>	

SPECIAL TOOLS

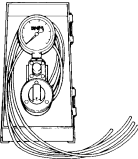
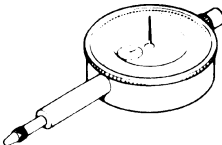
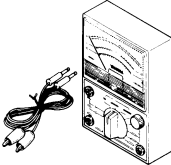
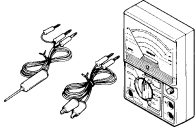
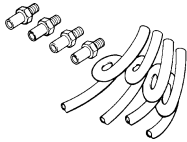
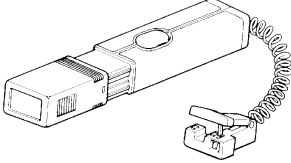
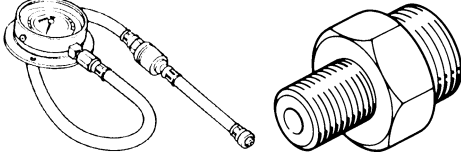
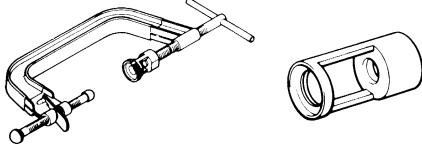

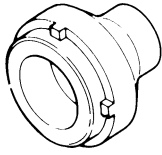
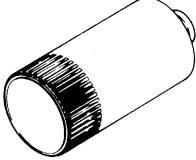
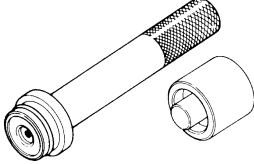
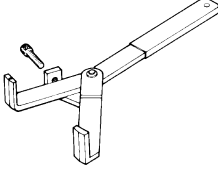
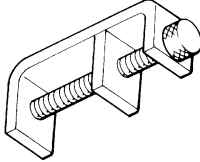
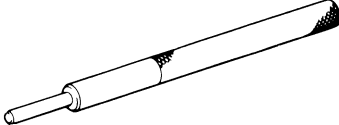
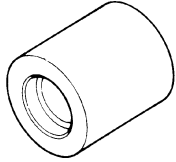
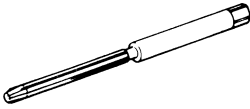
Tool No.	Tool name/Function	Illustration
90890-03094	Vacuum gauge This gauge is needed for throttle bodies synchronization.	
90890-03097	Dial gauge This tool is used to measure the middle gear backlash.	
90890-03112	Pocket tester This instrument is needed for checking the electrical system.	
90890-03132	Pocket tester This instrument is needed for checking the engine oil temperature.	
90890-03134	Exhaust attachment This tool is needed for checking the CO.	
90890-03141	Timing light This tool is necessary for checking ignition timing.	
Gauge 90890-03153 Oil pressure adaptor B 90890-03124	Pressure gauge Oil pressure adaptor B These tools are needed to measure engine oil pressure.	
Compressor 90890-04019 Attachment 90890-04108	Valve spring compressor Valve spring compressor attachment These tools are needed to remove and install the valve assemblies.	

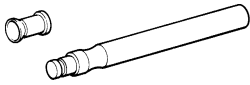
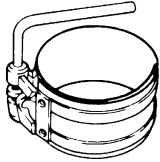
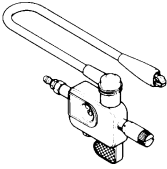
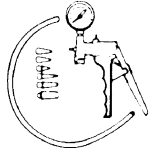
Tool No.	Tool name/Function	Illustration
90890-04050	<p>Bearing retainer wrench</p> <p>This tool is needed when removing or installing the final drive housing bearing retainer.</p>	
90890-04057	<p>Bearing retainer wrench</p> <p>This tool is needed when removing or installing the middle drive shaft bearing retainer.</p>	
<p>Driver 90890-04058 Installer 90890-04078</p>	<p>Middle driven shaft bearing driver Mechanical seal installer</p> <p>These tools are needed to install the water pump seal.</p>	
90890-04086	<p>Universal clutch holder</p> <p>This tool is needed to hold the clutch when removing or installing the clutch boss nut.</p>	
90890-04090	<p>Damper spring compressor</p> <p>This tool is needed when removing or installing the damper spring.</p>	
90890-04097	<p>Valve guide remover (5 mm)</p> <p>This tool is needed to remove and install the valve guide.</p>	
90890-04098	<p>Valve guide installer (5 mm)</p> <p>This tool is needed to install the valve guide.</p>	
90890-04099	<p>Valve guide reamer (5 mm)</p> <p>This tool is needed to rebores the new valve guide.</p>	

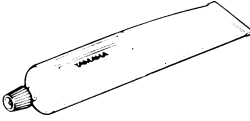
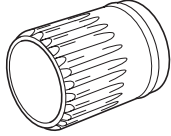
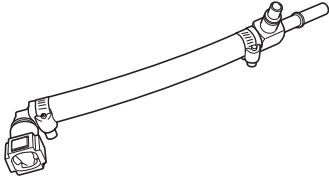
Tool No.	Tool name/Function	Illustration
90890-04101	<p>Valve lapper</p> <p>This tool is needed to remove and install the valve lifter.</p>	
90890-05158	<p>Piston ring compressor</p> <p>This tool is used to compress the piston rings when installing the piston into the cylinder.</p>	
90890-06754	<p>Ignition checker</p> <p>This tool is used to check the ignition system components.</p>	
90890-06756	<p>Vacuum/pressure pump gauge set</p> <p>This tool used to measure the vacuum pressure.</p>	
90890-06760	<p>Engine tachometer</p> <p>This tool is needed for observing engine rpm.</p>	
90890-85505	<p>Yamaha Bond No. 1215</p> <p>This sealant (bond) is used on crank-case mating surfaces, etc.</p>	
90890-04140	<p>Bearing retainer wrench</p> <p>This tool is needed when removing or installing the middle driven shaft bearing retainer.</p>	
90890-03176	<p>Fuel pressure adapter</p> <p>This tool is needed to measure fuel pressure.</p>	



SPEC

2

CHAPTER 2 SPECIFICATIONS

GENERAL SPECIFICATIONS	2-1
ENGINE SPECIFICATIONS	2-2
CHASSIS SPECIFICATIONS	2-11
ELECTRICAL SPECIFICATIONS	2-15
CONVERSION TABLE	2-18
GENERAL TIGHTENING TORQUE SPECIFICATIONS	2-18
TIGHTENING TORQUES	2-19
ENGINE TIGHTENING TORQUES	2-19
CHASSIS TIGHTENING TORQUES	2-23
LUBRICATION POINTS AND LUBRICANT TYPES	2-25
ENGINE LUBRICATION POINTS AND LUBRICANT TYPES	2-25
CHASSIS LUBRICATION POINTS AND LUBRICANT TYPES	2-27
OIL FLOW DIAGRAMS	2-28
COOLING SYSTEM DIAGRAMS	2-38
CABLE ROUTING	2-42



SPECIFICATIONS

GENERAL SPECIFICATIONS

Item	Standard	Limit
Model code	5JW1 (for Europe) 5JW2 (for F) 5JW3 (for Oceania)	---- ---- ----
Dimensions		
Overall length	2,195 mm	----
Overall width	760 mm	----
Overall height	1,420 mm	----
Seat height	805 mm	----
Wheelbase	1,515 mm	----
Minimum ground clearance	135 mm	----
Minimum turning radius	3,100 mm	----
Weight		
Wet (with oil and a full fuel tank)	268 kg	----
Dry (without oil and fuel)	237 kg	----
Maximum load (total of cargo, rider, passenger, and accessories)	208 kg	----



ENGINE SPECIFICATIONS

Item	Standard	Limit
Engine		
Engine type	Liquid-cooled, 4-stroke, DOHC	----
Displacement	1,298 cm ³	----
Cylinder arrangement	Forward-inclined parallel 4-cylinder	----
Bore × stroke	79.0 × 66.2 mm	----
Compression ratio	10.8 : 1	----
Engine idling speed	1,000 ~ 1,100 r/min	----
Vacuum pressure at engine idling speed	33.3 kPa (250 mm Hg)	----
Standard compression pressure (at sea level)	1,600 kPa (16 kg/cm ² , 16 bar) at 400 r/min	----
Fuel		
Recommended fuel	Regular unleaded gasoline	----
Fuel tank capacity		
Total (including reserve)	25 L	----
Reserve only	5 L	----
Engine oil		
Lubrication system	Wet sump	----
Recommended oil		
	SAE 20W40SE	----
	SAE 10W40SE	----
<p>Temp. °C</p> <p>-20 -10 0 10 20 30 40</p> <p>10W/40</p> <p>20W/40</p>		
Quantity		
Total amount	4.9 L	----
Without oil filter cartridge replacement	3.8 L	----
With oil filter cartridge replacement	4 L	----
Oil pressure (hot)	30 kPa at 1,000 r/min (0.30 kg/cm ² , 0.30 bar) at 1,000 r/min	----
Relief valve opening pressure	490 ~ 570 kPa (4.90 ~ 5.70 kg/cm ² , 4.90 ~ 5.70 bar)	----
Final gear oil		
Recommended oil	Shaft drive gear oil (Part No. : 9079E-SH001-00)	----
Total amount	0.2 L	----

ENGINE SPECIFICATIONS

SPEC



Item	Standard	Limit
Oil filter		
Oil filter type	Formed type	----
Bypass valve opening pressure	78.4 ~ 117.6 kPa (0.78 ~ 1.18 kg/cm ² , 0.78 ~ 1.18 bar)	----
Oil pump		
Oil pump type	Trochoid	----
Inner-rotor-to-outer-rotor-tip clearance	0.09 ~ 0.15 mm	0.23 mm
Outer-rotor-to-oil-pump-housing clearance	0.03 ~ 0.08 mm	0.15 mm
Cooling system		
Radiator capacity	3.2 L	----
Radiator cap opening pressure	93.3 ~ 122.7 kPa (0.93 ~ 1.23 kg/cm ² , 0.93 ~ 1.23 bar)	----
Valve relief pressure	4.9 kPa (0.05 kg/cm ² , 0.05 bar)	----
Radiator core		
Width	360 mm	----
Height	295.8 mm	----
Depth	27 mm	----
Coolant reservoir		
Capacity	0.485 L	----
<From low to full level>	0.15 L	----
Water pump		
Water pump type	Single-suction centrifugal pump	----
Reduction ratio	75/48 × 25/28 (1.395)	----
Max. impeller shaft tilt	----	0.15 mm
Starting system type	Electric starter	----
Spark plugs		
Model (manufacturer) × quantity	CR8E/U24ESR-N (NGK/DENSO) × 4	----
Spark plug gap	0.7 ~ 0.8 mm	----
Cylinder head		
Volume	22.74 ~ 23.34 cm ³	----
Max. warpage	----	0.1 mm

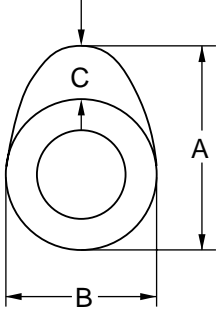
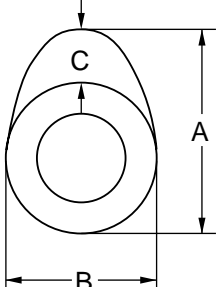
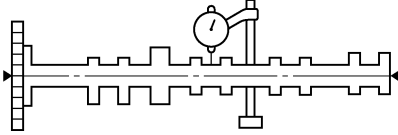

Item	Standard	Limit
Camshafts		
Drive system	Chain drive (right)	----
Camshaft cap inside diameter	24.500 ~ 24.521 mm	----
Camshaft journal diameter	24.472 ~ 24.459 mm	----
Camshaft-journal-to-camshaft-cap clearance	0.028 ~ 0.062 mm	----
Intake camshaft lobe dimensions		
		
Measurement A	33.05 ~ 33.15 mm	32.05 mm
Measurement B	24.997 ~ 25.097 mm	23.997 mm
Exhaust camshaft lobe dimensions		
		
Measurement A	33.05 ~ 33.15 mm	32.95 mm
Measurement B	24.997 ~ 25.097 mm	24.897 mm
Max. camshaft runout	----	0.03 mm
		

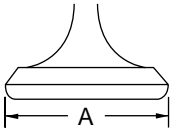
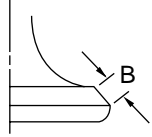
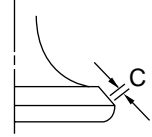
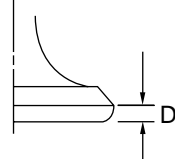
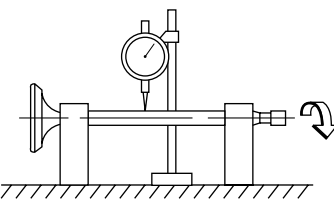

Item	Standard	Limit	
Timing chain			
Model/number of links	RH2015/136	----	
Tensioning system	Automatic	----	
Valves, valve seats, valve guides			
Valve clearance (cold)			
Intake	0.15 ~ 0.22 mm	----	
Exhaust	0.18 ~ 0.25 mm	----	
Valve dimensions			
			
Head Diameter	Face Width	Seat Width	Margin Thickness
Valve head diameter A			
Intake	29.9 ~ 30.1 mm		----
Exhaust	25.9 ~ 26.1 mm		----
Valve face width B			
Intake	1.2 ~ 2.0 mm		----
Exhaust	1.2 ~ 2.0 mm		----
Valve seat width C			
Intake	0.9 ~ 1.1 mm		1.6 mm
Exhaust	0.9 ~ 1.1 mm		1.6 mm
Valve margin thickness D			
Intake	0.8 ~ 1.2 mm		----
Exhaust	0.5 ~ 0.9 mm		----
Valve stem diameter			
Intake	4.975 ~ 4.990 mm		4.945 mm
Exhaust	4.960 ~ 4.975 mm		4.930 mm
Valve guide inside diameter			
Intake	5.000 ~ 5.012 mm		5.05 mm
Exhaust	5.000 ~ 5.012 mm		5.05 mm
Valve-stem-to-valve-guide clearance			
Intake	0.010 ~ 0.037 mm		0.08 mm
Exhaust	0.025 ~ 0.052 mm		0.1 mm
Valve stem runout	----		0.01 mm
			
Valve seat width			
Intake	0.9 ~ 1.1 mm		1.6 mm
Exhaust	0.9 ~ 1.1 mm		1.6 mm

ENGINE SPECIFICATIONS

SPEC

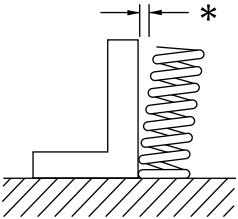
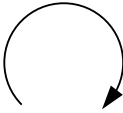

Item	Standard	Limit
Valve springs		
Free length		
Intake	39.7 mm	37.7 mm
Exhaust	39.7 mm	37.7 mm
Installed length (valve closed)		
Intake	33 mm	----
Exhaust	33 mm	----
Compressed spring force (installed)		
Intake	136 ~ 158 N (13.9 ~ 16.1 kgf)	----
Exhaust	136 ~ 158 N (13.9 ~ 16.1 kgf)	----
Spring tilt		
		
Intake	----	2.5° /1.7 mm
Exhaust	----	2.5° /1.7 mm
Winding direction (top view)		
Intake	Clockwise	----
Exhaust	Clockwise	----
		



Item	Standard	Limit
Cylinders		
Cylinder arrangement	Forward inclined parallel 4-cylinder	----
Bore × stroke	79.0 × 66.2 mm	----
Compression ratio	10.8 : 1	----
Bore	79.00 ~ 79.01 mm	----
Max. taper	----	0.05 mm
Max. out-of-round	----	0.05 mm
Pistons		
Piston-to-cylinder clearance	0.020 ~ 0.045 mm	0.012 mm
Diameter D	78.965 ~ 78.980 mm	----
Height H	5 mm	----
Piston pin bore (in the piston)		
Diameter	19.004 ~ 19.015 mm	19.045 mm
Offset	0.5 mm	----
Offset direction	Intake side	----
Piston pins		
Outside diameter	18.991 ~ 19.000 mm	18.971 mm
Piston-pin-to-piston-pin-bore clearance	0.004 ~ 0.024 mm	0.074 mm
Piston rings		
Top ring		
Ring type	Barrel	----
Dimensions (B × T)	1.0 × 2.8 mm	----
End gap (installed)	0.35 ~ 0.45 mm	0.7 mm
Ring side clearance	0.03 ~ 0.07 mm	0.12 mm
2nd ring		
Ring type	Taper	----
Dimensions (B × T)	1.0 × 2.9 mm	----
End gap (installed)	0.75 ~ 0.85 mm	1.2 mm
Ring side clearance	0.02 ~ 0.06 mm	0.12 mm

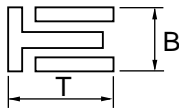
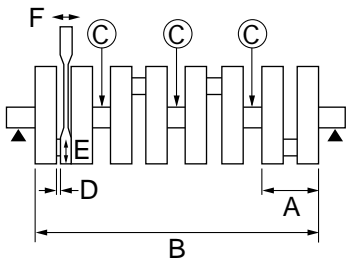

Item	Standard	Limit
<p>Oil ring</p>  <p>Dimensions (B × T)</p> <p>End gap (installed)</p> <p>Ring side clearance</p>	<p>2.0 × 2.5 mm</p> <p>0.2 ~ 0.6 mm</p> <p>0.06 ~ 0.15 mm</p>	<p>----</p> <p>----</p> <p>----</p>
<p>Connecting rods</p> <p>Crankshaft-pin-to-big-end-bearing clearance</p> <p>Bearing color code</p> <p>Small end inside diameter</p>	<p>0.031 ~ 0.048 mm</p> <p>1 = Blue 2 = Black 3 = Brown 4 = Green 5 = Yellow 6 = Pink</p> <p>19.005 ~ 19.018 mm</p>	<p>----</p> <p>----</p> <p>----</p>
<p>Crankshaft</p>  <p>Width A</p> <p>Width B</p> <p>Max. runout C</p> <p>Big end side clearance D</p> <p>Big end radial clearance</p> <p>Crankshaft-journal-to-crankshaft-journal-bearing clearance</p> <p>Bearing color code</p> <p>Position of thrust bearing</p>	<p>61.6 ~ 63.2 mm</p> <p>325.1 ~ 326.3 mm</p> <p>----</p> <p>0.160 ~ 0.262 mm</p> <p>0.031 ~ 0.048 mm</p> <p>0.027 ~ 0.045 mm</p> <p>2 = Black 3 = Brown 4 = Green 5 = Yellow 6 = Pink 7 = Red 8 = White</p> <p>#3 JOURNAL</p>	<p>----</p> <p>----</p> <p>0.03 mm</p> <p>----</p> <p>----</p> <p>----</p> <p>----</p> <p>----</p>
<p>Balancer</p> <p>Balancer drive method</p>	<p>Gear</p>	<p>----</p>
<p>Clutch</p> <p>Clutch type</p> <p>Clutch release method</p> <p>Operation</p> <p>Clutch cable free play (at the end of the clutch lever)</p> <p>Friction plates</p> <p>Thickness</p> <p>Plate quantity</p>	<p>Wet, multiple disc</p> <p>Hydraulic inner push</p> <p>Left-hand operation</p> <p>1.9 ~ 20.7 mm</p> <p>2.9 ~ 3.1 mm</p> <p>9</p>	<p>----</p> <p>----</p> <p>----</p> <p>----</p> <p>2.8 mm</p> <p>----</p>

ENGINE SPECIFICATIONS

SPEC



Item	Standard	Limit
Clutch plates		
Thickness	1.9 ~ 2.1 mm	----
Plate quantity	8	----
Max. warpage	----	0.1 mm
Clutch spring		
Free length	6.78 mm	----
Spring quantity	1	----
Min. length	----	6.44 mm
Push rod bending limit	----	0.2 mm
Transmission		
Transmission type	Constant mesh, 5-speed	----
Primary reduction system	Helical gear	----
Primary reduction ratio	75/48 (1.563)	----
Secondary reduction system	Shaft drive	----
Secondary reduction ratio	35/36 × 21/27 × 33/9 (2.773)	----
Operation	Left-foot operation	----
Gear ratios		
1st gear	43/17 (2.529)	----
2nd gear	39/22 (1.773)	----
3rd gear	31/23 (1.348)	----
4th gear	28/26 (1.077)	----
5th gear	26/28 (0.929)	----
Max. main axle runout	----	0.08 mm
Max. drive axle runout	----	0.08 mm
Shifting mechanism		
Shift mechanism type	Shift drum and guide bar	----
Max. shift fork guide bar bending	----	0.1 mm
Installed shift rod length	209 mm	----
Air filter type	Dry element	----
Fuel pump		
Pump type	Electrical	----
Model (manufacturer)	5JW1 (DENSO)	----
Consumption amperage <max>	5.5 A	----
Output pressure	294 kPa (2.94 kg/cm ² , 2.94 bar)	----

ENGINE SPECIFICATIONS

SPEC



Item	Standard	Limit
Throttle bodies		
Model (manufacturer) × quantity	42EHS (MIKUNI) × 4	----
Intake vacuum pressure	33.3 kPa (250 mmHg)	----
Throttle cable free play (at the flange of the throttle grip)	3 ~ 5 mm	----
ID mark	5JW1	----
Shaft drive		
Final gear backlash	0.1 ~ 0.2 mm	----



CHASSIS SPECIFICATIONS

Item	Standard	Limit
Frame		
Frame type	Diamond	----
Caster angle	26°	----
Trail	109 mm	----
Front wheel		
Wheel type	Cast wheel	----
Rim		
Size	17 × MT3.50	----
Material	Aluminum	----
Wheel travel	135 mm	----
Wheel runout		
Max. radial wheel runout	----	1 mm
Max. lateral wheel runout	----	0.5 mm
Rear wheel		
Wheel type	Cast wheel	----
Rim		
Size	17 × MT5.50	----
Material	Aluminum	----
Wheel travel	125 mm	----
Wheel runout		
Max. radial wheel runout	----	1 mm
Max. lateral wheel runout	----	0.5 mm
Front tire		
Tire type	Tubeless	----
Size	120/70ZR 17 (58W)	----
Model (manufacturer)	MEZ4B FRONT (METZELER)/ BT020F N (BRIDGESTONE)	----
Tire pressure (cold)		
0 ~ 90 kg	250 kPa (2.5 kgf/cm ² , 2.5 bar)	----
90 ~ 208 kg	250 kPa (2.5 kgf/cm ² , 2.5 bar)	----
High-speed riding	250 kPa (2.5 kgf/cm ² , 2.5 bar)	----
Min. tire tread depth	----	1.6 mm

CHASSIS SPECIFICATIONS

SPEC

Item	Standard	Limit
Rear tire		
Tire type	Tubeless	----
Size	180/55ZR 17 (73W)	----
Model (manufacturer)	MEZ4J (METZELER)/ BT020R N (BRIDGESTONE)	----
Tire pressure (cold)		
0 ~ 90 kg	250 kPa (2.5 kgf/cm ² , 2.5 bar)	----
90 ~ 208 kg	290 kPa (2.9 kgf/cm ² , 2.9 bar)	----
High-speed riding	290 kPa (2.9 kgf/cm ² , 2.9 bar)	----
Min. tire tread depth	----	1.6 mm
Front brakes		
Brake type	Dual-disc brake	----
Operation	Right-hand operation	----
Brake lever free play (at lever end)	2.2 ~ 11.2 mm	----
Recommended fluid	DOT 4	----
Brake discs		
Diameter × thickness	298 × 5 mm	----
Min. thickness	----	4.5 mm
Max. deflection	----	0.1 mm
Brake pad lining thickness	5.5 mm	0.5 mm
Master cylinder inside diameter	14 mm	----
Caliper cylinder inside diameter	30.2 mm and 27 mm	----
Rear brake		
Brake type	Single-disc brake	----
Operation	Right-foot operation	----
Brake pedal position (below the top of the rider footrest)	42 mm	----
Brake pedal free play	4.7 ~ 9.9 mm	----
Recommended fluid	DOT 4	----
Brake discs		
Diameter × thickness	282 × 6 mm	----
Min. thickness	----	5.5 mm
Max. deflection	----	0.15 mm
Brake pad lining thickness	5.8 mm	0.8 mm
Master cylinder inside diameter	14 mm	----
Caliper cylinder inside diameter	41.3 mm	----
Clutch		
Recommended fluid	DOT 4	----
Master cylinder inside diameter	14 mm	----
Release cylinder inside diameter	33.6 mm	----

CHASSIS SPECIFICATIONS

SPEC

Item	Standard	Limit
Front suspension		
Suspension type	Telescopic fork	----
Front fork type	Coil spring/oil damper	----
Front fork travel	135 mm	----
Spring		
Free length	270 mm	264.6 mm
Spacer length	143.5 mm	----
Installed length	258 mm	----
Spring rate (K1)	7.35 N/mm (0.735 kgf/mm)	----
Spring stroke (K1)	0 ~ 135 mm (0 ~ 13.5 kgf/mm)	----
Optional spring available	No	----
Fork oil	Yamaha fork oil 10 WT	----
Recommended oil	Suspension oil "01" or equivalent	----
Quantity (each front fork leg)	700 cm ³	----
Level (from the top of the inner tube, with the inner tube fully compressed, and without the fork spring)	79 mm	----
Inner tube outer diameter	48 mm	----
Inner tube bearing	----	0.2 mm
Damper adjusting rod locknut distance	12 mm	----
Spring preload adjusting positions		
Minimum	6	----
Standard	3	----
Maximum	1	----
Rebound damping adjusting positions		
Minimum*	17	----
Standard*	12	----
Maximum*	1	----
Compression damping adjusting positions		
Minimum*	21	----
Standard*	12	----
Maximum	1	----
*from the fully turned-in position		
Steering		
Steering bearing type	Angular	----
Lock to lock angle (left)	34°	----
Lock to lock angle (right)	34°	----

CHASSIS SPECIFICATIONS

SPEC



Item	Standard	Limit
Rear suspension		
Suspension type	Swingarm (link suspension)	----
Rear shock absorber assembly type	Coil spring/gas-oil damper	----
Rear shock absorber assembly travel	60 mm	----
Upper spring		
Free length	159 mm	155.82 mm
Installed length	138.1 mm	----
Lower spring		
Free length	74 mm	72.52 mm
Installed length	65.4 mm	----
Spring rate (K1)	71.6 N/mm (7.16 kgf/mm)	----
Spring stroke (K1)	0 ~ 31.3 mm	----
Spring rate (K2)	102 N/mm (10.2 kgf/mm)	----
Spring stroke (K2)	31.3 ~ 60.0 mm	----
Optional spring available	No	----
Standard spring preload gas/air pressure	1,200 kPa (12.0 kg/cm ² , 12.0 bar)	----
Spring preload adjusting positions		
Rider only	SOFT	----
With passenger or cargo	HARD	----
Rebound damping adjusting positions		
Minimum*	20	----
Standard*	10	----
Maximum*	3	----
*from the fully turned-in position		
Swingarm		
Free play (at the end of the swingarm)		
Radial	----	0 mm
Axial	----	0 mm



ELECTRICAL SPECIFICATIONS

Item	Standard	Limit
System voltage	12 V	----
Ignition system		
Ignition system type	Transistorized coil ignition (digital)	----
Ignition timing	5° BTDC at 1,050 r/min	----
Advancer type	Electric	----
Pickup coil resistance/color	420.8 ~ 569.3 Ω/Gy-B	----
Transistorized coil ignition unit model (manufacturer)	F8T911 (MITSUBISHI)	----
Ignition coils		
Model (manufacturer)	J0313 (DENSO)	----
Minimum ignition spark gap	6 mm	----
Primary coil resistance	1.87 ~ 2.53 Ω	----
Secondary coil resistance	12 ~ 18 kΩ	----
Spark plug caps		
Material	Resin	----
Resistance	10 kΩ	----
Charging system		
System type	AC magneto	----
Model (manufacturer)	TLNZ79 (DENSO)	----
Nominal output	14 V/490 W at 5,000 r/min	----
Stator coil resistance/color	0.15 ~ 0.23 Ω/W-W	----
Voltage regulator		
Regulator type	Semiconductor, short circuit	----
Model (manufacturer)	FH001 (SHINDENGEN)	----
No-load regulated voltage	14.1 ~ 14.9 V	----
Rectifier		
Model (manufacturer)	FH001 (SHINDENGEN)	----
Rectifier capacity	35 A	----
Withstand voltage	200 V	----
Battery		
Battery type (manufacturer)	GT14B-4 (GS)	----
Battery voltage/capacity	12 V/12 AH	----
Specific gravity	1.320	----
Ten hour rate amperage	1.2 A	----
Headlight type	Halogen bulb	----
Indicator light (voltage/wattage × quantity)		
Neutral indicator light	14 V 1.12 W × 1	----
Turn signal indicator light	14 V 1.4 W × 2	----
Oil level warning light	14 V 1.12 W × 1	----
High beam indicator light	14 V 1.12 W × 1	----
Engine trouble warning light	14 V 1.12 W × 1	----

ELECTRICAL SPECIFICATIONS

SPEC

Item	Standard	Limit
Bulbs (voltage/wattage × quantity)		
Headlight	12 V 60 W/55 W × 2	----
Auxiliary light	12 V 5 W × 2	----
Tail/brake light	12 V 5 W/21 W × 2	----
Turn signal light	12 V 21 W × 4	----
Meter light	14 V 1.12 W × 1	----
Electric starting system		
System type	Constant mesh	----
Starter motor		
Model (manufacturer)	5JW (YAMAHA)	----
Power output	0.8 kW	----
Brushes		
Overall length	10.8 mm	3.65 mm
Spring force	5.28 ~ 7.92 N (528 ~792 g)	----
Commutator resistance	0.024 ~ 0.030 Ω	----
Commutator diameter	24.5 mm	23.5 mm
Mica undercut	1.5 mm	----
Starter relay		
Model (manufacturer)	2768079-A (JIDECO)	----
Amperage	180 A	----
Coil resistance	4.18 ~ 4.62 Ω	----
Horn		
Horn type	Plane	----
Model (manufacturer) × quantity	YF-12 (NIKKO) × 2	----
Max. amperage	3 A	----
Performance	105 ~ 113 db/2 m	----
Coil resistance	1.15 ~ 1.25 Ω	----
Turn signal relay		
Relay type	Full-transistor	----
Model (manufacturer)	FE246BH (DENSO)	----
Self-cancelling device built-in	No	----
Turn signal blinking frequency	75 ~ 95 cycles/min.	----
Wattage	21 W × 2 + 3.4 W	----
Oil level switch model (manufacturer)	5JW (DENSO)	----
Fuel sender		
Model (manufacturer)	5JW (DENSO)	----
Resistance	20 ~ 140 Ω at 25 °C	----
Sidestand relay		
Model (manufacturer)	G8R-30Y-N (OMRON)	----
Coil resistance	180 Ω	----
Headlight relay 2		
Model	ACM33211 M05	----

ELECTRICAL SPECIFICATIONS

SPEC

Item	Standard	Limit
Fuel pump maximum amperage	5.5 A	----
Fuel injection system relay model (manufacturer)	ACM33211 M05	----
Radiator fan		
Model	5JW	----
Running rpm	3,300 r/min	----
Fan motor relay		
Model	ACM33211 M05	----
Atmospheric pressure sensor		
Thermostat type (manufacturer)	4FM (NIPPON THERMOSTAT)	----
Valve opening temperature	69 ~ 73 °C	----
Valve full open temperature	85 °C	----
Valve lift – full open	8 mm	----
Intake air temperature sensor		
Model (manufacturer)	25978 (MITSUBISHI)	----
Resistance	5.4 ~ 6.6 Ω at 80 °C	----
Coolant temperature sender		
Model (manufacturer)	8CC (MITSUBISHI)	----
Resistance	5.21 ~ 6.37 kΩ at 0 °C 0.290 ~ 0.354 kΩ at 80 °C	----
Fuses (amperage × quantity)		
Main fuse	50 A × 1	----
Fuel injection system fuse	15 A	----
Headlight fuse	25 A × 1	----
Signaling system fuse	15 A × 1	----
Ignition fuse	10 A × 1	----
Radiator fan motor fuse	15 A × 1	----
Hazard lighting fuse	7.5 A	----
Parking lighting fuse	10 A	----
Backup fuse (odometer and clock)	10 A	----
Windshield motor fuse	2 A	----
Reserve fuse	25 A, 15 A, 10 A, 7.5 A, 2 A × 1	----

CONVERSION TABLE/ GENERAL TIGHTENING TORQUE SPECIFICATIONS



EB201000

CONVERSION TABLE

All specification data in this manual are listed in SI and METRIC UNITS.

Use this table to convert METRIC unit data to IMPERIAL unit data.

Ex.

METRIC	MULTIPLIER	IMPERIAL
** mm	0.03937	** in
2 mm	0.03937	0.08 in

CONVERSION TABLE

METRIC TO IMPERIAL			
	Metric unit	Multiplier	Imperial unit
Tightening torque	m·kg	7.233	ft·lb
	m·kg	86.794	in·lb
	cm·kg	0.0723	ft·lb
	cm·kg	0.8679	in·lb
Weight	kg	2.205	lb
	g	0.03527	oz
Speed	km/hr	0.6214	mph
Distance	km	0.6214	mi
	m	3.281	ft
	m	1.094	yd
	cm	0.3937	in
	mm	0.03937	in
Volume/ Capacity	cc (cm ³)	0.03527	oz (IMP liq.)
	cc (cm ³)	0.06102	cu-in
	lt (liter)	0.8799	qt (IMP liq.)
	lt (liter)	0.2199	gal (IMP liq.)
Misc.	kg/mm	55.997	lb/in
	kg/cm ²	14.2234	psi (lb/in ²)
	Centigrade (°C)	9/5+32	Fahrenheit (°F)

EAS00030

GENERAL TIGHTENING TORQUE SPECIFICATIONS

This chart specifies tightening torques for standard fasteners with a standard ISO thread pitch. Tightening torque specifications for special components or assemblies are provided for each chapter of this manual. To avoid warpage, tighten multi-fastener assemblies in a crisscross pattern and progressive stages until the specified tightening torque is reached. Unless otherwise specified, tightening torque specifications require clean, dry threads. Components should be at room temperature.

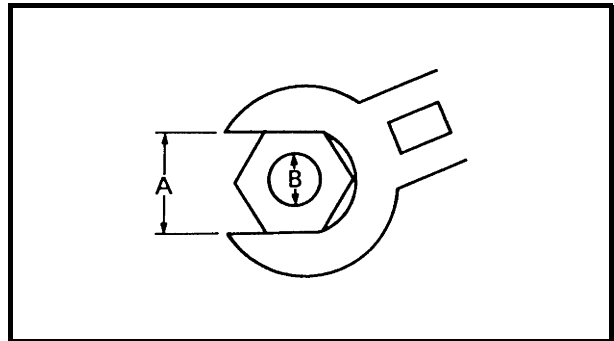

A: Width across flats

B: Thread diameter

A (nut)	B (bolt)	General tightening torques		
		Nm	m·kg	ft·lb
10 mm	6 mm	6	0.6	4.3
12 mm	8 mm	15	1.5	11
14 mm	10 mm	30	3.0	22
17 mm	12 mm	55	5.5	40
19 mm	14 mm	85	8.5	61
22 mm	16 mm	130	13.0	94

TIGHTENING TORQUES



TIGHTENING TORQUES ENGINE TIGHTENING TORQUES

Part to be tightened	Part name	Thread size	Q'ty	Tightening torque		Remarks
				Nm	m·kgf	
Spark plug	—	M10	4	13	1.3	
Camshaft sensor	Bolt	M6	1	10	1.0	
Cylinder head cover	Bolt	M6	8	10	1.0	
Camshaft cap	Bolt	M6	20	10	1.0	
Camshaft sprocket	Bolt	M7	4	24	2.4	
Timing chain tensioner	Bolt	M6	2	10	1.0	
Timing chain tensioner cap	Bolt	M6	1	10	1.0	
Cylinder head	Bolt	M10	10	See NOTE. *1		
Cylinder head	Bolt	M6	2	12	1.2	
Cylinder head	Stud bolt	M8	8	15	1.5	
Oil gallery bolt	—	M8	1	20	2.0	
Generator cover	Bolt	M6	8	12	1.2	
Generator rotor	Bolt	M12	1	130	13.0	
Starter clutch	Bolt	M8	3	32	3.2	
Stator assembly	Screw	M6	3	10	1.0	
Stator assembly lead holder	Screw	M6	1	6	0.6	
Pickup coil rotor cover	Bolt	M6	8	12	1.2	
Ignition timing check bolt	—	M8	1	15	1.5	
Crankshaft position sensor	Bolt	M5	2	4	0.4	
Pickup coil rotor	Bolt	M10	1	45	4.5	
Clutch cover	Bolt	M6	10	12	1.2	
Damper cover	Screw	M6	4	12	1.2	
Oil guide plate	Bolt	M6	2	10	1.0	
Clutch spring plate retainer	Bolt	M6	6	8	0.8	
Clutch boss	Nut	M20	1	90	9.0	Use a lock washer.
Shift arm pinch bolt	—	M6	1	10	1.0	
Shift rod	Nut	M6	1	7	0.7	
Shift rod	Nut	M6	1	7	0.7	Left-hand threads
Shift rod joint	Bolt	M6	1	10	1.0	
Shift pedal	Bolt	M8	1	30	3.0	
Oil baffle plate	Bolt	M6	3	10	1.0	
Shift shaft spring stopper	Bolt	M8	1	22	2.2	
Engine oil drain bolt	—	M14	1	43	4.3	
Oil filter cartridge	—	M20	1	17	1.7	
Oil filter bolt	—	M20	1	70	7.0	
Oil level switch	Bolt	M6	2	10	1.0	
Oil pan	Bolt	N6	20	12	1.2	
Oil delivery pipe	Bolt	M6	1	10	1.0	

TIGHTENING TORQUES

SPEC



Part to be tightened	Part name	Thread size	Q'ty	Tightening torque		Remarks
				Nm	m·kgf	
Oil pipe	Bolt	M6	2	10	1.0	
Oil strainer	Bolt	M6	2	10	1.0	
Oil pump assembly	Bolt	M6	3	12	1.2	
Oil pump housing cover	Bolt	M6	3	12	1.2	
Left middle gear cover	Bolt	M6	9	12	1.2	
Right middle gear cover	Bolt	M6	3	12	1.2	
Middle driven shaft assembly	Bolt	M8	3	25	2.5	
Middle driven pinion gear	Nut	M28	1	110	11.0	Stake
Bearing retainer (middle driven shaft)	—	M68	1	110	11.0	Stake
Middle drive pinion gear	Nut	M22	1	110	11.0	Use a lock washer.
Bearing retainer (middle drive shaft)	—	M88	1	110	11.0	Stake
Oil pump drive chain guide	Bolt	M6	2	10	1.0	
Neutral switch	—	M10	1	20	2.0	
Speed sensor	Bolt	M6	1	10	1.0	
Crankcase	Bolt	M9	10	See NOTE.*2		
Crankcase	Bolt	M8	2	24	2.4	
Crankcase	Bolt	M6	2	12	1.2	
Crankcase	Bolt	M6	17	10	1.0	
Rear balancer cover	Bolt	M6	4	12	1.2	
Balancer lever	Bolt	M8	2	14	1.4	
Balancer shaft pinch bolt	—	M6	2	10	1.0	
Plate	Torx screw	M6	2	12	1.2	
Connecting rod	Nut	M8	8	See NOTE.*3		
Shift drum retainer	Bolt	M6	2	10	1.0	
Main axle assembly	Torx screw	M6	3	12	1.2	Stake
Air filter case	Bolt	M6	2	7	0.7	
Air filter case joint clamp screw	—	M4	4	4	0.4	
Intake air temperature sensor	—	M12	1	18	1.8	
Throttle body joint clamp screw	—	M4	8	3	0.3	
Intake air pressure sensor	Bolt	M5	2	5	0.5	
Air cut-off valve assembly	Bolt	M6	1	10	1.0	
Reed valve cover	Bolt	M6	6	14	1.4	
Radiator	Bolt	M6	3	10	1.0	
Conduit	Bolt	M6	1	10	1.0	
Water jacket joint	Bolt	M6	2	10	1.0	
Oil cooler	Bolt	M6	4	12	1.2	
Thermostat assembly inlet pipe	Bolt	M6	2	10	1.0	
Coolant temperature sensor	—	M12	1	18	1.8	

TIGHTENING TORQUES

SPEC



Part to be tightened	Part name	Thread size	Q'ty	Tightening torque		Remarks
				Nm	m·kgf	
Thermostat assembly	Torx screw	M6	1	10	1.0	
Thermostat housing cover	Bolt	M6	2	10	1.0	
Water pump	Bolt	M6	3	12	1.2	
Water pump housing cover	Bolt	M6	1	10	1.0	
Coolant drain bolt	—	M6	1	10	1.0	
Muffler joint	Bolt	M8	2	20	2.0	
Muffler	Bolt	M10	2	25	2.5	
Exhaust pipe	Nut	M8	8	20	2.0	
Exhaust pipe	Bolt	M8	2	17	1.7	
Exhaust check bolt	—	M6	4	10	1.0	
O ₂ sensor	—	M18	1	45	4.5	
Starter motor	Bolt	M6	2	10	1.0	

NOTE:

- *1: Tighten the cylinder head bolts to 25 Nm (2.5 m • kg) in the proper tightening sequence, loosen and retighten the cylinder head bolts to 25 Nm (2.5 m • kg) in the proper tightening sequence, and then tighten the cylinder head bolts further to reach the specified angle 180° in the proper tightening sequence.
- *2: Tighten the crankcase bolts to 20 Nm (2.0 m • kg) in the proper tightening sequence, loosen and retighten the crankcase bolts to 20 Nm (2.0 m • kg) in the proper tightening sequence, and then tighten the crankcase bolts further to reach the specified angle 120° in the proper tightening sequence.
- *3: Tighten the connecting rod nuts to 20 Nm (2.0 m • kg), and then tighten the connecting rod nuts further to reach the specified angle 120°.

Cylinder head tightening sequence:

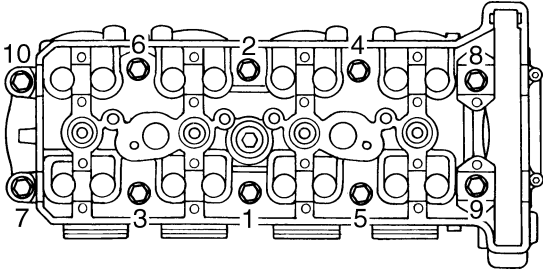

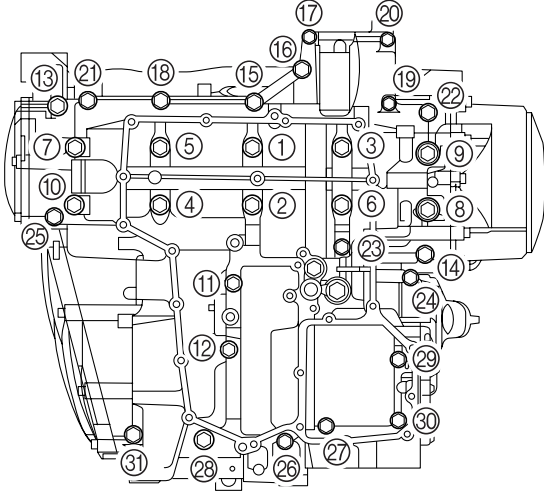

Crankcase tightening sequence:



TIGHTENING TORQUES

SPEC

CHASSIS TIGHTENING TORQUES

Part to be tightened	Thread size	Tightening torque		Remarks
		Nm	m·kgf	
Engine mounting:				
Rear lower mounting bolt	M10	45	4.5	
Spacer bolt	M16	18	1.8	
Rear upper mounting bolt and nut	M10	45	4.5	
Front mounting bolt	M12	55	5.5	
Pinch bolt	M8	24	2.4	
Bolt (engine bracket 1 and frame)	M10	32	3.2	
Bolt (engine bracket 1 and engine)	M8	16	1.6	
Bolt (engine bracket 2 and engine)	M10	36	3.6	
Bolt (engine bracket 2 and frame)	M8	16	1.6	
Front wheel axle	M18	72	7.2	
Front wheel axle pinch bolt	M8	23	2.3	
Brake disc and wheel	M6	18	1.8	
Front brake caliper	M10	40	4.0	
Front brake hose holder and front fork	M6	7	0.7	
Brake caliper bleed screw	M8	6	0.6	
Rear wheel axle nut	M18	125	12.5	
Rear wheel axle pinch bolt	M8	16	1.6	
Brake torque rod	M8	16	1.6	
Rear brake caliper retaining bolt	M10	26	2.6	
Brake hose union bolt	M10	30	3.0	
Front brake master cylinder	M6	10	1.0	
Right rider footrest bracket and frame	M8	28	2.8	
Rear master cylinder and right rider footrest bracket	M8	18	1.8	
Rear brake hose holder and brake torque rod	M6	10	1.0	
Clutch master cylinder	M6	10	1.0	
Clutch hose union bolt	M10	30	3.0	
Clutch release cylinder	M6	10	1.0	
Clutch release cylinder bleed screw	M8	6	0.6	
Front fender	M6	6	0.6	
Upper bracket pinch bolt	M8	30	3.0	
Lower bracket pinch bolt	M8	23	2.3	
Front fork cap bolt and inner tube	M45	25	2.5	
Front fork cap bolt and nut	M10	25	2.5	
Front fork damper rod assembly bolt	M10	35	3.5	
Handlebar and upper bracket	M6	23	2.3	
Grip end	M6	4	0.4	
Steering stem nut	M28	115	11.5	
Lower ring nut (steering stem)	M30	18	1.8	See NOTE.

TIGHTENING TORQUES

SPEC



Part to be tightened	Thread size	Tightening torque		Remarks
		Nm	m·kgf	
Connecting arm and swingarm	M10	48	4.8	
Connecting arm and relay arm	M10	48	4.8	
Rear shock assembly and relay arm	M10	40	4.0	
Rear shock assembly and frame	M12	64	6.4	
Relay arm and frame	M10	40	4.0	
Swingarm pivot shaft and frame	M18	7	0.7	
Swingarm pivot shaft and locknut	M28	115	11.5	
Swingarm pivot shaft and pivot shaft nut	M18	125	12.5	
Locknut retainer	M6	10	1.0	
Final drive housing oil filler bolt	M14	23	2.3	
Final drive housing oil drain bolt	M14	23	2.3	
Final drive assembly and swingarm	M10	42	4.2	
Left rider footrest bracket and frame	M8	28	2.8	
Left rider footrest bracket and engine	M10	49	4.9	
Left rider footrest bracket, sidestand bracket and frame	M10	63	6.3	
Ring gear bearing housing and final drive housing	M10	40	4.0	
Ring gear bearing housing and final drive housing	M8	23	2.3	
Stopper bolt	M10	9	0.9	
Gear coupling and final drive pinion gear	M16	110	11.0	
Final drive pinion gear bearing retainer	M65	110	11.0	
Sidestand and sidestand bracket	M10	58	5.8	
Centerstand bracket and frame	M10	55	5.5	
Centerstand and centerstand bracket	M10	56	5.6	
Rear frame and main frame (upper)	M8	28	2.8	
Rear frame and main frame (lower)	M10	48	4.8	
T-bar and frame	M10	78	7.8	
Fuel pump and fuel tank	M5	4	0.4	
Battery bracket and frame	M6	10	1.0	
Battery holder and battery bracket	M6	10	1.0	
Ignition coil	M6	10	1.0	

NOTE:

1. First, tighten the lower ring nut approximately 52 Nm (5.2 m • kg) by using the torque wrench, then loosen the ring nut completely.
2. Retighten the lower ring nut to specification.

LUBRICATION POINTS AND LUBRICANT TYPES



LUBRICATION POINTS AND LUBRICANT TYPES

ENGINE LUBRICATION POINTS AND LUBRICANT TYPES

Lubrication point	Lubricant
Oil seal lips	
O-rings	
Bearings	
Crankshaft pins	
Piston surfaces	
Piston pins	
Connecting rod bolts and nuts	
Crankshaft journals	
Camshaft lobes	
Camshaft journals	
Balancer weights and shafts	
Valve stems (intake and exhaust)	
Valve stem ends (intake and exhaust)	
Water pump impeller shaft	
Oil pump rotors (inner and outer)	
Oil pump housing	
Oil strainer	
Starter clutch idle gear inner surface	
Starter clutch assembly	
Primary driven gear	
Push rods and ball	
Transmission gears (wheel and pinion)	
Main axle and drive axle	
Shift drum	
Shift forks and shift fork guide bars	
Shift shaft	
Shift pedal bolt	
Damper drive cam and damper driven cam	
Middle driven gear	
Middle drive pinion gear and middle drive shaft	
Middle driven pinion gear and middle driven shaft	

LUBRICATION POINTS AND LUBRICANT TYPES



Lubrication point	Lubricant
Cylinder head cover mating surface	Sealant
Cylinder head cover	Sealant
Crankcase mating surface	Sealant
Clutch cover (crankcase mating surface)	Sealant
Generator cover (crankcase mating surface)	Sealant
Pickup coil rotor cover (crankcase mating surface)	Sealant
Left middle gear cover (crankcase mating surface)	Sealant

LUBRICATION POINTS AND LUBRICANT TYPES



CHASSIS LUBRICATION POINTS AND LUBRICANT TYPES

Lubrication point	Lubricant
Steering bearings and bearing races (upper and lower)	
Front wheel oil seal (right and left)	
Rear wheel oil seal	
Rear wheel drive hub oil seal	
Rear wheel drive hub mating surface	
Rear brake pedal pivot	
Footrest pivoting point	
Centerstand pivoting point and sliding surface	
Sidestand pivoting point and metal-to-metal moving parts	
Throttle grip inner surface	
Brake lever pivot bolt and contact surface	
Clutch lever pivot bolt and contact surface	
Rear shock absorber assembly oil seal	
Rear shock absorber assembly bearing	
Rear shock absorber assembly spacer	
Pivot shaft	
Connecting arm bearing	
Spacer (relay arm and connecting arm)	
Oil seal (relay arm and connecting arm)	

OIL FLOW DIAGRAMS

- ① Crankshaft
- ② Oil pump
- ③ Oil pipe
- ④ Relief valve
- ⑤ Oil filter cartridge
- ⑥ Main axle

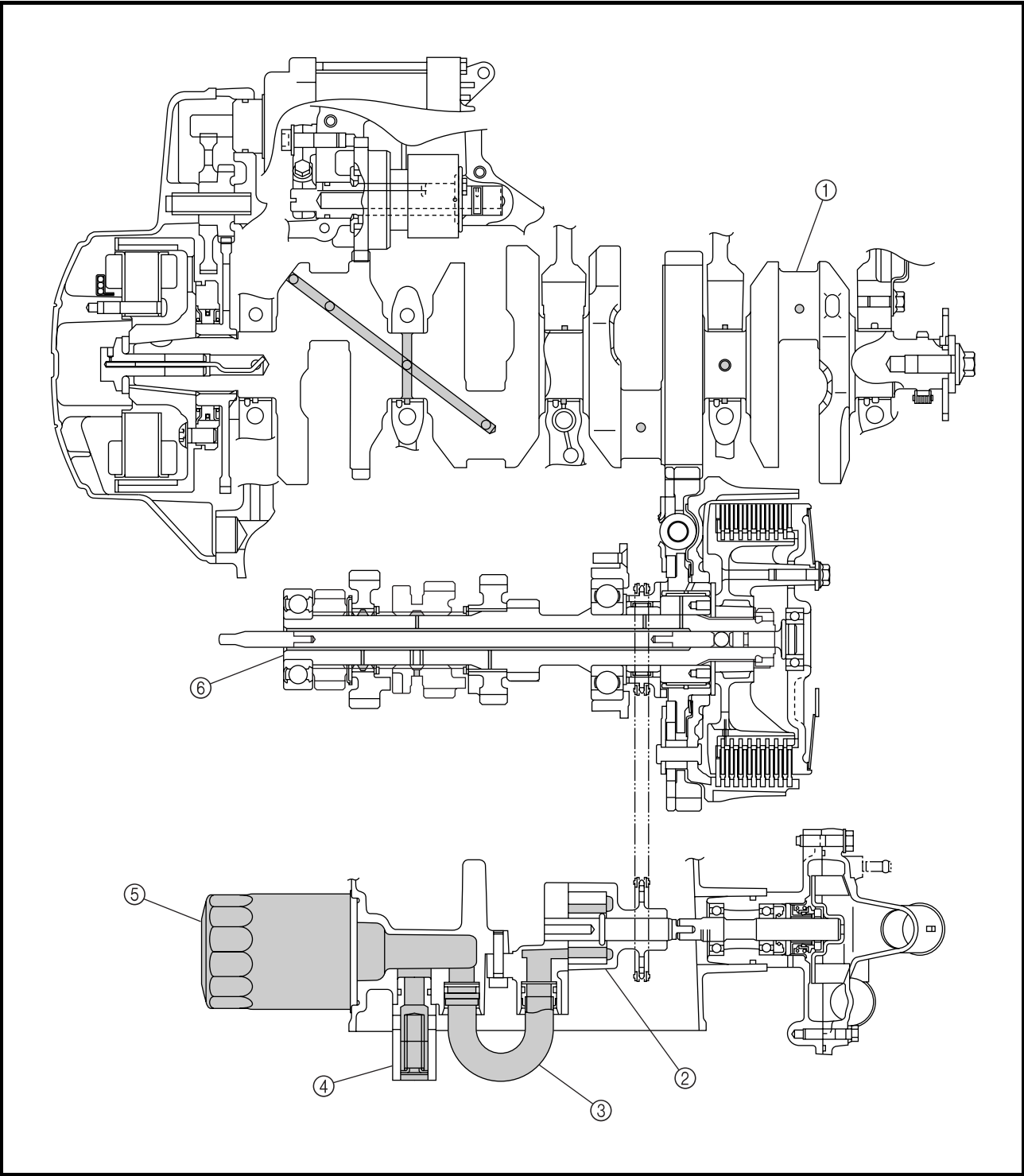

- ① Crankshaft
- ② Main axle
- ③ Drive axle

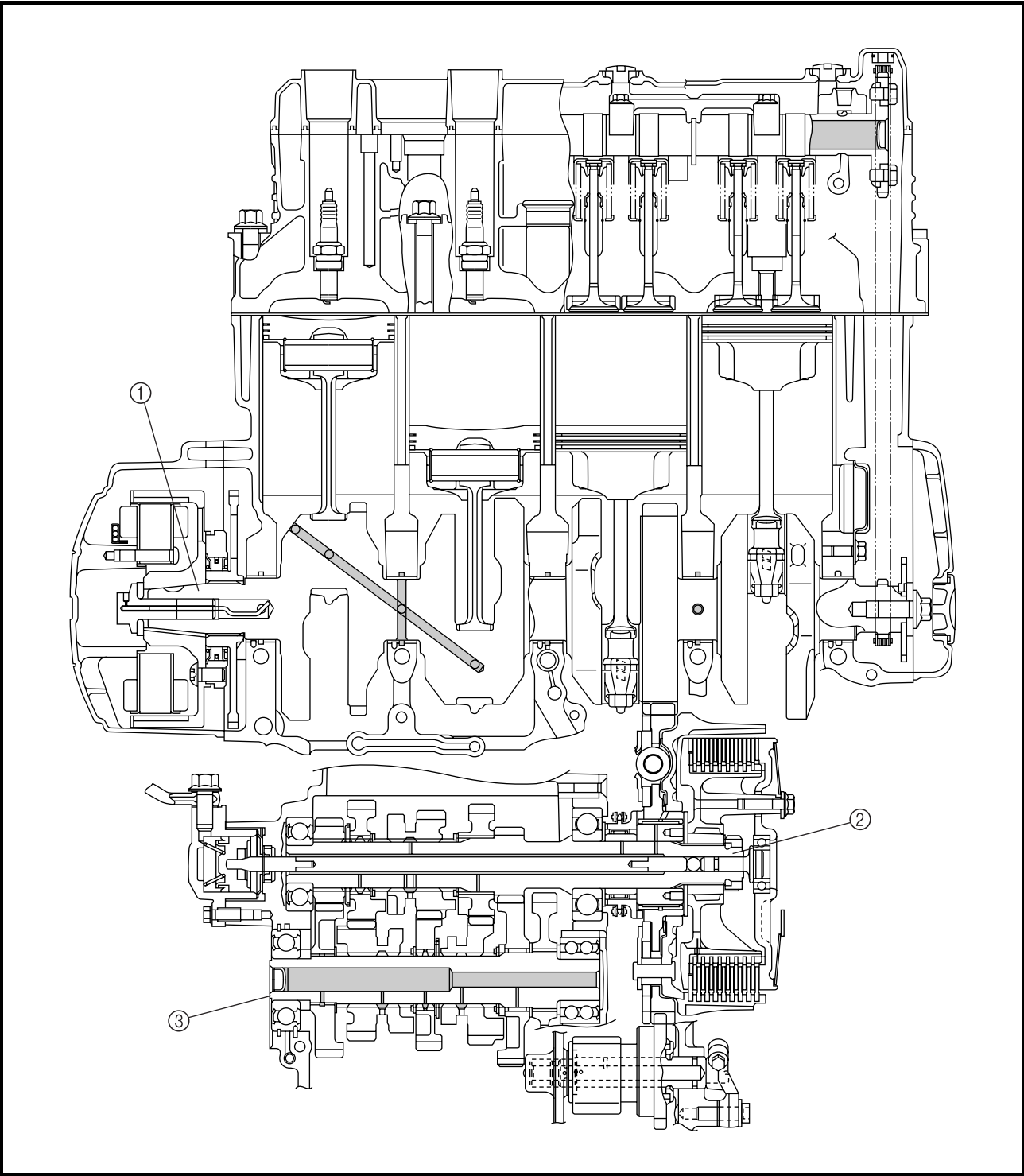

- ① Oil nozzle
- ② Main gallery bolt
- ③ Crankshaft

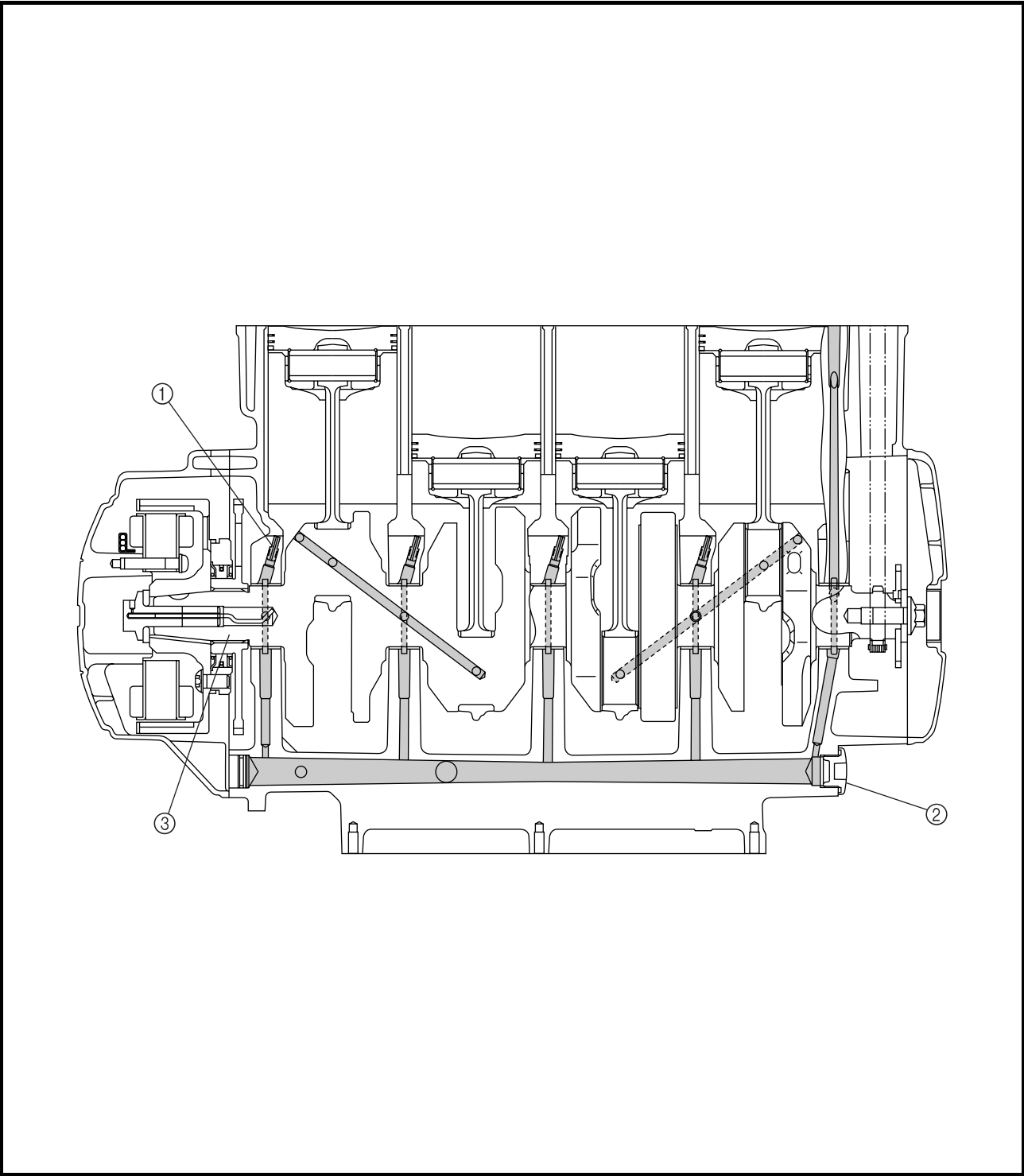

- ① Main axle
- ② Drive axle
- ③ Oil delivery pipe

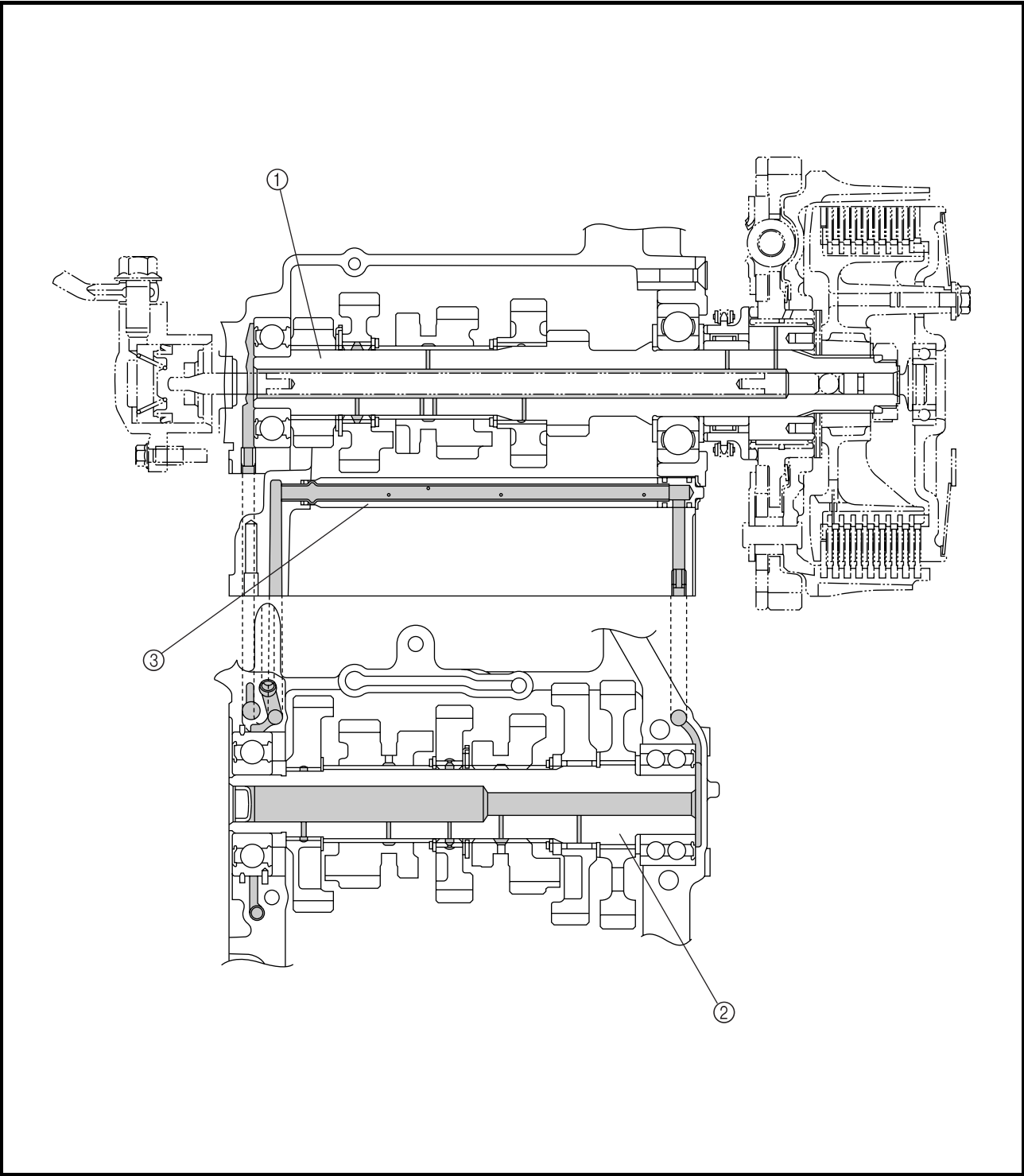

- ① Exhaust camshaft
- ② Oil check bolt
- ③ Intake camshaft

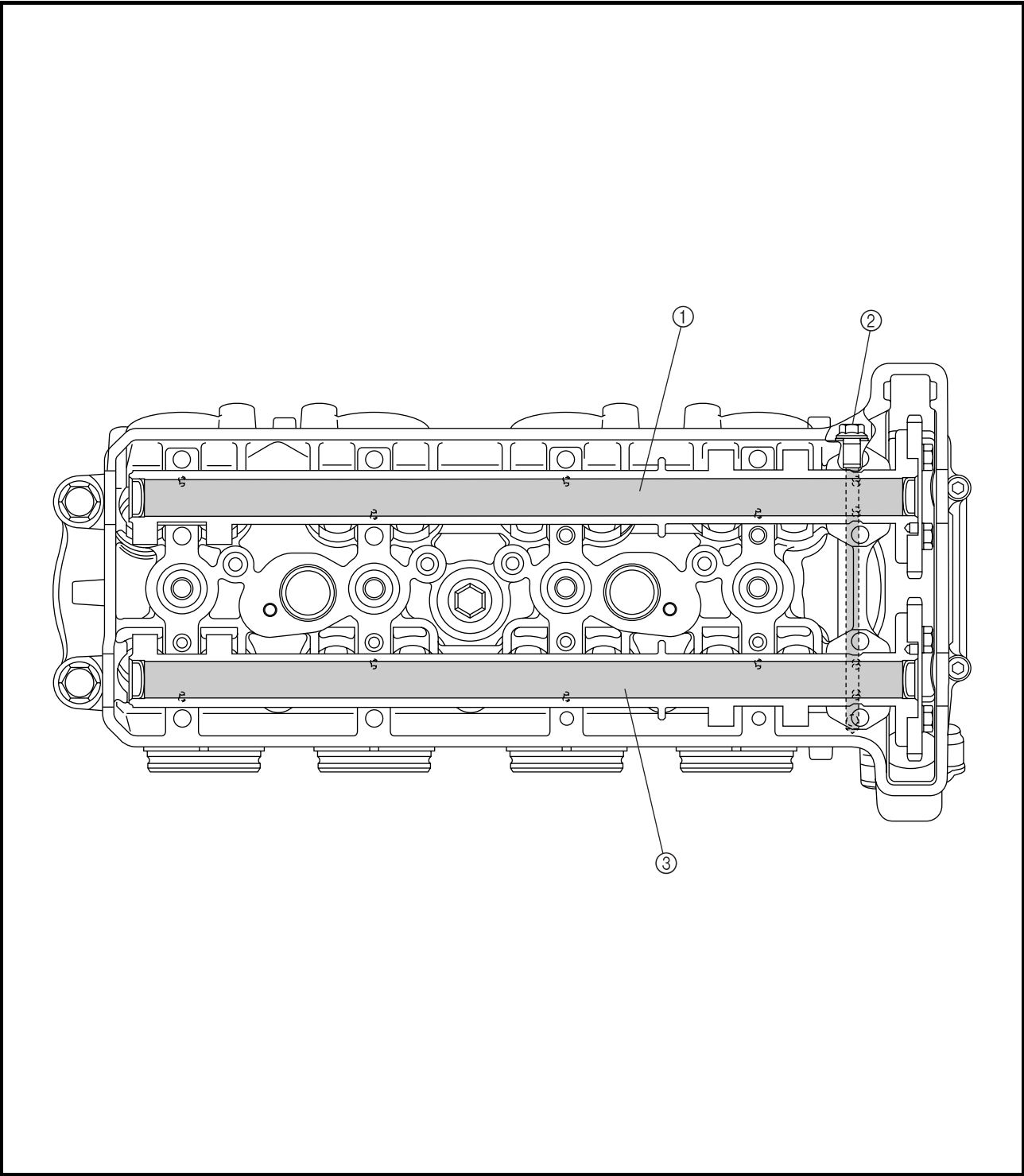

- ① Oil check bolt
- ② Crankshaft
- ③ Oil cooler
- ④ Oil pump
- ⑤ Oil strainer
- ⑥ Oil pipe

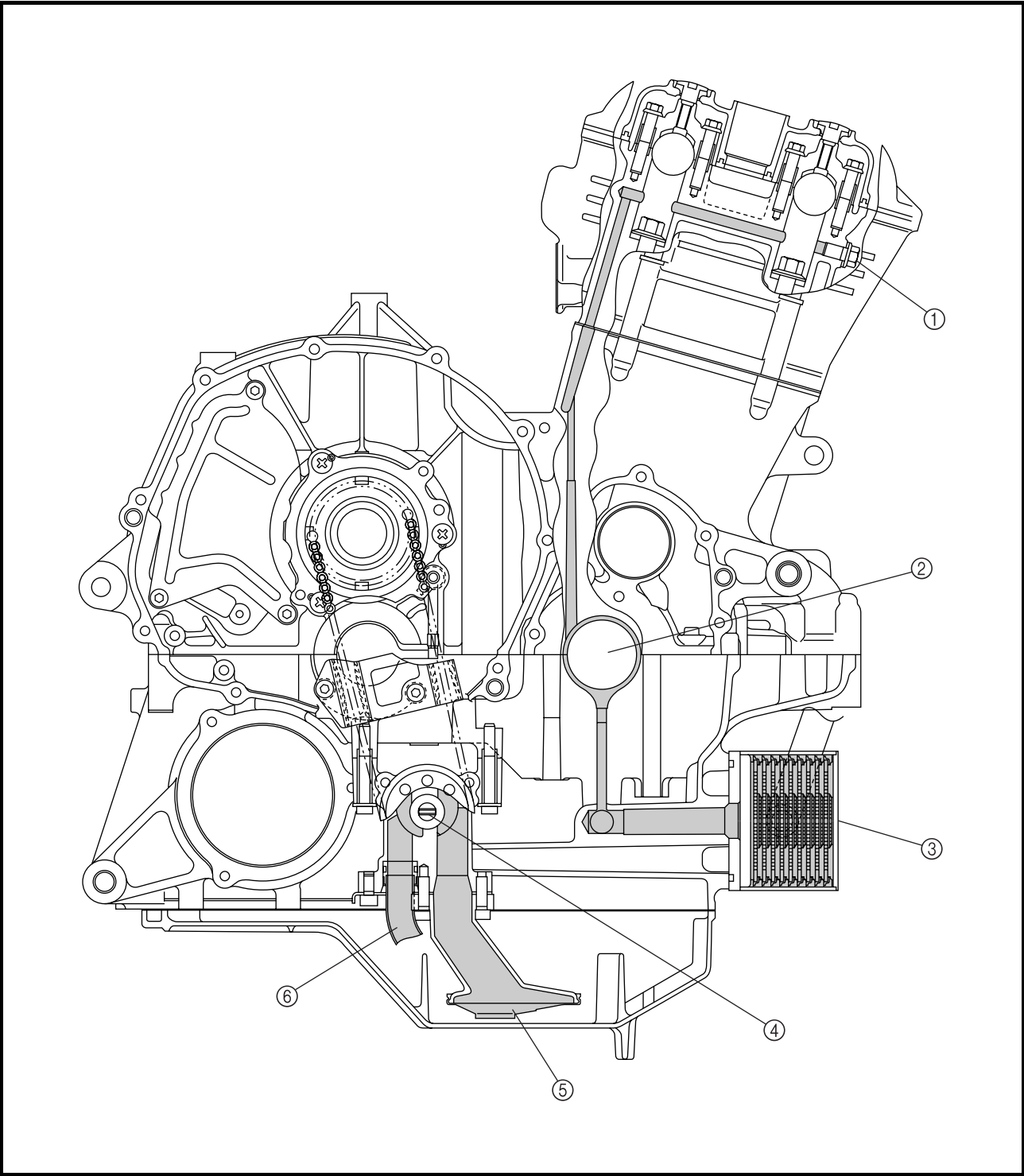

- ① Crank pin
- ② Crankshaft

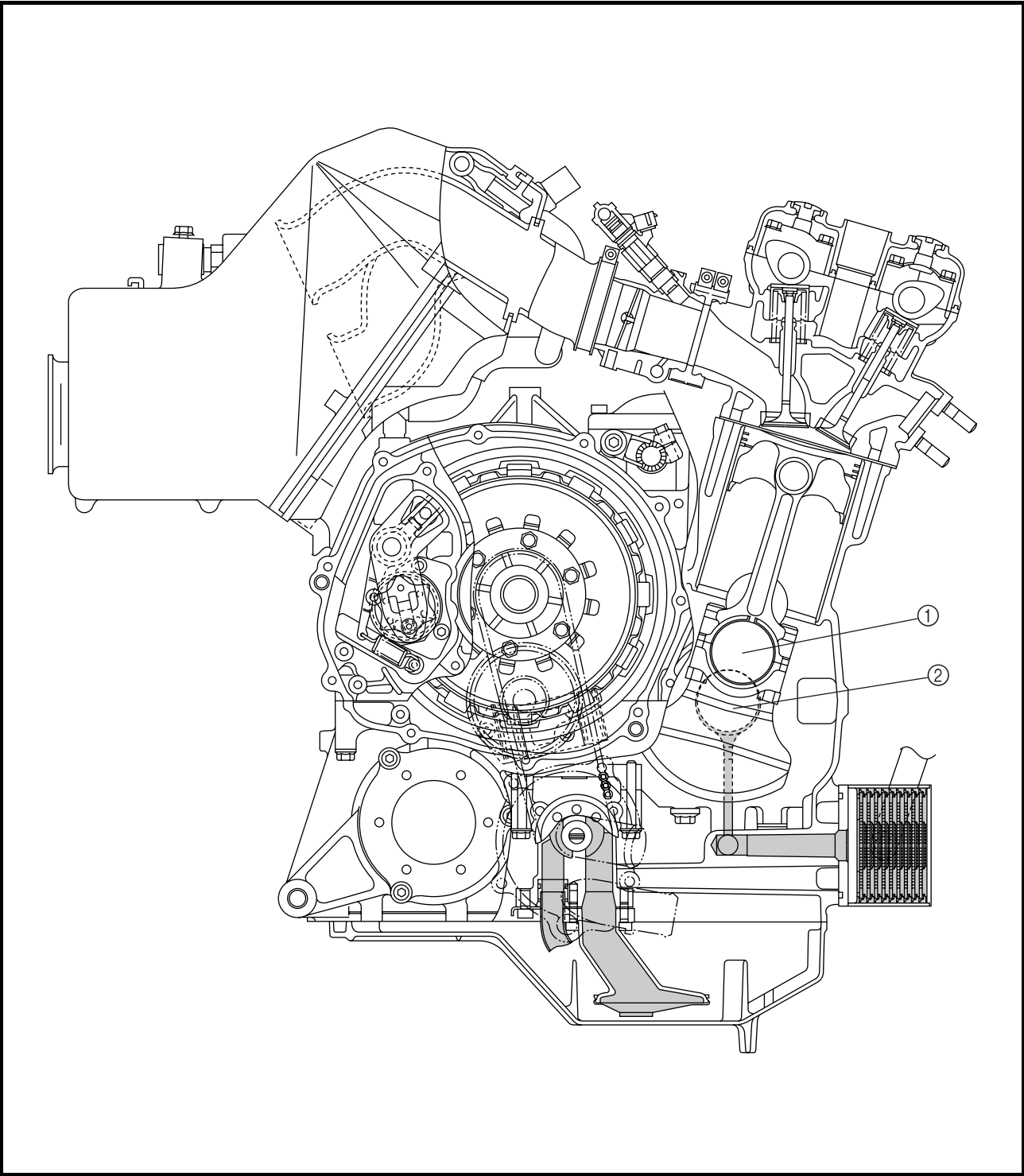

- ① Rear balancer
- ② Oil delivery pipe
- ③ Crankshaft
- ④ Front balancer
- ⑤ Crank pin

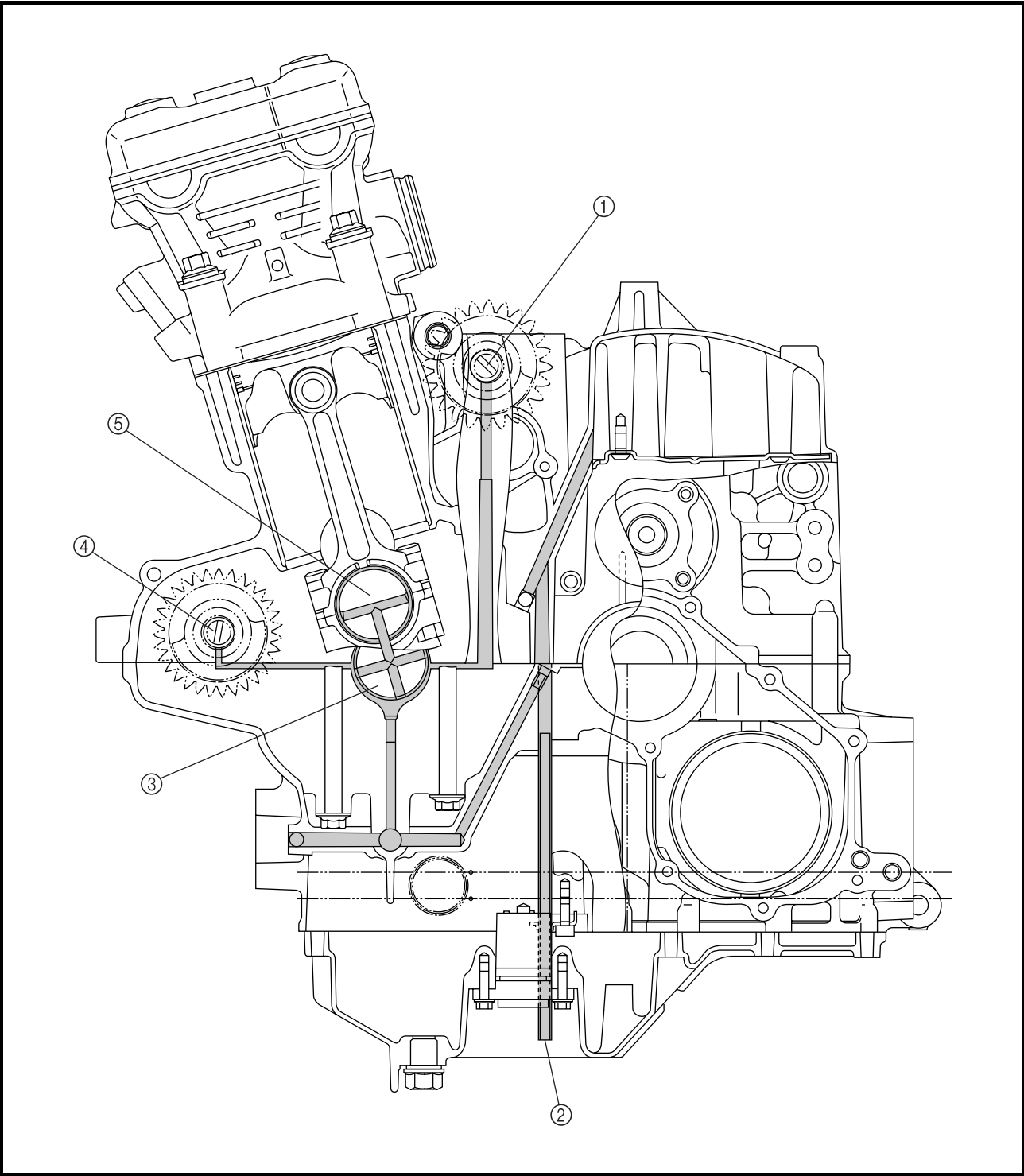

- ① Oil strainer
- ② Oil delivery pipe
- ③ Oil cooler
- ④ Engine oil drain bolt
- ⑤ Oil level switch
- ⑥ Oil filter cartridge
- ⑦ Oil pan
- ⑧ Oil pipe
- ⑨ Oil pump

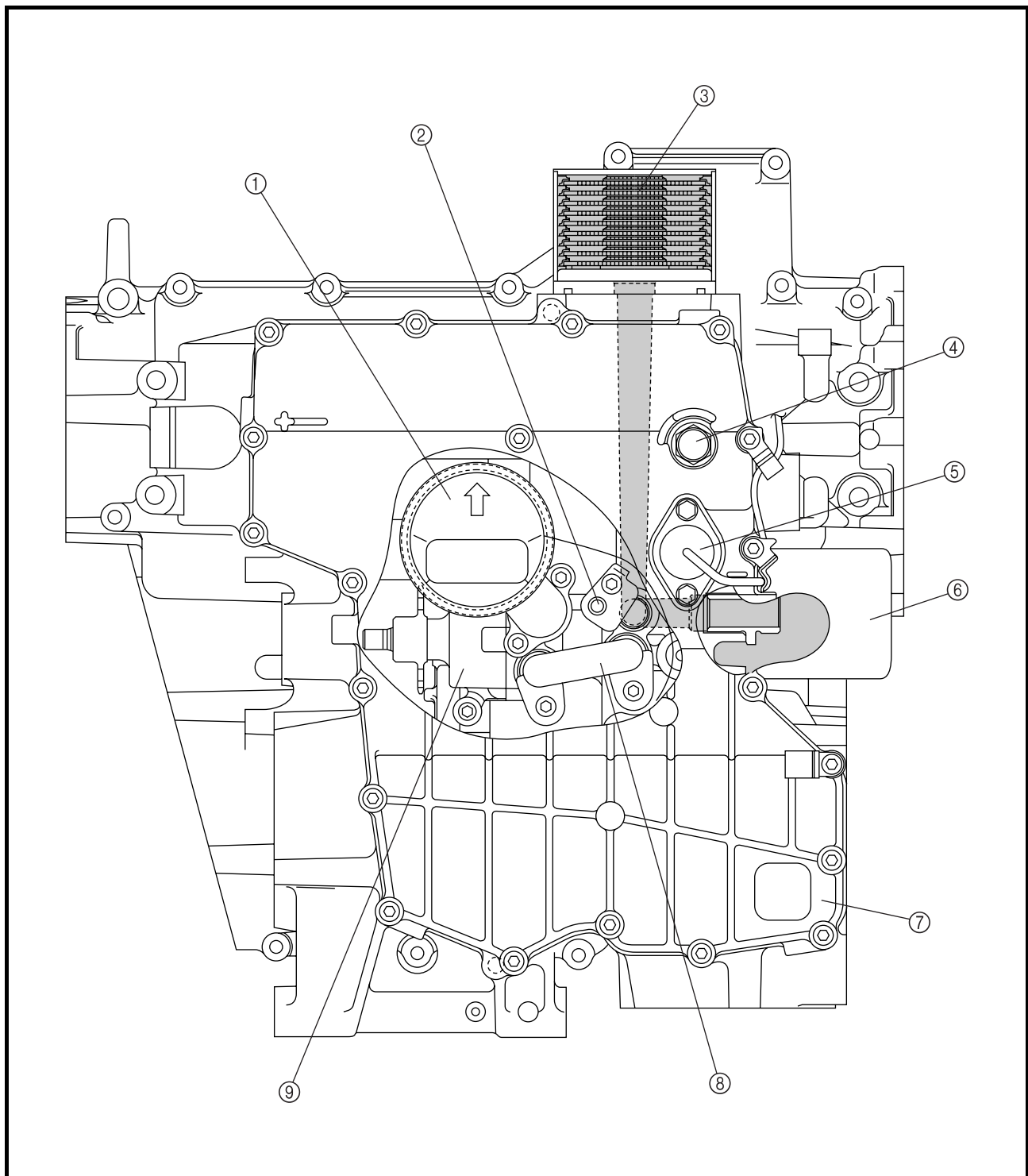

- ① Main axle
- ② Drive axle
- ③ Middle drive shaft

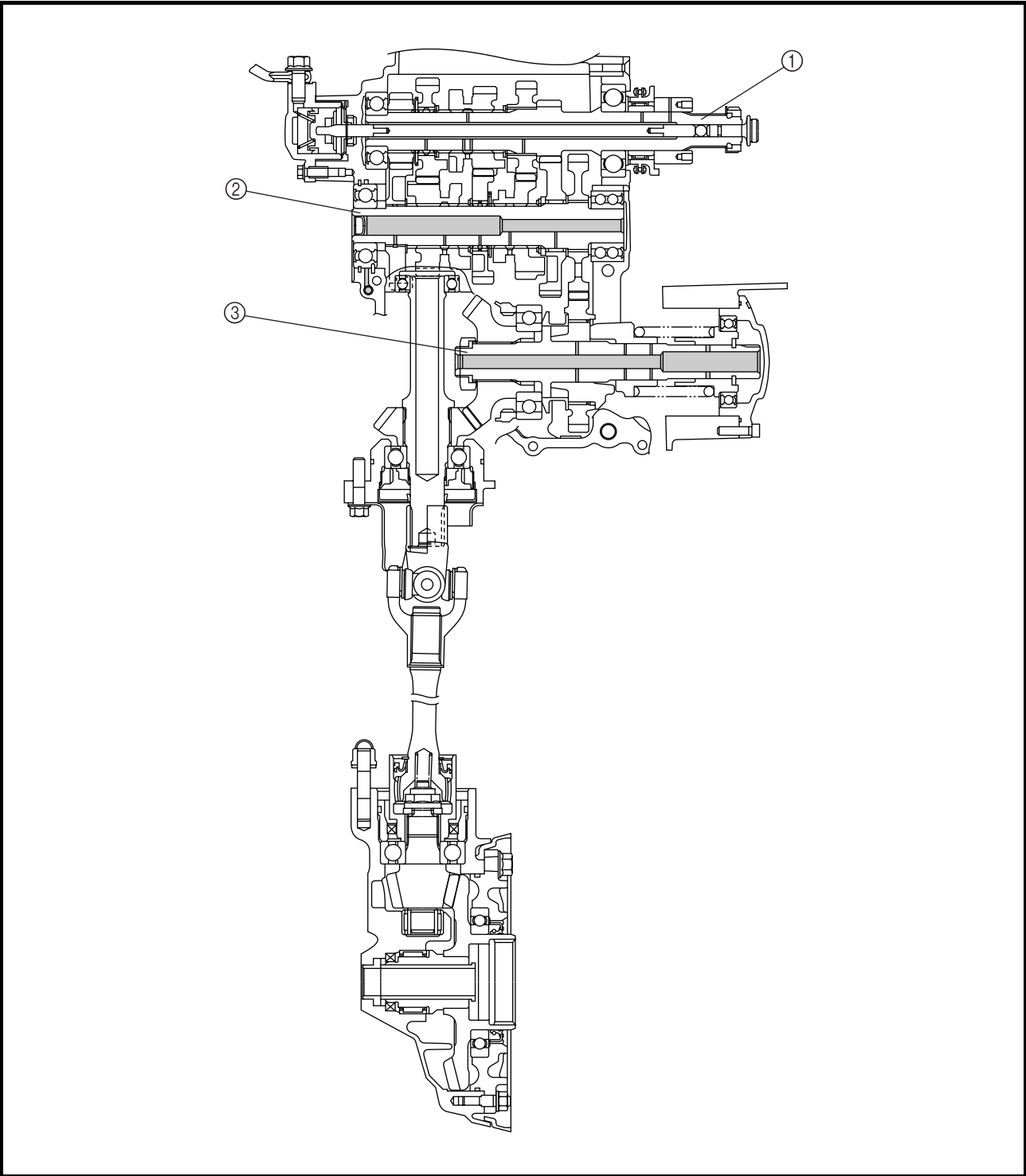



COOLING SYSTEM DIAGRAMS

① Radiator

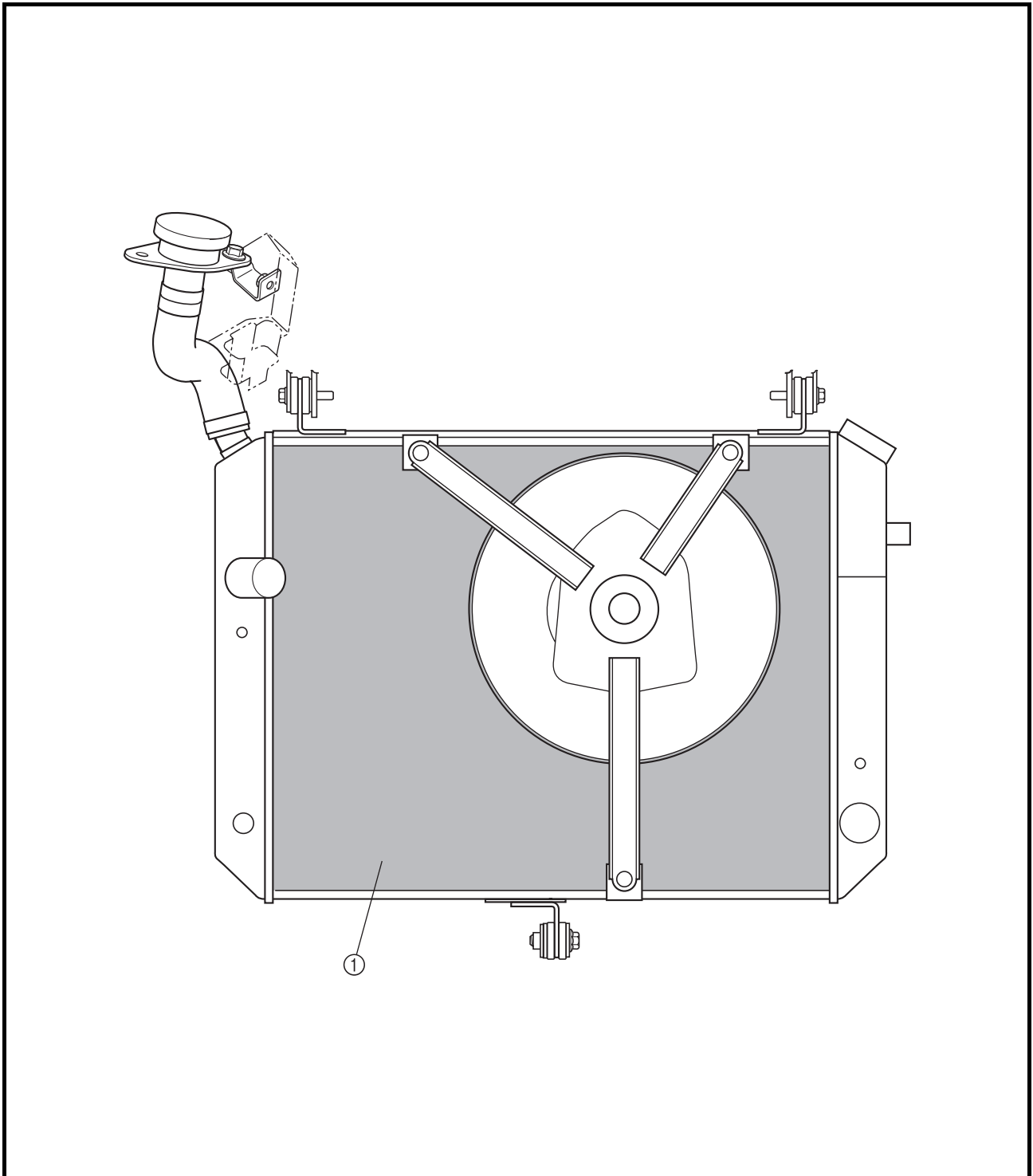



- ① Water jacket joint
- ② Oil cooler

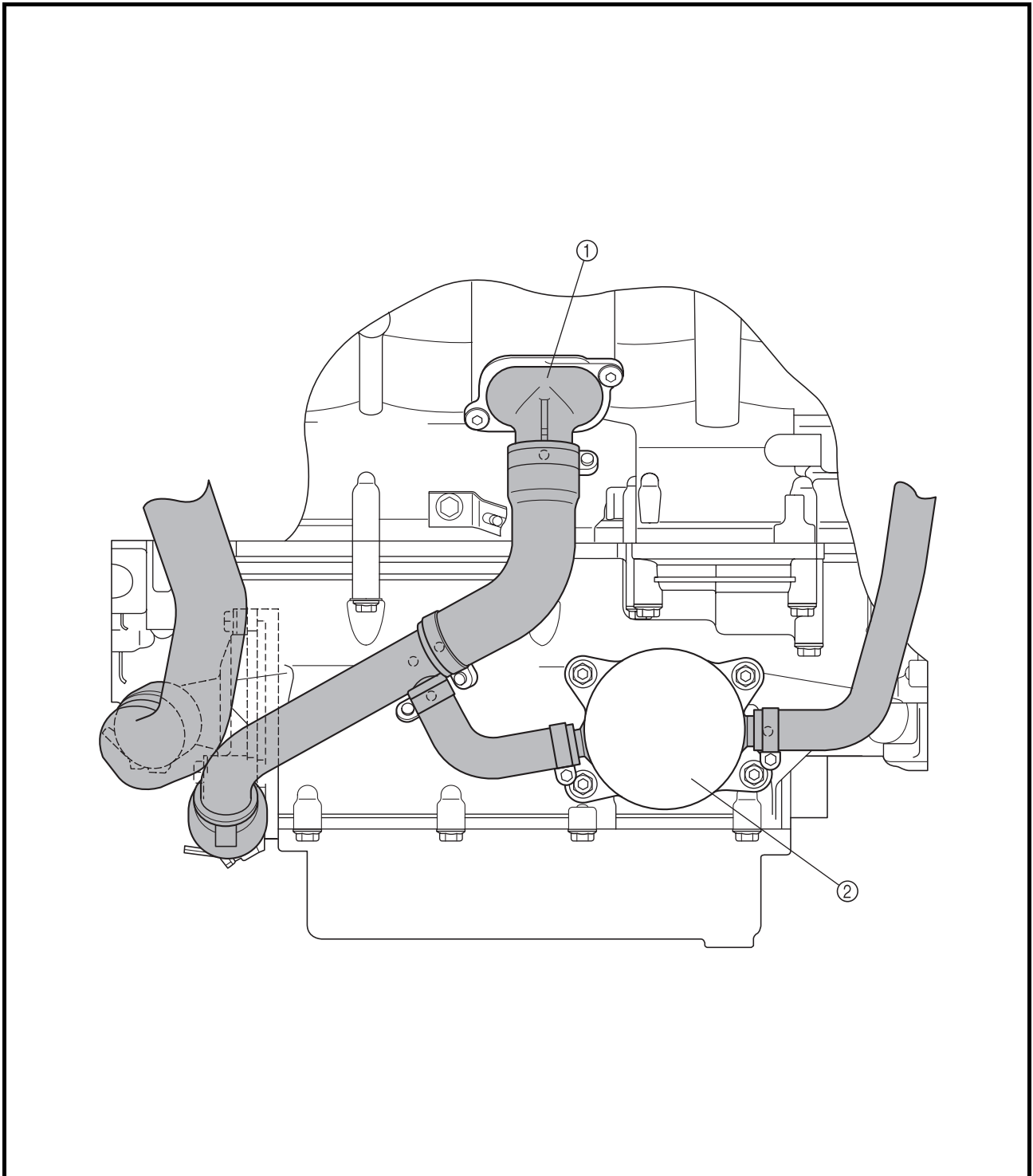



- ① Thermostat assembly
- ② Coolant reservoir
- ③ Radiator
- ④ Oil cooler

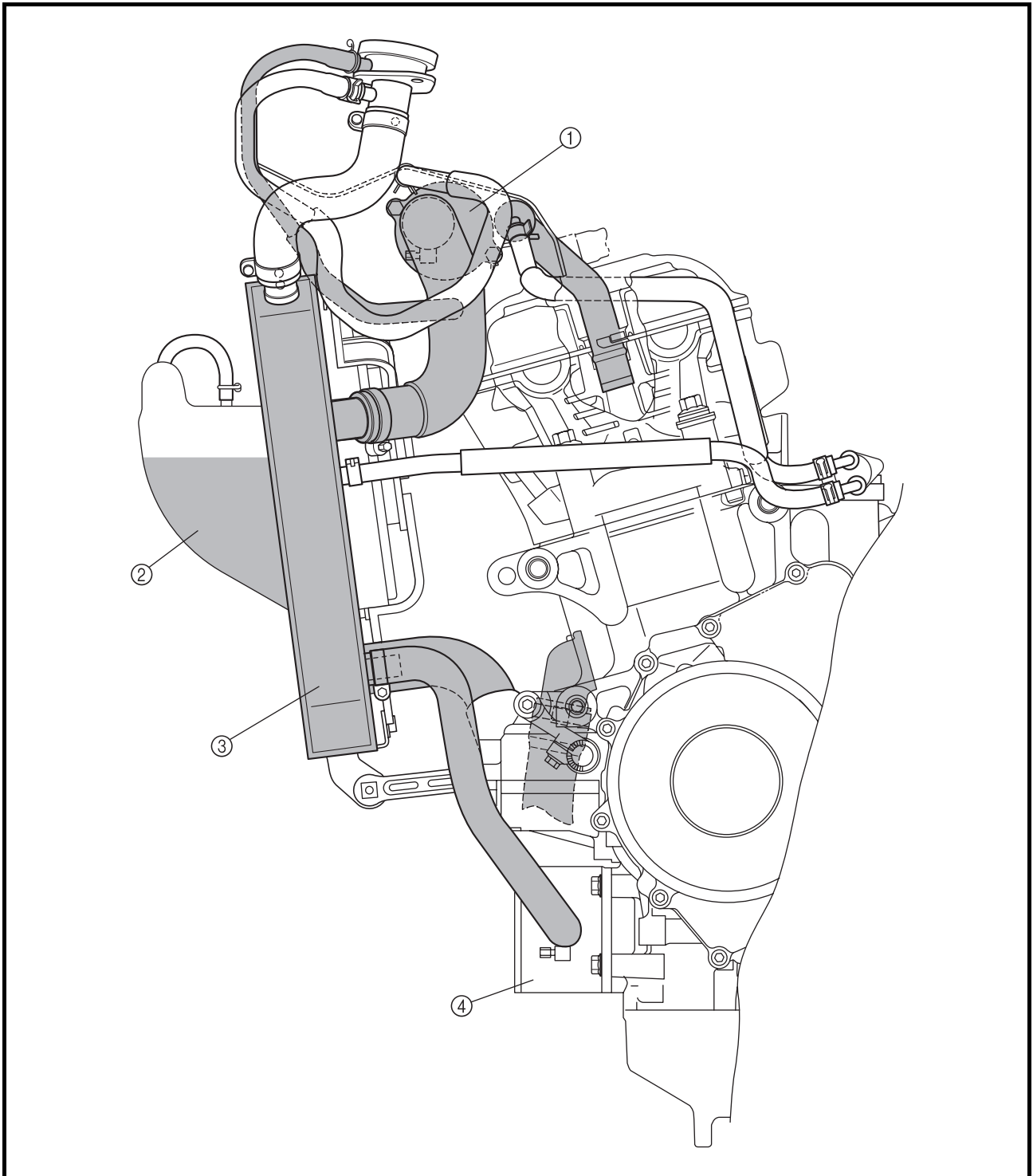



- ① Coolant reservoir
- ② Radiator
- ③ Water pump

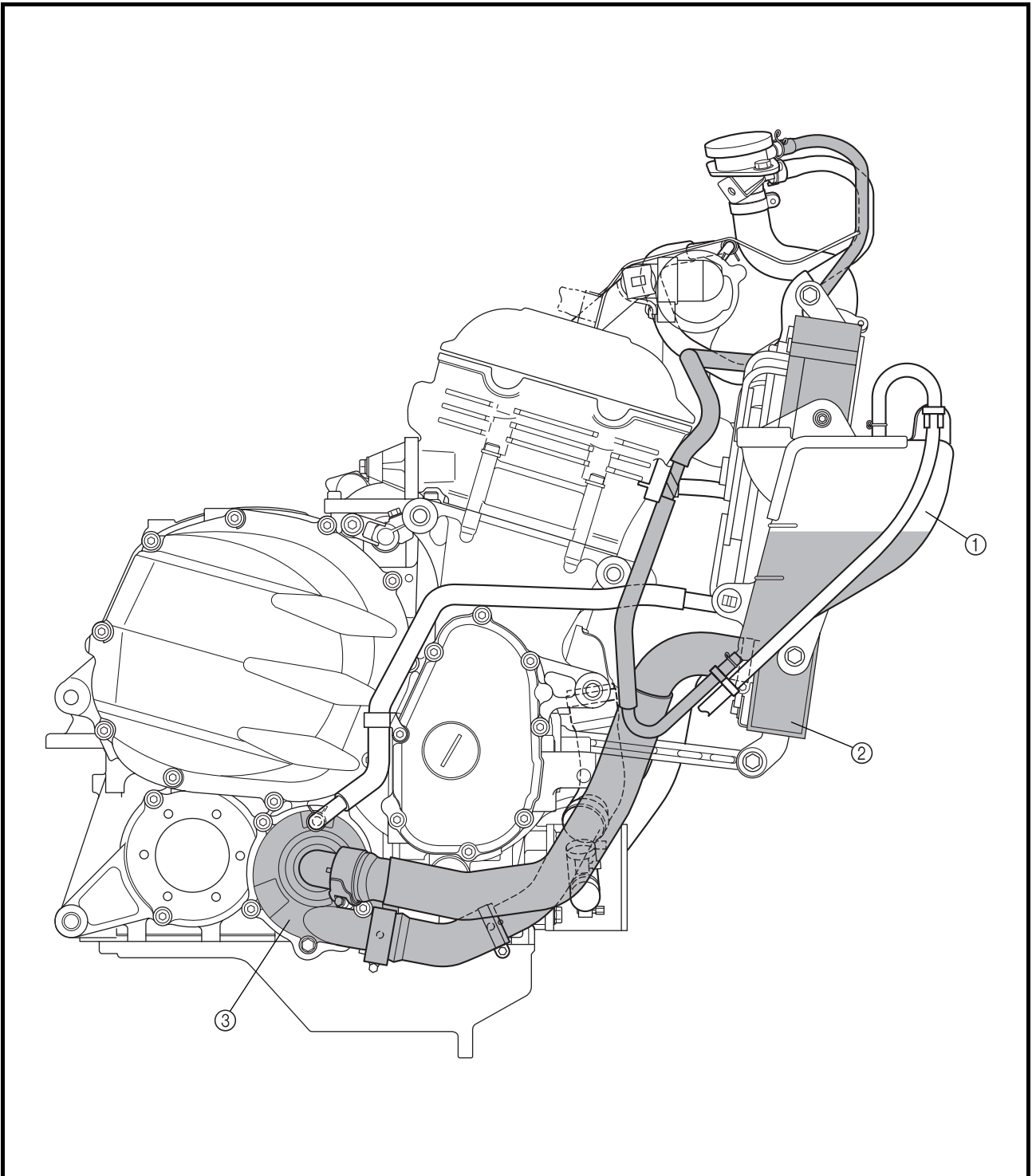



CABLE ROUTING

- ① Throttle cable
- ② Brake cable
- ③ Clutch cable
- ④ Main switch lead
- ⑤ Headlight lead
- ⑥ Fuse box
- ⑦ Thermostat assembly breather hose
- ⑧ Coolant reservoir hose
- ⑨ Hazard switch
- ⑩ Rectifier/regulator
- ⑪ Plate
- ⑫ Plunger control unit hose 2
- ⑬ Radiator
- ⑭ Radiator fan coupler

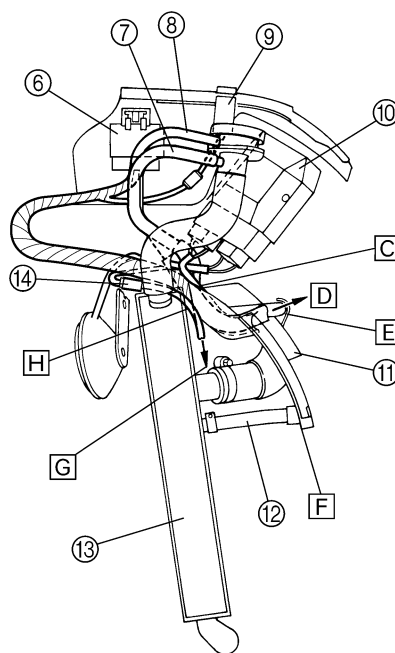
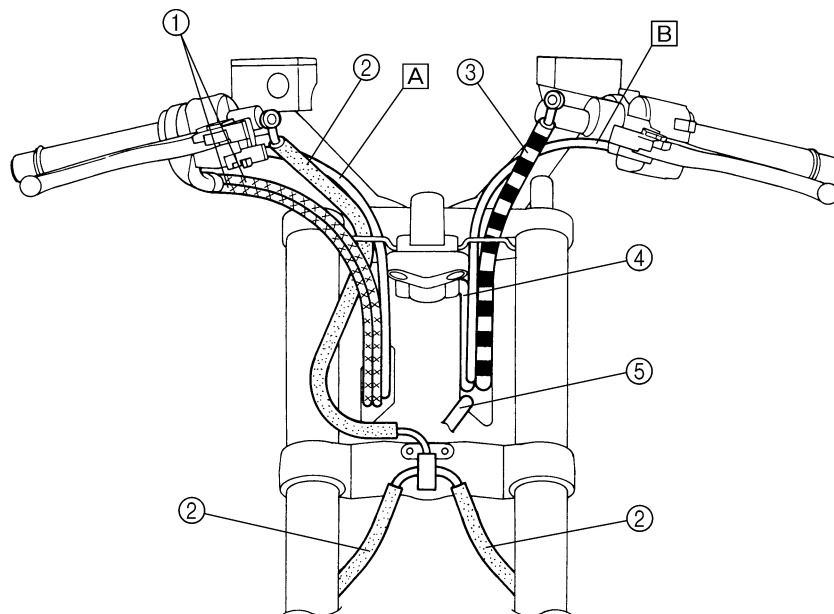



- A Pass the right handlebar switch lead under the handlebar.
- B Pass the left handlebar switch lead under the handlebar.
- C Pass the wire harness, stator coil lead, coolant reservoir hose, and thermostat assembly breather hose through the left slit of the plate.
- D To the thermostat housing
- E After passing the coolant reservoir hose through the two hose guides behind the plate, pass the hose through the right hole of the plate.
- F Pass the plunger control unit hose 2 on the inside of the plate.
- G To the radiator fan
- H Pass the radiator fan lead on the outside of the plate.

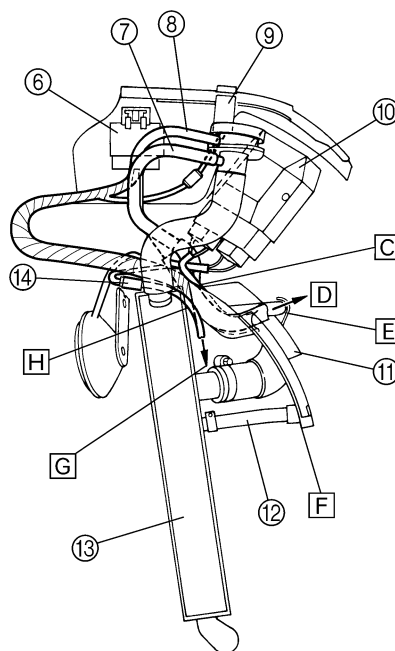
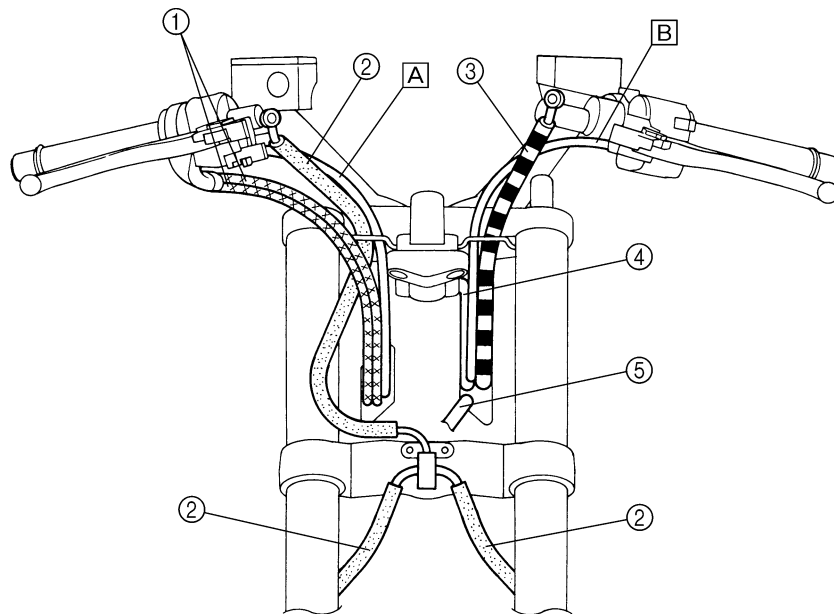



- ① Brake cable
- ② Right handlebar switch lead
- ③ Throttle cable
- ④ Starter relay
- ⑤ Battery
- ⑥ Positive battery lead
- ⑦ Main fuse
- ⑧ Front turn signal lead
- ⑨ Spark plug lead #4
- ⑩ Spark plug lead #1
- ⑪ Ignition coil lead (#1, #4)

- ⑫ Ignition coil (#1, #4)
- ⑬ Coolant reservoir
- ⑭ Coolant reservoir breather hose
- ⑮ Coolant reservoir hose
- ⑯ Pickup coil lead
- ⑰ Starter motor lead
- ⑱ Spark plug lead #2
- ⑲ Spark plug lead #3
- ⑳ Ignition coil (#2, #3)
- ㉑ Starter relay
- ㉒ Negative battery lead

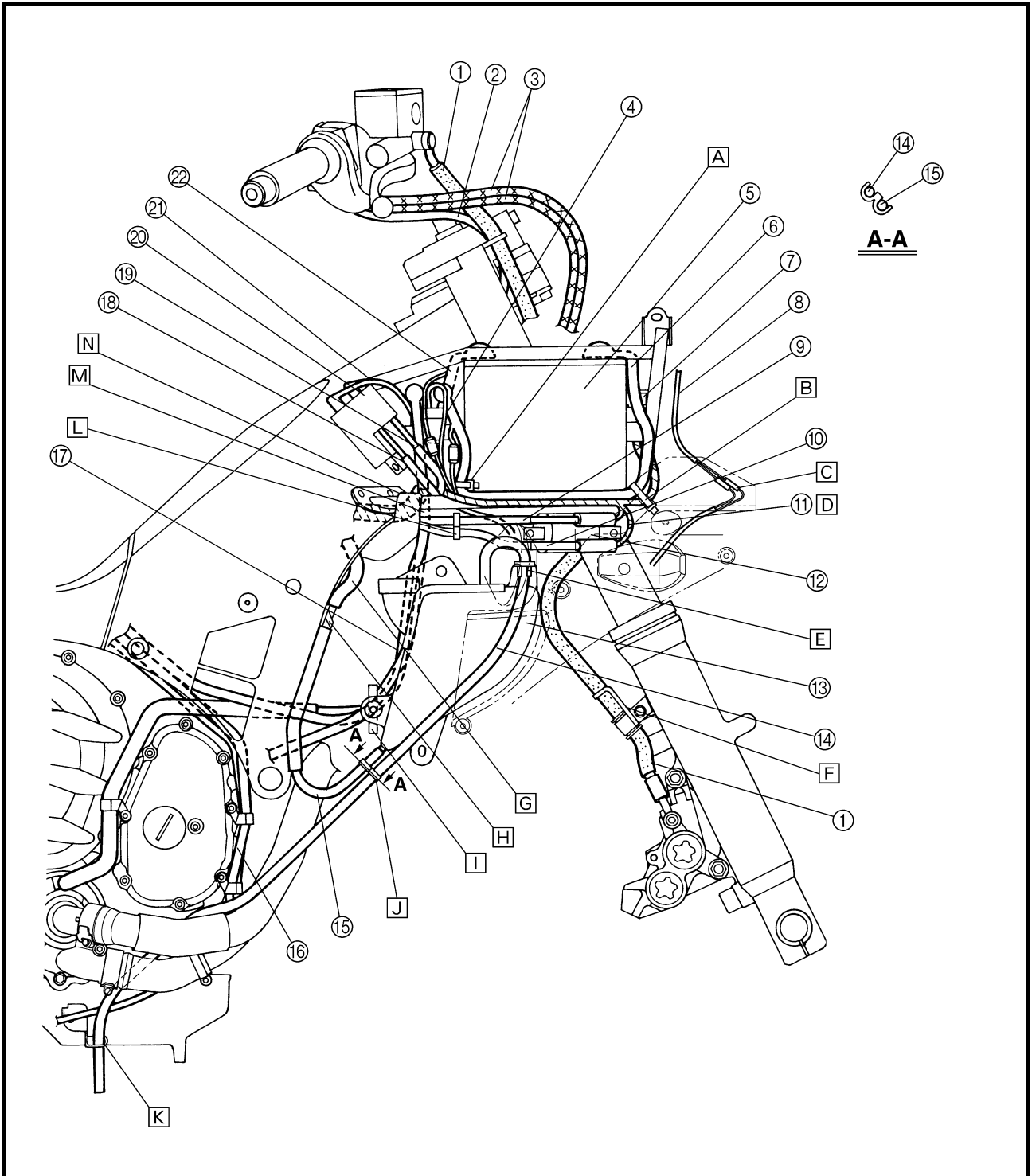



- [A] Fasten the positive battery lead with a plastic locking tie to the battery stay.
- [B] Fasten the positive battery lead and main fuse lead with a plastic locking tie to the battery stay.
- [C] Insert the front turn signal leads into the inner panel.
- [D] Install the connector so that the ignition coil lead can be turned outward.
- [E] Support the coolant reservoir breather hose with the hose holder attached to the coolant reservoir.
- [F] Pass the brake cable through the brake cable guide.
- [G] Pass the coolant reservoir hose through the hole of the plate.
- [H] Pass the coolant reservoir hose through the hose guide attached to the coolant reservoir.
- [I] Pass the negative battery lead and starter motor lead through the hose guide attached to the coolant reservoir.

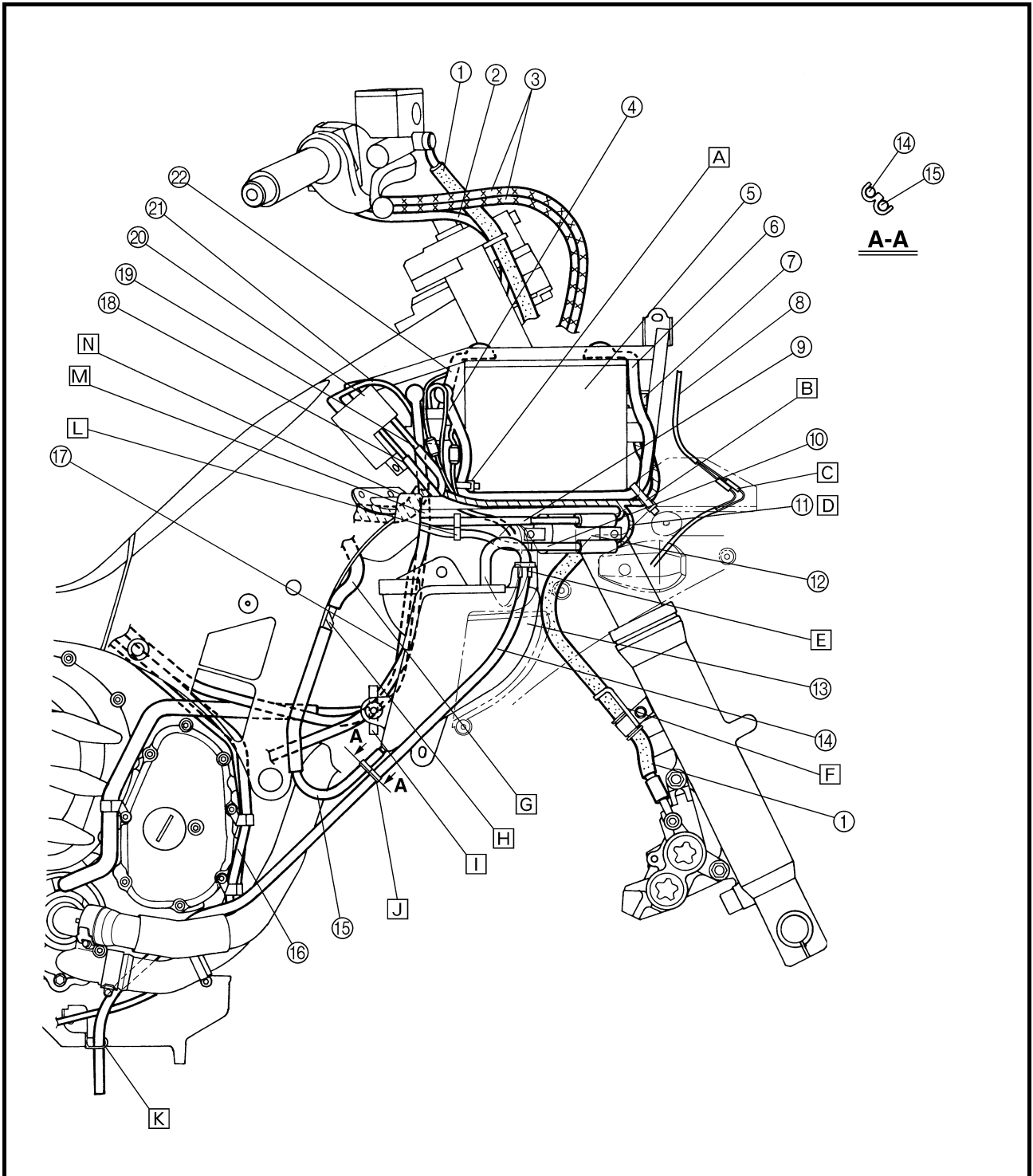



- J Support the coolant reservoir hose and coolant reservoir breather hose with the hose holder located under the coolant reservoir.
- K Pass the coolant reservoir hose through the hole of the coolant reservoir hose holder.
- L Fasten spark plug lead #1 and #4 at the number tag.
- M Pass the wire harness, spark plug leads #1, #2, and #3 through the right slit of the battery bracket.

- N Pass the starter motor lead, negative battery lead, and spark plug leads #2 and #3 through the battery stay. Be sure to pass the starter motor lead and negative battery lead on the battery stay side.

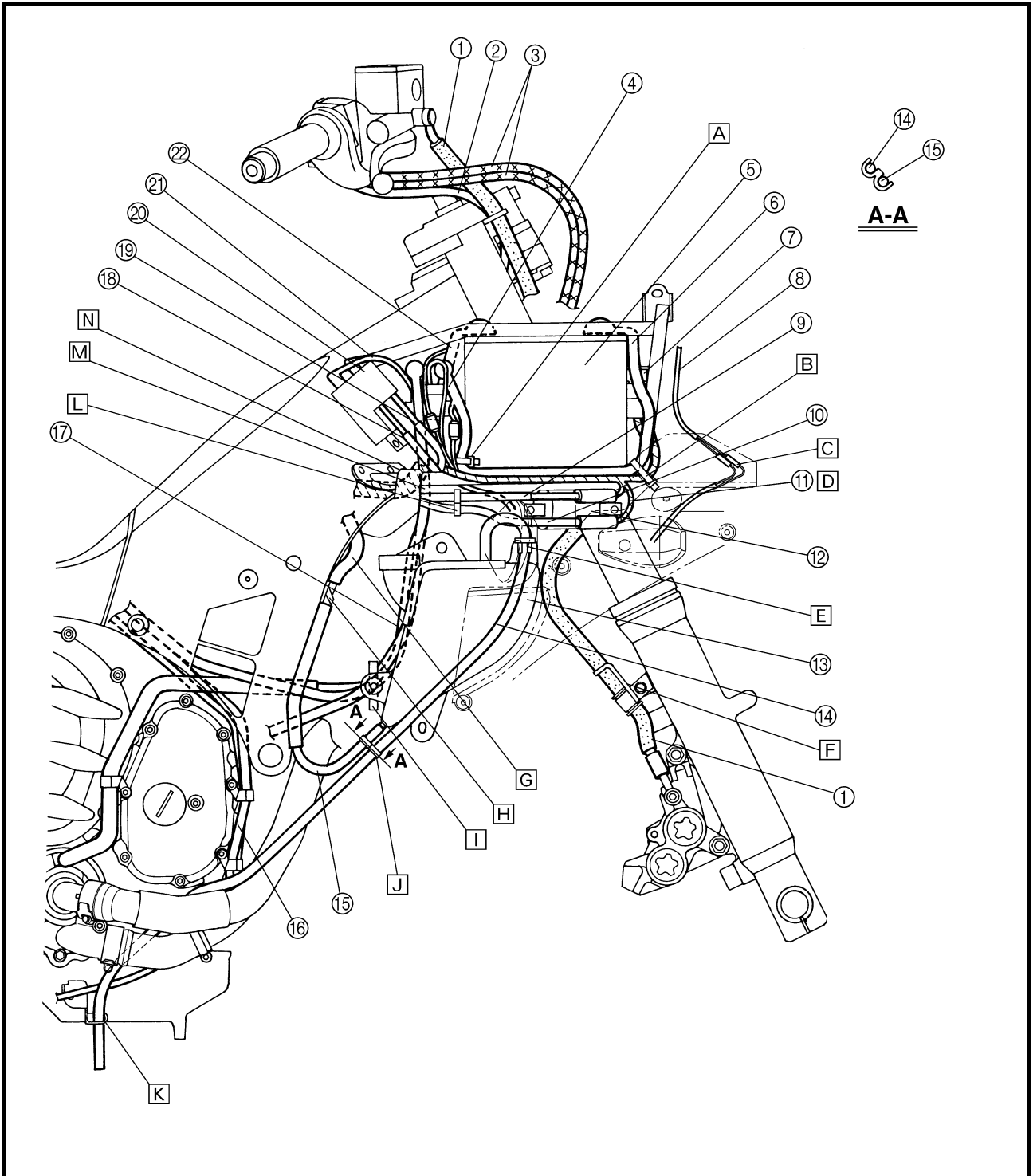



① Tail/brake light lead

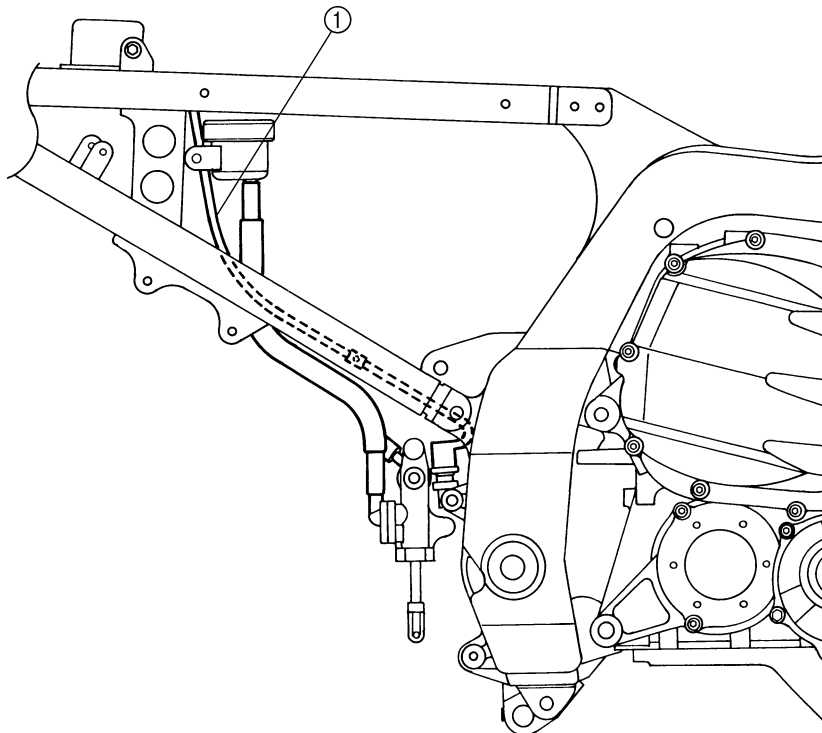

CABLE ROUTING

SPEC



- ① Main switch lead
- ② Left handlebar switch lead
- ③ Hazard switch
- ④ Rectifier/regulator
- ⑤ Clutch cable
- ⑥ Fuel tank overflow hose
- ⑦ Fuel tank breather hose
- ⑧ Stator coil lead
- ⑨ Sidestand switch
- ⑩ Sidestand switch lead
- ⑪ Oil level switch lead
- ⑫ Brake cable
- ⑬ Coolant reservoir hose
- ⑭ Thermostat assembly breather hose
- ⑮ Headlight lead
- ⑯ Radiator fan lead
- ⑰ Wire harness

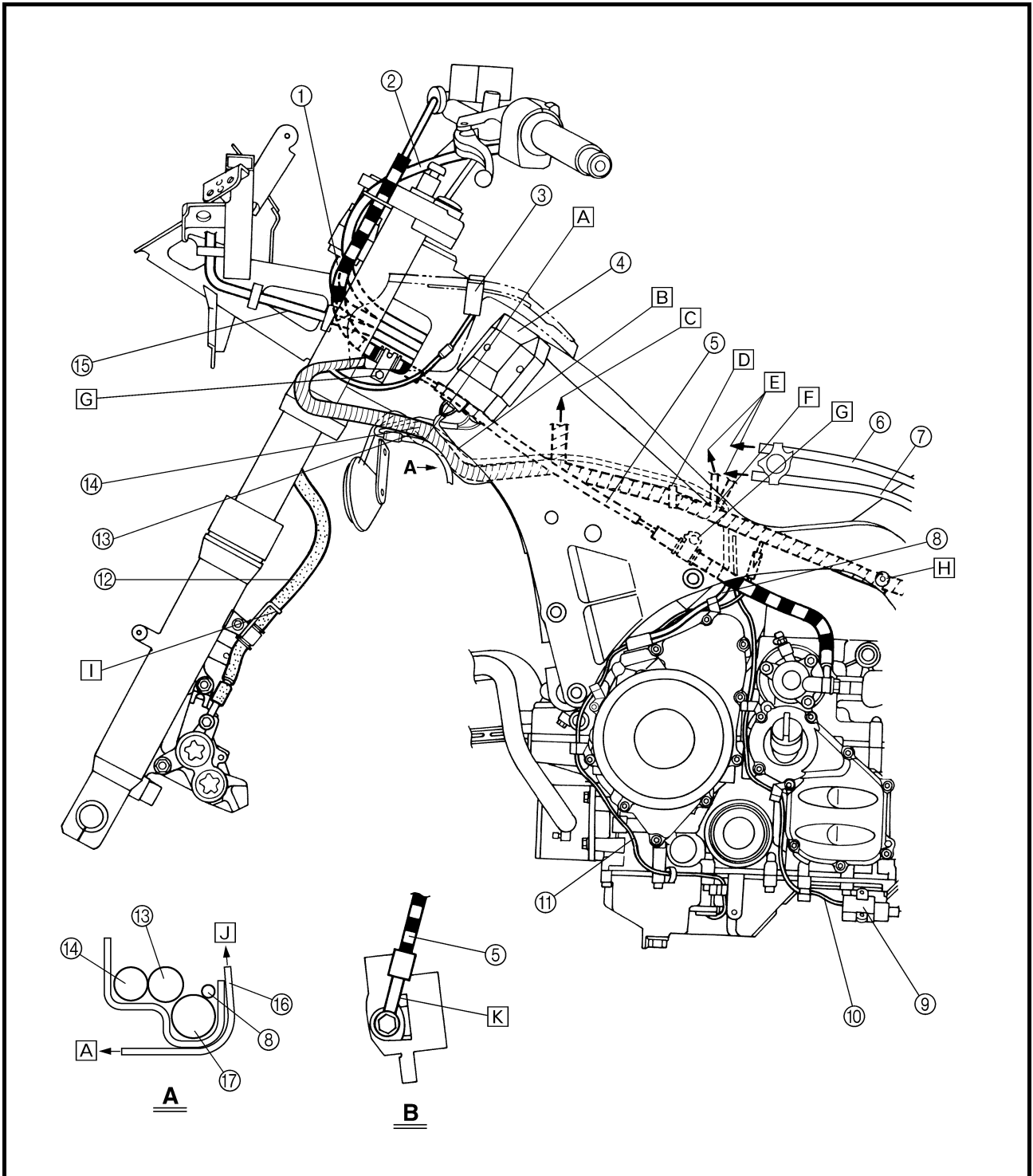

CABLE ROUTING

SPEC



- A** To the radiator fan
- B** Pass the wire harness, stator coil lead, coolant reservoir hose, and thermostat assembly breather hose through the left slit of the plate.
- C** To the right side of the frame
- D** Clamp the wire harness with the plastic band attached to the frame.
- E** To the fuel tank
- F** Pass the stator coil lead at the fork of the wire harness.

- G** Support the harness holder into the hole on the rear end of the frame.
- H** Insert the harness holder into the hole on the rear end of the frame.
- I** Pass the brake cable through the brake cable guide.
- J** To the wire harness
- K** Contact the clutch cable to the turn stopper.

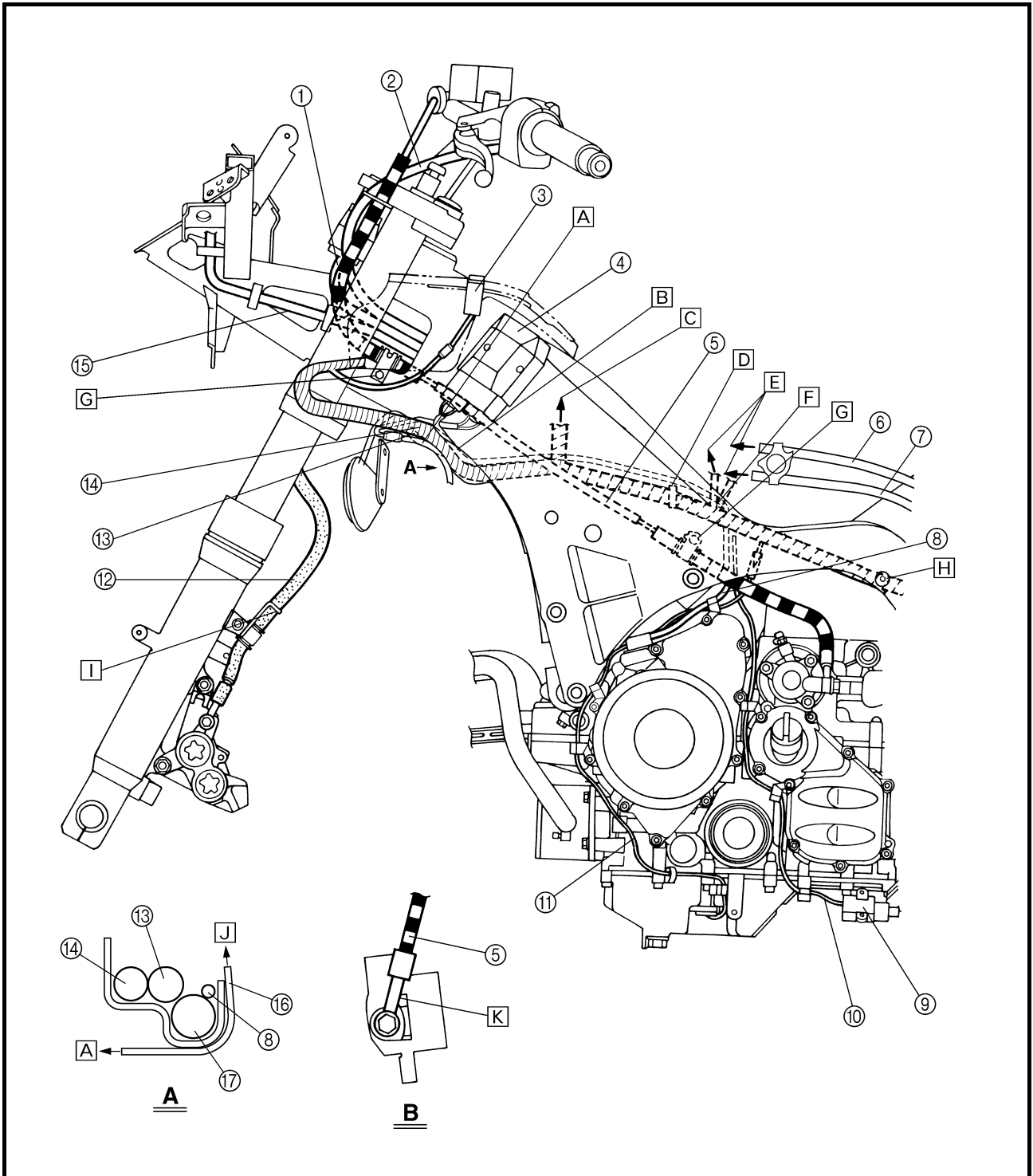



- ① ECU
 - ② Tail/brake light lead
 - ③ Seat lock cable
 - ④ Fuel tank breather hose
 - ⑤ Fuel tank overflow hose
 - ⑥ Air filter case breather hose
- A To the intake air temperature sensor
 - B Fasten the wire harness with a plastic band to the frame.
 - C To the inside of the U-lock storage box
 - D Fasten the tail/brake light lead with a plastic band to the frame.
 - E Pass the tail/brake light lead between the rear cover and frame.
 - F Pass the wire harness on the inside of the seat lock cable.
 - G Support the wire harness and ignitor unit lead with the cable holder attached to the tray.
 - H Pass the fuel tank breather hose and fuel tank overflow hose through the hose guide.
 - I Pass the fuel tank breather hose and fuel tank overflow hose between the swingarm and universal joint.

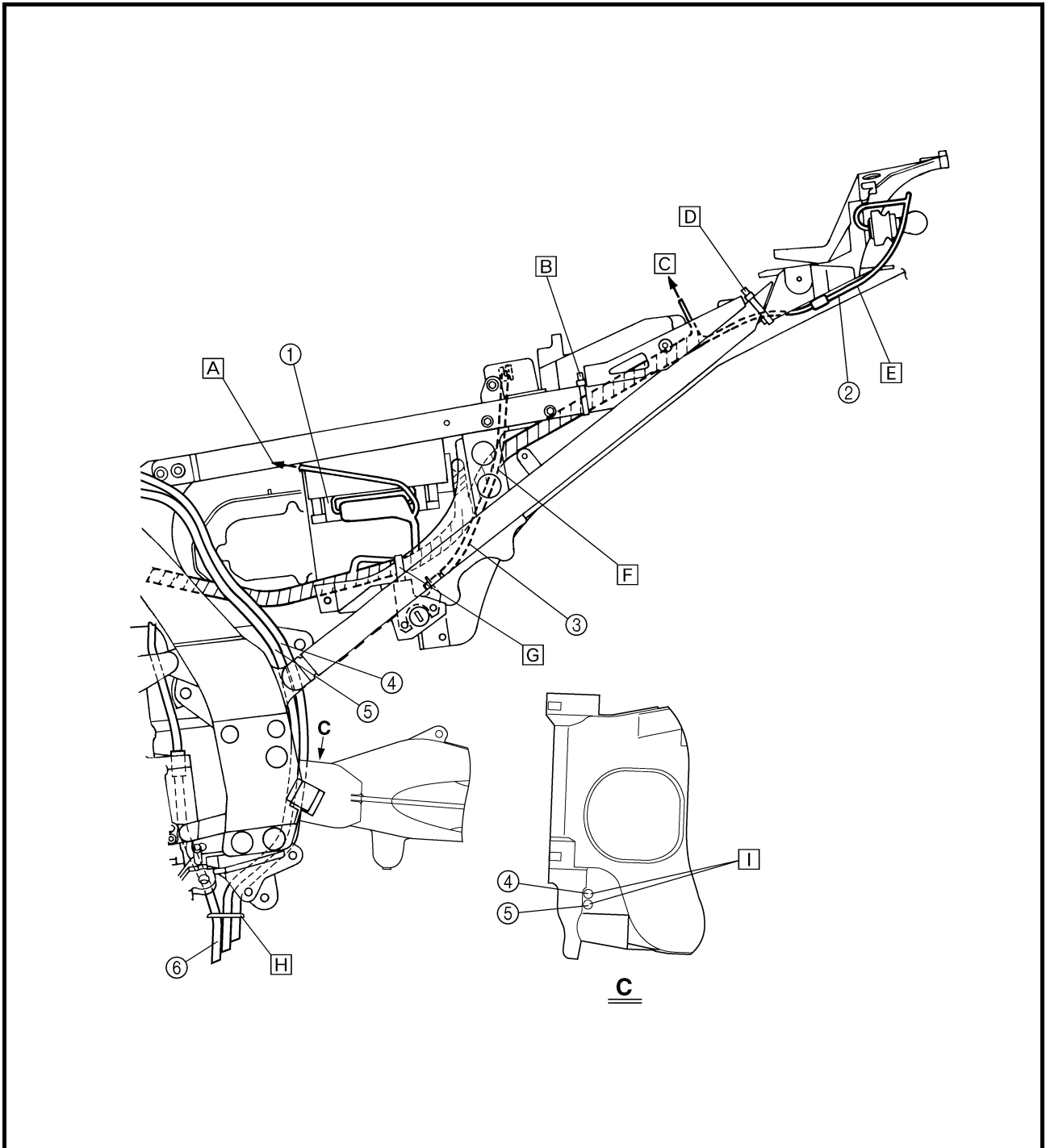

CABLE ROUTING

SPEC



- ① Air cut-off valve
- ② Clutch cable
- ③ Left handlebar switch lead
- ④ Headlight lead
- ⑤ Main switch lead
- ⑥ Throttle cable
- ⑦ Right handlebar switch lead
- ⑧ T-bar
- ⑨ Spark plug lead #3
- ⑩ Spark plug lead #2

- ⑪ Spark plug lead #1
- ⑫ Spark plug lead #4
- ⑬ Throttle position sensor
- ⑭ Sidestand switch lead
- ⑮ Spark plug lead #1
- ⑯ Spark plug lead #4

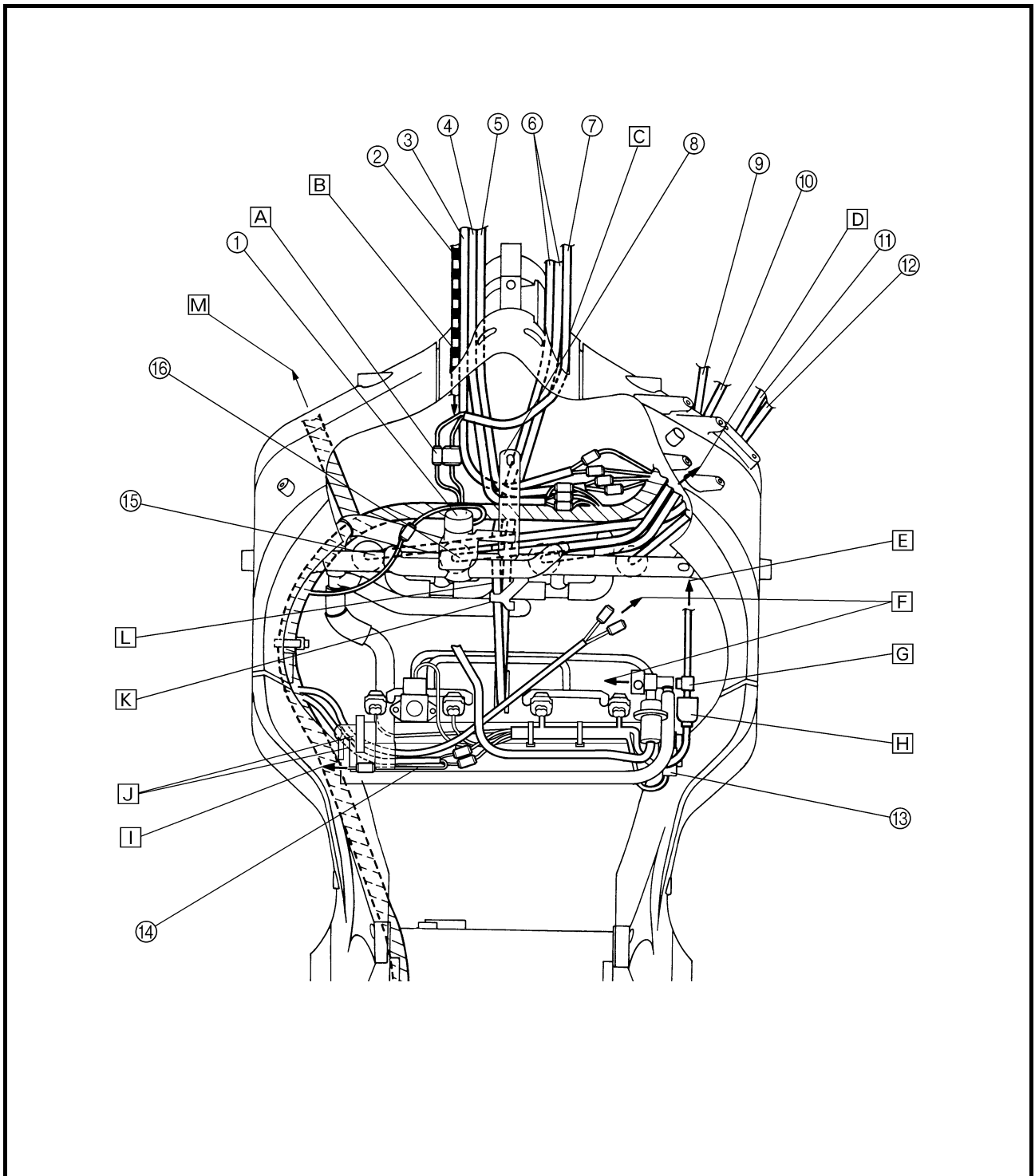

CABLE ROUTING

SPEC



- A Connect the wire harness and right handlebar switch lead.
- B Pass the left handlebar switch lead, main switch lead, headlight lead, and clutch cable through the hole on the left side of the frame.
- C Pass the right handlebar and throttle cables through the hole on the right side of the frame.
- D To the lower left slit of the plate
- E To the camshaft sensor
- F To the fuel tank
- G Pass the camshaft sensor lead through the lead guide of throttle body.
- H After connecting the camshaft sensor lead, cover it with a rubber cover.
- I To the sidestand switch lead
- J Pass the camshaft sensor lead under the fuel hose and then to the wire harness.

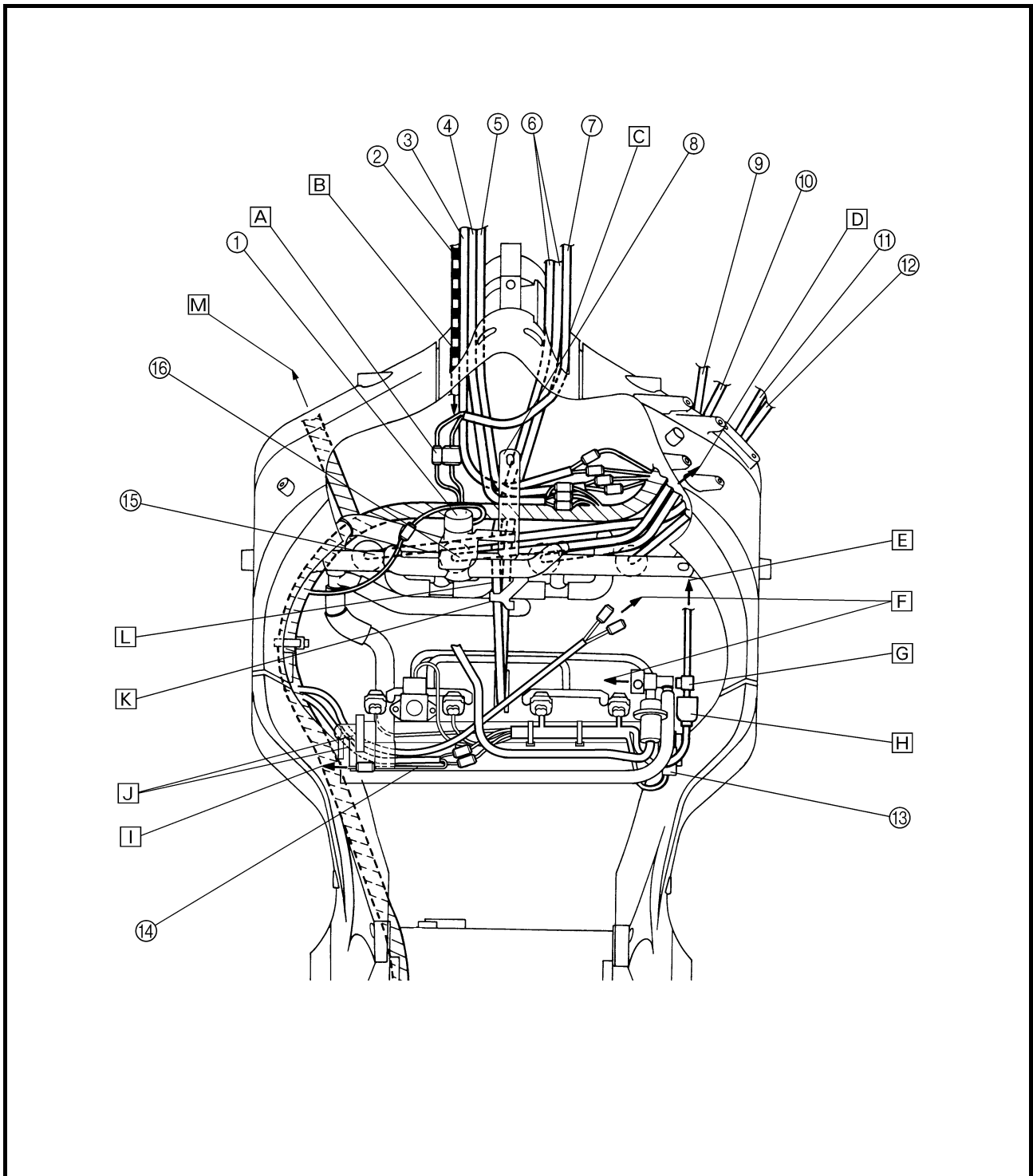



- K** Support the throttle cables with the T-bar located behind the cable guide.
- L** Pass the throttle cables under spark plug leads #1, #2, #3, and #4, and the wire harness, headlight lead, main switch lead, right handlebar switch lead, and left handlebar switch lead. Install the thermostat, heat protector, throttle cables, spark plug leads, wire harnesses, and air cut valve under the cable guide in the respective order.
- M** To the left slit of the plate

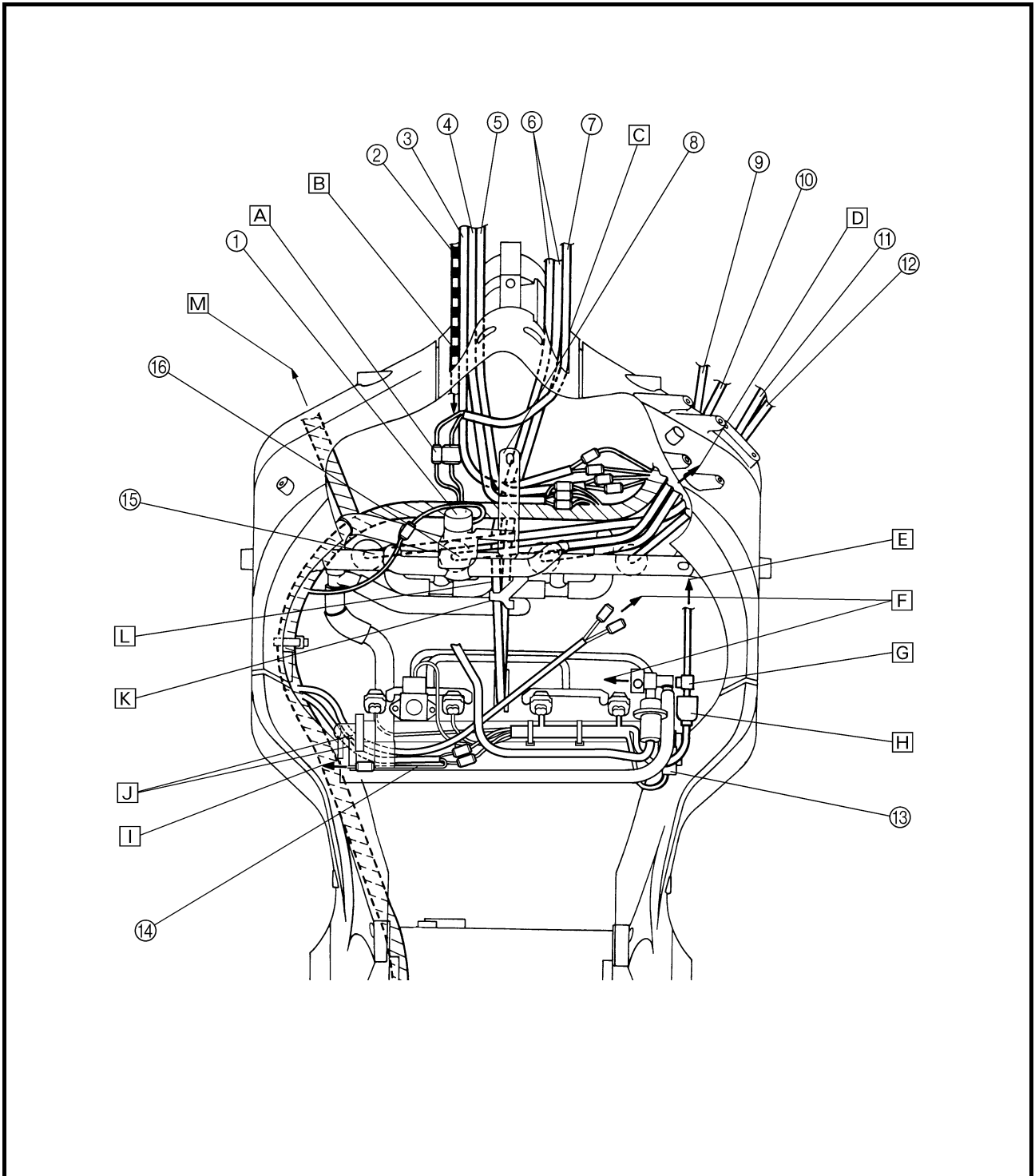



- ① Engine stop switch
- ② Starting circuit cut-off relay
- ③ Atmospheric pressure sensor
- ④ CYCLELOCK coupler
- ⑤ Seat lock cable

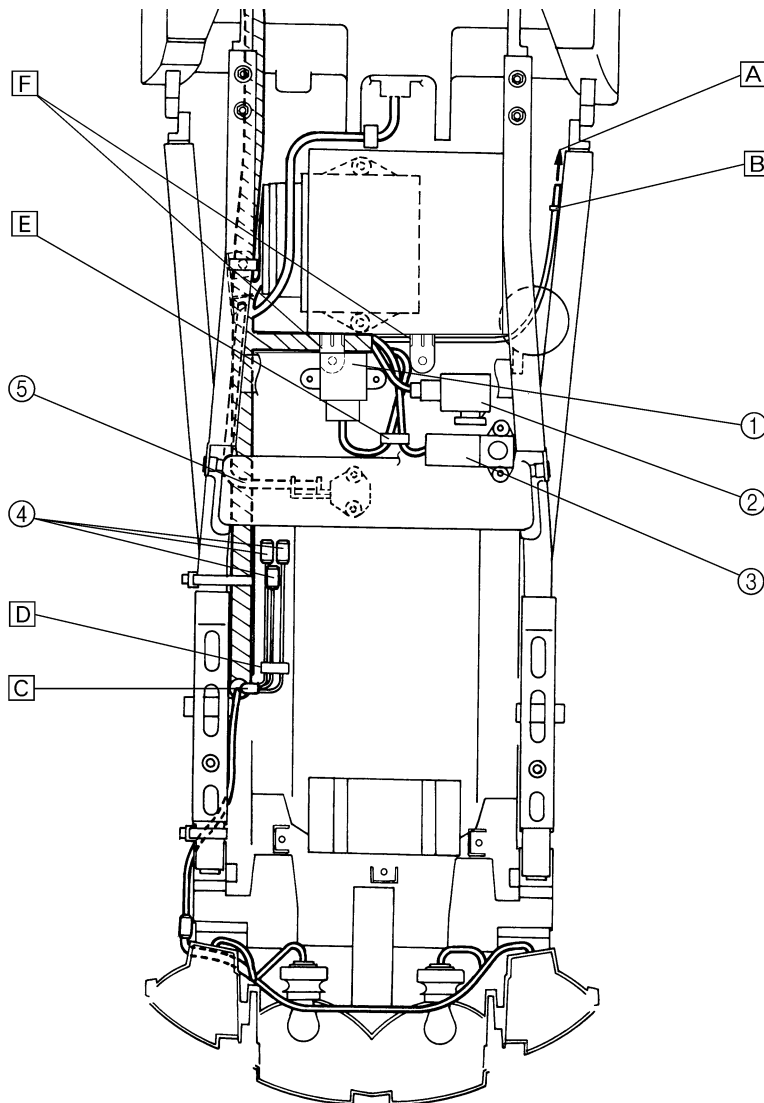



- A To the rear brake light switch
- B Pass the engine stop switch through the lead guide attached to the frame.
- C Pass the security lead coupler through the inside of the storage box of the U-lock.
- D Pass the security lead coupler through the lead guide.
- E Pass the pressure sensor lead and engine stop switch lead through the lead guide.
- F Pass the wire harnesses under the tray bracket.

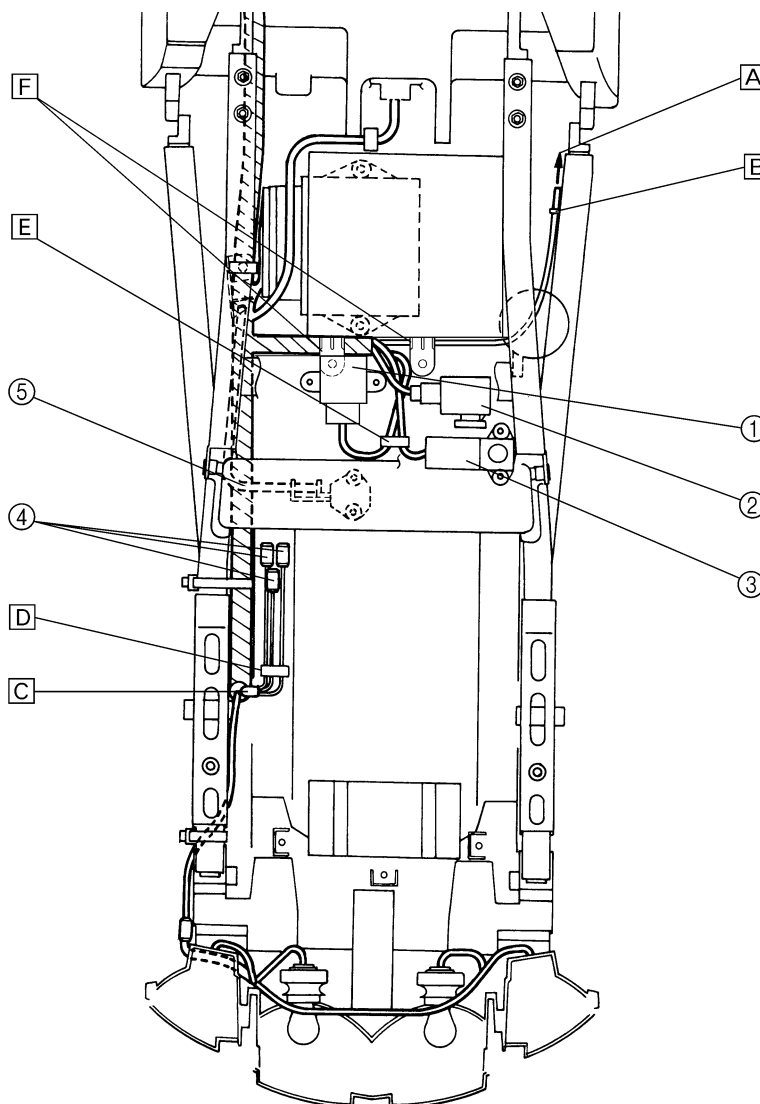

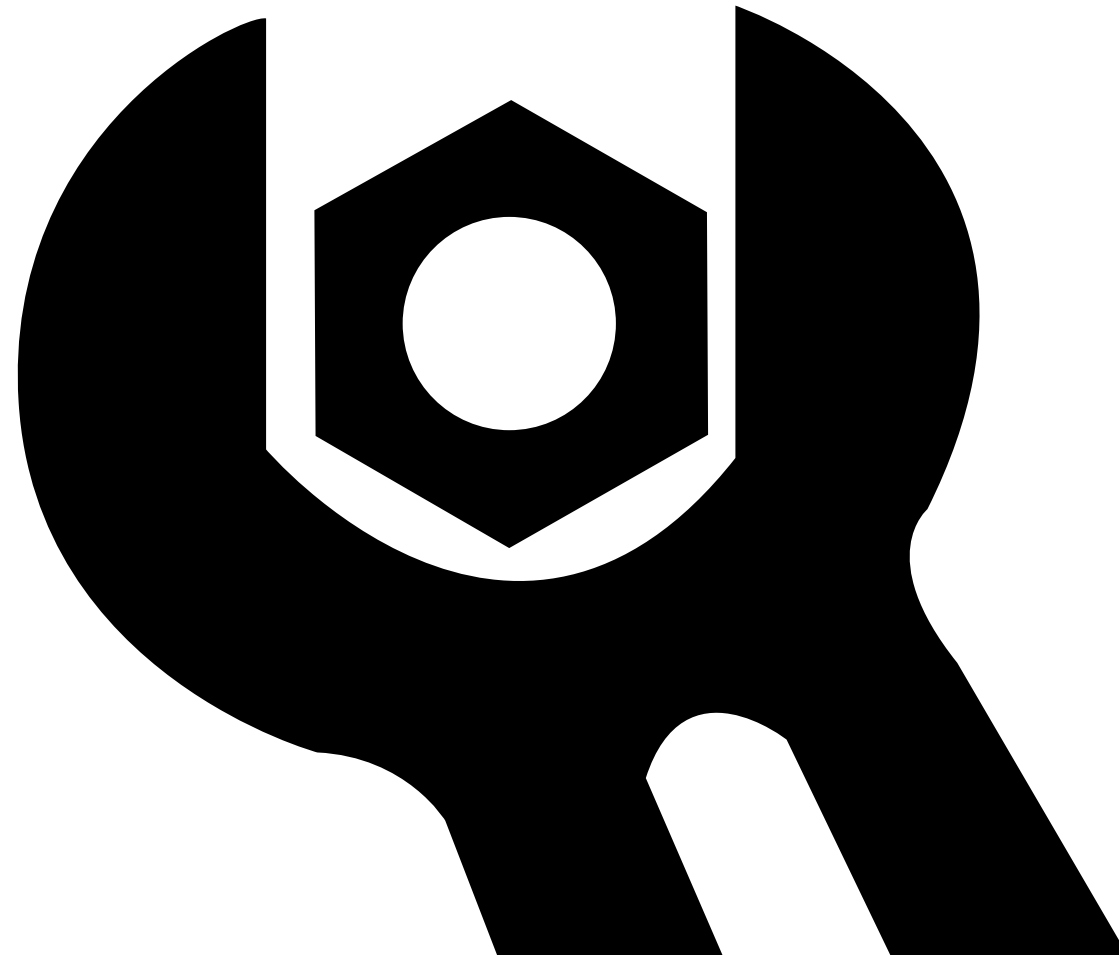

CHK

ADJ

3

CHAPTER 3

PERIODIC CHECKS AND ADJUSTMENTS

INTRODUCTION	3-1
PERIODIC MAINTENANCE AND LUBRICATION INTERVALS	3-1
SEATS AND FUEL TANK	3-3
SEATS.....	3-3
FUEL TANK.....	3-4
T-BAR.....	3-5
REMOVING THE FUEL TANK	3-6
REMOVING THE FUEL PUMP	3-6
INSTALLING THE FUEL PUMP.....	3-7
INSTALLING THE FUEL HOSE	3-7
INSTALLING THE T-BAR.....	3-7
AIR FILTER CASE	3-8
COWLINGS AND COVERS	3-10
COWLINGS	3-10
COVERS	3-14
ENGINE	3-15
ADJUSTING THE VALVE CLEARANCE	3-15
SYNCHRONIZING THE THROTTLE BODIES.....	3-21
CHECKING AND ADJUSTING THE EXHAUST GAS AT IDLE	3-23
ADJUSTING THE EXHAUST GAS VOLUME	3-25
CHECKING THE EXHAUST GAS AT IDLE	3-27
ADJUSTING THE ENGINE IDLING SPEED	3-28
ADJUSTING THE THROTTLE CABLE FREE PLAY	3-30
CHECKING THE SPARK PLUGS.....	3-32
CHECKING THE IGNITION TIMING.....	3-33
MEASURING THE COMPRESSION PRESSURE.....	3-35
CHECKING THE ENGINE OIL LEVEL.....	3-37
CHANGING THE ENGINE OIL	3-39
MEASURING THE ENGINE OIL PRESSURE	3-41
ADJUSTING THE CLUTCH LEVER.....	3-43
CHECKING THE CLUTCH FLUID LEVEL	3-43
BLEEDING THE HYDRAULIC CLUTCH SYSTEM	3-44
CLEANING THE AIR FILTER ELEMENT.....	3-46
CHECKING THE THROTTLE BODY JOINTS	3-47
CHECKING THE FUEL AND VACUUM HOSES	3-48
CHECKING THE CRANKCASE BREATHER HOSE	3-48
CHECKING THE EXHAUST SYSTEM.....	3-49
CHECKING THE COOLANT LEVEL.....	3-50
CHECKING THE COOLING SYSTEM	3-51
CHANGING THE COOLANT.....	3-52

CHASSIS	3-55
ADJUSTING THE FRONT BRAKE	3-55
ADJUSTING THE REAR BRAKE	3-56
CHECKING THE BRAKE FLUID LEVEL.....	3-57
CHECKING THE BRAKE PADS	3-58
ADJUSTING THE REAR BRAKE LIGHT SWITCH	3-58
CHECKING THE BRAKE HOSES.....	3-59
BLEEDING THE HYDRAULIC BRAKE SYSTEM	3-60
ADJUSTING THE SHIFT PEDAL.....	3-61
CHECKING THE FINAL DRIVE OIL LEVEL	3-62
CHANGING THE FINAL DRIVE OIL	3-62
CHECKING AND ADJUSTING THE STEERING HEAD	3-63
CHECKING THE FRONT FORK.....	3-65
ADJUSTING THE FRONT FORK LEGS	3-66
ADJUSTING THE REAR SHOCK ABSORBER ASSEMBLY	3-68
CHECKING THE TIRES.....	3-69
CHECKING THE WHEELS	3-71
CHECKING AND LUBRICATING THE CABLES	3-72
LUBRICATING THE LEVERS AND PEDALS	3-72
LUBRICATING THE SIDESTAND.....	3-72
LUBRICATING THE CENTERSTAND	3-73
LUBRICATING THE REAR SUSPENSION.....	3-73
 ELECTRICAL SYSTEM	 3-74
CHECKING AND CHARGING THE BATTERY	3-74
CHECKING THE FUSES	3-79
REPLACING THE HEADLIGHT BULBS	3-81
ADJUSTING THE HEADLIGHT BEAMS.....	3-82

EAS00036

PERIODIC CHECKS AND ADJUSTMENTS

INTRODUCTION

This chapter includes all information necessary to perform recommended checks and adjustments. If followed, these preventive maintenance procedures will ensure more reliable vehicle operation, a longer service life and reduce the need for costly overhaul work. This information applies to vehicles already in service as well as to new vehicles that are being prepared for sale. All service technicians should be familiar with this entire chapter.

EAS00037

PERIODIC MAINTENANCE AND LUBRICATION INTERVALS

NOTE: _____

- The annual checks must be performed every year, except if a kilometer-based maintenance is performed instead.
- From 50,000 km, repeat the maintenance intervals starting from 10,000 km.
- Items marked with an asterisk should be performed by a Yamaha dealer as they require special tools, data and technical skills.

No.	ITEM	CHECK OR MAINTENANCE JOB	ODOMETER READING (× 1,000 km)					ANNUAL CHECK
			1	10	20	30	40	
1	* Fuel line (See page 3-48)	• Check fuel hoses for cracks or damage.		√	√	√	√	√
2	Spark plugs (See page 3-32)	• Check condition. • Clean and regap.		√		√		
		• Replace.			√		√	
3	* Valves (See page 3-15)	• Check valve clearance. • Adjust.	Every 40,000 km					
4	Air filter element (See page 3-46)	• Clean.		√		√		
		• Replace.			√		√	
5	* Clutch (See page 3-43)	• Check operation, fluid level and vehicle for fluid leakage. (See NOTE on page 3-2.)	√	√	√	√	√	
6	* Front brake (See page 3-55)	• Check operation, fluid level and vehicle for fluid leakage. (See NOTE on page 3-2.)	√	√	√	√	√	√
		• Replace brake pads.	Whenever worn to the limit					
7	* Rear brake (See page 3-56)	• Check operation, fluid level and vehicle for fluid leakage. (See NOTE on page 3-2.)	√	√	√	√	√	√
		• Replace brake pads.	Whenever worn to the limit					
8	* Brake hoses (See page 3-59)	• Check for cracks or damage.		√	√	√	√	√
		• Replace. (See NOTE on page 3-2.)	Every 4 years					
9	* Wheels (See page 3-71)	• Check runout and for damage.		√	√	√	√	
10	* Tires (See page 3-69)	• Check tread depth and for damage.		√	√	√	√	
		• Replace if necessary. • Check air pressure. • Correct if necessary.						
11	* Wheel bearings (See page 4-3)	• Check bearing for looseness or damage.		√	√	√	√	
12	* Swingarm (See page 4-89)	• Check operation and for excessive play.		√	√	√	√	
		• Lubricate with lithium-soap-based grease.	Every 50,000 km					
13	* Steering bearings (See page 3-63)	• Check bearing play and steering for roughness.	√	√	√	√	√	
		• Lubricate with lithium-soap-based grease.	Every 20,000 km					

PERIODIC MAINTENANCE AND LUBRICATION INTERVALS



No.	ITEM	CHECK OR MAINTENANCE JOB	ODOMETER READING (× 1,000 km)					ANNUAL CHECK
			1	10	20	30	40	
14 *	Chassis fasteners (See page 2-23)	• Make sure that all nuts, bolts and screws are properly tightened.		√	√	√	√	√
15	Sidestand/ centerstand (See page 3-72)	• Check operation. • Lubricate.		√	√	√	√	√
16 *	Sidestand switch (See page 8-4)	• Check operation.	√	√	√	√	√	√
17 *	Front fork (See page 3-65)	• Check operation and for oil leakage.		√	√	√	√	
18 *	Shock absorber assembly (See page 4-85)	• Check operation and shock absorber for oil leakage.		√	√	√	√	
19 *	Rear suspension relay arm and connect- ing arm pivot- ing points (See page 3-73)	• Check operation.		√	√	√	√	
		• Lubricate with lithium-soap-based grease.			√		√	
20 *	Electronic fuel injection system (See page 3-21)	• Adjust engine idling speed and synchronization.	√	√	√	√	√	√
21	Engine oil (See page 3-39)	• Change.	√	√	√	√	√	√
22	Engine oil filter cartridge (See page 3-39)	• Replace.	√		√		√	
23 *	Cooling system (See page 3-50)	• Check coolant level and vehicle for coolant leakage.		√	√	√	√	√
		• Change.	Every 3 years					
24	Final gear oil (See page 3-62)	• Check oil level and vehicle for oil leakage. • Change.	√	√	√	√	√	
25 *	Front and rear brake switches (See page 3-58)	• Check operation.	√	√	√	√	√	√
26	Moving parts and cables (See page 3-72)	• Lubricate.		√	√	√	√	√
27 *	Muffler and exhaust pipe (See page 3-49)	• Check the screw clamp for looseness.	√					
28 *	Lights, signals and switches (See page 3-82)	• Check operation. • Adjust headlight beam.	√	√	√	√	√	√

NOTE:

- The air filter needs more frequent service if you are riding in unusually wet or dusty areas.
- Hydraulic brake and clutch systems
 - After disassembling the brake or clutch master cylinders, caliper cylinders or clutch release cylinder, always change the fluid. Regularly check the brake and clutch fluid levels and fill the reservoirs as required.
 - Replace the oil seals on the inner parts of the brake or clutch master cylinders, caliper cylinders and clutch release cylinder every two years.
 - Replace the brake and clutch hoses every four years or if cracked or damaged.

EAS00039

SEATS AND FUEL TANK

SEATS

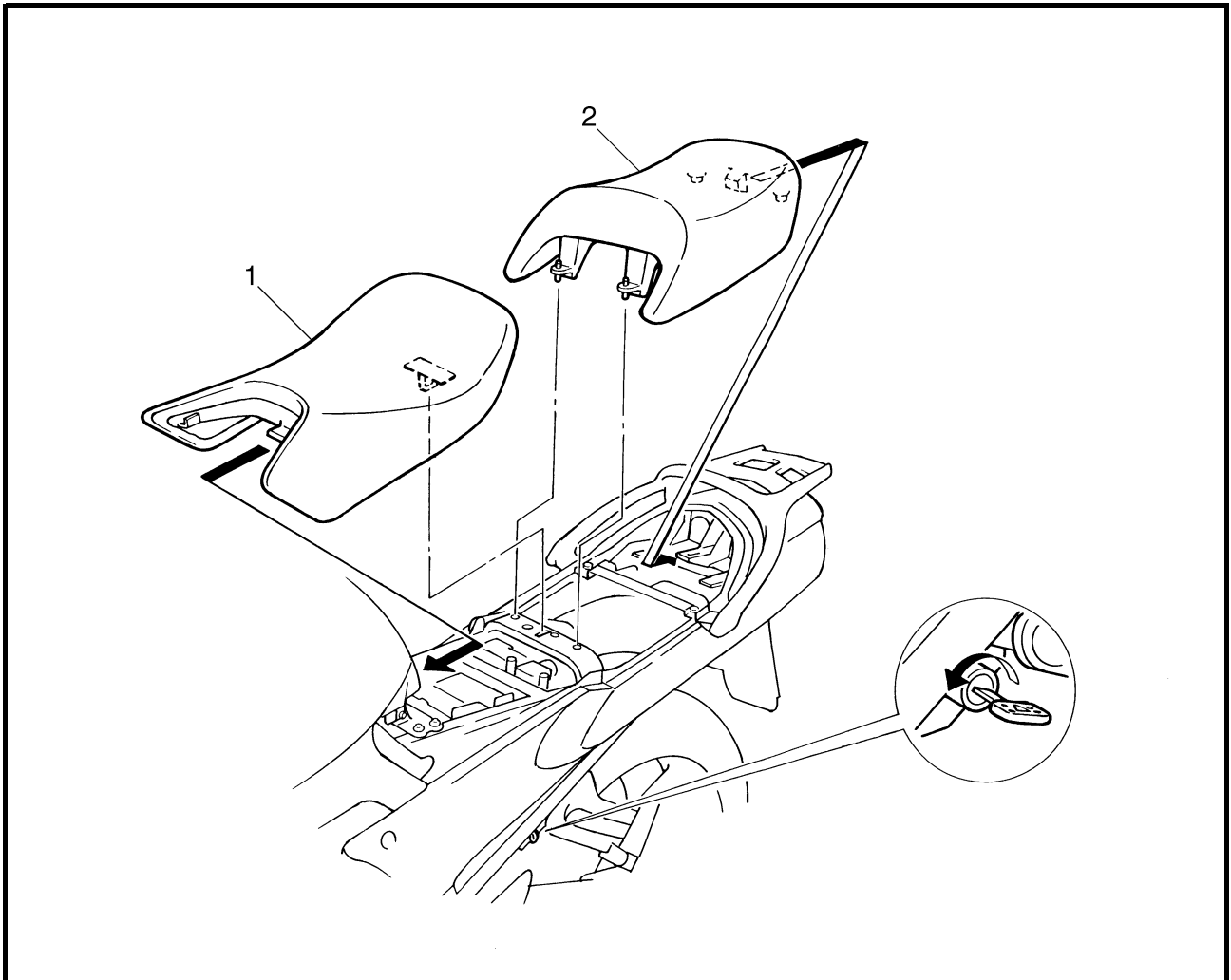

Order	Job/Part	Q'ty	Remarks
	Removing the seats		Remove the parts in the order listed.
1	Rider seat	1	
2	Passenger seat	1	
			For installation, reverse the removal procedure.

EAS00040

FUEL TANK

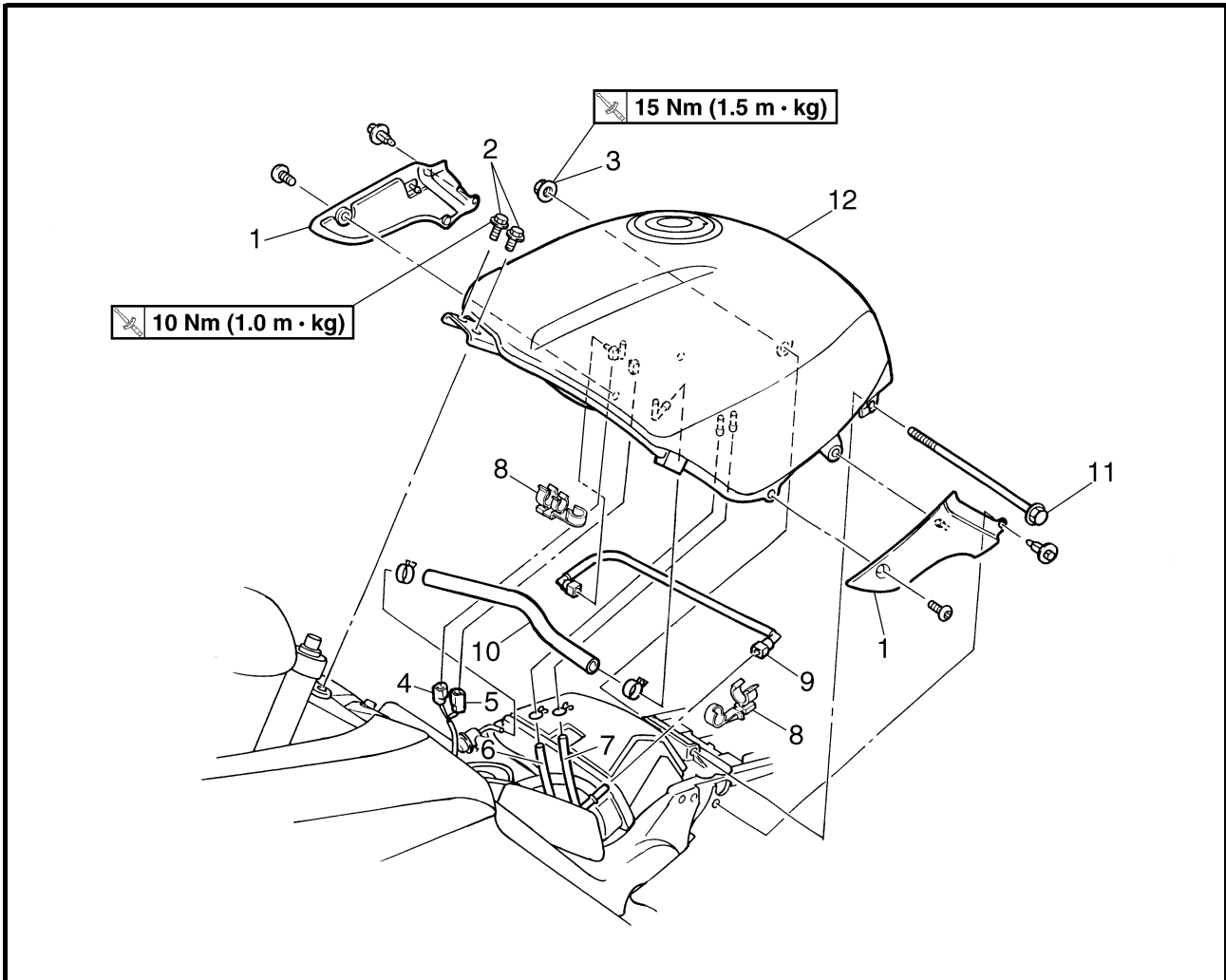

Order	Job/Part	Q'ty	Remarks
	Removing the fuel tank		Remove the parts in the order listed.
	Rider seat		
	Fuel		Drain.
1	Fuel tank side panel (left and right)	1/1	
2	Bolt	2	
3	Nut	1	
4	Fuel sender coupler	1	
5	Fuel pump coupler	1	
6	Fuel tank overflow hose	1	
7	Fuel tank breather hose	1	
8	Fuel hose holder	2	
9	Fuel hose	1	Refer to "REMOVING THE FUEL TANK" and "INSTALLING THE FUEL HOSE".
10	Fuel return hose	1	
11	Bolt	1	
12	Fuel tank	1	Refer to "REMOVING THE FUEL TANK". For installation, reverse the removal procedure.

T-BAR

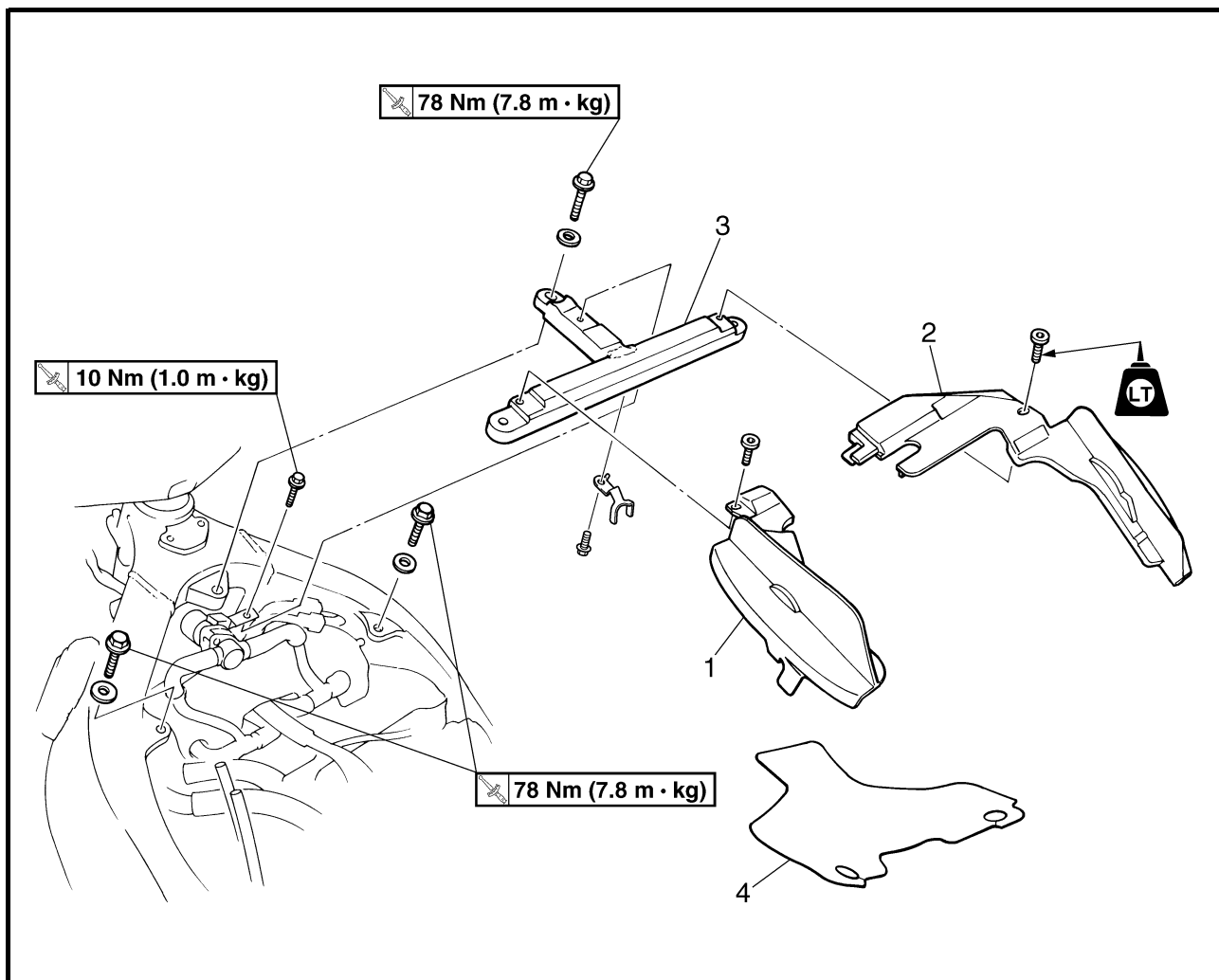

Order	Job/Part	Q'ty	Remarks
	Removing the T-bar		Remove the parts in the order listed. Refer to "SEATS AND FUEL TANK".
	Rider seat/fuel tank		
1	Left rubber cover	1	
2	Right rubber cover	1	
3	T-bar	1	
4	Rubber sheet	1	
			For installation, reverse the removal procedure.



REMOVING THE FUEL TANK

1. Extract the fuel in the fuel tank through the fuel tank cap with a pump.
2. Remove:
 - fuel return hose
 - fuel hose

CAUTION: _____

Although the fuel has been removed from the fuel tank be careful when removing the fuel hoses, since there may be fuel remaining in it.

NOTE: _____

Before removing the hoses, place a few rags in the area under where it will be removed.

3. Remove:
 - fuel tank

NOTE: _____

Do not set the fuel tank down so that the installation surface of the fuel pump is directly under the tank. Be sure to lean the fuel tank in an upright position.

REMOVING THE FUEL PUMP

1. Remove:
 - fuel pump

CAUTION: _____

- Do not drop the fuel pump or give it a strong shock.
 - Do not touch the base section of the fuel sender.
-

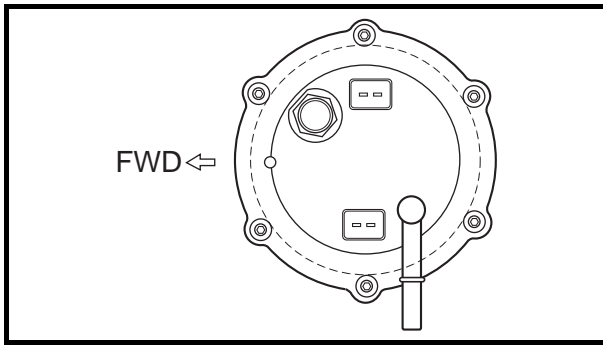
**INSTALLING THE FUEL PUMP**

1. Install:

- fuel pump

 4 Nm (0.4 m · kg)

NOTE:

- Do not damage the installation surfaces of the fuel tank when installing the fuel pump.
- Always use a new fuel pump gasket.
- Install the fuel pump as shown in the illustration.
- Tighten the fuel pump bolts in stages in a crisscross pattern and to the specified torque.

INSTALLING THE FUEL HOSE

1. Install:

- fuel hose
- fuel hose holders

CAUTION:

When installing the fuel hose, make sure that it is securely connected, and that the fuel hose holders are in the correct position, otherwise the fuel hose will not be properly installed.

INSTALLING THE T-BAR

1. Install:

- T-bar

 78 Nm (7.8 m · kg)
--

CAUTION:

Always tighten the T-bar mounting bolts to the specified torque.

EAS00043

AIR FILTER CASE

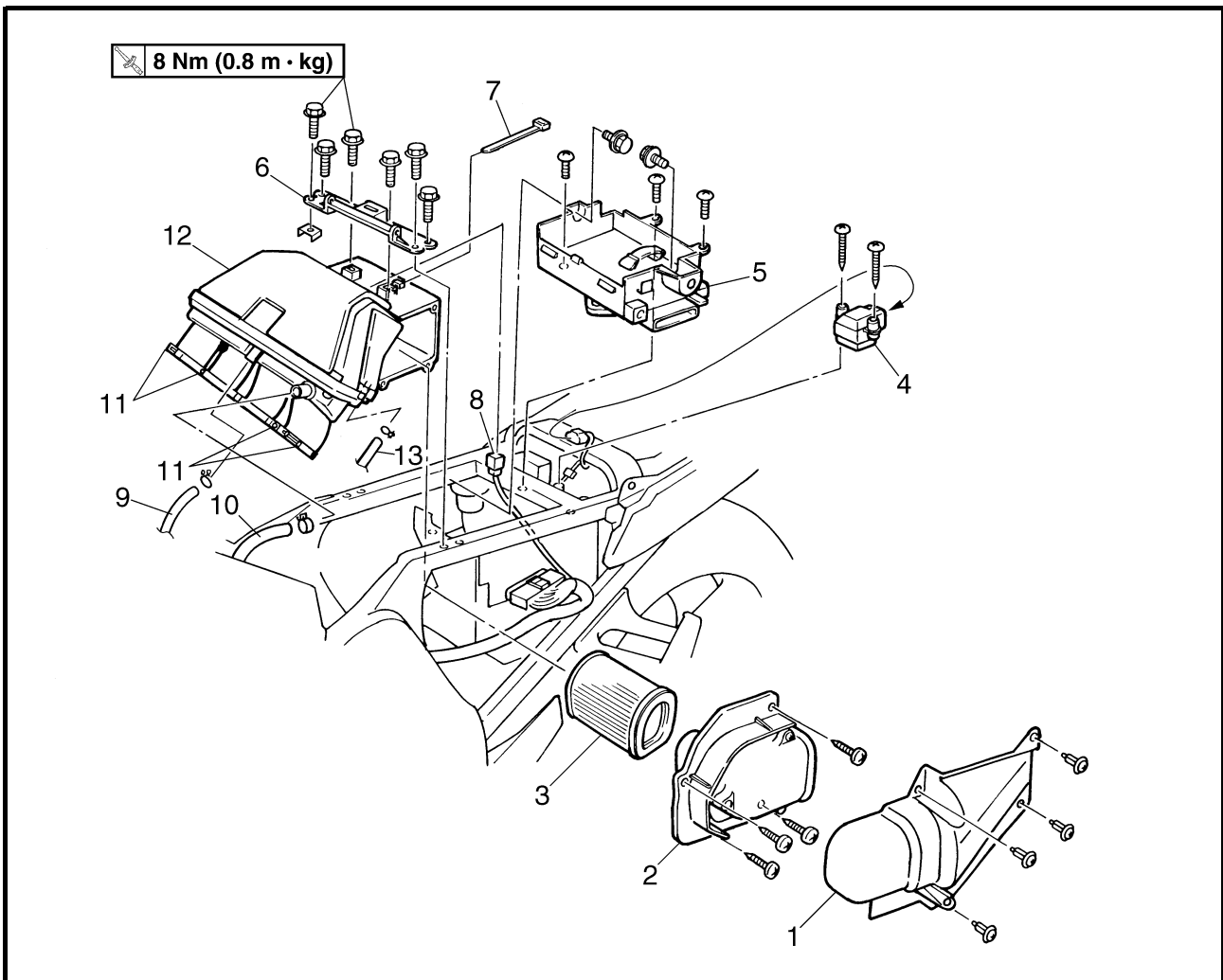

Order	Job/Part	Q'ty	Remarks
	Removing the air filter case		Remove the parts in the order listed.
	Seats/fuel tank		Refer to "SEATS AND FUEL TANK".
	Side covers (left and right)		Refer to "COWLINGS AND COVERS".
1	Air shroud	1	
2	Air filter case cover	1	
3	Air filter element	1	
4	Lean angle cut-off switch	1	
5	Tray	1	
6	Fuel tank bracket	1	
7	Plastic locking tie	1	
8	Intake air temperature sensor coupler	1	
9	Crankcase breather hose	1	Disconnect.

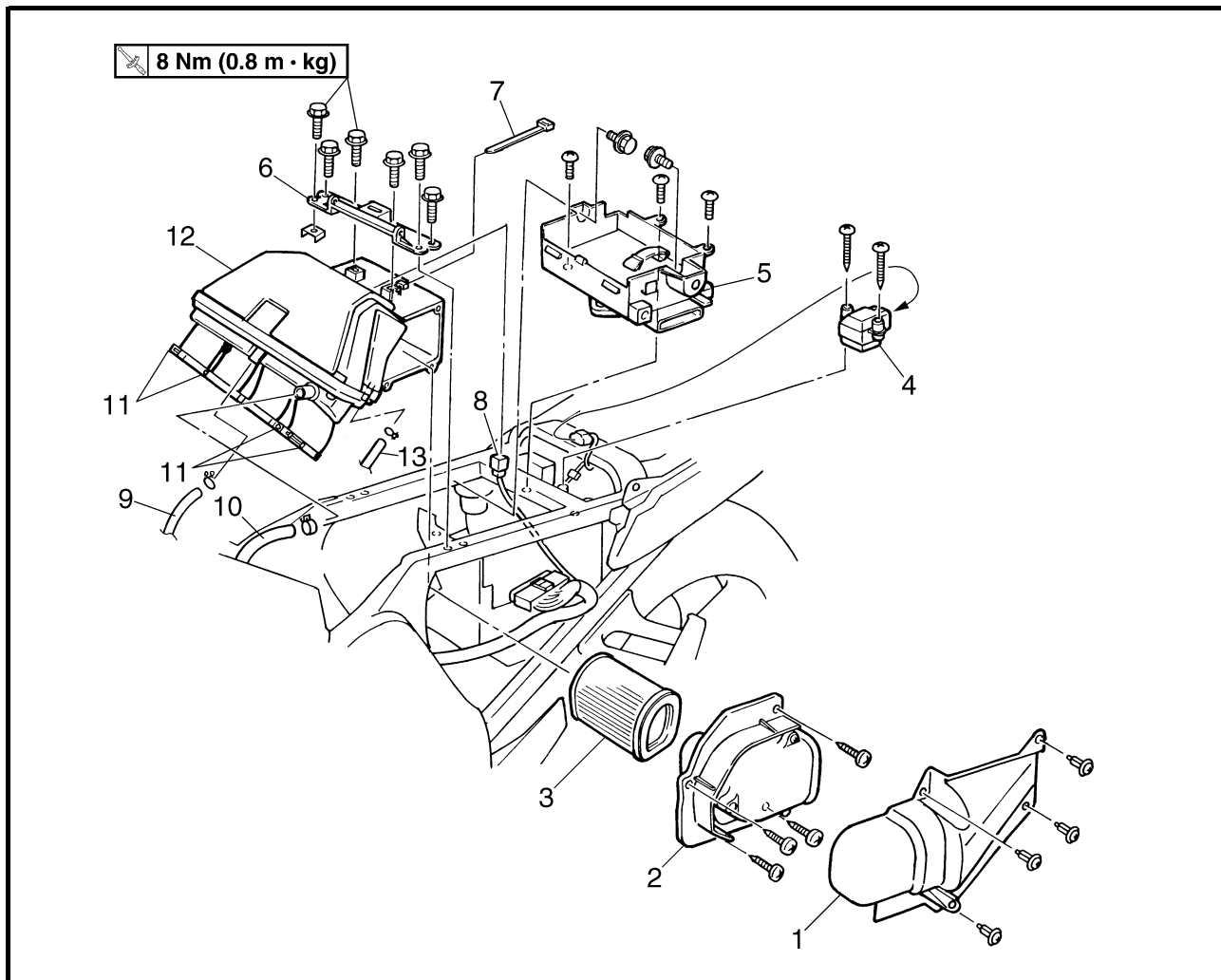

Order	Job/Part	Q'ty	Remarks
10	Air induction system hose 5	1	Disconnect.
11	Clamp screw	4	Loosen.
12	Air filter case	1	
13	Air filter case breather hose	1	
			For installation, reverse the removal procedure.

EAS00041

COWLINGS AND COVERS
COWLINGS

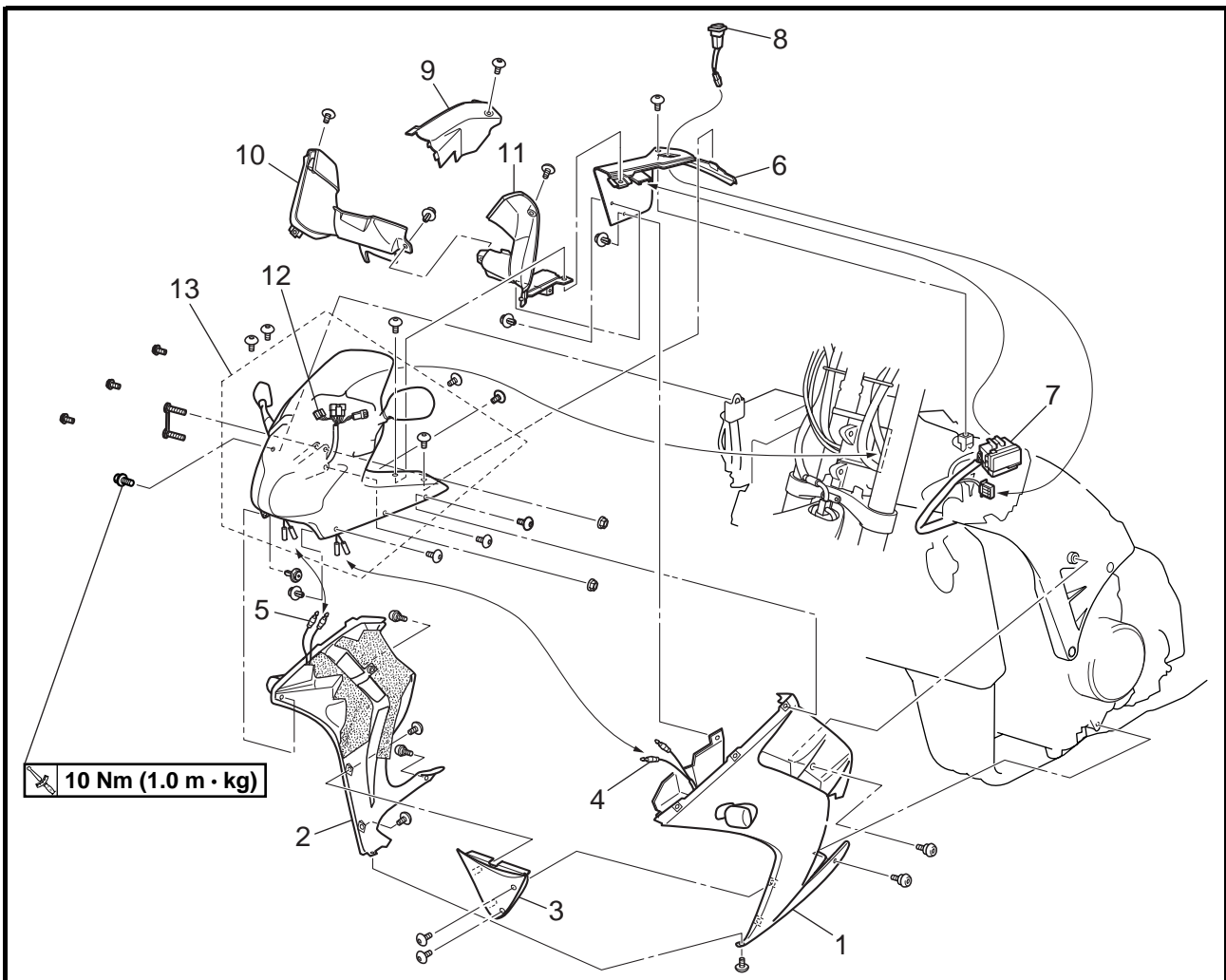

Order	Job/Part	Q'ty	Remarks
	Removing the cowlings		Remove the parts in the order listed. Refer to "SEATS AND FUEL TANK".
1	Left side cowling	1	
2	Right side cowling	1	
3	Front bottom cowling	1	
4	Front turn signal connector (left)	2	
5	Front turn signal connector (right)	2	
6	Left inner panel (front cowling)	1	
7	Fuse box	1	
8	Hazard switch	1	
9	Right inner panel (front cowling)	1	
10	Front-right inner panel (front cowling)	1	
11	Front-left inner panel (front cowling)	1	
12	Sub wire harness coupler	3	
13	Front cowling assembly	1	
			For installation, reverse the removal procedure.

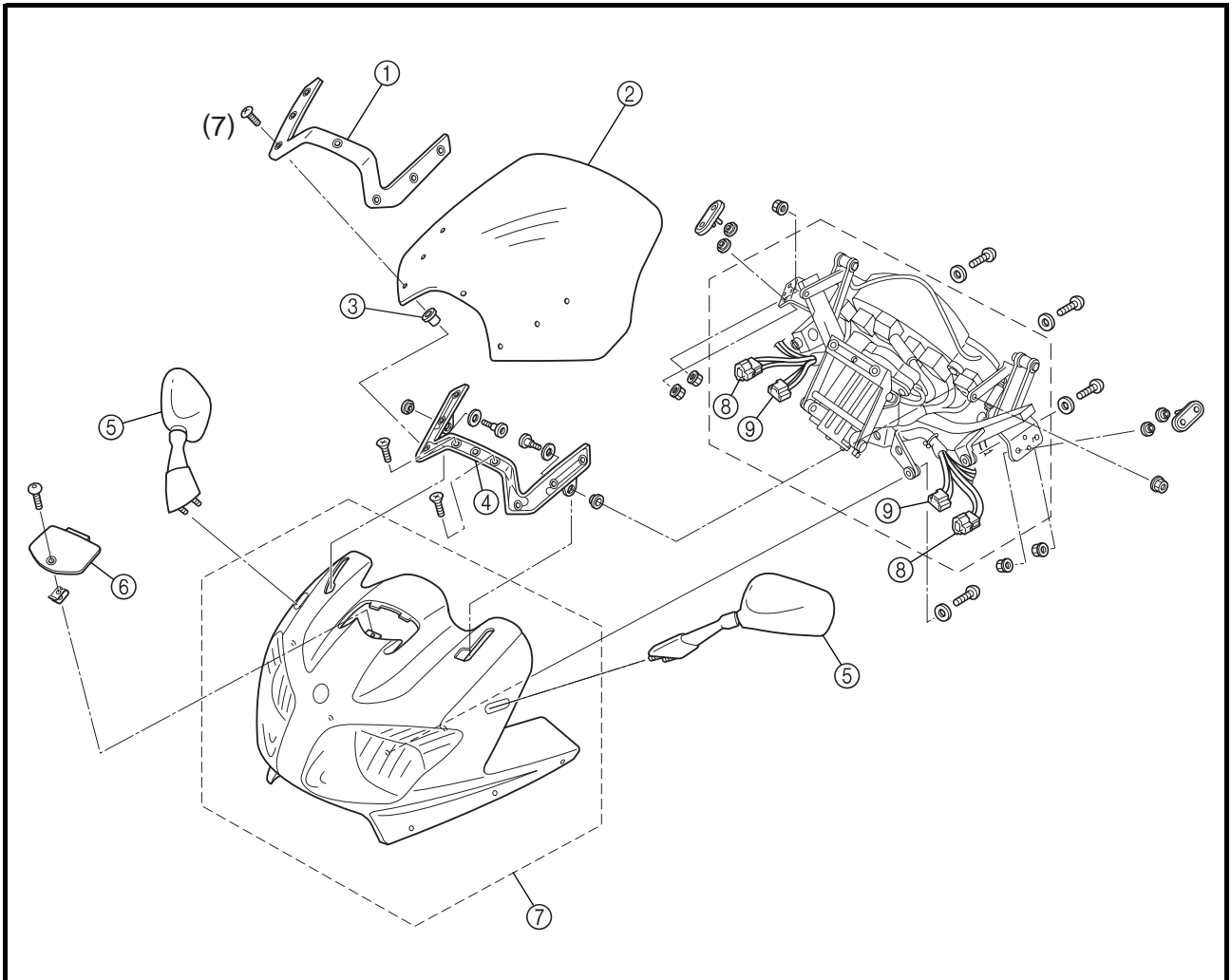

Order	Job/Part	Q'ty	Remarks
	Disassembling the front cowl assembly		Remove the parts in the order listed.
①	Windshield outer bracket	1	
②	Windshield	1	
③	Grommet	7	
④	Windshield inner bracket	1	
⑤	Rear view mirror (left and right)	2	
⑥	Panel	1	
⑦	Front cowl	1	
⑧	Auxiliary light coupler	2	
⑨	Headlight coupler	2	
			For assembly, reverse the disassembly procedure.

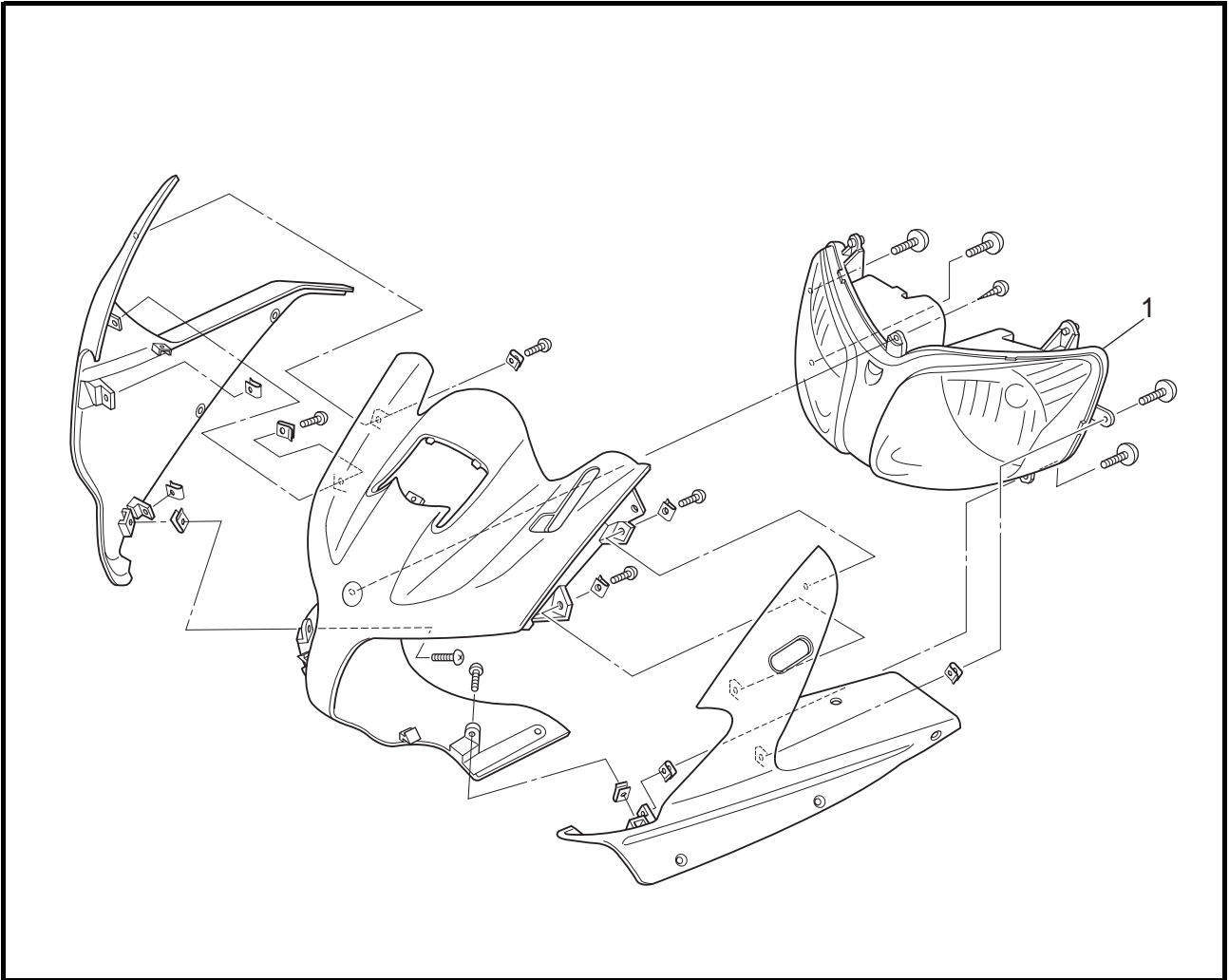

Order	Job/Part	Q'ty	Remarks
1	Removing the headlight assembly Headlight assembly	1	Remove the parts in the order listed. For installation, reverse the removal procedure.

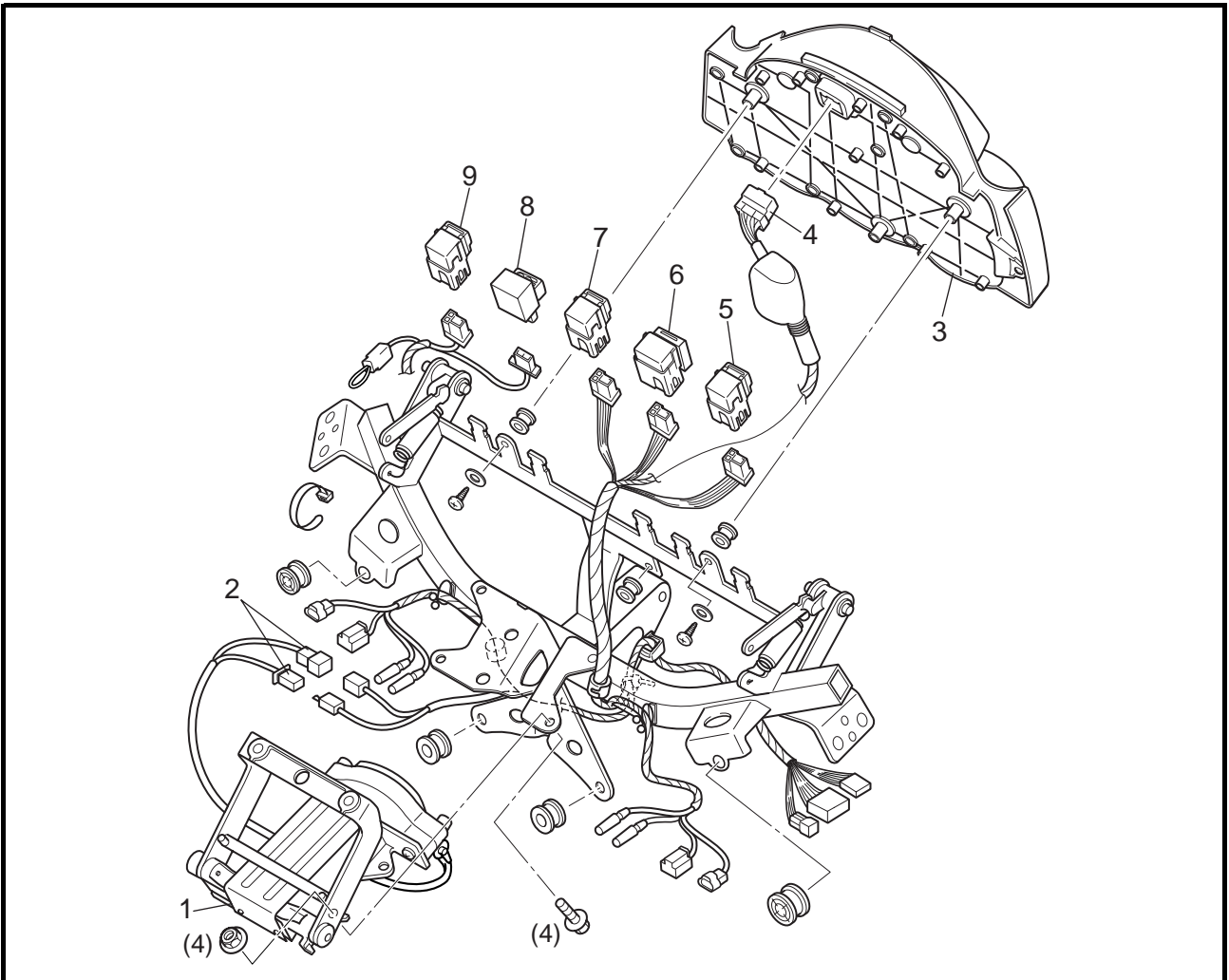

Order	Job/Part	Q'ty	Remarks
	Removing the windshield drive unit, meter assembly and relays		Remove the parts in the order listed.
1	Windshield drive unit	1	
2	Windshield drive unit coupler	2	
3	Meter assembly	1	
4	Meter assembly coupler	1	
5	Headlight relay 1	1	
6	Headlight relay 2	1	
7	Fuel injection system relay	1	
8	Turn signal relay	1	
9	Radiator fan motor relay	1	
			For installation, reverse the removal procedure.

COVERS

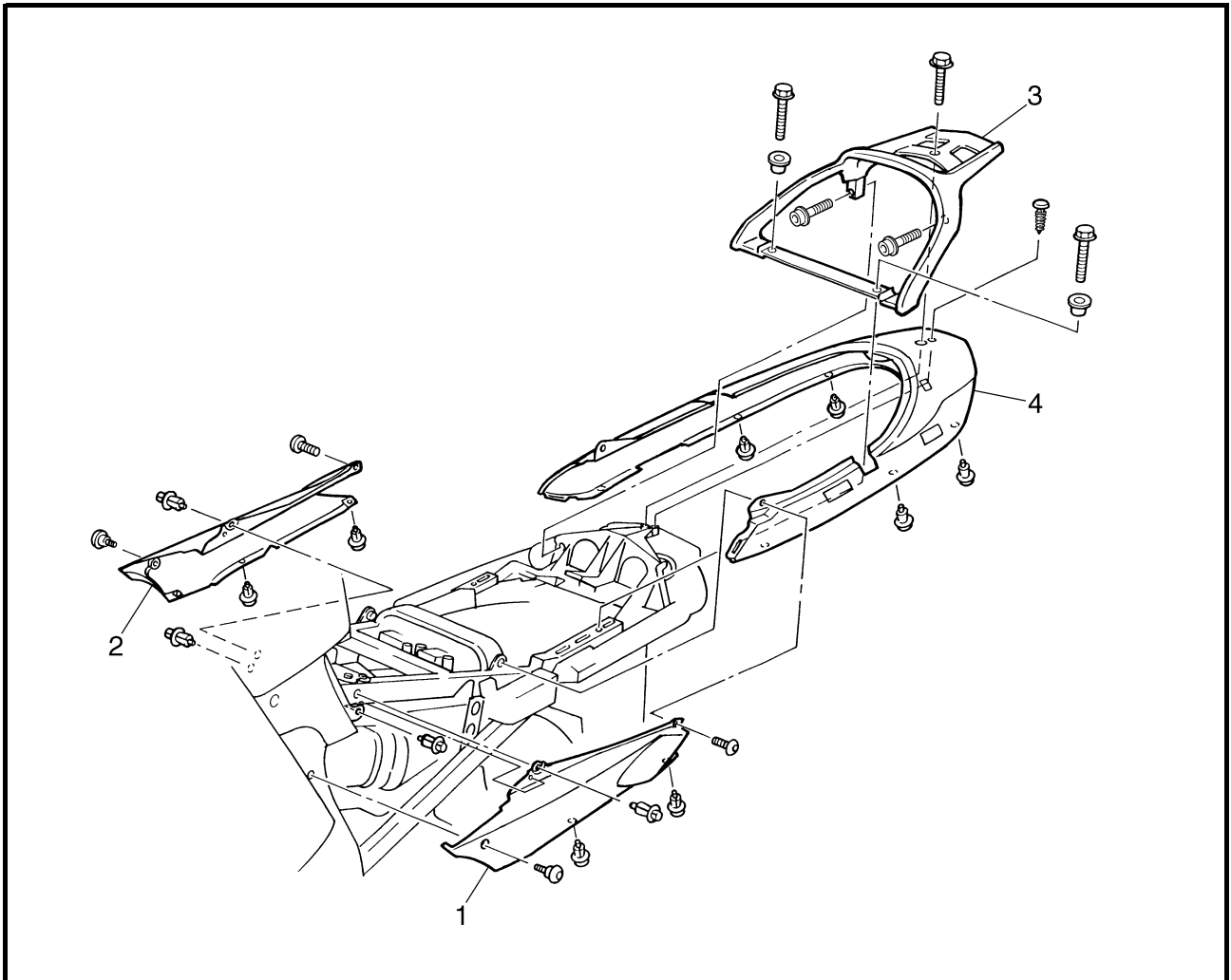

Order	Job/Part	Q'ty	Remarks
	Removing the covers		
	Seats		Remove the parts in the order listed. Refer to "SEATS AND FUEL TANK".
1	Left side cover	1	
2	Right side cover	1	
3	Rear carrier	1	
4	Rear cover	1	
			For installation, reverse the removal procedure.

EAS00045

ENGINE

ADJUSTING THE VALVE CLEARANCE

The following procedure applies to all of the valves.

NOTE:

- Valve clearance adjustment should be made on a cold engine, at room temperature.
- When the valve clearance is to be measured or adjusted, the piston must be at top dead center (TDC) on the compression stroke.

1. Remove:

- rider seat
- fuel tank
- T-bar
- rubber sheet
Refer to "SEATS AND FUEL TANK".
- side cowlings
- front cowling assembly
Refer to "COWLINGS AND COVERS".
Refer to "AIR INDUCTION SYSTEM" in chapter 7.
- thermostat assembly
Refer to "THERMOSTAT" in chapter 6.
- air cut-off valve assembly
- air induction system hoses

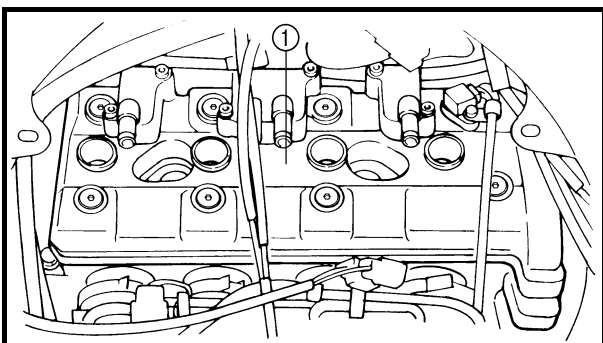

2. Remove:

- spark plugs
- cylinder head cover ①
- cylinder head cover gasket

ADJUSTING THE VALVE CLEARANCE

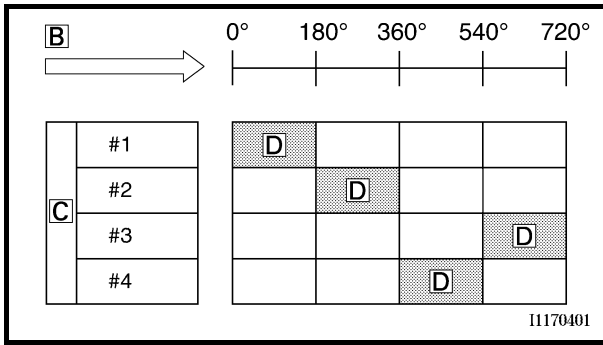

- ⓑ Degrees that the crankshaft is turned counter-clockwise
- ⓒ Cylinder
- ⓓ Combustion cycle

Cylinder #2	180°
Cylinder #4	360°
Cylinder #3	540°

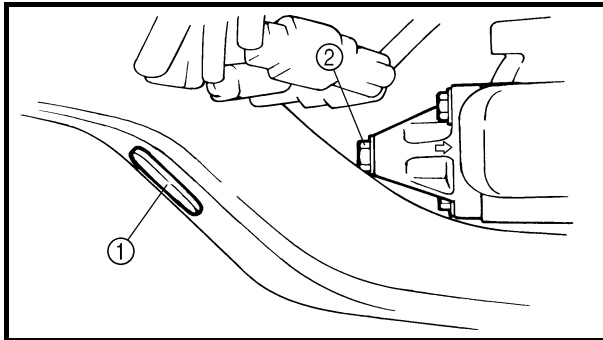

5. Remove:
- rubber plug ①
 - timing chain tensioner cap bolt ②
 - gasket

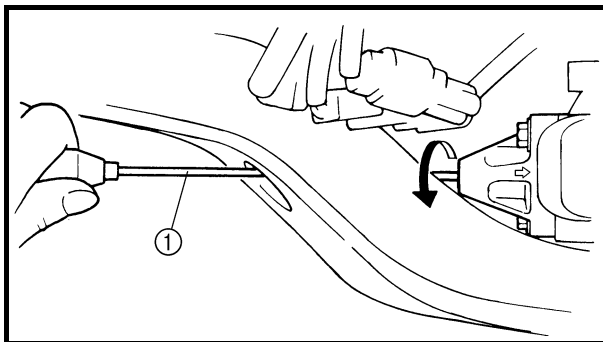

6. Turn the timing chain tensioner rod fully clockwise with a thin screwdriver ①.

NOTE: Make sure that the tensioner rod has been fully set clockwise.

7. Remove:
- intake camshaft caps
 - exhaust camshaft caps
 - timing chain (from the camshaft sprockets)
 - intake camshaft
 - exhaust camshaft

NOTE:

- Refer to "CAMSHAFTS" in chapter 5.
- When removing the timing chain and camshafts, fasten the timing chain with a wire to retrieve it if it falls into the crankcase.

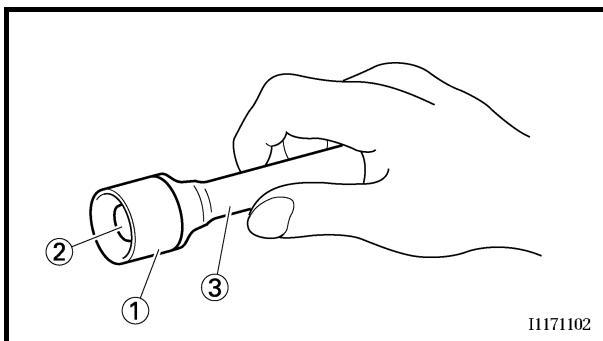

8. Adjust:
- valve clearance

- a. Remove the valve lifter ① and the valve pad ② with a valve lapper ③.

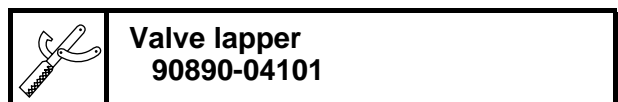

ADJUSTING THE VALVE CLEARANCE

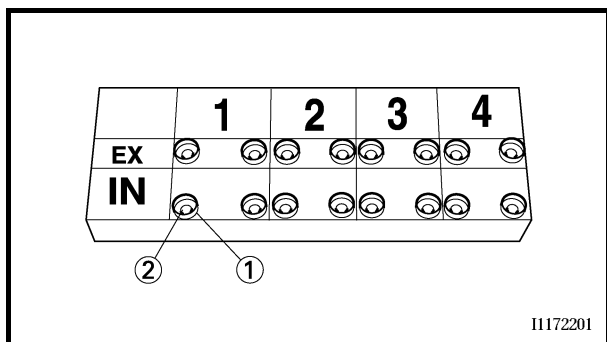

11172201

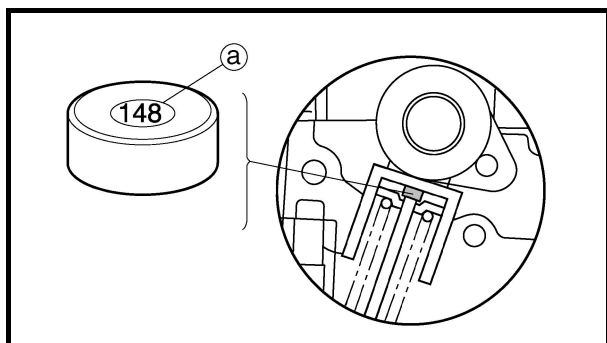

NOTE:

- Cover the timing chain opening with a rag to prevent the valve pad from falling into the crankcase.
- Make a note of the position of each valve lifter ① and valve pad ② so that they can be installed in the correct place.

- b. Select the proper valve pad from the following table.

Valve pad thickness range		Available valve pads
Nos. 120 ~ 240	1.20 ~ 2.40 mm	25 thicknesses in 0.05 mm increments

NOTE:

- The thickness ① of each valve pad is marked in hundredths of millimeters on the side that touches the valve lifter.
- Since valve pads of various sizes are originally installed, the valve pad number must be rounded in order to reach the closest equivalent to the original.

- c. Round off the original valve pad number according to the following table.

Last digit	Rounded value
0 or 2	0
5	5
8	10

EXAMPLE:

Original valve pad number = 148 (thickness = 1.48 mm)

Rounded value = 150

- d. Locate the rounded number of the original valve pad and the measured valve clearance in the valve pad selection table. The point where the column and row intersect is the new valve pad number.

NOTE:

The new valve pad number is only an approximation. The valve clearance must be measured again and the above steps should be repeated if the measurement is still incorrect.

ADJUSTING THE VALVE CLEARANCE

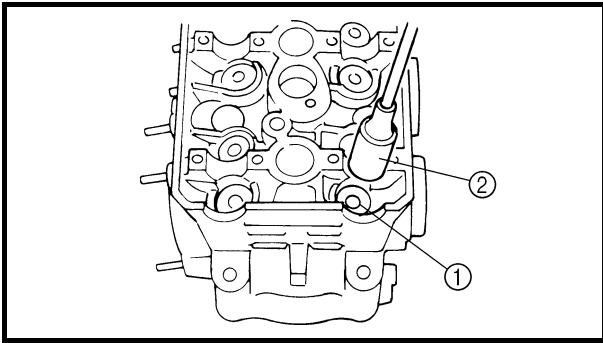

- e. Install the new valve pad ① and the valve lifter ②.

NOTE: _____

- Lubricate the valve pad with molybdenum disulfide grease.
- Lubricate the valve lifter with molybdenum disulfide oil.
- The valve lifter must turn smoothly when rotated by hand.
- Install the valve lifter and the valve pad in the correct place.

- f. Install the exhaust and intake camshafts, timing chain and camshaft caps.

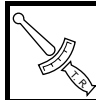

Camshaft cap bolt
10 Nm (1.0 m · kg)

NOTE: _____

- Refer to “INSTALLING THE CAMSHAFTS — CAMSHAFTS” in chapter 5.
- Lubricate the camshafts, camshaft lobes and camshaft journals.
- First, install the exhaust camshaft.
- Align the camshaft marks with the camshaft cap marks.
- Turn the crankshaft clockwise several full turns to seat the parts.

- g. Measure the valve clearance again.
- h. If the valve clearance is still out of specification, repeat all of the valve clearance adjustment steps until the specified clearance is obtained.



ADJUSTING THE VALVE CLEARANCE



INTAKE

MEASURED CLEARANCE	ORIGINAL VALVE PAD NUMBER																								
	120	125	130	135	140	145	150	155	160	165	170	175	180	185	190	195	200	205	210	215	220	225	230	235	240
0.00 ~ 0.02				120	125	130	135	140	145	150	155	160	165	170	175	180	185	190	195	200	205	210	215	220	225
0.03 ~ 0.08			120	125	130	135	140	145	150	155	160	165	170	175	180	185	190	195	200	205	210	215	220	225	230
0.09 ~ 0.14		120	125	130	135	140	145	150	155	160	165	170	175	180	185	190	195	200	205	210	215	220	225	230	235
0.15 ~ 0.22																									
	STANDARD CLEARANCE																								
0.23 ~ 0.28	125	130	135	140	145	150	155	160	165	170	175	180	185	190	195	200	205	210	215	220	225	230	235	240	
0.29 ~ 0.34	130	135	140	145	150	155	160	165	170	175	180	185	190	195	200	205	210	215	220	225	230	235	240		
0.35 ~ 0.40	135	140	145	150	155	160	165	170	175	180	185	190	195	200	205	210	215	220	225	230	235	240			
0.41 ~ 0.46	140	145	150	155	160	165	170	175	180	185	190	195	200	205	210	215	220	225	230	235	240				
0.47 ~ 0.52	145	150	155	160	165	170	175	180	185	190	195	200	205	210	215	220	225	230	235	240					
0.53 ~ 0.58	150	155	160	165	170	175	180	185	190	195	200	205	210	215	220	225	230	235	240						
0.59 ~ 0.64	155	160	165	170	175	180	185	190	195	200	205	210	215	220	225	230	235	240							
0.65 ~ 0.70	160	165	170	175	180	185	190	195	200	205	210	215	220	225	230	235	240								
0.71 ~ 0.76	165	170	175	180	185	190	195	200	205	210	215	220	225	230	235	240									
0.77 ~ 0.82	170	175	180	185	190	195	200	205	210	215	220	225	230	235	240										
0.83 ~ 0.88	175	180	185	190	195	200	205	210	215	220	225	230	235	240											
0.89 ~ 0.94	180	185	190	195	200	205	210	215	220	225	230	235	240												
0.95 ~ 1.00	185	190	195	200	205	210	215	220	225	230	235	240													
1.01 ~ 1.06	190	195	200	205	210	215	220	225	230	235	240														
1.07 ~ 1.12	195	200	205	210	215	220	225	230	235	240															
1.13 ~ 1.18	200	205	210	215	220	225	230	235	240																
1.19 ~ 1.24	205	210	215	220	225	230	235	240																	
1.25 ~ 1.30	210	215	220	225	230	235	240																		
1.31 ~ 1.36	215	220	225	230	235	240																			
1.37 ~ 1.42	220	225	230	235	240																				
1.43 ~ 1.48	225	230	235	240																					
1.49 ~ 1.54	230	235	240																						
1.55 ~ 1.60	235	240																							
1.61 ~ 1.66	240																								

VALVE CLEARANCE (cold):
 0.15 ~ 0.22 mm
 Example: Installed is pad 150
 Measured clearance is 0.30 mm
 Replace pad 150 with pad 160
 Pad number: (example)
 Pad No. 150 = 1.50 mm
 Pad No. 160 = 1.60 mm
 Always install pad with number down.

EXHAUST

MEASURED CLEARANCE	ORIGINAL VALVE PAD NUMBER																								
	120	125	130	135	140	145	150	155	160	165	170	175	180	185	190	195	200	205	210	215	220	225	230	235	240
0.00 ~ 0.05				120	125	130	135	140	145	150	155	160	165	170	175	180	185	190	195	200	205	210	215	220	225
0.06 ~ 0.11			120	125	130	135	140	145	150	155	160	165	170	175	180	185	190	195	200	205	210	215	220	225	230
0.12 ~ 0.17		120	125	130	135	140	145	150	155	160	165	170	175	180	185	190	195	200	205	210	215	220	225	230	235
0.18 ~ 0.25																									
	STANDARD CLEARANCE																								
0.26 ~ 0.31	125	130	135	140	145	150	155	160	165	170	175	180	185	190	195	200	205	210	215	220	225	230	235	240	
0.32 ~ 0.37	130	135	140	145	150	155	160	165	170	175	180	185	190	195	200	205	210	215	220	225	230	235	240		
0.38 ~ 0.43	135	140	145	150	155	160	165	170	175	180	185	190	195	200	205	210	215	220	225	230	235	240			
0.44 ~ 0.49	140	145	150	155	160	165	170	175	180	185	190	195	200	205	210	215	220	225	230	235	240				
0.50 ~ 0.55	145	150	155	160	165	170	175	180	185	190	195	200	205	210	215	220	225	230	235	240					
0.56 ~ 0.61	150	155	160	165	170	175	180	185	190	195	200	205	210	215	220	225	230	235	240						
0.62 ~ 0.67	155	160	165	170	175	180	185	190	195	200	205	210	215	220	225	230	235	240							
0.68 ~ 0.73	160	165	170	175	180	185	190	195	200	205	210	215	220	225	230	235	240								
0.74 ~ 0.79	165	170	175	180	185	190	195	200	205	210	215	220	225	230	235	240									
0.80 ~ 0.85	170	175	180	185	190	195	200	205	210	215	220	225	230	235	240										
0.86 ~ 0.91	175	180	185	190	195	200	205	210	215	220	225	230	235	240											
0.92 ~ 0.97	180	185	190	195	200	205	210	215	220	225	230	235	240												
0.98 ~ 1.03	185	190	195	200	205	210	215	220	225	230	235	240													
1.04 ~ 1.09	190	195	200	205	210	215	220	225	230	235	240														
1.10 ~ 1.15	195	200	205	210	215	220	225	230	235	240															
1.16 ~ 1.21	200	205	210	215	220	225	230	235	240																
1.22 ~ 1.27	205	210	215	220	225	230	235	240																	
1.28 ~ 1.33	210	215	220	225	230	235	240																		
1.34 ~ 1.39	215	220	225	230	235	240																			
1.40 ~ 1.45	220	225	230	235	240																				
1.46 ~ 1.51	225	230	235	240																					
1.52 ~ 1.57	230	235	240																						
1.58 ~ 1.63	235	240																							
1.64 ~ 1.69	240																								

VALVE CLEARANCE (cold):
 0.18 ~ 0.25 mm
 Example: Installed is pad 175
 Measured clearance is 0.32 mm
 Replace pad 175 with pad 185
 Pad number: (example)
 Pad No. 175 = 1.75 mm
 Pad No. 185 = 1.85 mm
 Always install pad with number down.

ADJUSTING THE VALVE CLEARANCE/ SYNCHRONIZING THE THROTTLE BODIES



9. Install:
- all removed parts

NOTE: _____

For installation, reverse the removal procedure.

EAS00050

SYNCHRONIZING THE THROTTLE BODIES

NOTE: _____

Prior to synchronizing the throttle bodies, the valve clearance and the engine idling speed should be properly adjusted and the ignition timing should be checked.

1. Stand the motorcycle on a level surface.

NOTE: _____

Place the motorcycle on a suitable stand.

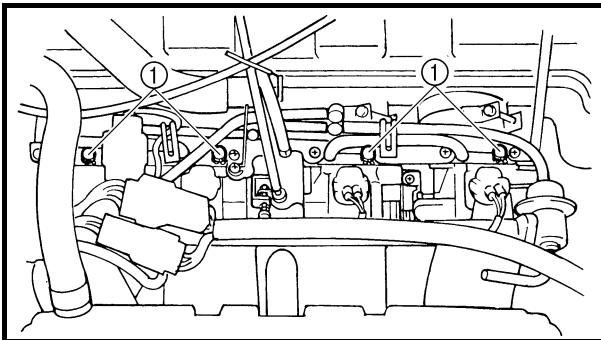

2. Remove:

- rider seat
- fuel tank
- T-bar

Refer to "SEATS AND FUEL TANK".

3. Remove:

- caps ①

4. Install:

- vacuum gauge
(onto the pipes)
- engine tachometer
(onto the spark plug lead of cylinder #1)



Vacuum gauge

90890-03094

Engine tachometer

90890-06760

5. Install:

- fuel tank

Refer to "SEATS AND FUEL TANK".

6. Start the engine and let it warm up for several minutes.

SYNCHRONIZING THE THROTTLE BODIES/CHECKING AND ADJUSTING THE EXHAUST GAS AT IDLE



11. Adjust:

- throttle cable free play

Refer to “ADJUSTING THE THROTTLE CABLE FREE PLAY”.



Throttle cable free play (at the flange of the throttle grip)
3 ~ 5 mm

12. Remove:

- engine tachometer
- vacuum gauge

13. Remove:

- fuel tank

14. Install:

- T-bar

15. Install:

- fuel tank
- rider seat

Refer to “SEATS AND FUEL TANK”.

Note: On North American models the ECU jumper must be relocated prior to performing the following procedure. Please refer to <http://www.micapeak.com/bike/FJR1300/howto/jumper.html>

CHECKING AND ADJUSTING THE EXHAUST GAS AT IDLE

(Measuring the exhaust gas at idle [when the air induction system does not operate])

1. Stand the motorcycle on a level surface.

NOTE:

- Place the motorcycle on a suitable stand.
- Make sure the motorcycle is upright.

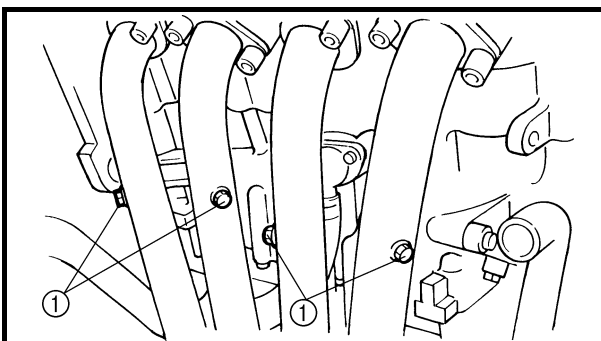

2. Remove:

- rider seat
- fuel tank
- T-bar

Refer to “SEATS AND FUEL TANK”.

- side cowlings
Refer to “COWLINGS AND COVERS”.
- exhaust pipe bolts ①

CHECKING AND ADJUSTING THE EXHAUST GAS AT IDLE

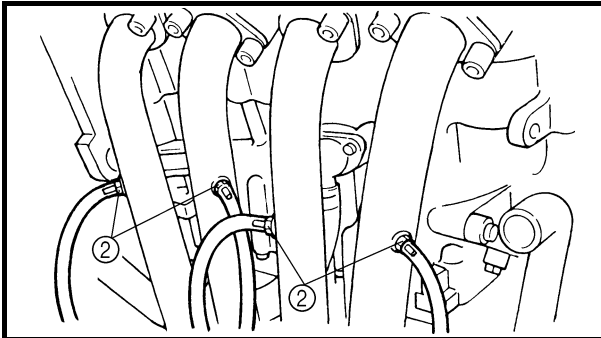
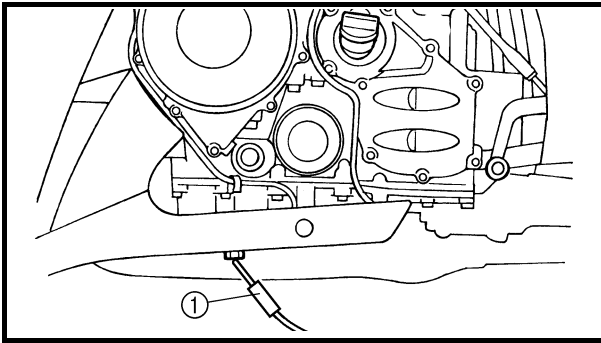

3. Install:

- pocket tester ①
(onto the engine oil drain bolt)
- engine tachometer
(onto the spark plug lead of cylinder #1)
- exhaust attachment ②
(onto the exhaust pipe)



Pocket tester
90890-03132
Engine tachometer
90890-06760
Exhaust attachment
90890-03134

4. Install:

- fuel tank
Refer to "SEATS AND FUEL TANK".

5. Start the engine and warm it up until the specified oil temperature is reached.



Oil temperature
80 ~ 90 °C

6. Measure:

- engine idling speed
Out of specification → Adjust.
Refer to "ADJUSTING THE ENGINE IDLING SPEED".



Engine idling speed
1,000 ~ 1,100 r/min

Note: Not all bikes are equipped with the exhaust ports on the headers. Refer to <http://www.micapeak.com/bike/FJR1300/howto/rivnut.html> for directions on how to add them. □

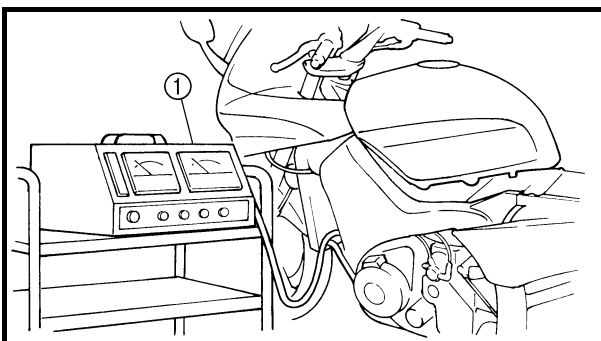

7. Install:

- CO/HC tester ①
(onto the exhaust attachment)

CHECKING AND ADJUSTING THE EXHAUST GAS AT IDLE/ADJUSTING THE EXHAUST GAS VOLUME



8. Measure:
- carbon monoxide density
Out of specification → Adjust.
Within specification → Measure the exhaust gas when induction system is operating.

	Carbon monoxide density (when air induction system is not operating)
	3.0 ~ 4.0%
	Hydrocarbon density (when air induction system is not operating)

ADJUSTING THE EXHAUST GAS VOLUME

NOTE: _____

Be sure to set the carbon monoxide density to standard, and then adjust the exhaust gas.



Setting steps

NOTE: _____

If the battery is not fully charged errors one to four will be indicated on the display.

- a. "CO" and "DIAG" modes
Push the "SELECT" button and the "RESET" button together, and then set the main switch to "ON".

NOTE: _____

Be sure to push the buttons for more than eight seconds after setting the main switch to "ON".

- All segments, except the clock and "TRIP", will start flashing.
- "DIAG" will be indicated on the display.



- b. To switch to the "CO" adjusting mode
 - 1) Push the "SELECT" button to switch the display between the "CO" adjusting mode and the "DIAG" mode.
 - 2) Push the "SELECT" button and "RESET" button together for more than two seconds to set the desired mode.
- c. To select the cylinder to be adjusted
 - Push the "SELECT" button or the "RESET" button to select the cylinder.

NOTE: _____

The number of the cylinder to be adjusted will be indicated on the display.

- Push the "RESET" button to scroll down the cylinder numbers.
 - Push the "SELECT" button to scroll up the cylinder numbers.
 - Push the "SELECT" button and the "RESET" button together for more than two seconds to set the cylinder.
- d. To adjust the carbon monoxide exhaust gas volume
 - After selecting the cylinder, adjust the exhaust gas volume by pushing the "SELECT" button or the "RESET" button.

NOTE: _____

The exhaust gas volume will be indicated on the display.

- Push the "RESET" button to increase the volume.
 - Push the "SELECT" button to decrease the volume.
 - Release the button to set the volume.
 - Push the "SELECT" button and the "RESET" button together to return to the selected cylinder.
- e. To deactivate the mode set the main switch "OFF".



CHECKING THE EXHAUST GAS AT IDLE

(Measuring the exhaust gas at idle [when air induction system is operating])

1. Stand the motorcycle on a level surface.

NOTE: _____

- Place the motorcycle on a suitable stand.
- Make sure the motorcycle is upright.

2. Remove:

- rider seat
- fuel tank
- T-bar

Refer to "SEATS AND FUEL TANK".

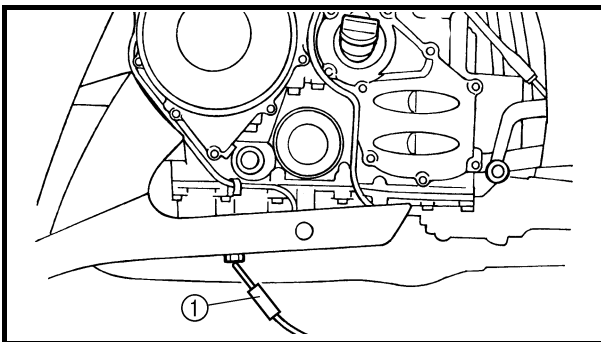

3. Install:

- pocket tester ①
(onto the engine oil drain bolt)
- engine tachometer
(onto the spark plug lead of cylinder #1)



Pocket tester
90890-03132
Engine tachometer
90890-06760

4. Install:

- fuel tank
Refer to "SEATS AND FUEL TANK".

5. Start the engine and warm it up until the specified oil temperature is reached.



Oil temperature
80 ~ 90 °C

6. Measure:

- engine idling speed
Out of specification → Adjust.
Refer to "ADJUSTING THE ENGINE IDLING SPEED".



Engine idling speed
1,000 ~ 1,100 r/min

CHECKING THE EXHAUST GAS AT IDLE/ ADJUSTING THE ENGINE IDLING SPEED

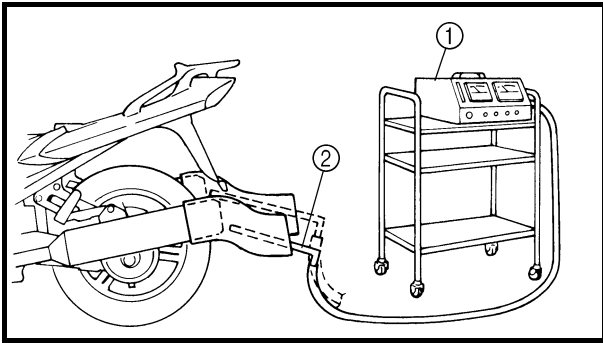

7. Install:

- carbon monoxide and hydrocarbon tester ①
- sampling probe ②

NOTE:

- Since it is necessary to insert the sampling probe 600 mm into the exhaust pipe, be sure to use a heat-resistant rubber tube as shown in the illustration.
- Be sure to set the heat-resistant rubber tube so that exhaust gas does not leak out.
- Before using the carbon monoxide and hydrocarbon tester, be sure to read the user's manual.

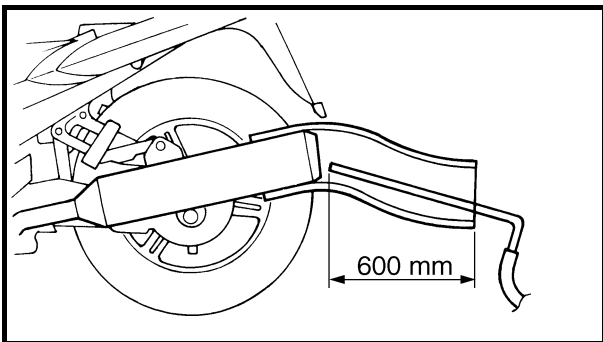

8. Measure:

- carbon monoxide density
- hydrocarbon density



**Carbon monoxide density (when
air induction system is operating)
Below 1%
(Reference value)**

Out of specification → Check air induction system.

Refer to "AIR INDUCTION SYSTEM" in chapter 7.

EAS00052

ADJUSTING THE ENGINE IDLING SPEED

NOTE:

Prior to adjusting the engine idling speed, the throttle bodies synchronization should be adjusted properly, the air filter element should be clean, and the engine should have adequate compression.

ADJUSTING THE ENGINE IDLING SPEED/ ADJUSTING THE THROTTLE CABLE FREE PLAY



7. Adjust:

- throttle cable free play

Refer to "ADJUSTING THE THROTTLE CABLE FREE PLAY".



Throttle cable free play (at the flange of the throttle grip)
3 ~ 5 mm

8. Install:

- fuel tank front mounting bolts
- fuel tank side panels (left and right)

Refer to "SEATS AND FUEL TANK".

EAS00055

ADJUSTING THE THROTTLE CABLE FREE PLAY

NOTE:

Prior to adjusting the throttle cable free play, the engine idling speed and carburetor synchronization should be adjusted properly.

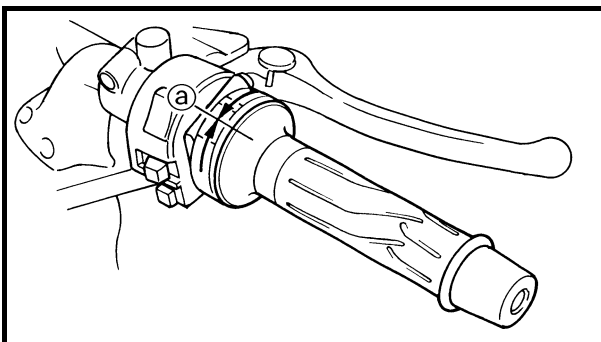

1. Check:

- throttle cable free play ①

Out of specification → Adjust.



Throttle cable free play (at the flange of the throttle grip)
3 ~ 5 mm

2. Remove:

- rider seat
- fuel tank

Refer to "SEATS AND FUEL TANK".

⚠ WARNING

After adjusting the throttle cable free play, start the engine and turn the handlebar to the right and to the left to ensure that this does not cause the engine idling speed to change.



4. Install:
- fuel tank
 - rider seat
- Refer to “SEATS AND FUEL TANK”.

EAS00059

CHECKING THE SPARK PLUGS

The following procedure applies to all of the spark plugs.

1. Remove:
- rider seat
 - fuel tank
 - T-bar
- Refer to “SEATS AND FUEL TANK”.
2. Disconnect:
- spark plug cap
3. Remove:
- spark plug

CAUTION:

Before removing the spark plugs, blow away any dirt accumulated in the spark plug wells with compressed air to prevent it from falling into the cylinders.

4. Check:
- spark plug type
- Incorrect → Change.

	Spark plug type (manufacturer) CR8E (NGK) U24ESR-N (DENSO)
---	---

CHECKING THE SPARK PLUGS/ CHECKING THE IGNITION TIMING

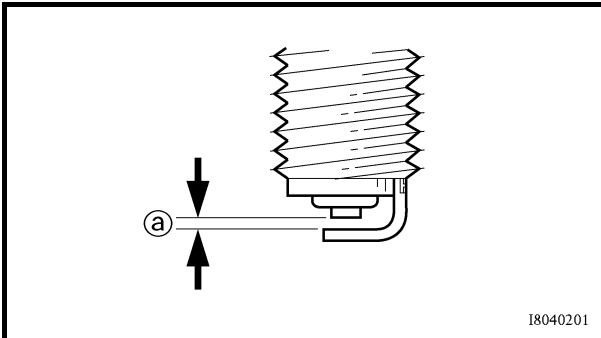
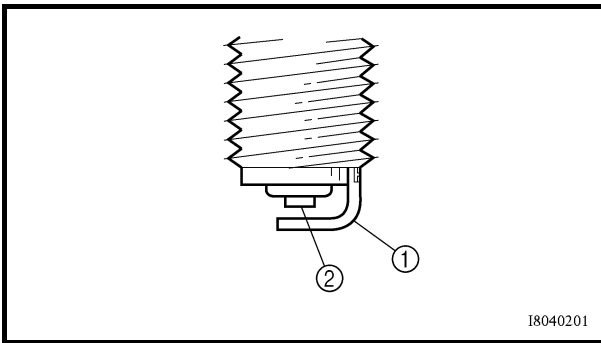

5. Check:

- electrodes ①
Damage/wear → Replace the spark plug.
- insulator ②
Abnormal color → Replace the spark plug.
Normal color is medium-to-light tan.

6. Clean:

- spark plug
(with a spark plug cleaner or wire brush)

7. Measure:

- spark plug gap ③
(with a wire gauge)
Out of specification → Regap.

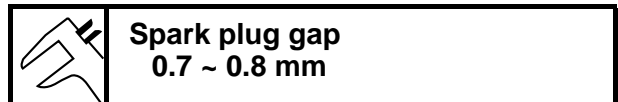

8. Install:

- spark plug

13 Nm (1.3 m · kg)

NOTE:

Before installing the spark plug, clean the spark plug and gasket surface.

9. Connect:

- spark plug cap

10. Install:

- T-bar
- fuel tank
- rider seat

Refer to “SEATS AND FUEL TANK”.

EAS00061

CHECKING THE IGNITION TIMING

NOTE:

Prior to checking the ignition timing, check the wiring connections of the entire ignition system. Make sure all connections are tight and free of corrosion.



5. Remove:
 - fuel tank
 - engine tachometer
 - timing light
6. Install:
 - timing mark accessing screw
Refer to "COWLINGS AND COVERS".
 - T-bar
 - fuel tank
 - rider seat
Refer to "SEATS AND FUEL TANK".

EAS00065

MEASURING THE COMPRESSION PRESSURE

The following procedure applies to all of the cylinders.

NOTE: _____
Insufficient compression pressure will result in a loss of performance.

1. Measure:
 - valve clearance
Out of specification → Adjust.
Refer to "ADJUSTING THE VALVE CLEARANCE".
2. Start the engine, warm it up for several minutes, and then turn it off.
3. Remove:
 - rider seat
 - fuel tank
 - T-bar
Refer to "SEATS AND FUEL TANK".
4. Disconnect:
 - spark plug cap
5. Remove:
 - spark plug

CAUTION: _____

Before removing the spark plugs, use compressed air to blow away any dirt accumulated in the spark plug wells to prevent it from falling into the cylinders.

Refer to the following table.

Compression pressure (with oil applied into the cylinder)	
Reading	Diagnosis
Higher than without oil	Piston wear or damage → Repair.
Same as without oil	Piston ring(s), valves, cylinder head gasket or piston possibly defective → Repair.



9. Remove:
- fuel tank

10. Install:
- spark plug

 **13 Nm (1.3 m · kg)**

11. Connect:
- Spark plug cap
12. Install:
- T-bar
 - fuel tank
 - rider seat

EAS00069

CHECKING THE ENGINE OIL LEVEL

1. Stand the motorcycle on a level surface.

NOTE: _____

- Place the motorcycle on a suitable stand.
- Make sure the motorcycle is upright.

2. Start the engine, warm it up for several minutes, and then turn it off.

CHECKING THE ENGINE OIL LEVEL

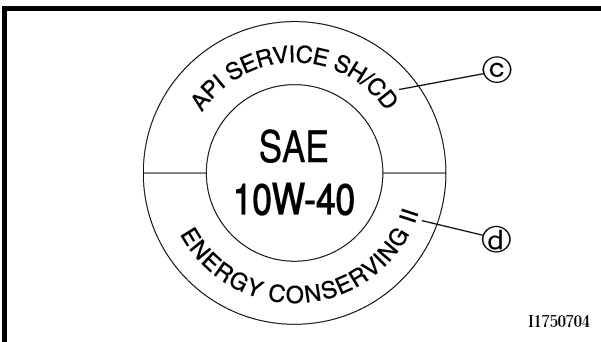
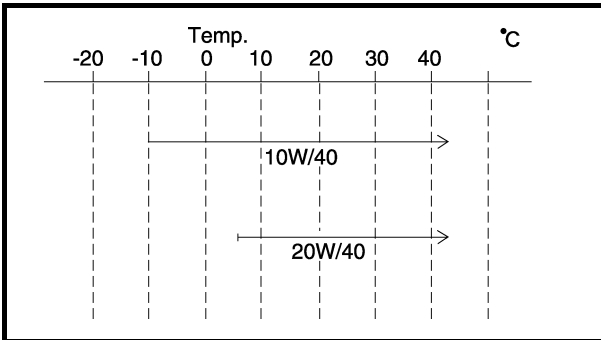
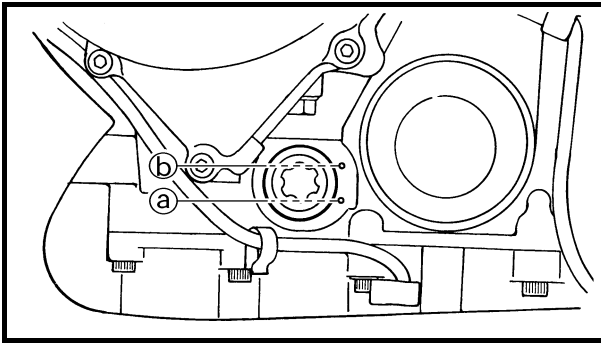

3. Check:

- engine oil level

The engine oil level should be between the minimum level mark (a) and maximum level mark (b).

Below the minimum level mark → Add the recommended engine oil to the proper level.



Recommended oil

Refer to the chart for the engine oil grade which is best suited for certain atmospheric temperatures.

API standard
SE or higher grade
ACEA standard
G4 or G5

CAUTION:

- Engine oil also lubricates the clutch and the wrong oil types or additives could cause clutch slippage. Therefore, do not add any chemical additives or use engine oils with a grade of CD (c) or higher and do not use oils labeled “ENERGY CONSERVING II” (d) or higher.
- Do not allow foreign materials to enter the crankcase.

NOTE:

Before checking the engine oil level, wait a few minutes until the oil has settled.

4. Start the engine, warm it up for several minutes, and then turn it off.
5. Check the engine oil level again.

NOTE:

Before checking the engine oil level, wait a few minutes until the oil has settled.

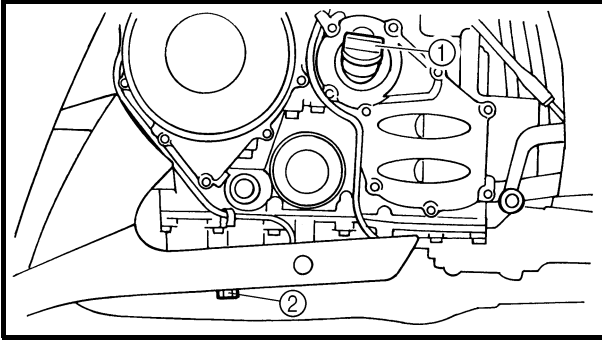

EAS00073

CHANGING THE ENGINE OIL

1. Start the engine, warm it up for several minutes, and then turn it off.
2. Place a container under the engine oil drain bolt.
3. Remove:
 - engine oil filler cap ①
 - engine oil drain bolt ② (along with the gasket)
4. Drain:
 - engine oil (completely from the crankcase)

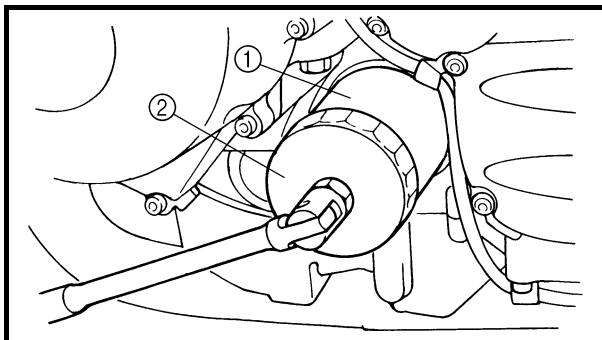

5. If the oil filter cartridge is also to be replaced, perform the following procedure.



- a. Remove the left side cowling. Refer to "COWLINGS AND COVERS".
- b. Remove the oil filter cartridge ① with an oil filter wrench ②.

	<p>Oil filter wrench 90890-01426</p>
---	---

- c. Lubricate the O-ring ③ of the new oil filter cartridge with a thin coat of engine oil.

CAUTION: _____
Make sure the O-ring ③ is positioned correctly in the groove of the oil filter cartridge.

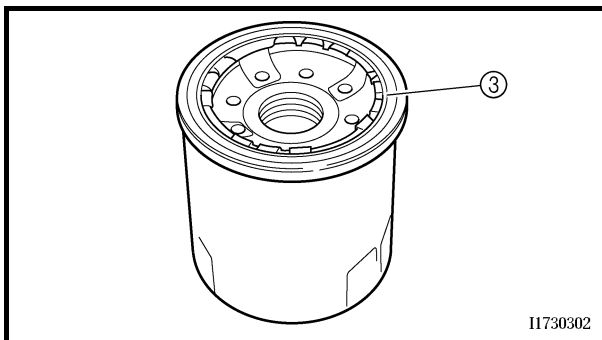

- d. Tighten the new oil filter cartridge to specification with an oil filter wrench.

	<p>Oil filter cartridge 17 Nm (1.7 m · kg)</p>
---	---

- e. Install the left side cowling. Refer to "COWLINGS AND COVERS".





6. Check:
- engine oil drain bolt gasket
Damage → Replace.

7. Install:
- engine oil drain bolt  **43 Nm (4.3 m · kg)**

8. Fill:
- crankcase
(with the specified amount of the recommended engine oil)

	<p>Quantity</p> <p>Total amount 4.9 L</p> <p>Without oil filter cartridge replacement 3.8 L</p> <p>With oil filter cartridge replacement 4.0 L</p>
---	---

9. Install:
- engine oil filler cap
10. Start the engine, warm it up for several minutes, and then turn it off.

11. Check:
- engine
(for engine oil leaks)
12. Check:
- engine oil level
Refer to “CHECKING THE ENGINE OIL LEVEL”.

CHANGING THE ENGINE OIL/ MEASURING THE ENGINE OIL PRESSURE

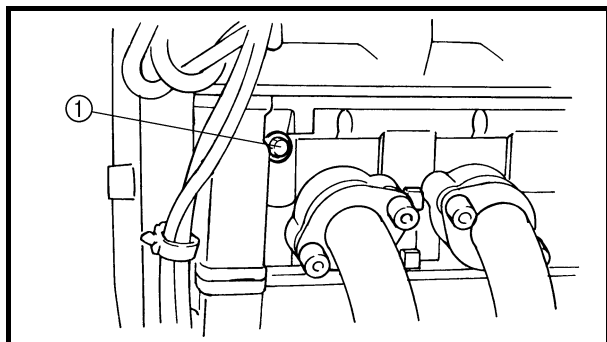

13. Check:
- engine oil pressure



- a. Slightly loosen the oil gallery bolt ①.
- b. Start the engine and keep it idling until engine oil starts to seep from the oil gallery bolt. If no engine oil comes out after one minute, turn the engine off so that it will not seize.
- c. Check the engine oil passages, the oil filter cartridge and the oil pump for damage or leakage. Refer to "OIL PAN AND OIL PUMP" in chapter 5.
- d. Start the engine after solving the problem(s) and check the engine oil pressure again.
- e. Tighten the oil gallery bolt to specification.

	<p>Oil gallery bolt 20 Nm (2.0 m · kg)</p>
---	--



EAS00077

MEASURING THE ENGINE OIL PRESSURE

1. Check:
 - engine oil level
Below the minimum level mark → Add the recommended engine oil to the proper level.
2. Remove:
 - side cowlings
3. Start the engine, warm it up for several minutes, and then turn it off.

CAUTION:

When the engine is cold, the engine oil will have a higher viscosity, causing the engine oil pressure to increase. Therefore, be sure to measure the engine oil pressure after warming up the engine.

4. Remove:
- main gallery bolt

⚠ WARNING

The engine, muffler and engine oil are extremely hot.

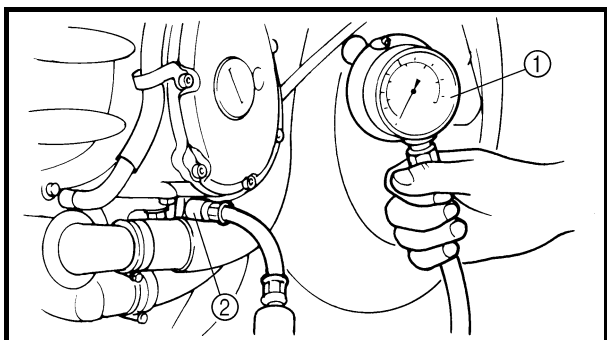

5. Install:
- pressure gauge ①
 - oil pressure adapter B ②

	Pressure gauge 90890-03153 Oil pressure adapter B 90890-03124
---	--

6. Measure:
- engine oil pressure
(at the following conditions)

	Engine oil pressure 65 kPa (0.65 kg/cm², 0.65 bar) Engine speed Approx. 1,000 ~ 1,100 r/min Engine oil temperature 73 °C
---	--

Out of specification → Adjust.

Engine oil pressure	Possible causes
Below specification	<ul style="list-style-type: none"> • Faulty oil pump • Clogged oil filter • Leaking oil passage • Broken or damaged oil seal
Above specification	<ul style="list-style-type: none"> • Leaking oil passage • Faulty oil filter • Oil viscosity too high

7. Install:
- main gallery bolt

	Main gallery bolt 12 Nm (1.2 m · kg)
---	---

ADJUSTING THE CLUTCH LEVER/ CHECKING THE CLUTCH FLUID LEVEL

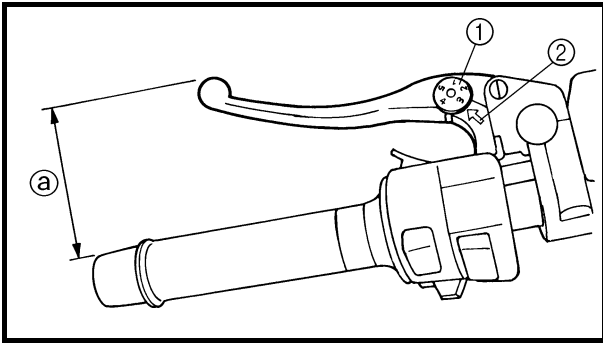

EAS00082

ADJUSTING THE CLUTCH LEVER

1. Adjust:

- clutch lever position
(distance ① from the handlebar grip to the clutch lever)



- a. While pushing the clutch lever forward, turn the adjusting dial ① until the clutch lever is in the desired position.

NOTE: _____

Be sure to align the setting on the adjusting dial with the arrow mark ② on the clutch lever holder.



Position #1	Distance ① is the largest.
Position #5	Distance ① is the smallest.

⚠ WARNING _____

After adjusting the clutch lever position, make sure the pin on the clutch lever holder is firmly inserted in the hole in the adjusting dial.

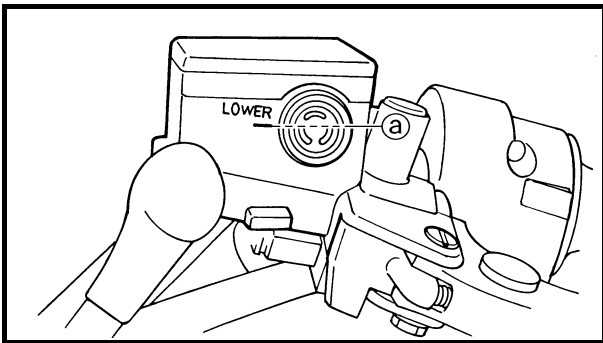

EAS00083

CHECKING THE CLUTCH FLUID LEVEL

1. Stand the motorcycle on a level surface.

NOTE: _____

Place the motorcycle on a suitable stand.



2. Check:

- clutch fluid level
Below the minimum level mark ① → Add the recommended clutch fluid to the proper level.

	Recommended clutch fluid Brake fluid DOT 4
--	---



⚠ WARNING

- Use only the designated clutch fluid. Other clutch fluids may cause the rubber seals to deteriorate, causing leakage and poor clutch performance.
 - Refill with the same type of clutch fluid that is already in the system. Mixing clutch fluids may result in a harmful chemical reaction, leading to poor clutch performance.
 - When refilling, be careful that water does not enter the clutch fluid reservoir. Water will significantly lower the boiling point of the clutch fluid and could cause vapor lock.
-

CAUTION:

Clutch fluid may damage painted surfaces or plastic parts. Therefore, always clean up any spilt clutch fluid immediately.

NOTE:

In order to ensure a correct reading of the clutch fluid level, make sure the top of the reservoir is horizontal.

EAS00084

BLEEDING THE HYDRAULIC CLUTCH SYSTEM

⚠ WARNING

Bleed the hydraulic clutch system whenever:

- the system was disassembled,
 - a clutch hose was loosened or removed,
 - the clutch fluid level is very low,
 - clutch operation is faulty.
-

NOTE:

- Be careful not to spill any clutch fluid or allow the clutch master cylinder reservoir to overflow.
- When bleeding the hydraulic clutch system, make sure there is always enough clutch fluid before applying the clutch lever. Ignoring this precaution could allow air to enter the hydraulic clutch system, considerably lengthening the bleeding procedure.
- If bleeding is difficult, it may be necessary to let the clutch fluid settle for a few hours. Repeat the bleeding procedure when the tiny bubbles in the hose have disappeared.

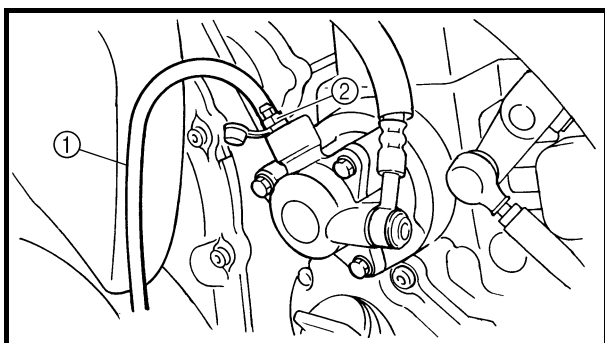

1. Bleed:
 - hydraulic clutch system



- a. Add the recommended clutch fluid to the proper level.
- b. Install the clutch master cylinder reservoir diaphragm.
- c. Connect a clear plastic hose ① tightly to the bleed screw ②.
- d. Place the other end of the hose into a container.
- e. Slowly squeeze the clutch lever several times.
- f. Fully squeeze the clutch lever without releasing it.
- g. Loosen the bleed screw.
This will release the tension and cause the clutch lever to contact the handlebar grip.
- h. Tighten the bleed screw and then release the clutch lever.
- i. Repeat steps (e) to (h) until all of the air bubbles have disappeared from the clutch fluid in the plastic hose.
- j. Tighten the bleed screw to specification.

	<p>Bleed screw 6 Nm (0.6 m · kg)</p>
---	--

- k. Add the recommended clutch fluid to the proper level.
Refer to “CHECKING THE CLUTCH FLUID LEVEL”.

⚠ WARNING

After bleeding the hydraulic clutch system, check the clutch operation.

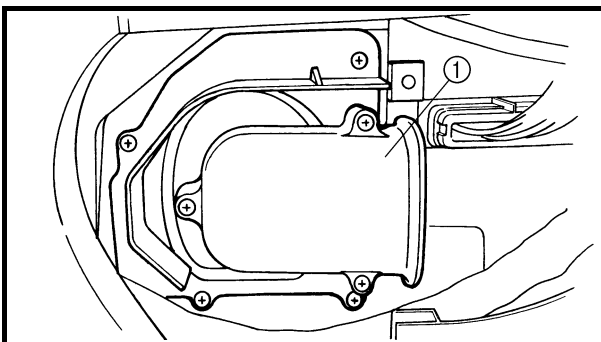
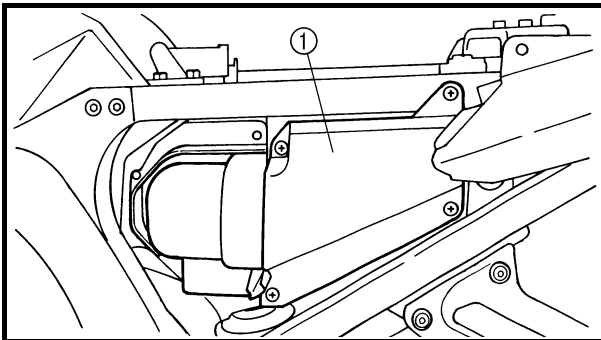

EAS00086

CLEANING THE AIR FILTER ELEMENT

1. Remove:
 - seats
Refer to “SEATS AND FUEL TANK”.
 - left side cover
Refer to “COWLINGS AND COVERS”.
2. Remove:
 - air shroud ①
3. Remove:
 - air filter case cover ①
 - air filter element
4. Clean:
 - air filter element
Apply compressed air to the outer surface of the air filter element.
5. Check:
 - air filter element
Damage → Replace.

6. Install:
 - air filter element
 - air filter case cover

CAUTION:

Never operate the engine without the air filter element installed. Unfiltered air will cause rapid wear of engine parts and may damage the engine. Operating the engine without the air filter element will also affect the throttle body tuning, leading to poor engine performance and possible overheating.

NOTE:

When installing the air filter element into the air filter case cover, make sure their sealing surfaces are aligned to prevent any air leaks.

7. Install:
 - air shroud
8. Install:
 - left side cover
Refer to "COWLINGS AND COVERS".
 - seats
Refer to "SEATS AND FUEL TANK".

EAS00095

CHECKING THE THROTTLE BODY JOINTS

The following procedure applies to all of the throttle body joints.

1. Remove:
 - rider seat
 - fuel tank
Refer to "SEATS AND FUEL TANK".
2. Check:
 - throttle body joint ①
Cracks/damage → Replace.
Refer to "FUEL INJECTION SYSTEM" in chapter 7.
3. Install:
 - fuel tank
 - rider seat
Refer to "SEATS AND FUEL TANK".

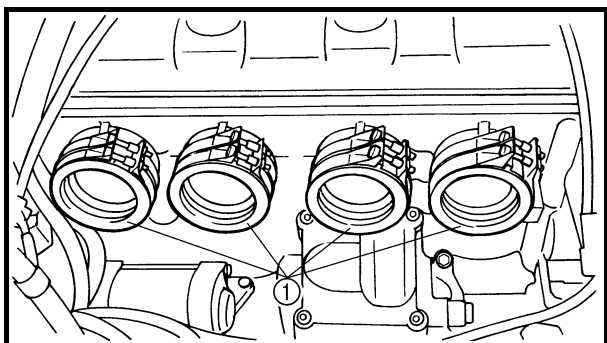

CHECKING THE FUEL AND VACUUM HOSES/ CHECKING THE CRANKCASE BREATHER HOSE



EAS00096

CHECKING THE FUEL AND VACUUM HOSES

The following procedure applies to all of the fuel and vacuum hoses.

1. Remove:
 - rider seat
 - fuel tankRefer to "SEATS AND FUEL TANK".
2. Check:
 - vacuum hose
 - fuel hoseCracks/damage → Replace.
Loose connection → Connect properly.
3. Install:
 - fuel tank
 - rider seatRefer to "SEATS AND FUEL TANK".

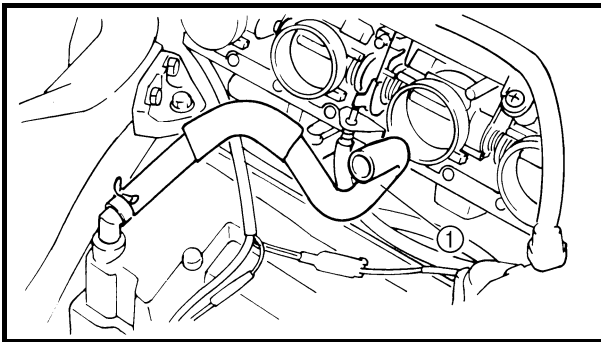

EAS00098

CHECKING THE CRANKCASE BREATHER HOSE

1. Remove:
 - rider seat
 - fuel tankRefer to "SEATS AND FUEL TANK".
 - air filter caseRefer to "AIR FILTER CASE".
2. Check:
 - crankcase breather hose ①Cracks/damage → Replace.
Loose connection → Connect properly.

CAUTION:

Make sure the crankcase breather hose is routed correctly.

3. Install:
 - air filter caseRefer to "AIR FILTER CASE".
 - fuel tank
 - rider seatRefer to "SEATS AND FUEL TANK".

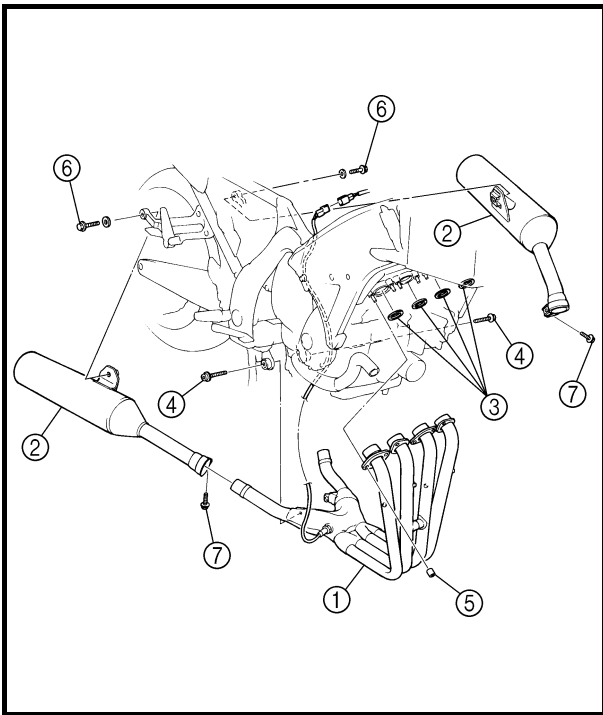

EAS00099

CHECKING THE EXHAUST SYSTEM

The following procedure applies to all of the exhaust pipes and gaskets.

1. Remove:
 - side cowlings
Refer to "COWLINGS AND COVERS".
2. Check:
 - exhaust pipe ①
 - muffler ②
Cracks/damage → Replace.
 - gasket ③
Exhaust gas leaks → Replace.

3. Check:
 - tightening torque

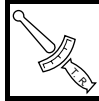

Exhaust pipe assembly and bracket bolt ④

17 Nm (1.7 m · kg)

Exhaust pipe nut ⑤

20 Nm (2.0 m · kg)

Muffler and passenger footrest bracket bolt ⑥

25 Nm (2.5 m · kg)

Exhaust pipe and muffler bolt ⑦

20 Nm (2.0 m · kg)

4. Install:
 - side cowlings
Refer to "COWLINGS AND COVERS".

EAS00102

CHECKING THE COOLANT LEVEL

1. Stand the motorcycle on a level surface.

NOTE: _____

- Place the motorcycle on a suitable stand.
- Make sure the motorcycle is upright.

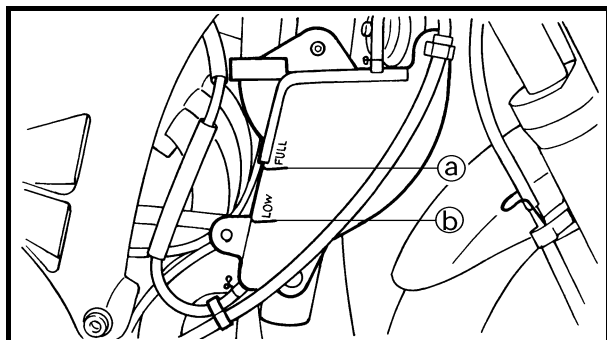

2. Remove:

- right side cowling
Refer to "COWLINGS AND COVERS".

3. Check:

- coolant level
The coolant level should be between the maximum level mark (a) and minimum level mark (b).
Below the minimum level mark → Add the recommended coolant to the proper level.

CAUTION: _____

- Adding water instead of coolant lowers the antifreeze content of the coolant. If water is used instead of coolant check, and if necessary, correct the antifreeze concentration of the coolant.
- Use only distilled water. However, if distilled water is not available soft water may be used.

4. Start the engine, warm it up for several minutes, and then turn it off.

5. Check:

- coolant level

NOTE: _____

Before checking the coolant level, wait a few minutes until it settles.

6. Install:

- side cowling (right)
Refer to "COWLINGS AND COVERS".

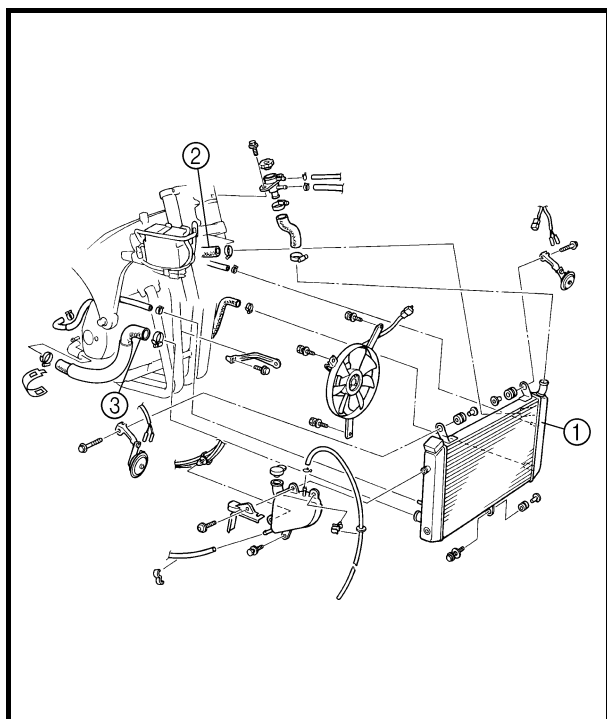

EAS00104

CHECKING THE COOLING SYSTEM

1. Remove:
 - rider seat
 - fuel tank
Refer to "SEATS AND FUEL TANK".
 - side cowlings
 - front cowlings assembly
Refer to "COWLINGS AND COVERS".
2. Check:
 - radiator ①
 - radiator inlet hose ②
 - radiator outlet hose ③
 - oil cooler inlet hose ④
 - oil cooler outlet hose ⑤
 - water jacket joint ⑥
Cracks/damage → Replace.
Refer to "COOLING SYSTEM" in chapter 6.
3. Install:
 - front cowlings assembly
 - side cowlings
Refer to "COWLINGS AND COVERS".
 - fuel tank
 - rider seat
Refer to "SEATS AND FUEL TANK".

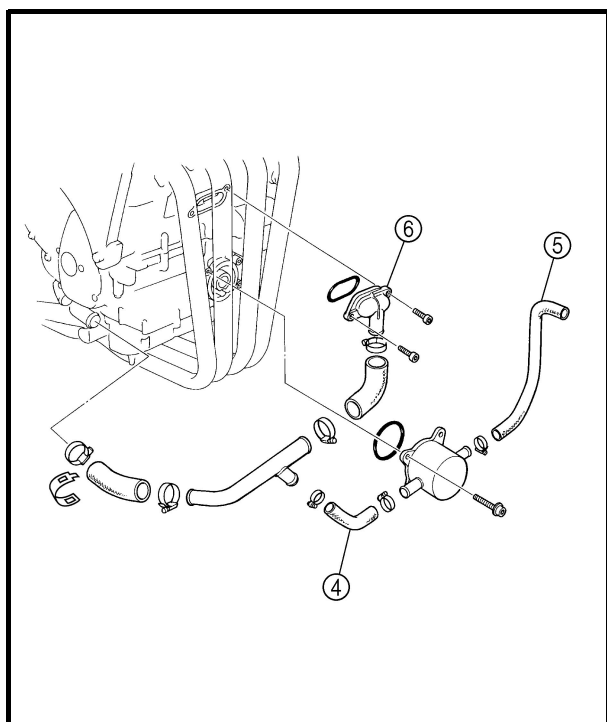

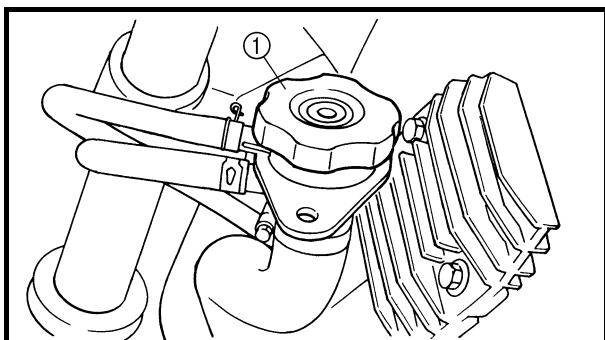
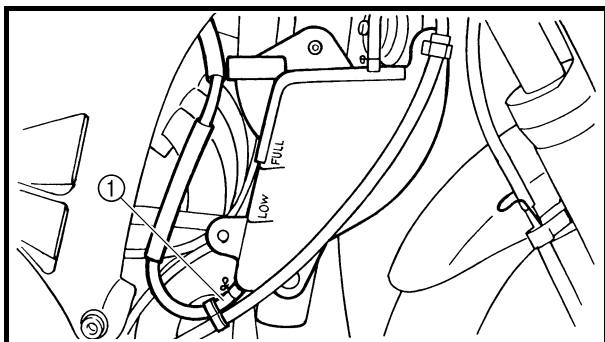

EAS00105

CHANGING THE COOLANT

1. Stand the motorcycle on a level surface.

NOTE:

- Place the motorcycle on a suitable stand.
- Make sure the motorcycle is upright.

2. Remove:

- side cowlings
 - front cowl assembly
- Refer to "COWLINGS AND COVERS".

3. Disconnect:

- coolant reservoir hose ①

4. Drain:

- coolant
(from the coolant reservoir)

5. Remove:

- radiator cap ①

⚠ WARNING

A hot radiator is under pressure. Therefore, do not remove the radiator cap when the engine is hot. Scalding hot fluid and steam may be blown out, which could cause serious injury. When the engine has cooled, open the radiator cap as follows:

Place a thick rag or a towel over the radiator cap and slowly turn the radiator cap counterclockwise toward the detent to allow any residual pressure to escape. When the hissing sound has stopped, press down on the radiator cap and turn it counterclockwise to remove.

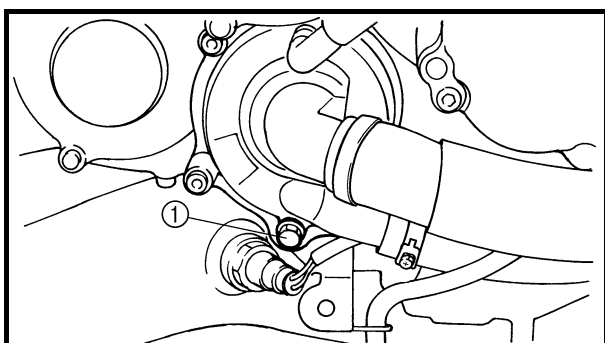

The following procedure applies to all of the coolant drain bolts and copper washers.

6. Remove:

- coolant drain bolt ①
(along with the copper washer)

7. Drain:

- coolant
(from the engine and radiator)

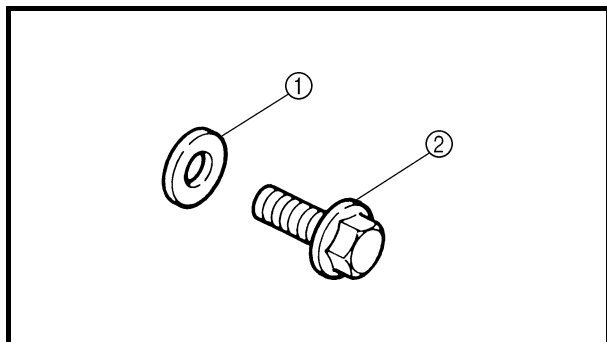

8. Check:
- copper washer ① (coolant drain bolt ②)
Damage → Replace.

9. Install:

- coolant drain bolt  **10 Nm (1.0 m · kg)**

10. Connect:

- coolant reservoir hose

11. Fill:

- cooling system
(with the specified amount of the recommended coolant)



Recommended antifreeze

High-quality ethylene glycol antifreeze containing corrosion inhibitors for aluminum engines

Mixing ratio

1 : 1 (antifreeze : water)

Quantity

Total amount

3.2 L

Coolant reservoir capacity

0.485 L

From minimum to maximum level mark

0.15 L

Handling notes for coolant

Coolant is potentially harmful and should be handled with special care.

⚠ WARNING

- If coolant splashes in your eyes, thoroughly wash them with water and consult a doctor.
- If coolant splashes on your clothes, quickly wash it away with water and then with soap and water.
- If coolant is swallowed, induce vomiting and get immediate medical attention.

CAUTION:

- Adding water instead of coolant lowers the antifreeze content of the coolant. If water is used instead of coolant check, and if necessary, correct the antifreeze concentration of the coolant.
- Use only distilled water. However, if distilled water is not available, soft water may be used.
- If coolant comes into contact with painted surfaces, immediately wash them with water.
- Do not mix different types of antifreeze.

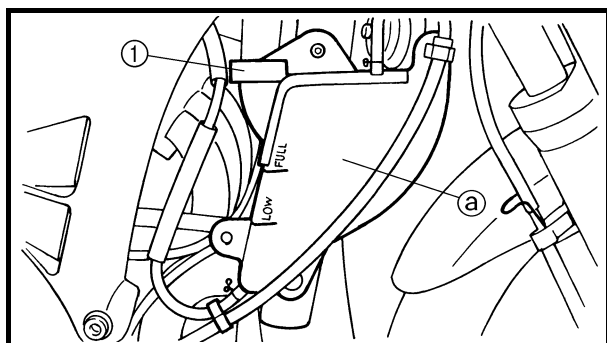

12. Install:
 - radiator cap
13. Remove:
 - coolant reservoir cap cover ①
 - coolant reservoir cap
14. Fill:
 - coolant reservoir
(with the recommended coolant to the maximum level mark ②)
15. Install:
 - coolant reservoir cap
 - coolant reservoir cap cover
16. Start the engine, warm it up for several minutes, and then stop it.
17. Check:
 - coolant level
Refer to "CHECKING THE COOLANT LEVEL".

NOTE:

Before checking the coolant level, wait a few minutes until the coolant has settled.

18. Install:
 - front cowl assembly
 - side cowlings
Refer to "COWLINGS AND COVERS".

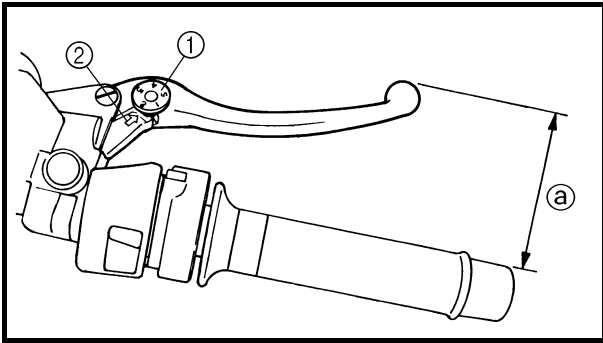

EAS00107

CHASSIS

ADJUSTING THE FRONT BRAKE

1. Adjust:

- brake lever position
(distance ① from the throttle grip to the brake lever)

NOTE:

- While pushing the brake lever forward, turn the adjusting dial ① until the brake lever is in the desired position.
- Be sure to align the setting on the adjusting dial with the arrow mark ② on the brake lever holder.

Position #1	Distance ① is the largest.
Position #5	Distance ① is the smallest.

⚠ WARNING

- After adjusting the brake lever position, make sure the pin on the brake lever holder is firmly inserted in the hole in the adjusting dial.
- A soft or spongy feeling in the brake system lever can indicate the presence of air in the brake system. Before the vehicle is operated, the air must be removed by bleeding the brake system. Air in the brake system will considerably reduce braking performance and could result in loss of control and possibly an accident. Therefore, check and if necessary, bleed the brake system.

CAUTION:

After adjusting the brake lever position, make sure there is no brake drag.

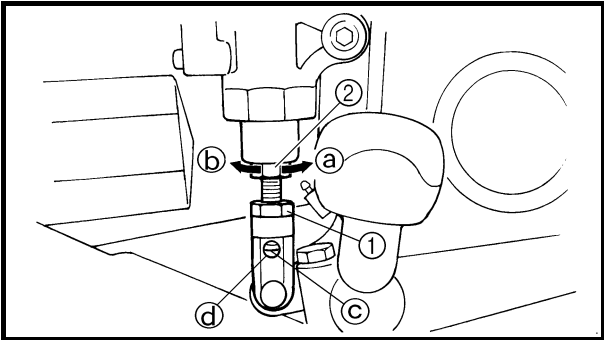
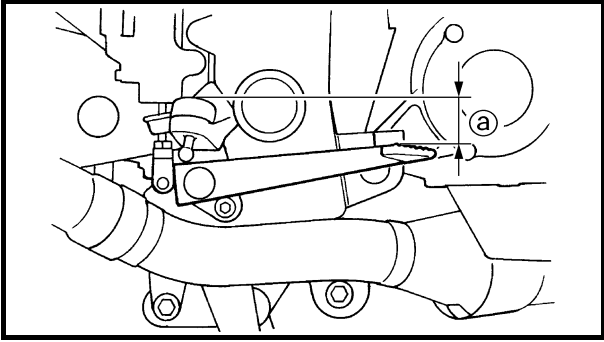

EAS00110

ADJUSTING THE REAR BRAKE

1. Check:

- brake pedal position
(distance (a) from the top of the rider footrest to the top of the brake pedal)
Out of specification → Adjust.



Brake pedal position (below the top of the rider footrest)
42 mm

2. Adjust:

- brake pedal position



- a. Loosen the locknut (1).
- b. Turn the adjusting bolt (2) in direction (a) or (b) until the specified brake pedal position is obtained.

Direction (a)	Brake pedal is raised.
Direction (b)	Brake pedal is lowered.

⚠ WARNING

After adjusting the brake pedal position, check that the end of the adjusting bolt (c) is visible through the hole (d).

- c. Tighten the locknut (1) to specification.



Locknut
16 Nm (1.6 m · kg)

⚠ WARNING

A soft or spongy feeling in the brake pedal can indicate the presence of air in the brake system. Before the vehicle is operated, the air must be removed by bleeding the brake system. Air in the brake system will considerably reduce braking performance and could result in loss of control and possibly an accident. Therefore, check and, if necessary, bleed the brake system.

CAUTION:

After adjusting the brake pedal position, make sure there is no brake drag.



ADJUSTING THE REAR BRAKE/ CHECKING THE BRAKE FLUID LEVEL



3. Adjust:
 - rear brake light switch
Refer to “ADJUSTING THE REAR BRAKE LIGHT SWITCH”.

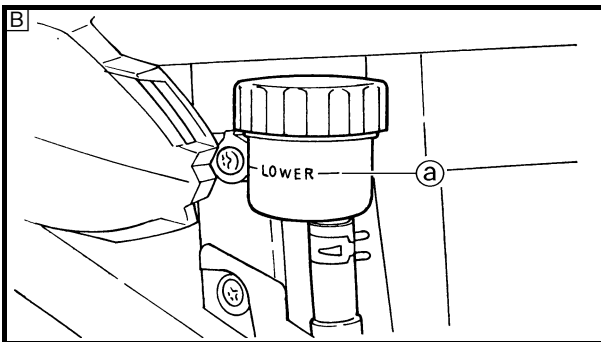
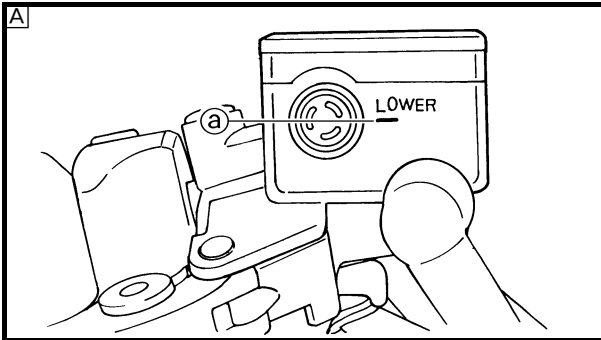

EAS00115

CHECKING THE BRAKE FLUID LEVEL

1. Stand the motorcycle on a level surface.

NOTE:

- Place the motorcycle on a suitable stand.
- Make sure the motorcycle is upright.

2. Remove: (rear brake only)

- seats
Refer to “SEATS AND FUEL TANK”.
- right side cover
Refer to “COWLINGS AND COVERS”.

3. Check:

- brake fluid level
Below the minimum level mark (a) → Add the recommended brake fluid to the proper level.



**Recommended brake fluid
DOT 4**

A Front brake

B Rear brake

⚠ WARNING

- Use only the designated brake fluid. Other brake fluids may cause the rubber seals to deteriorate, causing leakage and poor brake performance.
- Refill with the same type of brake fluid that is already in the system. Mixing brake fluids may result in a harmful chemical reaction, leading to poor brake performance.
- When refilling, be careful that water does not enter the brake fluid reservoir. Water will significantly lower the boiling point of the brake fluid and could cause vapor lock.

CAUTION:

Brake fluid may damage painted surfaces and plastic parts. Therefore, always clean up any spilt brake fluid immediately.

NOTE:

In order to ensure a correct reading of the brake fluid level, make sure the top of the brake fluid reservoir is horizontal.

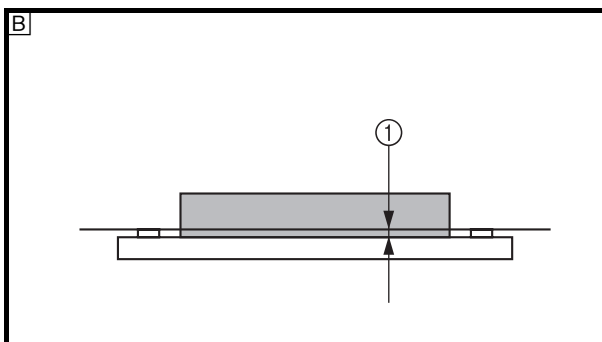
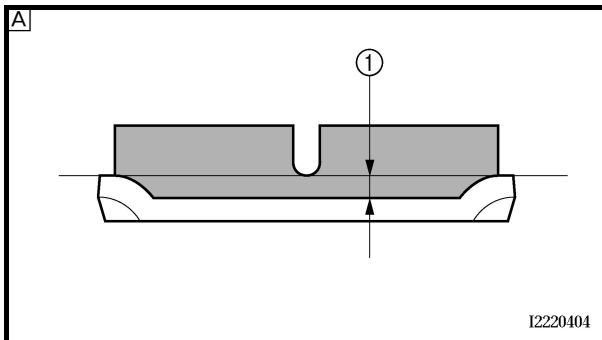

EAS00118

CHECKING THE BRAKE PADS

The following procedure applies to all of the brake pads.

1. Operate the brake.
2. Check:
 - front brake pad
Wear indicator ① almost touch the brake disc → Replace the brake pads as a set. Refer to “FRONT AND REAR BRAKES” in chapter 4.
 - rear brake pad
Wear indicator ① almost touch the brake disc → Replace the brake pads as a set. Refer to “FRONT AND REAR BRAKES” in chapter 4.

- A Front brake
B Rear brake

EAS00128

ADJUSTING THE REAR BRAKE LIGHT SWITCH

NOTE:

The rear brake light switch is operated by movement of the brake pedal. The rear brake light switch is properly adjusted when the brake light comes on just before the braking effect starts.

EAS00134

BLEEDING THE HYDRAULIC BRAKE SYSTEM

⚠ WARNING

Bleed the hydraulic brake system whenever: the system is disassembled, a brake hose is loosened, disconnected or replaced, the brake fluid level is very low, brake operation is faulty.

NOTE:

- Be careful not to spill any brake fluid or allow the brake master cylinder reservoir or brake fluid reservoir to overflow.
- When bleeding the hydraulic brake system, make sure there is always enough brake fluid before applying the brake. Ignoring this precaution could allow air to enter the hydraulic brake system, considerably lengthening the bleeding procedure.
- If bleeding is difficult, it may be necessary to let the brake fluid settle for a few hours.
- Repeat the bleeding procedure when the tiny bubbles in the hose have disappeared.

1. Remove:

- right side cover
Refer to "COWLINGS AND COVERS".

2. Bleed:

- hydraulic brake system

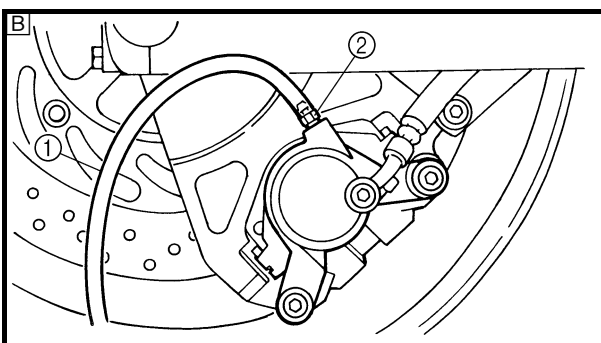
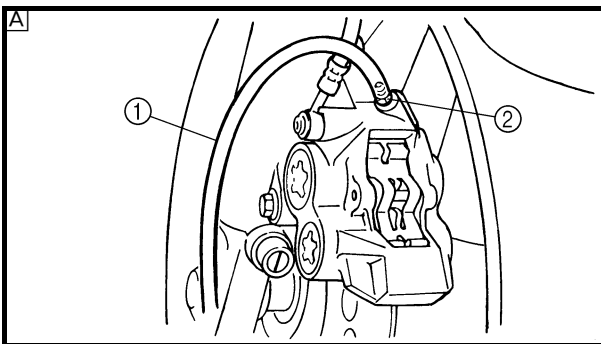

- a. Fill the brake fluid reservoir to the proper level with the recommended brake fluid.
 - b. Install the diaphragm (brake master cylinder reservoir or brake fluid reservoir).
 - c. Connect a clear plastic hose ① tightly to the bleed screw ②.
- A Front
 B Rear
- d. Place the other end of the hose into a container.
 - e. Slowly apply the brake several times.
 - f. Fully squeeze the brake lever or fully depress the brake pedal and hold it in position.

BLEEDING THE HYDRAULIC BRAKE SYSTEM/ ADJUSTING THE SHIFT PEDAL



g. Loosen the bleed screw.

NOTE: _____

Loosening the bleed screw will release the pressure and cause the brake lever to contact the throttle grip or the brake pedal to fully extend.

h. Tighten the bleed screw and then release the brake lever or brake pedal.

i. Repeat steps (e) to (h) until all of the air bubbles have disappeared from the brake fluid in the plastic hose.

j. Tighten the bleed screw to specification.

	Bleed screw 6 Nm (0.6 m · kg)
---	--

k. Fill the brake fluid reservoir to the proper level with the recommended brake fluid.

Refer to "CHECKING THE BRAKE FLUID LEVEL".

⚠ WARNING _____

After bleeding the hydraulic brake system, check the brake operation.

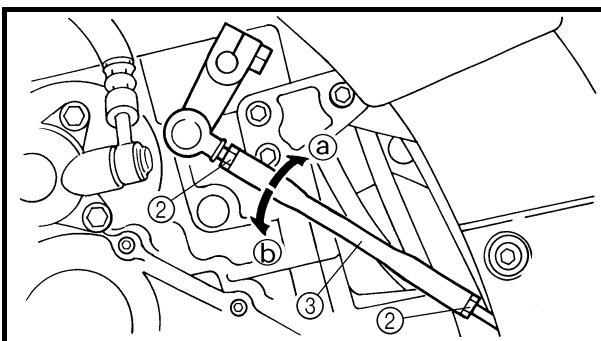
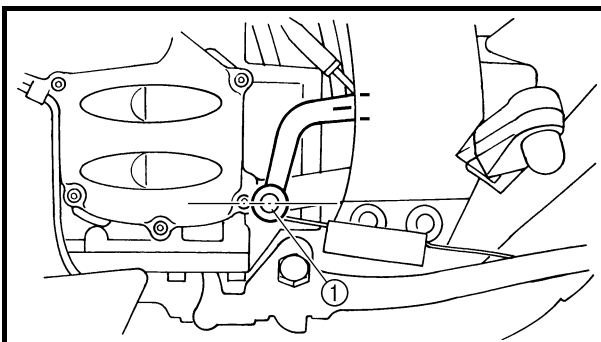

EAS00136

ADJUSTING THE SHIFT PEDAL

1. Check:

- shift pedal position

The end ① of the shift pedal with the left middle gear cover bolt.

Incorrect → Adjust.

2. Adjust:

- shift pedal position



a. Loosen both locknuts ②.

b. Turn the shift rod ③ in direction ① or ② to obtain the correct shift pedal position.

Direction ①	Shift pedal is raised.
Direction ②	Shift pedal is lowered.

NOTE: _____
Make sure that the mark on the shift pedal is between the marks on the frame.

c. Tighten both locknuts.

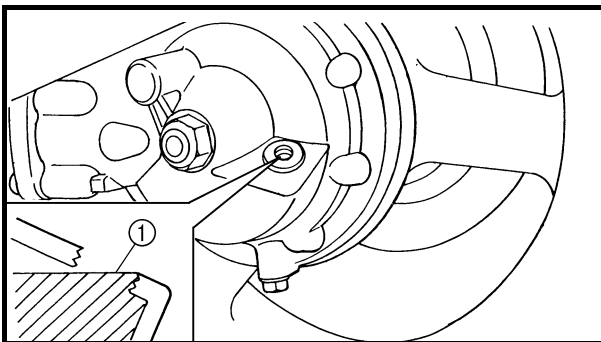
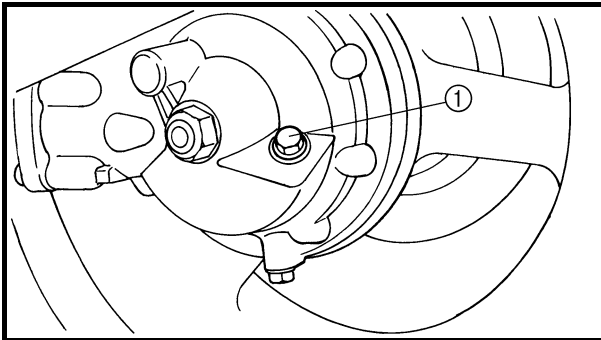

EAS00144

CHECKING THE FINAL DRIVE OIL LEVEL

1. Stand the motorcycle on a level surface.

NOTE: _____

- Place the motorcycle on a suitable stand.
- Make sure the motorcycle is upright.

2. Remove:

- final drive housing oil filler bolt ①

3. Check:

- final drive oil level
The final drive oil level should be to the bottom brim ① of the filler hole.
Below the bottom brim → Add the recommended final drive oil to the proper level.

	Recommended oil Drive shaft gear oil
---	---

4. Install:

- final drive housing oil filler bolt

 **23 Nm (2.3 m · kg)**

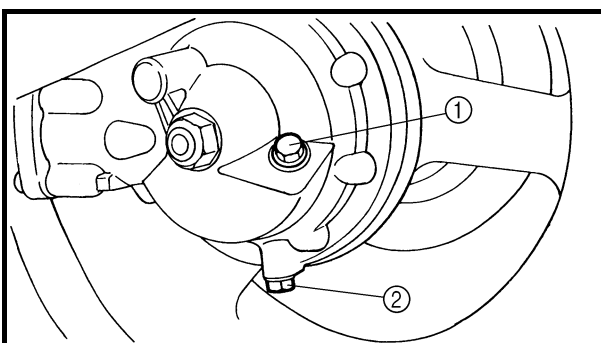

EAS00145

CHANGING THE FINAL DRIVE OIL

1. Place a container under the final drive housing.

2. Remove:

- final drive housing oil filler bolt ①
- final drive housing oil drain bolt ②

Completely drain the final drive housing of its oil.

CHANGING THE FINAL DRIVE OIL/ CHECKING AND ADJUSTING THE STEERING HEAD



3. Check:
 - final drive housing oil drain bolt gasket
Damage → Replace.
4. Install:
 - final drive housing oil drain bolt

 **23 Nm (2.3 m · kg)**

5. Fill:
 - final drive housing
(with the specified amount of the recommended final drive oil)



Refer to “CHECKING THE FINAL DRIVE OIL LEVEL”.

EAS00147

CHECKING AND ADJUSTING THE STEERING HEAD

1. Stand the motorcycle on a level surface.

WARNING

Securely support the motorcycle so that there is no danger of it falling over.

NOTE:

Place the motorcycle on a suitable stand so that the front wheel is elevated.

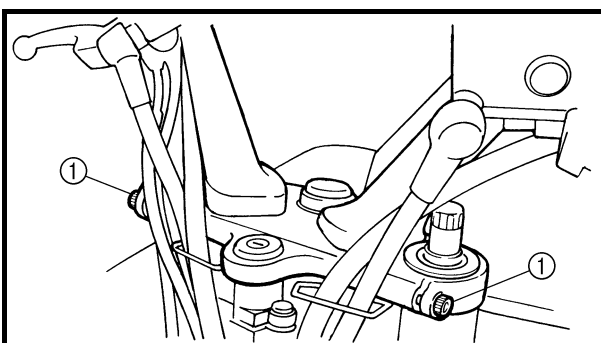
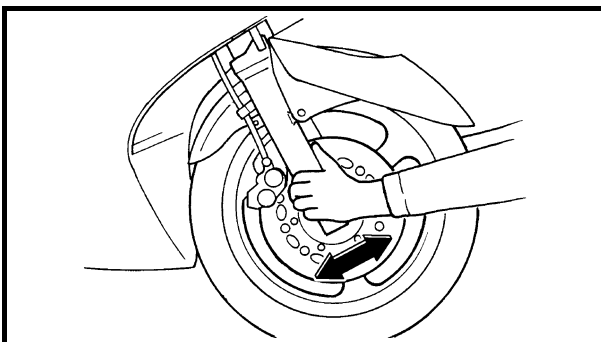

2. Check:
 - steering head
Grasp the bottom of the front fork legs and gently rock the front fork.
Binding/looseness → Adjust the steering head.
3. Loosen:
 - upper bracket pinch bolts ①

CHECKING AND ADJUSTING THE STEERING HEAD/ CHECKING THE FRONT FORK

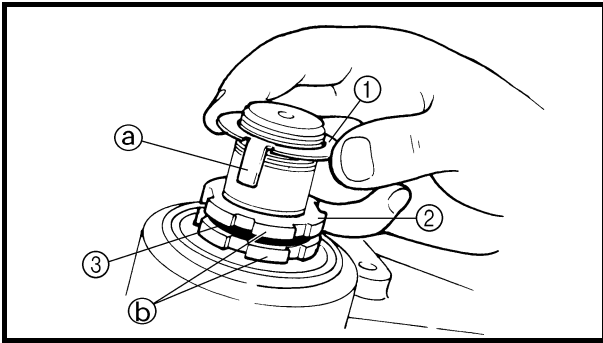

- g. Finger tighten the upper ring nut, then align the slots of both ring nuts. If necessary, hold the lower ring nut and tighten the upper ring nut until their slots are aligned.
- h. Install the lock washer.

NOTE: _____
Make sure the lock washer tabs (a) sit correctly in the ring nut slots (b).



- 6. Install:
 - upper bracket (with the handlebars)
 - washer
 - steering stem nut 115 Nm (11.5 m · kg)
- 7. Tighten:
 - upper bracket pinch bolts 34 Nm (3.4 m · kg)

EAS00150

CHECKING THE FRONT FORK

- 1. Stand the motorcycle on a level surface.

WARNING

Securely support the motorcycle so that there is no danger of it falling over.

- 2. Check:
 - inner tube
Damage/scratches → Replace.
 - oil seal
Oil leakage → Replace.
- 3. Hold the motorcycle upright and apply the front brake.

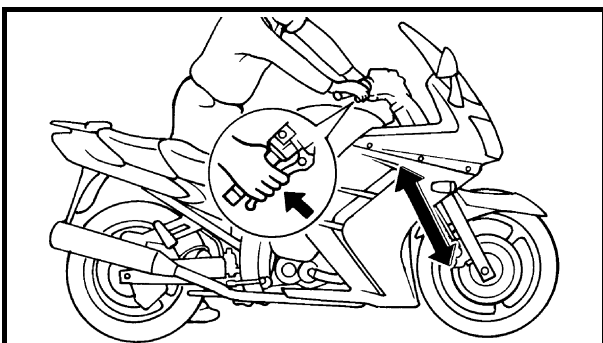

- 4. Check:
 - front fork operation
Push down hard on the handlebars several times and check if the front fork rebounds smoothly.
Rough movement → Repair.
Refer to “FRONT FORK” in chapter 4.

EAS00155

ADJUSTING THE FRONT FORK LEGS

The following procedure applies to both of the front fork legs.

WARNING

- Always adjust both front fork legs evenly. Uneven adjustment can result in poor handling and loss of stability.
- Securely support the motorcycle so that there is no danger of it falling over.

Spring preload

CAUTION:

- Grooves are provided to indicate the adjustment position.
- Never go beyond the maximum or minimum adjustment positions.

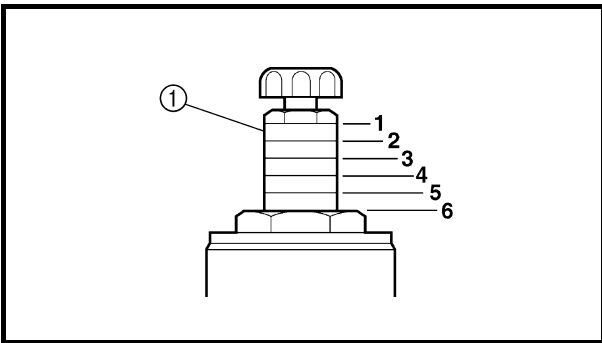
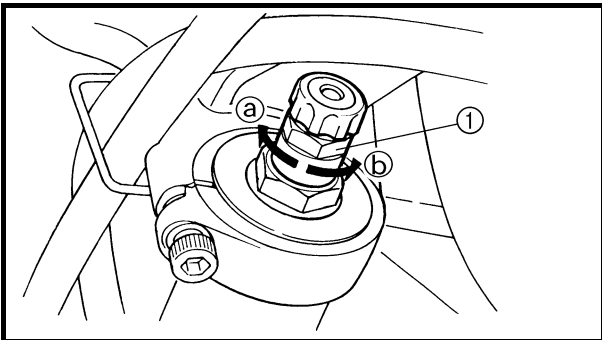

1. Adjust:
 - spring preload



- a. Turn the adjusting bolt ① in direction ② or ③.

Direction ②	Spring preload is increased (suspension is harder).
Direction ③	Spring preload is decreased (suspension is softer).

Adjusting positions
Minimum: 1
Standard: 3
Maximum: 6



Rebound damping

CAUTION:

Never go beyond the maximum or minimum adjustment positions.

1. Adjust:
 - rebound damping

ADJUSTING THE REAR SHOCK ABSORBER ASSEMBLY

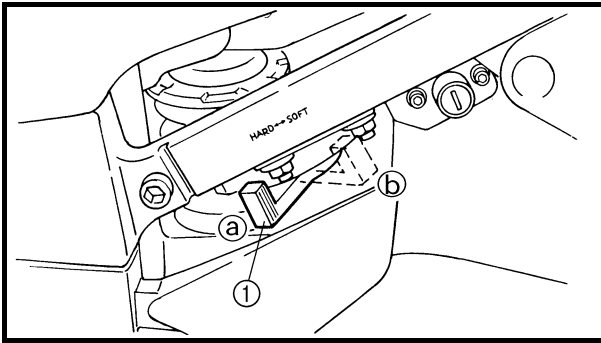

EAS00157

ADJUSTING THE REAR SHOCK ABSORBER ASSEMBLY

⚠ WARNING

Securely support the motorcycle so that there is no danger of it falling over.

Spring preload

- Adjust:
 - spring preload



- Move the adjusting lever ① in direction ① or ②.
- Adjust the adjusting lever to HARD or SOFT.

Position ①	Spring preload is increased (suspension is harder).
Position ②	Spring preload is decreased (suspension is softer).

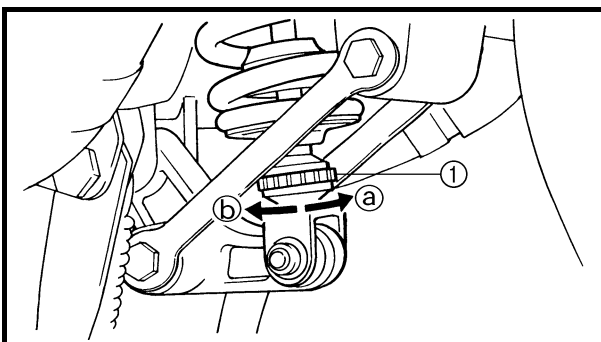

Rebound damping

CAUTION:

Never go beyond the maximum or minimum adjustment positions.

- Adjust:
 - rebound damping



- Turn the adjusting knob ① in direction ① or ②.

Direction ①	Rebound damping is increased (suspension is harder).
Direction ②	Rebound damping is decreased (suspension is softer).

ADJUSTING THE REAR SHOCK ABSORBER ASSEMBLY/CHECKING THE TIRES



Adjusting positions
Minimum: 20 clicks out*
Standard: 10 clicks out*
Maximum: 3 clicks out*

* from the fully turned-in position (a)

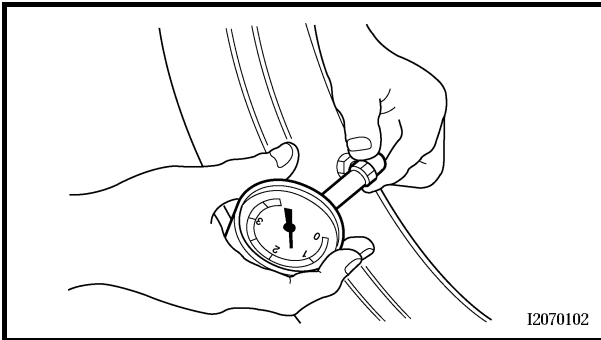

I2070102

EAS00162

CHECKING THE TIRES

The following procedure applies to both of the tires.

1. Measure:
 - tire pressure
 - Out of specification → Regulate.

⚠ WARNING

- The tire pressure should only be checked and regulated when the tire temperature equals the ambient air temperature.
- The tire pressure and the suspension must be adjusted according to the total weight (including cargo, rider, passenger and accessories) and the anticipated riding speed.
- Operation of an overloaded motorcycle could cause tire damage, an accident or an injury.

NEVER OVERLOAD THE MOTORCYCLE.

Basic weight (with oil and a full fuel tank)	268 kg	
Maximum load*	208 kg	
Cold tire pressure	Front	Rear
Up to 90 kg load*	250 kPa (2.5 kgf/cm ² , 2.5 bar)	250 kPa (2.5 kgf/cm ² , 2.5 bar)
90 kg ~ maximum load*	250 kPa (2.5 kgf/cm ² , 2.5 bar)	290 kPa (2.9 kgf/cm ² , 2.9 bar)
High-speed riding	250 kPa (2.5 kgf/cm ² , 2.5 bar)	290 kPa (2.9 kgf/cm ² , 2.9 bar)

* total of cargo, rider, passenger and accessories

⚠ WARNING

It is dangerous to ride with a worn-out tire. When the tire tread reaches the wear limit, replace the tire immediately.

2. Check:

- tire surfaces
Damage/wear → Replace the tire.

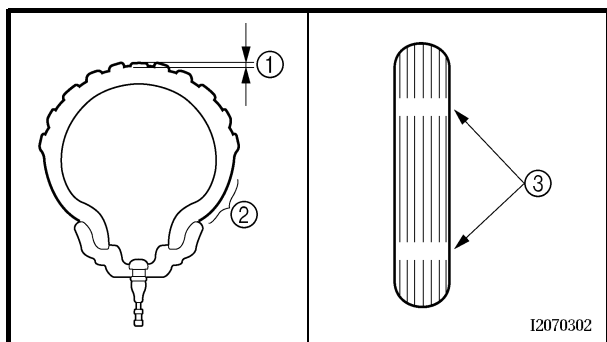

	Minimum tire tread depth 1.6 mm
---	--

- ① Tire tread depth
- ② Sidewall
- ③ Wear indicator

⚠ WARNING

- Do not use a tubeless tire on a wheel designed only for tube tires to avoid tire failure and personal injury from sudden deflation.
- When using a tube tire, be sure to install the correct tube.
- Always replace a new tube tire and a new tube as a set.
- To avoid pinching the tube, make sure the wheel rim band and tube are centered in the wheel groove.
- Patching a punctured tube is not recommended. If it is absolutely necessary to do so, use great care and replace the tube as soon as possible with a good quality replacement.

- A Tire
- B Wheel

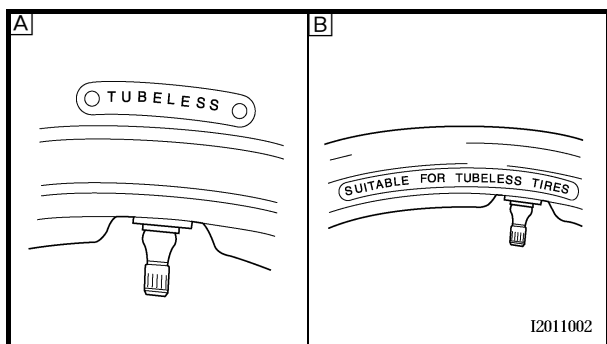

Tube wheel	Tube tire only
Tubeless wheel	Tube or tubeless tire

- After extensive tests, the tires listed below have been approved by Yamaha Motor Co., Ltd. for this model. The front and rear tires should always be by the same manufacturer and of the same design. No guarantee concerning handling characteristics can be given if a tire combination other than one approved by Yamaha is used on this motorcycle.

CHECKING THE TIRES/ CHECKING THE WHEELS



Front tire

Manufacturer	Model	Size
METZELER	MEZ4B FRONT	120/70ZR17 (58W)
BRIDGESTONE	BT020F N	120/70ZR17 (58W)

Rear tire

Manufacturer	Model	Size
METZELER	MEZ4J	180/55ZR17 (73W)
BRIDGESTONE	BT020R N	180/55ZR17 (73W)

⚠ WARNING

New tires have a relatively low grip on the road surface until they have been slightly worn. Therefore, approximately 100 km should be traveled at normal speed before any high-speed riding is done.

NOTE:

For tires with a direction of rotation mark ④:

- Install the tire with the mark pointing in the direction of wheel rotation.
- Align the mark ⑤ with the valve installation point.

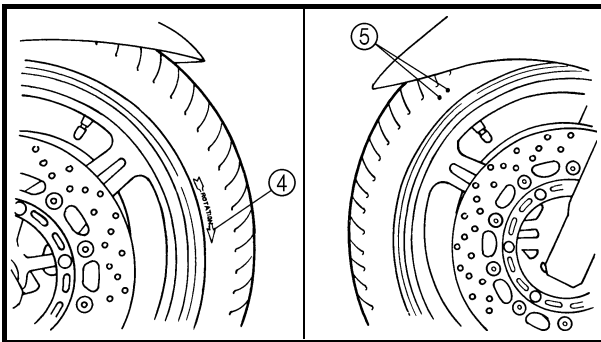

EAS00168

CHECKING THE WHEELS

The following procedure applies to both of the wheels.

1. Check:

- wheel
Damage/out-of-round → Replace.

⚠ WARNING

Never attempt to make any repairs to the wheel.

NOTE:

After a tire or wheel has been changed or replaced, always balance the wheel.

EAS00170

CHECKING AND LUBRICATING THE CABLES

The following procedure applies to all of the cable sheaths and cables.

⚠ WARNING

Damaged cable sheaths may cause the cable to corrode and interfere with its movement. Replace damaged cable sheaths and cables as soon as possible.

1. Check:
 - cable sheath
Damage → Replace.
2. Check:
 - cable operation
Rough movement → Lubricate.

	Recommended lubricant Engine oil or a suitable cable lubricant
---	--

NOTE:

Hold the cable end upright and pour a few drops of lubricant into the cable sheath or use a suitable lubricating device.

EAS00171

LUBRICATING THE LEVERS AND PEDALS

Lubricate the pivoting point and metal-to-metal moving parts of the levers and pedals.

	Recommended lubricant Lithium soap base grease
---	--

EAS00172

LUBRICATING THE SIDESTAND

Lubricate the pivoting point and metal-to-metal moving parts of the sidestand.

	Recommended lubricant Lithium soap base grease
---	--

LUBRICATING THE CENTERSTAND/ LUBRICATING THE REAR SUSPENSION



EAS00173

LUBRICATING THE CENTERSTAND

Lubricate the pivoting point and metal-to-metal moving parts of the centerstand.



EAS00174

LUBRICATING THE REAR SUSPENSION

Lubricate the pivoting point and metal-to-metal moving parts of the rear suspension.



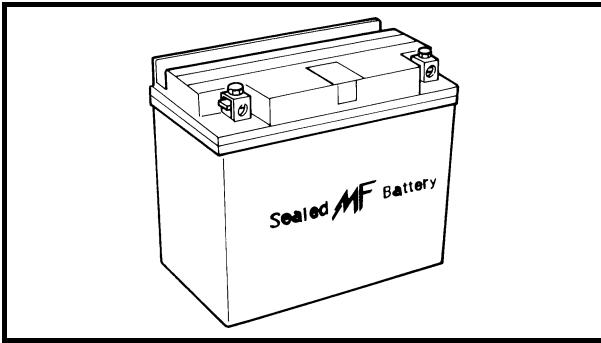

EAS00178

ELECTRICAL SYSTEM CHECKING AND CHARGING THE BATTERY

⚠ WARNING

Batteries generate explosive hydrogen gas and contain electrolyte which is made of poisonous and highly caustic sulfuric acid. Therefore, always follow these preventive measures:

- Wear protective eye gear when handling or working near batteries.
- Charge batteries in a well-ventilated area.
- Keep batteries away from fire, sparks or open flames (e.g., welding equipment, lighted cigarettes).
- **DO NOT SMOKE** when charging or handling batteries.
- **KEEP BATTERIES AND ELECTROLYTE OUT OF REACH OF CHILDREN.**
- Avoid bodily contact with electrolyte as it can cause severe burns or permanent eye injury.

FIRST AID IN CASE OF BODILY CONTACT: EXTERNAL

- Skin — Wash with water.
- Eyes — Flush with water for 15 minutes and get immediate medical attention.

INTERNAL

- Drink large quantities of water or milk followed with milk of magnesia, beaten egg or vegetable oil. Get immediate medical attention.

CAUTION:

- This is a sealed battery. Never remove the sealing caps because the balance between cells will not be maintained and battery performance will deteriorate.
- Charging time, charging amperage and charging voltage for an MF battery are different from those of conventional batteries. The MF battery should be charged as explained in the charging method illustrations. If the battery is overcharged, the electrolyte level will drop considerably. Therefore, take special care when charging the battery.

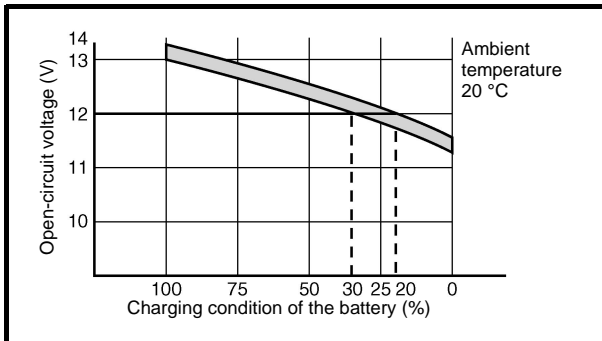
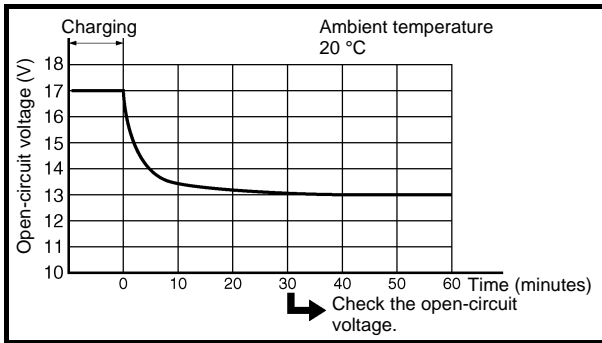

5. Charge:

- battery
(refer to the appropriate charging method illustration)

⚠ WARNING

Do not quick charge a battery.

CAUTION:

- Never remove the MF battery sealing caps.
- Do not use a high-rate battery charger since it forces a high-amperage current into the battery quickly and can cause battery overheating and battery plate damage.
- If it is impossible to regulate the charging current on the battery charger, be careful not to overcharge the battery.
- When charging a battery, be sure to remove it from the motorcycle. (If charging has to be done with the battery mounted on the motorcycle, disconnect the negative battery lead from the battery terminal.)
- To reduce the chance of sparks, do not plug in the battery charger until the battery charger leads are connected to the battery.
- Before removing the battery charger lead clips from the battery terminals, be sure to turn off the battery charger.
- Make sure the battery charger lead clips are in full contact with the battery terminal and that they are not shorted. A corroded battery charger lead clip may generate heat in the contact area and a weak clip spring may cause sparks.
- If the battery becomes hot to the touch at any time during the charging process, disconnect the battery charger and let the battery cool before reconnecting it. Hot batteries can explode!
- As shown in the following illustration, the open-circuit voltage of an MF battery stabilizes about 30 minutes after charging has been completed. Therefore, wait 30 minutes after charging is completed before measuring the open-circuit voltage.

CHECKING AND CHARGING THE BATTERY



Charging method using a variable voltage charger

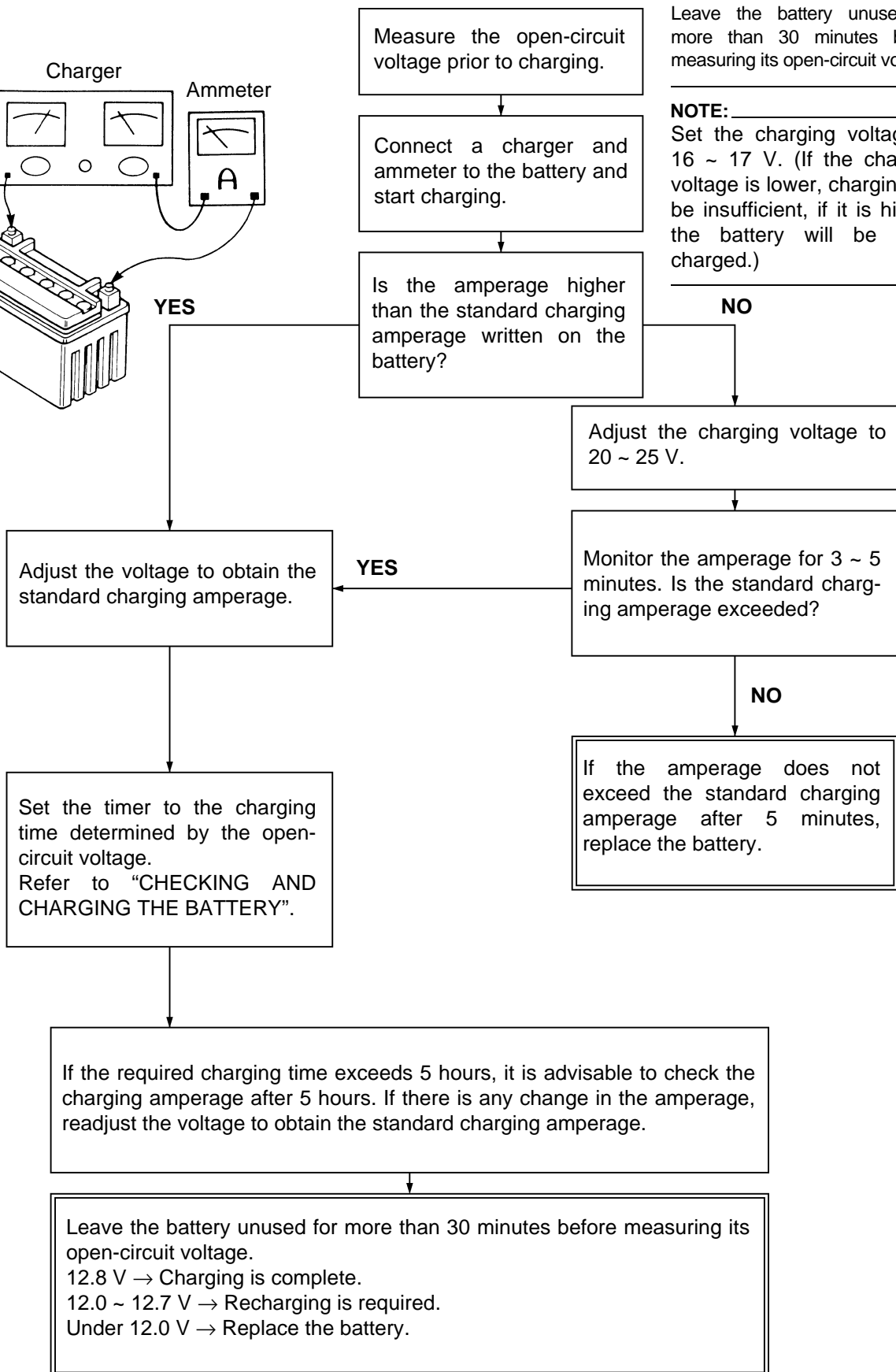
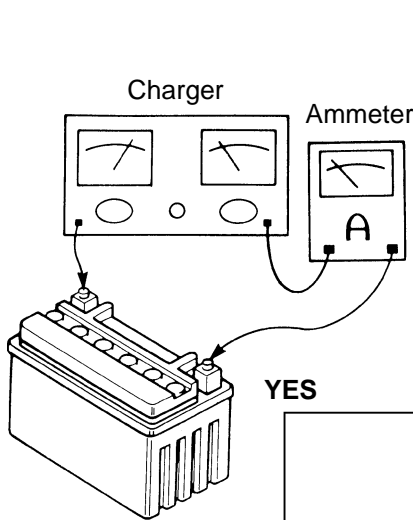

NOTE:
Leave the battery unused for more than 30 minutes before measuring its open-circuit voltage.

NOTE:
Set the charging voltage to 16 ~ 17 V. (If the charging voltage is lower, charging will be insufficient, if it is higher, the battery will be over-charged.)

Charging method using a constant voltage charger

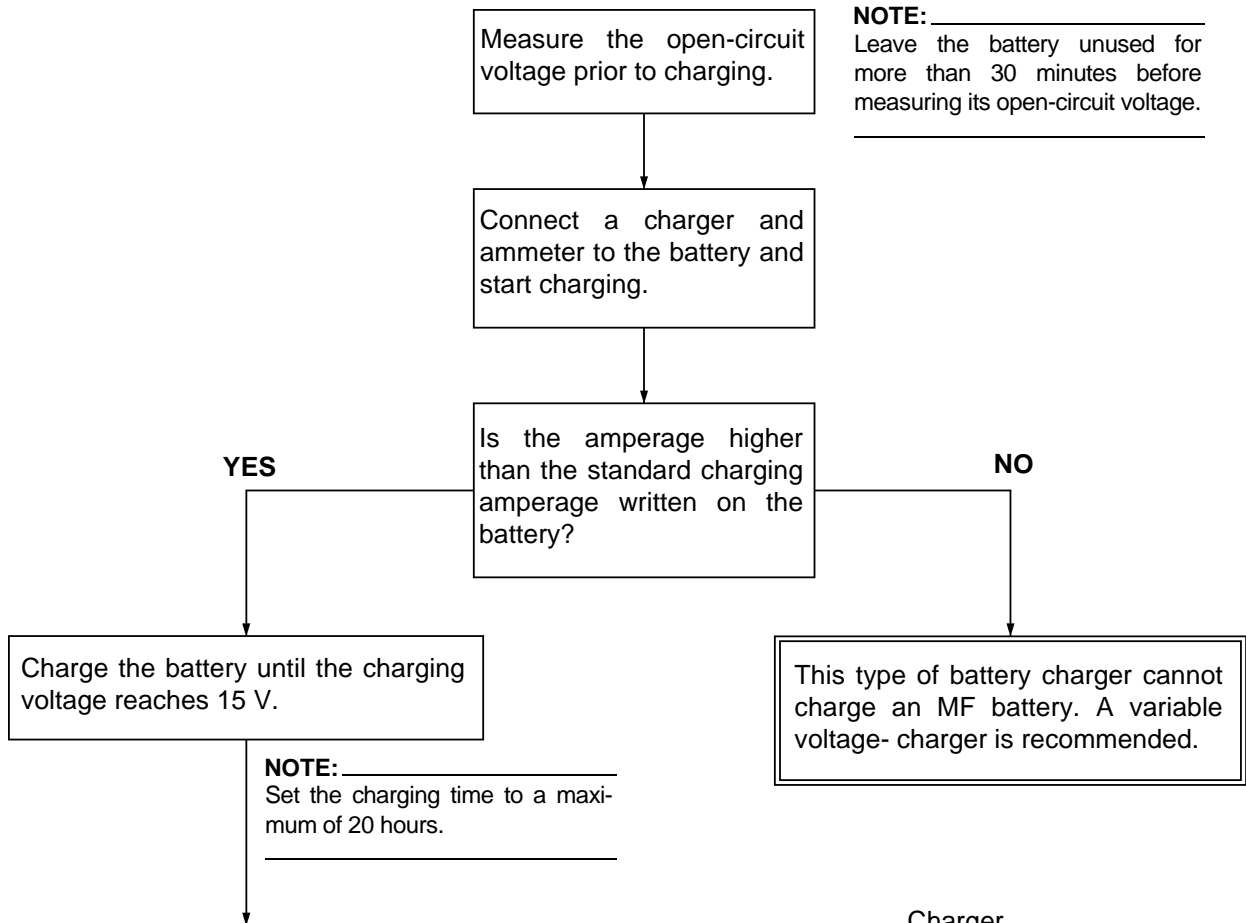

NOTE: _____
 Leave the battery unused for more than 30 minutes before measuring its open-circuit voltage.

NOTE: _____
 Set the charging time to a maximum of 20 hours.

Leave the battery unused for more than 30 minutes before measuring its open-circuit voltage.
 12.8 V → Charging is complete.
 12.0 ~ 12.7 V → Recharging is required.
 Under 12.0 V → Replace the battery.

CAUTION: _____
 Constant amperage chargers are not suitable for charging MF batteries.

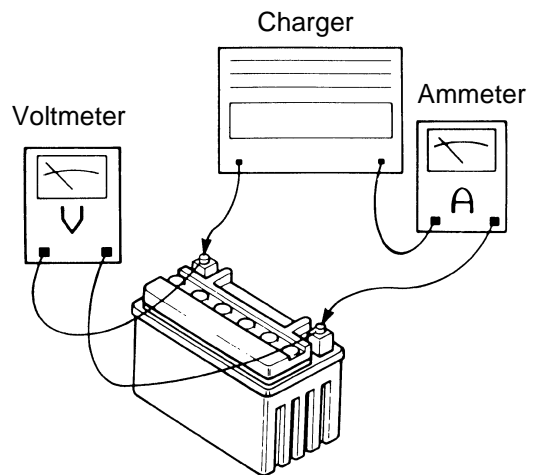

CHECKING THE FUSES



NOTE: _____
Set the pocket tester selector to “ $\Omega \times 1$ ”.

	Pocket tester 90890-03112
---	--------------------------------------

b. If the pocket tester indicates “ ∞ ”, replace the fuse.



3. Replace:
• blown fuse



- a. Set the main switch to “OFF”.
- b. Install a new fuse of the correct amperage.
- c. Set on the switches to verify if the electrical circuit is operational.
- d. If the fuse immediately blows again, check the electrical circuit.

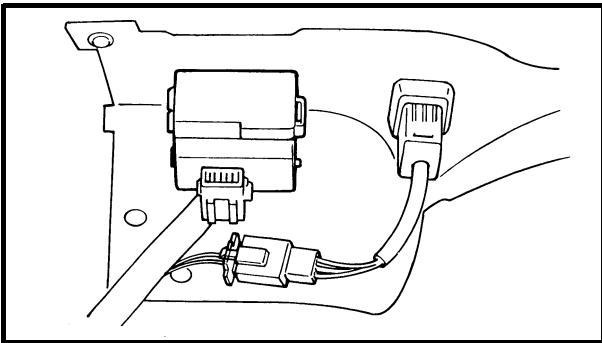
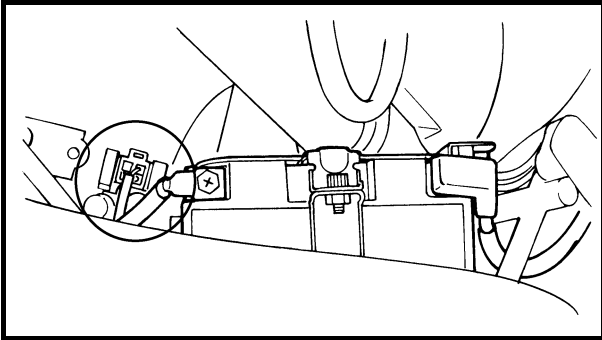

Items	Amperage rating	Q'ty
Main fuse	50 A	1
Headlight fuse	25 A	1
Radiator fan motor fuse	15 A	1
Signaling system fuse	15 A	1
Fuel injection system fuse	15 A	1
Ignition fuse	10 A	1
Parking lighting fuse	10 A	1
Windshield motor fuse	2 A	1
Hazard lighting fuse	7.5 A	1
Backup fuse	10 A	1
Reserve fuse	50 A	1
Reserve fuse	25 A	1
Reserve fuse	15 A	2
Reserve fuse	10 A	1
Reserve fuse	7.5 A	1
Reserve fuse	2 A	1



⚠ WARNING

Never use a fuse with an amperage rating other than that specified. Improvising or using a fuse with the wrong amperage rating may cause extensive damage to the electrical system, cause the lighting and ignition systems to malfunction and could possibly cause a fire.

4. Install:
 - front-right inner panel (front cowling)
 - right inner panel (front cowling)
 - left inner panel (front cowling)Refer to "COWLINGS AND COVERS".

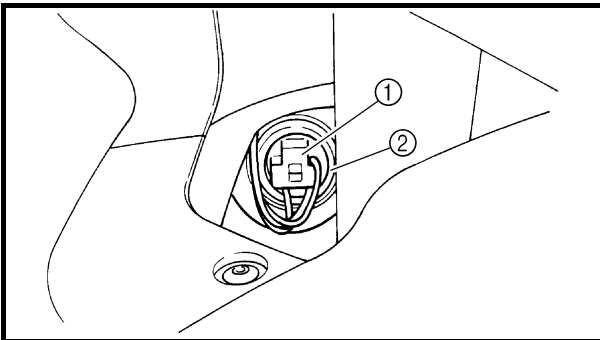

EAS00183

REPLACING THE HEADLIGHT BULBS

The following procedure applies to both of the headlight bulbs.

1. Disconnect:
 - headlight coupler ①
2. Remove:
 - headlight bulb cover ②
3. Detach:
 - headlight bulb holder ①
4. Remove:
 - headlight bulb ②

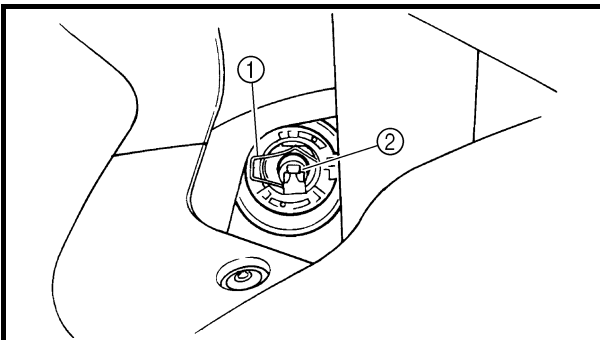

⚠ WARNING

Since the headlight bulb gets extremely hot, keep flammable products and your hands away from the bulb until it has cooled down.

ADJUSTING THE HEADLIGHT BEAMS

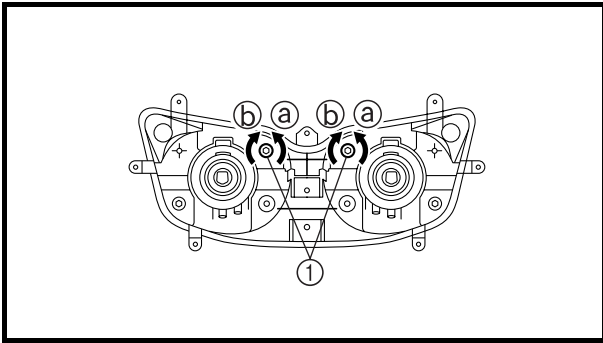

2. Adjust:
- headlight beam (horizontally)



a. Turn the adjusting screw ① in direction ① or ②.

Left headlight

Direction ①	Headlight beam moves to the right.
Direction ②	Headlight beam moves to the left.

Right headlight

Direction ①	Headlight beam moves to the right.
Direction ②	Headlight beam moves to the left.



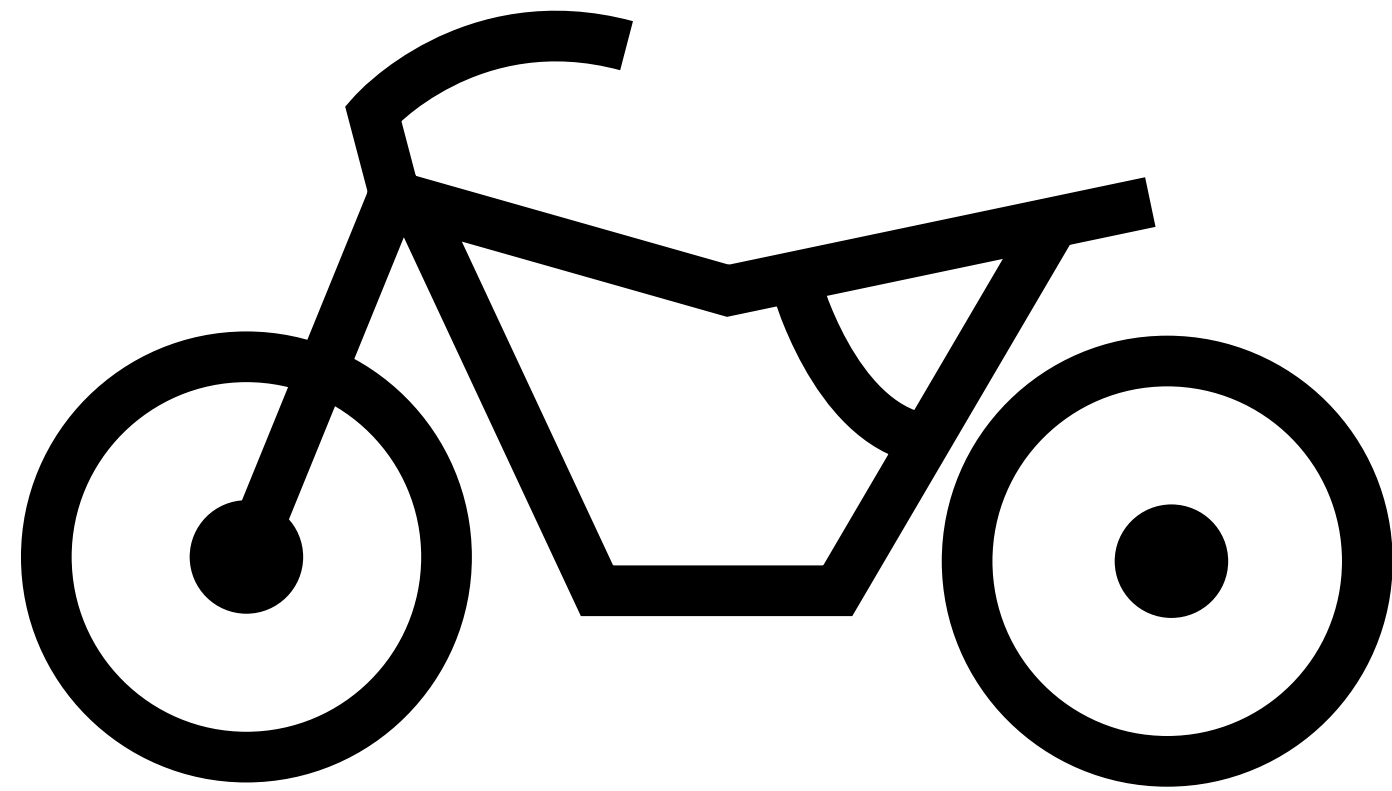

CHAS

4

CHAPTER 4

CHASSIS

FRONT WHEEL AND BRAKE DISCS	4-1
REMOVING THE FRONT WHEEL.....	4-3
CHECKING THE FRONT WHEEL	4-3
CHECKING THE BRAKE DISCS	4-5
INSTALLING THE FRONT WHEEL	4-6
ADJUSTING THE FRONT WHEEL STATIC BALANCE	4-7
REAR WHEEL AND BRAKE DISC	4-9
REMOVING THE REAR WHEEL	4-11
CHECKING THE REAR WHEEL.....	4-11
INSTALLING THE REAR WHEEL.....	4-12
ADJUSTING THE REAR WHEEL STATIC BALANCE.....	4-12
FRONT AND REAR BRAKES	4-13
FRONT BRAKE PADS	4-13
REAR BRAKE PADS.....	4-14
REPLACING THE FRONT BRAKE PADS	4-15
REPLACING THE REAR BRAKE PADS.....	4-17
FRONT BRAKE MASTER CYLINDER	4-20
REAR BRAKE MASTER CYLINDER	4-23
DISASSEMBLING THE FRONT BRAKE MASTER CYLINDER	4-26
DISASSEMBLING THE REAR BRAKE MASTER CYLINDER.....	4-26
CHECKING THE FRONT AND REAR BRAKE MASTER CYLINDERS..	4-27
ASSEMBLING AND INSTALLING	
THE FRONT BRAKE MASTER CYLINDER.....	4-28
ASSEMBLING THE REAR BRAKE MASTER CYLINDER.....	4-30
FRONT BRAKE CALIPERS	4-33
REAR BRAKE CALIPER	4-35
DISASSEMBLING THE FRONT BRAKE CALIPERS.....	4-37
DISASSEMBLING THE REAR BRAKE CALIPER	4-38
CHECKING THE FRONT AND REAR BRAKE CALIPERS	4-39
ASSEMBLING AND INSTALLING THE FRONT BRAKE CALIPERS	4-40
ASSEMBLING AND INSTALLING THE REAR BRAKE CALIPER	4-42
HYDRAULIC CLUTCH	4-46
CLUTCH MASTER CYLINDER.....	4-46
DISASSEMBLING THE CLUTCH MASTER CYLINDER	4-49
CHECKING THE CLUTCH MASTER CYLINDER.....	4-50
ASSEMBLING AND INSTALLING THE CLUTCH	
MASTER CYLINDER	4-51
CLUTCH RELEASE CYLINDER	4-54
DISASSEMBLING THE CLUTCH RELEASE CYLINDER.....	4-56
CHECKING THE CLUTCH RELEASE CYLINDER	4-57
ASSEMBLING AND INSTALLING THE CLUTCH	
RELEASE CYLINDER	4-57

FRONT FORK	4-60
REMOVING THE FRONT FORK LEGS.....	4-63
DISASSEMBLING THE FRONT FORK LEGS.....	4-63
CHECKING THE FRONT FORK LEGS.....	4-65
ASSEMBLING THE FRONT FORK LEGS.....	4-66
INSTALLING THE FRONT FORK LEGS.....	4-70
HANDLEBARS	4-71
LEFT HANDLEBAR.....	4-71
RIGHT HANDLEBAR.....	4-72
REMOVING THE HANDLEBARS.....	4-73
CHECKING THE HANDLEBARS.....	4-73
INSTALLING THE HANDLEBARS.....	4-74
STEERING HEAD	4-77
REMOVING THE LOWER BRACKET.....	4-79
CHECKING THE STEERING HEAD.....	4-79
INSTALLING THE STEERING HEAD.....	4-80
REAR SHOCK ABSORBER ASSEMBLY AND RELAY ARM	4-82
HANDLING THE REAR SHOCK ABSORBER.....	4-84
DISPOSING OF A REAR SHOCK ABSORBER.....	4-84
REMOVING THE REAR SHOCK ABSORBER ASSEMBLY.....	4-84
CHECKING THE REAR SHOCK ABSORBER ASSEMBLY.....	4-85
CHECKING THE CONNECTING ARM AND RELAY ARM.....	4-85
INSTALLING THE RELAY ARM.....	4-86
INSTALLING THE REAR SHOCK ABSORBER ASSEMBLY.....	4-86
SWINGARM	4-87
REMOVING THE SWINGARM.....	4-89
CHECKING THE SWINGARM.....	4-89
INSTALLING THE SWINGARM.....	4-90
SHAFT DRIVE	4-92
TROUBLESHOOTING.....	4-92
CHECKING THE FINAL DRIVE OIL FOR CONTAMINATION AND CHECKING THE SHAFT DRIVE FOR LEAKS.....	4-95
MEASURING THE RING GEAR BACKLASH.....	4-96
ADJUSTING THE RING GEAR BACKLASH.....	4-97
MEASURING THE RING-GEAR-TO-STOPPER-BOLT CLEARANCE ...	4-98
ADJUSTING THE RING-GEAR-TO-STOPPER-BOLT CLEARANCE ...	4-98
REMOVING THE LEFT FOOTREST BRACKET.....	4-104
DISASSEMBLING THE FINAL DRIVE ASSEMBLY.....	4-104
REMOVING AND INSTALLING THE RING GEAR BEARINGS.....	4-105
ALIGNING THE FINAL DRIVE PINION GEAR AND RING GEAR.....	4-107
CHECKING THE DRIVE SHAFT.....	4-112
INSTALLING THE UNIVERSAL JOINT AND FINAL DRIVE ASSEMBLY.....	4-112

EAS00514

CHASSIS

FRONT WHEEL AND BRAKE DISCS

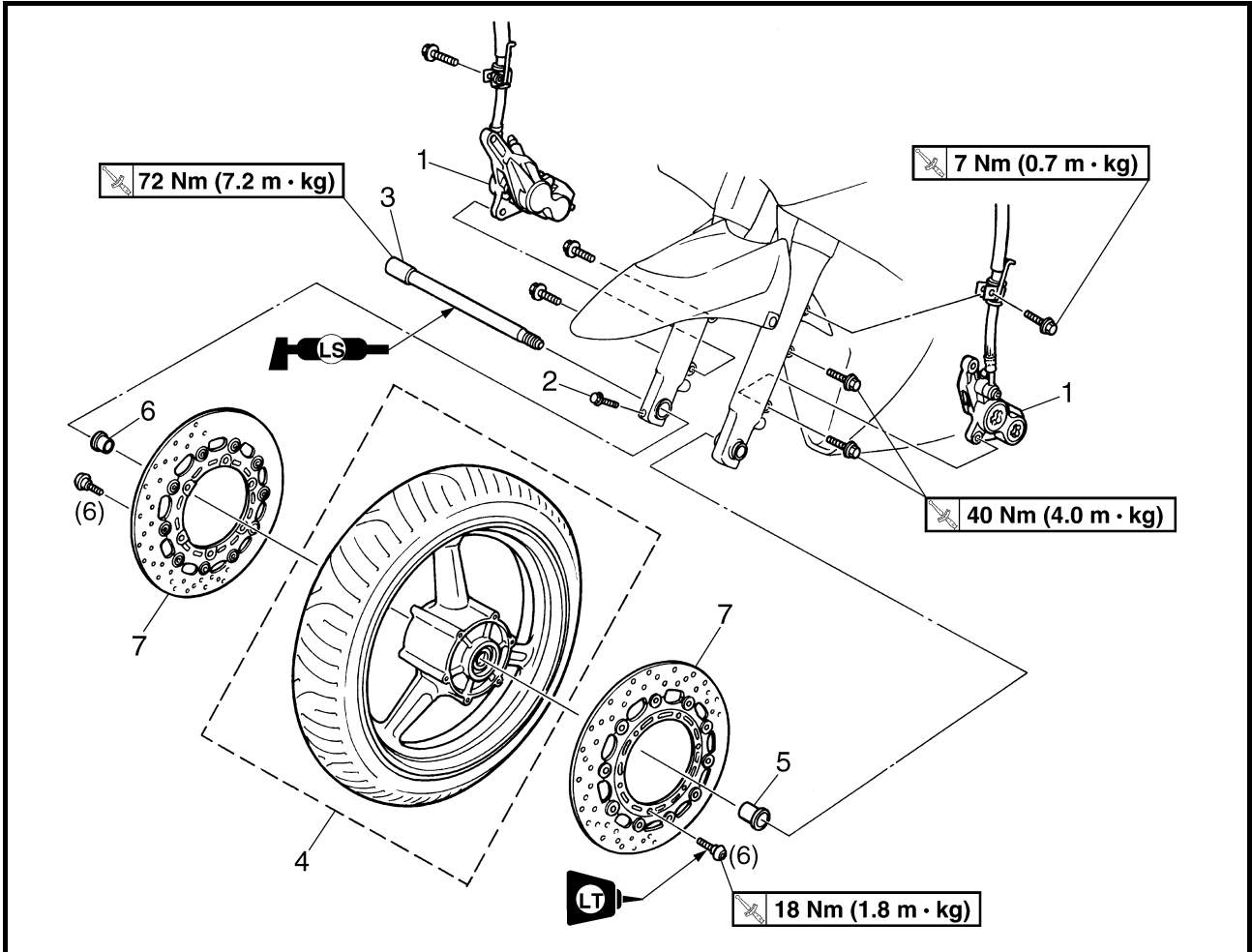

Order	Job/Part	Q'ty	Remarks
	Removing the front wheel and brake discs		Remove the parts in the order listed.
			NOTE: _____ Place the motorcycle on a suitable stand so that the front wheel is elevated.
1	Brake caliper (left and right)	2	Loosen. } Refer to "REMOVING/ INSTALLING THE FRONT WHEEL".
2	Wheel axle pinch bolt	1	
3	Front wheel axle	1	
4	Front wheel	1	
5	Collar (left)	1	
6	Collar (right)	1	
7	Brake disc (left and right)	2	
			For installation, reverse the removal procedure.

EAS00518

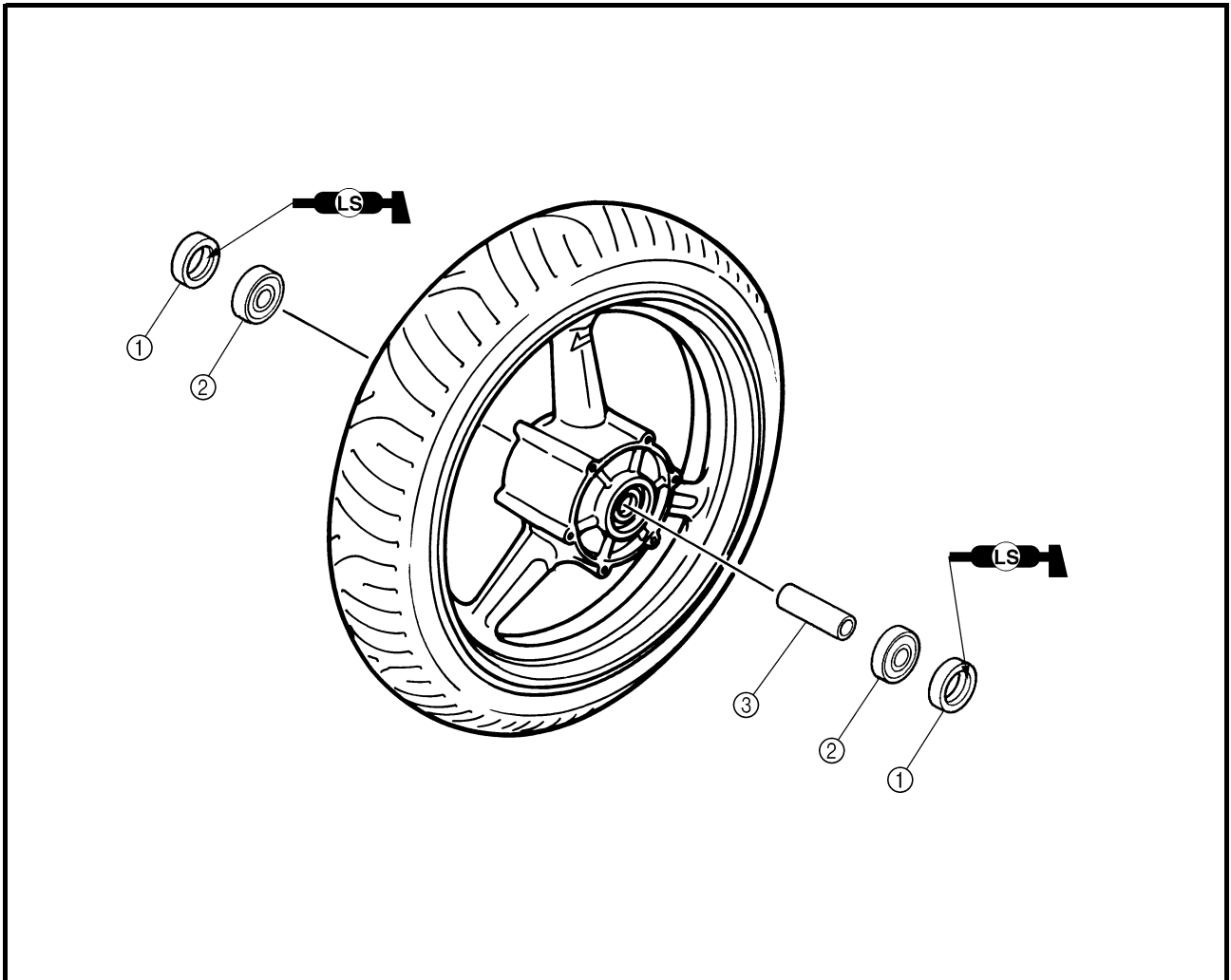

Order	Job/Part	Q'ty	Remarks
	Disassembling the front wheel		Remove the parts in the order listed.
①	Oil seal	2	
②	Wheel bearing	2	
③	Spacer	1	
			For assembly, reverse the disassembly procedure.

EAS00521

REMOVING THE FRONT WHEEL

1. Stand the motorcycle on a level surface.

⚠ WARNING

Securely support the motorcycle so that there is no danger of it falling over.

NOTE:

Place the motorcycle on a suitable stand so that the front wheel is elevated.

2. Remove:

- left brake caliper
- right brake caliper

NOTE:

Do not squeeze the brake lever when removing the brake calipers.

3. Elevate:

- front wheel

NOTE:

Place the motorcycle on a suitable stand so that the front wheel is elevated.

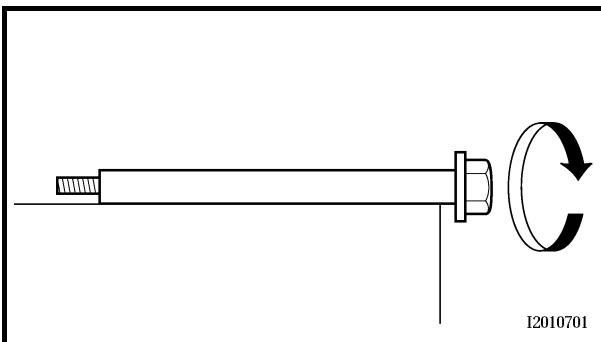

EAS00525

CHECKING THE FRONT WHEEL

1. Check:

- wheel axle
Roll the wheel axle on a flat surface.
Bends → Replace.

⚠ WARNING

Do not attempt to straighten a bent wheel axle.

2. Check:

- tire
- front wheel
Damage/wear → Replace.
Refer to “CHECKING THE TIRES” and “CHECKING THE WHEELS” in chapter 3.

EAS00533

CHECKING THE BRAKE DISCS

The following procedure applies to all of the brake discs.

1. Check:
 - brake disc
Damage/galling → Replace.
2. Measure:
 - brake disc deflection
Out of specification → Correct the brake disc deflection or replace the brake disc.

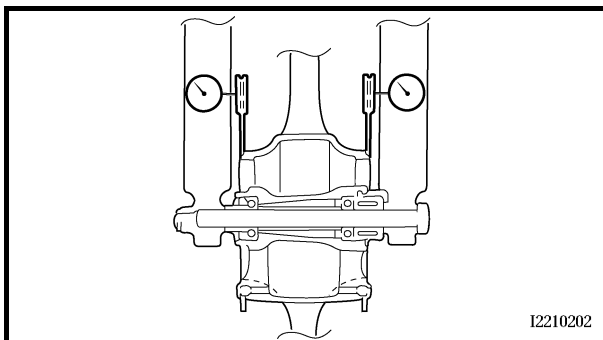

Brake disc deflection limit (maximum)
Front: 0.10 mm
Rear: 0.15 mm

- a. Place the motorcycle on a suitable stand so that the wheel is elevated.
- b. Before measuring the front brake disc deflection, turn the handlebars to the left or right to ensure that the front wheel is stationary.
- c. Remove the brake caliper.
- d. Hold the dial gauge at a right angle against the brake disc surface.
- e. Measure the deflection 1.5 mm below the edge of the brake disc.

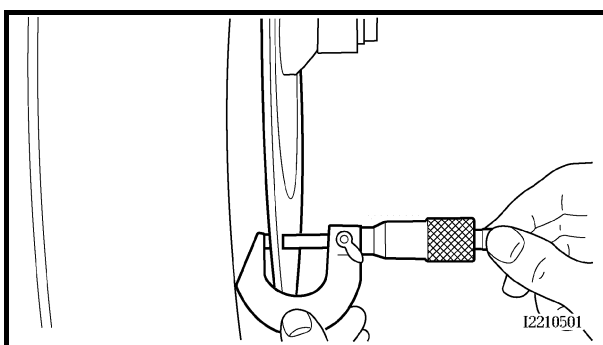

3. Measure:
 - brake disc thickness
Measure the brake disc thickness at a few different locations.
Out of specification → Replace.

Brake disc thickness limit (minimum)
Front: 4.5 mm
Rear: 5.5 mm

EAS00551

REAR WHEEL AND BRAKE DISC

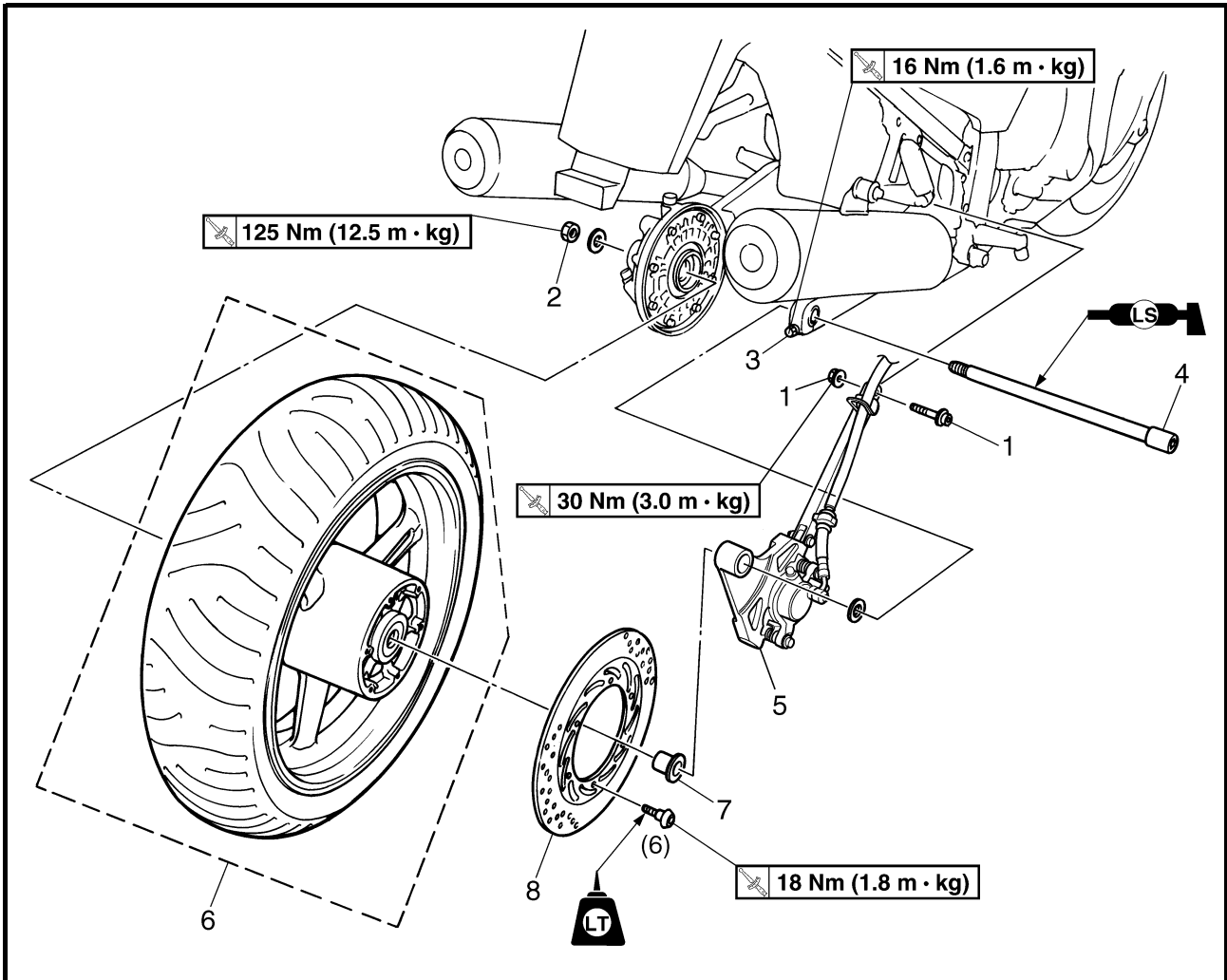

Order	Job/Part	Q'ty	Remarks
	Removing the rear wheel and brake disc		Remove the parts in the order listed.
			NOTE: _____ Place the motorcycle on a suitable stand so that the rear wheel is elevated.
1	Brake torque rod nut/bolt	1/1	Loosen. } Refer to "INSTALLING THE REAR WHEEL".
2	Wheel axle nut	1	
3	Wheel axle pinch bolt	1	
4	Rear wheel axle	1	
5	Rear brake caliper	1	
6	Rear wheel	1	
7	Collar	1	
8	Brake disc	1	
			For installation, reverse the removal procedure.

AS00560

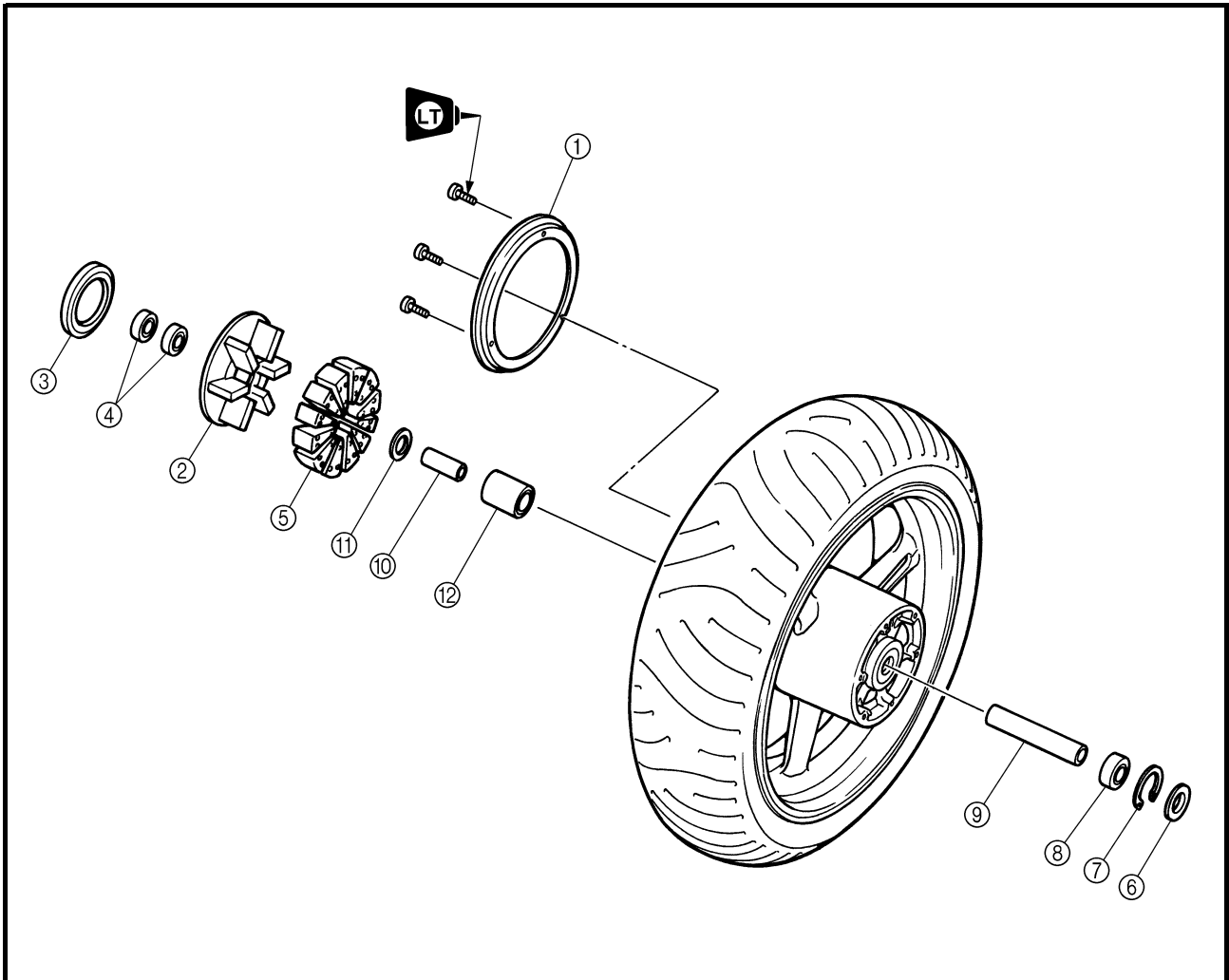

Order	Job/Part	Q'ty	Remarks
	Disassembling the rear wheel		Remove the parts in the order listed.
①	Dust cover	1	
②	Rear wheel drive hub	1	
③	Dust seal	1	
④	Wheel bearing	2	
⑤	Rear wheel drive hub damper	6	
⑥	Oil seal	1	
⑦	Circlip	1	
⑧	Wheel bearing	1	
⑨	Spacer	1	
⑩	Collar	1	
⑪	Oil seal	1	
⑫	Bearing	1	
			For assembly, reverse the disassembly procedure.

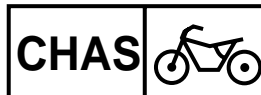

EEAS00562

REMOVING THE REAR WHEEL

1. Stand the motorcycle on a level surface.

⚠ WARNING

Securely support the motorcycle so that there is no danger of it falling over.

NOTE:

Place the motorcycle on a suitable stand so that the rear wheel is elevated.

2. Remove:

- brake caliper bracket

NOTE:

Do not depress the brake pedal when removing the brake caliper bracket with brake caliper.

3. Remove:

- rear wheel

NOTE:

Move the rear wheel to the right to separate it from the final drive housing.

EAS00565

CHECKING THE REAR WHEEL

1. Check:

- wheel axle
- rear wheel
- wheel bearings
- oil seals

Refer to "FRONT WHEEL AND BRAKE DISCS".

2. Check:

- tire
- rear wheel

Damage/wear → Replace.

Refer to "CHECKING THE TIRES" and "CHECKING THE WHEELS" in chapter 3.

3. Measure:

- radial wheel runout
- lateral wheel runout

Refer to “FRONT WHEEL AND BRAKE DISCS”.

EEAS00572

INSTALLING THE REAR WHEEL

1. Lubricate:

- wheel axle
- wheel bearings
- oil seal lips

	Recommended lubricant Lithium soap base grease
---	--

2. Tighten:

- brake torque rod nut

	30 Nm (3.0 m · kg)
---	---------------------------

- wheel axle nut

	125 Nm (12.5 m · kg)
---	-----------------------------

- wheel axle pinch bolt

	16 Nm (1.6 m · kg)
---	---------------------------

EAS00575

ADJUSTING THE REAR WHEEL STATIC BALANCE

NOTE: _____

- After replacing the tire, wheel or both, the rear wheel static balance should be adjusted.
- Adjust the rear wheel static balance with the brake disc and rear wheel drive hub installed.

1. Adjust:

- rear wheel static balance

Refer to “FRONT WHEEL AND BRAKE DISCS”.

EAS00577

FRONT AND REAR BRAKES

FRONT BRAKE PADS

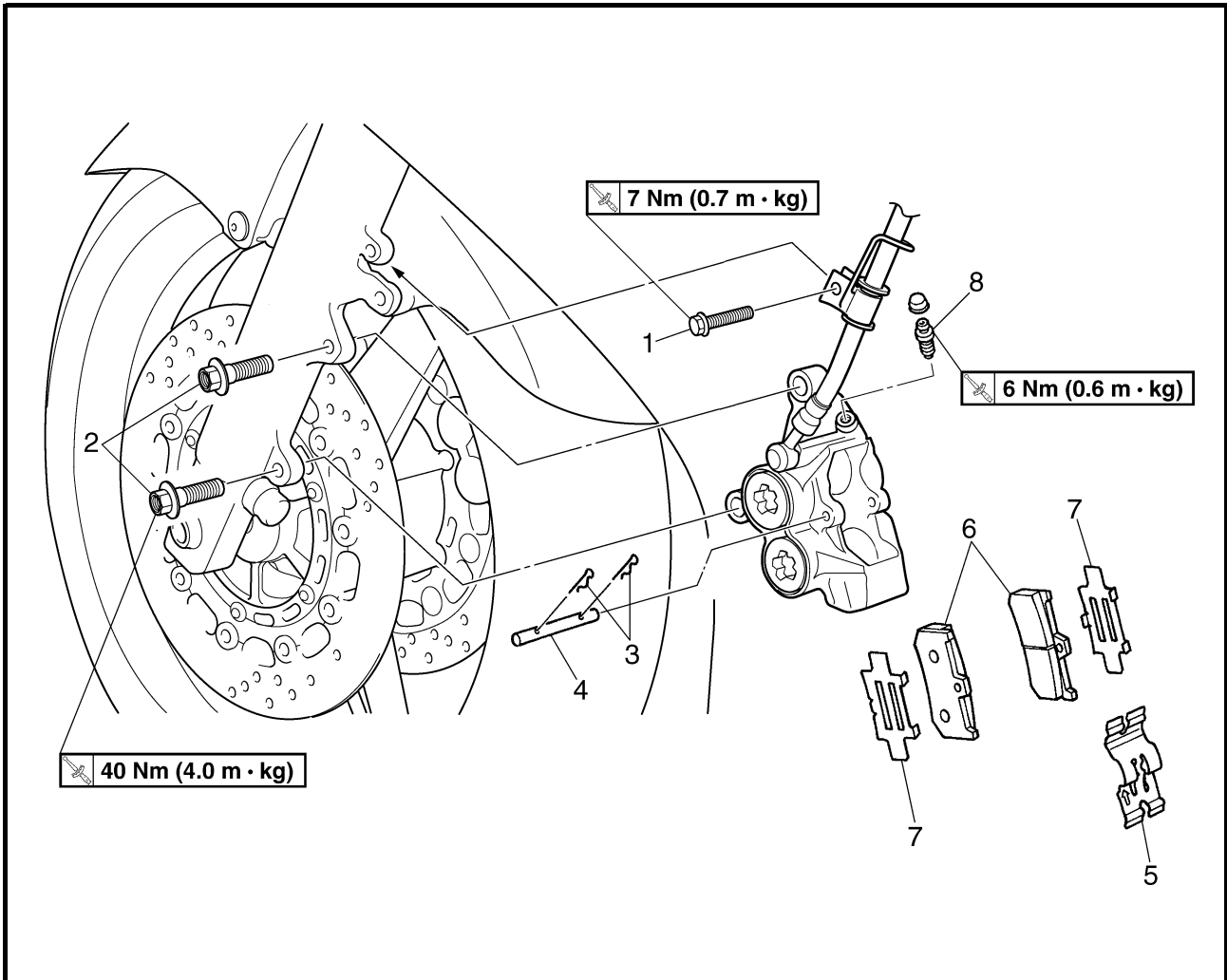

Order	Job/Part	Q'ty	Remarks
	Removing the front brake pads		Remove the parts in the order listed. The following procedure applies to both of the front brake calipers.
1	Brake hose holder bolt	1	
2	Brake caliper bolt	2	
3	Brake pad clip	2	
4	Brake pad pin	1	
5	Brake pad spring	1	
6	Brake pad	2	
7	Brake pad shim	2	
8	Bleed screw	1	
			For installation, reverse the removal procedure.

EAS00578

REAR BRAKE PADS

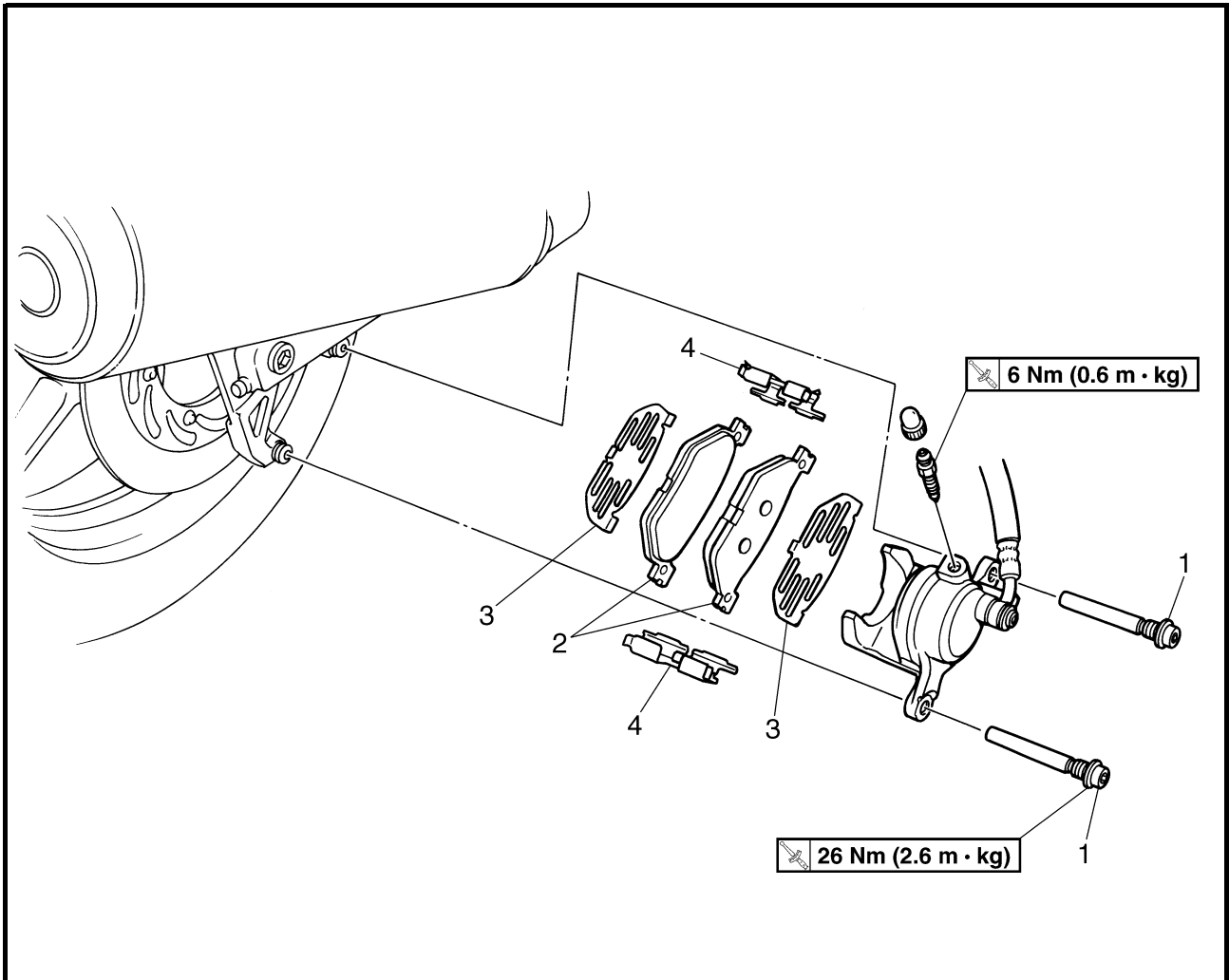

Order	Job/Part	Q'ty	Remarks
	Removing the rear brake pads		Remove the parts in the order listed.
1	Retaining bolt	2	
2	Brake pad	2	
3	Brake pad shim	2	
4	Bleed screw	1	
			For installation, reverse the removal procedure.

EAS00579

CAUTION:

Disc brake components rarely require disassembly.

Therefore, always follow these preventive measures:

- Never disassemble brake components unless absolutely necessary.
- If any connection on the hydraulic brake system is disconnected, the entire brake system must be disassembled, drained, cleaned, properly filled, and bled after reassembly.
- Never use solvents on internal brake components.
- Use only clean or new brake fluid for cleaning brake components.
- Brake fluid may damage painted surfaces and plastic parts. Therefore, always clean up any spilt brake fluid immediately.
- Avoid brake fluid coming into contact with the eyes as it can cause serious injury.

FIRST AID FOR BRAKE FLUID ENTERING THE EYES:

- Flush with water for 15 minutes and get immediate medical attention.

EAS00582

REPLACING THE FRONT BRAKE PADS

The following procedure applies to both brake calipers.

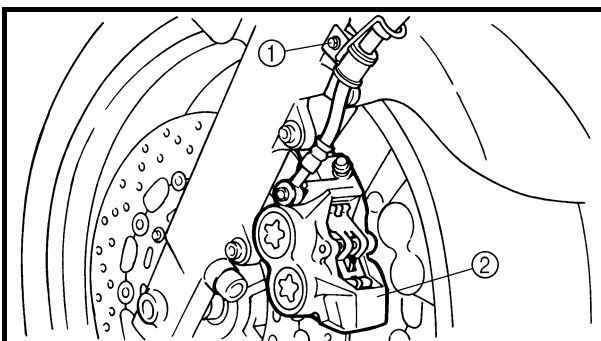

NOTE:

When replacing the brake pads, it is not necessary to disconnect the brake hose or disassemble the brake caliper.

**1. Remove:**

- brake hose holder bolt ①
- brake caliper ②

5. Install:
- brake pad pins
 - brake pad clips
 - brake caliper
 - brake hose holder

	40 Nm (4.0 m · kg)
	7 Nm (0.7 m · kg)

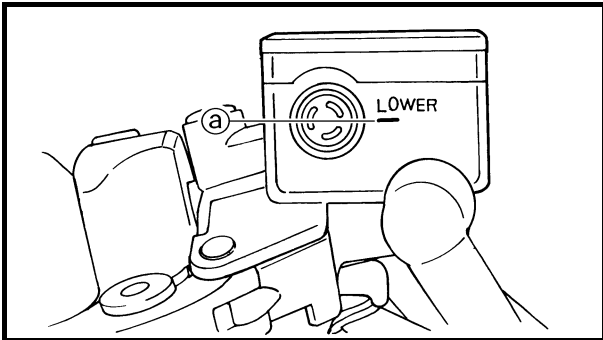

6. Check:
- brake fluid level
Below the minimum level mark (a) → Add the recommended brake fluid to the proper level.
Refer to “CHECKING THE BRAKE FLUID LEVEL” in chapter 3.

7. Check:
- brake lever operation
Soft or spongy feeling → Bleed the brake system.
Refer to “BLEEDING THE HYDRAULIC BRAKE SYSTEM” in chapter 3.

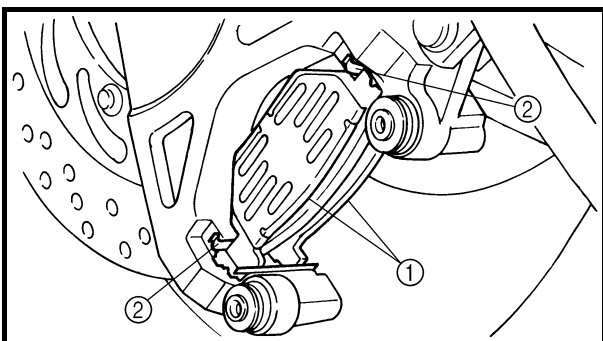
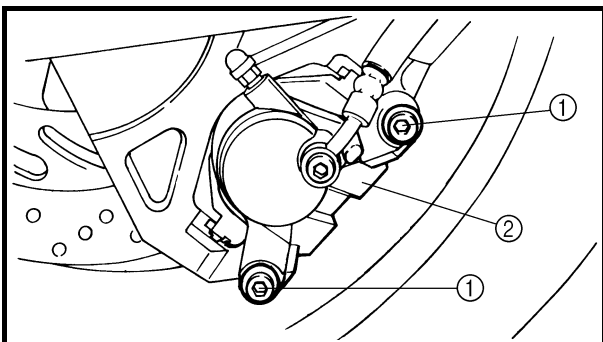

EAS00583

REPLACING THE REAR BRAKE PADS

NOTE:

When replacing the brake pads, it is not necessary to disconnect the brake hose or disassemble the brake caliper.

1. Remove:
- retaining bolts ①
 - brake caliper ②
2. Remove:
- brake pads ①
(along with the brake pad shims)
 - brake pad springs ②

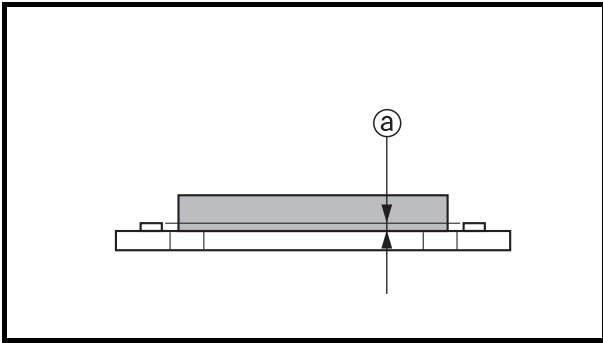

3. Measure:

- brake pad wear limit (a)
- Out of specification → Replace the brake pads as a set.

	Brake pad wear limit 0.8 mm
---	--

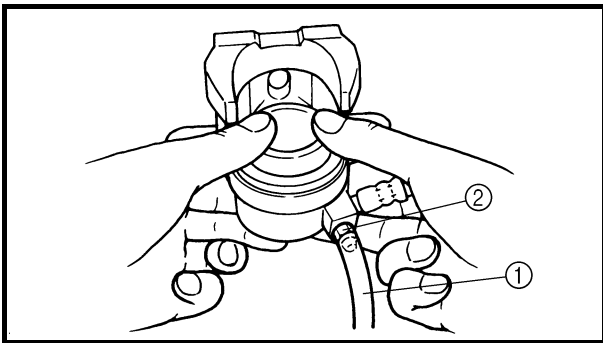

4. Install:

- brake pad springs
- brake pad shims (onto the brake pads)
- brake pads

NOTE:

Always install new brake pads, brake pad shims, and a brake pad spring as a set.

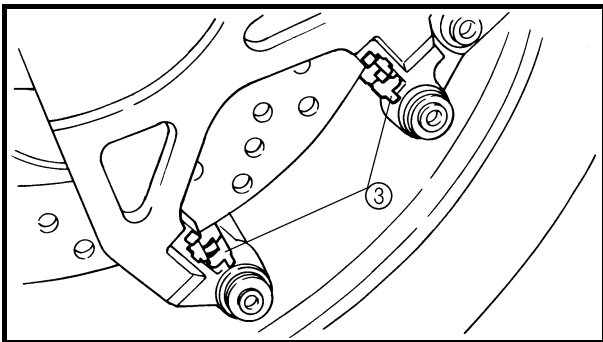

- Connect a clear plastic hose (1) tightly to the bleed screw (2). Put the other end of the hose into an open container.
- Loosen the bleed screw and push the brake caliper piston into the brake caliper with your finger.
- Tighten the bleed screw.

	Bleed screw 6 Nm (0.6 m · kg)
---	--

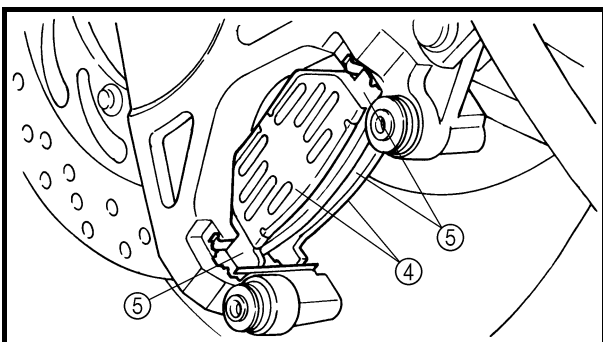

- Install new brake pad springs (3).
- Install a new brake pad shim (4) onto each new brake pad (5).
- Install new brake pads.



5. Install:

- retaining bolts

	26 Nm (2.6 m · kg)
---	---------------------------

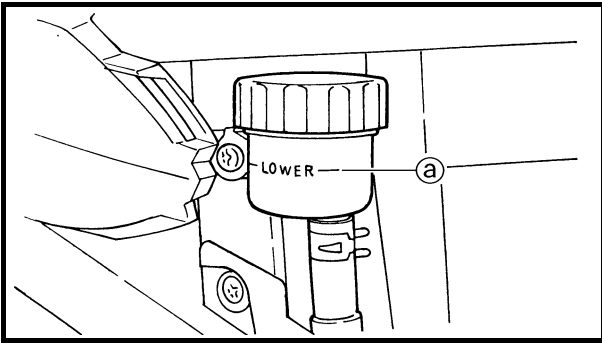

6. Check:
- brake fluid level
Below the minimum level mark (a) → Add the recommended brake fluid to the proper level.
Refer to “CHECKING THE BRAKE FLUID LEVEL” in chapter 3.

7. Check:
- brake pedal operation
Soft or spongy feeling → Bleed the brake system.
Refer to “BLEEDING THE HYDRAULIC BRAKE SYSTEM” in chapter 3.

EAS00584

FRONT BRAKE MASTER CYLINDER

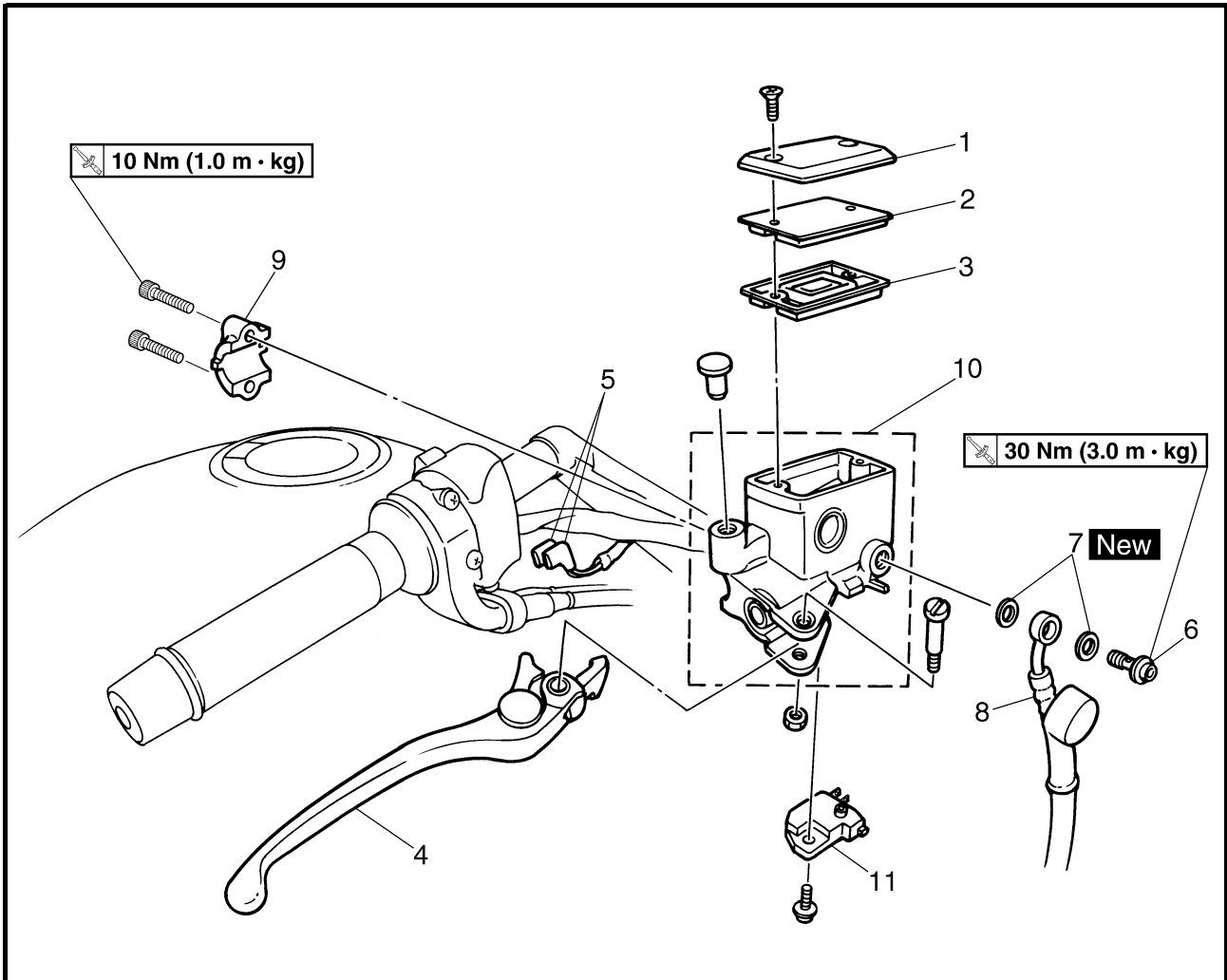

Order	Job/Part	Q'ty	Remarks
	Removing the front brake master cylinder		Remove the parts in the order listed.
	Brake fluid		Drain.
1	Brake master cylinder reservoir cap	1	
2	Brake master cylinder reservoir diaphragm holder	1	
3	Brake master cylinder reservoir diaphragm	1	
4	Brake lever	1	
5	Front brake light switch connector	2	Disconnect.

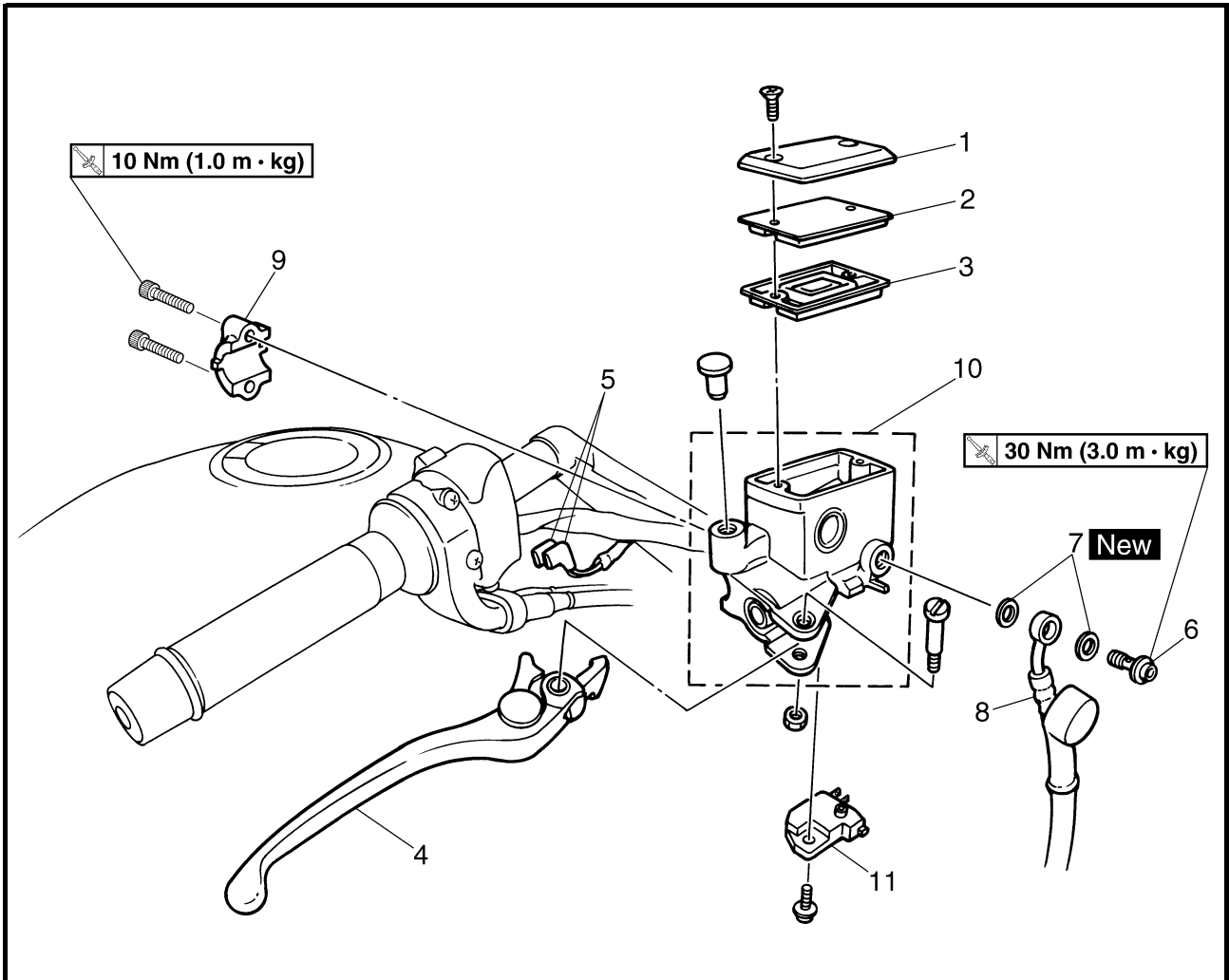

Order	Job/Part	Q'ty	Remarks
6	Union bolt	1	Disconnect. Refer to "DISASSEMBLING/ ASSEMBLING AND INSTALLING THE FRONT BRAKE MASTER CYLINDER".
7	Copper washer	2	
8	Brake hose	1	
9	Brake master cylinder holder	1	
10	Brake master cylinder	1	
11	Front brake light switch	1	For installation, reverse the removal procedure.

EAS00585

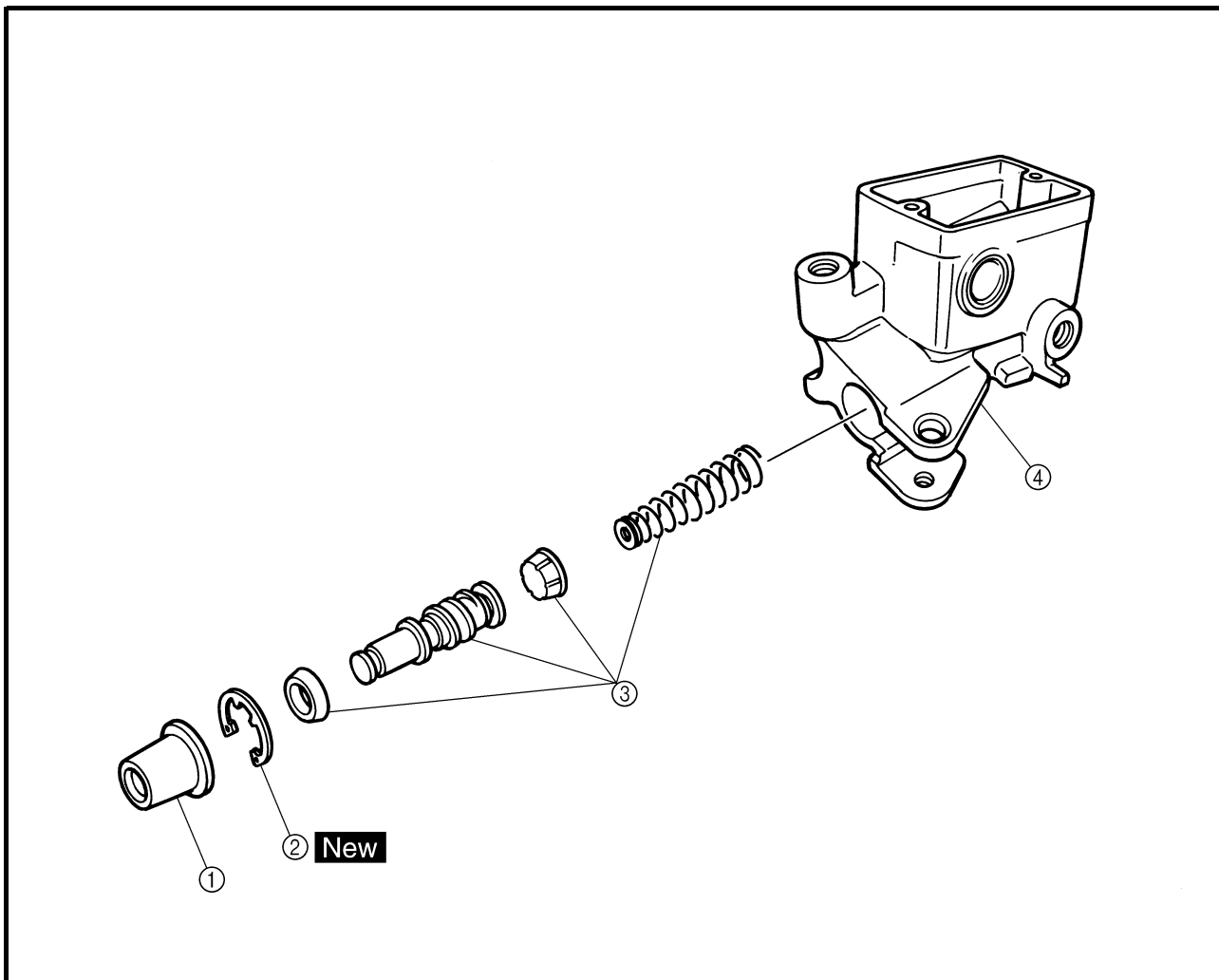

Order	Job/Part	Q'ty	Remarks
	Disassembling the front brake master cylinder		Remove the parts in the order listed.
①	Dust boot	1	
②	Circlip	1	
③	Brake master cylinder kit	1	
④	Brake master cylinder	1	
			For assembly, reverse the disassembly procedure.

EAS00586

REAR BRAKE MASTER CYLINDER

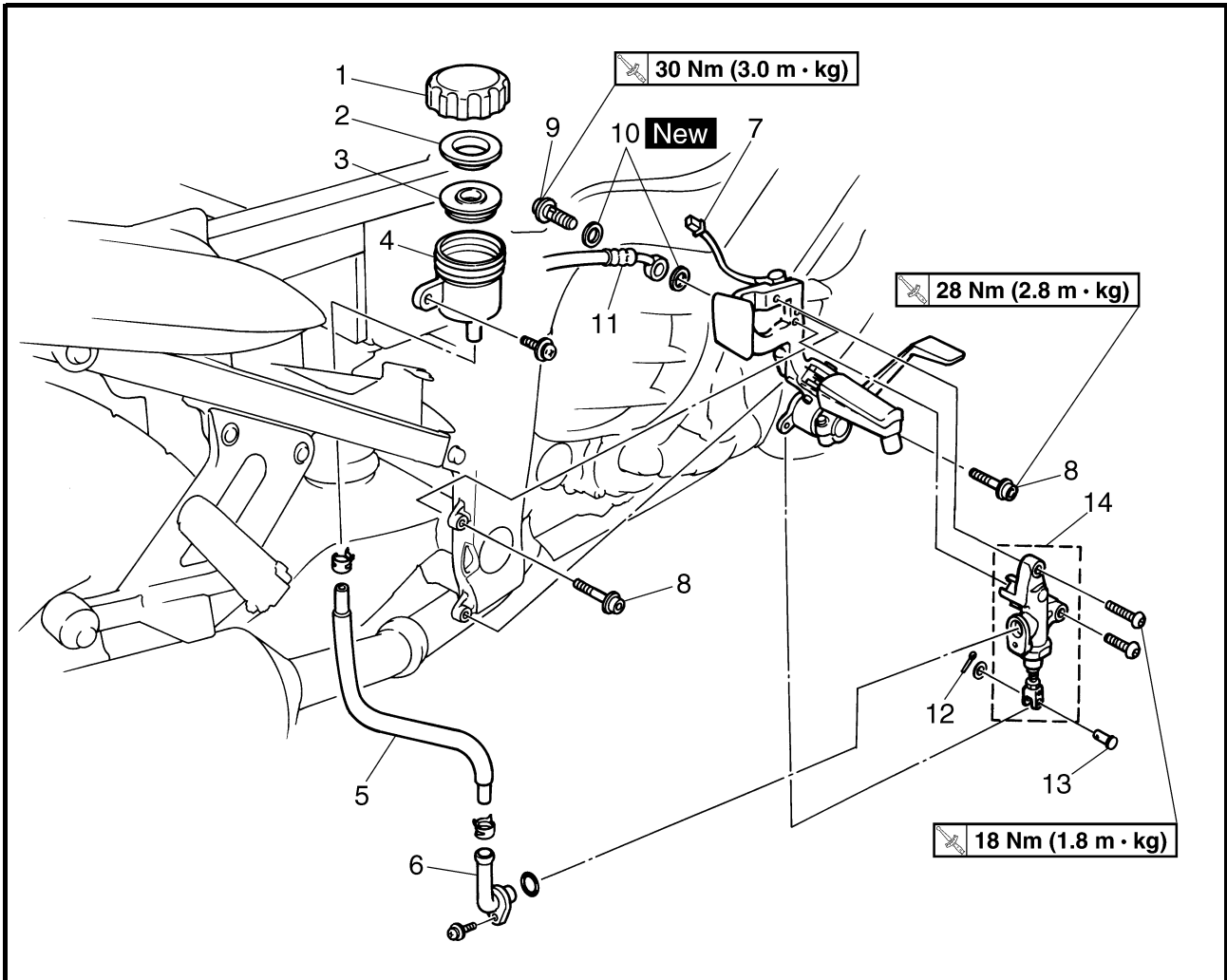

Order	Job/Part	Q'ty	Remarks
	Removing the rear brake master cylinder		Remove the parts in the order listed.
	Side cover (right)		Refer to "COWLINGS AND COVERS" in chapter 3.
	Brake fluid		Drain.
1	Brake fluid reservoir cap	1	
2	Brake fluid reservoir diaphragm holder	1	
3	Brake fluid reservoir diaphragm	1	
4	Brake fluid reservoir	1	
5	Brake fluid reservoir hose	1	
6	Hose joint	1	
7	Rear brake light switch coupler	1	Disconnect.
8	Right footrest bracket bolt	2	

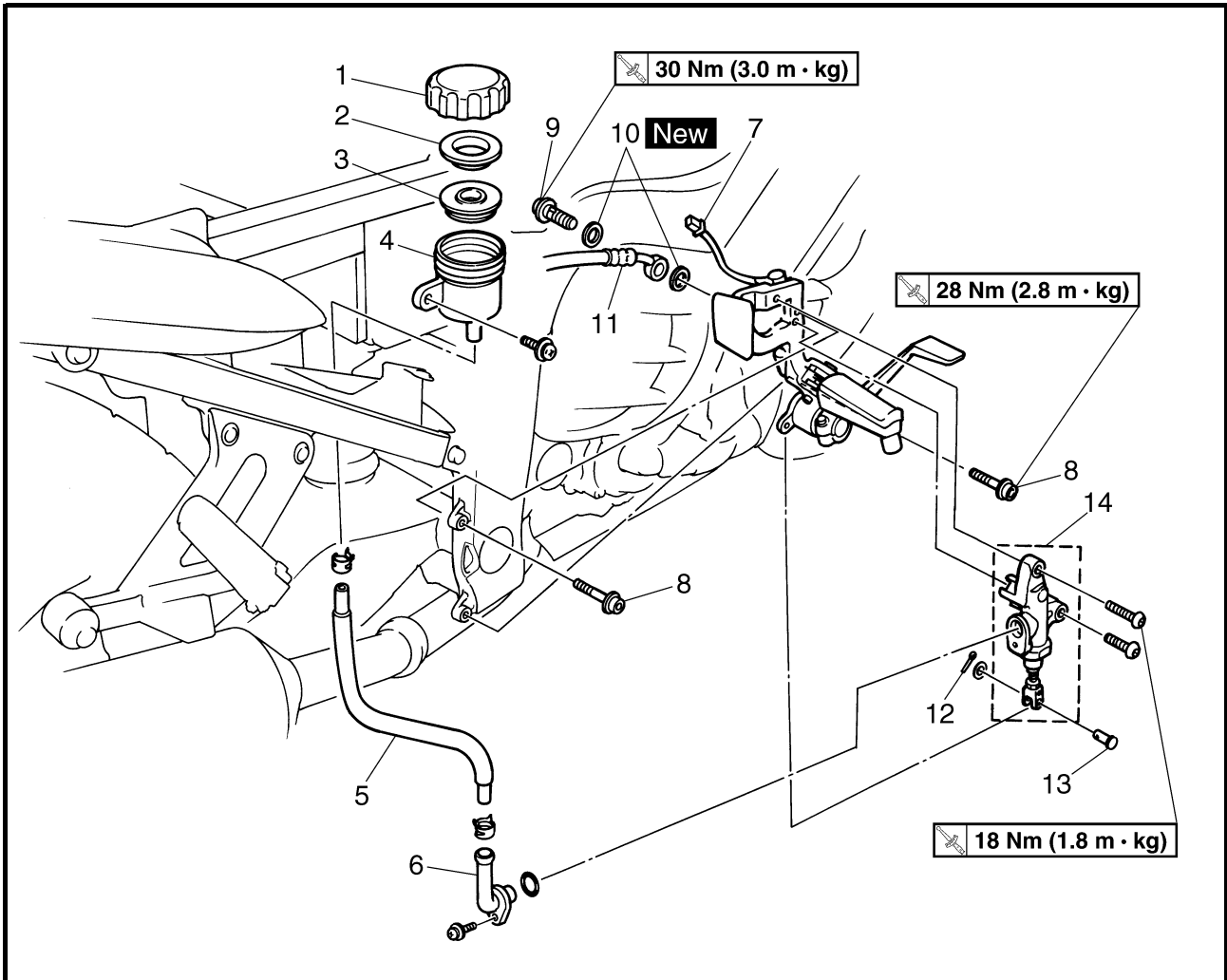

Order	Job/Part	Q'ty	Remarks
9	Union bolt	1	Disconnect. } Refer to "DISASSEMBLING/ ASSEMBLING THE REAR BRAKE MASTER CYLINDER".
10	Copper washer	2	
11	Brake hose	1	
12	Cotter pin	1	For installation, reverse the removal procedure.
13	Pin	1	
14	Brake master cylinder	1	

EAS00587

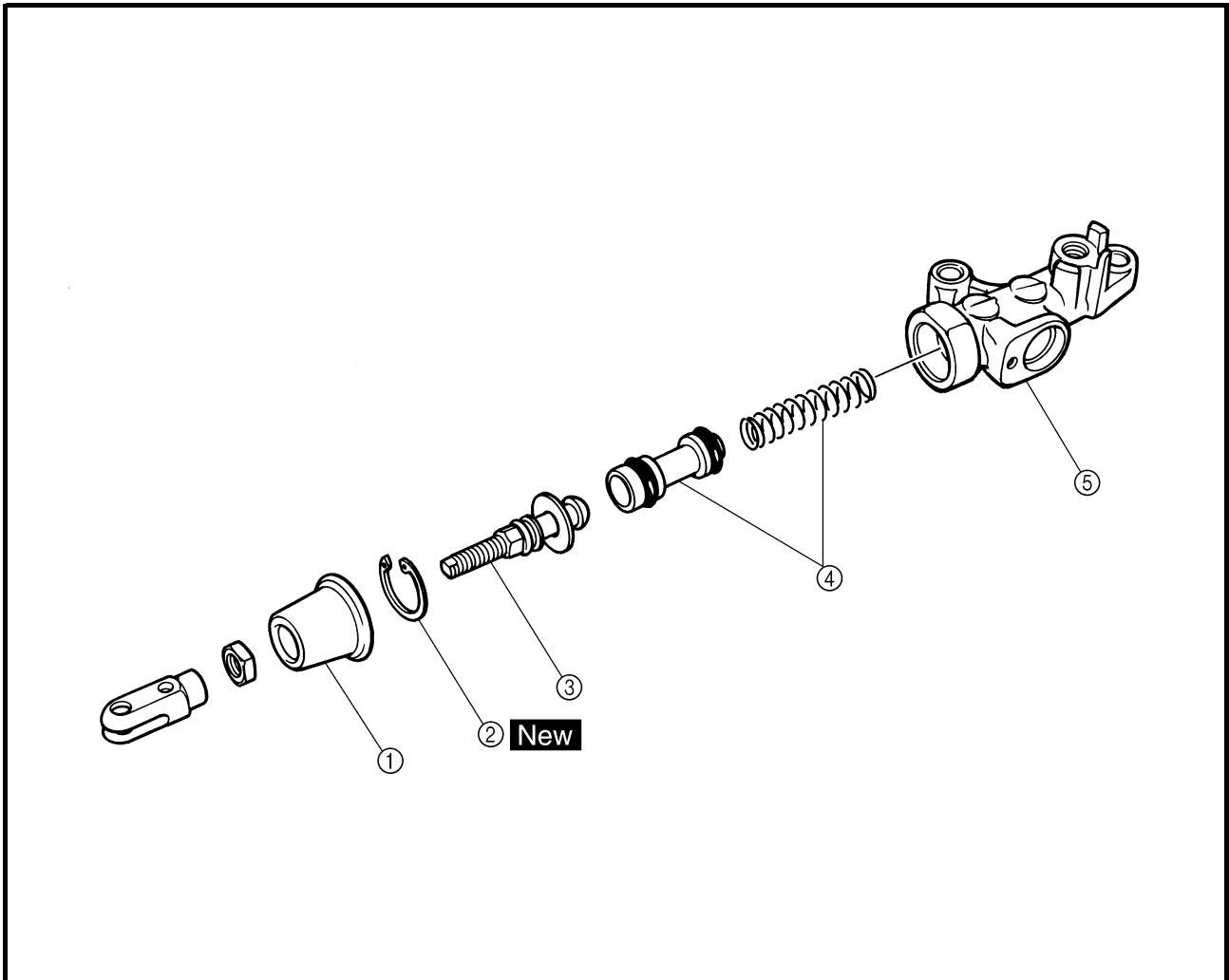

Order	Job/Part	Q'ty	Remarks
	Disassembling the rear brake master cylinder		Remove the parts in the order listed.
①	Dust boot	1	
②	Circlip	1	
③	Push rod	1	
④	Brake master cylinder kit	1	
⑤	Brake master cylinder	1	
			For assembly, reverse the disassembly procedure.

EAS00588

DISASSEMBLING THE FRONT BRAKE MASTER CYLINDER

NOTE: _____

Before disassembling the front brake master cylinder, drain the brake fluid from the entire brake system.

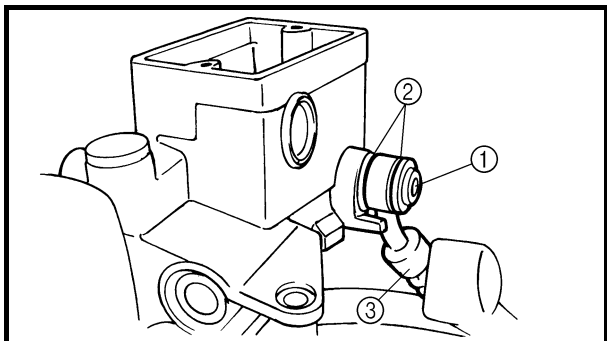

1. Remove:

- union bolt ①
- copper washers ②
- brake hose ③

NOTE: _____

To collect any remaining brake fluid, place a container under the master cylinder and the end of the brake hose.

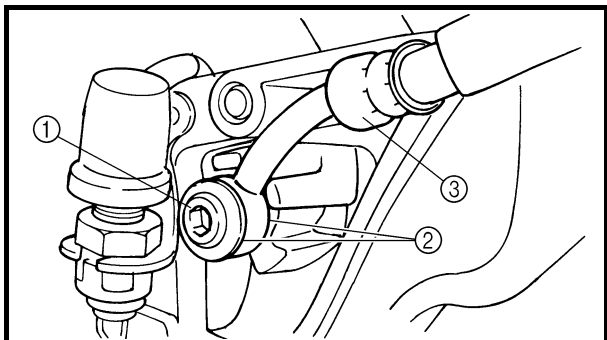

EAS00589

DISASSEMBLING THE REAR BRAKE MASTER CYLINDER

1. Remove:

- union bolt ①
- copper washers ②
- brake hose ③

NOTE: _____

To collect any remaining brake fluid, place a container under the master cylinder and the end of the brake hose.

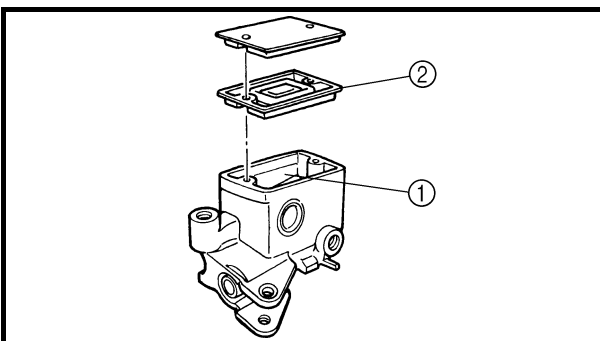
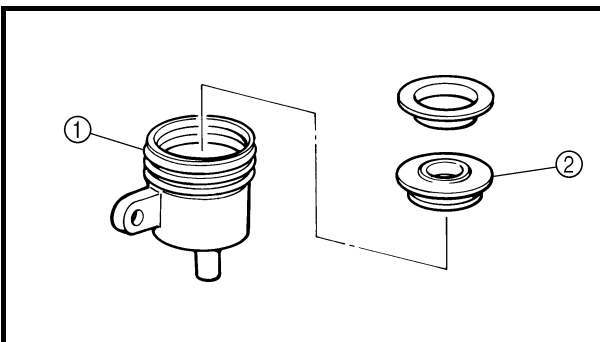
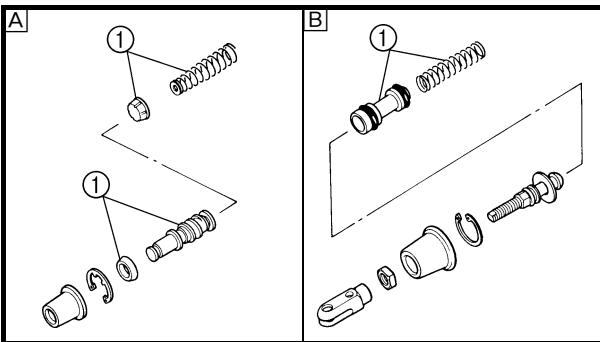
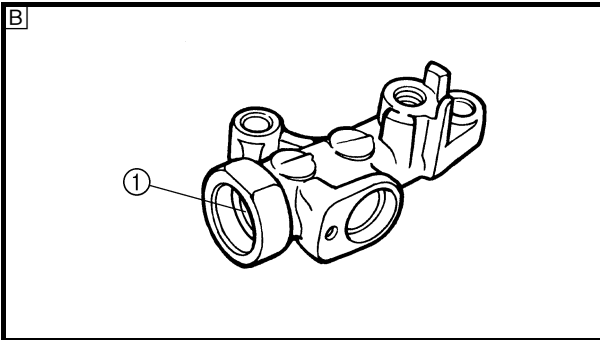
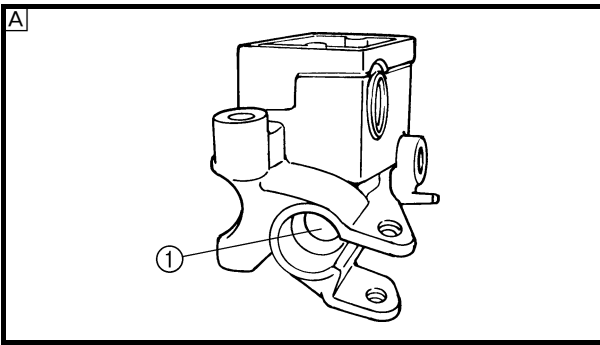

EAS00592

CHECKING THE FRONT AND REAR BRAKE MASTER CYLINDERS

The following procedure applies to the both of the brake master cylinders.

1. Check:

- brake master cylinder ①
Damage/scratches/wear → Replace.
- brake fluid delivery passages (brake master cylinder body)
Obstruction → Blow out with compressed air.

Ⓐ Front

Ⓑ Rear

2. Check:

- brake master cylinder kit ①
Damage/scratches/wear → Replace.

Ⓐ Front

Ⓑ Rear

3. Check:

- rear brake fluid reservoir ①
Cracks/damage → Replace.
- rear brake fluid reservoir diaphragm ②
Cracks/damage → Replace.

4. Check:

- front brake master cylinder reservoir ①
Cracks/damage → Replace.
- front brake master cylinder reservoir diaphragm ②
Damage/wear → Replace.

5. Check:
 - brake hoses
Cracks/damage/wear → Replace.

EAS00606

ASSEMBLING AND INSTALLING THE FRONT BRAKE MASTER CYLINDER

⚠ WARNING

- Before installation, all internal brake components should be cleaned and lubricated with clean or new brake fluid.
- Never use solvents on internal brake components.

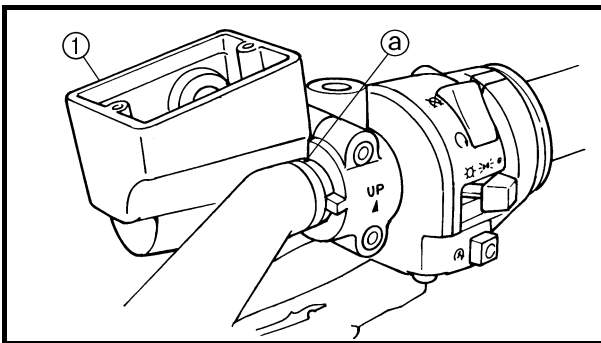

**Recommended brake fluid
DOT 4**

1. Install:
 - brake master cylinder (1)

10 Nm (1.0 m · kg)

NOTE:

- Install the brake master cylinder holder with the “UP” mark facing up.
- Align the end of the brake master cylinder holder with the punch mark (a) in the right handlebar.
- First, tighten the upper bolt, then the lower bolt.

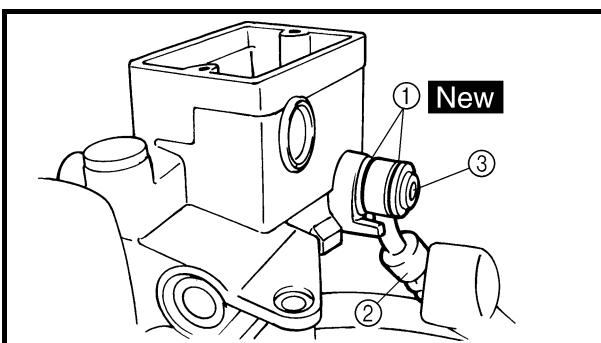

2. Install:
 - copper washers (1) **New**
 - brake hose (2)
 - union bolt (3)

30 Nm (3.0 m · kg)

⚠ WARNING

Proper brake hose routing is essential to insure safe motorcycle operation. Refer to “CABLE ROUTING”.

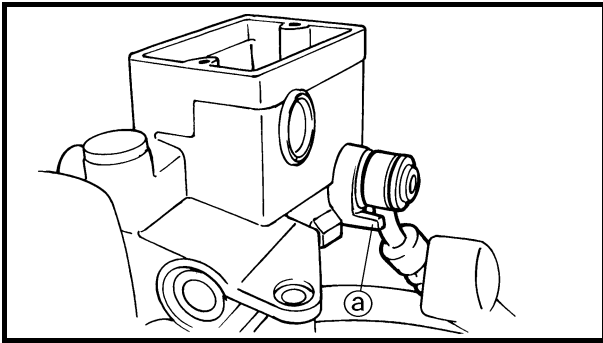
**CAUTION:**

When installing the brake hose onto the brake master cylinder, make sure the brake pipe touches the projection (a) as shown.

NOTE:

Turn the handlebars to the left and to the right to make sure the brake hose does not touch other parts (e.g., wire harness, cables, leads). Correct if necessary.

3. Fill:

- brake master cylinder reservoir (with the specified amount of the recommended brake fluid)



Recommended brake fluid
DOT 4

⚠ WARNING

- Use only the designated brake fluid. Other brake fluids may cause the rubber seals to deteriorate, causing leakage and poor brake performance.
- Refill with the same type of brake fluid that is already in the system. Mixing brake fluids may result in a harmful chemical reaction, leading to poor brake performance.
- When refilling, be careful that water does not enter the brake master cylinder reservoir. Water will significantly lower the boiling point of the brake fluid and could cause vapor lock.

CAUTION:

Brake fluid may damage painted surfaces and plastic parts. Therefore, always clean up any spilled brake fluid immediately.

4. Bleed:

- brake system
Refer to "BLEEDING THE HYDRAULIC BRAKE SYSTEM" in chapter 3.

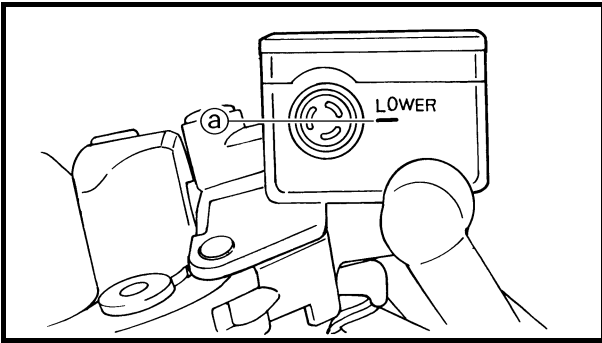

5. Check:
 - brake fluid level
Below the minimum level mark (a) → Add the recommended brake fluid to the proper level.
Refer to “CHECKING THE BRAKE FLUID LEVEL” in chapter 3.

6. Check:
 - brake lever operation
Soft or spongy feeling → Bleed the brake system.
Refer to “BLEEDING THE HYDRAULIC BRAKE SYSTEM” in chapter 3.

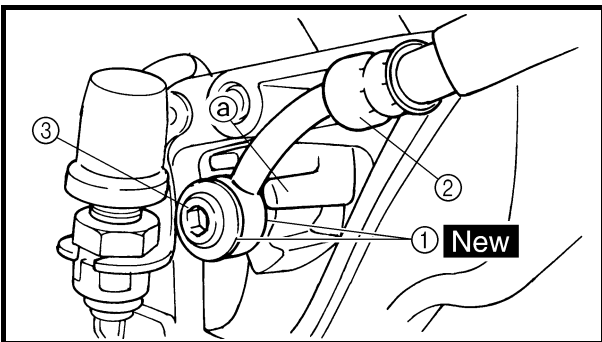

EAS00608

ASSEMBLING THE REAR BRAKE MASTER CYLINDER

1. Install:
 - copper washers ① **New**
 - brake hose ②
 - union bolt ③

 **30 Nm (3.0 m · kg)**

⚠ WARNING

Proper brake hose routing is essential to insure safe motorcycle operation. Refer to “CABLE ROUTING”.

CAUTION:

When installing the brake hose onto the brake master cylinder, make sure the brake pipe touches the projection (a) as shown.

2. Fill:
 - brake fluid reservoir
(with the specified amount of the recommended brake fluid)

	Recommended brake fluid DOT 4
---	--

⚠ WARNING

- Use only the designated brake fluid. Other brake fluids may cause the rubber seals to deteriorate, causing leakage and poor brake performance.
- Refill with the same type of brake fluid that is already in the system. Mixing brake fluids may result in a harmful chemical reaction, leading to poor brake performance.
- When refilling, be careful that water does not enter the brake fluid reservoir. Water will significantly lower the boiling point of the brake fluid and could cause vapor lock.

CAUTION:

Brake fluid may damage painted surfaces and plastic parts. Therefore, always clean up any spilled brake fluid immediately.

3. Bleed:
 - brake system
Refer to “BLEEDING THE HYDRAULIC BRAKE SYSTEM” in chapter 3.

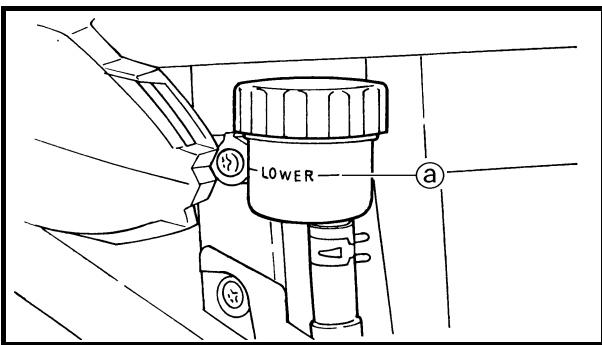

4. Check:
 - brake fluid level
Below the minimum level mark (a) → Add the recommended brake fluid to the proper level.
Refer to “CHECKING THE BRAKE FLUID LEVEL” in chapter 3.

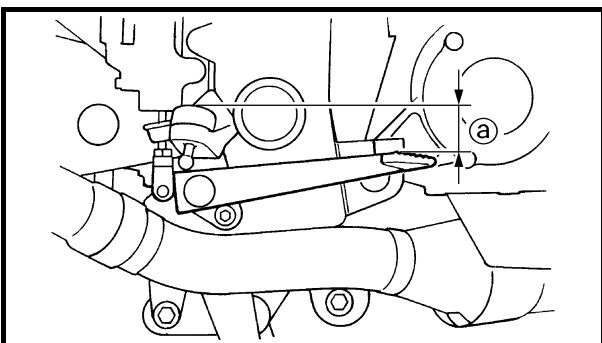

5. Adjust:
 - brake pedal position (a)
Refer to “ADJUSTING THE REAR BRAKE” in chapter 3.

 Brake pedal position (below the top of the rider footrest)
42 mm



6. Adjust:

- rear brake light operation timing

Refer to “ADJUSTING THE REAR BRAKE LIGHT SWITCH” in chapter 3.

EAS00613

FRONT BRAKE CALIPERS

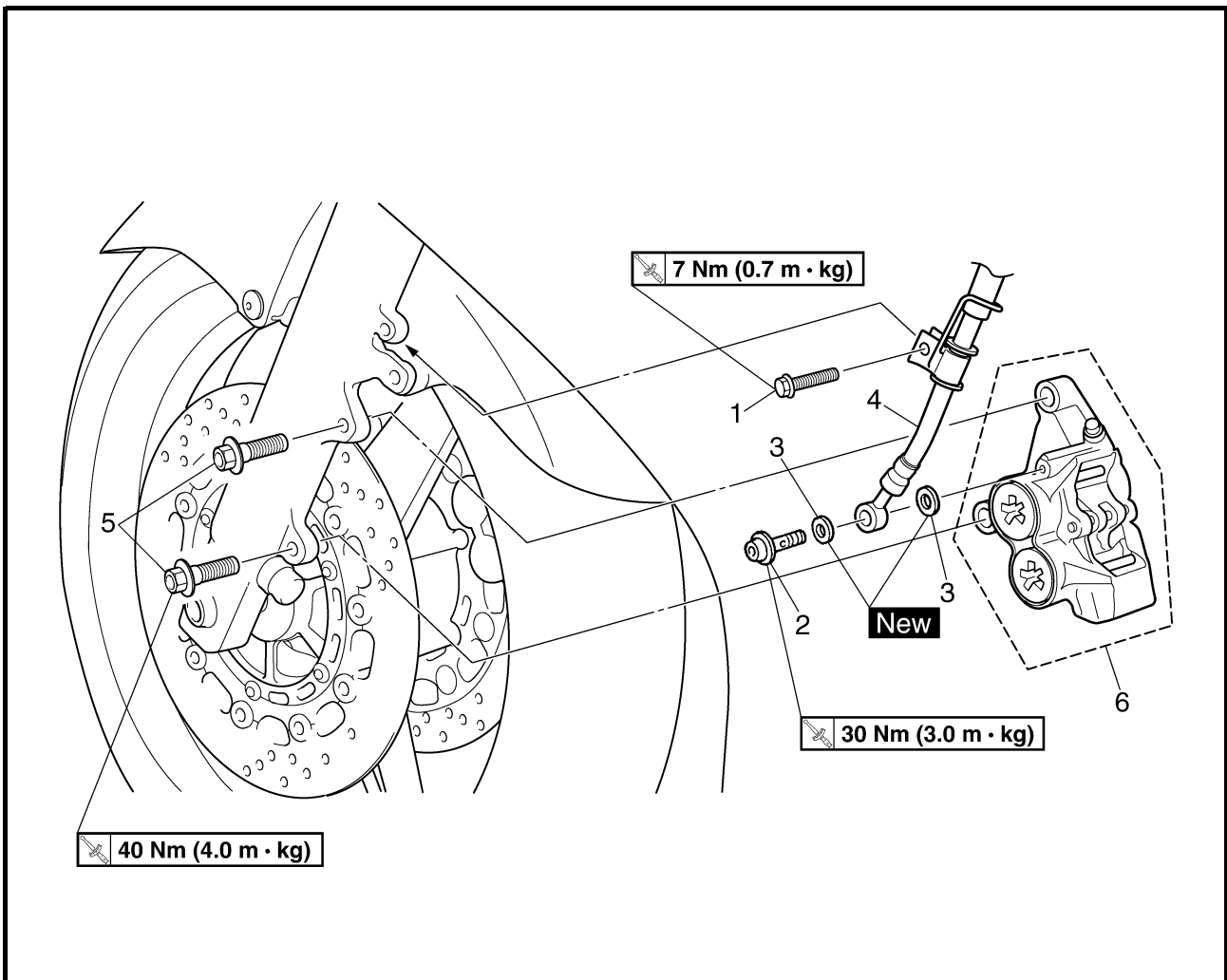

Order	Job/Part	Q'ty	Remarks
	Removing the front brake calipers		Remove the parts in the order listed. The following procedure applies to both of the front brake calipers. Drain.
	Brake fluid		
1	Brake hose holder bolt	1	Disconnect. Refer to "DISASSEMBLING/ ASSEMBLING AND INSTALLING THE FRONT BRAKE CALIPERS".
2	Union bolt	1	
3	Copper washer	2	
4	Brake hose	1	
5	Brake caliper bolt	2	
6	Brake caliper	1	
			For installation, reverse the removal procedure.

EAS00615

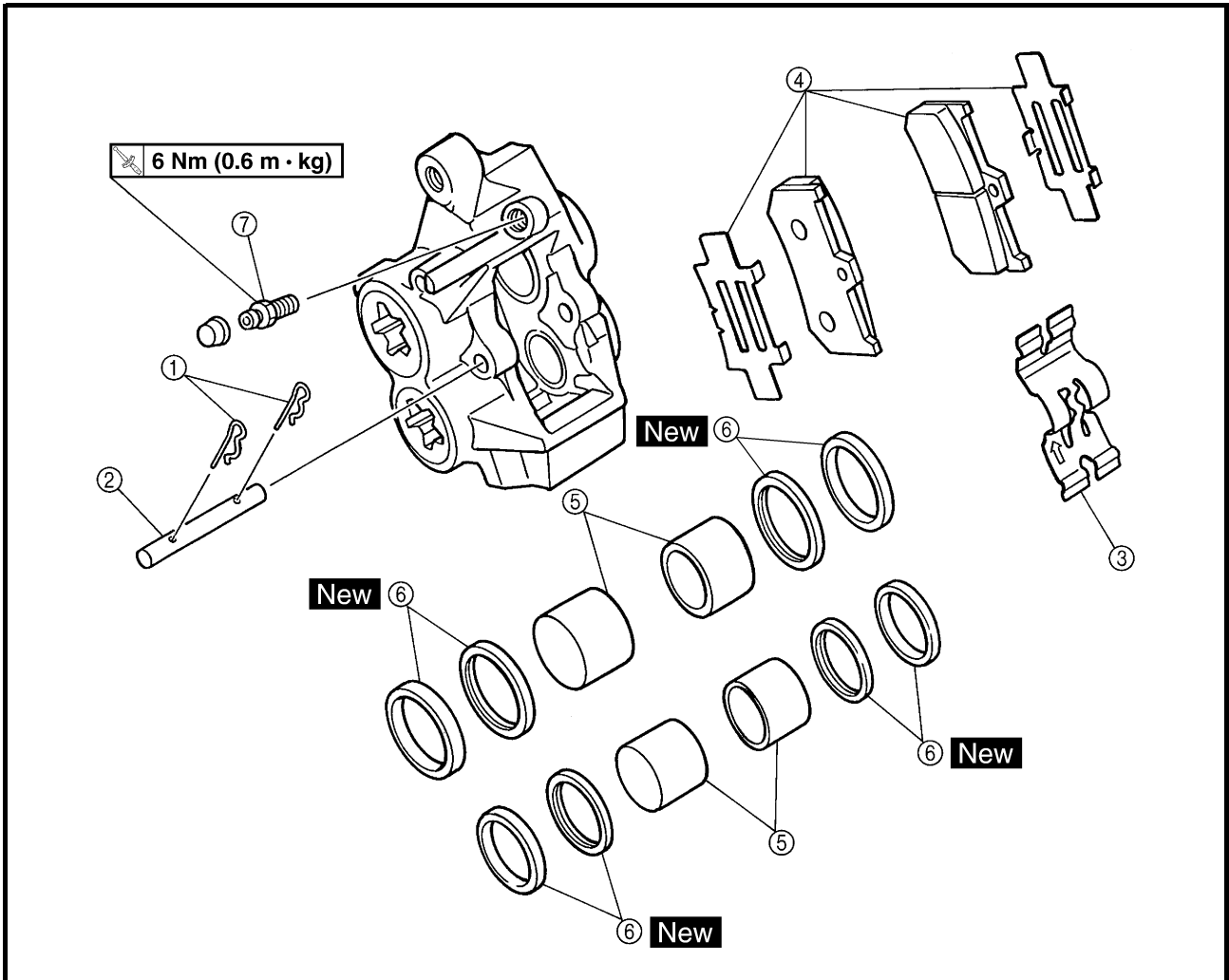

Order	Job/Part	Q'ty	Remarks
	Disassembling the front brake calipers		Remove the parts in the order listed.
			The following procedure applies to both of the front brake calipers.
①	Brake pad clip	2	Refer to "DISASSEMBLING THE FRONT BRAKE CALIPERS". For assembly, reverse the disassembly procedure.
②	Brake pad pin	1	
③	Brake pad spring	1	
④	Brake pad/brake pad shim	2/2	
⑤	Brake caliper piston	4	
⑥	Brake caliper piston seal	8	
⑦	Bleed screw	1	

EAS00616

REAR BRAKE CALIPER

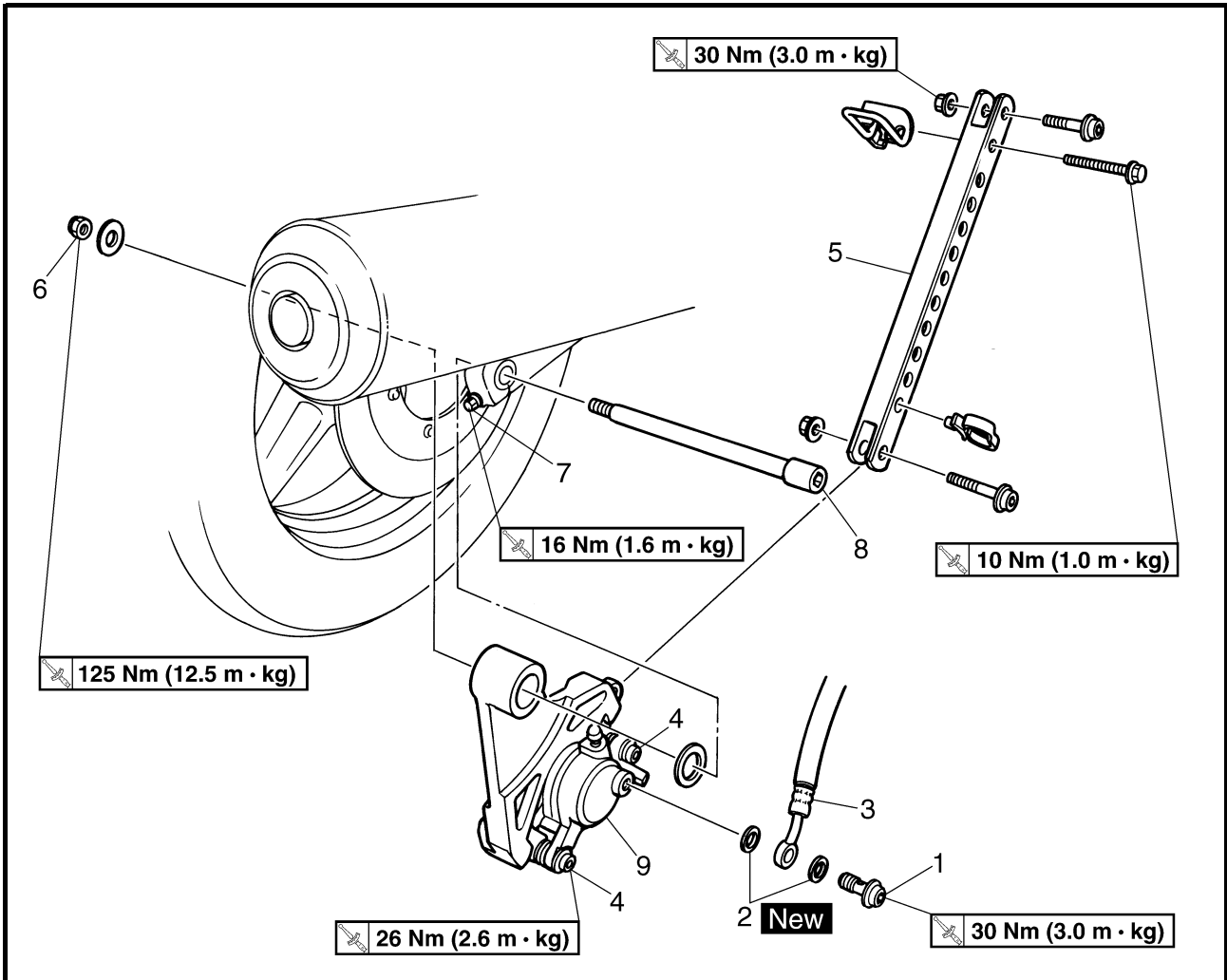

Order	Job/Part	Q'ty	Remarks
	Removing the rear brake caliper		Remove the parts in the order listed.
	Brake fluid		Drain.
1	Union bolt	1	Disconnect. Refer to "DISASSEMBLING/ ASSEMBLING AND INSTALLING THE REAR BRAKE CALIPER". For installation, reverse the removal procedure.
2	Copper washer	2	
3	Brake hose	1	
4	Retaining bolt	2	
5	Brake torque rod	1	
6	Wheel axle nut	1	
7	Wheel axle pinch bolt	1	
8	Rear wheel axle	1	
9	Brake caliper	1	

EAS00617

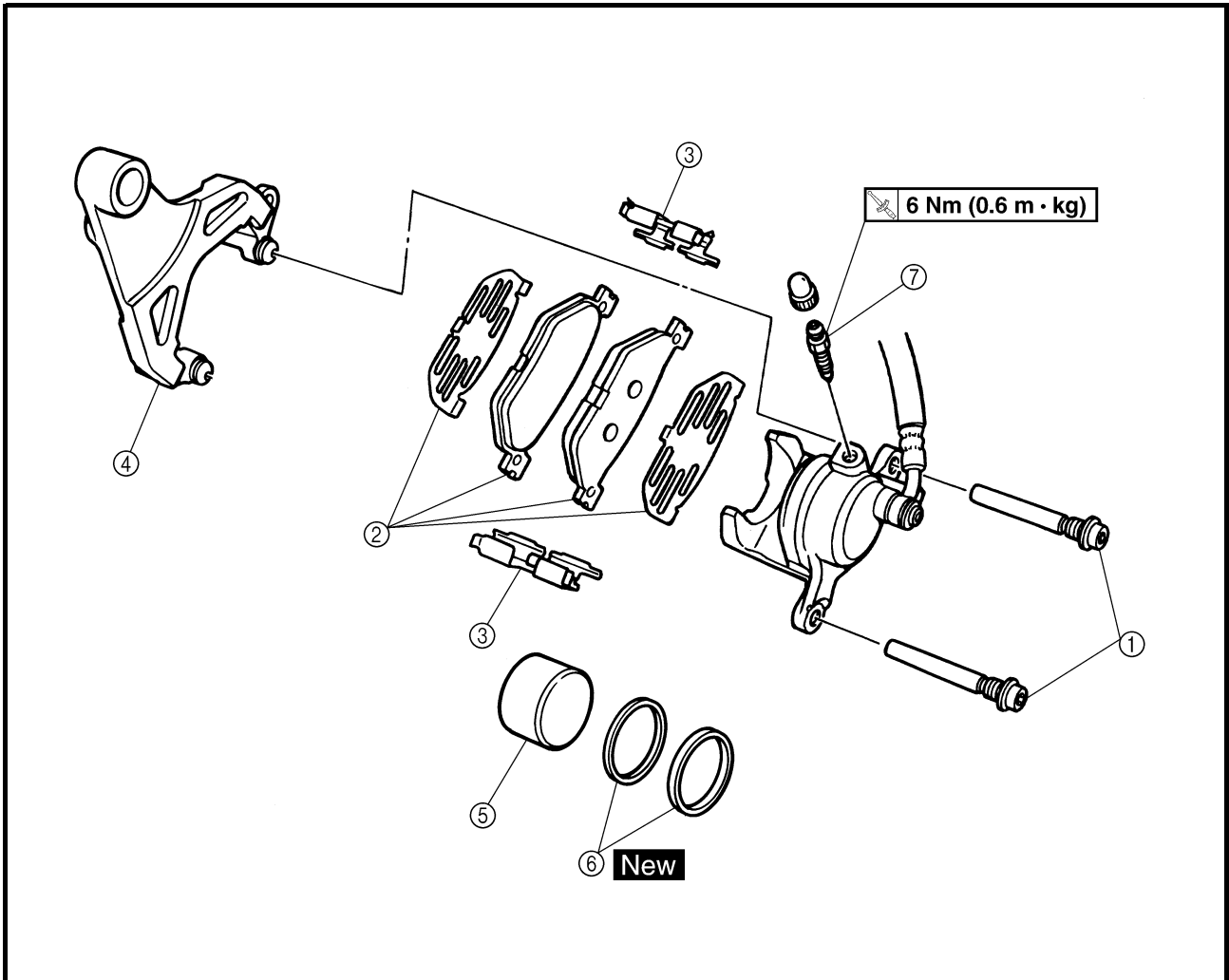

Order	Job/Part	Q'ty	Remarks
	Disassembling the rear brake caliper		Remove the parts in the order listed.
①	Retaining bolt	2	Refer to "DISASSEMBLING THE REAR BRAKE CALIPER". For assembly, reverse the disassembly procedure.
②	Brake pad/brake pad shim	2/2	
③	Brake pad spring	2	
④	Rear brake caliper bracket	1	
⑤	Brake caliper piston	1	
⑥	Brake caliper piston seal	2	
⑦	Bleed screw	1	

EAS00625

DISASSEMBLING THE FRONT BRAKE CALIPERS

The following procedure applies to both of the brake calipers.

NOTE:

Before disassembling either brake caliper, drain the brake fluid from the entire brake system.

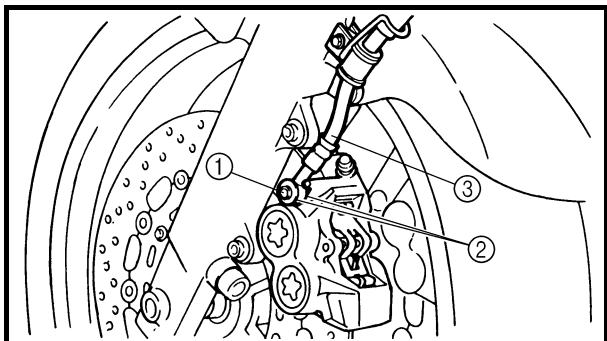
**1. Remove:**

- union bolt ①
- copper washers ②
- brake hose ③

NOTE:

Put the end of the brake hose into a container and pump out the brake fluid carefully.

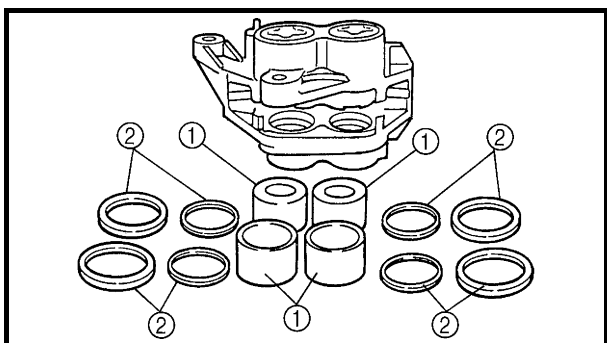
**2. Remove:**

- brake caliper pistons ①
- brake caliper piston seals ②



- a. Secure the right side brake caliper pistons with a piece of wood (a).
- b. Blow compressed air into the brake hose joint opening (b) to force out the left side pistons from the brake caliper.

⚠ WARNING

- Never try to pry out the brake caliper pistons.
- Do not loosen the bolts ③.

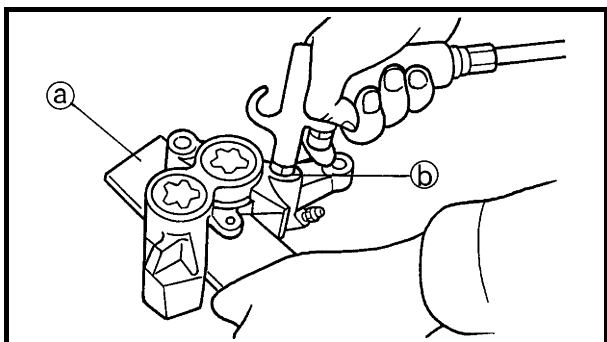

- c. Remove the brake caliper piston seals.
- d. Repeat the previous steps to force out the right side pistons from the brake caliper.

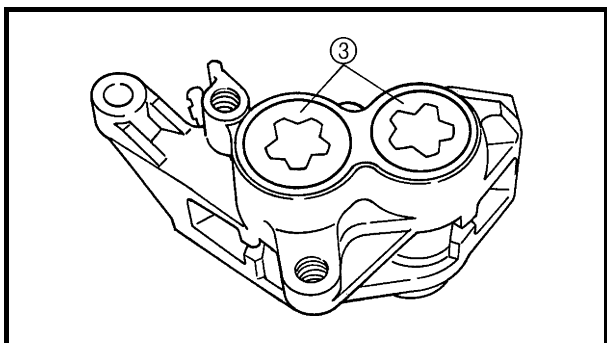

EAS00633

CHECKING THE FRONT AND REAR BRAKE CALIPERS

Recommended brake component replacement schedule	
Brake pads	If necessary
Piston seals	Every two years
Brake hoses	Every two years
Brake fluid	Every two years and whenever the brake is disassembled

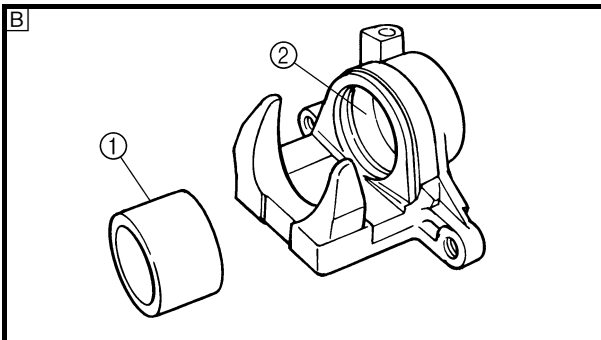
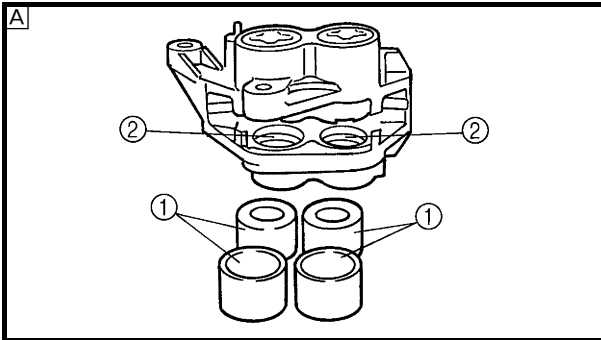

1. Check:

- brake caliper pistons ①
Rust/scratches/wear → Replace the brake caliper.
- brake caliper cylinders ②
Scratches/wear → Replace the brake caliper.
- brake calipers
Cracks/damage → Replace.
- brake fluid delivery passages (brake caliper body)
Obstruction → Blow out with compressed air.

⚠ WARNING

Whenever a brake caliper is disassembled, replace the brake caliper piston seals.

- Ⓐ Front
- Ⓑ Rear

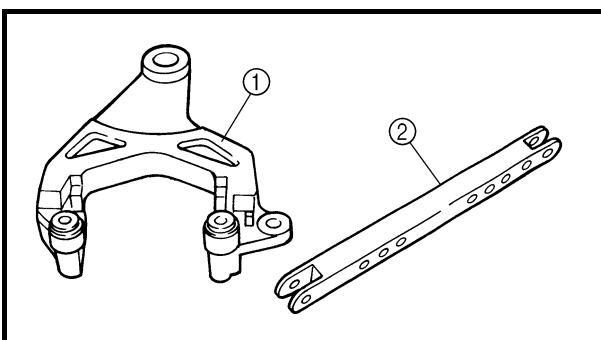

2. Check:

- rear brake caliper bracket ①
- brake torque rod ②
Cracks/damage → Replace.

EAS00638

ASSEMBLING AND INSTALLING THE FRONT BRAKE CALIPERS

The following procedure applies to both of the brake calipers.

⚠ WARNING

- Before installation, all internal brake components should be cleaned and lubricated with clean or new brake fluid.
- Never use solvents on internal brake components as they will cause the piston seals to swell and distort.
- Whenever a brake caliper is disassembled, replace the brake caliper piston seals.



Recommended brake fluid
DOT 4

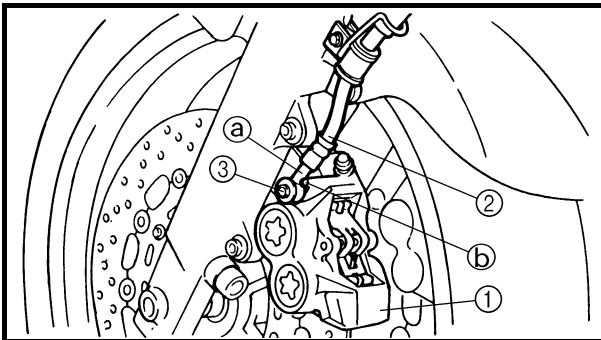

1. Install:

- brake caliper ① (temporarily)
- copper washers **New**
- brake hose ②
- union bolt ③

30 Nm (3.0 m · kg)

⚠ WARNING

Proper brake hose routing is essential to insure safe motorcycle operation. Refer to "CABLE ROUTING".

CAUTION:



When installing the brake hose onto the brake caliper ①, make sure the brake pipe ① touches the projection ② on the brake caliper.

2. Remove:

- brake caliper

3. Install:

- brake pads
- brake pad spring
- brake caliper
- brake hose holder

	40 Nm (4.0 m · kg)
	7 Nm (0.7 m · kg)

Refer to “REPLACING THE FRONT BRAKE PADS”.

4. Fill:

- brake master cylinder reservoir
(with the specified amount of the recommended brake fluid)

	Recommended brake fluid DOT 4
---	--

⚠ WARNING

- Use only the designated brake fluid. Other brake fluids may cause the rubber seals to deteriorate, causing leakage and poor brake performance.
- Refill with the same type of brake fluid that is already in the system. Mixing brake fluids may result in a harmful chemical reaction, leading to poor brake performance.
- When refilling, be careful that water does not enter the brake master cylinder reservoir. Water will significantly lower the boiling point of the brake fluid and could cause vapor lock.

CAUTION:

Brake fluid may damage painted surfaces and plastic parts. Therefore, always clean up any spilt brake fluid immediately.

5. Bleed:

- brake system

Refer to “BLEEDING THE HYDRAULIC BRAKE SYSTEM” in chapter 3.

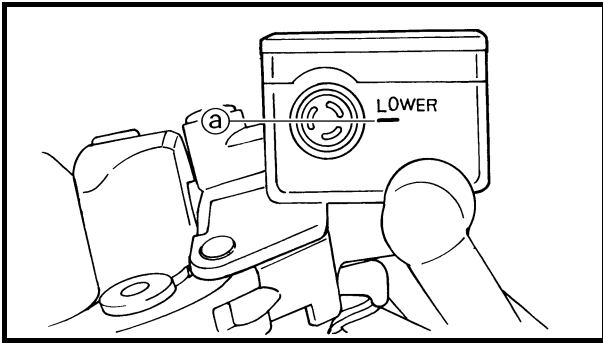

6. Check:
 - brake fluid level
Below the minimum level mark (a) → Add the recommended brake fluid to the proper level.
Refer to “CHECKING THE BRAKE FLUID LEVEL” in chapter 3.

7. Check:
 - brake lever operation
Soft or spongy feeling → Bleed the brake system.
Refer to “BLEEDING THE HYDRAULIC BRAKE SYSTEM” in chapter 3.

EAS00642

ASSEMBLING AND INSTALLING THE REAR BRAKE CALIPER

WARNING

- Before installation, all internal brake components should be cleaned and lubricated with clean or new brake fluid.
- Never use solvents on internal brake components as they will cause the piston seals to swell and distort.
- Whenever a brake caliper is disassembled, replace the brake caliper piston seals.

	Recommended brake fluid DOT 4
---	--

1. Lubricate:
 - wheel axle

	Recommended lubricant Lithium soap base grease
---	---

2. Tighten:

- brake torque rod

	30 Nm (3.0 m · kg)
---	---------------------------
- wheel axle nut

	125 Nm (12.5 m · kg)
---	-----------------------------
- wheel axle pinch bolt

	16 Nm (1.6 m · kg)
---	---------------------------

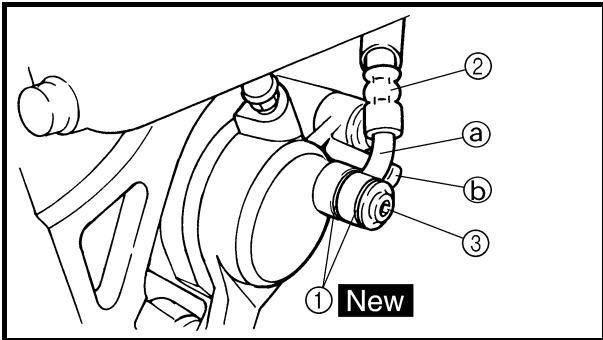

3. Install:

- brake caliper (temporarily)
- copper washers ①

New

- brake hose ②
- union bolt ③

	30 Nm (3.0 m · kg)
---	---------------------------

⚠ WARNING

Proper brake hose routing is essential to insure safe motorcycle operation. Refer to “CABLE ROUTING”.

CAUTION:

When installing the brake hose onto the brake caliper, make sure the brake pipe ① touches the projection ② on the brake caliper.

4. Remove:

- brake caliper

5. Install:

- brake pad springs
- brake pads
- brake caliper
- retaining bolts

	26 Nm (2.6 m · kg)
---	---------------------------

Refer to “REPLACING THE REAR BRAKE PADS”.

6. Fill:
- brake fluid reservoir
(with the specified amount of the recommended brake fluid)

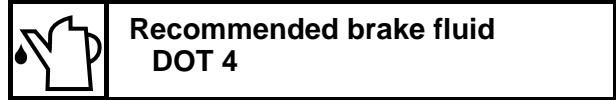
**⚠ WARNING**

- Use only the designated brake fluid. Other brake fluids may cause the rubber seals to deteriorate, causing leakage and poor brake performance.
- Refill with the same type of brake fluid that is already in the system. Mixing brake fluids may result in a harmful chemical reaction, leading to poor brake performance.
- When refilling, be careful that water does not enter the brake fluid reservoir. Water will significantly lower the boiling point of the brake fluid and could cause vapor lock.

CAUTION:

Brake fluid may damage painted surfaces and plastic parts. Therefore, always clean up any spilt brake fluid immediately.

7. Bleed:
- brake system
Refer to “BLEEDING THE HYDRAULIC BRAKE SYSTEM” in chapter 3.

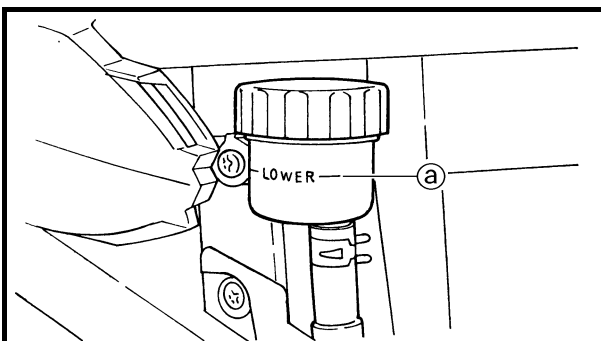

8. Check:
- brake fluid level
Below the minimum level mark (a) → Add the recommended brake fluid to the proper level.
Refer to “CHECKING THE BRAKE FLUID LEVEL” in chapter 3.



9. Check:
 - brake pedal operation
Soft or spongy feeling → Bleed the brake system.
Refer to “BLEEDING THE HYDRAULIC BRAKE SYSTEM” in chapter 3.

EAS00305

**HYDRAULIC CLUTCH
CLUTCH MASTER CYLINDER**

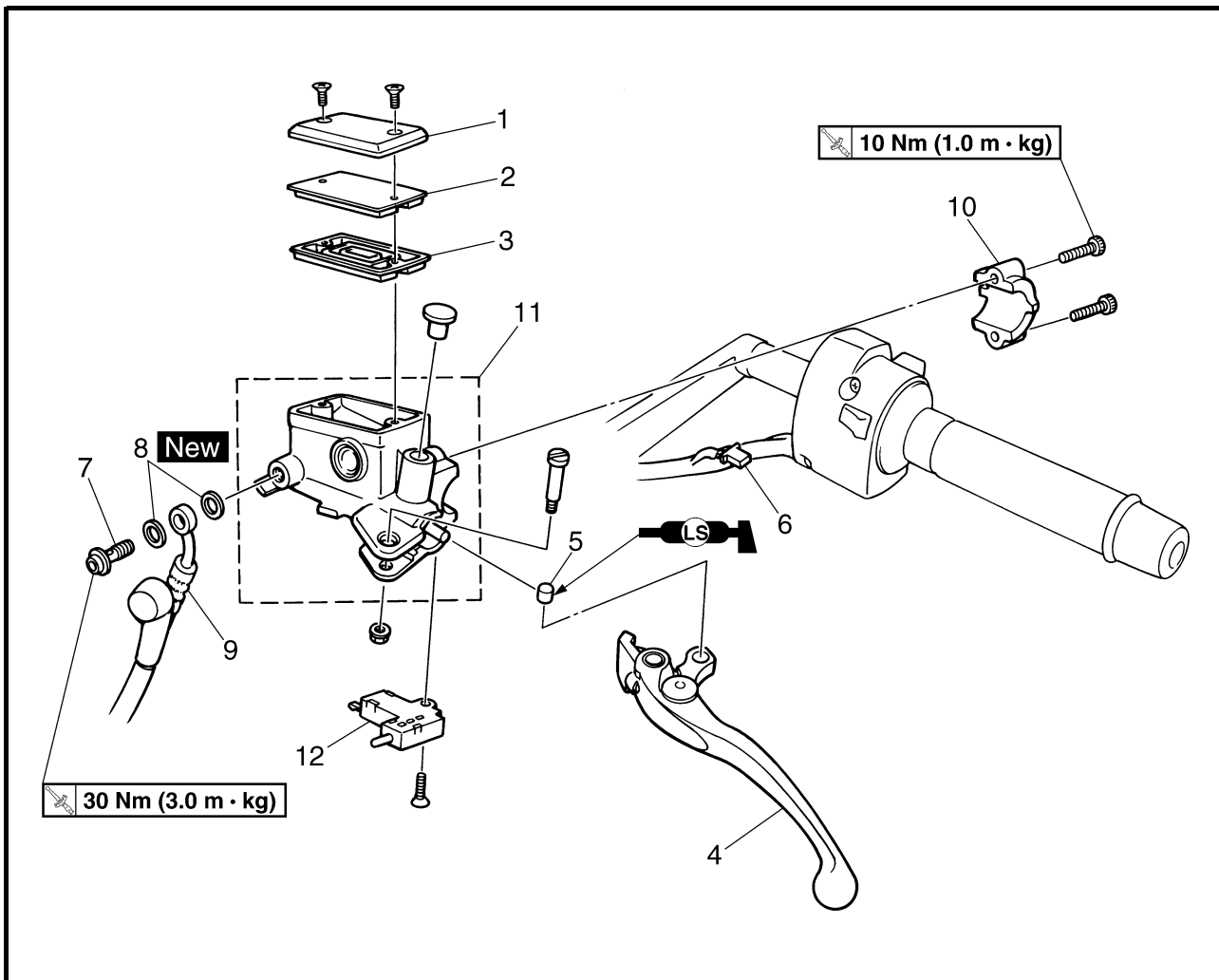

Order	Job/Part	Q'ty	Remarks
	Removing the clutch master cylinder		Remove the parts in the order listed.
	Clutch fluid		Drain.
1	Clutch master reservoir cap	1	
2	Clutch master reservoir diaphragm holder	1	
3	Clutch master reservoir diaphragm	1	
4	Clutch lever	1	
5	Bushing	1	
6	Clutch switch coupler	1	Disconnect.

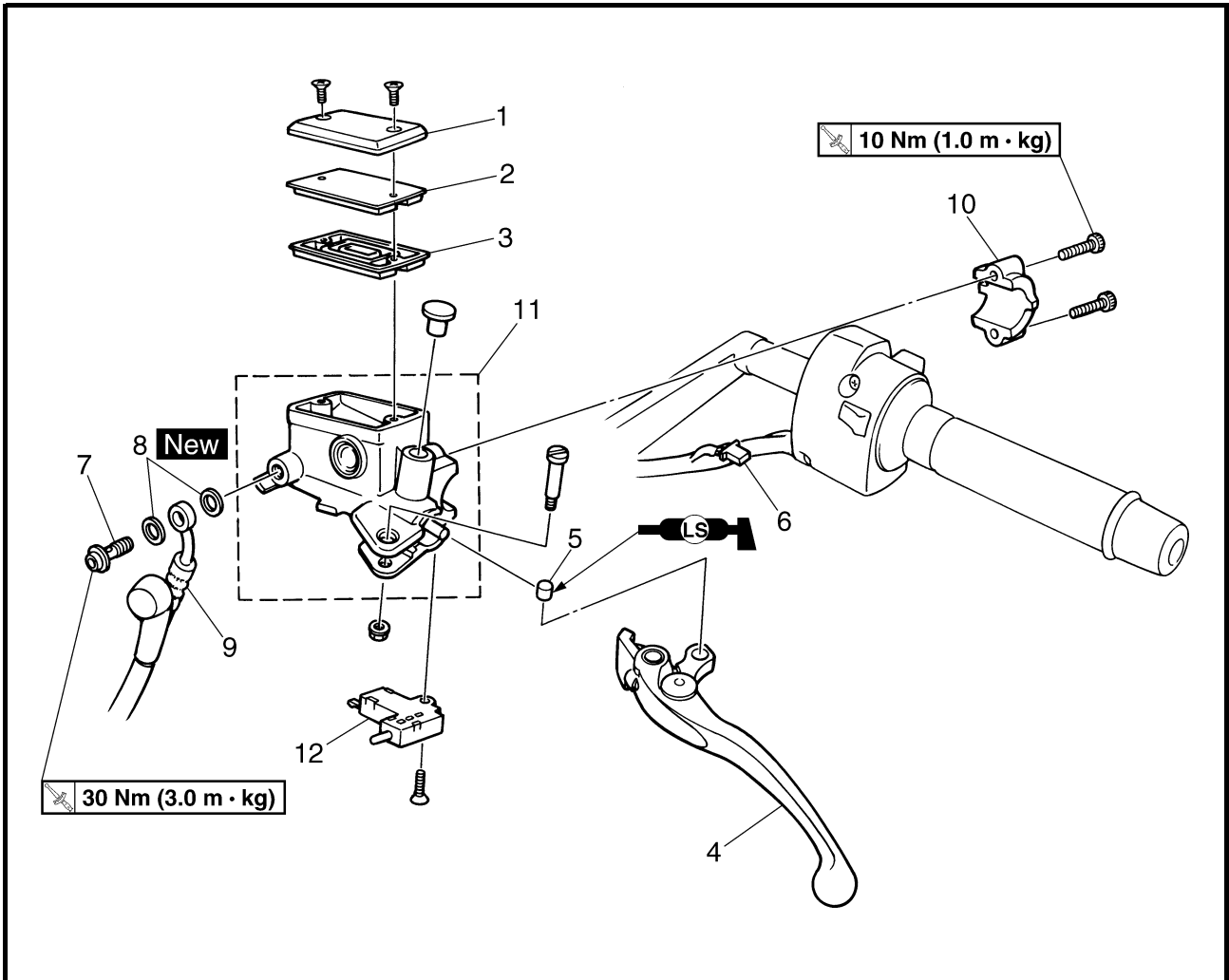

Order	Job/Part	Q'ty	Remarks
7	Union bolt	1	Disconnect. } Refer to "DISASSEMBLING/ ASSEMBLING AND INSTALLING THE CLUTCH MASTER CYLINDER".
8	Copper washer	2	
9	Clutch hose	1	
10	Clutch master cylinder holder	1	
11	Clutch master cylinder	1	Refer to "ASSEMBLING AND INSTALLING THE CLUTCH MASTER CYLINDER".
12	Clutch switch	1	For installation, reverse the removal procedure.

EAS00306

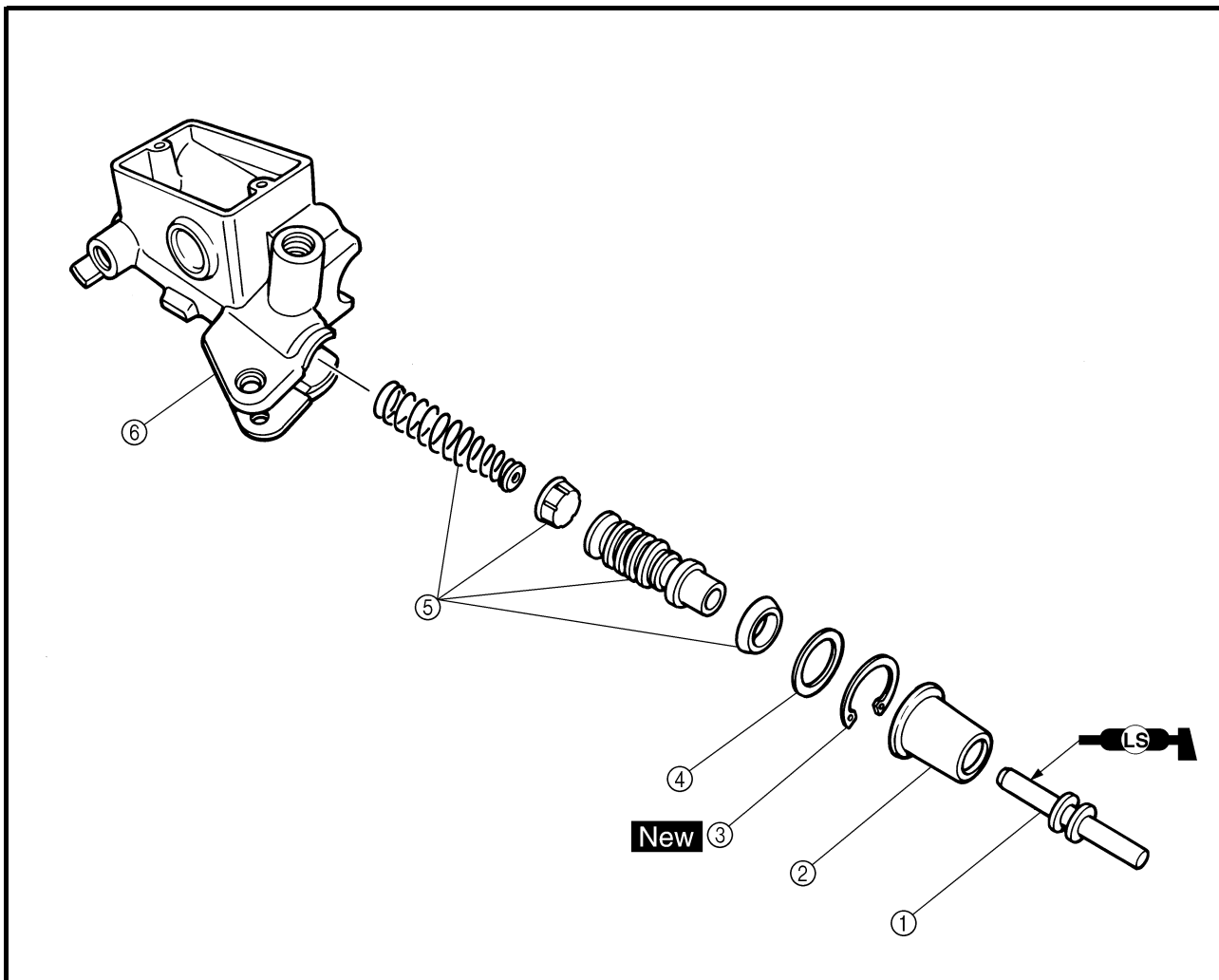

Order	Job/Part	Q'ty	Remarks
	Disassembling the clutch master cylinder		Remove the parts in the order listed.
①	Clutch master cylinder push rod	1	
②	Dust seal	1	
③	Circlip	1	
④	Washer	1	
⑤	Clutch master cylinder kit	1	
⑥	Clutch master cylinder	1	
			For assembly, reverse the disassembly procedure.

EAS00307

CAUTION:

Clutch components rarely require disassembly.

Therefore, always follow these preventive measures:

- Never disassemble clutch components unless absolutely necessary.
- If any connection on the hydraulic clutch system is disconnected, the entire clutch system must be disassembled, drained, cleaned, properly filled, and bled after reassembly.
- Never use solvents on internal clutch components.
- Use only clean or new clutch fluid for cleaning clutch components.
- Clutch fluid may damage painted surfaces and plastic parts. Therefore, always clean up any spilt fluid immediately.
- Avoid clutch fluid coming into contact with the eyes as it can cause serious injury.
- First aid for clutch fluid entering the eyes:
- Flush with water for 15 minutes and get immediate medical attention.

DISASSEMBLING THE CLUTCH MASTER CYLINDER**NOTE:**

Before disassembling the clutch master cylinder, drain the clutch fluid from the entire clutch system.

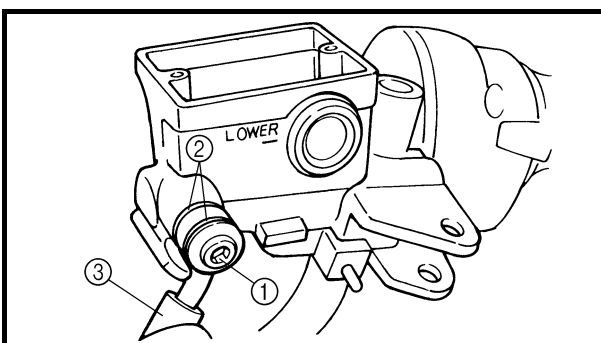

1. Remove:

- union bolt ①
- copper washers ②
- clutch hose ③

NOTE:

To collect any remaining clutch fluid, place a container under the master cylinder and the end of the clutch hose.

EAS00308

CHECKING THE CLUTCH MASTER CYLINDER

Recommended clutch component replacement schedule	
Piston seals	Every two years
Clutch hose	Every two years
Clutch fluid	Every two years and whenever the clutch is disassembled

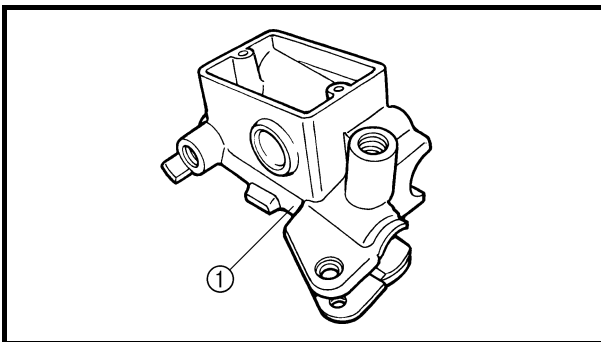

1. Check:

- clutch master cylinder body ①
Cracks/damage → Replace the clutch master cylinder.
- clutch fluid delivery passage (clutch master cylinder body)
Obstruction → Blow out with compressed air.

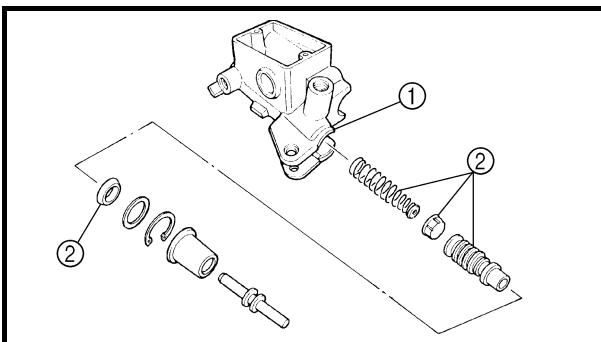

2. Check:

- clutch master cylinder ①
- clutch master cylinder kit ②
Rust/scratches/wear → Replace the clutch master cylinder and clutch master cylinder kit as a set.

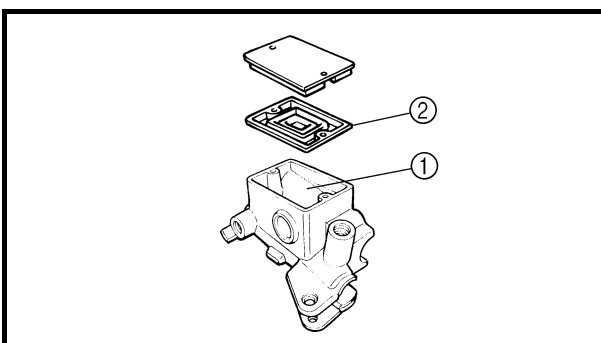

3. Check:

- clutch master cylinder reservoir ①
Cracks/damage → Replace.
- clutch master cylinder reservoir diaphragm ②
Damage/wear → Replace.

4. Check:

- clutch hose
Cracks/damage/wear → Replace.

EAS00309
EAS00310

ASSEMBLING AND INSTALLING THE CLUTCH MASTER CYLINDER

⚠ WARNING

- Before installation, all internal clutch components must be cleaned and lubricated with clean or new clutch fluid.
- Never use solvents on internal clutch components as they will cause the piston seals to swell and distort.



Recommended clutch fluid
Brake fluid DOT 4

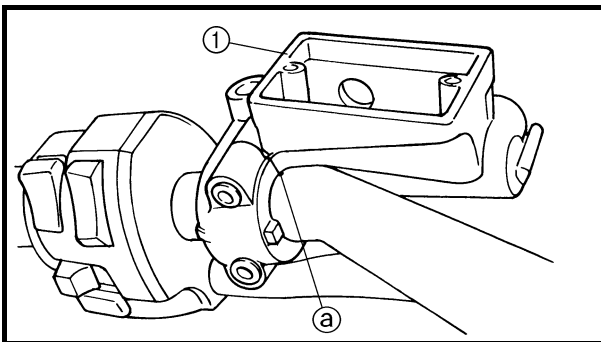

1. Install:

- clutch master cylinder ①

 10 Nm (1.0 m · kg)

NOTE:

- Install the clutch master cylinder holder with the “UP” mark facing up.
- Align the end of the clutch master cylinder holder with the punch mark ① in the left handlebar.
- First, tighten the upper bolt, then the lower bolt.

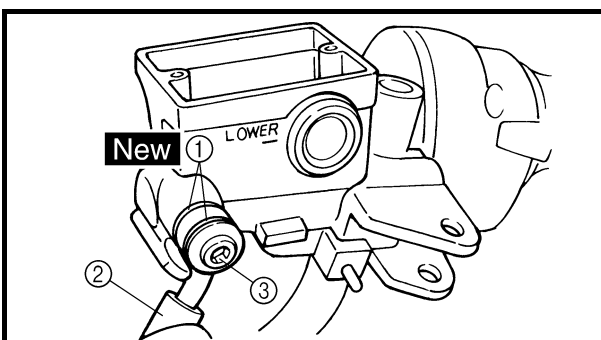

2. Install:

- copper washers ① **New**
- clutch hose ②
- union bolt ③

 30 Nm (3.0 m · kg)

⚠ WARNING

Proper clutch hose routing is essential to insure safe motorcycle operation. Refer to “CABLE ROUTING”.

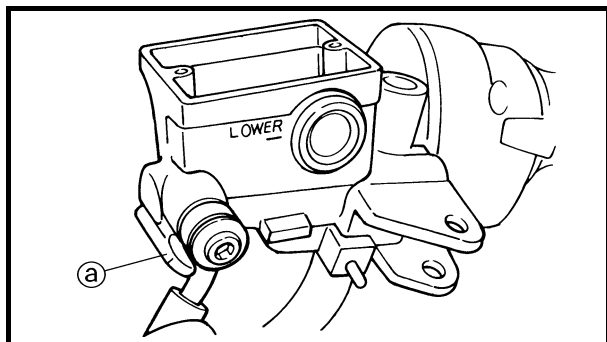
**CAUTION:**

When installing the clutch hose onto the clutch master cylinder, make sure the clutch pipe touches the projection ① as shown.

NOTE:

Turn the handlebars to the left and to the right to make sure the clutch hose does not touch other parts (e.g., wire harness, cables, leads). Correct if necessary.

3. Fill:

- clutch master cylinder reservoir (with the specified amount of the recommended clutch fluid)



Recommended clutch fluid
Brake fluid DOT 4

⚠ WARNING

- Use only the designated clutch fluid. Other clutch fluids may cause the rubber seals to deteriorate, causing leakage and poor clutch performance.
- Refill with the same type of clutch fluid that is already in the system. Mixing clutch fluids may result in a harmful chemical reaction, leading to poor clutch performance.
- When refilling, be careful that water does not enter the clutch fluid reservoir. Water will significantly lower the boiling point of the clutch fluid and could cause vapor lock.

CAUTION:

Clutch fluid may damage painted surfaces or plastic parts. Therefore, always clean up any spilled clutch fluid immediately.

4. Bleed:
 - clutch systemRefer to “BLEEDING THE HYDRAULIC CLUTCH SYSTEM” in chapter 3.

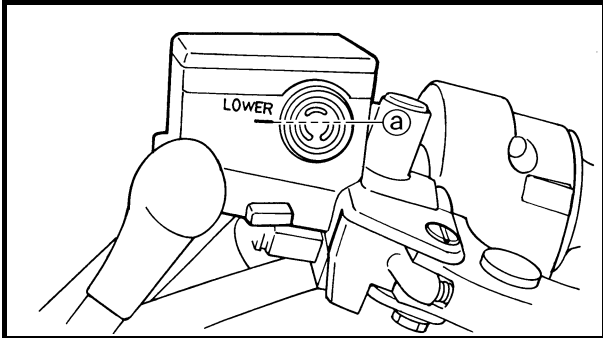

5. Check:
 - clutch fluid levelBelow the minimum level mark (a) → Add the recommended clutch fluid to the proper level.
Refer to “CHECKING THE CLUTCH FLUID LEVEL” in chapter 3.
6. Check:
 - clutch lever operationSoft or spongy feeling → Bleed the clutch system.
Refer to “BLEEDING THE HYDRAULIC CLUTCH SYSTEM” in chapter 3.

EAS00311

CLUTCH RELEASE CYLINDER

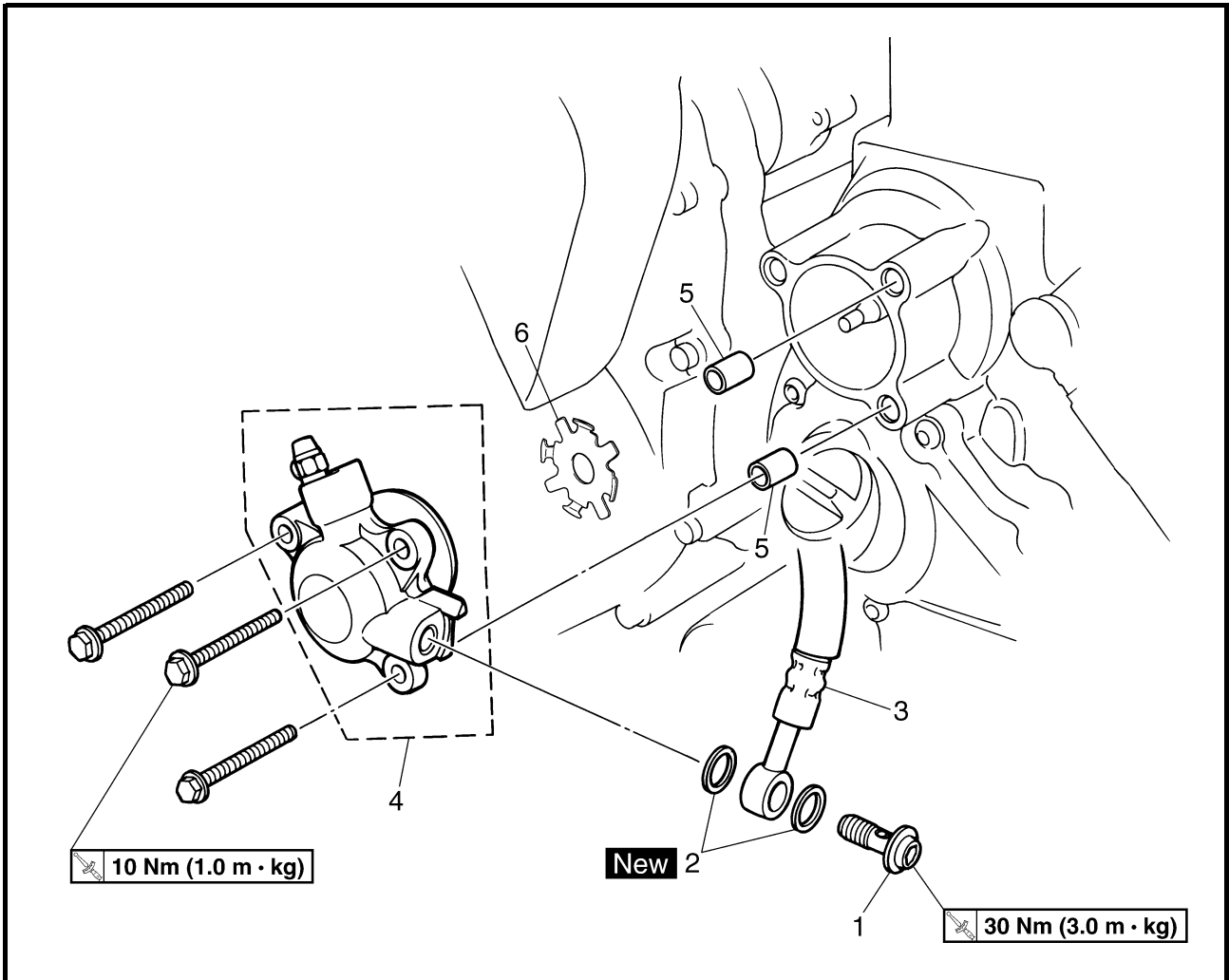

Order	Job/Part	Q'ty	Remarks
	Removing the clutch release cylinder		Remove the parts in the order listed.
	Clutch fluid		Drain.
1	Union bolt	1	Disconnect. } Refer to "DISASSEMBLING/ ASSEMBLING AND INSTALLING THE CLUTCH MASTER CYLINDER".
2	Copper washer	2	
3	Clutch hose	1	
4	Clutch release cylinder	1	
5	Dowel pin	2	
6	Plate	1	
			For installation, reverse the removal procedure.

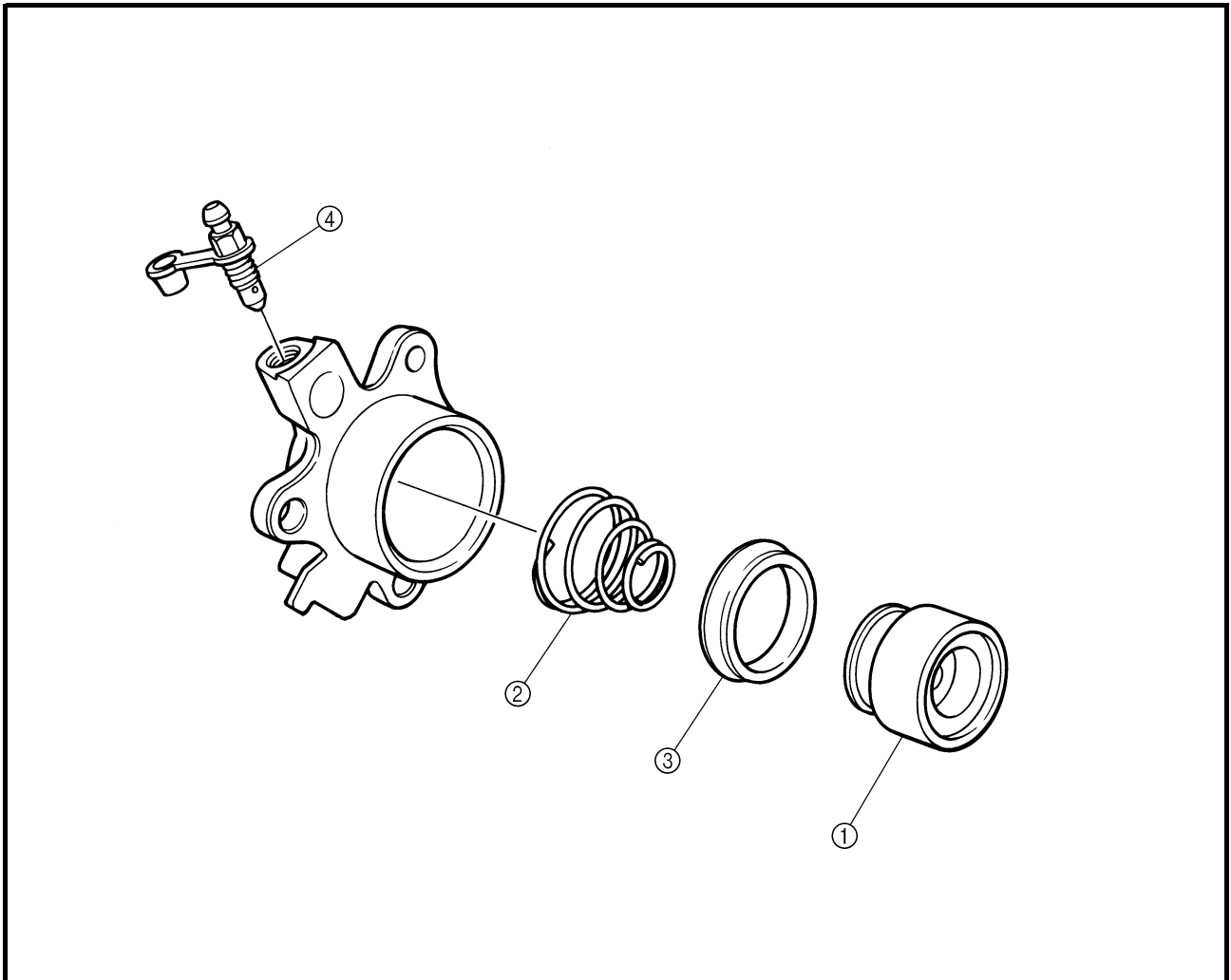

Order	Job/Part	Q'ty	Remarks
	Disassembling the clutch release cylinder		Remove the parts in the order listed.
①	Clutch release cylinder piston	1	Refer to "DISASSEMBLING THE CLUTCH RELEASE CYLINDER".
②	Clutch release cylinder spring	1	
③	Clutch release cylinder piston seal	1	
④	Bleed screw	1	For assembly, reverse the disassembly procedure.

EAS00314

CHECKING THE CLUTCH RELEASE CYLINDER

Recommended clutch component replacement schedule	
Piston seal	Every two years
Clutch hose	Every two years
Clutch fluid	Every two years and whenever the clutch is disassembled

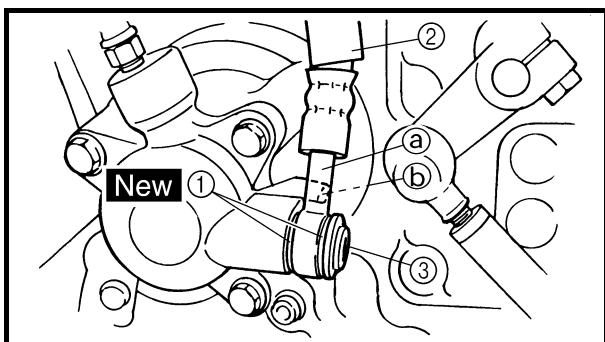
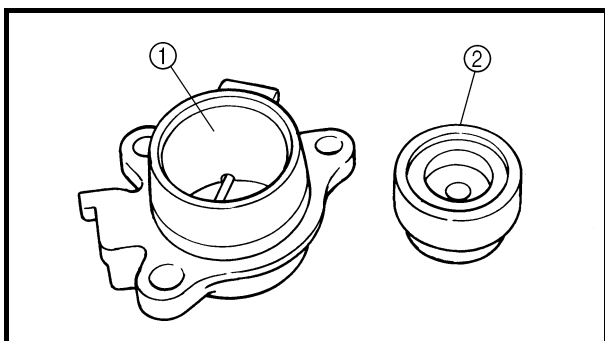
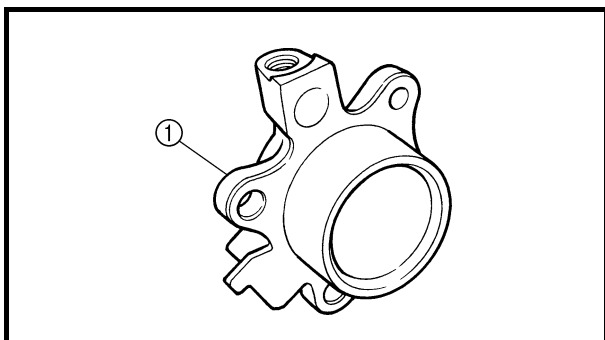

1. Check:

- clutch release cylinder body ①
Cracks/damage → Replace the clutch release cylinder.

2. Check:

- clutch release cylinder ①
- clutch release cylinder piston ②
Rust/scratches/wear → Replace the clutch release cylinder and clutch release cylinder piston as a set.

EAS00315

ASSEMBLING AND INSTALLING THE CLUTCH RELEASE CYLINDER

1. Install:

- copper washers ① **New**
- clutch hose ②
- union bolt ③

 **30 Nm (3.0 m · kg)**

⚠ WARNING

Proper clutch hose routing is essential to insure safe motorcycle operation. Refer to "CABLE ROUTING".

CAUTION:

When installing the clutch hose onto the clutch release cylinder, make sure the clutch pipe ① touches the projection ② on the clutch release cylinder.



2. Fill:

- clutch master cylinder reservoir
(with the specified amount of the recommended clutch fluid)



**Recommended clutch fluid
Brake fluid DOT 4**

⚠ WARNING

- Use only the designated clutch fluid. Other clutch fluids may cause the rubber seals to deteriorate, causing leakage and poor clutch performance.
- Refill with the same type of clutch fluid that is already in the system. Mixing clutch fluids may result in a harmful chemical reaction, leading to poor clutch performance.
- When refilling, be careful that water does not enter the clutch fluid reservoir. Water will significantly lower the boiling point of the clutch fluid and could cause vapor lock.

CAUTION:

Clutch fluid may damage painted surfaces or plastic parts. Therefore, always clean up any spilt clutch fluid immediately.

3. Bleed:

- clutch system
Refer to “BLEEDING THE HYDRAULIC CLUTCH SYSTEM” in chapter 3.

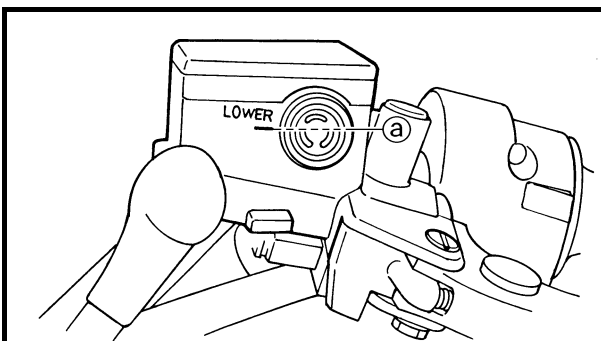

4. Check:

- clutch fluid level
Below the minimum level mark (a) → Add the recommended clutch fluid to the proper level.
Refer to “CHECKING THE CLUTCH FLUID LEVEL” in chapter 3.



5. Check:
- clutch lever operation
Soft or spongy feeling → Bleed the clutch system.
Refer to “BLEEDING THE HYDRAULIC CLUTCH SYSTEM” in chapter 3.

EAS00647

FRONT FORK

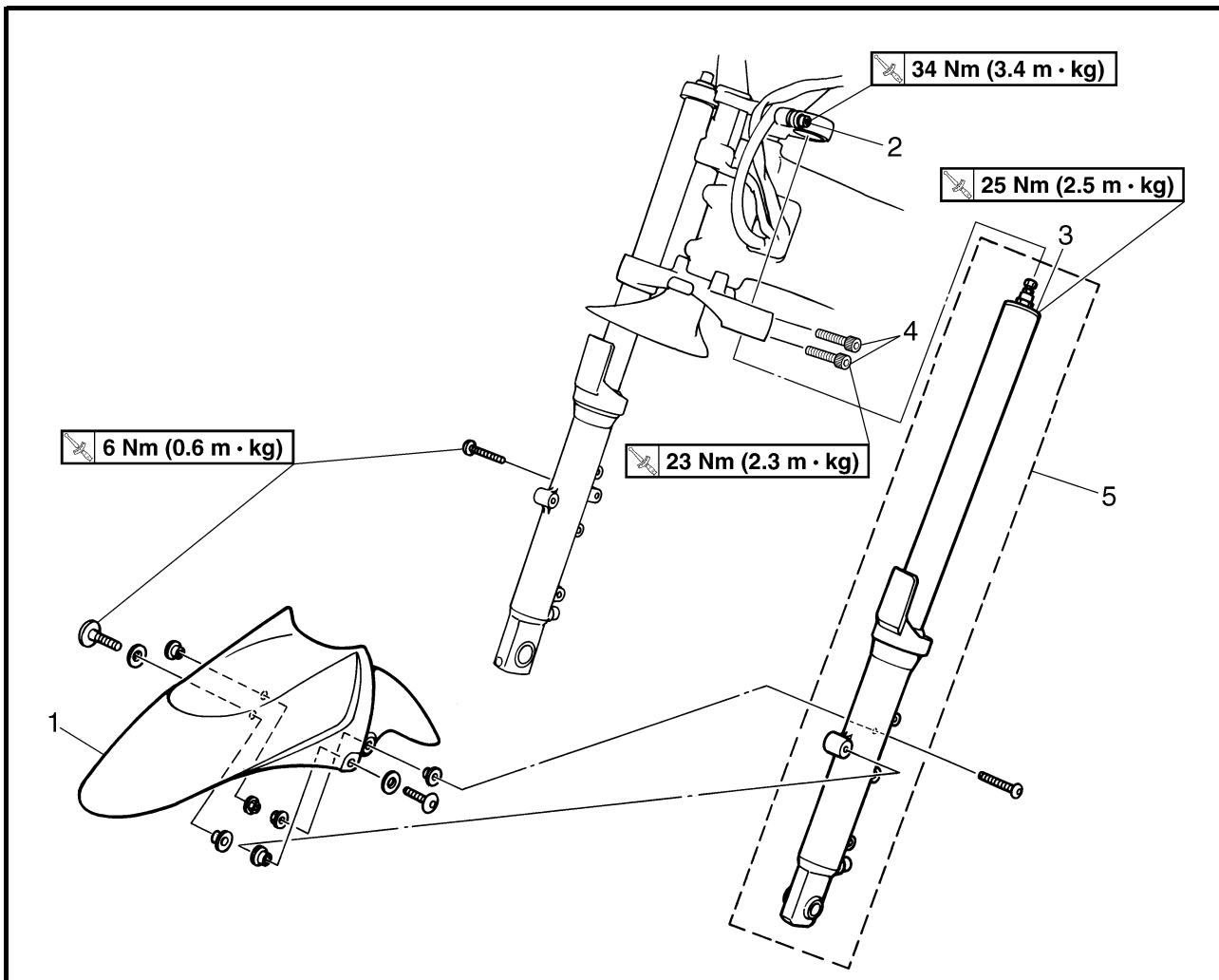

Order	Job/Part	Q'ty	Remarks	
	Removing the front fork legs		Remove the parts in the order listed. The following procedure applies to both of the front fork legs.	
	Front cowling assembly		Refer to "COWLINGS" AND "COVERS" in chapter 3.	
	Front wheel		Refer to "FRONT WHEEL AND BRAKE DISCS".	
1	Front fender	1	} Refer to "REMOVING/ INSTALLING THE FRONT FORK LEGS".	
2	Upper bracket pinch bolt	1		Loosen.
3	Cap bolt	1		Loosen.
4	Lower bracket pinch bolt	2		Loosen.
5	Front fork leg	1		
			For installation, reverse the removal procedure.	

EAS00648

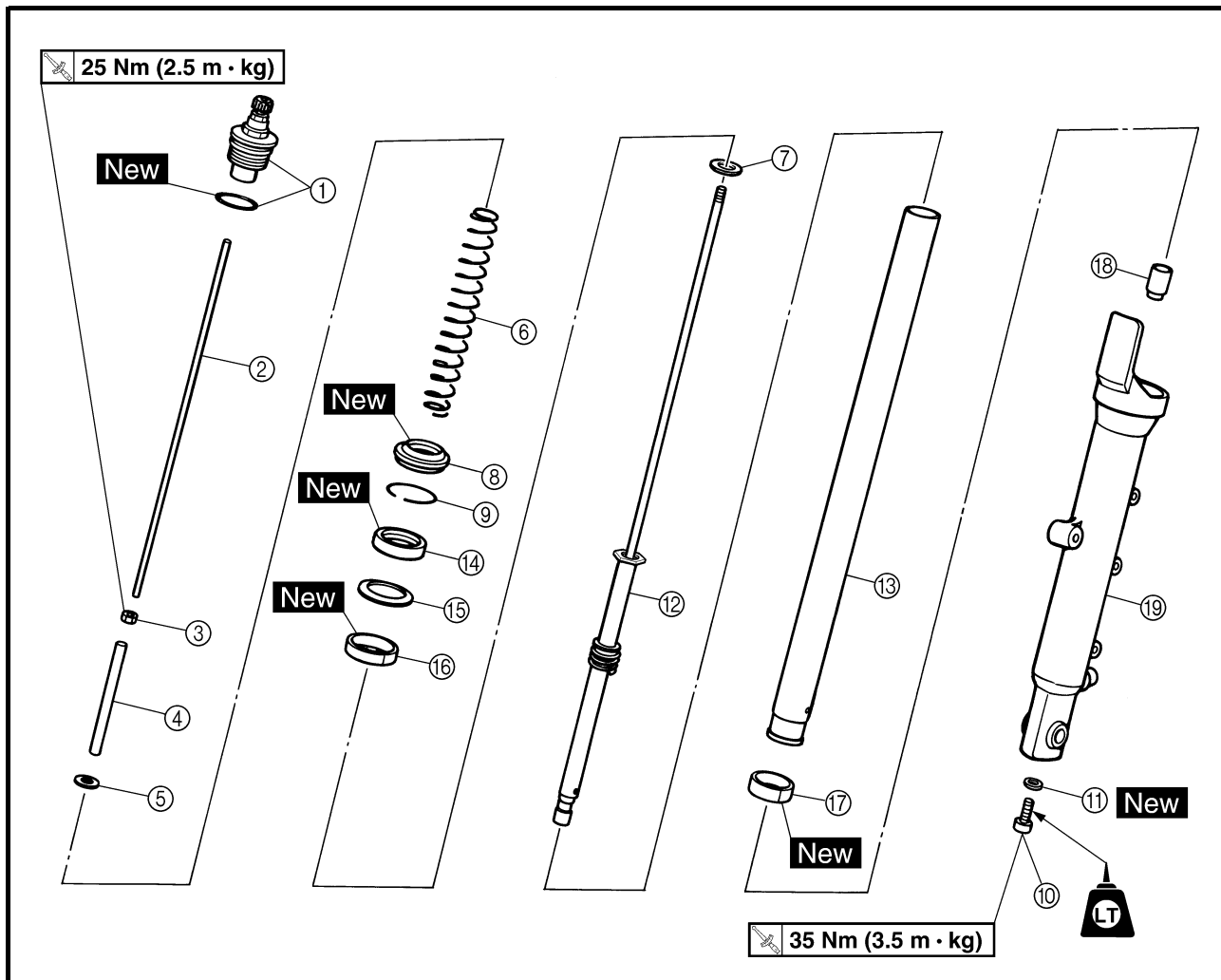

Order	Job/Part	Q'ty	Remarks
	Disassembling the front fork legs		Remove the parts in the order listed. The following procedure applies to both of the front fork legs.
①	Cap bolt/O-ring	1/1	Refer to "DISASSEMBLING/ ASSEMBLING THE FRONT FORK LEGS".
②	Damper adjusting rod	1	
③	Nut	1	
④	Spacer	1	
⑤	Washer	1	
⑥	Fork spring	1	
⑦	Spring seat	1	
⑧	Dust seal	1	
⑨	Oil seal clip	1	
⑩	Damper rod assembly bolt	1	
⑪	Copper washer	1	

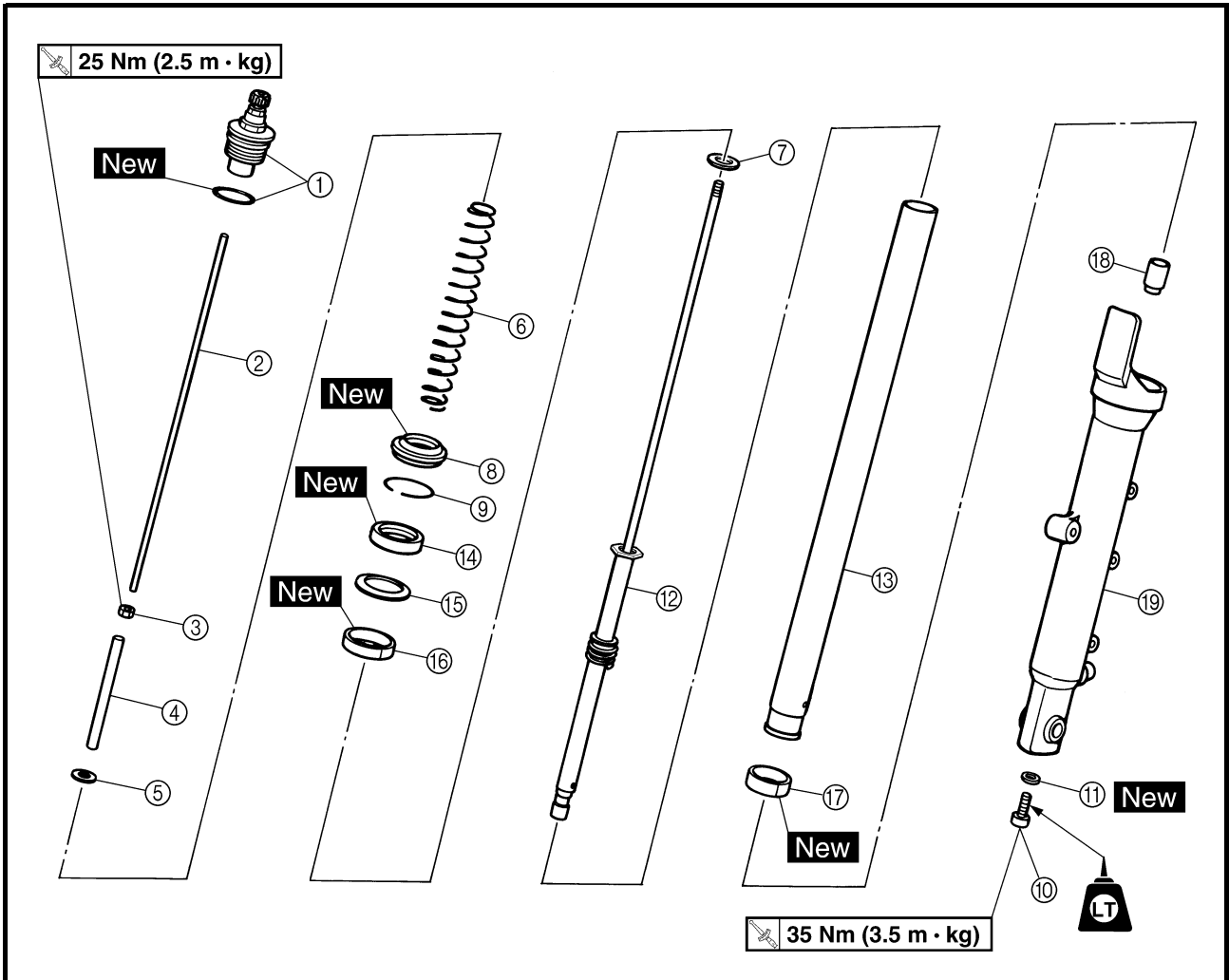

Order	Job/Part	Q'ty	Remarks
⑫	Damper rod assembly	1	Refer to "DISASSEMBLING/ ASSEMBLING THE FRONT FORK LEGS".
⑬	Inner tube	1	
⑭	Oil seal	1	Refer to "ASSEMBLING THE FRONT FORK LEGS".
⑮	Seal spacer	1	
⑯	Outer tube bushing	1	
⑰	Inner tube bushing	1	
⑱	Oil flow stopper	1	
⑲	Outer tube	1	
			For assembly, reverse the disassembly procedure.



EAS00649

REMOVING THE FRONT FORK LEGS

The following procedure applies to both of the front fork legs.

1. Stand the motorcycle on a level surface.

⚠ WARNING

Securely support the motorcycle so that there is no danger of it falling over.

NOTE:

Place the motorcycle on a suitable stand so that the front wheel is elevated.

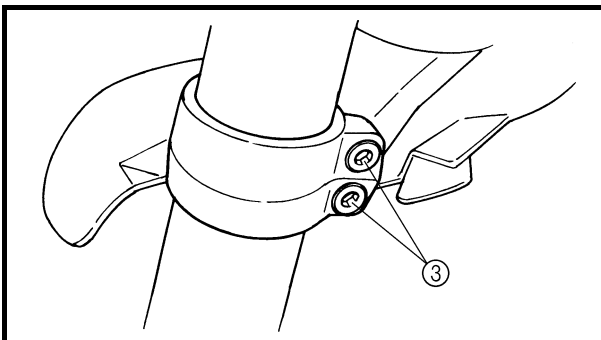
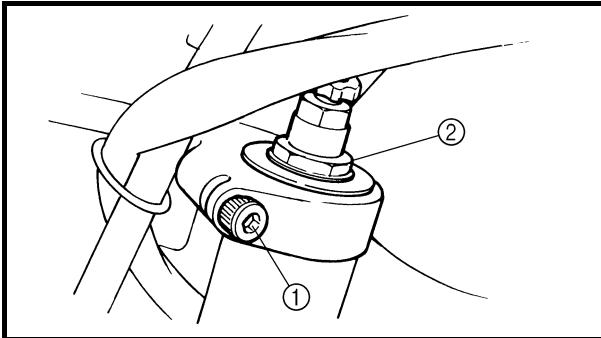

2. Loosen:
 - upper bracket pinch bolt ①
 - cap bolt ②
 - lower bracket pinch bolts ③

⚠ WARNING

Before loosening the upper and lower bracket pinch bolts, support the front fork leg.

3. Remove:
 - front fork leg

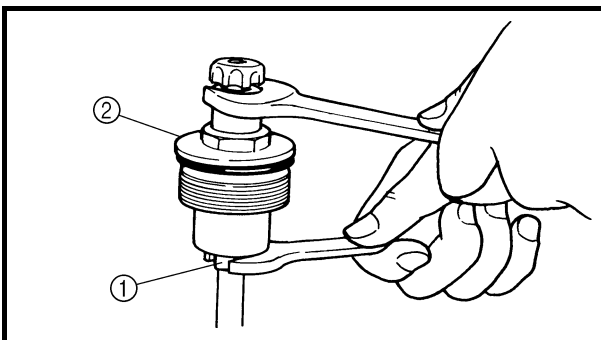

EAS00652

DISASSEMBLING THE FRONT FORK LEGS

The following procedure applies to both of the front fork legs.

1. Loosen:
 - nut ①
 - cap bolt ②
2. Remove:
 - cap bolt
 - nut

3. Drain:
 - fork oil

NOTE:

Stroke the inner tube several times while draining the fork oil.

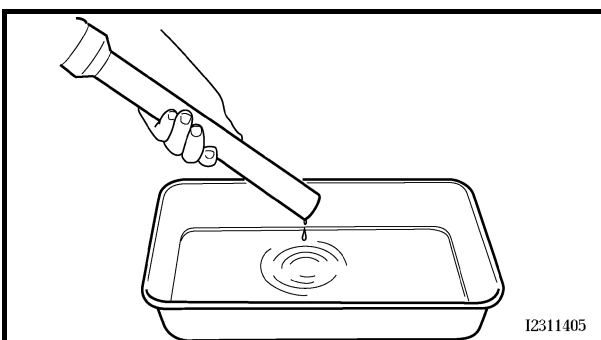

12311405

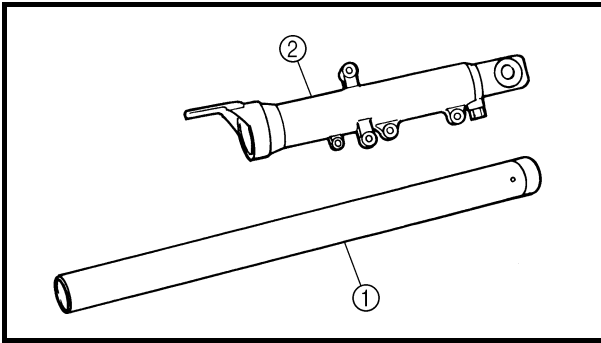

EAS00657

CHECKING THE FRONT FORK LEGS

The following procedure applies to both of the front fork legs.

1. Check:

- inner tube ①
- outer tube ②

Bends/damage/scratches → Replace.

⚠ WARNING

Do not attempt to straighten a bent inner tube as this may dangerously weaken it.

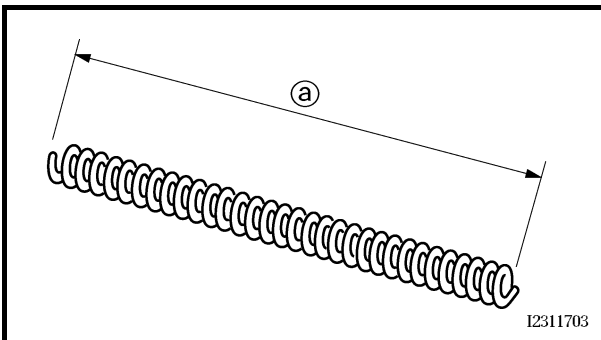

2. Measure:

- spring free length ③

Out of specification → Replace.



Spring free length
261 mm

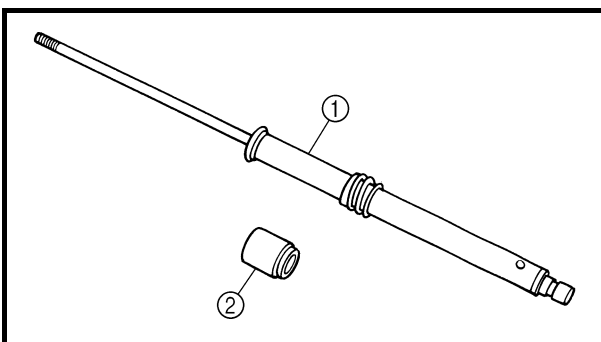

3. Check:

- damper rod ①

Damage/wear → Replace.

Obstruction → Blow out all of the oil passages with compressed air.

- oil flow stopper ②

Damage → Replace.

CAUTION:

- The front fork leg has a built-in damper adjusting rod and a very sophisticated internal construction, which are particularly sensitive to foreign material.
- When disassembling and assembling the front fork leg, do not allow any foreign material to enter the front fork.

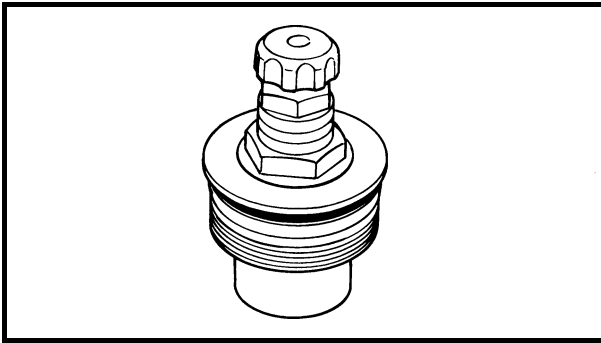

4. Check:
- cap bolt O-ring
Damage/wear → Replace.

EAS00661

ASSEMBLING THE FRONT FORK LEGS

The following procedure applies to both of the front fork legs.

⚠ WARNING

- **Make sure the oil levels in both front fork legs are equal.**
- **Uneven oil levels can result in poor handling and a loss of stability.**

NOTE:

- When assembling the front fork leg, be sure to replace the following parts:
 - inner tube bushing
 - outer tube bushing
 - oil seal
 - dust seal
- Before assembling the front fork leg, make sure all of the components are clean.

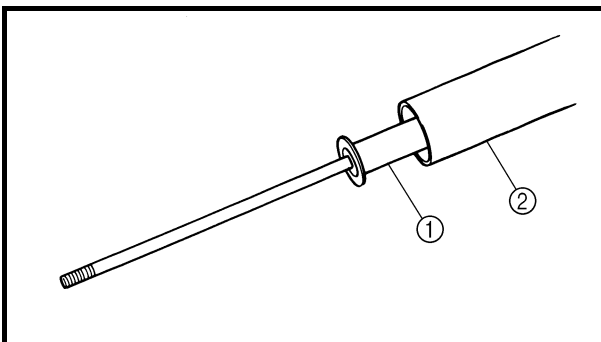

1. Install:
- damper rod assembly ①

CAUTION:

Allow the damper rod assembly to slide slowly down the inner tube ② until it protrudes from the bottom of the inner tube. Be careful not to damage the inner tube.

2. Lubricate:
- inner tube's outer surface



**Recommended lubricant
Yamaha fork and shock oil 01 or
equivalent**

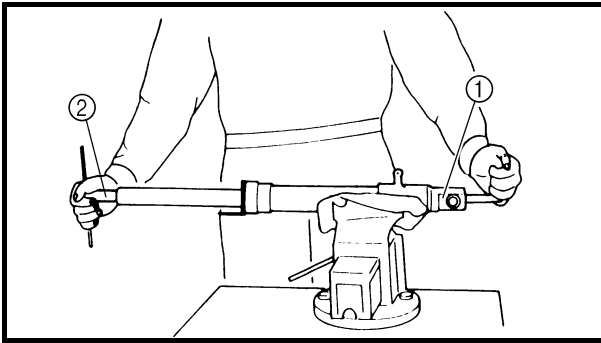

3. Tighten:

- damper rod assembly bolt ①

35 Nm (3.5 m · kg)

NOTE:

- If the washer has not been removed during disassembly, strike the washer lightly, and then remove it.
- While holding the damper rod assembly with the damper rod holder ②, tighten the damper rod assembly bolt.



Damper rod holder
90890-01447

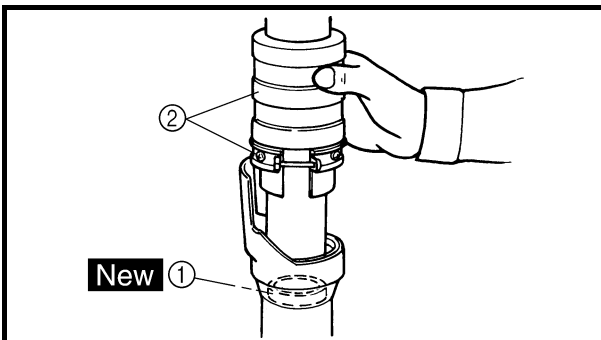

4. Install:

- outer tube bushing ① **New**
(with the fork seal driver ②)



Fork seal driver
90890-01442

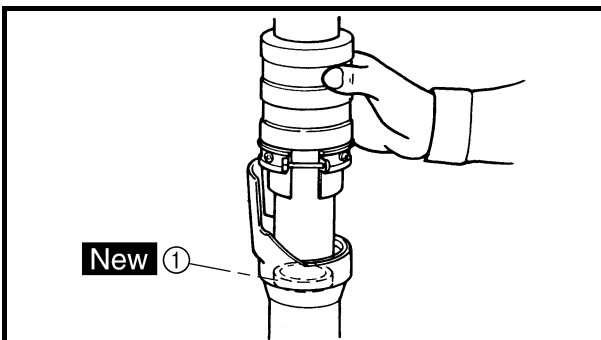

5. Install:

- seal spacer
- oil seal ① **New**
(with the fork seal driver)

CAUTION:

Make sure the numbered side of the oil seal faces up.

NOTE:

- Before installing the oil seal, lubricate its lips with lithium soap base grease.
- Lubricate the outer surface of the inner tube with fork oil.
- Before installing the oil seal, cover the top of the front fork leg with a plastic bag ② to protect the oil seal during installation.

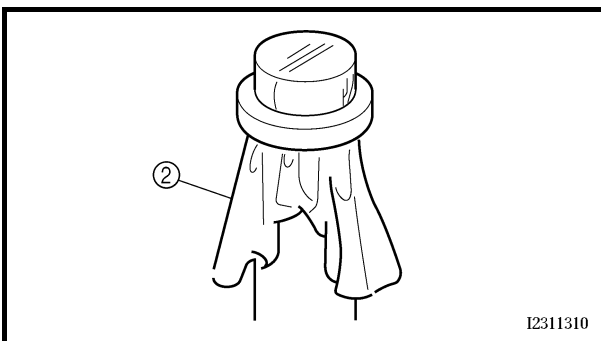

I2311310

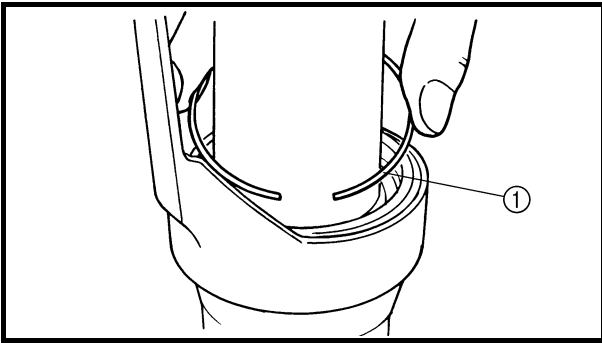

6. Install:
- oil seal clip ①

NOTE: _____
Adjust the oil seal clip so that it fits into the groove of the outer tube.

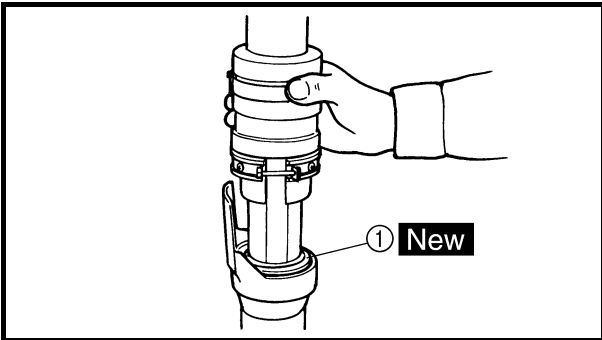

7. Install:
- dust seal ① **New**
(with the fork seal driver)

8. Fully compress the front fork leg.
9. Fill:
- front fork leg
(with the specified amount of the recommended fork oil)

	Quantity (each front fork leg)
	0.7 L
	Recommended oil
	Suspension oil "01" or equivalent

CAUTION: _____

- Be sure to use the recommended fork oil. Other oils may have an adverse effect on front fork performance.
- When disassembling and assembling the front fork leg, do not allow any foreign material to enter the front fork.

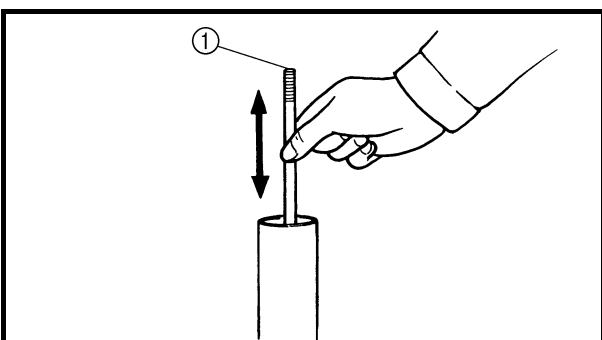

10. After filling the front fork leg, slowly stroke the damper rod ① up and down (at least ten times) to distribute the fork oil.

NOTE: _____
Be sure to stroke the damper rod slowly because the fork oil may spurt out.

EAS00662

INSTALLING THE FRONT FORK LEGS

The following procedure applies to both of the front fork legs.

1. Install:
 - front fork leg

NOTE:

- Make sure that the inner tube end is flush with the top of the upper bracket.
- Temporarily tighten the upper and lower bracket pinch bolts.

⚠ WARNING

Make sure the brake hoses are routed properly.

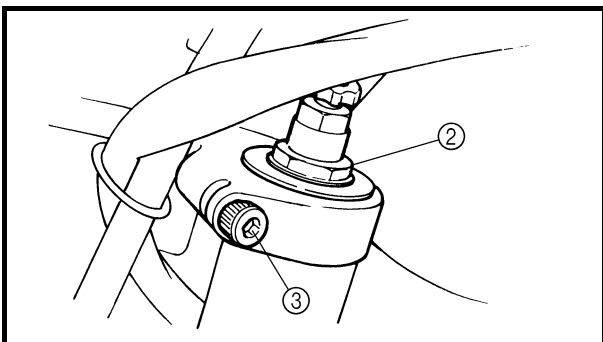
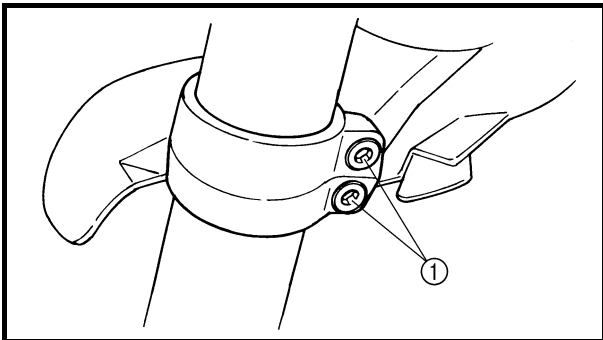

2. Tighten:

- lower bracket pinch bolts ①

	23 Nm (2.3 m · kg)
---	---------------------------

- cap bolt ②

	25 Nm (2.5 m · kg)
---	---------------------------

- upper bracket pinch bolt ③

	34 Nm (3.4 m · kg)
---	---------------------------

3. Adjust:

- spring preload
- rebound damping
- compression damping

Refer to “ADJUSTING THE FRONT FORK LEGS” in chapter 3.

EAS00665

HANDLEBARS
LEFT HANDLEBAR

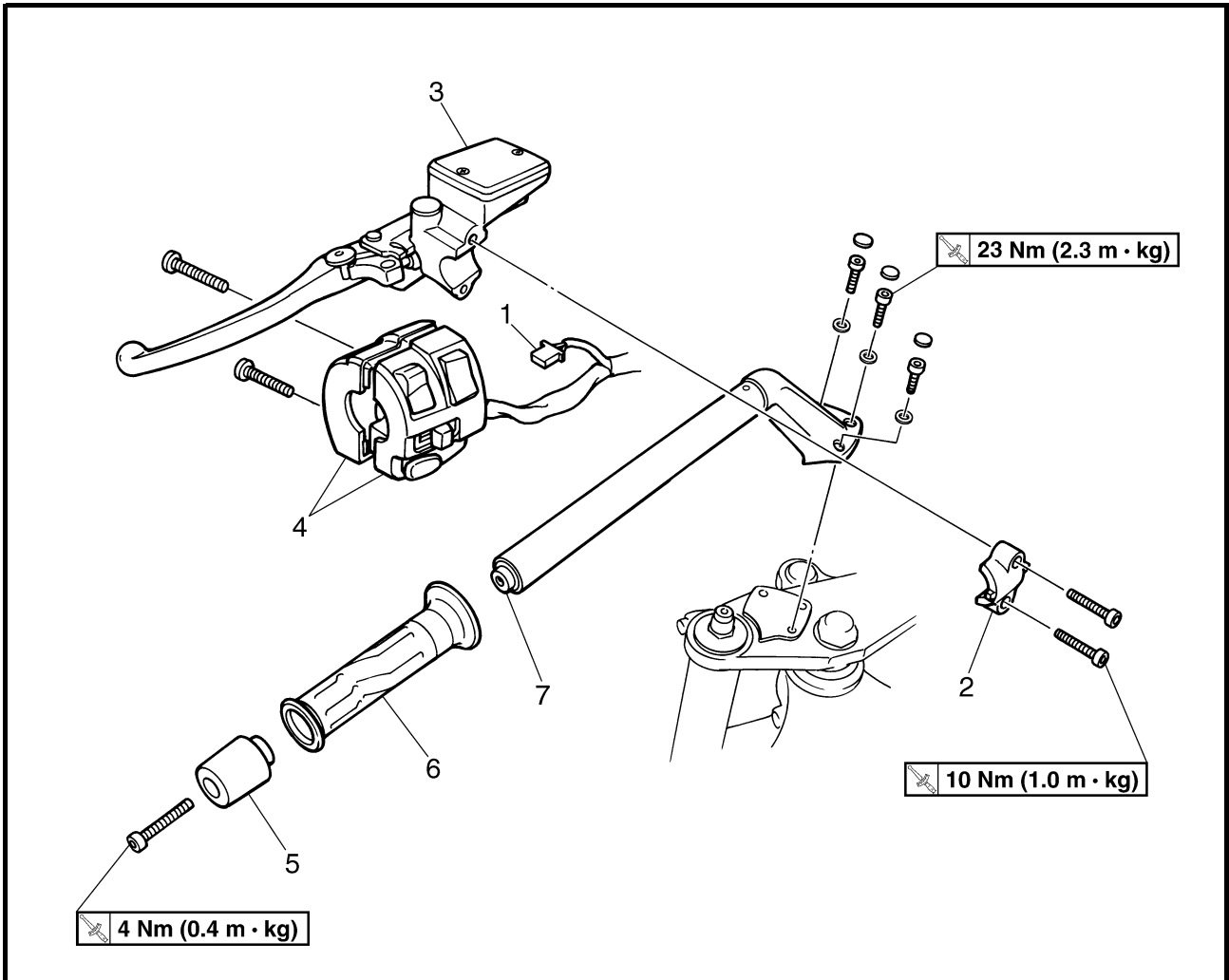

Order	Job/Part	Q'ty	Remarks
	Removing the left handlebar		Remove the parts in the order listed.
1	Clutch switch coupler	1	Disconnect.
2	Clutch master cylinder holder	1	Refer to "REMOVING/INSTALLING THE HANDLEBARS".
3	Clutch master cylinder	1	
4	Left handlebar switch	1	
5	Grip end	1	
6	Handlebar grip	1	
7	Left handlebar	1	

RIGHT HANDLEBAR

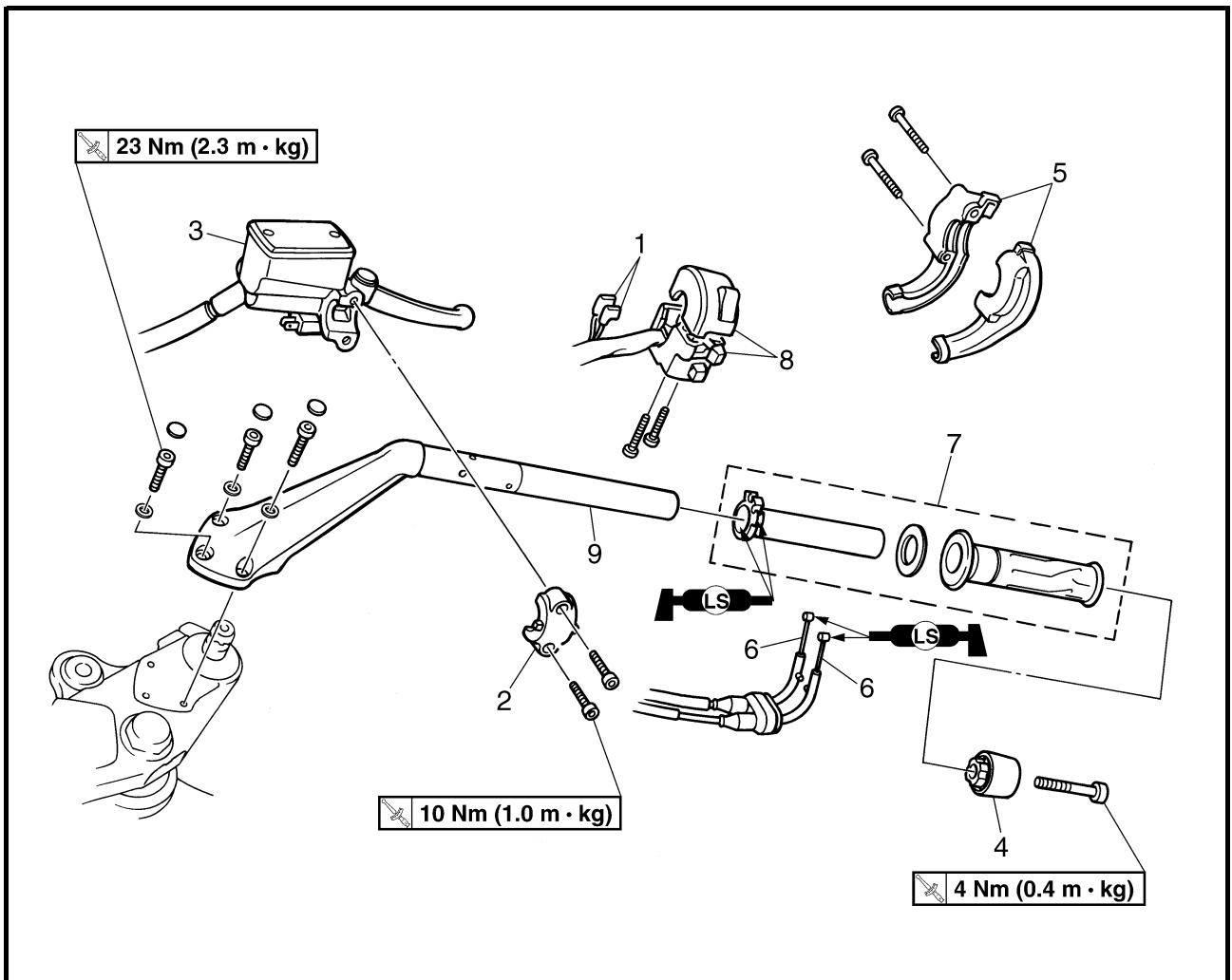

Order	Job/Part	Q'ty	Remarks
	Removing the right handlebar		Remove the parts in the order listed.
1	Front brake light switch connector	2	Disconnect. Refer to "REMOVING/ INSTALLING THE HANDLEBARS".
2	Brake master cylinder holder	1	
3	Brake master cylinder	1	
4	Grip end	1	
5	Throttle cable housing	1	
6	Throttle cable	2	
7	Throttle grip	1	
8	Right handlebar switch	1	
9	Right handlebar	1	
			For installation, reverse the removal procedure.



EAS00667

REMOVING THE HANDLEBARS

1. Stand the motorcycle on a level surface.

⚠ WARNING

Securely support the motorcycle so that there is no danger of it falling over.

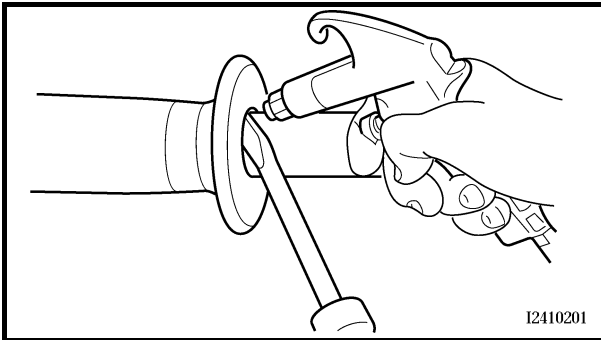

2. Remove:
 - handlebar grip

NOTE:

Blow compressed air between the left handlebar and the handlebar grip, and gradually push the grip off the handlebar.

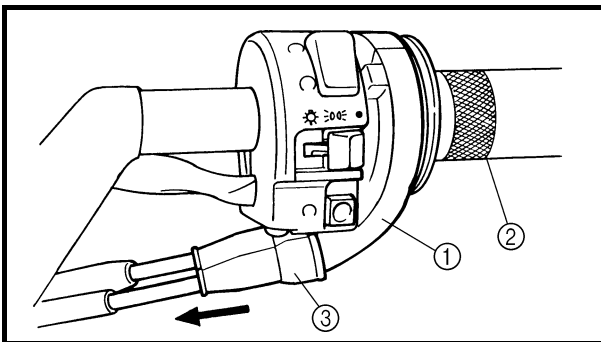

3. Remove:
 - throttle cable housing ①
 - throttle grip ②

NOTE:

While removing the throttle cable housing, pull back the rubber cover ③.

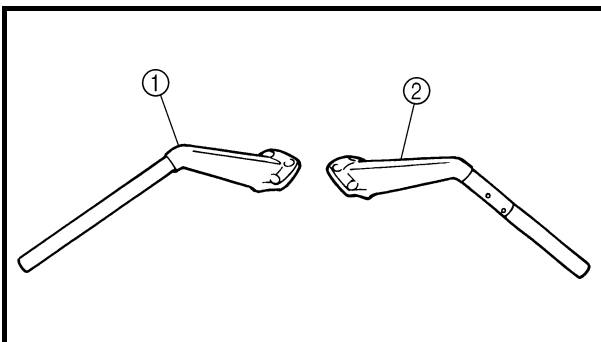

EAS00669

CHECKING THE HANDLEBARS

1. Check:
 - left handlebar ①
 - right handlebar ②

Bends/cracks/damage → Replace.

⚠ WARNING

Do not attempt to straighten bent handlebars as this may dangerously weaken them.



EAS00674

INSTALLING THE HANDLEBARS

1. Stand the motorcycle on a level surface.

⚠ WARNING

Securely support the motorcycle so that there is no danger of it falling over.

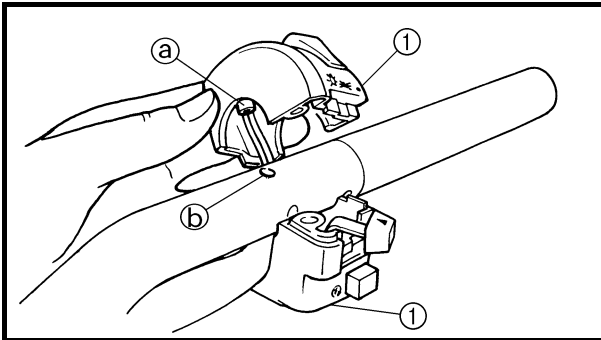

2. Install:

- right handlebar switch ①

NOTE:

Align the projection ① on the right handlebar switch with the hole ② in the right handlebar.

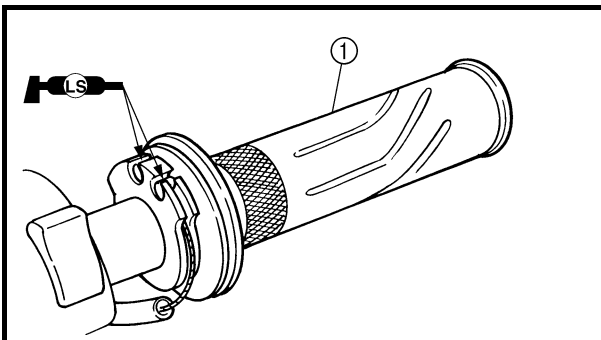

3. Install:

- throttle grip ①
- throttle cable housing ②
- throttle cables
- grip end

4 Nm (0.4 m · kg)

NOTE:

- Lubricate the inside of the throttle grip with a thin coat of lithium soap base grease and install it onto the handlebar.
- Align the projection ① on the throttle cable housing with the hole ② in the right handlebar.
- There should be 1 ~ 3 mm of clearance ③ between the throttle grip and the grip end.

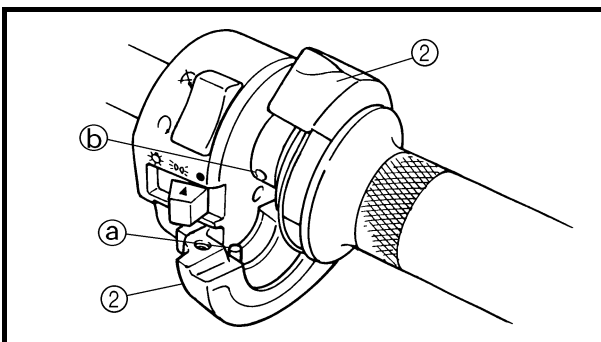

⚠ WARNING

Make sure the throttle grip operates smoothly.

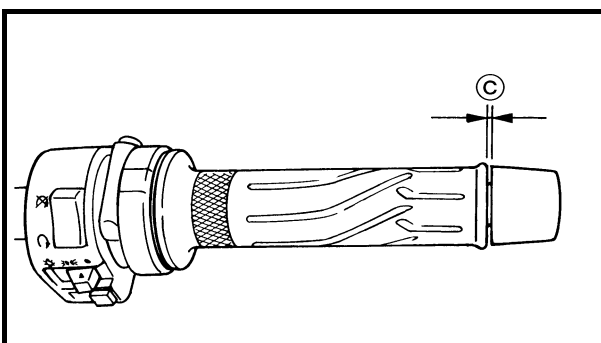

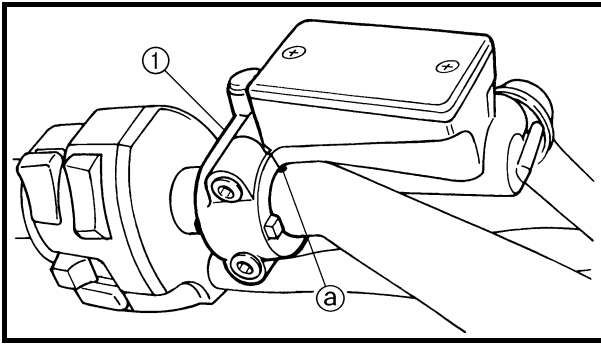

7. Install:

- clutch master cylinder
- clutch master cylinder holder ①

10 Nm (1.0 m · kg)

NOTE:

Align the slit in the clutch master cylinder holder with the punch mark (a) in the left handlebar.

8. Adjust:

- throttle cable free play
Refer to “ADJUSTING THE THROTTLE CABLE FREE PLAY” in chapter 3.



Throttle cable free play (at the flange of the throttle grip)
3 ~ 5 mm

EAS00676

STEERING HEAD

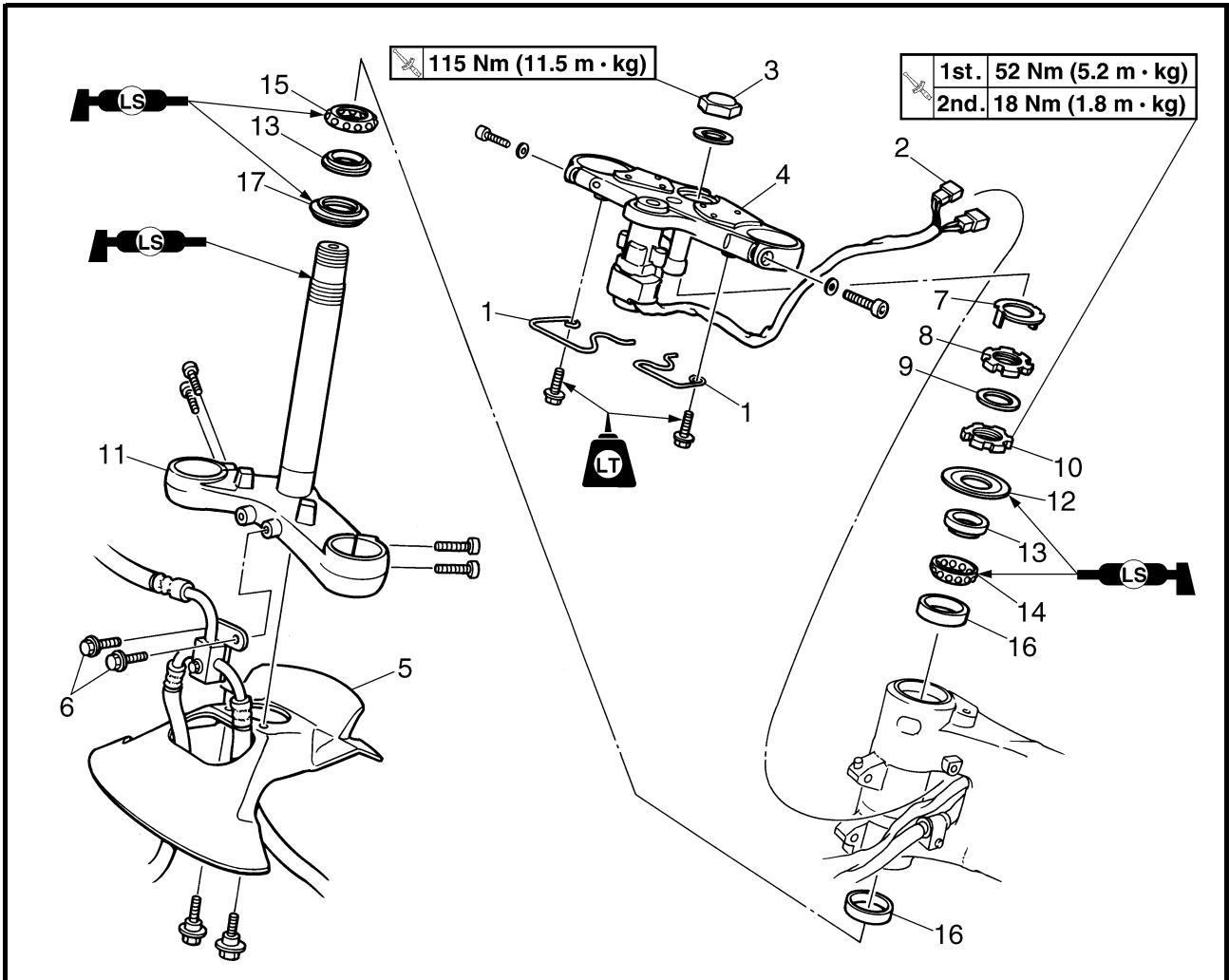

Order	Job/Part	Q'ty	Remarks
	Removing the lower bracket		Remove the parts in the order listed.
	Front wheel		Refer to "FRONT WHEEL AND BRAKE DISCS".
	Front fork legs		Refer to "FRONT FORK".
	Handlebars		Refer to "HANDLEBARS".
1	Lead guide	2	
2	Main switch coupler	2	Disconnect.] Refer to "INSTALLING THE STEERING HEAD".
3	Steering stem nut	1	
4	Upper bracket	1	
5	Lower bracket panel	1	
6	Brake hose holding bolt	2	

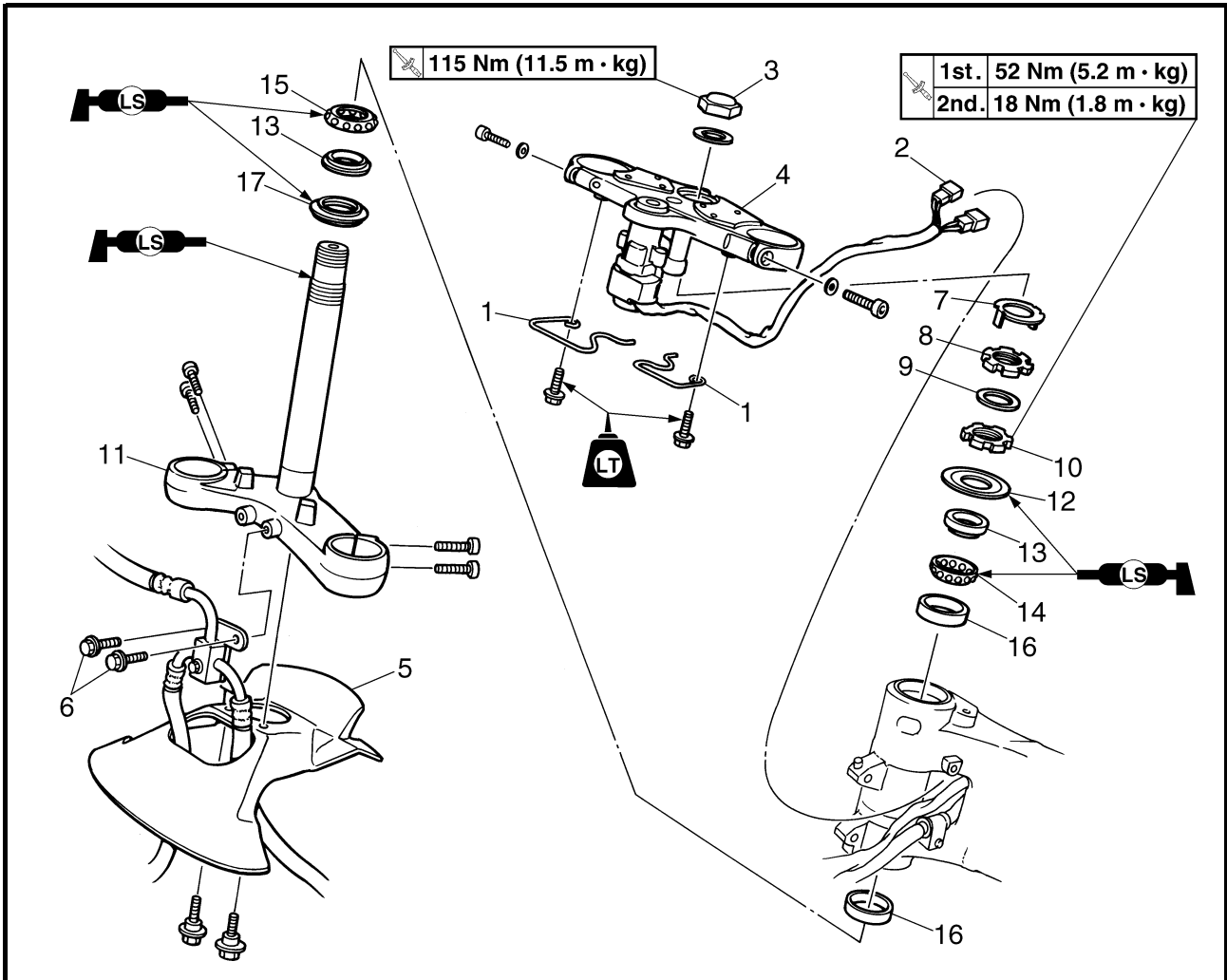

Order	Job/Part	Q'ty	Remarks
7	Lock washer	1	Refer to "REMOVING THE LOWER BRACKET" and "INSTALLING THE STEERING HEAD".
8	Upper ring nut	1	
9	Rubber washer	1	
10	Lower ring nut	1	
11	Lower bracket	1	
12	Bearing cover	1	
13	Bearing inner race	2	
14	Upper bearing	1	
15	Lower bearing	1	
16	Bearing outer race	2	For installation, reverse the removal procedure.
17	Dust seal	1	

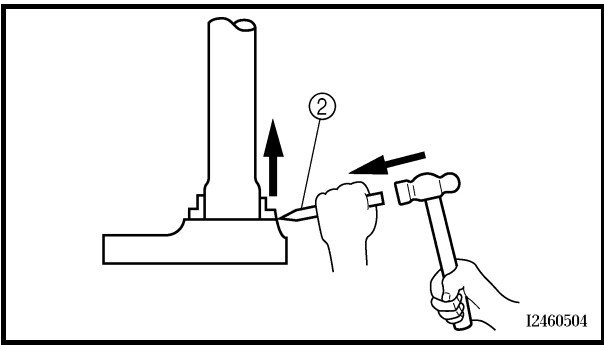

- b. Remove the bearing race from the lower bracket with a floor chisel ② and hammer.
- c. Install a new rubber seal and new bearing races.

CAUTION:

If the bearing race is not installed properly, the steering head pipe could be damaged.

NOTE:

- Always replace the bearings and bearing races as a set.
- Whenever the steering head is disassembled, replace the rubber seal.



4. Check:

- upper bracket
- lower bracket (along with the steering stem)
Bends/cracks/damage → Replace.

EAS00683

INSTALLING THE STEERING HEAD

1. Lubricate:

- upper bearing
- lower bearing
- bearing races

	Recommended lubricant Lithium soap base grease
---	---

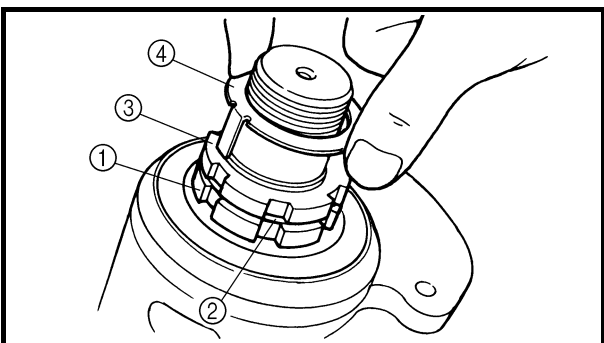

2. Install:

- lower ring nut ①
- rubber washer ②
- upper ring nut ③
- lock washer ④

Refer to "CHECKING AND ADJUSTING THE STEERING HEAD" in chapter 3.



3. Install:
- upper bracket
 - steering stem nut

NOTE:

Temporarily tighten the steering stem nut.

4. Install:
- front fork legs
- Refer to "FRONT FORK".

NOTE:

Temporarily tighten the lower and upper bracket pinch bolts.

5. Tighten:
- steering stem nut

 **115 Nm (11.5 m · kg)**

REAR SHOCK ABSORBER ASSEMBLY AND RELAY ARM



EAS00685

REAR SHOCK ABSORBER ASSEMBLY AND RELAY ARM

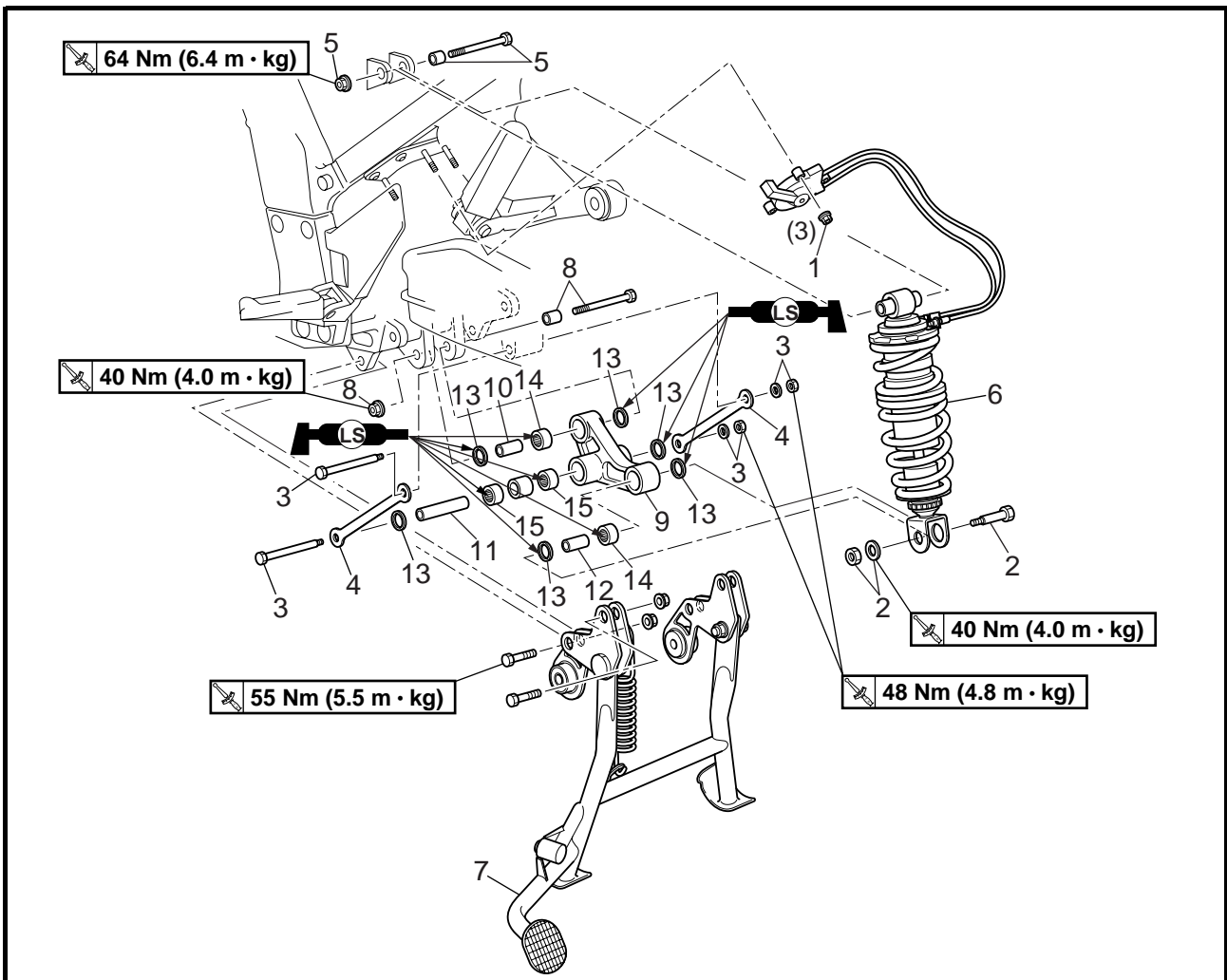

Order	Job/Part	Q'ty	Remarks	
	Removing the rear shock absorber assembly and relay arm		Remove the parts in the order listed.	
	Rear wheel		Refer to "REAR WHEEL AND BRAKE DISC".	
	Mufflers/exhaust pipe		Refer to "ENGINE" in chapter 5.	
1	Nut	3	Refer to "REMOVING/INSTALLING THE REAR SHOCK ABSORBER ASSEMBLY".	
2	Nut/washer/bolt	1/1/1		Bolt $\ell = 54$ mm
3	Nut/washer/bolt	2/2/2		Bolt $\ell = 117$ mm
4	Connecting arm	2		
5	Nut/bolt/spacer	1/1/1		Bolt $\ell = 105$ mm
6	Rear shock absorber assembly	1		
7	Centerstand	1		
8	Nut/bolt/spacer	1/1/1	Bolt $\ell = 76$ mm	
9	Relay arm	1		
10	Collar	1		

REAR SHOCK ABSORBER ASSEMBLY AND RELAY ARM

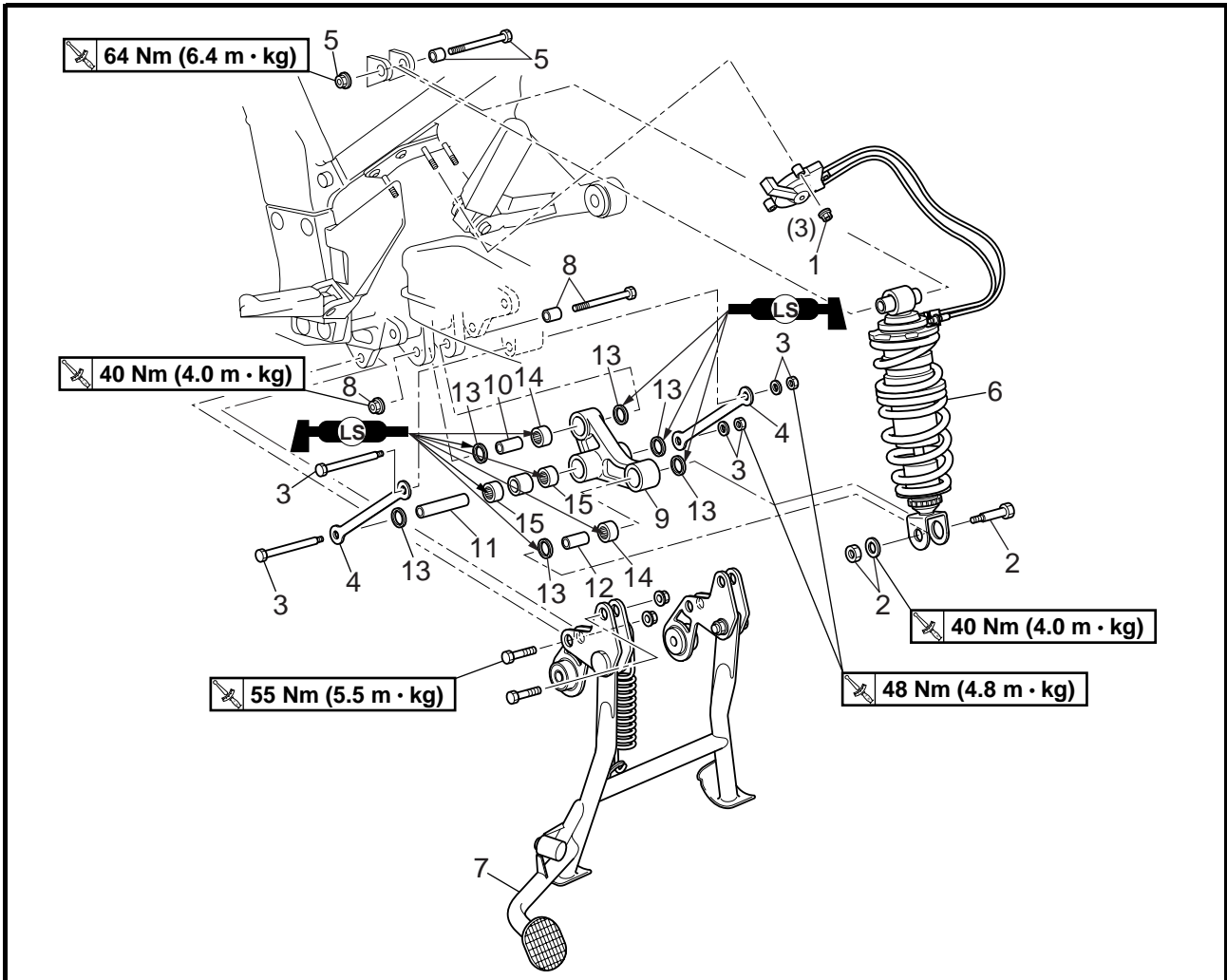

Order	Job/Part	Q'ty	Remarks
11	Collar	1	Refer to "INSTALLING THE RELAY ARM". For installation, reverse the removal procedure.
12	Collar	1	
13	Oil seal	6	
14	Bearing	2	
15	Bearing	2	

EAS00686

HANDLING THE REAR SHOCK ABSORBER

⚠ WARNING

This rear shock absorber contains highly compressed nitrogen gas. Before handling the rear shock absorber, read and make sure you understand the following information. The manufacturer cannot be held responsible for property damage or personal injury that may result from improper handling of the rear shock absorber.

- Do not tamper or attempt to open the rear shock absorber.
- Do not subject the rear shock absorber to an open flame or any other source of high heat. High heat can cause an explosion due to excessive gas pressure.
- Do not deform or damage the rear shock absorber in any way. Rear shock absorber damage will result in poor damping performance.

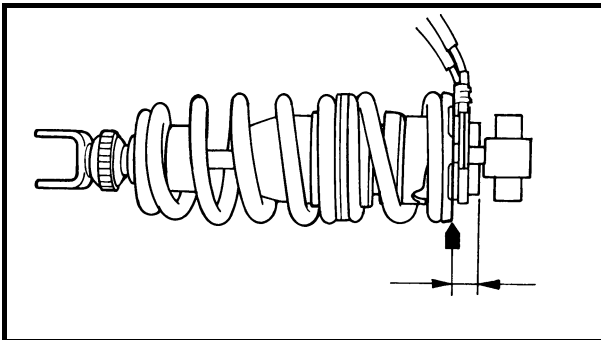

EAS00688

DISPOSING OF A REAR SHOCK ABSORBER

Gas pressure must be released before disposing of a rear shock absorber. To release the gas pressure, drill a 2 ~ 3-mm hole through the rear shock absorber at a point 15 ~ 20 mm from its end as shown.

⚠ WARNING

Wear eye protection to prevent eye damage from released gas or metal chips.

EAS00694

REMOVING THE REAR SHOCK ABSORBER ASSEMBLY

1. Stand the motorcycle on a level surface.

⚠ WARNING

Securely support the motorcycle so that there is no danger of it falling over.

NOTE:

Place the motorcycle on a suitable stand so that the rear wheel is elevated.

REAR SHOCK ABSORBER ASSEMBLY AND RELAY ARM

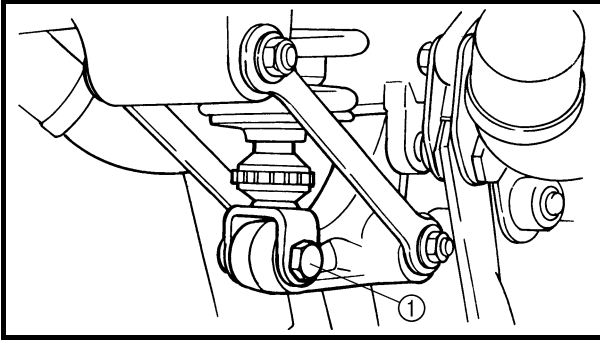
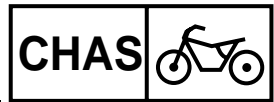

2. Remove:
- rear shock absorber assembly lower bolt ①
 - connecting arms

NOTE: _____
While removing the connecting arm bolt, hold the swingarm so that it does not drop down.

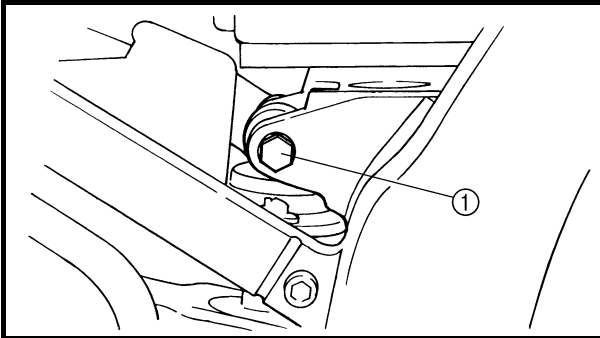

3. Remove:
- rear shock absorber assembly upper bolt ①
 - rear shock absorber assembly

NOTE: _____
Raise the swingarm and then remove the rear shock absorber assembly from between the swingarm and relay arm.

EAS00695

CHECKING THE REAR SHOCK ABSORBER ASSEMBLY

1. Check:
- rear shock absorber rod
Bends/damage → Replace the rear shock absorber assembly.
 - rear shock absorber
Gas leaks/oil leaks → Replace the rear shock absorber assembly.
 - spring
Damage/wear → Replace the rear shock absorber assembly.
 - bolts
Bends/damage/wear → Replace.

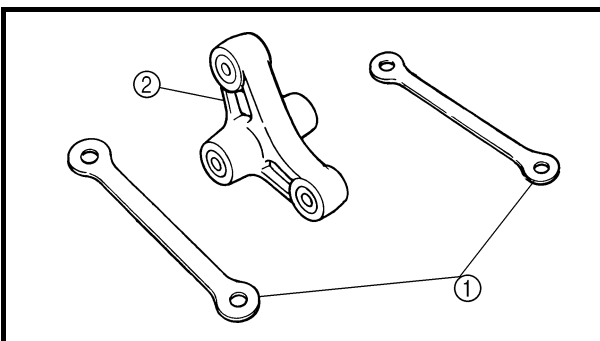

CHECKING THE CONNECTING ARM AND RELAY ARM

1. Check:
- connecting arms ①
 - relay arm ②
Damage/wear → Replace.

2. Check:
 - bearings
 - oil seals
 Damage/pitting → Replace.
3. Check:
 - spacers
 Damage/scratches → Replace.

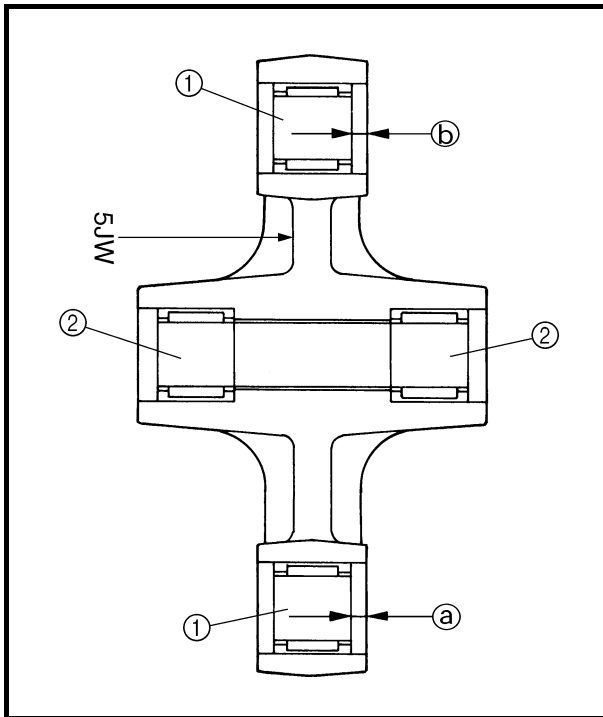

INSTALLING THE RELAY ARM

1. Lubricate:
 - spacers
 - bearings

	Recommended lubricant Lithium soap base grease
---	--

2. Install:
 - bearing ①, ②
(to the relay arm)

	Installed depth ① 4.0 mm
	Installed depth ② 4.5 mm

EAS00698

INSTALLING THE REAR SHOCK ABSORBER ASSEMBLY

1. Lubricate:
 - spacers
 - bearings

	Recommended lubricant Lithium soap base grease
---	--

2. Install:
 - rear shock absorber assembly

NOTE: _____
When installing the rear shock absorber assembly, lift up the swingarm.



EAS00701

SWINGARM

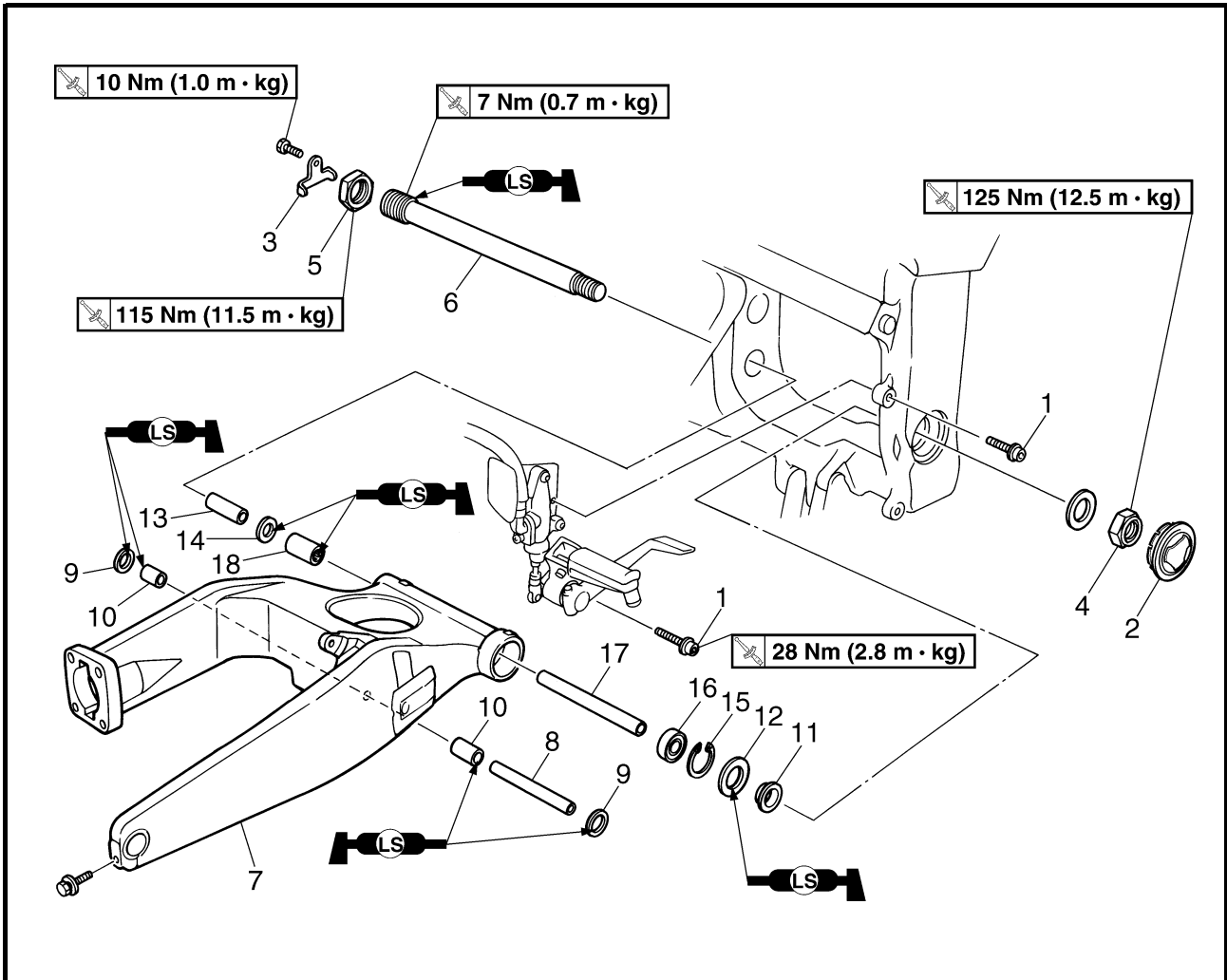

Order	Job/Part	Q'ty	Remarks
	Removing the swingarm		Remove the parts in the order listed.
	Mufflers		Refer to "ENGINE" in chapter 5.
	Rear wheel		Refer to "REAR WHEEL AND BRAKE DISC".
	Final drive assembly/universal joint		Refer to "SHAFT DRIVE".
	Rear shock absorber assembly		Refer to "REAR SHOCK ABSORBER ASSEMBLY AND RELAY ARM".
1	Right footrest bracket bolt	2	Refer to "REMOVING THE SWINGARM".
2	Cover	1	
3	Cover	1	
4	Pivot shaft nut	1	
5	Locknut	1	
6	Pivot shaft	1	
7	Swingarm	1	
8	Spacer	1	

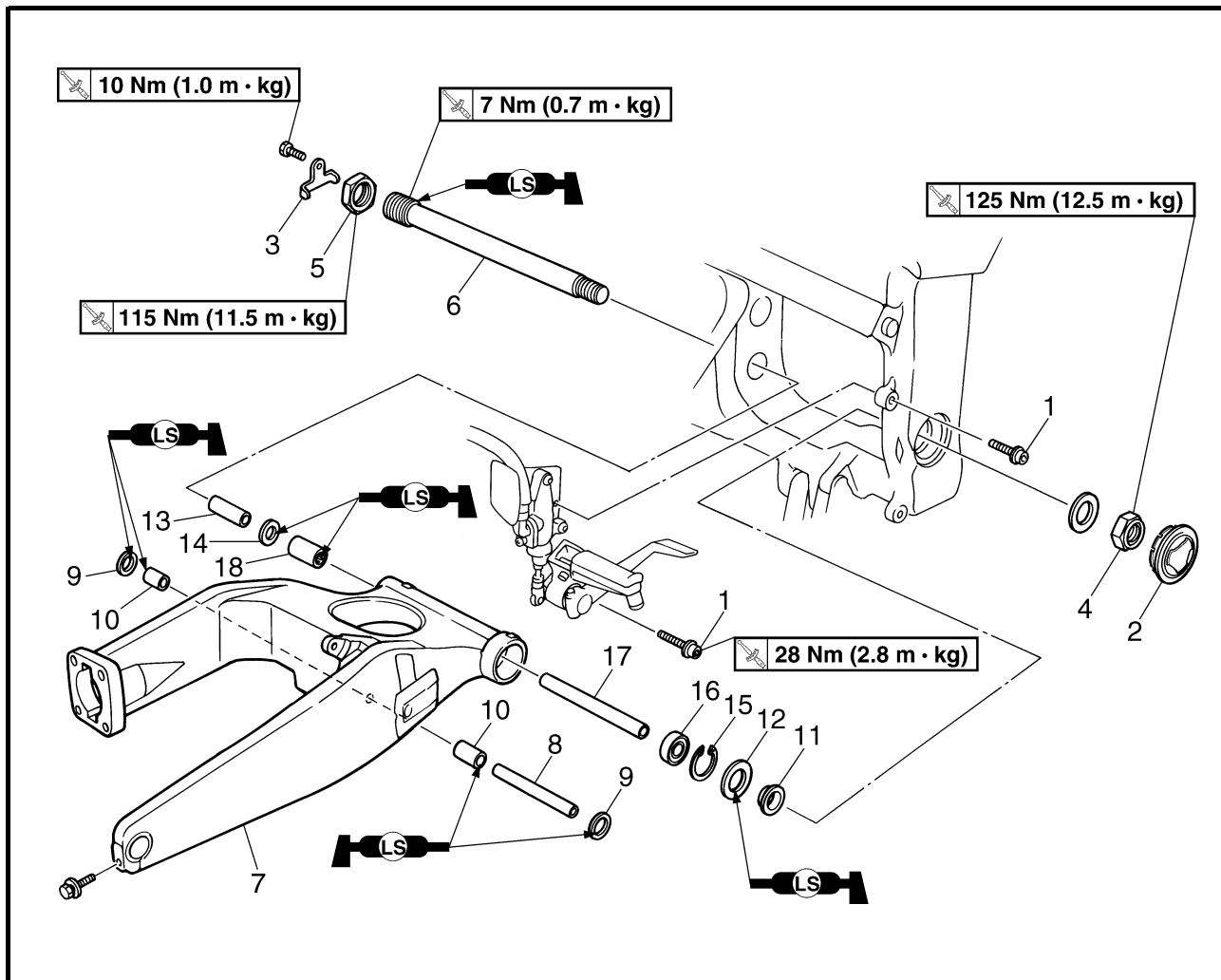

Order	Job/Part	Q'ty	Remarks	
9	Oil seal	2	Refer to "INSTALLING THE SWINGARM".	
10	Bearing	2		
11	Spacer	1		
12	Oil seal	1		
13	Bushing	1		
14	Oil seal	1		
15	Circlip	1		
16	Bearing	1		
17	Spacer	1		
18	Bearing	1		
				Refer to "INSTALLING THE SWINGARM".
				For installation, reverse the removal procedure.

EAS00702

REMOVING THE SWINGARM

1. Stand the motorcycle on a level surface.

! WARNING

Securely support the motorcycle so that there is no danger of it falling over.

NOTE:

Place the motorcycle on a suitable stand so that the rear wheel is elevated.

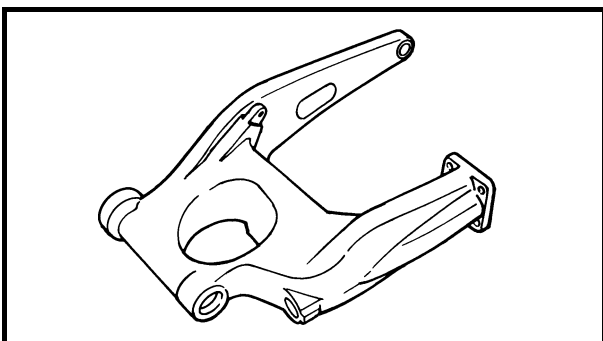
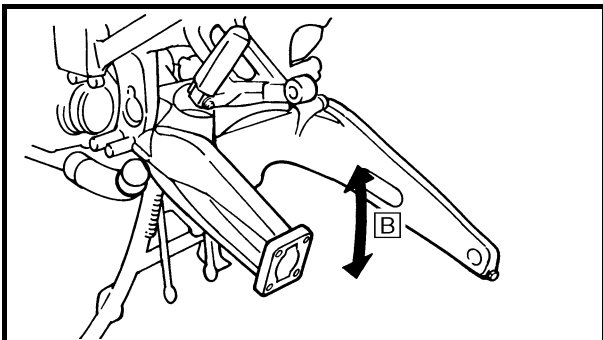
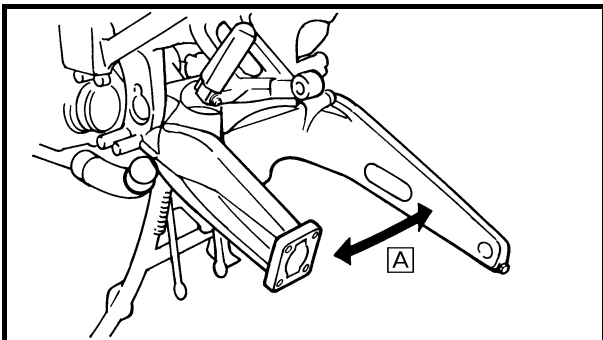

2. Measure:

- swingarm side play
- swingarm vertical movement



- a. Measure the tightening torque of the swingarm pivot shaft, pivot shaft nut and locknut.

	Pivot shaft nut 125 Nm (12.5 m · kg)
	Locknut 115 Nm (11.5 m · kg)
	Pivot shaft 7 Nm (0.7 m · kg)

- b. Measure the swingarm side play [A] by moving the swingarm from side to side.
- c. If the swingarm side play is out of specification, check the spacers, bushing and bearings.

	Swingarm side play (at the end of the swingarm) 0 mm
---	---

- d. Check the swingarm vertical movement [B] by moving the swingarm up and down.
If swingarm vertical movement is not smooth or if there is binding, check the spacers, bushing and bearings.



EAS00707

CHECKING THE SWINGARM

1. Check:

- swingarm
- Bends/cracks/damage → Replace.

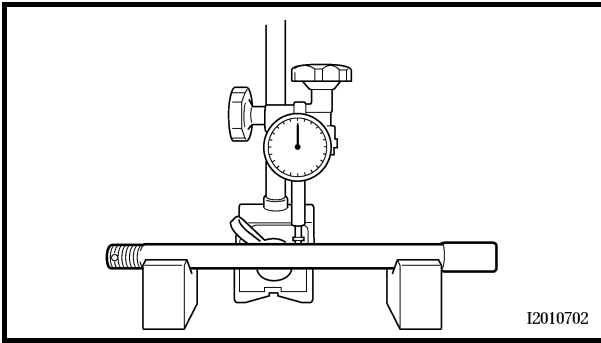

2. Check:
- pivot shaft
Roll the pivot shaft on a flat surface.
Bends → Replace.

⚠ WARNING

Do not attempt to straighten a bent pivot shaft.

3. Wash:
- pivot shaft
 - spacers
 - bushing
 - bearings

	Recommended cleaning solvent Kerosene
---	---

4. Check:
- spacers
 - bushing
 - oil seals
Damage/wear → Replace.
 - bearings
Damage/pitting → Replace.

EAS00712

INSTALLING THE SWINGARM

1. Lubricate:
- bearings
 - spacers
 - oil seals
 - pivot shaft

	Recommended lubricant Lithium soap base grease
---	--

2. Install:
- bearing ①
(to the swingarm)

	Installed depth ② 7.0 mm
---	------------------------------------

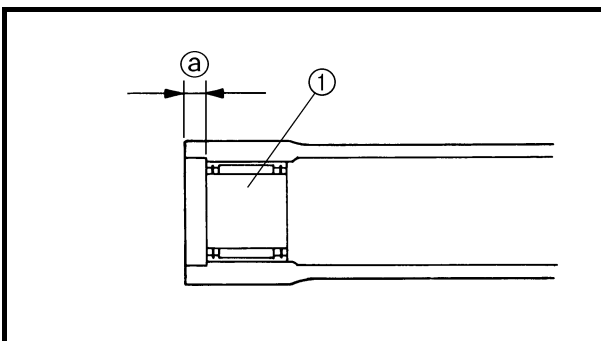

SWINGARM

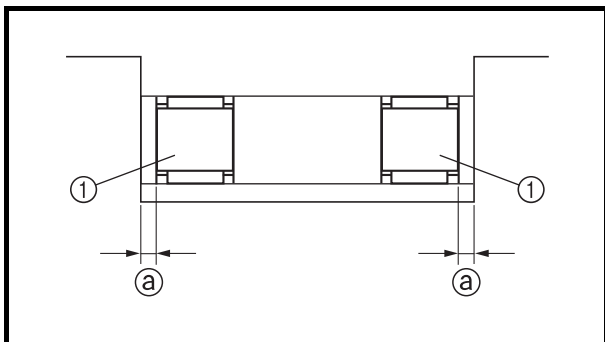

3. Install:
- bearing ①
(to the swingarm)



Installed depth ②
4.0 mm



EAS00715

SHAFT DRIVE TROUBLESHOOTING

A	Symptom	B	Possible cause
1. 2. 3.	<p>1. A pronounced hesitation or jerky movement during acceleration, deceleration or sustained speeds. (not to be confused with engine surging or transmission-related movements.)</p> <p>2. A rolling "rumble" noticeable at low speeds, a high-pitched whine or a "clunk" from a shaft drive component, or from the vicinity of the shaft drive.</p> <p>3. The shaft drive is locked up or no power is transmitted from the engine to the rear wheel.</p>		<p>A. Bearing damage</p> <p>B. Improper gear backlash</p> <p>C. Damaged gear teeth</p> <p>D. Broken drive shaft</p> <p>E. Broken gear teeth</p> <p>F. Seizure due to lack of lubrication</p> <p>G. Small foreign objects lodged between moving parts</p>

NOTE:

Causes A, B, and C may be extremely difficult to diagnose. The symptoms are quite subtle and difficult to distinguish from normal operating noises. If there is reason to believe that these components are damaged, remove them and check them individual.



Inspection notes

- 1. Investigate any unusual noises.



The following noises may indicate a mechanical defect:

- a. A rolling “rumble” during coasting, acceleration or deceleration (increases with the rear wheel speed, but does not increase with higher engine or transmission speeds).
Diagnosis: Possible wheel bearing damage
- b. A whining noise that varies with acceleration and deceleration.
Diagnosis: Possible incorrect reassembly or too little gear backlash

⚠ WARNING

Insufficient gear backlash is extremely destructive to the gear teeth. If a test ride, following reassembly, indicates these symptoms, stop riding immediately to minimize gear damage.

- c. A slight “clunk” evident at low speed operation (not to be confused with normal motorcycle operation).
Diagnosis: Possible broken gear teeth

⚠ WARNING

Stop riding immediately if broken gear teeth are suspected. This condition could result in the shaft drive assembly locking up, causing a loss of control and possible injury to the rider.





EAS00716

Troubleshooting chart

When causes (A) or (B) shown in the table at the beginning of the "TROUBLESHOOTING" section exist, check the following points.

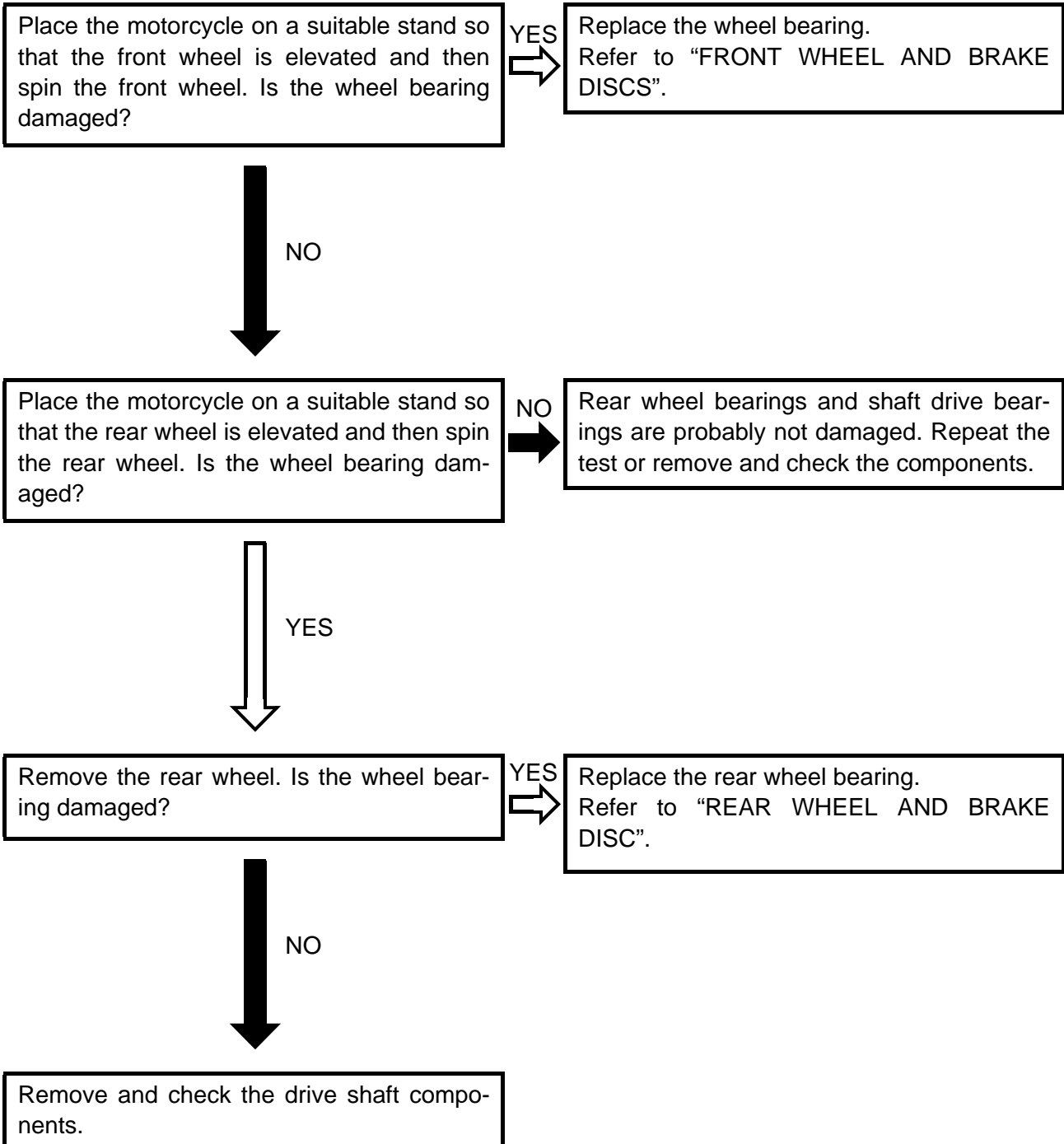

EAS00717

CHECKING THE FINAL DRIVE OIL FOR CONTAMINATION AND CHECKING THE SHAFT DRIVE FOR LEAKS

1. Drain:

- final drive oil (from the final drive housing)

Refer to “CHANGING THE FINAL DRIVE OIL” in chapter 3.

2. Check:

- final drive oil
Large amount of metal particles → Check for bearing seizure.

NOTE:

A small amount of metal particles in the final drive oil is normal.

3. Check:

- shaft drive housing (for oil leaks)

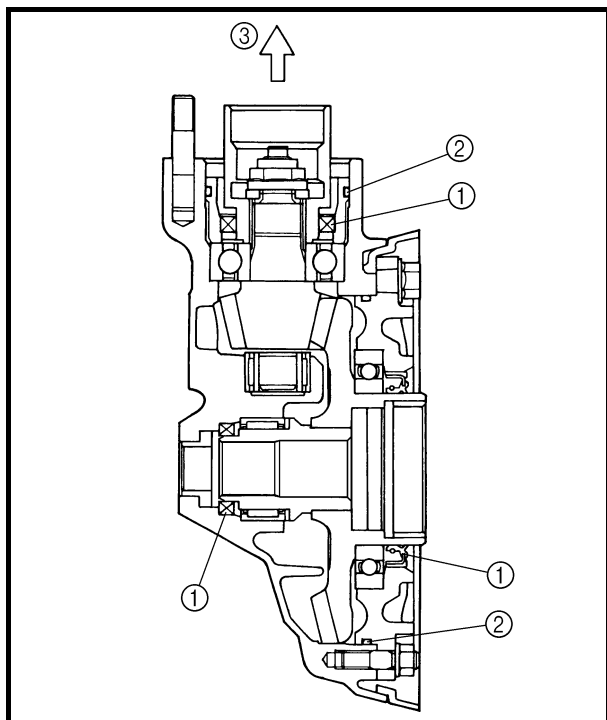

- a. Thoroughly clean the entire motorcycle and then completely dry it.
- b. Apply a leak-locating compound or dry powder spray to the shaft drive.
- c. Test ride the motorcycle long enough to locate a leak.

Oil leak → Repair or replace the faulty part(s).

- ① Oil seal
- ② O-ring
- ③ Forward

NOTE:

- What may appear to be an oil leak on a new or fairly new motorcycle, may result from the application of a rust preventive coating or excessive seal lubrication.
- Always clean the motorcycle and recheck the area where the leak is thought to originate from.



EAS00719

MEASURING THE RING GEAR BACKLASH

1. Secure the final drive assembly in a vise.
2. Remove:
 - final drive oil drain bolt
3. Drain:
 - final drive oil
(from the final drive assembly)

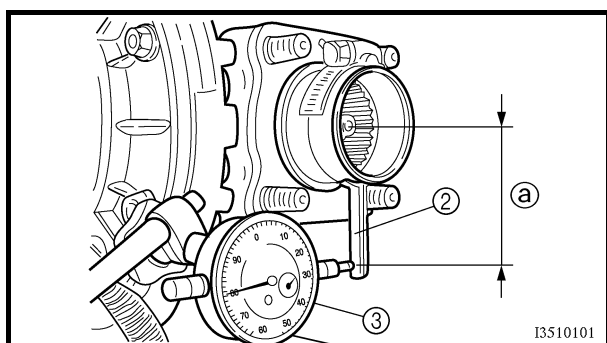
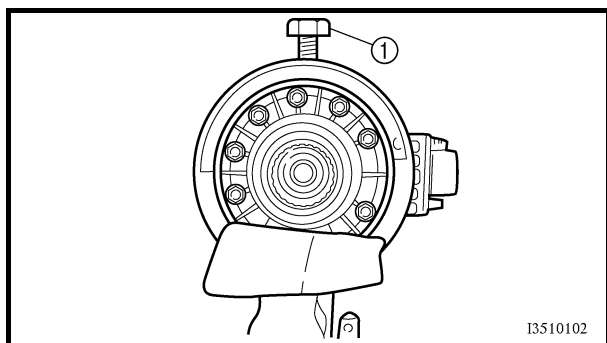
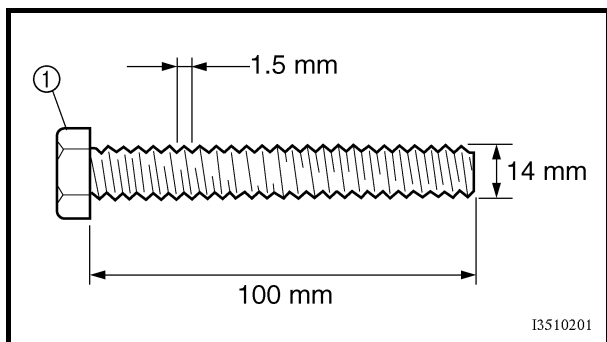

4. Measure:
 - ring gear backlash
Out of specification → Adjust.

	<p>Ring gear backlash 0.25 ~ 0.45 mm</p>
---	---

- a. Install a bolt ① of the specified size, into the final drive oil filler hole.
- b. Finger tighten the bolt until it stops the ring gear from moving.

NOTE:

Do not overtighten the bolt.

- c. Install the final gear backlash band ② and dial gauge ③.

	<p>Final gear backlash band 90890-01230</p>
---	--

- a. Dial-gauge-plunger contact point 60 mm
- d. Gently rotate the gear coupling from engagement to engagement.
- e. Record the reading on the dial gauge.
- f. Remove the dial gauge, final gear backlash band, and bolt.
- g. Rotate the final drive pinion gear 90°.
- h. Reinstall the bolt, special tool, and dial gauge.
- i. Repeat steps (d) to (h) three more times (for a total of four measurements).
- j. If any of the readings are over specification, adjust the ring gear backlash.

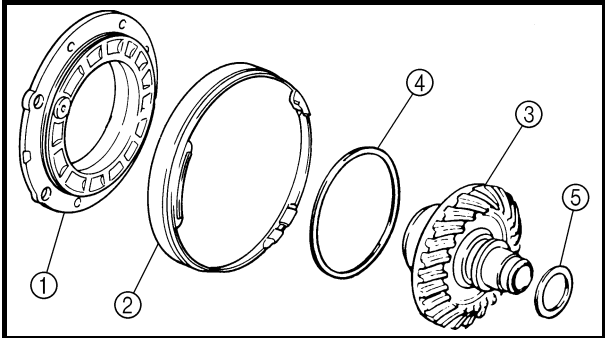
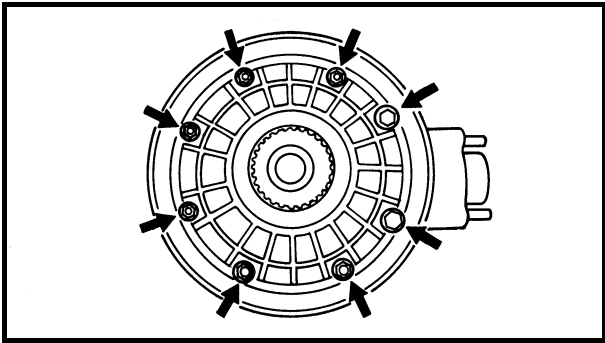

EAS00720

ADJUSTING THE RING GEAR BACKLASH

1. Remove:

- ring gear bearing housing nuts
- ring gear bearing housing bolts

NOTE:

Working in a crisscross pattern, loosen each nut 1/4 of a turn. After all of the nuts are fully loosened, remove them and the bolts.

2. Remove:

- ring gear bearing housing ①
- dust cover ②
- ring gear ③
- ring gear shim(s) ④
- thrust washer ⑤



3. Adjust:

- ring gear backlash

a. Select the suitable shim(s) and thrust washer with the following chart.

Thinner shim	Ring gear backlash is increased.
Thicker shim	Ring gear backlash is decreased.

- b. If it is necessary to increase the ring gear backlash by more than 0.2 mm, reduce the thrust washer thickness by 0.2 mm for every 0.2 mm increase of ring gear shim thickness.
- c. If it is necessary to reduce the ring gear backlash by more than 0.2 mm, increase the thrust washer thickness by 0.2 mm for every 0.2 mm decrease of ring gear shim thickness.

	Ring gear shims
Thickness (mm)	0.25 0.30 0.40 0.50
	Thrust washers
Thickness (mm)	1.2 1.4 1.6 1.8 2.0

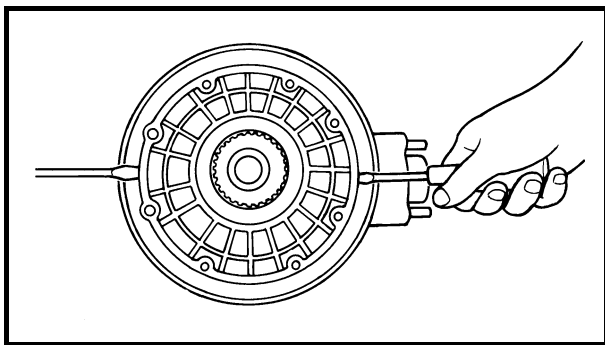

EAS00721

MEASURING THE RING-GEAR-TO-STOPPER-BOLT CLEARANCE

- Remove:
 - ring gear bearing housing (along with the ring gear)
 Refer to "ADJUSTING THE RING GEAR BACKLASH".

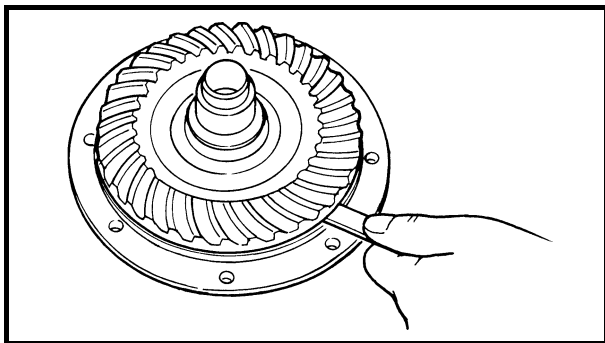

- Measure:
 - ring-gear-to-stopper-bolt clearance ①
 Out of specification → Adjust.



Ring-gear-to-stopper-bolt clearance
0.30 ~ 0.60 mm

- ① Stopper bolt
- ② Ring gear

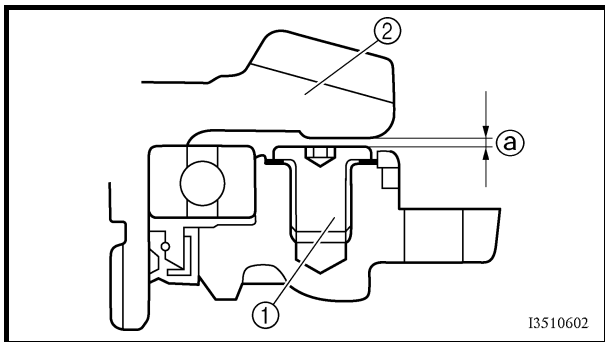

- Install:
 - ring gear bearing housing (along with the ring gear)

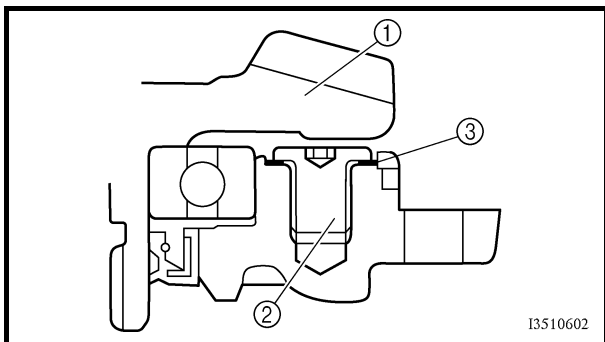

EAS00722

ADJUSTING THE RING-GEAR-TO-STOPPER-BOLT CLEARANCE

- Remove:
 - ring gear ①
 - stopper bolt ②
 - stopper bolt shim(s) ③
 - ring gear bearing housing
- Select:
 - stopper bolt shim(s)



Stopper bolt shims

Thickness (mm)	0.10	0.15	0.20	0.30	0.40	0.50
-----------------------	------	------	------	------	------	------

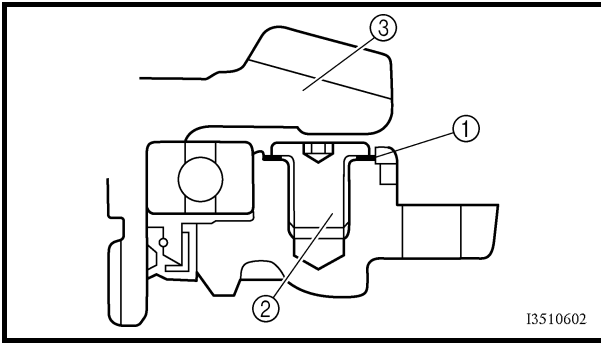

3. Install:

- stopper bolt shim(s) ①
- stopper bolt ②

 9 Nm (0.9 m · kg)
--
- ring gear ③
- ring gear bearing housing

CAUTION: _____

- **The stopper bolt has left-hand threads. To tighten the stopper bolt, turn it counter-clockwise.**
- **Apply LOCTITE® onto the stopper bolt.**

4. Measure:

- ring-gear-to-stopper-bolt clearance

NOTE: _____

If the ring-gear-to-stopper-bolt clearance is out of specification, repeat the above procedure.

EAS00718

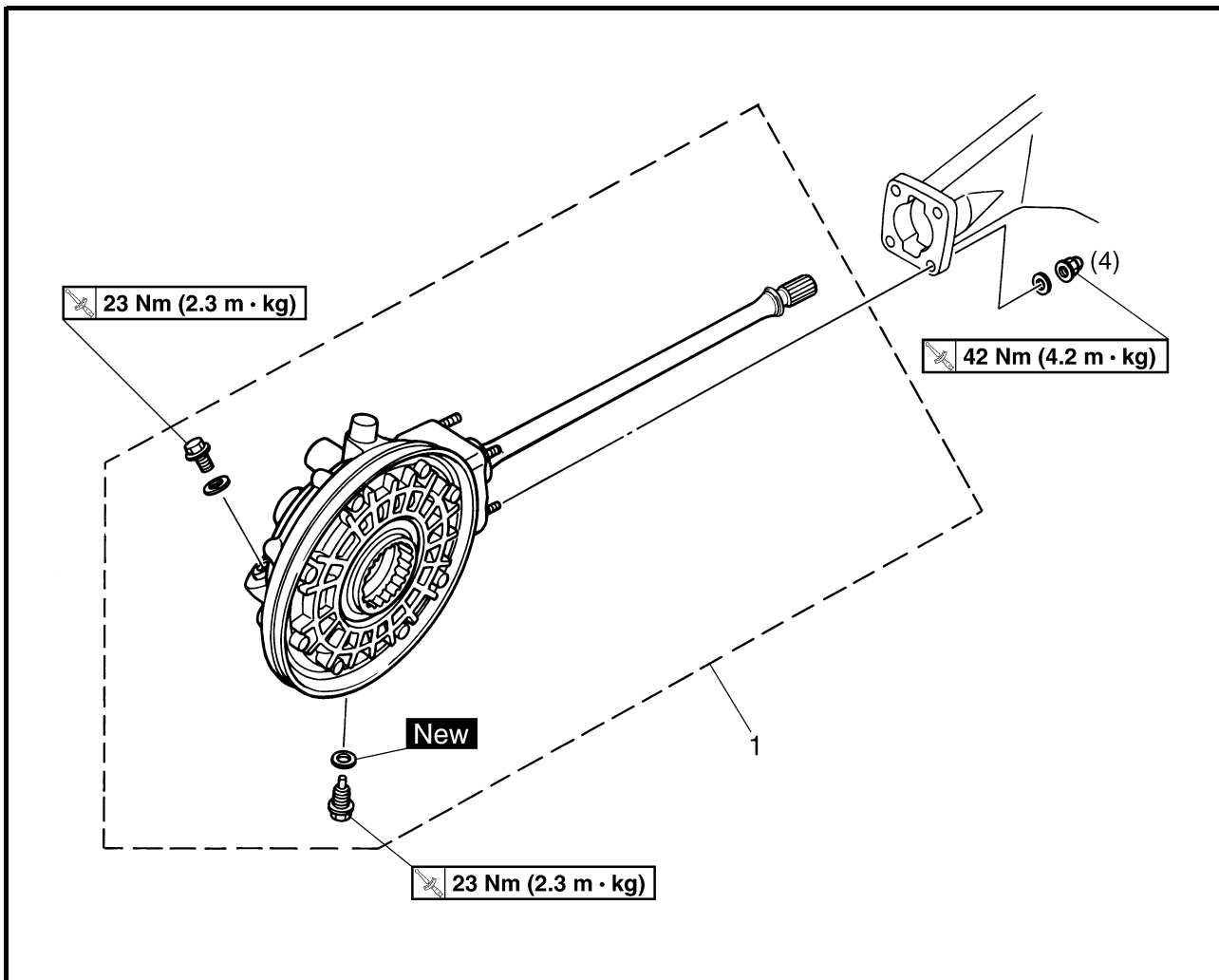

Order	Job/Part	Q'ty	Remarks
	Removing the final drive assembly		Remove the parts in the order listed.
	Final gear oil		Drain.
	Rear wheel		Refer to "REAR WHEEL AND BRAKE DISC".
1	Final drive assembly	1	Refer to "INSTALLING THE UNIVERSAL JOINT AND FINAL DRIVE ASSEMBLY". For installation, reverse the removal procedure.

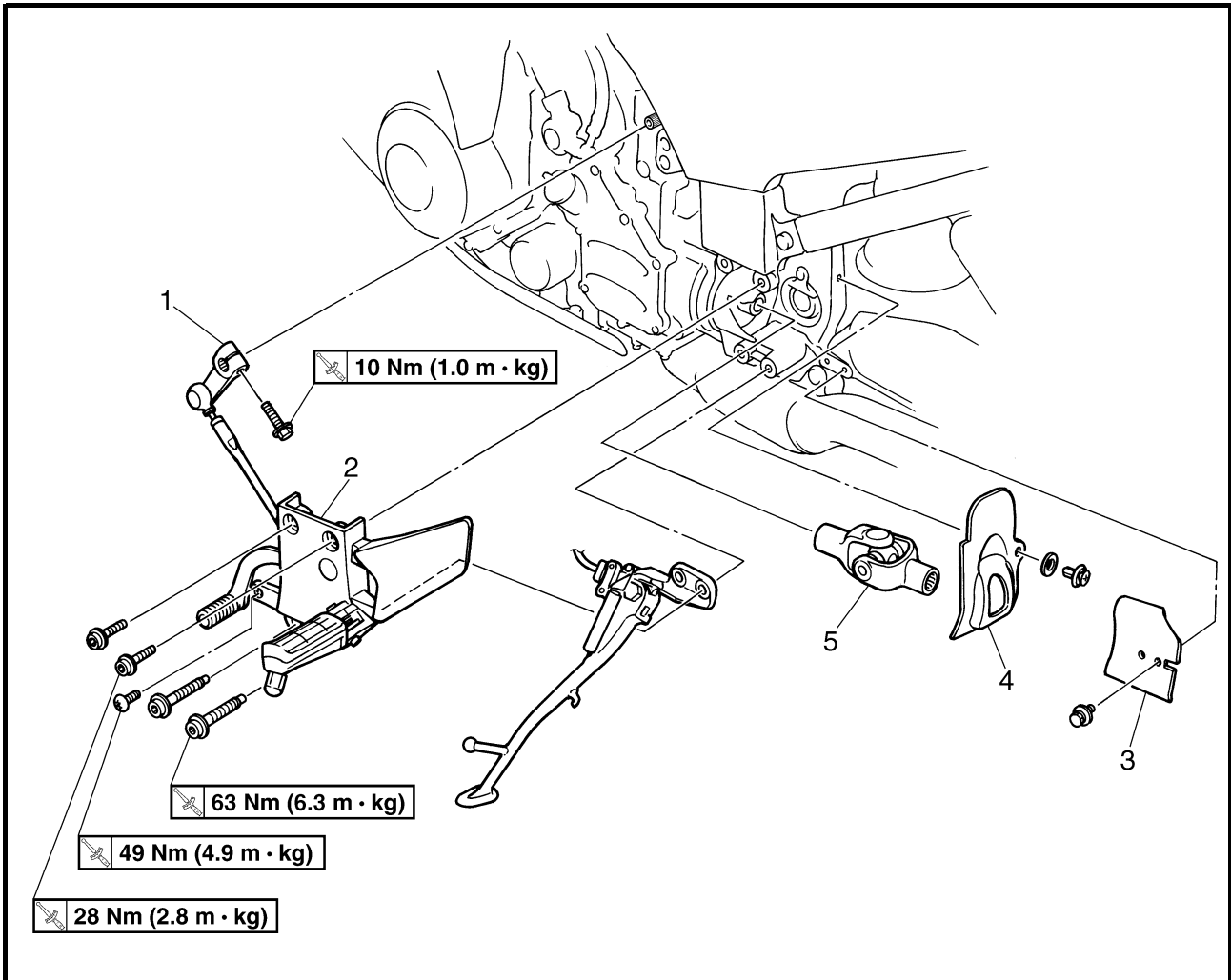

Order	Job/Part	Q'ty	Remarks
	Removing the universal joint		Remove the parts in the order listed.
	Final drive assembly		
1	Shift arm	1	Refer to "INSTALLING THE UNIVERSAL JOINT AND FINAL DRIVE ASSEMBLY".
2	Left footrest bracket	1	Refer to "REMOVING THE LEFT FOOTREST BRACKET".
3	Dust cover	1	
4	Dust seal	1	
5	Universal joint	1	
			For installation, reverse the removal procedure.

EAS00723

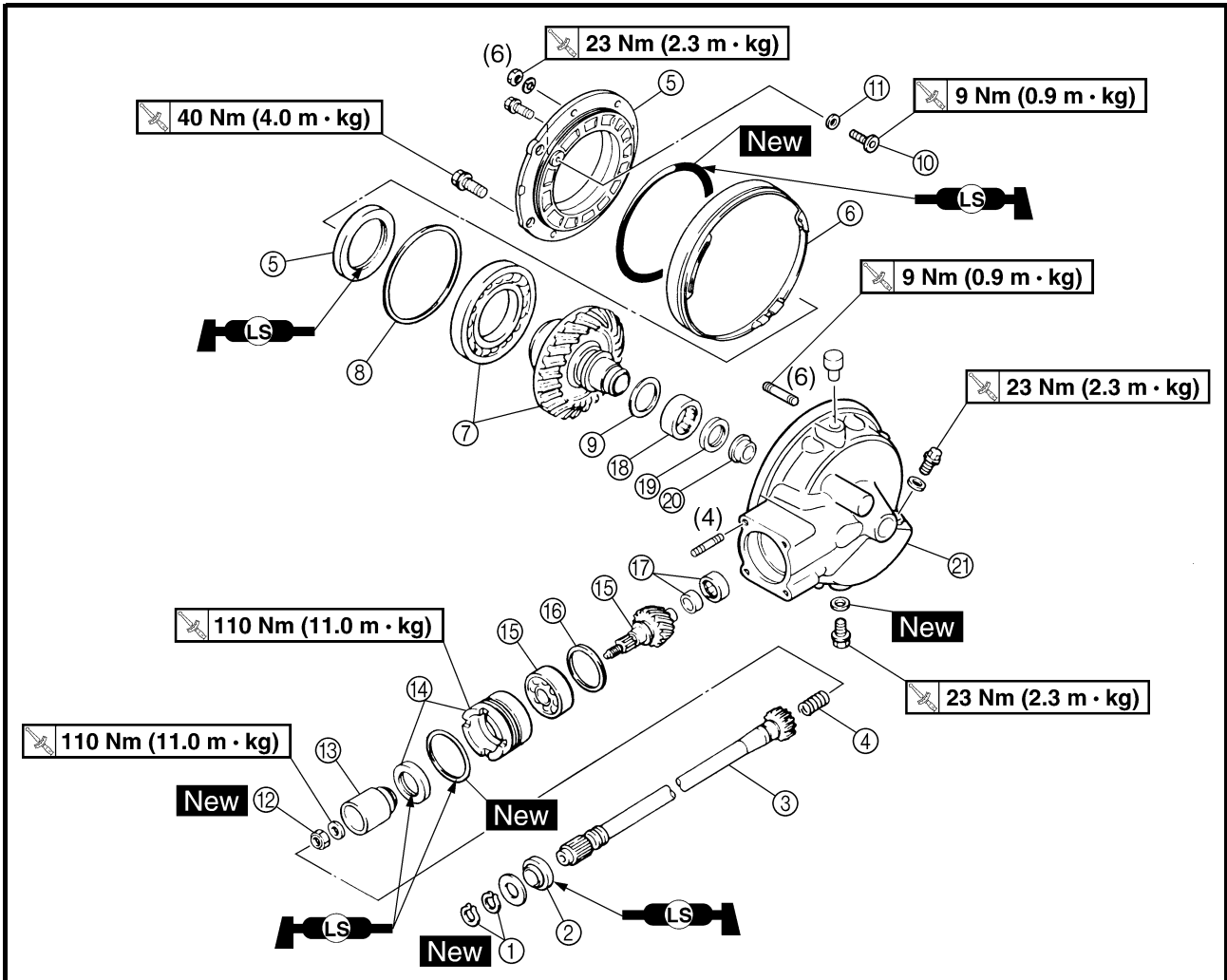

Order	Job/Part	Q'ty	Remarks
	Disassembling the final drive assembly		Remove the parts in the order listed.
①	Circlip	2	
②	Oil seal	1	
③	Drive shaft	1	
④	Spring	1	
⑤	Ring gear bearing housing/oil seal	1/1	
⑥	Dust cover	1	
⑦	Ring gear/bearing	1/1	Refer to "ALIGNING THE FINAL DRIVE PINION GEAR AND RING GEAR".
⑧	Ring gear shim(s)		
⑨	Thrust washer	1	
⑩	Stopper bolt	1	Left-hand threads.
⑪	Stopper bolt shim(s)		

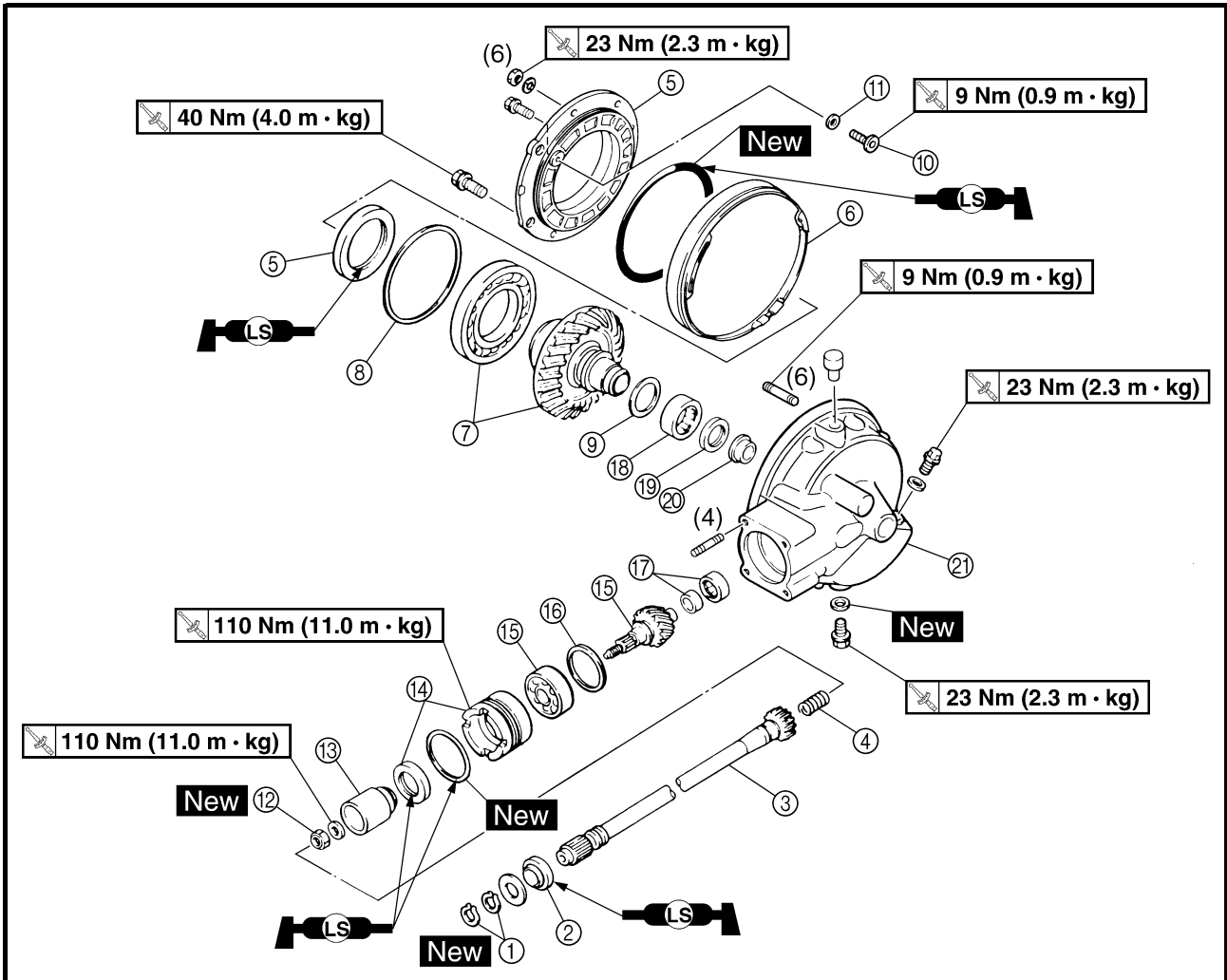

Order	Job/Part	Q'ty	Remarks
⑫	Nut	1	Left-hand threads. Refer to "DISASSEMBLING THE FINAL DRIVE ASSEMBLY" and "ALIGNING THE FINAL DRIVE PINION GEAR AND RING GEAR".
⑬	Gear coupling	1	
⑭	Bearing retainer/oil seal	1/1	
⑮	Final drive pinion gear/bearing	1/1	
⑯	Final drive pinion gear shim(s)		
⑰	Bearing	1	
⑱	Bearing	1	
⑳	Oil seal	1	
㉑	Collar	1	
㉒	Final drive housing	1	
			For assembly, reverse the disassembly procedure.

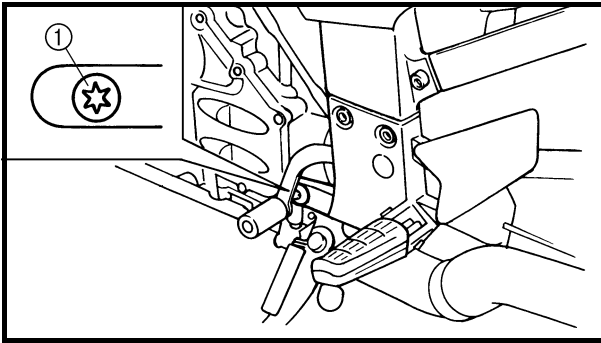

REMOVING THE LEFT FOOTREST BRACKET

1. Remove:
 - left footrest bracket bolt ① (with the T50 torx wrench)

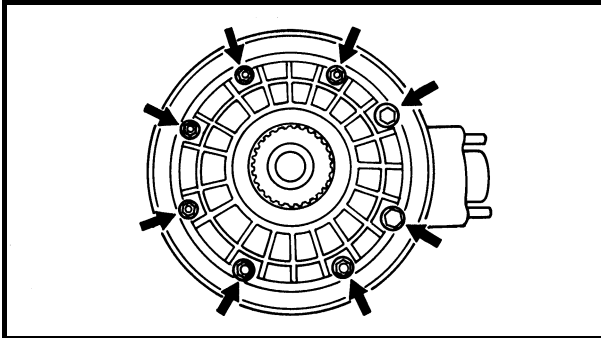

EAS00724

DISASSEMBLING THE FINAL DRIVE ASSEMBLY

1. Remove:
 - ring gear bearing housing nuts
 - ring gear bearing housing bolts

NOTE:

Working in a crisscross pattern, loosen each nut 1/4 of a turn. After all of the nuts are fully loosened, remove them and the bolts.

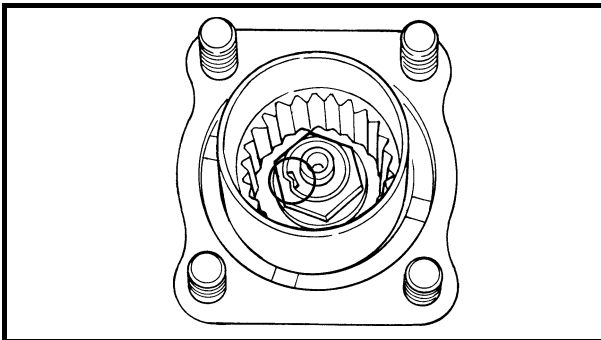

2. Straighten:
 - punched portion of the nut

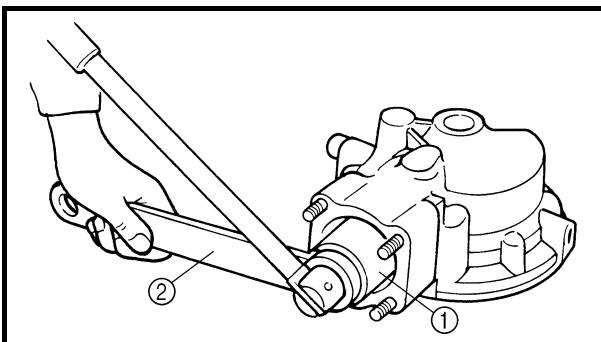

3. Remove:
 - nut
 - gear coupling ① (with the coupling gear/middle shaft tool ②)



Coupling gear/middle shaft tool
90890-01229

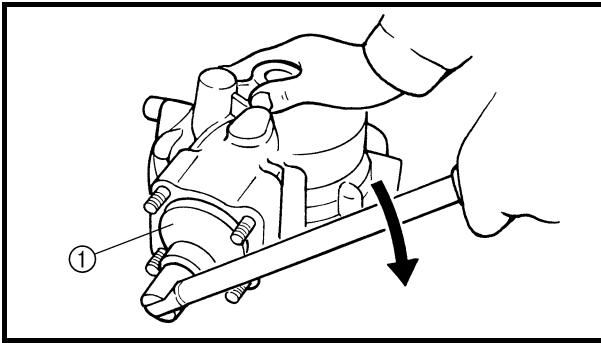

4. Remove:
 - bearing retainer
(with the bearing retainer wrench ①)



Bearing retainer wrench
90890-04050

CAUTION: _____

The bearing retainer has left-hand threads. To loosen the bearing retainer, turn it clockwise.

5. Remove:
 - final drive pinion gear

⚠ WARNING _____

Always use new bearings.

CAUTION: _____

The final drive pinion gear should only be removed if ring gear replacement is necessary.

NOTE: _____

Lightly tap on the end of the final drive pinion gear with a soft hammer.

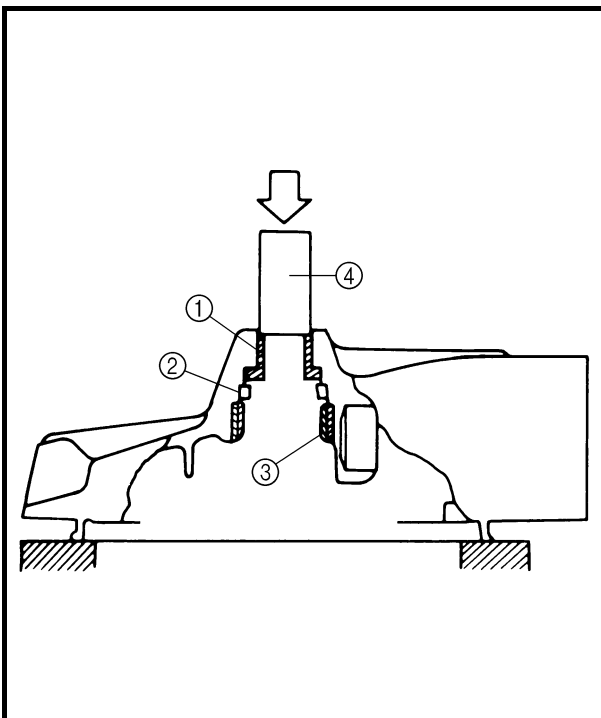

EAS00725

REMOVING AND INSTALLING THE RING GEAR BEARINGS

1. Remove:
 - collar ①
 - oil seal ②
 - bearing ③
(with an suitable press tool ④ and an appropriate support for the final drive housing)
2. Check:
 - bearing
Damage → Replace.

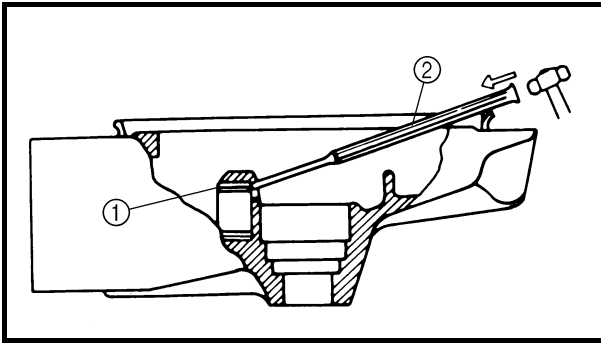

3. Remove:
- bearing ①



- Heat the final drive housing to approximately 150 °C.
- Remove the bearing outer races with an appropriately shaped punch ②.
- Remove the inner race from the final drive pinion gear.

NOTE: _____
 The removal of the final drive pinion gear bearing is a difficult procedure and is rarely necessary.



4. Install:
- bearing **New**



- Heat the final gear case to approximately 150 °C.
- Install the bearing outer races with a socket or appropriate tool that matches the diameter of the races.
- Install the inner race onto the final drive pinion gear.

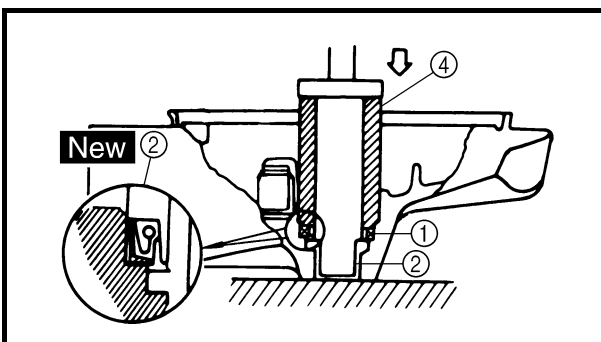

5. Install:
- collar ①
 - oil seal ② **New**
 - bearing ③
 (with a suitable press tool ④ and an appropriate support for the final drive housing)

NOTE: _____
 The bearing can be reused, but Yamaha recommends installing a new one.

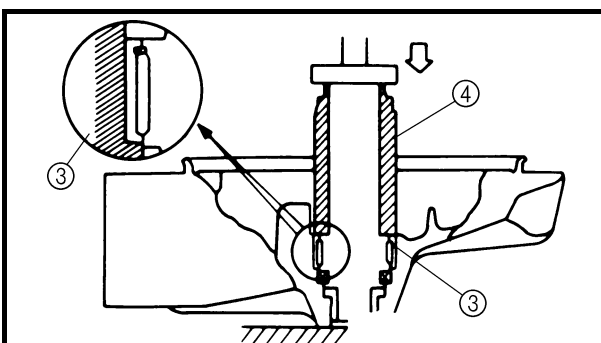

EAS00726

ALIGNING THE FINAL DRIVE PINION GEAR AND RING GEAR**NOTE:**

Aligning the final drive pinion gear and ring gear is necessary when any of the following parts are replaced:

- Final drive housing
- Ring gear bearing housing
- Any bearing

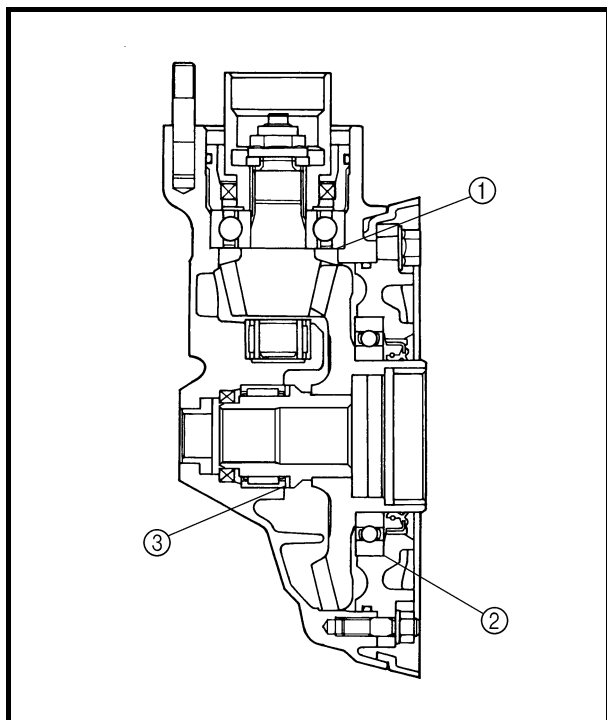

1. Select:

- final drive pinion gear shim(s) ①
- ring gear shim(s) ②

a. Position the final drive pinion gear and the ring gear with shims ① and ②. Calculate the respective thicknesses from information marked on the final drive housing and the drive pinion gear.

- ① Final drive pinion gear shim
- ② Ring gear shim
- ③ Thrust washer

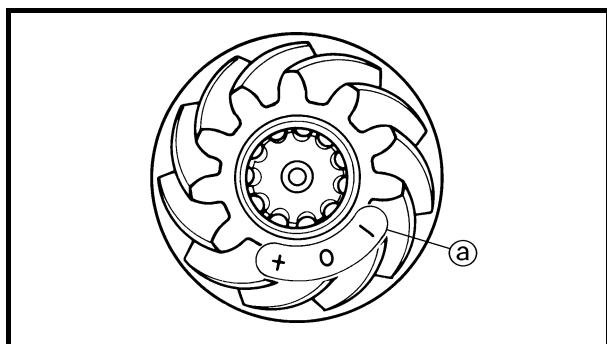

b. To find final drive pinion gear shim thickness "A", use the following formula:

$$\text{Final drive pinion gear shim thickness } A = (84 + \text{a}/100) - (83 + \text{b}/100)$$

Where:

Ⓐ = a numeral (positive or negative) on the final drive pinion gear, to be divided by 100 and added to "84". If there is not a numeral available on the final drive pinion gear, Ⓐ equals zero.

Ⓑ = a numeral on the final drive housing, to be divided by 100 and added to "83".

Example:

If the final drive pinion gear is marked "+01" and the final drive housing is marked "50":

$$\begin{aligned} A &= (84 + 1/100) - (83 + 50/100) \\ &= (84 + 0.01) - (83 + 0.50) \\ &= 84.01 - 83.50 \\ &= 0.51 \end{aligned}$$

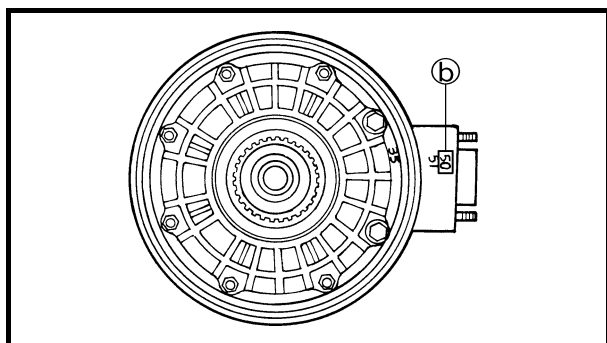

Therefore, the calculated final drive pinion gear shim thickness is 0.51 mm. Shim sizes are supplied in the following thicknesses.

	Final drive pinion gear shims
Thickness (mm)	0.30 0.40 0.50

Since the final drive pinion gear shims are only available in 0.10 mm increments, round off to the hundredths digit.

Hundredth	Rounded value
0, 1, 2	0
3, 4, 5, 6, 7	5
8, 9	10

In the example above, the calculated final drive pinion gear shim thickness is 0.51 mm. The chart instructs you to round off the 1 to 0. Thus, you should use a 0.50 mm final drive pinion gear shim.

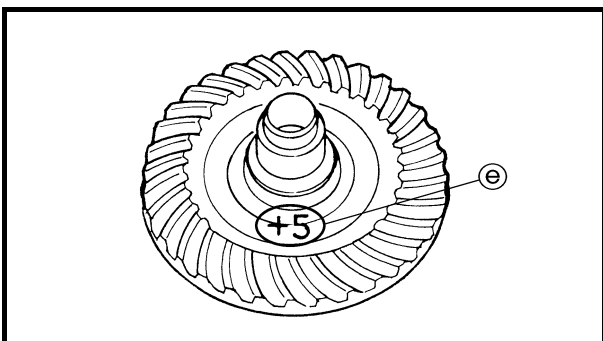
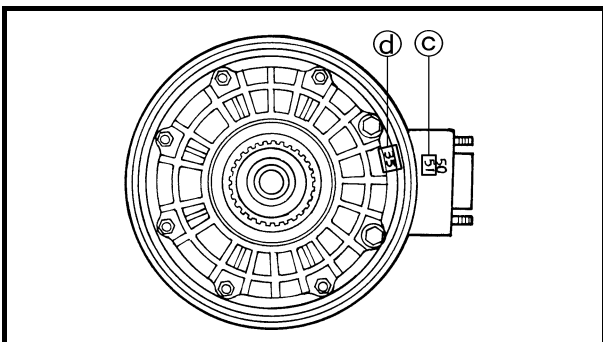

c. To find ring gear shim thickness “B”, use the following formula:

<p>Ring gear shim thickness $B = (45 + \text{c}/100) + (3 + \text{d}/100) - [(35.40 - \text{e}/100) + \text{f}]$</p>

Where:

© = a numeral on the final drive housing, to be divided by 100 and added to “45”.

ⓓ = a numeral usually on the outside of the ring gear bearing housing, to be divided by 100 and added to “3”.

ⓔ = a numeral (positive or negative) on the inside of the ring gear, to be divided by 100 and added to “35.40”.

ⓕ = the ring gear bearing thickness constant.

	Ring gear bearing thickness “f” 13.00 mm
---	--

Example:

If the final drive housing is marked “51”, the ring gear bearing housing is marked “35”, the ring gear is marked “- 05”, and “f” is 13.00:

$$\begin{aligned}
 B &= (45 + 51/100) + (3 + 35/100) - \\
 &\quad [(35.40 - 5/100) + 13] \\
 &= (45 + 0.51) + (3 + 0.35) - \\
 &\quad [(35.40 - 0.05) + 13] \\
 &= 45.51 + 3.35 - [(35.40 - 0.05) + 13] \\
 &= 48.86 - [35.35 + 13] \\
 &= 48.86 - 48.35 \\
 &= 0.51
 \end{aligned}$$

Therefore, the calculated ring gear shim thickness is 0.51 mm.

Shim sizes are supplied in the following thicknesses.

	Ring gear shims
Thickness (mm)	0.25 0.30 0.40 0.50

Since the ring gear shims are only available in 0.10 mm increments, round off the hundredths digit.

Hundredth	Rounded value
0, 1, 2	0
3, 4, 5, 6, 7	5
8, 9	10

In the example above, the calculated ring gear shim thickness is 0.51 mm. The chart instructs you to round off the 1 to 0. Thus, you should use a 0.50 mm ring gear shim.



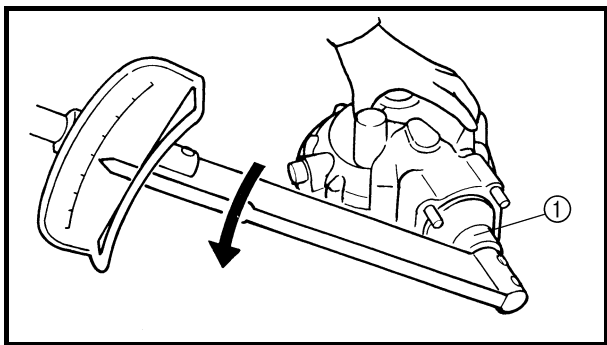

2. Install:

- shims (as calculated)
- final drive pinion gear
- bearing retainer  **110 Nm (11.0 m · kg)**
(with the bearing retainer wrench ①)

CAUTION:

The bearing retainer has left-hand threads. To tighten the bearing retainer, turn it counterclockwise.



Bearing retainer wrench
90890-04050

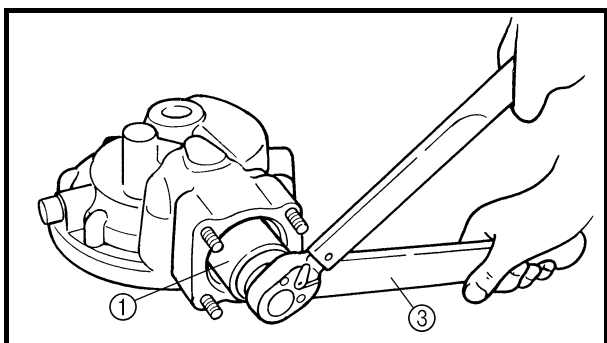

3. Install:

- gear coupling ①
- nut ②  **110 Nm (11.0 m · kg)**
(with the coupling gear/middle shaft tool ③)



Coupling gear/middle shaft tool
90890-01229

CAUTION:

Apply **LOCTITE®** to the nut.

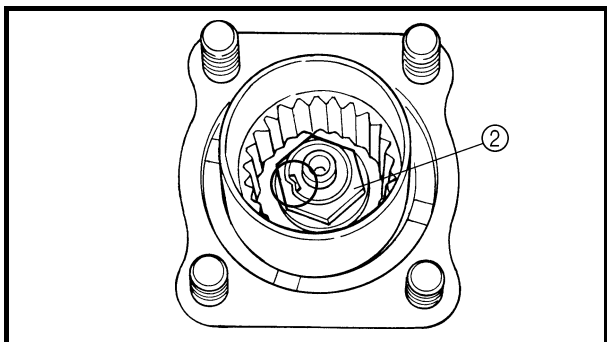

4. Lock the threads with a drift punch.

5. Install:

- ring gear bearing housing
(along with the ring gear, but without the thrust washer)

6. Adjust:

- ring gear backlash
Refer to “MEASURING THE RING GEAR BACKLASH” and “ADJUSTING THE RING GEAR BACKLASH”.

7. Measure:

- ring-gear-to-thrust-washer clearance



- Remove the ring gear bearing housing (along with the ring gear).
- Place four pieces of Plastigauge® between the original thrust washer and the ring gear.
- Install the ring gear bearing housing and tighten the bolts and nuts to specification.

	Ring gear bearing housing bolt 40 Nm (4.0 m · kg)
	Ring gear bearing housing nut 23 Nm (2.3 m · kg)

NOTE:

Do not turn the final drive pinion gear and ring gear while measuring the ring-gear-to-thrust-washer clearance with Plastigauge®.

- Remove the ring gear bearing housing.
- Measure the width of the flattened Plastigauge® ①.

	Ring-gear-to-thrust-washer clearance 0.10 ~ 0.20 mm
---	---

- If the ring-gear-to-thrust-washer clearance is within specification, install the ring gear bearing housing (along with the ring gear).
- If the ring-gear-to-thrust-washer clearance is out of specification, select the correct thrust washer as follows.
- Select the suitable thrust washer from the following chart.

	Thrust washers				
	Thickness (mm)	1.2	1.4	1.6	1.8

- Repeat the measurement steps until the ring-gear-to-thrust-washer clearance is within the specified limits.

	Ring-gear-to-thrust-washer clearance 0.10 ~ 0.20 mm
---	---

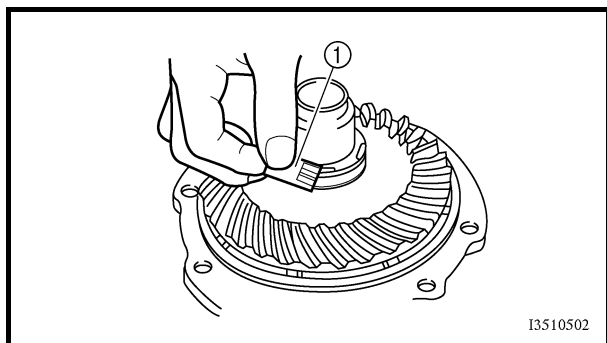

I3510502

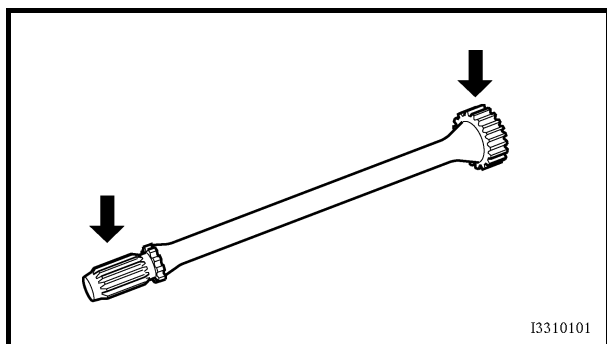

EAS00727

CHECKING THE DRIVE SHAFT

1. Check:
 - drive shaft splines
 Damage/wear → Replace the drive shaft.

EAS00728

INSTALLING THE UNIVERSAL JOINT AND FINAL DRIVE ASSEMBLY

1. Lubricate:
 - universal joint splines
 - drive shaft splines



Recommended lubricant
Lithium soap base grease

2. Install:
 - universal joint
 - final drive assembly

NOTE:

Align the drive shaft splines with the driven yoke of the universal joint.

3. Tighten:
 - final drive assembly nuts

 **42 Nm (4.2 m · kg)**

4. Install:
 - shift arm ①

 **10 Nm (1.0 m · kg)**

NOTE:

Align the punch mark ② in the shift shaft with the slot in the shift arm.

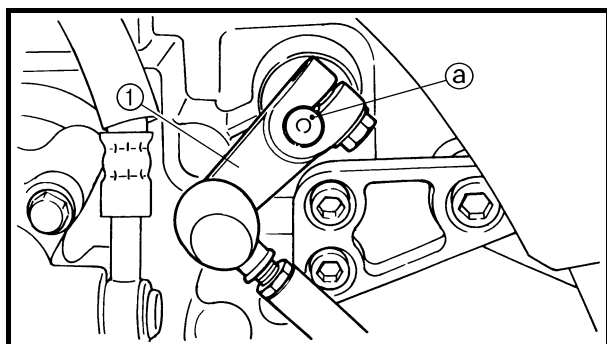

5. Install:
 - rear wheel
 Refer to “REAR WHEEL AND BRAKE DISC”.
6. Fill:
 - final drive assembly
 Refer to “CHECKING THE FINAL DRIVE OIL LEVEL” in chapter 3.
7. Check:
 - shift pedal position
 Refer to “ADJUSTING THE SHIFT PEDAL” in chapter 3.

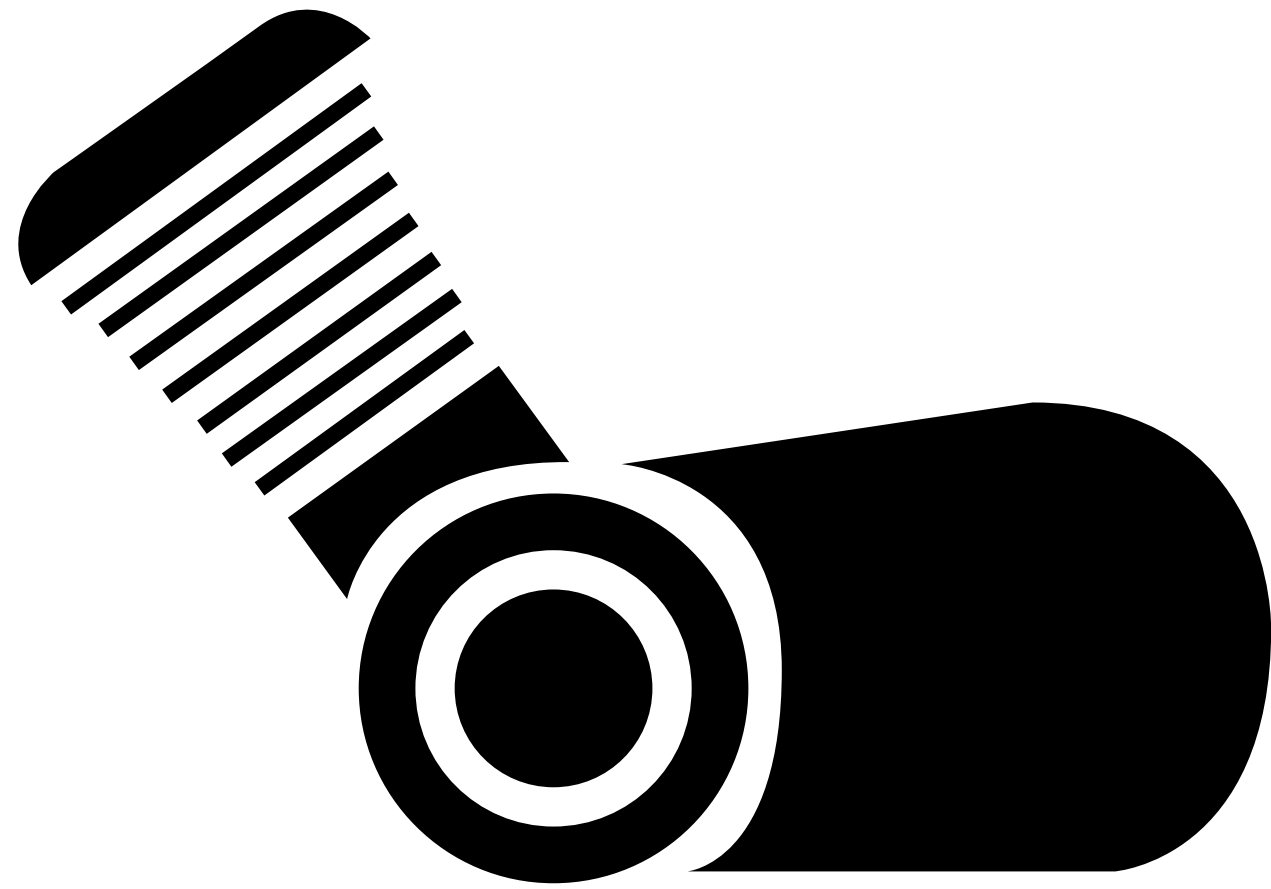

ENG

5

CHAPTER 5 ENGINE

ENGINE	5-1
MUFFLERS AND EXHAUST PIPE ASSEMBLY	5-1
LEADS AND HOSES.....	5-2
ENGINE.....	5-4
INSTALLING THE ENGINE.....	5-6
CAMSHAFTS	5-8
CYLINDER HEAD COVER.....	5-8
CAMSHAFTS	5-9
REMOVING THE CAMSHAFTS.....	5-11
CHECKING THE CAMSHAFTS	5-12
CHECKING THE CAMSHAFT SPROCKETS	5-13
CHECKING THE TIMING CHAIN TENSIONER.....	5-14
INSTALLING THE CAMSHAFTS	5-14
CYLINDER HEAD	5-19
REMOVING THE CYLINDER HEAD.....	5-20
CHECKING THE CYLINDER HEAD	5-20
INSTALLING THE CYLINDER HEAD	5-21
VALVES AND VALVE SPRINGS	5-24
REMOVING THE VALVES.....	5-25
CHECKING THE VALVES AND VALVE GUIDES	5-26
CHECKING THE VALVE SEATS.....	5-28
CHECKING THE VALVE SPRINGS.....	5-30
CHECKING THE VALVE LIFTERS	5-31
INSTALLING THE VALVES	5-32
GENERATOR AND STARTER CLUTCH	5-34
GENERATOR ROTOR AND STARTER CLUTCH.....	5-34
STATOR ASSEMBLY.....	5-36
REMOVING THE GENERATOR.....	5-37
REMOVING THE STARTER CLUTCH	5-38
CHECKING THE STARTER CLUTCH	5-38
INSTALLING THE STARTER CLUTCH.....	5-39
INSTALLING THE GENERATOR.....	5-39
PICKUP COIL ROTOR	5-41
REMOVING THE PICKUP COIL ROTOR	5-43
INSTALLING THE PICKUP COIL ROTOR.....	5-43



CLUTCH	5-45
CLUTCH COVER	5-45
CLUTCH	5-46
REMOVING THE CLUTCH	5-48
CHECKING THE FRICTION PLATES	5-49
CHECKING THE CLUTCH PLATES	5-50
CHECKING THE CLUTCH SPRING PLATE	5-50
CHECKING THE CLUTCH HOUSING	5-50
CHECKING THE CLUTCH BOSS	5-51
CHECKING THE PRESSURE PLATE	5-51
CHECKING THE CLUTCH PUSH RODS	5-51
CHECKING THE PRIMARY DRIVEN GEAR	5-51
INSTALLING THE CLUTCH	5-52
SHIFT SHAFT	5-55
CHECKING THE SHIFT SHAFT	5-57
CHECKING THE STOPPER LEVER	5-57
INSTALLING THE SHIFT SHAFT	5-57
OIL PAN AND OIL PUMP	5-59
OIL PUMP	5-61
REMOVING THE OIL PAN	5-62
CHECKING THE OIL PUMP	5-62
CHECKING THE RELIEF VALVE	5-63
CHECKING THE OIL DELIVERY PIPES	5-63
CHECKING THE OIL STRAINER	5-63
ASSEMBLING THE OIL PUMP	5-63
INSTALLING THE OIL PUMP	5-64
INSTALLING THE OIL STRAINER	5-64
INSTALLING THE OIL PAN	5-64
MIDDLE GEAR	5-66
REMOVING THE MIDDLE GEAR	5-70
DISASSEMBLING THE MIDDLE DRIVE SHAFT ASSEMBLY	5-71
DISASSEMBLING THE MIDDLE DRIVEN SHAFT ASSEMBLY	5-71
CHECKING THE MIDDLE DRIVE SHAFT ASSEMBLY	5-71
CHECKING THE MIDDLE DRIVEN SHAFT ASSEMBLY	5-72
ASSEMBLING THE MIDDLE DRIVE SHAFT ASSEMBLY	5-72
ASSEMBLING THE MIDDLE DRIVEN SHAFT ASSEMBLY	5-72
INSTALLING THE MIDDLE DRIVE SHAFT ASSEMBLY	5-73
INSTALLING THE MIDDLE DRIVEN SHAFT ASSEMBLY	5-74
MEASURING THE MIDDLE GEAR BACKLASH	5-75
ADJUSTING THE MIDDLE GEAR BACKLASH	5-76
ALIGNING THE MIDDLE GEAR	5-79
CRANKCASE	5-82
DISASSEMBLING THE CRANKCASE	5-86
CHECKING THE CRANKCASE	5-87
CHECKING THE BEARINGS AND OIL SEALS	5-87
CHECKING THE TIMING CHAIN AND OIL PUMP DRIVE CHAIN	5-88
ASSEMBLING THE CRANKCASE	5-88

CONNECTING RODS AND PISTONS	5-92
REMOVING THE CONNECTING RODS AND PISTONS	5-93
CHECKING THE CYLINDERS AND PISTONS	5-94
CHECKING THE PISTON RINGS.....	5-95
CHECKING THE PISTON PINS.....	5-96
CHECKING THE CONNECTING RODS.....	5-98
INSTALLING THE CONNECTING RODS AND PISTONS	5-100
CRANKSHAFT	5-104
REMOVING THE CRANKSHAFT	5-105
CHECKING THE CRANKSHAFT	5-105
INSTALLING THE CRANKSHAFT	5-108
TRANSMISSION	5-109
REMOVING THE TRANSMISSION	5-115
CHECKING THE SHIFT FORKS.....	5-115
CHECKING THE SHIFT DRUM ASSEMBLY	5-116
CHECKING THE TRANSMISSION	5-116
INSTALLING THE TRANSMISSION	5-118
BALANCERS	5-119
FRONT BALANCER.....	5-119
REAR BALANCER	5-120
CHECKING THE BALANCER	5-121
INSTALLING THE FRONT BALANCER.....	5-121
INSTALLING THE REAR BALANCER	5-123



EAS00188

ENGINE

ENGINE

MUFFLERS AND EXHAUST PIPE ASSEMBLY

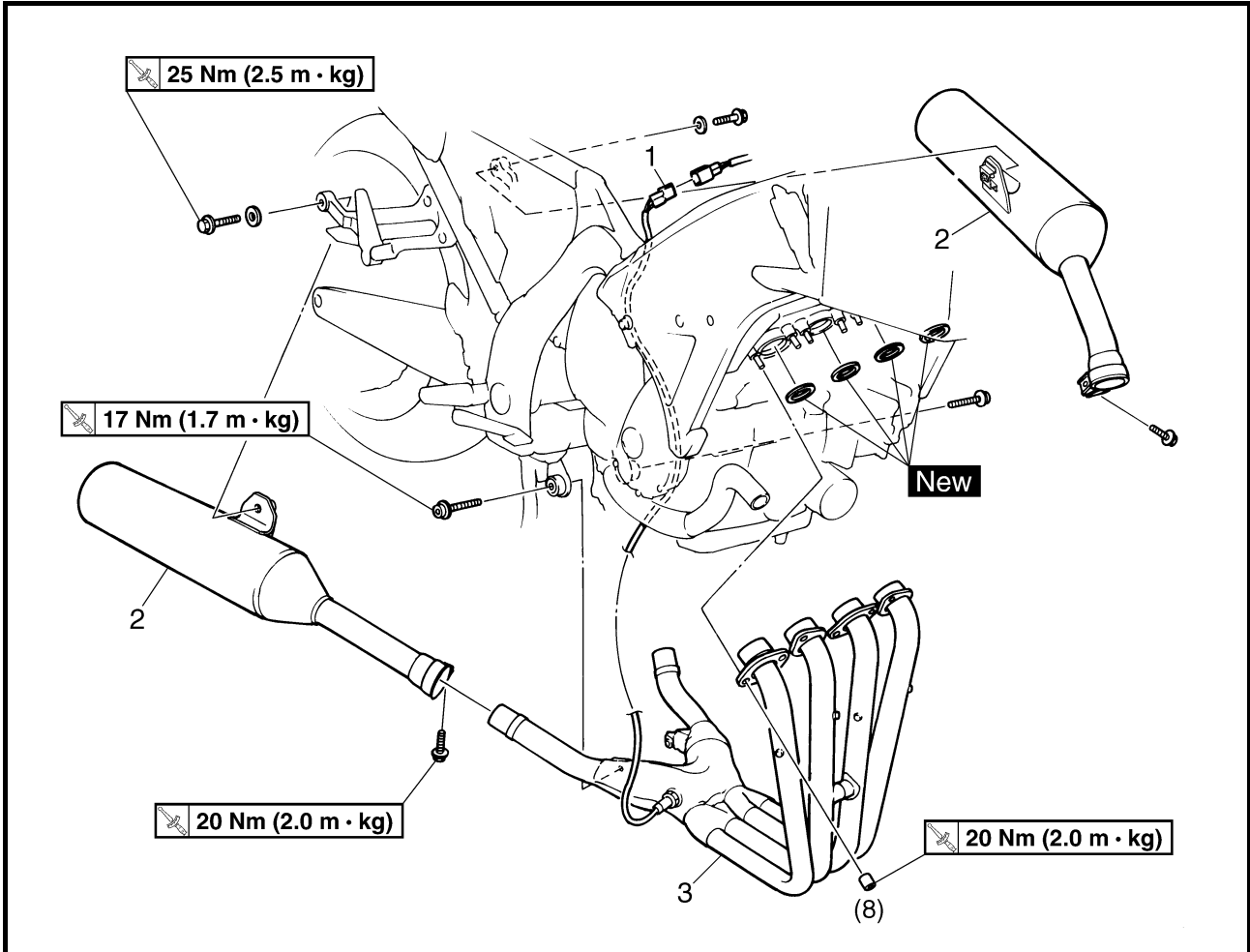

Order	Job/Part	Q'ty	Remarks
	Removing the mufflers and exhaust pipe assembly		Remove the parts in the order listed.
	Seats/fuel tank/T-bar/rubber seat		Refer to "SEATS AND FUEL TANK" in chapter 3.
	Side cowlings/front cowling assembly		Refer to "COWLINGS" in chapter 3.
	Coolant		Drain. Refer to "CHANGING THE COOLANT" in chapter 3.
	Radiator		Refer to "RADIATOR" in chapter 6.
1	O ₂ sensor coupler	1	Disconnect.
2	Muffler (left and right)	2	
3	Exhaust pipe assembly	1	
			For installation, reverse the removal procedure.



LEADS AND HOSES

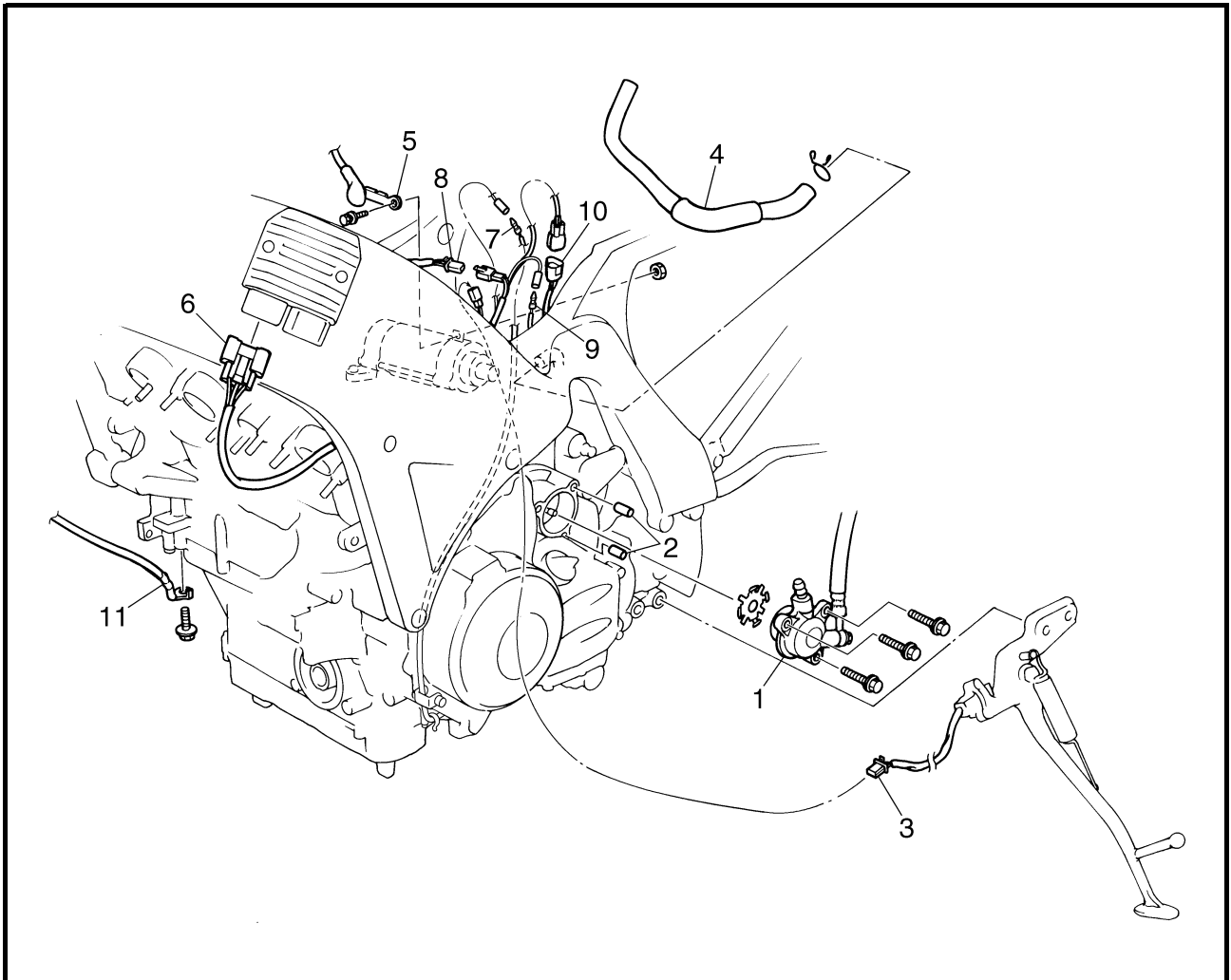

Order	Job/Part	Q'ty	Remarks
	Removing the leads and hoses		Remove the parts in the order listed.
	Air filter case		Refer to "AIR FILTER CASE" in chapter 3.
	Throttle bodies		Refer to "FUEL INJECTION SYSTEM" in chapter 7.
	Air cut-off valve assembly/hoses/reed valves		Refer to "AIR INDUCTION SYSTEM" in chapter 7.
	Thermostat assembly		Refer to "THERMOSTAT" in chapter 6.
	Engine oil/oil filter cartridge		Drain. Refer to "CHANGING THE ENGINE OIL" in chapter 3.
	Oil cooler		Refer to "OIL COOLER" in chapter 6.
	Water pump		Refer to "WATER PUMP" in chapter 6.

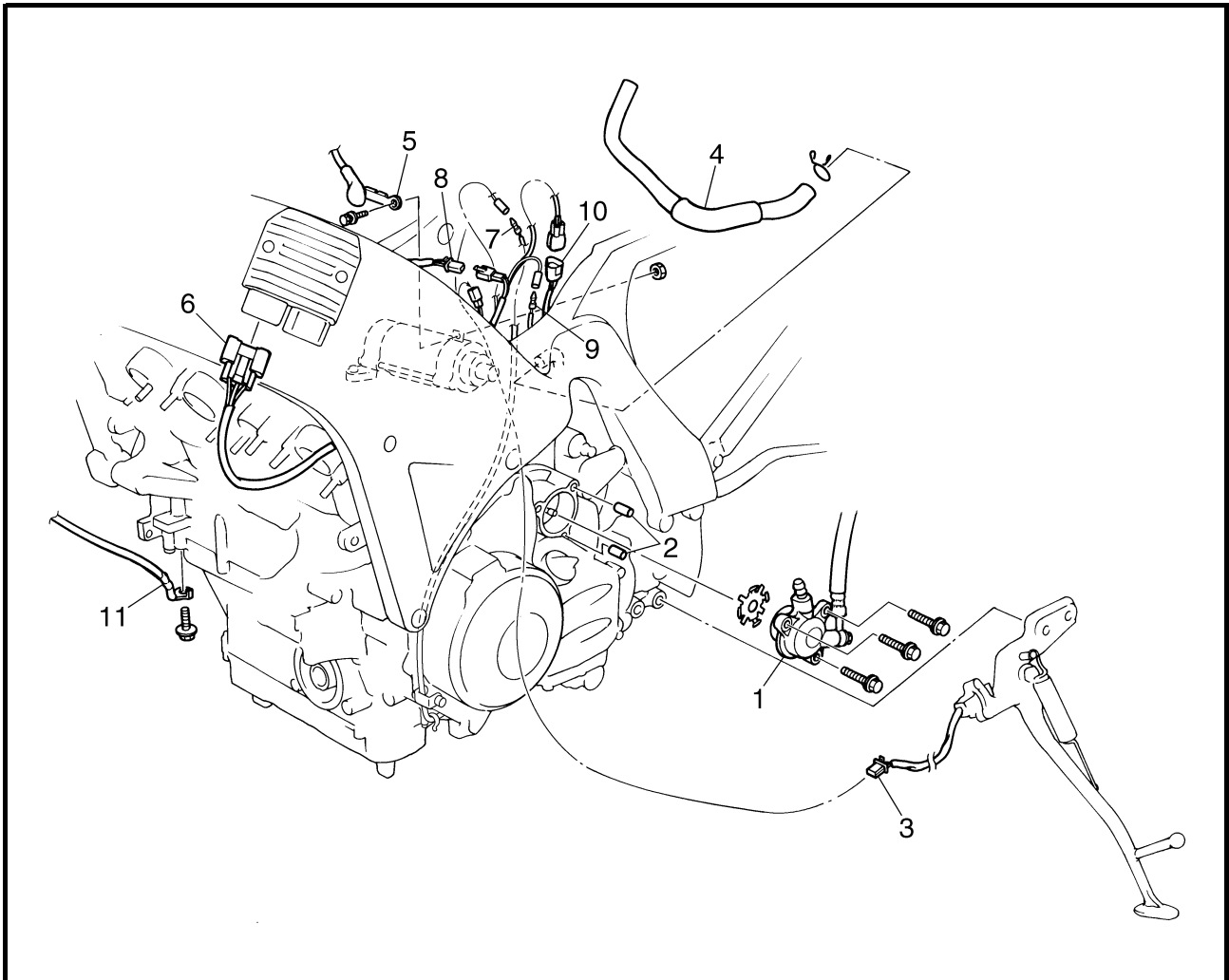

Order	Job/Part	Q'ty	Remarks
	Left footrest bracket/dust cover		Refer to "SHAFT DRIVE" in chapter 4.
1	Clutch release cylinder	1	
2	Dowel pin	2	
3	Sidestand switch coupler	1	Disconnect.
4	Crankcase breather hose	1	
5	Starter motor lead	1	Disconnect.
6	Stator assembly coupler	1	Disconnect.
7	Oil level sensor connector	1	Disconnect.
8	Crankshaft position sensor coupler	1	Disconnect.
9	Neutral switch connector	1	Disconnect.
10	Speed sensor coupler	1	Disconnect.
11	Ground lead	1	
			For installation, reverse the removal procedure.



EAS00191

ENGINE

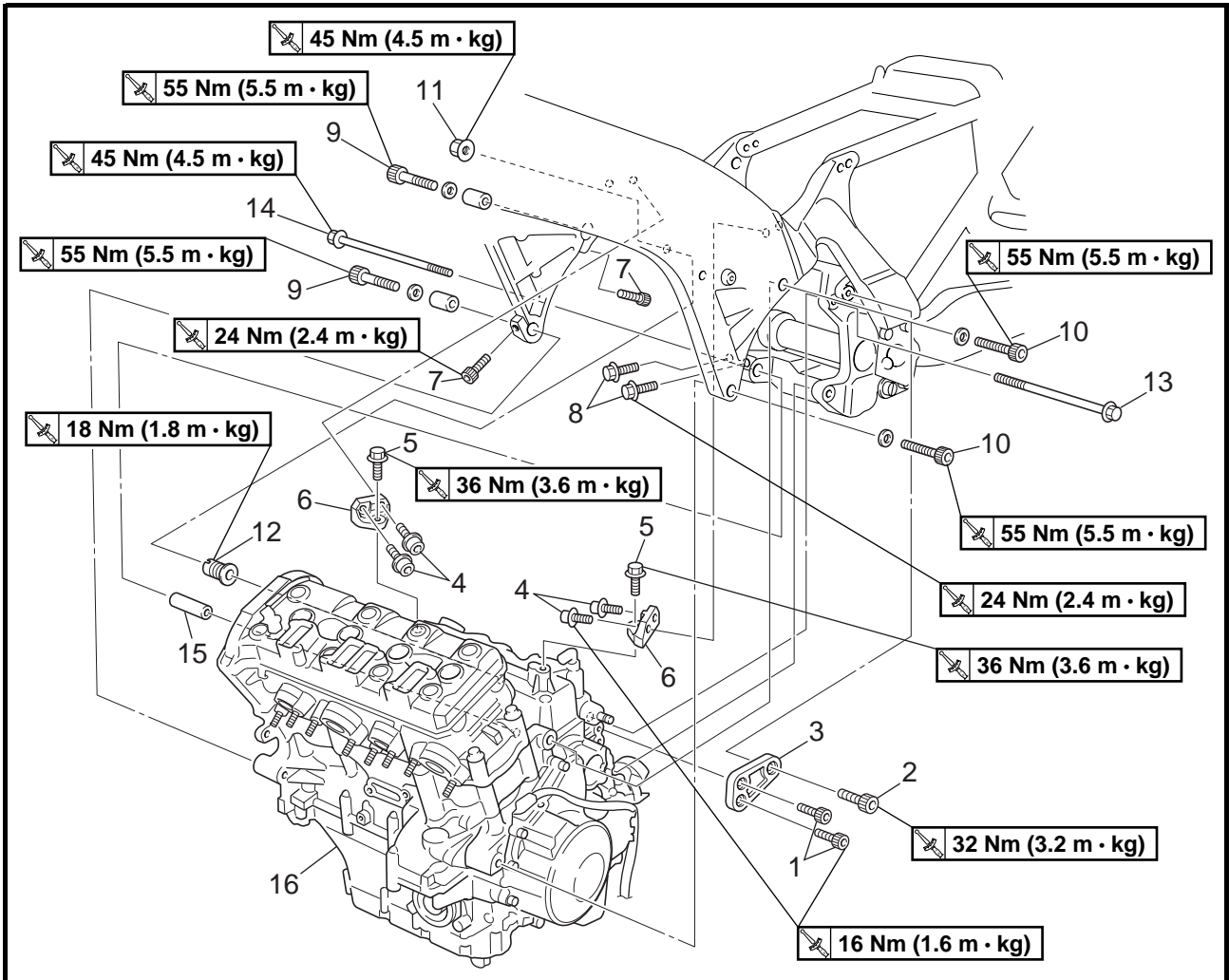

Order	Job/Part	Q'ty	Remarks
	Removing the engine		Remove the parts in the order listed.
			NOTE: _____ Place a suitable stand under the frame and engine.
1	Bolt (engine bracket 1 and engine)	2	Refer to "INSTALLING THE ENGINE".
2	Bolt (engine bracket 1 and frame)	1	
3	Engine bracket 1	1	
4	Bolt (engine bracket 2 and frame)	4	
5	Bolt (engine bracket 2 and engine)	2	
6	Engine bracket 2	2	
7	Pinch bolt	2	
8	Pinch bolt	2	
9	Front mounting bolt (right)	2	
10	Front mounting bolt (left)	2	

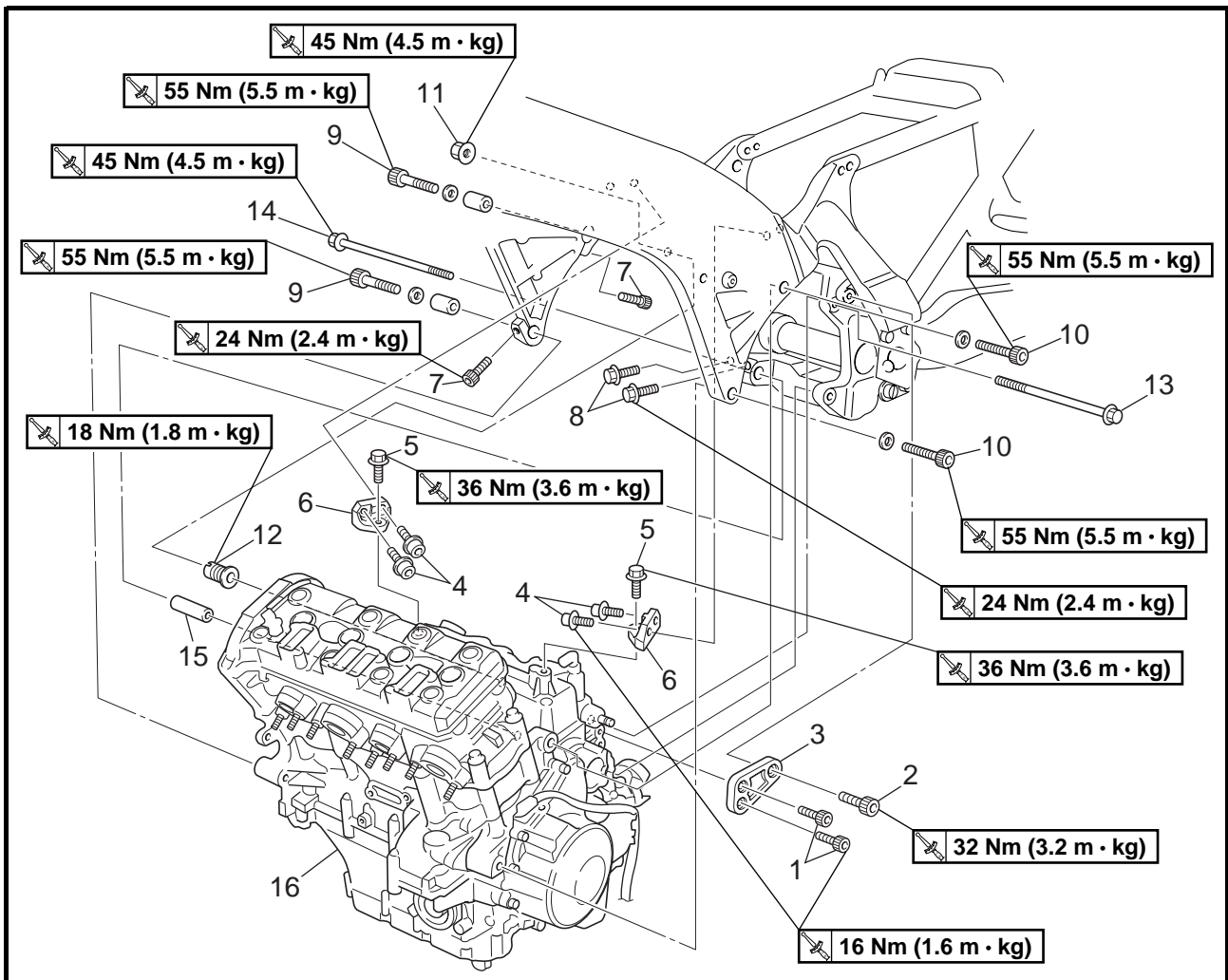

Order	Job/Part	Q'ty	Remarks
11	Nut	1	Loosen. Refer to "INSTALLING THE ENGINE".
12	Spacer bolt	1	
13	Rear upper mounting bolt	1	
14	Rear lower mounting bolt	1	
15	Spacer	1	
16	Engine	1	
			For installation, reverse the removal procedure.

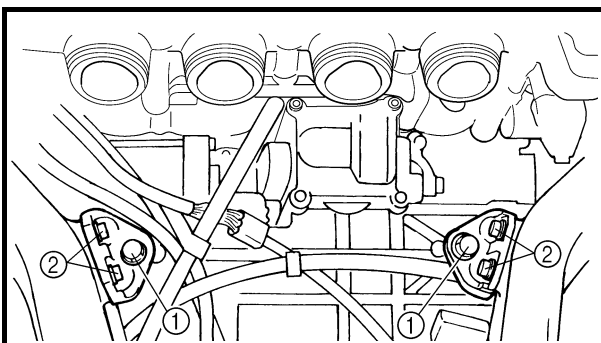
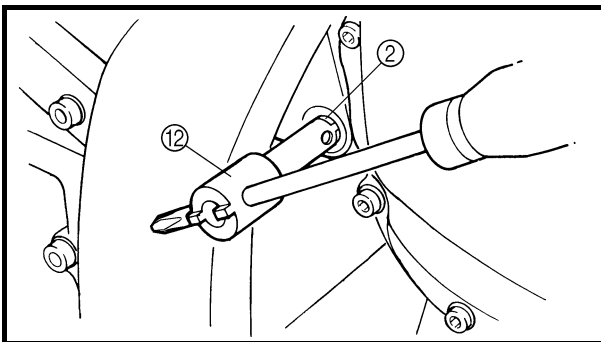
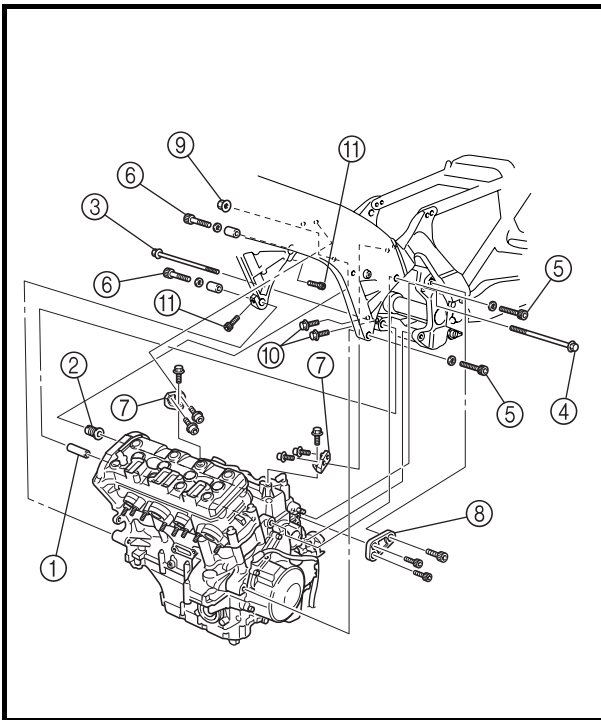

EAS00192

INSTALLING THE ENGINE

1. Install:

- spacer ①
- spacer bolt ②
- rear lower mounting bolt ③
- rear upper mounting bolt ④
- front mounting bolts ⑤, ⑥
- engine bracket 2 ⑦
- engine bracket 1 ⑧

NOTE:

Do not fully tighten the bolts.

2. Tighten the bolts in the following order.

- front mounting bolts (left) ⑤

	55 Nm (5.5 m · kg)
---	---------------------------

- rear lower mounting bolt ③

	45 Nm (4.5 m · kg)
---	---------------------------

- spacer bolt ②

	18 Nm (1.8 m · kg)
---	---------------------------

- nut ⑨

	45 Nm (4.5 m · kg)
---	---------------------------

- front mounting bolts (left) ⑤

	55 Nm (5.5 m · kg)
--	---------------------------

- front mounting bolts (right) ⑥

	55 Nm (5.5 m · kg)
---	---------------------------

- pinch bolts ⑩

	24 Nm (2.4 m · kg)
---	---------------------------

- pinch bolt ⑪

	24 Nm (2.4 m · kg)
---	---------------------------

NOTE:

- Tighten the spacer bolt ② to specification with a pivot shaft wrench ⑫.
- When tightened, the spacer bolt ② should be flat against the engine surface.



Pivot shaft wrench
90890-01471

- 3. Temporarily tighten the bolts (engine bracket 2 and engine) ① and bolts (engine bracket 2 and frame) ②.

NOTE:

When temporarily tightened, the bolts ①, ② should be flat against the engine and frame surface.

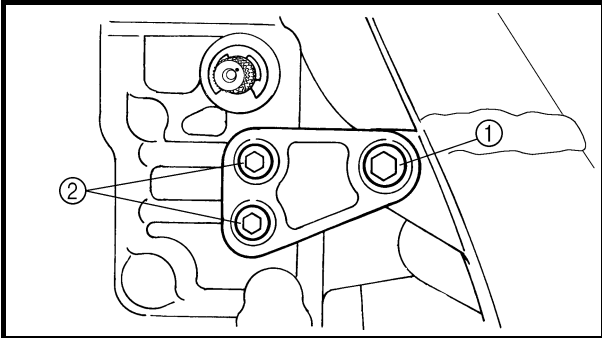
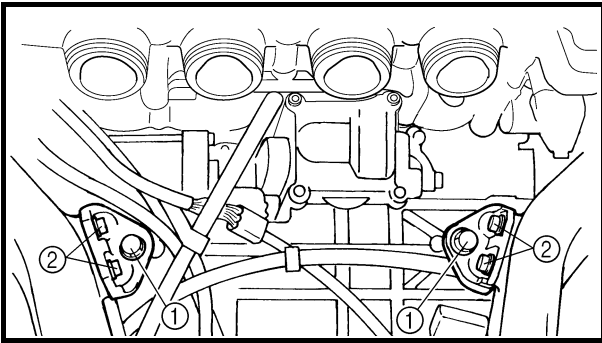

4. Tighten the bolts in the following order.

- bolts (engine bracket 2 and engine) ①

 **36 Nm (3.6 m · kg)**

- bolts (engine bracket 2 and frame) ②

 **16 Nm (1.6 m · kg)**

5. Temporarily tighten the bolt (engine bracket 1 and frame) ① and bolts (engine bracket 1 and engine) ②.

NOTE: _____

When temporarily tightened, the bolts ①, ② should be flat against the engine and frame surface.

6. Tighten the bolts in the following order.

- bolt (engine bracket 1 and engine) ①

 **32 Nm (3.2 m · kg)**

- bolts (engine bracket 1 and fame) ②

 **16 Nm (1.6 m · kg)**



EAS00194

CAMSHAFTS

CYLINDER HEAD COVER

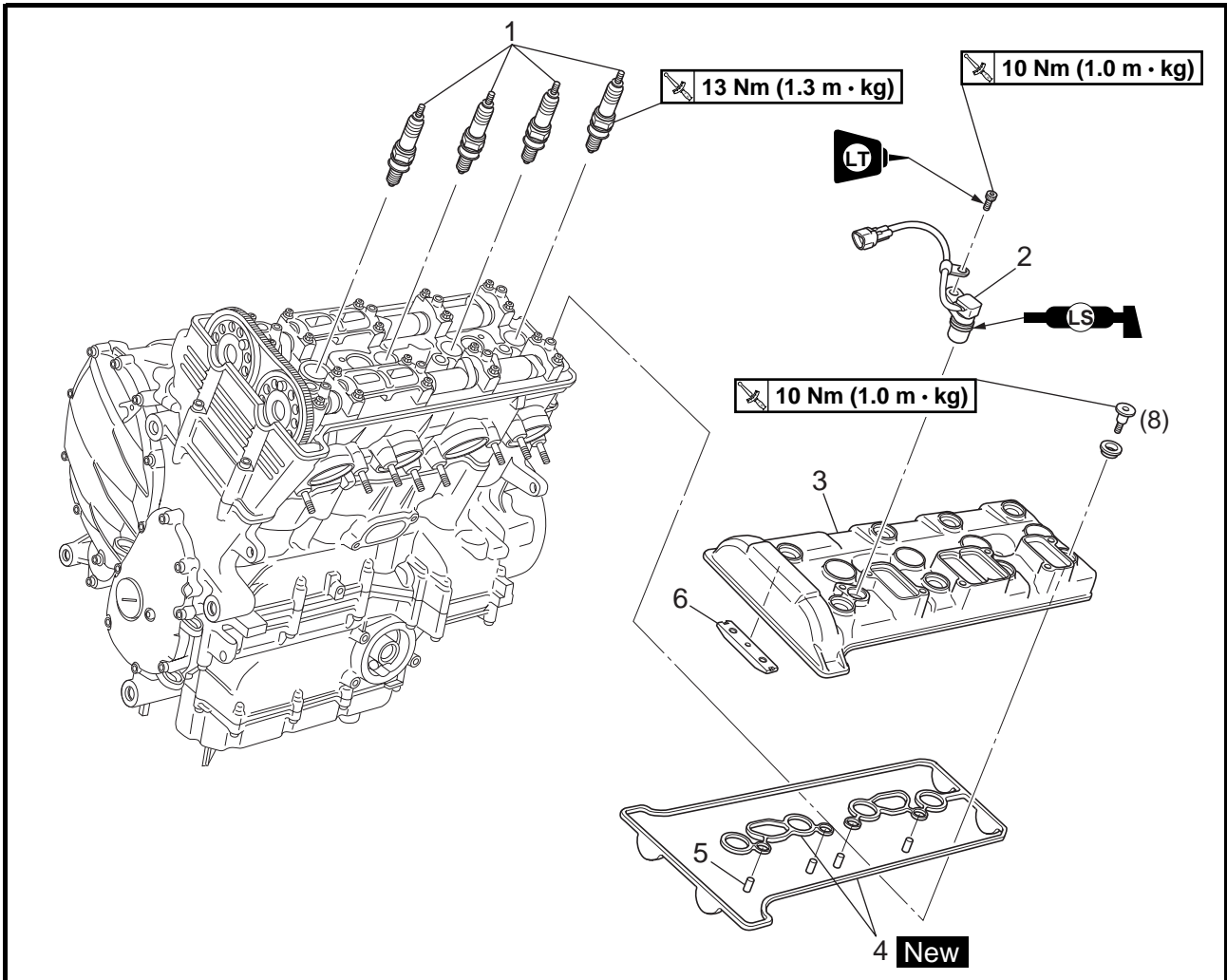

Order	Job/Part	Q'ty	Remarks
	Removing the cylinder head cover		Remove the parts in the order listed.
	Reed valves		Refer to "AIR INDUCTION SYSTEM" in chapter 7.
	Engine oil		Drain. Refer to "CHANGING THE ENGINE OIL" in chapter 3.
1	Spark plug	4	Refer to "INSTALLING THE CAM-SHAFTS".
2	Cylinder identification sensor	1	
3	Cylinder head cover	1	
4	Cylinder head cover gasket	1	
5	Dowel pin	4	
6	Timing chain guide (top side)	1	
			For installation, reverse the removal procedure.



EAS00196

CAMSHAFTS

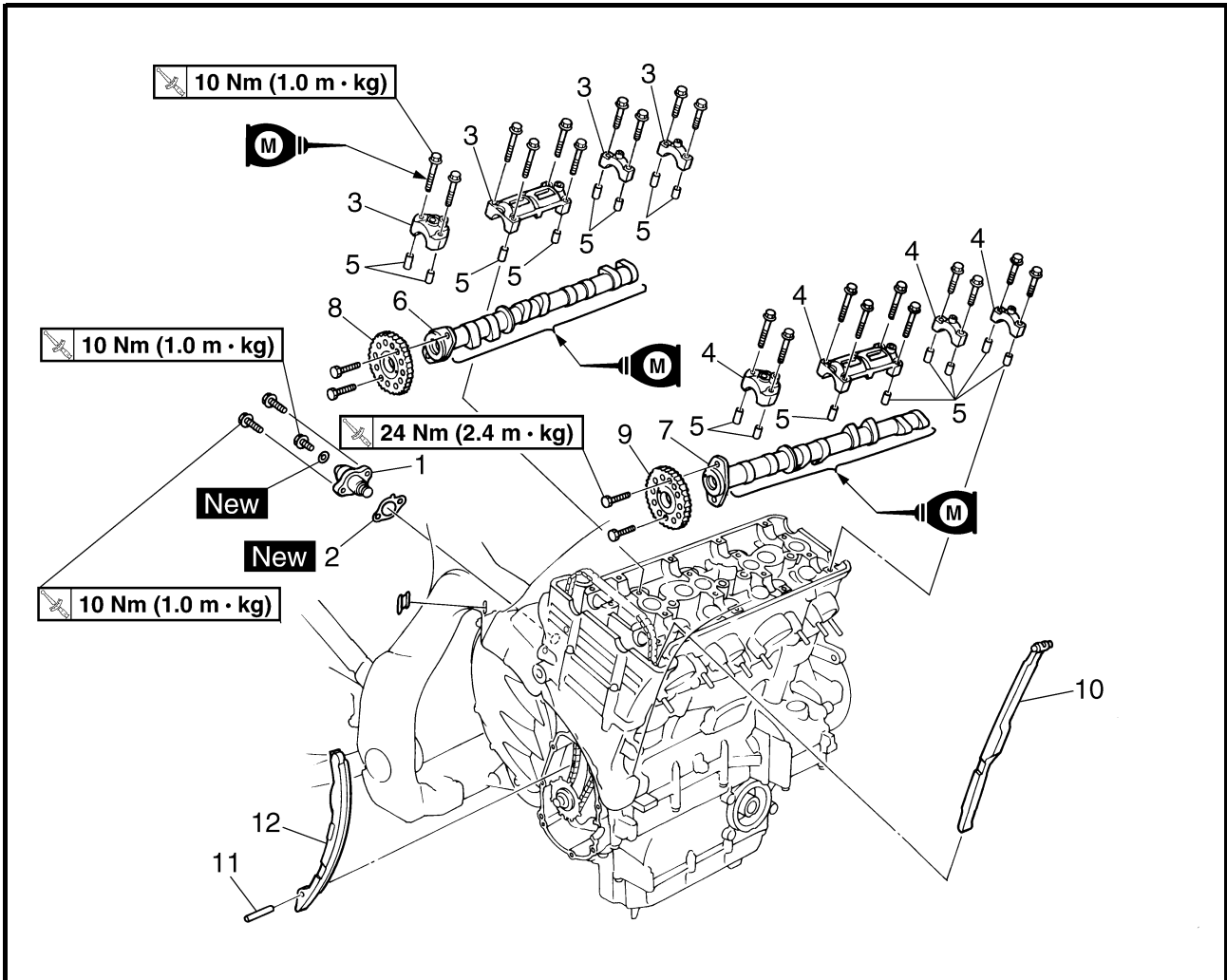

Order	Job/Part	Q'ty	Remarks
	Removing the camshafts		Remove the parts in the order listed.
	Throttle bodies		Refer to "FUEL INJECTION SYSTEM" in chapter 7.
	Pickup coil rotor cover		Refer to "PICKUP COIL ROTOR".
1	Timing chain tensioner	1	Refer to "REMOVING/INSTALLING THE CAMSHAFTS".
2	Timing chain tensioner gasket	1	
3	Intake camshaft cap	4	
4	Exhaust camshaft cap	4	
5	Dowel pin	16	
6	Intake camshaft	1	
7	Exhaust camshaft	1	
8	Intake camshaft sprocket	1	
9	Exhaust camshaft sprocket	1	

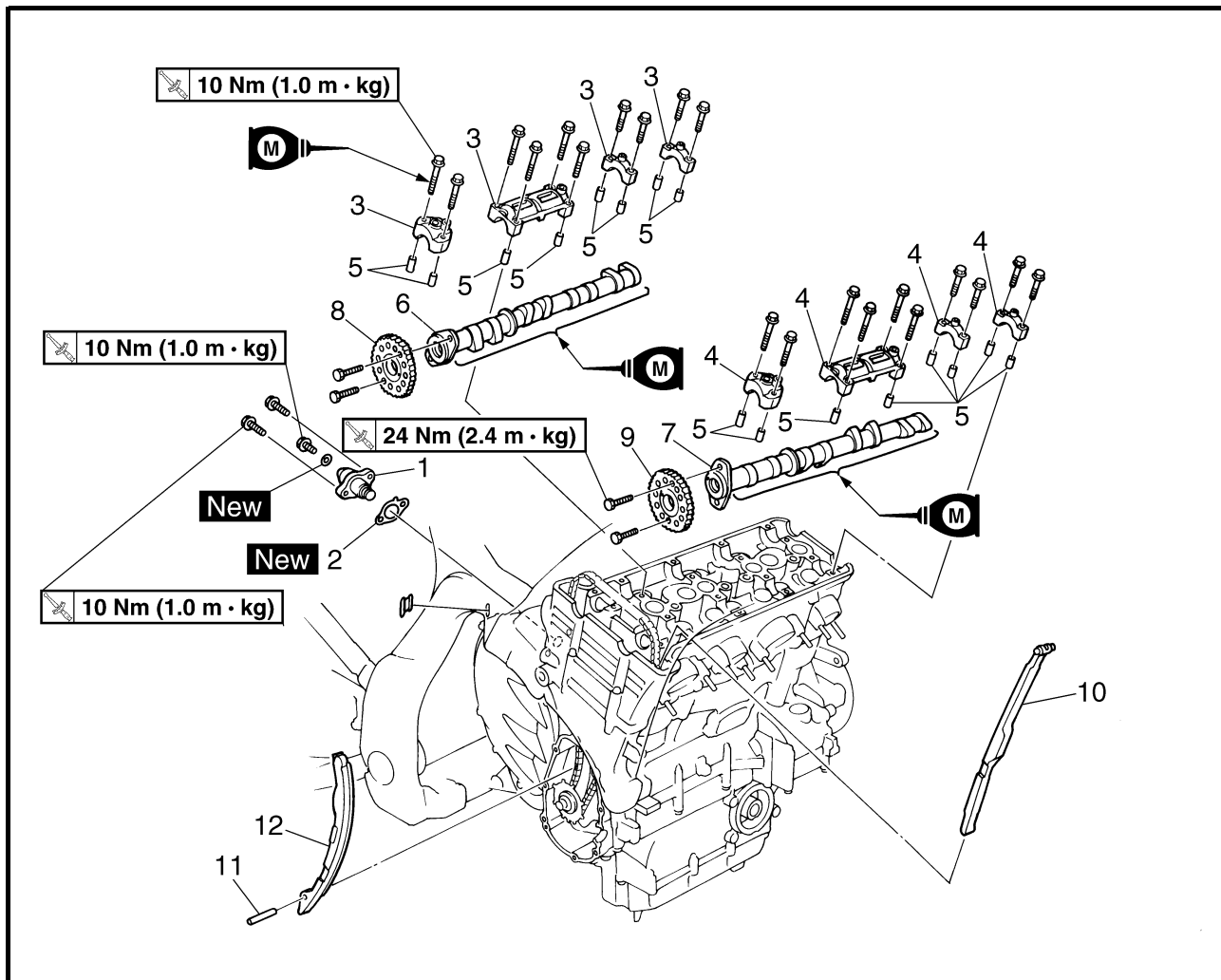

Order	Job/Part	Q'ty	Remarks
10	Timing chain guide (exhaust side)	1	For installation, reverse the removal procedure.
11	Pin	1	
12	Timing chain guide (intake side)	1	

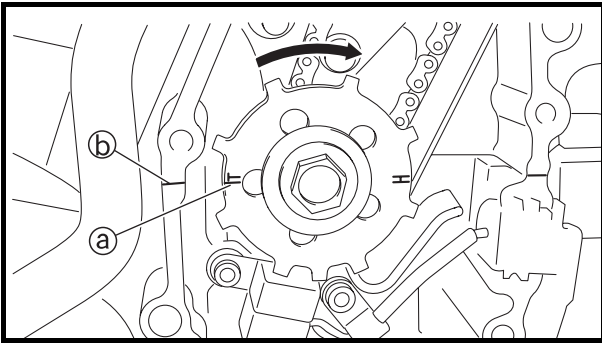

EAS00198

REMOVING THE CAMSHAFTS

1. Align:
 - “T” mark on the pickup coil rotor (with the crankcase mating surface)

-
- a. Turn the crankshaft clockwise.
 - b. When piston #1 is at TDC on the compression stroke, align the “T” mark (a) on the pickup coil rotor with the crankcase mating surface (b).

NOTE: _____
 TDC on the compression stroke can be found when the camshaft lobes are turned away from each other.

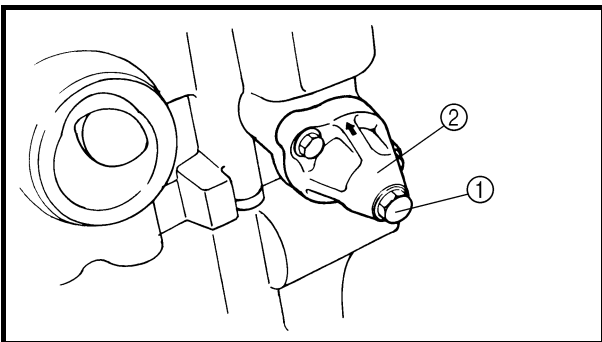

2. Loosen:
 - cap bolt (1)
3. Remove:
 - timing chain tensioner (2)
 - gasket

4. Remove:
 - camshaft caps
 - dowel pins

CAUTION: _____

To prevent damage to the cylinder head, camshafts or camshaft caps, loosen the camshaft cap bolts in stages and in a criss-cross pattern, working from the outside in.

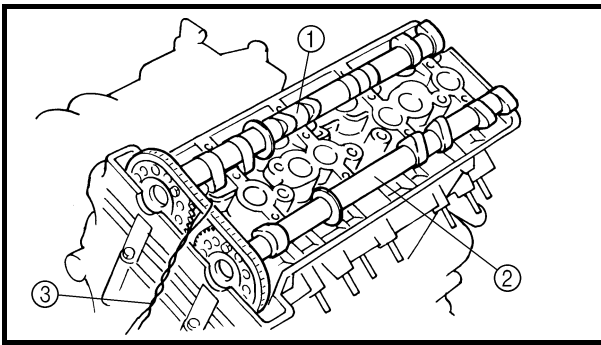

5. Remove:

- intake camshaft ①
- exhaust camshaft ②

NOTE:

To prevent the timing chain from falling into the crankcase, fasten it with a wire ③.

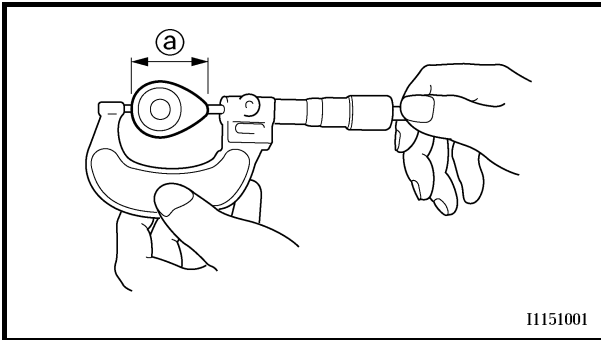

11151001

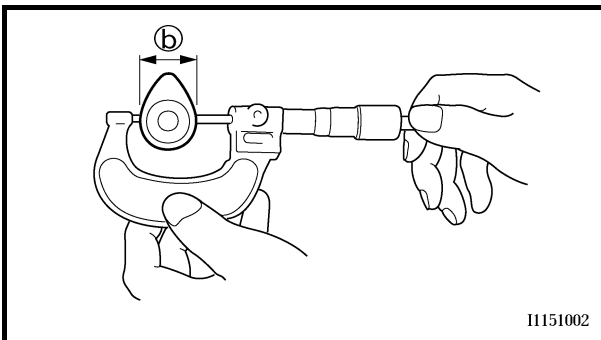

11151002

EAS00204

CHECKING THE CAMSHAFTS

1. Check:

- camshaft lobes
Blue discoloration/pitting/scratches → Replace the camshaft.

2. Measure:

- camshaft lobe dimensions ① and ②
Out of specification → Replace the camshaft.



Minimum cam lobe dimensions

Intake camshaft

① 32.05 mm

② 23.997 mm

Exhaust camshaft

① 32.95 mm

② 24.897 mm

3. Measure:

- camshaft runout
Out of specification → Replace.



Maximum camshaft runout

0.03 mm

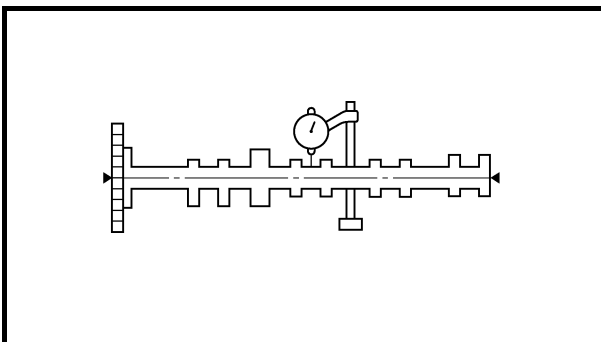

4. Measure:

- camshaft-journal-to-camshaft-cap clearance
Out of specification → Measure the camshaft journal diameter.



Camshaft-journal-to-camshaft-cap clearance

0.028 ~ 0.062 mm

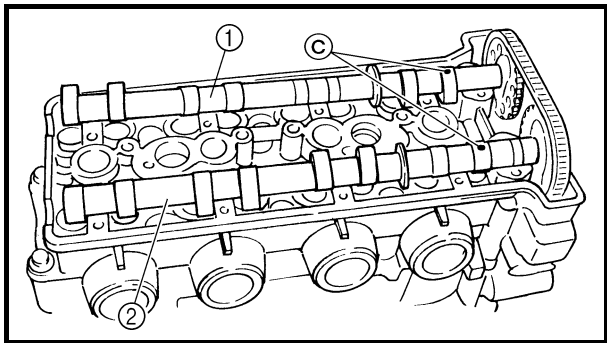

2. Install:
 - exhaust camshaft ①
 - intake camshaft ②
 - (with the camshaft sprockets)

-
- a. Turn the crankshaft clockwise.
 - b. When piston #1 is at TDC on the compression stroke, align the “T” mark Ⓐ on the pickup coil rotor with the crankcase mating surface ⓑ.
 - c. Install the timing chain onto both camshaft sprockets, and then install the camshafts.

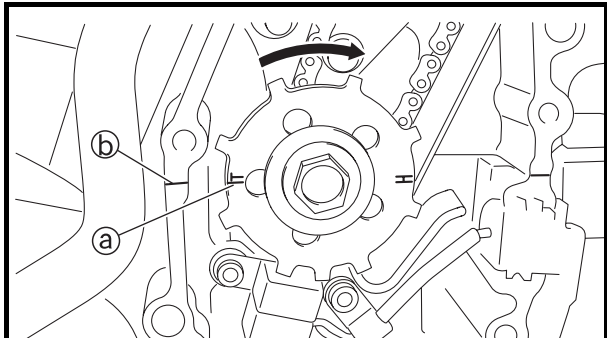

NOTE: _____

- Install the camshafts with the hole ⓐ in the cylinder #4 - cam facing up.
- When installing the timing chain, start with the exhaust camshaft and be sure to keep the timing chain as tight as possible on the exhaust side.
- Make sure the marks ⓑ on the timing chain sprockets are parallel with the edge of the cylinder head.

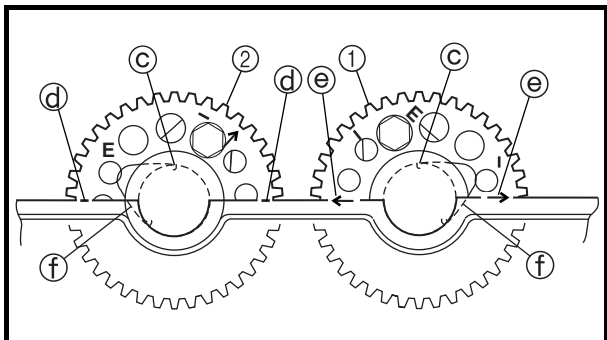

- ⓐ : Intake side “—”
 - ⓑ : Exhaust side “→”
 - Ⓒ : Cylinder #1 - cam
-

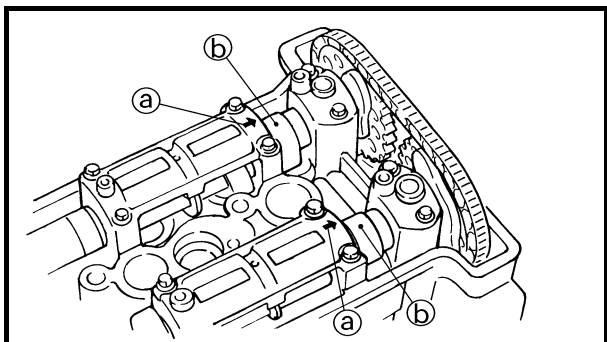

3. Install:
 - dowel pins
 - intake camshaft caps
 - exhaust camshaft caps

NOTE: _____

- The “I” mark refers to the intake camshaft caps and the “E” mark refers to the exhaust camshaft cap.
 - Install the camshaft caps with the arrow mark Ⓐ pointing towards the right side of the engine.
 - Make sure the punch marks ⓑ in the camshaft are aligned with the arrow mark Ⓐ on the camshaft caps.
-



- d. Remove the screwdriver, make sure the timing chain tensioner rod releases, and then tighten the cap bolt to the specified torque.



Cap bolt
10 Nm (1.0 m · kg)

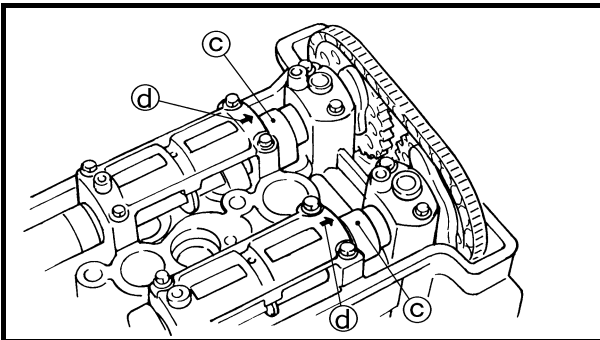
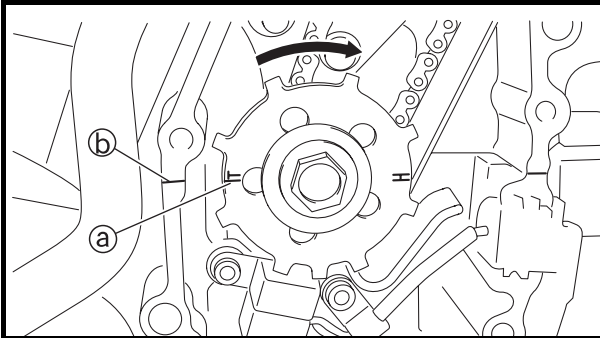

6. Turn:
- crankshaft
(several turns clockwise)
7. Check:
- “T” mark ①
Make sure the “T” mark ① on the pickup coil rotor is aligned with the crankcase mating surface ②.
 - camshaft holes ③
Make sure the holes ③ in the cylinder #4 - cam are aligned with the arrow marks ④ on the camshaft caps.
Out of alignment → Adjust.
Refer to the installation steps above.
8. Measure:
- valve clearance
Out of specification → Adjust.
Refer to “ADJUSTING THE VALVE CLEARANCE” in chapter 3.

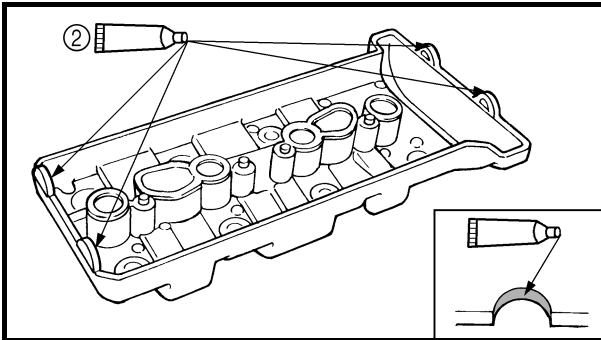
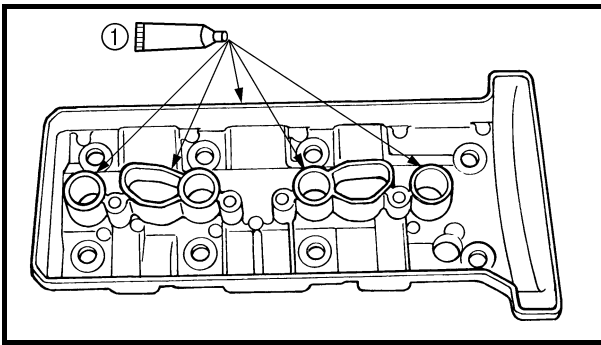

9. Install:

- cylinder head cover gasket **New**
- cylinder head cover

 **10 Nm (1.0 m · kg)**

NOTE:

- Apply bond T1541 ① onto the mating surfaces of the cylinder head cover and cylinder head cover gasket.
- Apply bond YGK8624-C1 ② onto the mating surfaces of the cylinder head cover gasket and cylinder head.
- Tighten the cylinder head cover bolts stages and in a crisscross pattern.



EAS00221

CYLINDER HEAD

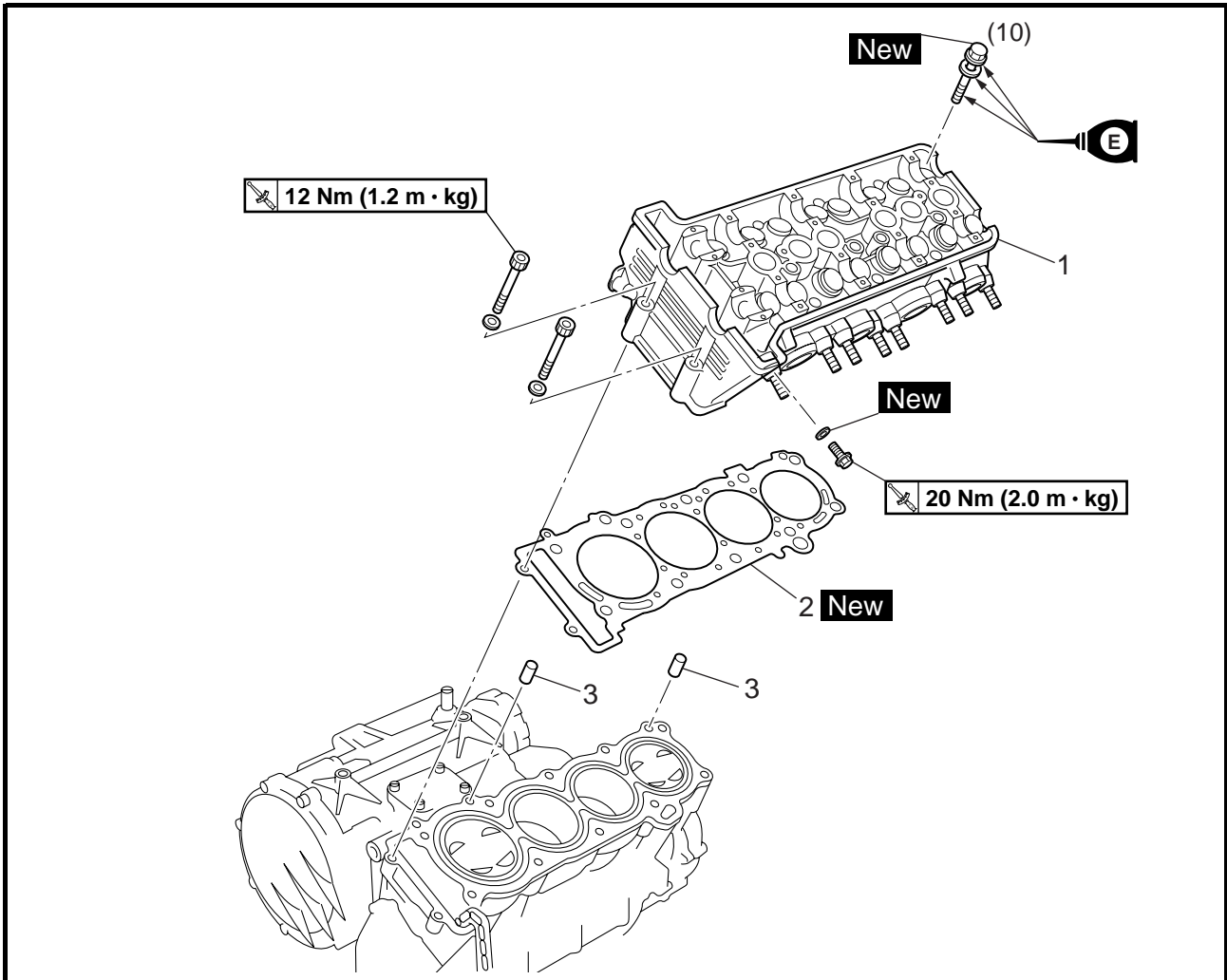

Order	Job/Part	Q'ty	Remarks
	Removing the cylinder head		Remove the parts in the order listed.
	Radiator		Refer to "RADIATOR" in chapter 6.
	Exhaust pipe assembly		Refer to "ENGINE".
	Camshafts		Refer to "CAMSHAFTS".
1	Cylinder head	1	Refer to "INSTALLING THE CYLINDER HEAD".
2	Cylinder head gasket	1	
3	Dowel pin	2	
			For installation, reverse the removal procedure.



EAS00222

REMOVING THE CYLINDER HEAD

1. Remove:

- cylinder head bolts

NOTE:

Loosen each bolt 1/2 of a turn at a time. After all of the bolt are fully loosened, remove them.

EAS00229

CHECKING THE CYLINDER HEAD

1. Eliminate:

- combustion chamber carbon deposits (with a rounded scraper)

NOTE:

Do not use a sharp instrument to avoid damaging or scratching:

- spark plug bore threads
- valve seats

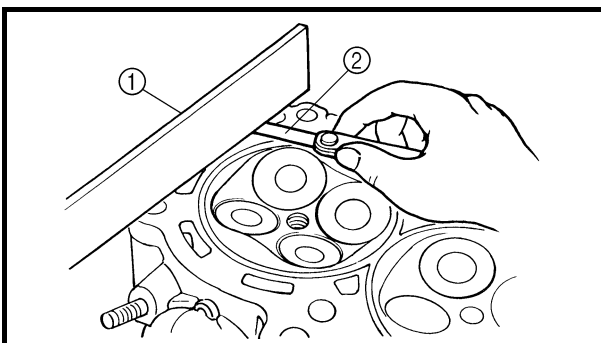
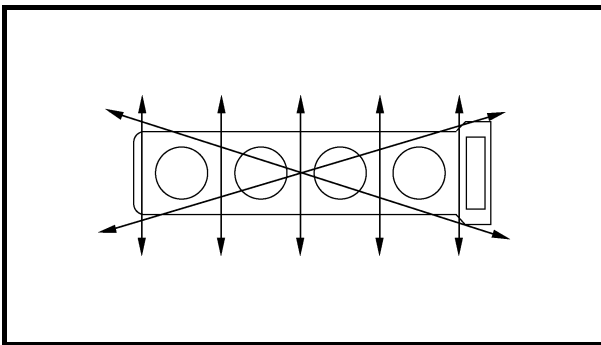

2. Check:

- cylinder head
Damage/scratches → Replace.
- cylinder head water jacket
Mineral deposits/rust → Eliminate.

3. Measure:

- cylinder head warpage
Out of specification → Resurface the cylinder head.



**Maximum cylinder head warpage
0.1 mm**

- Place a straightedge ① and a thickness gauge ② across the cylinder head.
- Measure the warpage.
- If the limit is exceeded, resurface the cylinder head as follows.

- d. Place a 400 ~ 600 grit wet sandpaper on the surface plate and resurface the cylinder head using a figure-eight sanding pattern.

NOTE: _____

To ensure an even surface, rotate the cylinder head several times.

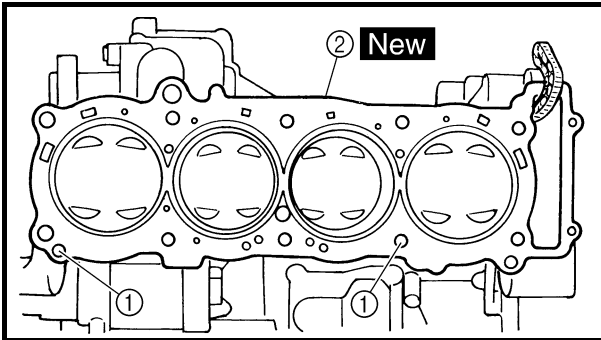

EAS00232

INSTALLING THE CYLINDER HEAD

- 1. Install:
 - dowel pins ①
 - gasket ② **New**

- 2. Install:
 - cylinder head

NOTE: _____

Pass the timing chain through the timing chain cavity.

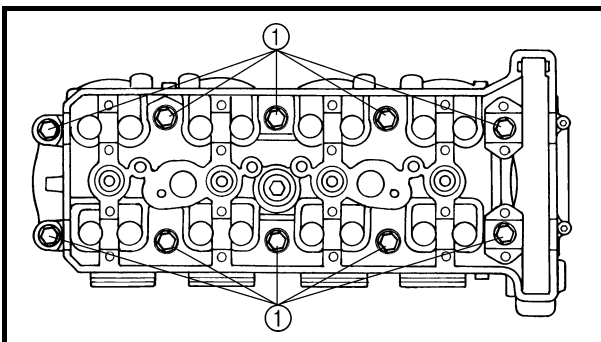

- 3. Tighten:
 - cylinder head bolts (M10) ① **New**

NOTE: _____

- Do not reuse the cylinder head bolts.
- The tightening procedure of the cylinder head bolts is angle controlled, therefore tighten the bolts using the following procedure.

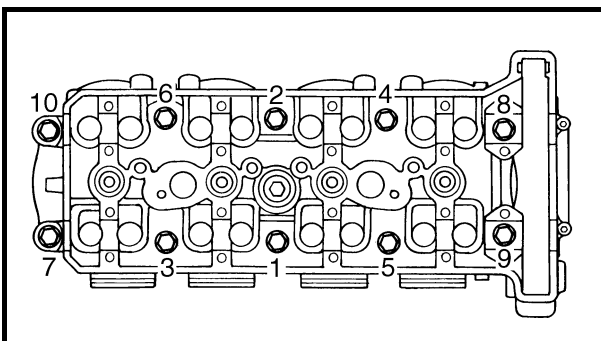

- a. Lubricate the cylinder head bolts and washers with engine oil.
- b. Install the washers and cylinder head bolts.
- c. Tighten the cylinder head bolts in the proper tightening sequence as shown.

	<p>Cylinder head bolt (M10) 1st 25 Nm (2.5 m · kg)</p>
---	---



d. Loosen and retighten the cylinder head bolts in the proper tightening sequence as shown.



Cylinder head bolt (M10)
2nd
25 Nm (2.5 m · kg)

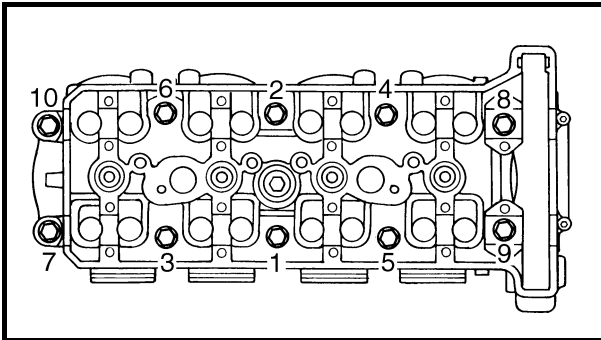

e. Tighten the cylinder head bolts further to reach the specified angle 180° in the proper tightening sequence as shown.



Cylinder head bolt (M10)
Final
Specified angle 180°

⚠ WARNING

When the bolts are tightened more than the specified angle, do not loosen the bolt and then retighten it.

Replace the bolt with a new one and perform the procedure again.

CAUTION:

- Do not use a torque wrench to tighten the bolt to the specified angle.
- Tighten the bolt until it is at the specified angle.

NOTE:

When using a hexagonal bolt, note that the angle from one corner to another is 60°.

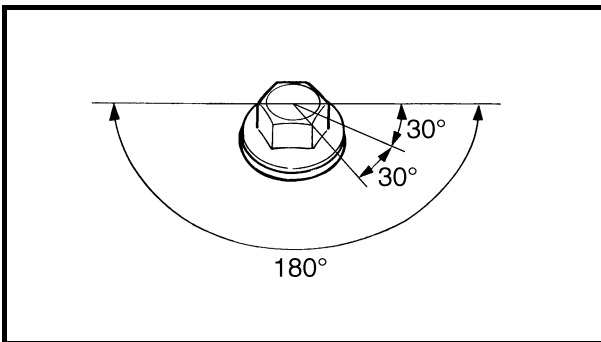

CYLINDER HEAD

ENG

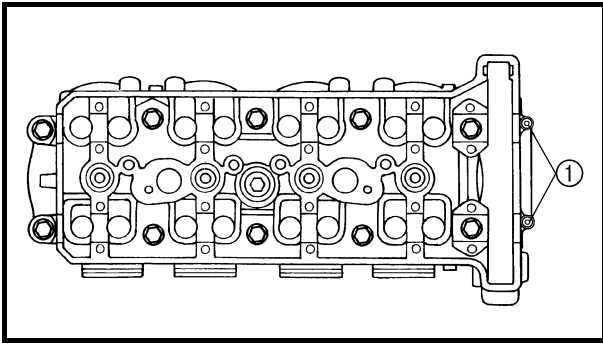

4. Tighten:

- cylinder head bolts (M6) ①

 12 Nm (1.2 m · kg)



EAS00236

VALVES AND VALVE SPRINGS

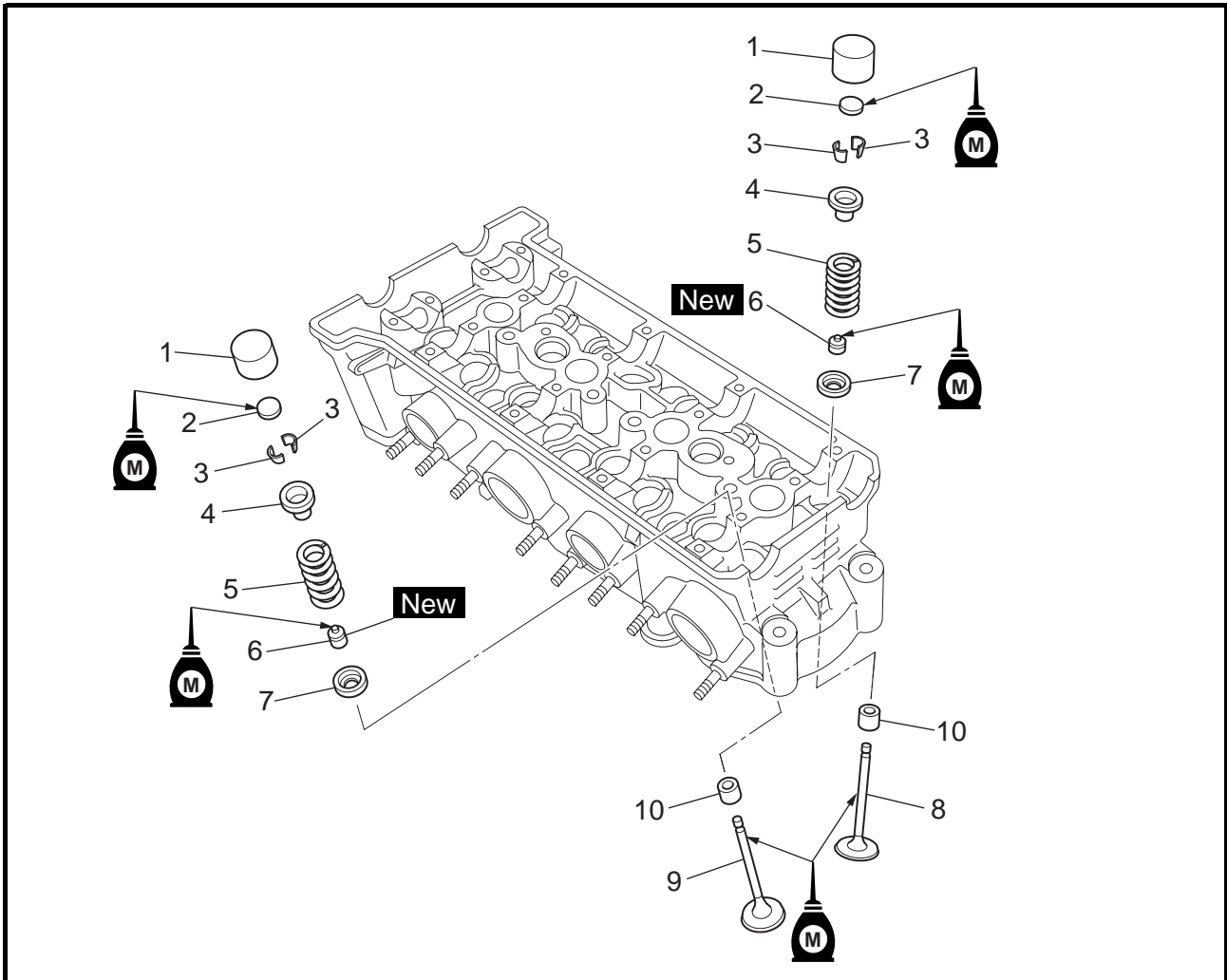

Order	Job/Part	Q'ty	Remarks
	Removing the valves and valve springs		Remove the parts in the order listed.
	Cylinder head		Refer to "CYLINDER HEAD".
1	Valve lifter	16	Refer to "REMOVING/INSTALLING THE VALVES".
2	Valve pad	16	
3	Valve cotter	32	
4	Upper spring seat	16	
5	Valve spring	16	
6	Oil seal	16	
7	Lower spring seat	16	
8	Intake valve	4	
9	Exhaust valve	4	
10	Valve guide	16	
			For installation, reverse the removal procedure.

EAS00237

REMOVING THE VALVES

The following procedure applies to all of the valves and related components.

NOTE: _____

Before removing the internal parts of the cylinder head (e.g., valves, valve springs, valve seats), make sure the valves properly seal.

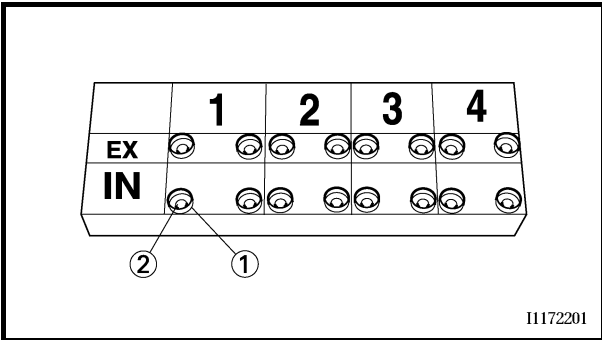

I1172201

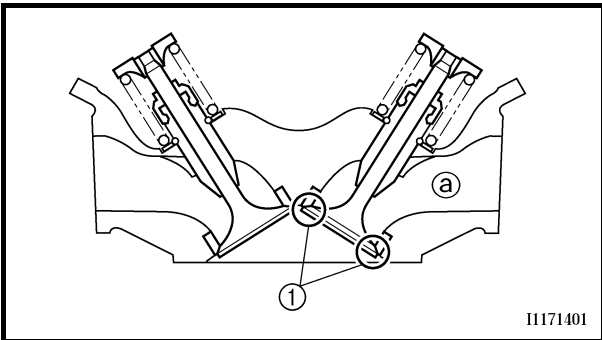

I1171401

1. Remove:

- valve lifter ①
- valve pad ②

NOTE: _____

Make a note of the position of each valve lifter and valve pad so that they can be reinstalled in their original place.

2. Check:

- valve
(for leakage)

Leakage at the valve seat → Check the valve face, valve seat, and valve seat width. Refer to “CHECKING THE VALVE SEATS”.



- a. Pour a clean solvent ① into the intake and exhaust ports.
- b. Check that the valves properly seal.

NOTE: _____

There should be no leakage at the valve seat ①.



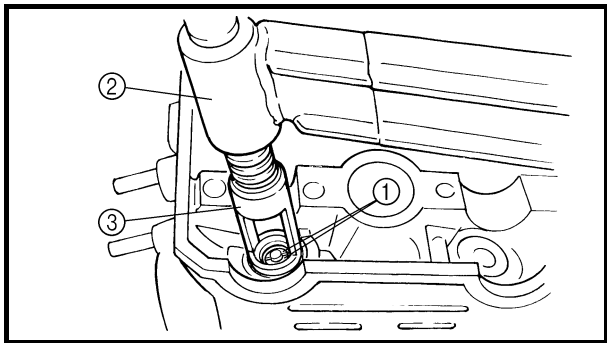

3. Remove:
- valve cotters ①

NOTE: _____
 Remove the valve cotters by compressing the valve spring with the valve spring compressor ② and attachment ③.

	<p>Valve spring compressor 90890-04019 Attachment 90890-04108</p>
---	--

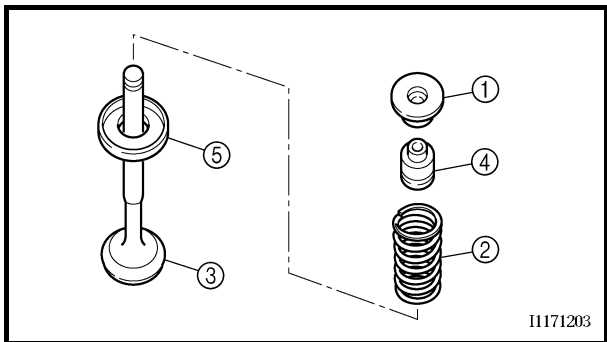

4. Remove:
- upper spring seat ①
 - valve spring ②
 - oil seal ③
 - lower spring seat ④
 - valve ⑤

NOTE: _____
 Identify the position of each part very carefully so that it can be reinstalled in its original place.

EAS00239

CHECKING THE VALVES AND VALVE GUIDES

The following procedure applies to all of the valves and valve guides.



3. Eliminate:
 - carbon deposits
(from the valve face and valve seat)
4. Check:
 - valve face
Pitting/wear → Grind the valve face.
 - valve stem end
Mushroom shape or diameter larger than the body of the valve stem → Replace the valve.
5. Measure:
 - valve margin thickness \textcircled{a}
Out of specification → Replace the valve.

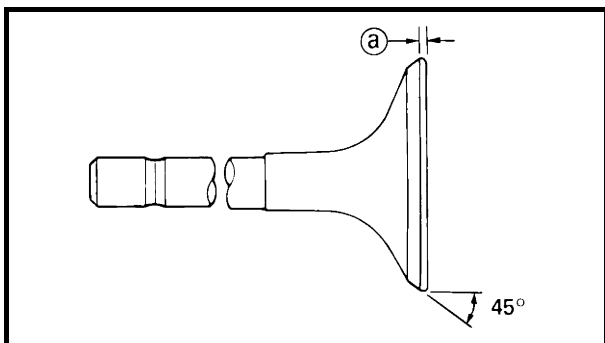

Valve margin thickness
 Intake : 0.8 ~ 1.2 mm
 Exhaust : 0.5 ~ 0.9 mm

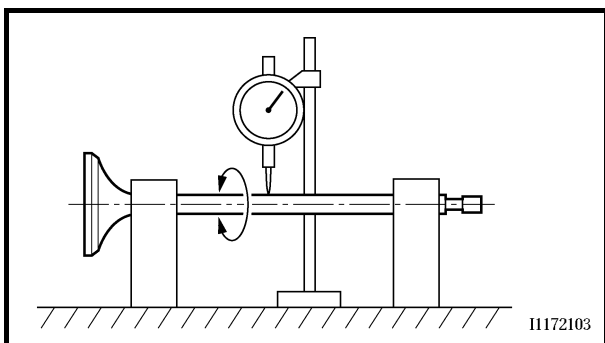

6. Measure:
 - valve stem runout
Out of specification → Replace the valve.

NOTE:

- When installing a new valve, always replace the valve guide.
- If the valve is removed or replaced, always replace the oil seal.



Valve stem runout
 0.01 mm

EAS00240

CHECKING THE VALVE SEATS

The following procedure applies to all of the valves and valve seats.

1. Eliminate:
 - carbon deposits
(from the valve face and valve seat)
2. Check:
 - valve seat
Pitting/wear → Replace the cylinder head.

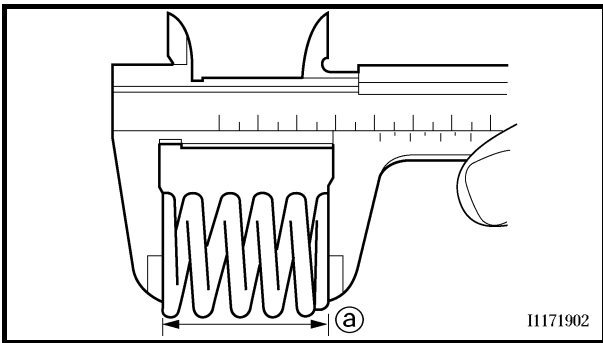
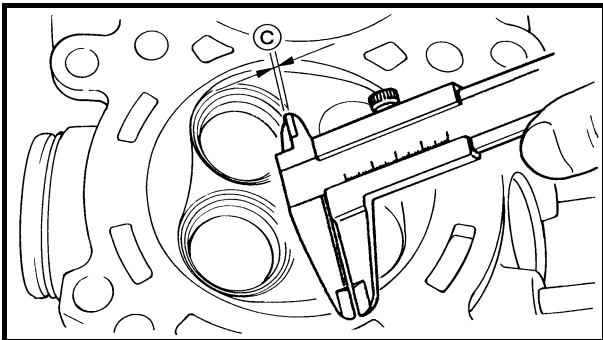
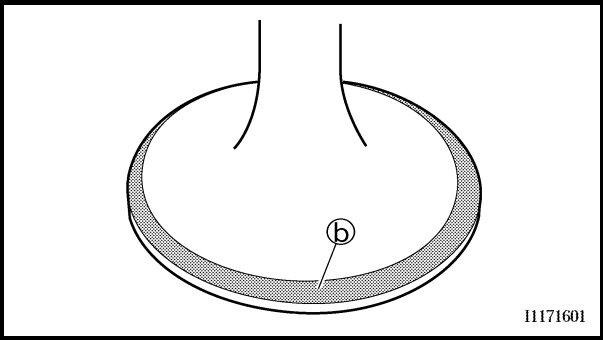
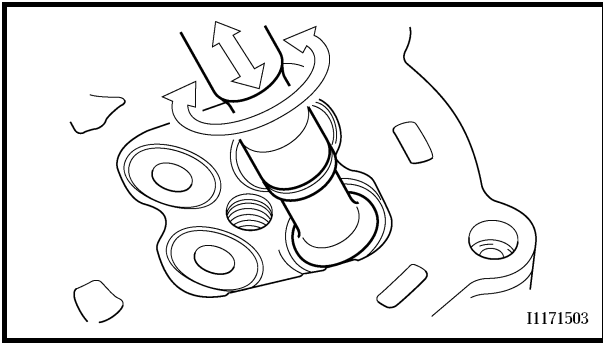

- c. Install the valve into the cylinder head.
- d. Turn the valve until the valve face and valve seat are evenly polished, then clean off all of the lapping compound.

NOTE:
For the best lapping results, lightly tap the valve seat while rotating the valve back and forth between your hands.

- e. Apply a fine lapping compound to the valve face and repeat the above steps.
- f. After every lapping procedure, be sure to clean off all of the lapping compound from the valve face and valve seat.
- g. Apply Mechanic's blueing dye (Dykem) (b) onto the valve face.
- h. Install the valve into the cylinder head.
- i. Press the valve through the valve guide and onto the valve seat to make a clear impression.
- j. Measure the valve seat width (c) again. If the valve seat width is out of specification, reface and lap the valve seat.



EAS00241

CHECKING THE VALVE SPRINGS

The following procedure applies to all of the valve springs.

- 1. Measure:
 - valve spring free length (a)
 Out of specification → Replace the valve spring.

	Valve spring free length (intake and exhaust)
	39.7 mm
	<Limit> : 37.7 mm

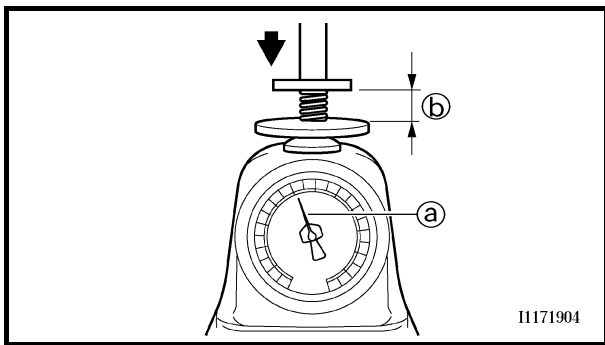

2. Measure:
- compressed valve spring force (a)
Out of specification → Replace the valve spring.
 - Installed length (b)

	<p>Compressed valve spring force (installed) 13.9 ~ 16.1 kg at 33 mm</p>
---	---

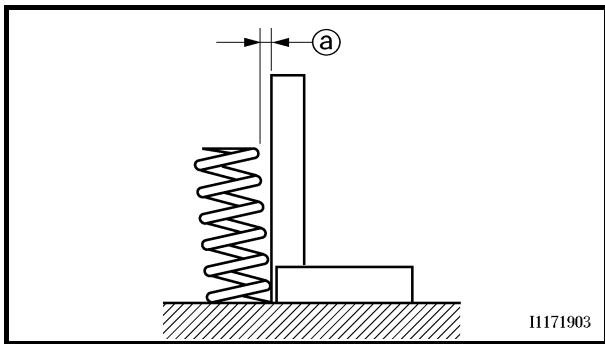

3. Measure:
- valve spring tilt (a)
Out of specification → Replace the valve spring.

	<p>Maximum valve spring tilt 1.7 mm</p>
---	--

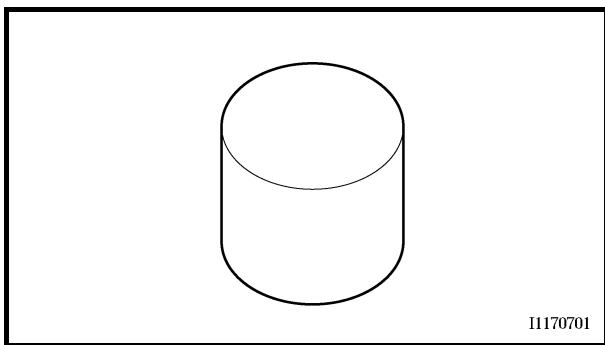

EAS00242

CHECKING THE VALVE LIFTERS

The following procedure applies to all of the valve lifters.

1. Check:
- valve lifter
Damage/scratches → Replace the valve lifters and cylinder head.

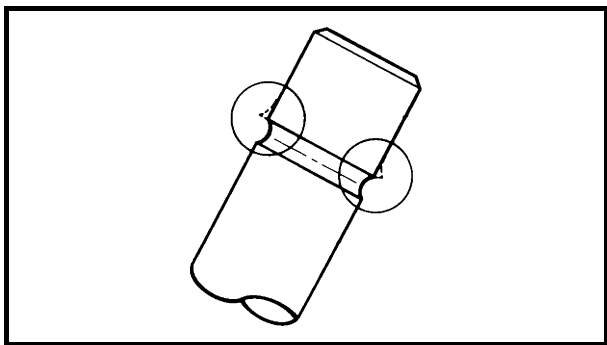

EAS00249

INSTALLING THE VALVES

The following procedure applies to all of the valves and related components.

1. Deburr:
 - valve stem end
(with an oil stone)

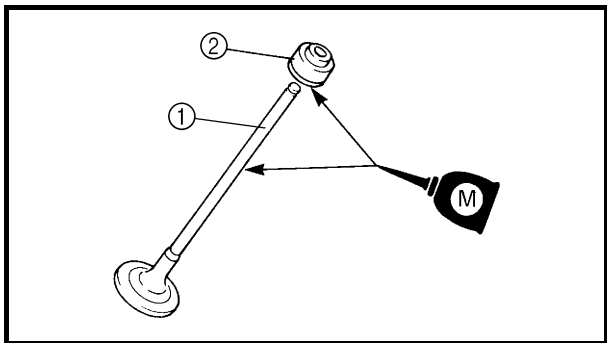

2. Lubricate:
 - valve stem ①
 - oil seal ②
 (with the recommended lubricant)

	Recommended lubricant Molybdenum disulfide oil
--	---

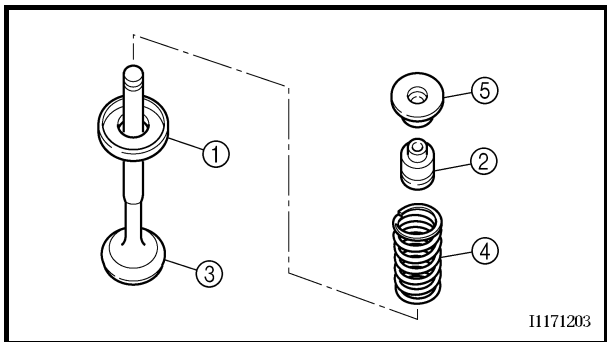

11171203

3. Install:
 - valve ①
 - lower spring seat ②
 - oil seal ③
 - valve spring ④
 - upper spring seat ⑤
 (into the cylinder head)

NOTE:

- Make sure each valve is installed in its original place.
- Install the valve spring with the larger pitch ① facing up.

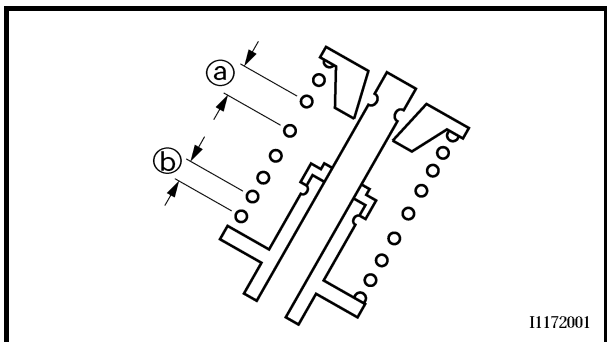

11172001

- ② Smaller pitch

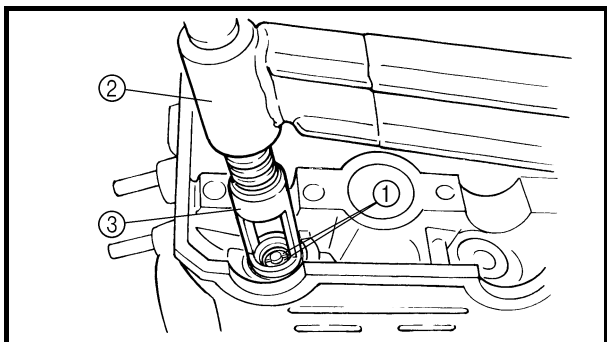

4. Install:
- valve cotters ①

NOTE: _____
 Install the valve cotters by compressing the valve spring with the valve spring compressor ② and attachment ③.



Valve spring compressor
90890-04019
Attachment
90890-04108

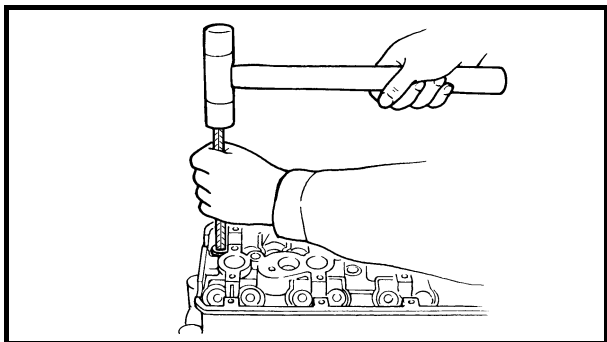

5. To secure the valve cotters onto the valve stem, lightly tap the valve tip with a soft-face hammer.

CAUTION: _____
Hitting the valve tip with excessive force could damage the valve.

6. Lubricate:
- valve pad
 - valve lifter
 (with the recommended lubricant)



Recommended lubricant
Molybdenum disulfide oil

7. Install:
- valve pad
 - valve lifter

NOTE: _____
 • The valve lifter must move smoothly when rotated with a finger.
 • Each valve lifter and valve pad must be reinstalled in its original position.

EAS00343

GENERATOR AND STARTER CLUTCH GENERATOR ROTOR AND STARTER CLUTCH

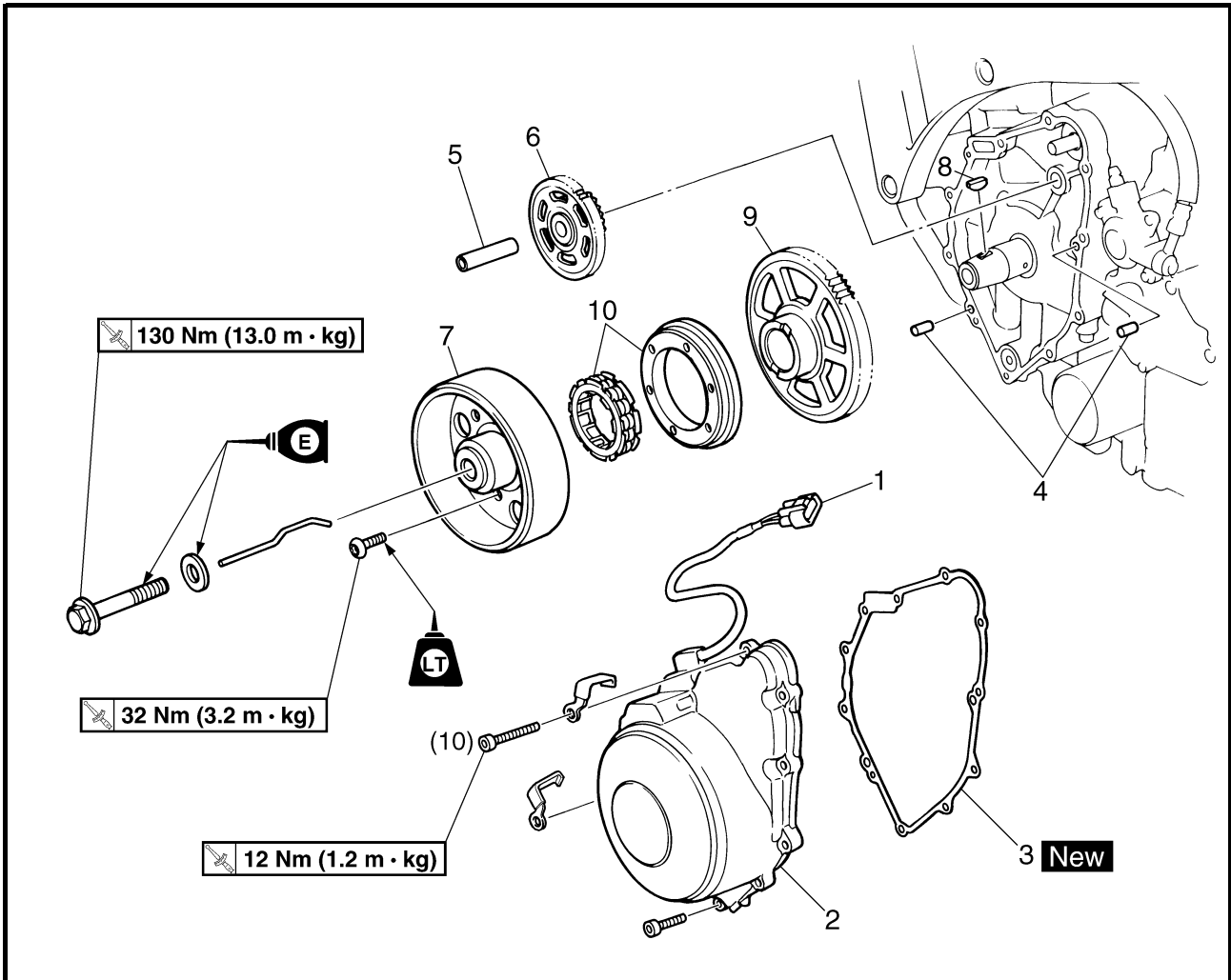

Order	Job/Part	Q'ty	Remarks
	Removing the generator rotor and starter clutch		Remove the parts in the order listed.
	Fuel tank/seats/T-bar/rubber seat		Refer to "SEATS AND FUEL TANK" in chapter 3.
	Side covers/front cowling assembly		Refer to "COWLINGS AND COVERS" in chapter 3.
	Engine oil		Drain. Refer to "CHANGING THE ENGINE OIL" in chapter 3.
1	Stator assembly coupler	1	Disconnect.
2	Generator cover	1	Refer to "REMOVING THE GENERATOR".
3	Generator cover gasket	1	
4	Dowel pin	2	

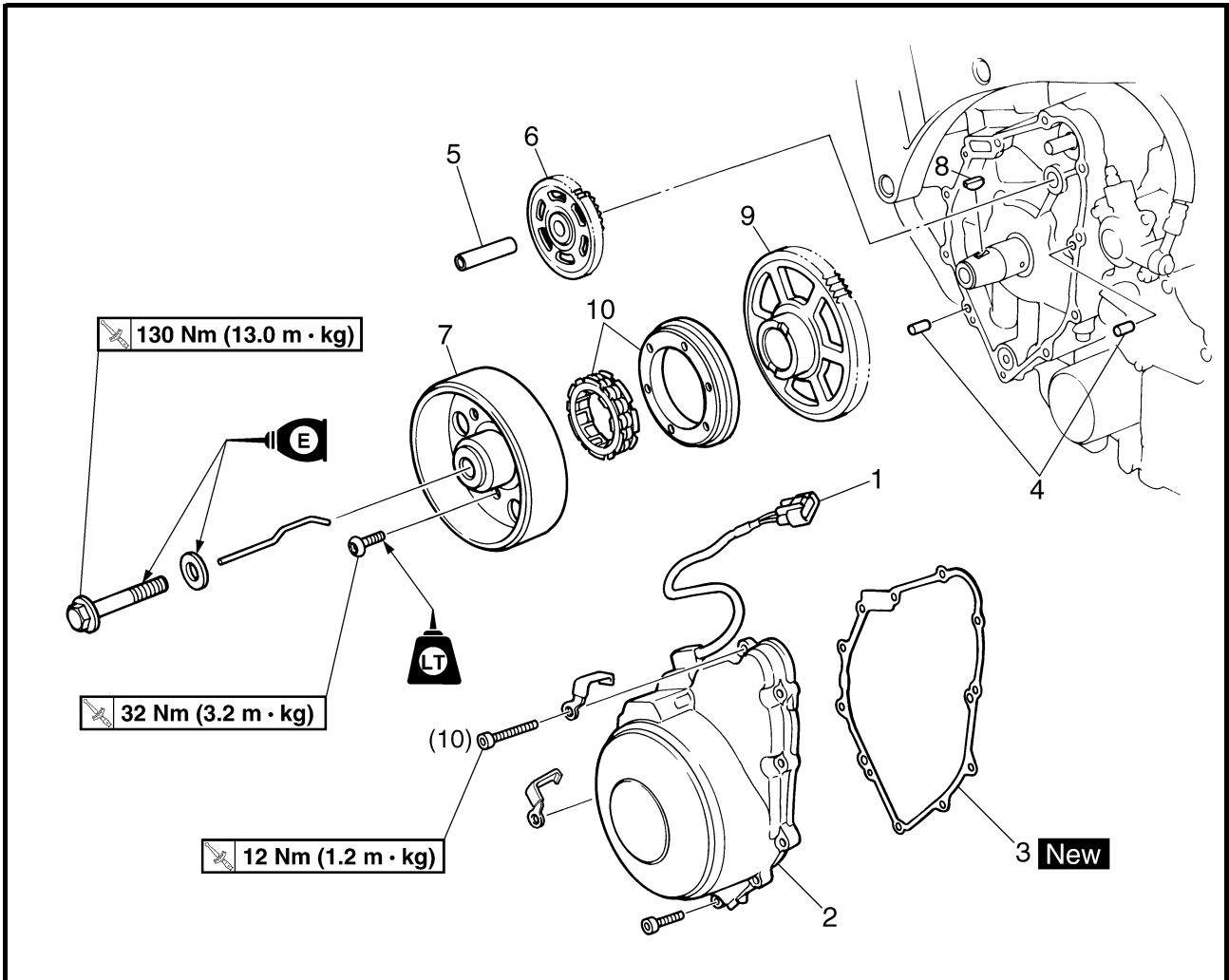

Order	Job/Part	Q'ty	Remarks
5	Starter clutch idle gear shaft	1	Refer to "REMOVING/INSTALLING THE GENERATOR". Refer to "REMOVING/INSTALLING THE STARTER CLUTCH". For installation, reverse the removal procedure.
6	starter clutch idle gear	1	
7	Generator rotor	1	
8	Woodruff key	1	
9	Starter clutch gear	1	
10	Starter clutch	1	

STATOR ASSEMBLY

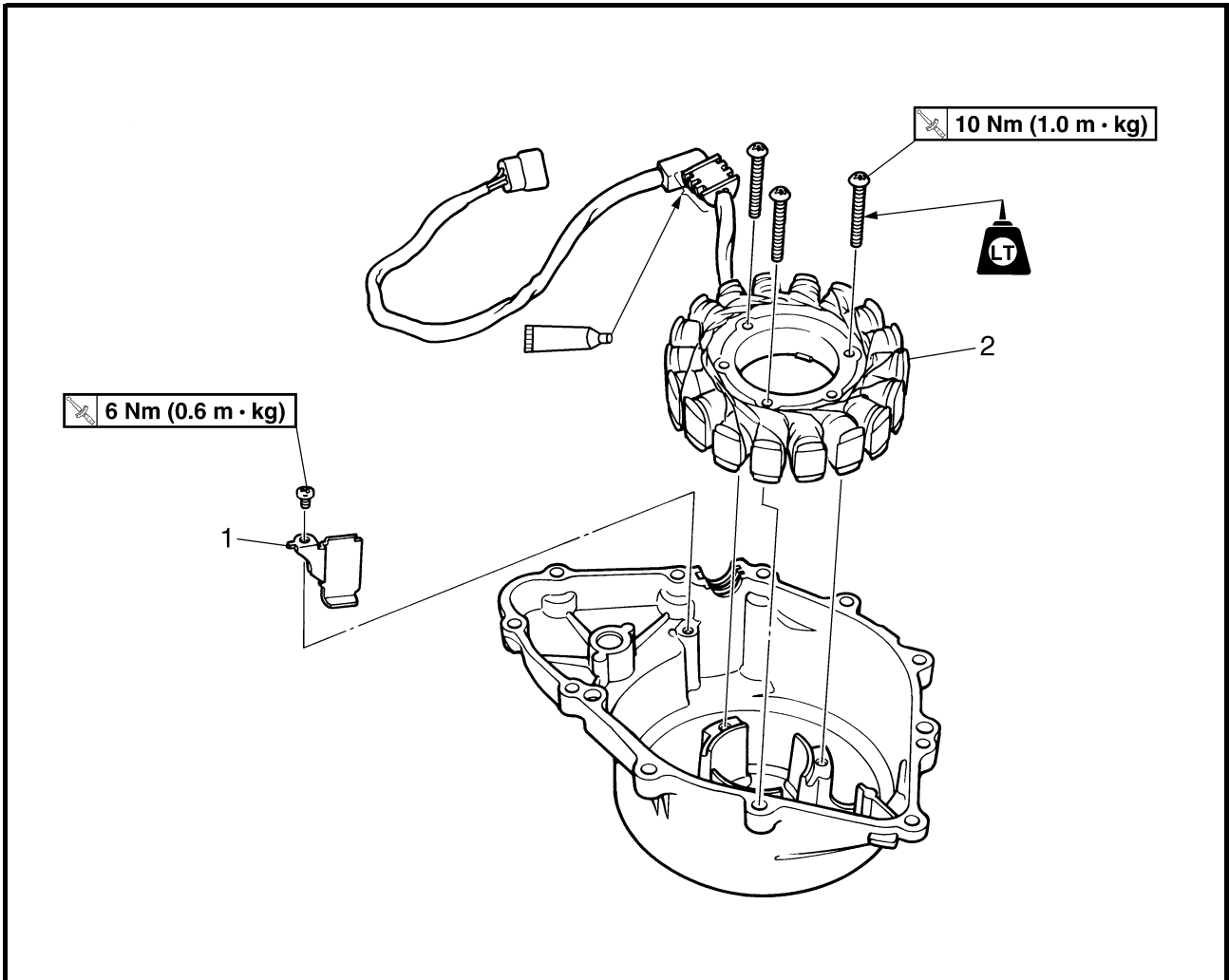

Order	Job/Part	Q'ty	Remarks
	Removing the stator assembly		Remove the parts in the order listed.
1	Lead holder	1	Refer to "INSTALLING THE GENERATOR".
2	Stator assembly	1	
			For installation, reverse the removal procedure.

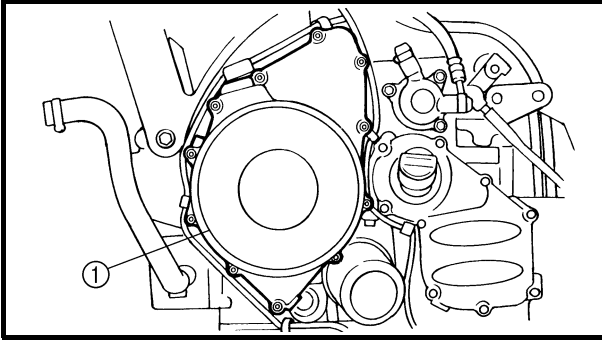

EAS00346

REMOVING THE GENERATOR

1. Remove:

- generator cover ①

NOTE:

Loosen each bolt 1/4 of a turn at a time, in stages and in a crisscross pattern. After all of the bolts are fully loosened, remove them.

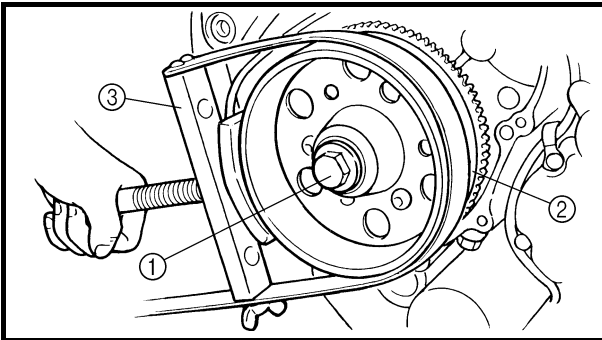

2. Remove:

- generator rotor bolt ①
- washer

NOTE:

While holding the generator rotor ② with the sheave holder ③, loosen the generator rotor bolt.



Sheave holder
90890-01701

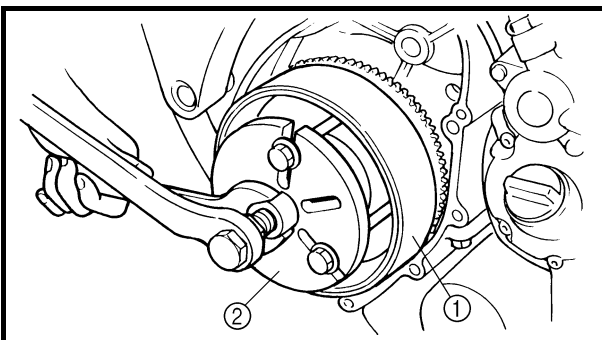

3. Remove:

- generator rotor ①
(with the flywheel puller ②)
- woodruff key



Flywheel puller
90890-01362

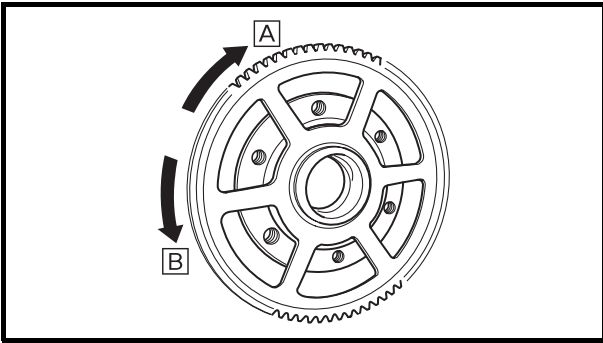

- b. When turning the starter clutch drive gear clockwise **A**, the starter clutch and the starter clutch drive gear should engage, otherwise the starter clutch is faulty and must be replaced.
- c. When turning the starter clutch drive gear counterclockwise **B**, it should turn freely, otherwise the starter clutch is faulty and must be replaced.

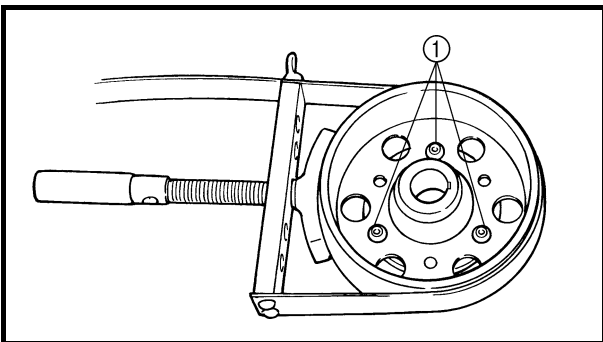



EAS00355

INSTALLING THE STARTER CLUTCH

1. Install:

- starter clutch

- starter clutch bolts ① 

 32 Nm (3.2 m · kg)

NOTE:

While holding the generator rotor with the sheave holder, tighten the starter clutch bolt.



Sheave holder 90890-01701
--

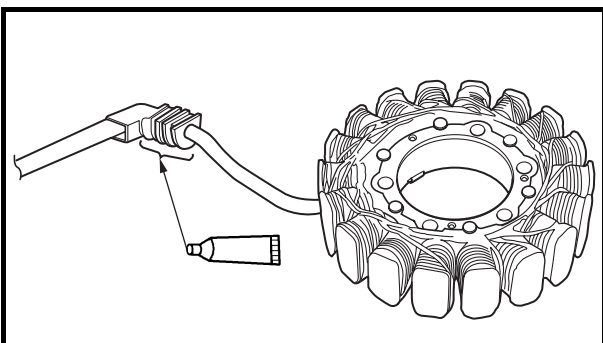

EAS00354

INSTALLING THE GENERATOR

1. Apply:

- sealant

(onto the stator assembly lead grommet)



Yamaha bond No. 1215 90890-85505

GENERATOR AND STARTER CLUTCH

ENG

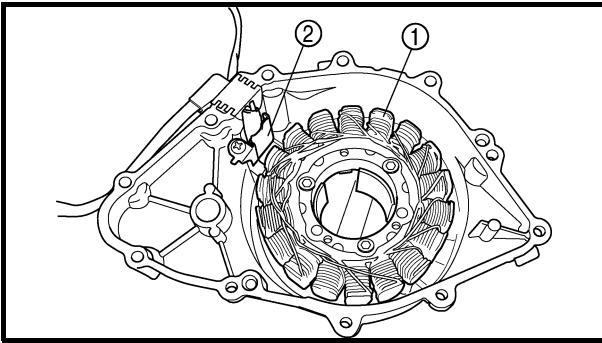

2. Install:

- stator assembly ①



10 Nm (1.0 m · kg)

- lead holder ②

6 Nm (0.6 m · kg)

3. Install:

- woodruff key
- generator rotor
- washer
- generator rotor bolt

NOTE:

- Clean the tapered portion of the crankshaft and the generator rotor hub.
- When installing the generator rotor, make sure the woodruff key is properly seated in the keyway of the crankshaft.
- Lubricate the generator rotor bolt and washer with engine oil.

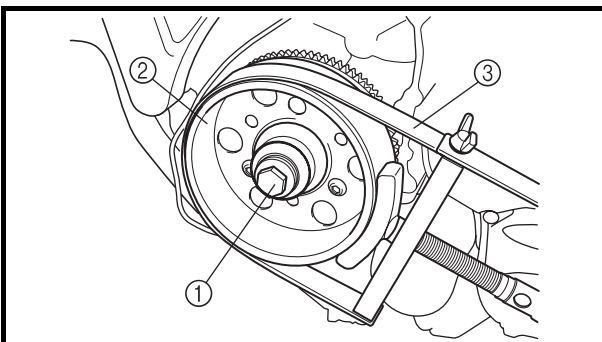

4. Tighten:

- generator rotor bolt ①

130 Nm (13.0 m · kg)

NOTE:

While holding the generator rotor ② with the sheave holder ③, tighten the generator rotor bolt.



Sheave holder
90890-01701



PICKUP COIL ROTOR

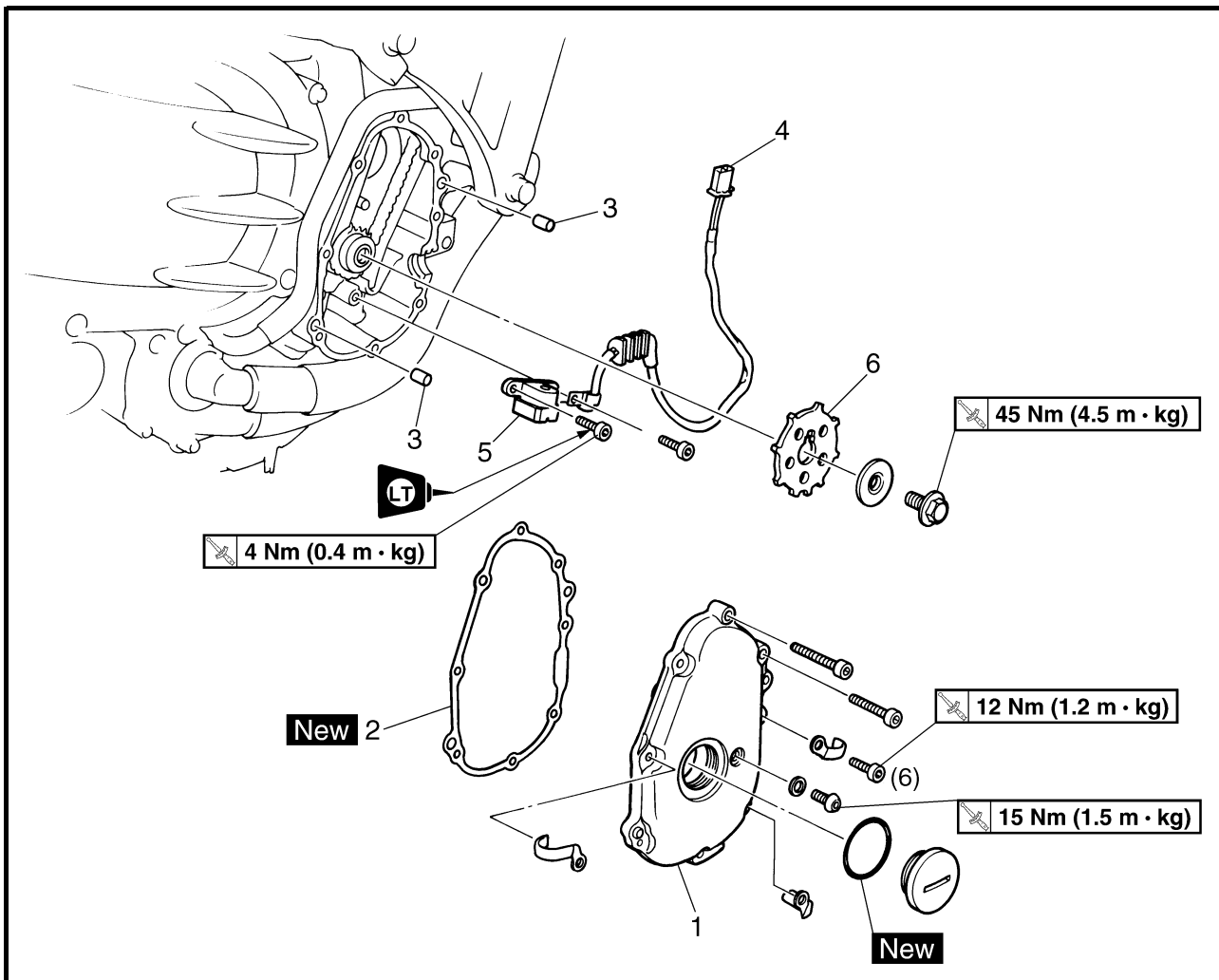

Order	Job/Part	Q'ty	Remarks
	Removing the pickup coil rotor		Remove the parts in the order listed.
	Fuel tank/seats/T-bar/rubber seat		Refer to "SEATS AND FUEL TANK" in chapter 3.
	Air filter case		Refer to "AIR FILTER CASE" in chapter 3.
	Side covers/front cowling assembly		Refer to "COWLINGS AND COVERS" in chapter 3.
	Engine oil		Drain. Refer to "CHANGING THE ENGINE OIL" in chapter 3.
	Generator cover		Refer to "GENERATOR ROTOR AND STARTER CLUTCH".
1	Pickup coil rotor cover	1	Refer to "REMOVING/INSTALLING THE PICKUP COIL ROTOR".
2	Pickup coil rotor cover gasket	1	

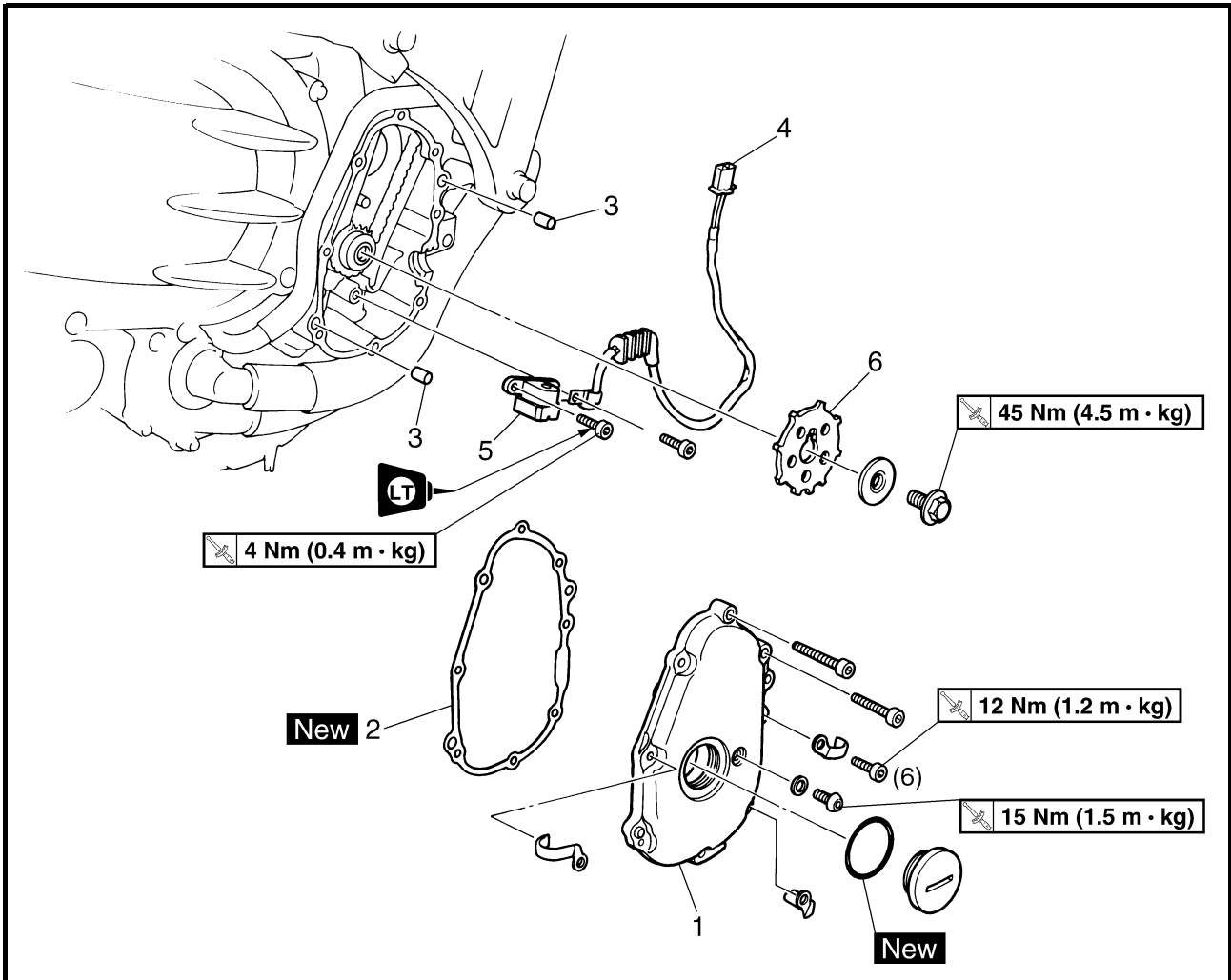

Order	Job/Part	Q'ty	Remarks
3	Dowel pin	2	
4	Crankshaft position sensor coupler	1	Disconnect.
5	Crankshaft position sensor	1	Refer to "INSTALLING THE PICKUP COIL ROTOR".
6	Pickup coil rotor	1	Refer to "REMOVING/INSTALLING THE PICKUP COIL ROTOR". For installation, reverse the removal procedure.

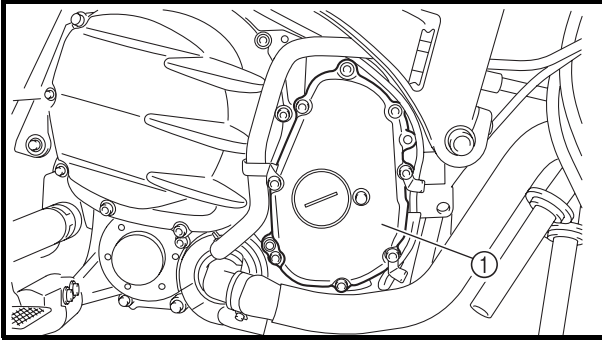

REMOVING THE PICKUP COIL ROTOR

1. Remove:

- pickup coil rotor cover ①

NOTE: _____

Loosen each bolt 1/4 of a turn at a time, in stages and in a crisscross pattern. After all of the bolts are fully loosened, remove them.

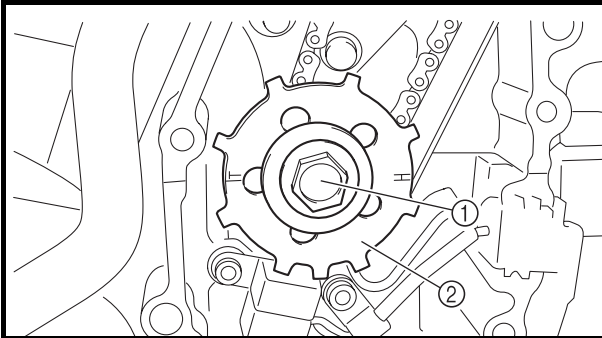

2. Remove:

- pickup coil rotor bolt ①
- washer
- pickup coil rotor ②

NOTE: _____

While holding the generator rotor ③ with the sheave holder ④, remove the pickup coil rotor bolt.

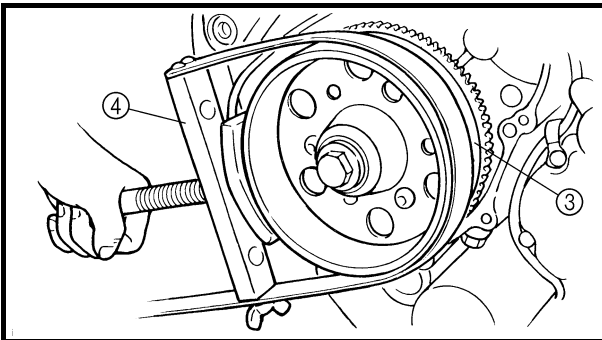

Sheave holder
90890-01701

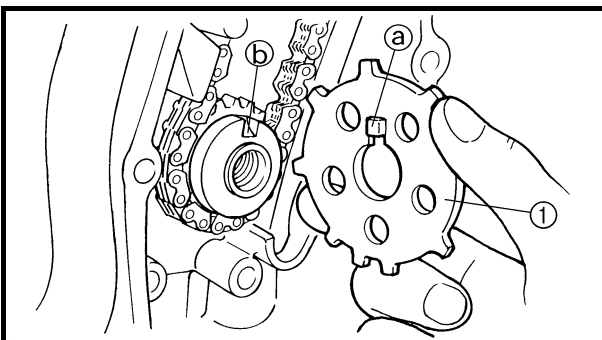

INSTALLING THE PICKUP COIL ROTOR

1. Install:

- pickup coil rotor ①
- washer
- pickup coil rotor bolt

NOTE: _____

Align the projection ① into the pickup coil rotor with the groove ② into the crankshaft.

PICKUP COIL ROTOR

ENG

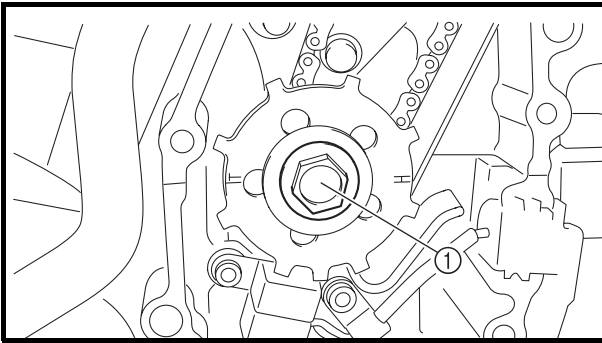

2. Tighten:

- pickup coil rotor bolt ①

 **45 Nm (4.5 m · kg)**

NOTE:

While holding the generator rotor ② with the sheave holder ③, tighten the pickup coil rotor bolt.

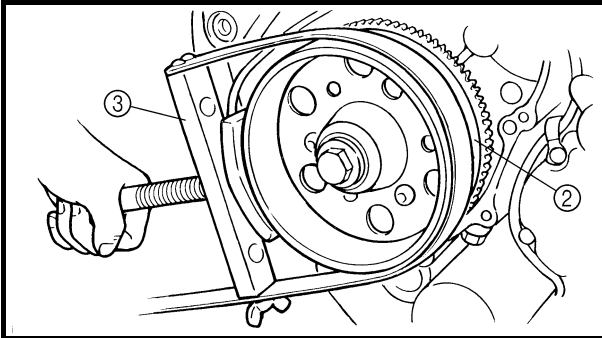

Sheave holder
90890-01701

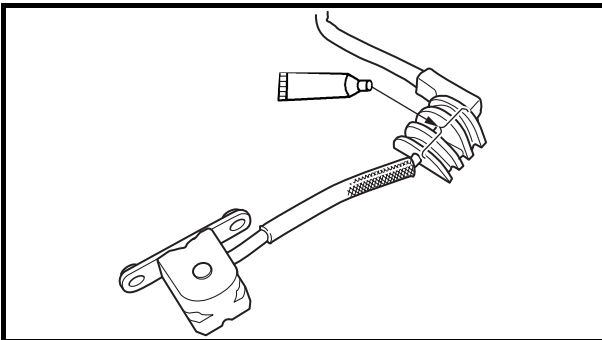

3. Apply:

- sealant
- (onto the crankshaft position sensor lead grommet)



Yamaha bond No. 1215
90890-85505

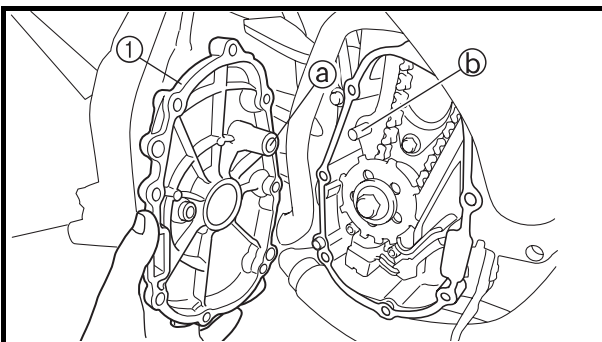

4. Install:

- pickup coil rotor cover ①

 **12 Nm (1.2 m · kg)**

NOTE:

Align the hole ① into the pickup coil rotor cover with the pin ②.



EAS00273

CLUTCH
CLUTCH COVER

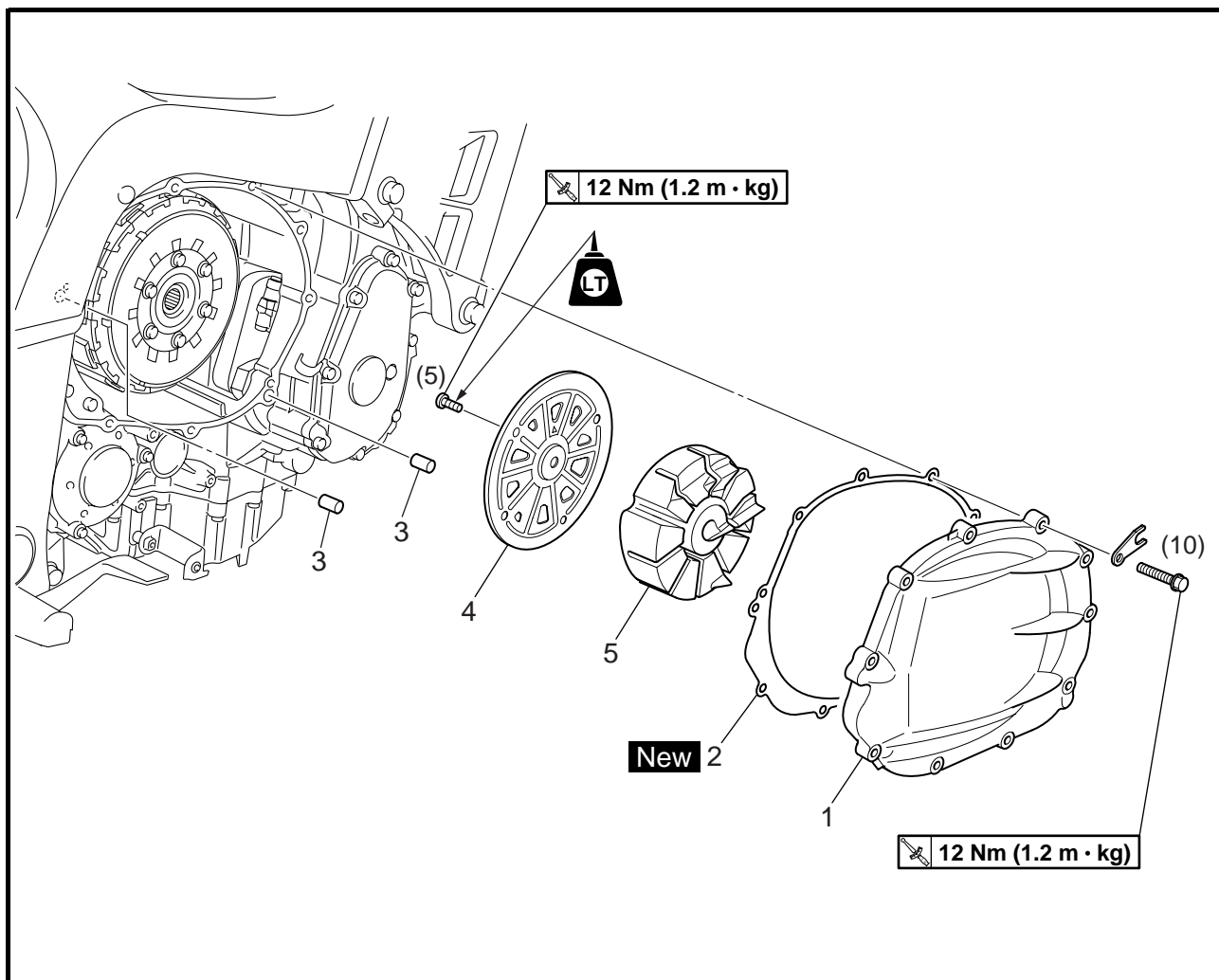

Order	Job/Part	Q'ty	Remarks
	Removing the clutch cover		Remove the parts in the order listed.
	Right side cowling		Refer to "COWLINGS AND COVERS" in chapter 3.
	Engine oil		Drain. Refer to "CHANGING THE ENGINE OIL" in chapter 3.
1	Clutch cover	1	
2	Clutch cover gasket	1	
3	Dowel pin	2	
4	Damper cover	1	
5	Damper	1	
			For installation, reverse the removal procedure.



EAS00274
CLUTCH

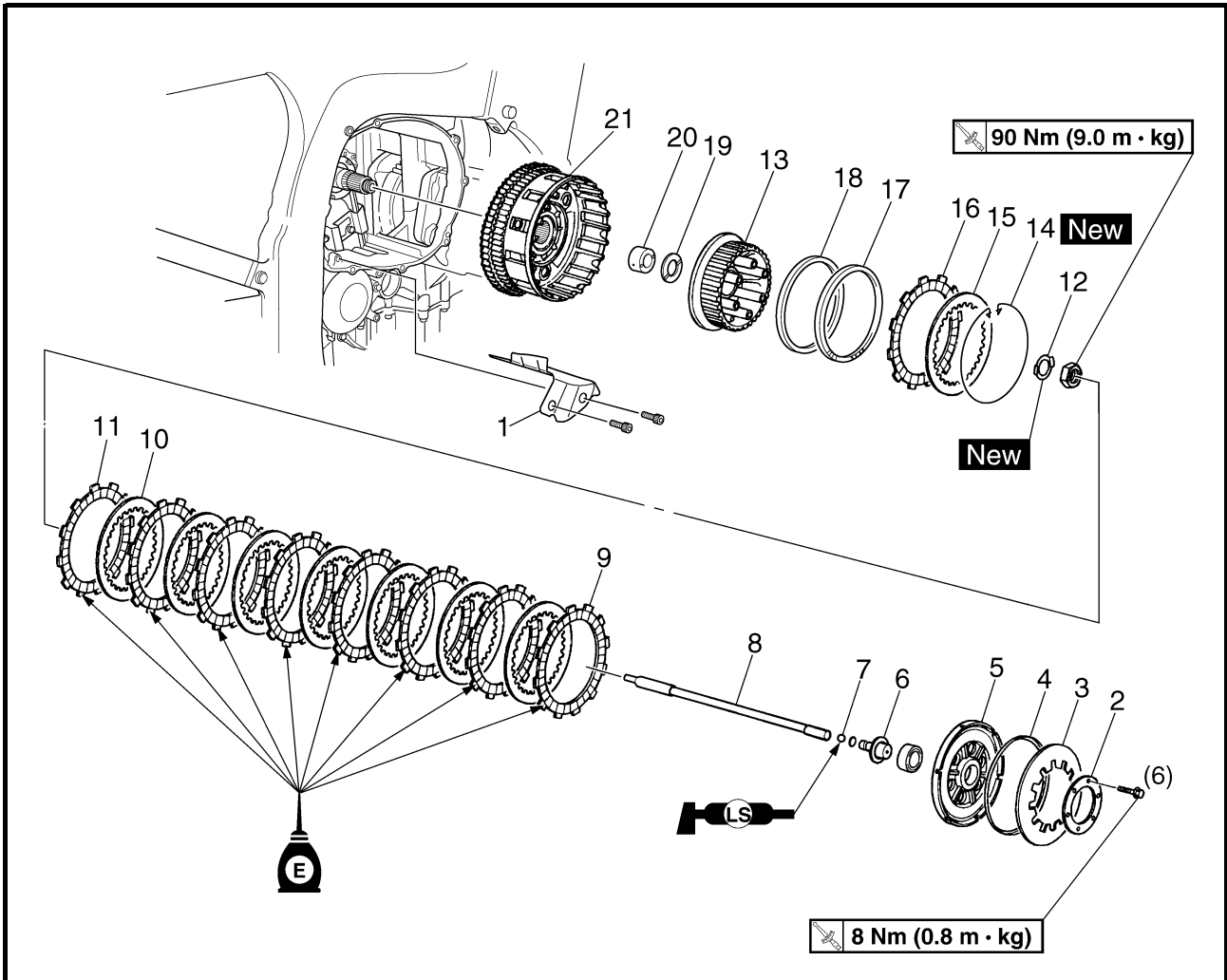

Order	Job/Part	Q'ty	Remarks
	Removing the clutch		Remove the parts in the order listed.
	Clutch release cylinder		Refer to "HYDRAULIC CLUTCH" in chapter 4.
	Rear balancer		Refer to "BALANCERS".
1	Oil guide plate	1	Refer to "REMOVING/INSTALLING THE CLUTCH".
2	Clutch spring plate retainer	1	
3	Clutch spring plate	1	
4	Clutch spring plate seat	1	
5	Pressure plate	1	
6	Short clutch push rod	1	
7	Ball	1	
8	Long clutch push rod	1	
9	Friction plate 1	1	
10	Clutch plate	7	
11	Friction plate 2	7	

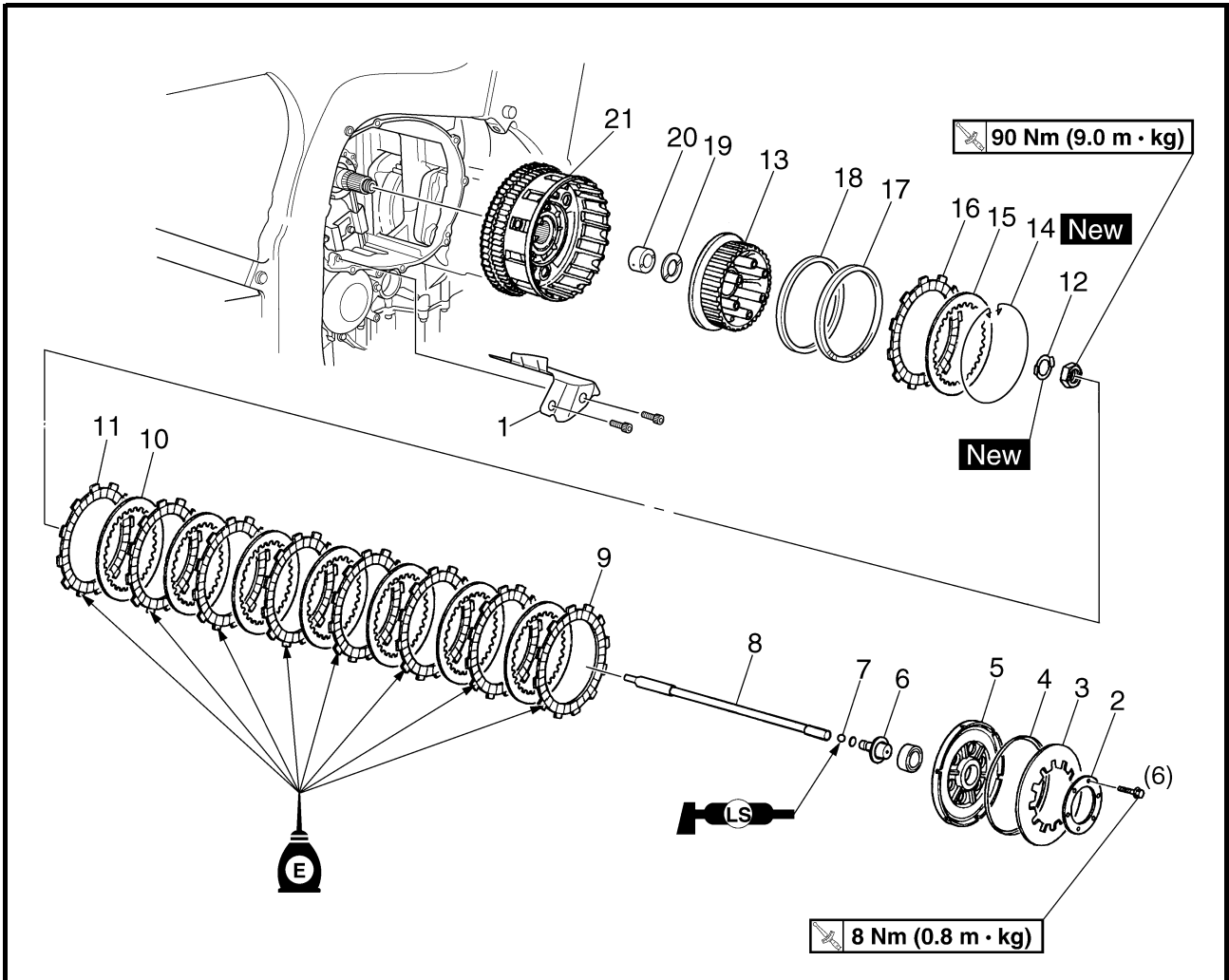

Order	Job/Part	Q'ty	Remarks
12	Lock washer	1	Refer to "REMOVING/INSTALLING THE CLUTCH".
13	Clutch boss	1	
14	Wire circlip	1	
15	Clutch plate 2	1	
16	Friction plate 3	1	
17	Clutch damper spring	1	
18	Clutch damper spring seat	1	
19	Thrust washer	1	
20	Spacer	1	
21	Clutch housing	1	
			For installation, reverse the removal procedure.

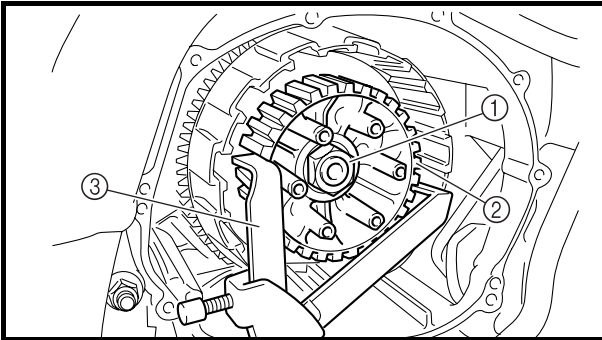
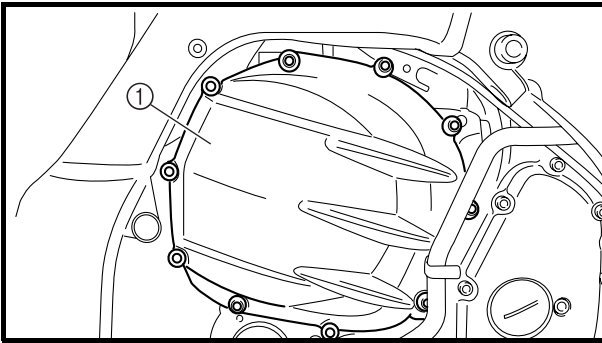

EAS00275
EAS00277

REMOVING THE CLUTCH

1. Remove:
 - rear balancer weight
Refer to "BALANCERS".
2. Remove:
 - clutch cover ①

NOTE:

Loosen each bolt 1/4 of a turn at a time, in stages and in a crisscross pattern. After all of the bolts are fully loosened, remove them.

3. Straighten the lock washer tab.
4. Loosen:
 - clutch boss nut ①

NOTE:

While holding the clutch boss ② with the universal clutch holder ③, loosen the clutch boss nut.



Universal clutch holder
90890-04086

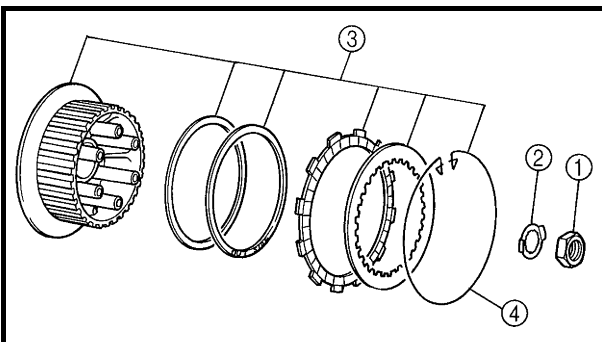

5. Remove:
 - clutch boss nut ①
 - lock washer ②
 - clutch boss assembly ③

NOTE:

There is a built-in damper between the clutch boss and the clutch plate. It is not necessary to remove the wire circlip ④ and disassemble the built-in damper unless there is serious clutch chattering.

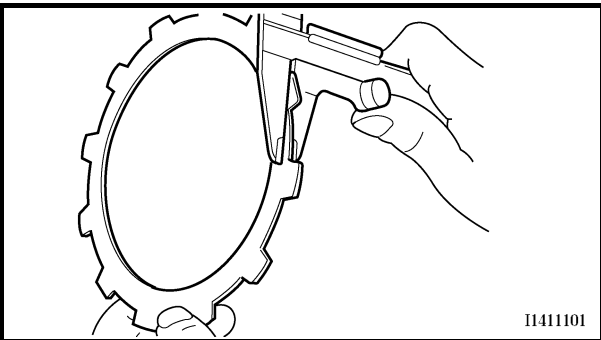
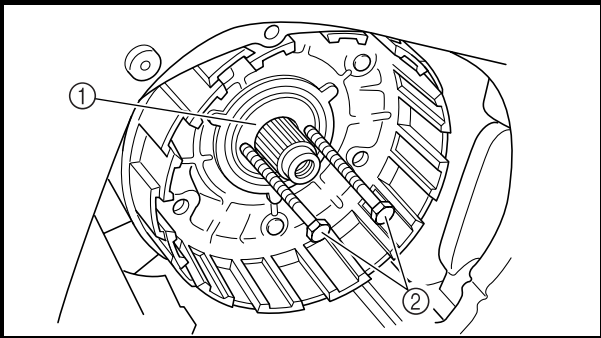
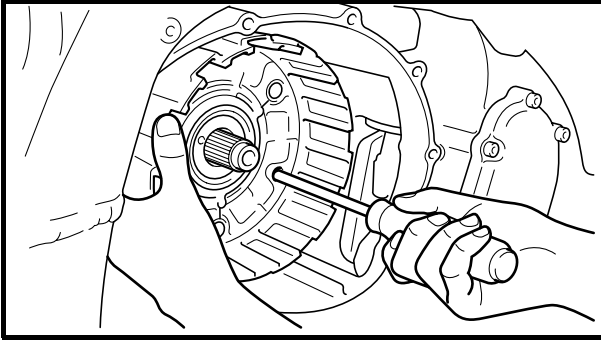

6. Remove:
- spacer ①

NOTE:

- Insert a cross-headed screwdriver into one of the holes of the clutch housing and primary driven gear, and then rotate the inner primary driven gear until both primary driver gears are aligned. The teeth of both primary driven gears must be aligned for installation.
- Insert two 5-mm bolts ② into the spacer and then remove the spacer by pulling on the bolts.

EAS00280

CHECKING THE FRICTION PLATES

The following procedure applies to all of the friction plates.

1. Check:
 - friction plate
Damage/wear → Replace the friction plates as a set.
2. Measure:
 - friction plate thickness
Out of specification → Replace the friction plates as a set.

NOTE:

Measure the friction plate at four places.



Friction plate thickness
2.9 ~ 3.1 mm
<Limit>: 2.8 mm

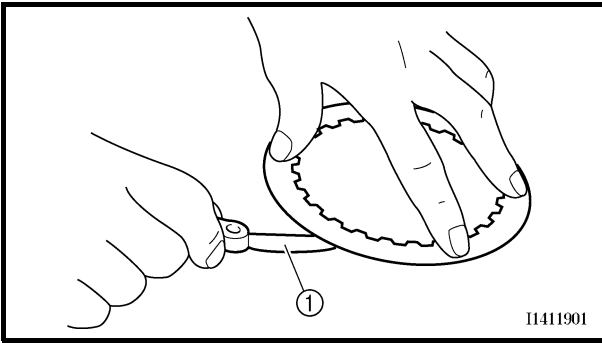

EAS00281

CHECKING THE CLUTCH PLATES

The following procedure applies to all of the clutch plates.

1. Check:
 - clutch plate
Damage → Replace the clutch plates as a set.
2. Measure:
 - clutch plate warpage
(with a surface plate and thickness gauge ①)
Out of specification → Replace the clutch plates as a set.



**Maximum clutch plate warpage
0.1 mm**

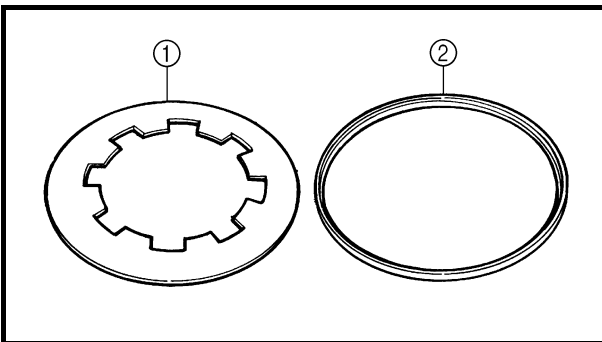

EAS00283

CHECKING THE CLUTCH SPRING PLATE

1. Check:
 - clutch spring plate ①
Damage → Replace.
2. Check:
 - clutch spring plate seat ②
Damage → Replace.

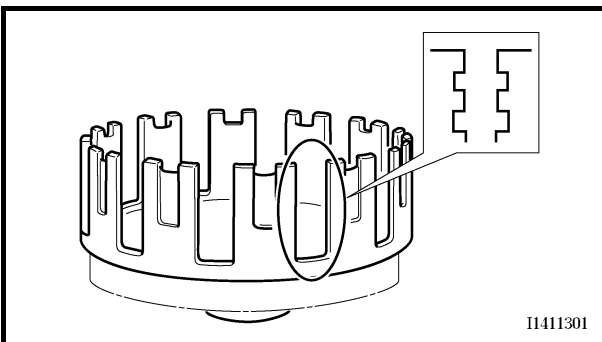

EAS00284

CHECKING THE CLUTCH HOUSING

1. Check:
 - clutch housing dogs
Damage/pitting/wear → Deburr the clutch housing dogs or replace the clutch housing.

NOTE:

Pitting on the clutch housing dogs will cause erratic clutch operation.

2. Check:
 - bearing
Damage/wear → Replace the bearing and clutch housing.

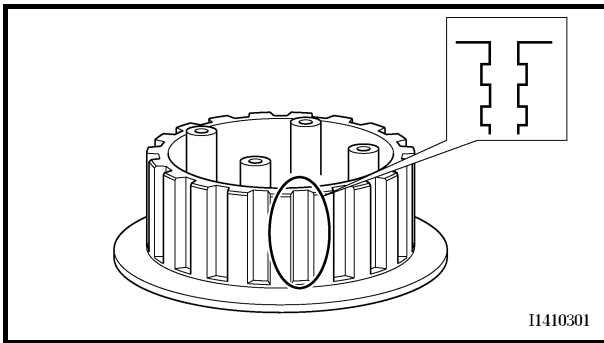

EAS00285

CHECKING THE CLUTCH BOSS

1. Check:

- clutch boss splines
Damage/pitting/wear → Replace the clutch boss.

NOTE:

Pitting on the clutch boss splines will cause erratic clutch operation.

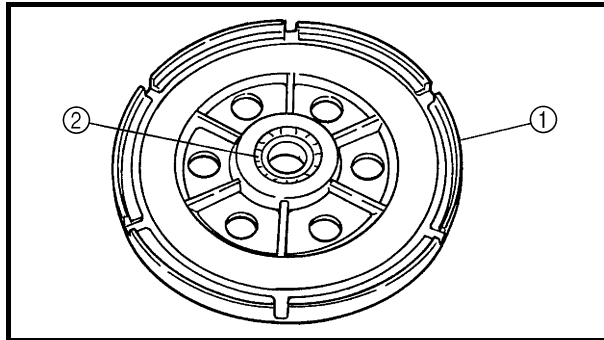

EAS00286

CHECKING THE PRESSURE PLATE

1. Check:

- pressure plate ①
Cracks/damage → Replace.
- bearing ②
Damage/wear → Replace.

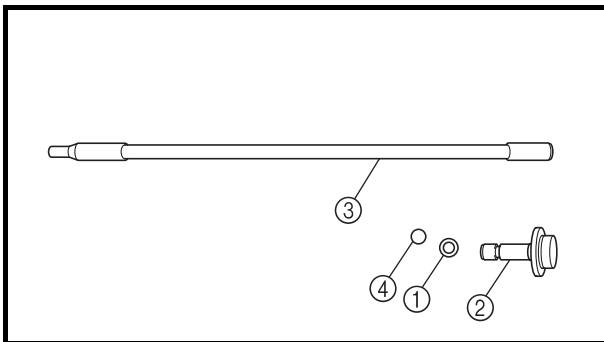

EAS00288

CHECKING THE CLUTCH PUSH RODS

1. Check:

- O-ring ①
- short clutch push rod ②
- long clutch push rod ③
- ball ④

Cracks/damage/wear → Replace the defective part(s).

2. Measure:

- long clutch push rod bending
Out of specification → Replace the long clutch push rod.



Long clutch push rod bending limit
0.37 mm

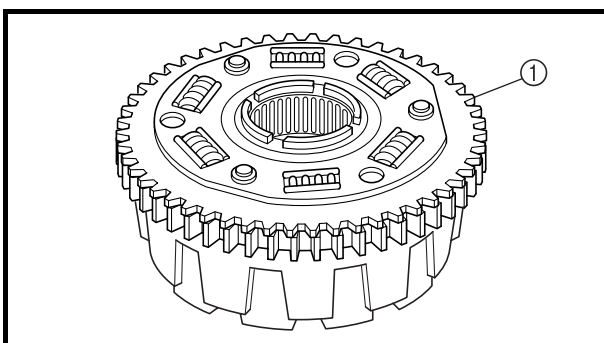

EAS00292

CHECKING THE PRIMARY DRIVEN GEAR

1. Check:

- primary driven gear ①
Damage/wear → Replace the clutch housing and crankshaft as a set.
Excessive noise during operation → Replace the clutch housing and crankshaft as a set.

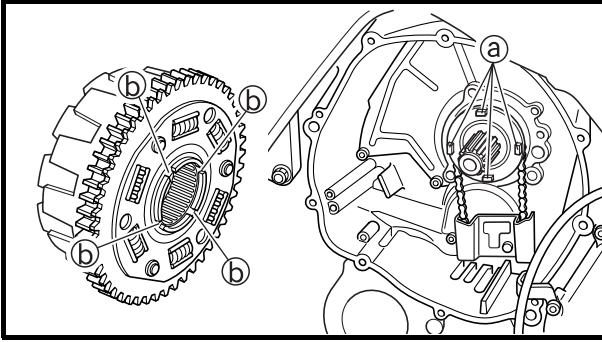

EAS00294

INSTALLING THE CLUTCH

1. Install:

- clutch housing ①

NOTE:

- Make sure that the slots ① into the clutch housing align with the tabs ② onto the oil pump drive sprocket.
- Make sure that the primary driven gear teeth and primary drive gear teeth mesh correctly.
- Insert a cross-headed screwdriver into one of the holes of the clutch housing and primary driven gear, and then rotate the inner primary driven gear until both primary driver gears are aligned. The teeth of both primary driven gears must be aligned for installation.

2. Install:

- spacer

NOTE:

Install the spacer with the two screw holes facing towards the clutch boss.

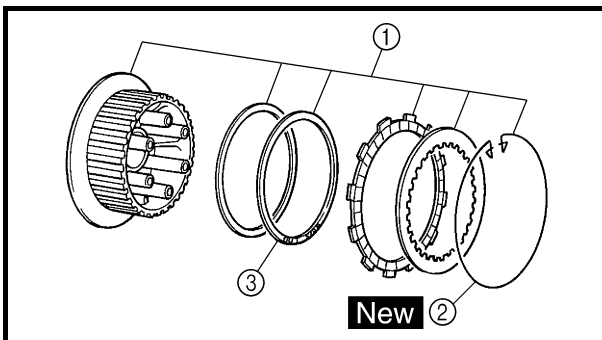

3. Install:

- clutch boss assembly ①

NOTE:

- If the wire circlip ② has been removed, carefully install a new one as shown.
- Install the clutch spring plate ③ with the "OUTSIDE" mark facing out.

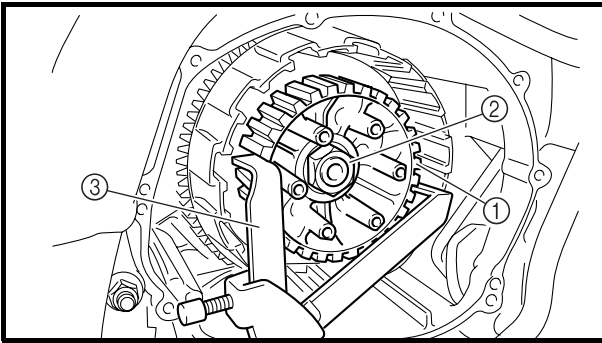

4. Install:

- thrust washer
- clutch boss ①
- lock washer **New**
- clutch boss nut ②

 **90 Nm (9.0 m · kg)**

NOTE:

While holding the clutch boss with the universal clutch holder ③, tighten the clutch boss nut.



**Universal clutch holder
90890-04086**

5. Bend the lock washer tab along a flat side of the nut.

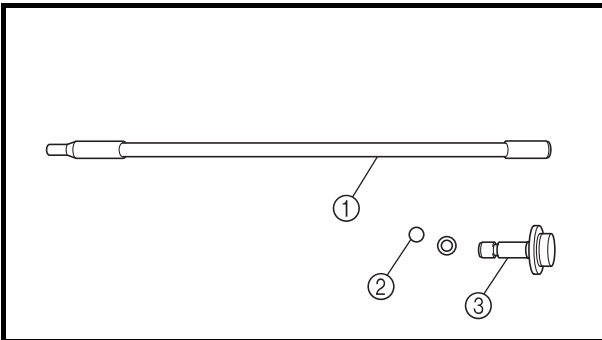

6. Lubricate:

- long clutch push rod ①
- ball ②
- short clutch push rod ③
(with the recommended lubricant)



**Recommended lubricant
Lithium soap base grease**

7. Install:

- long clutch push rod
- ball
- short clutch push rod
(along with a new O-ring)

8. Lubricate:

- friction plates
- clutch plates
(with the recommended lubricant)



**Recommended lubricant
Engine oil**



9. Install:

- friction plates
- clutch plates

NOTE:

First, install a friction plate and then alternate between a clutch plate and a friction plate.

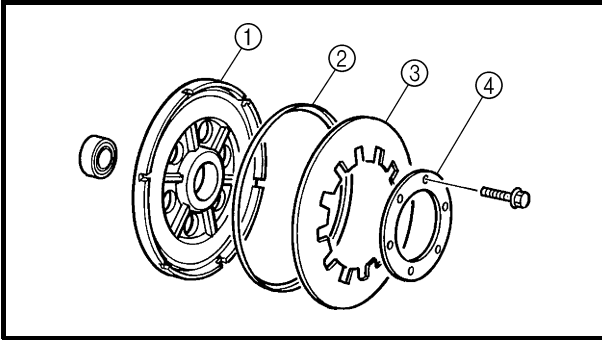

10. Install:

- pressure plate ①
- clutch spring plate seat ②
- clutch spring plate ③
- clutch spring plate retainer ④

 **8 Nm (0.8 m · kg)**

NOTE:

Tighten the clutch spring bolts in stages and in a crisscross pattern.

11. Install:

- rear balancer weight
Refer to "BALANCERS".

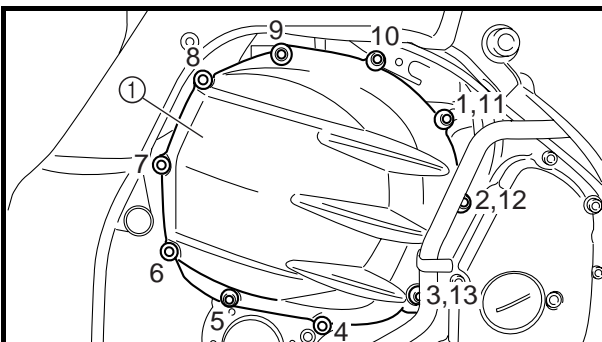

12. Install:

- clutch cover ①

 **12 Nm (1.2 m · kg)**

NOTE:

Tighten the clutch cover bolts in the proper tightening sequence as show.



EAS00326

SHIFT SHAFT

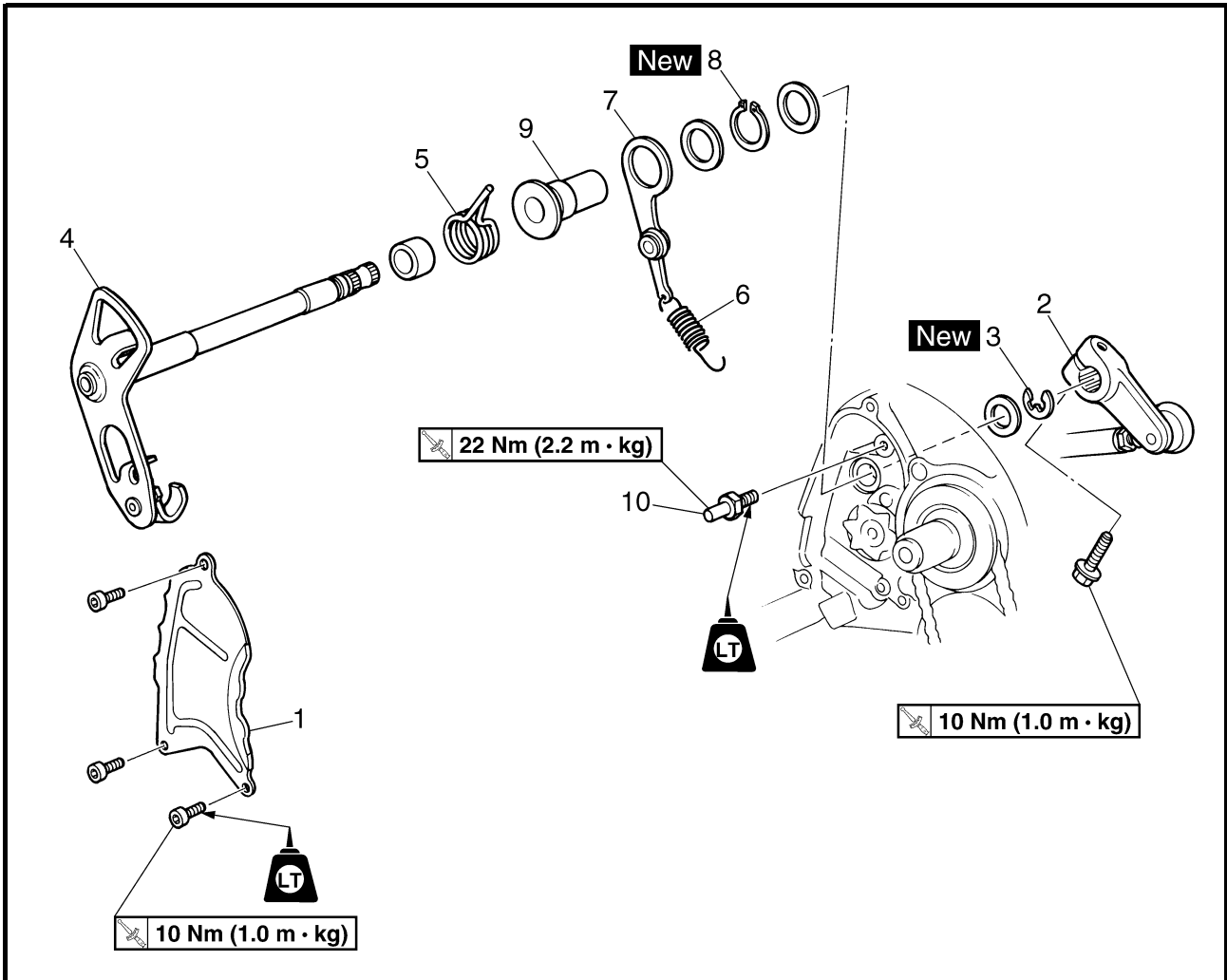

Order	Job/Part	Q'ty	Remarks
	Removing the shift shaft		Remove the parts in the order listed.
	Engine oil		Drain. Refer to "CHANGING THE ENGINE OIL" in chapter 3.
	Clutch housing		Refer to "CLUTCH".
1	Oil baffle plate	1	
2	Shift arm	1	
3	Circlip	1	
4	Shift shaft	1	Refer to "INSTALLING THE SHIFT SHAFT".
5	Shift shaft spring	1	

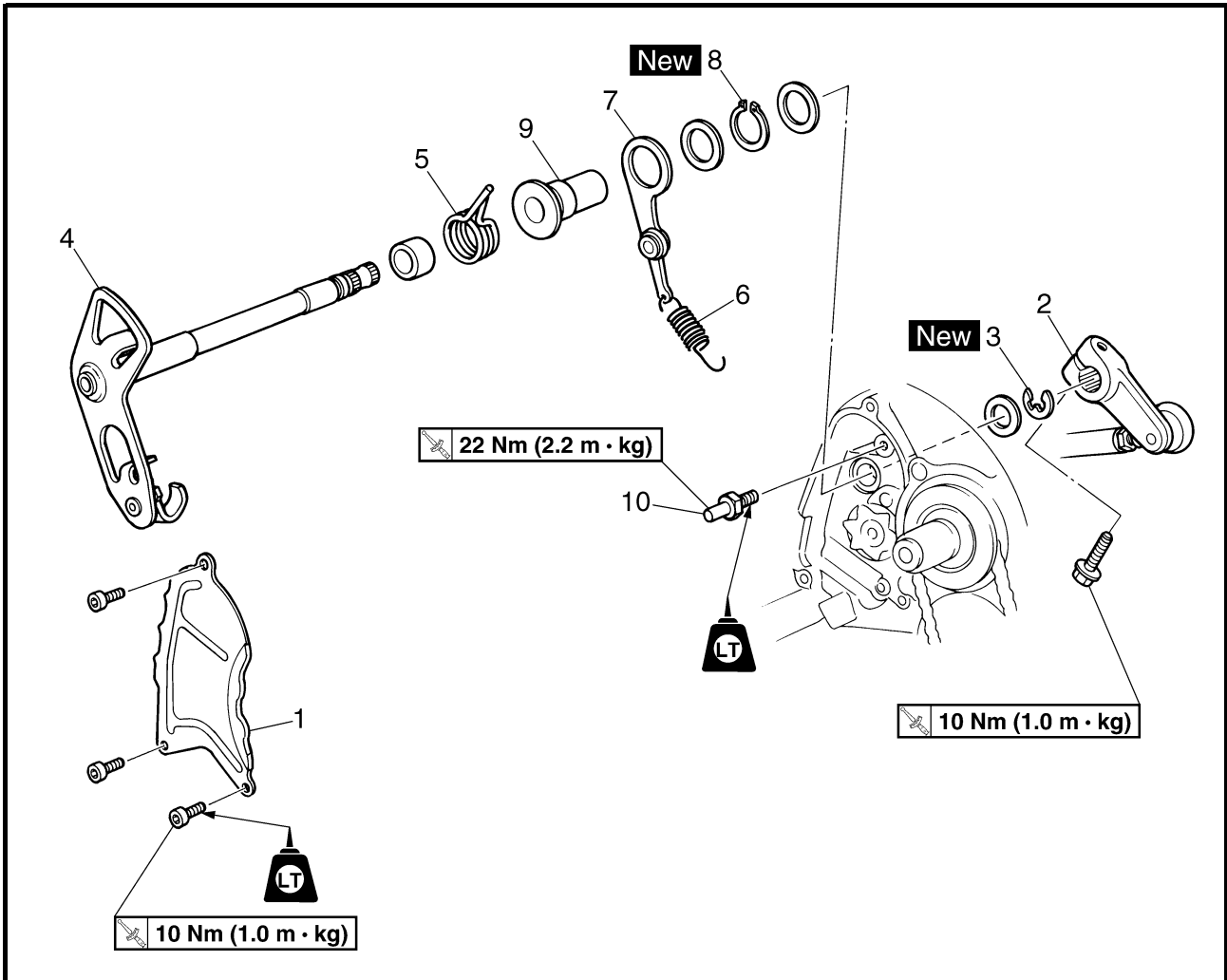

Order	Job/Part	Q'ty	Remarks
6	Stopper lever spring	1	Refer to "INSTALLING THE SHIFT SHAFT".
7	Stopper lever	1	
8	Circlip	1	
9	Collar	1	
10	Shift shaft spring stopper	1	
			For installation, reverse the removal procedure.

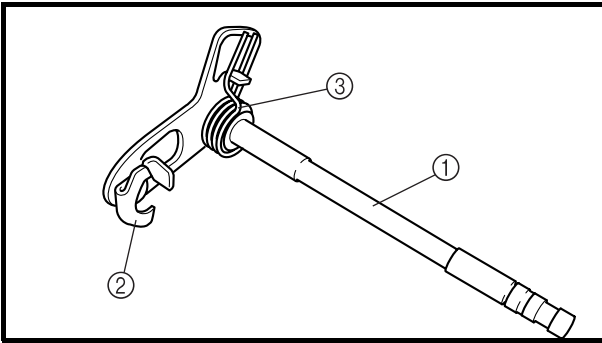

EAS00329

CHECKING THE SHIFT SHAFT

1. Check:
 - shift shaft ①
 - shift shaft pawl ②
Bends/damage/wear → Replace.
 - shift shaft spring ③
Damage/wear → Replace.

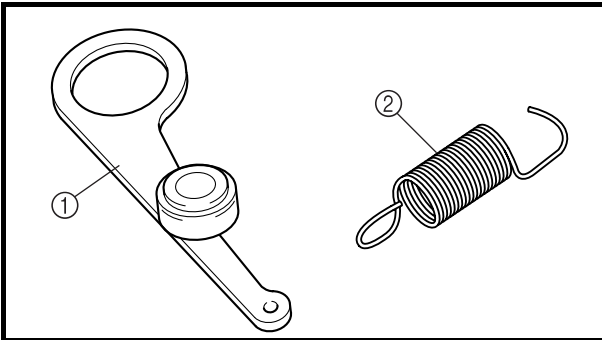

EAS00330

CHECKING THE STOPPER LEVER

1. Check:
 - stopper lever ①
Bends/damage → Replace.
 - Roller turns roughly → Replace the stopper lever.
 - stopper lever spring ②
Damage/wear → Replace.

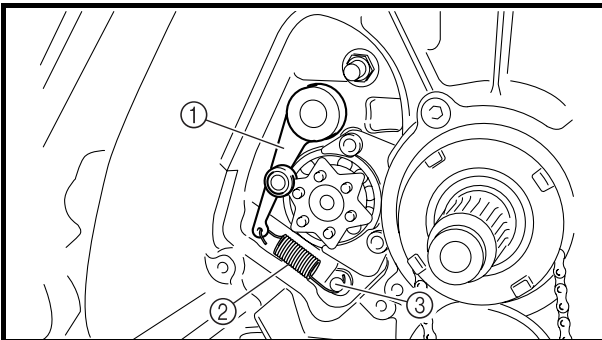

EAS00331

INSTALLING THE SHIFT SHAFT

1. Install:
 - stopper lever ①
 - stopper lever spring ②

NOTE:

- Hook the ends of the stopper lever spring onto the stopper lever and the crankcase boss ③.
- Mesh the stopper lever with the shift drum segment assembly.

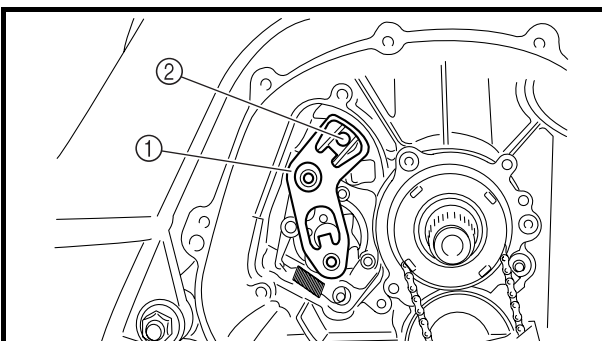

2. Install:
 - shift shaft ①

NOTE:

- Lubricate the oil seal lips with lithium soap base grease.
- Hook the end of the shift shaft spring onto the shift shaft spring stopper ②.

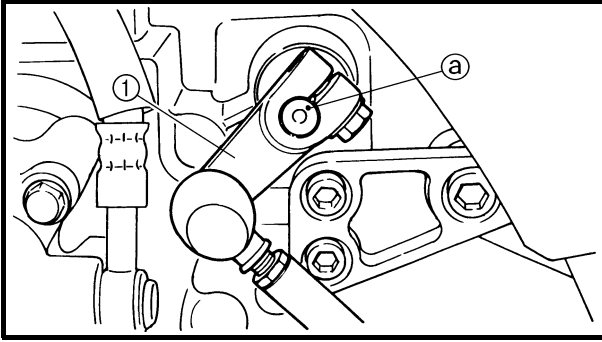

3. Install:

- shift arm ①

 10 Nm (1.0 m · kg)

NOTE:

Align the punch mark ② in the shift shaft with the slot in the shift arm.



EAS00356

OIL PAN AND OIL PUMP

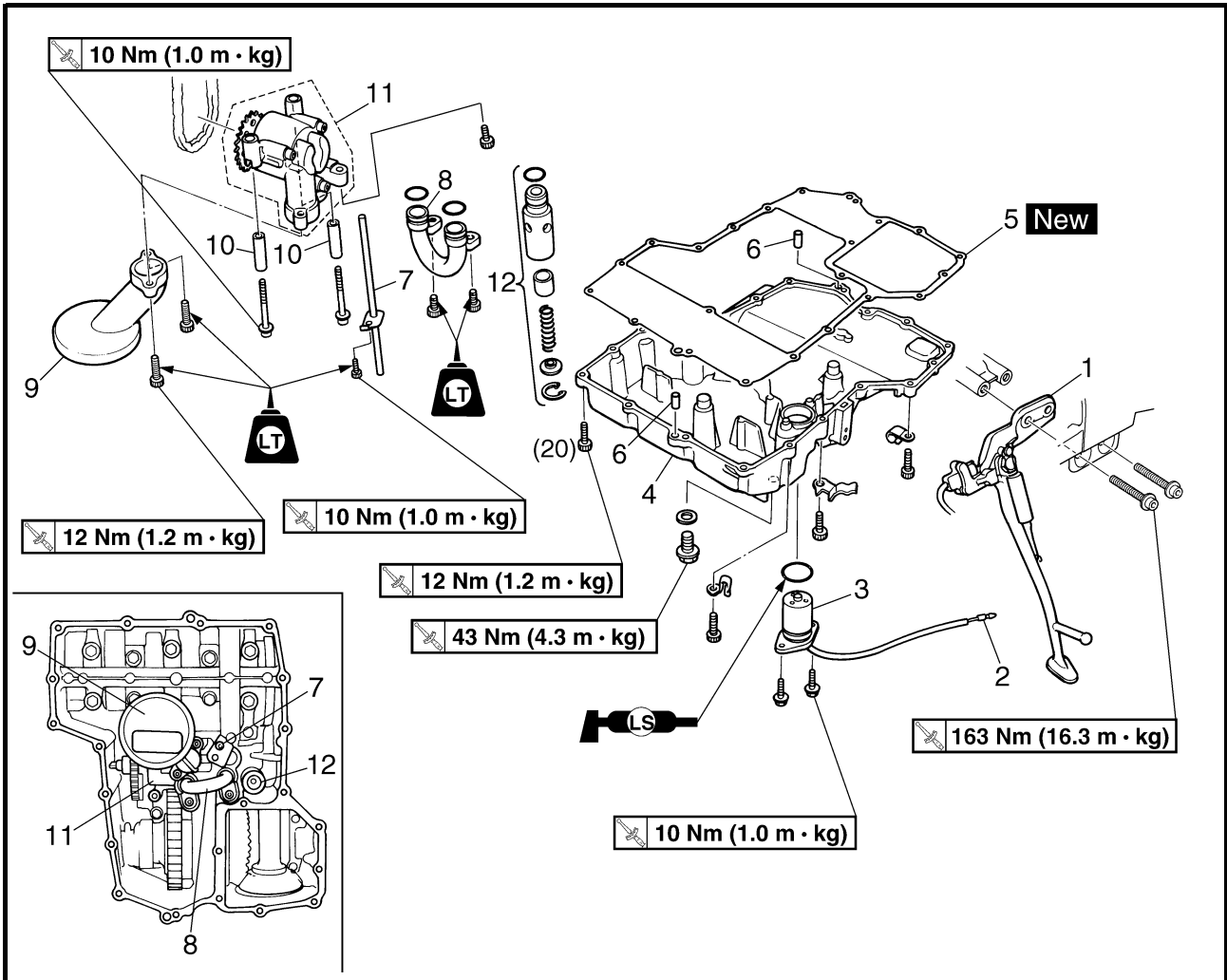

Order	Job/Part	Q'ty	Remarks
	Removing the oil pan and oil pump		Remove the parts in the order listed.
	Exhaust pipe assembly		Refer to "ENGINE".
	Air filter case		Refer to "AIR FILTER CASE" in chapter 3.
	Engine oil		Drain. Refer to "CHANGING THE ENGINE OIL" in chapter 3.
1	Sidestand	1	
2	Oil level switch connector	1	Disconnect.
3	Oil level switch	1	
4	Oil pan	1	Refer to "REMOVING/INSTALLING THE OIL PAN".
5	Oil pan gasket	1	
6	Dowel pin	2	
7	Oil delivery pipe	1	
8	Oil pipe	1	

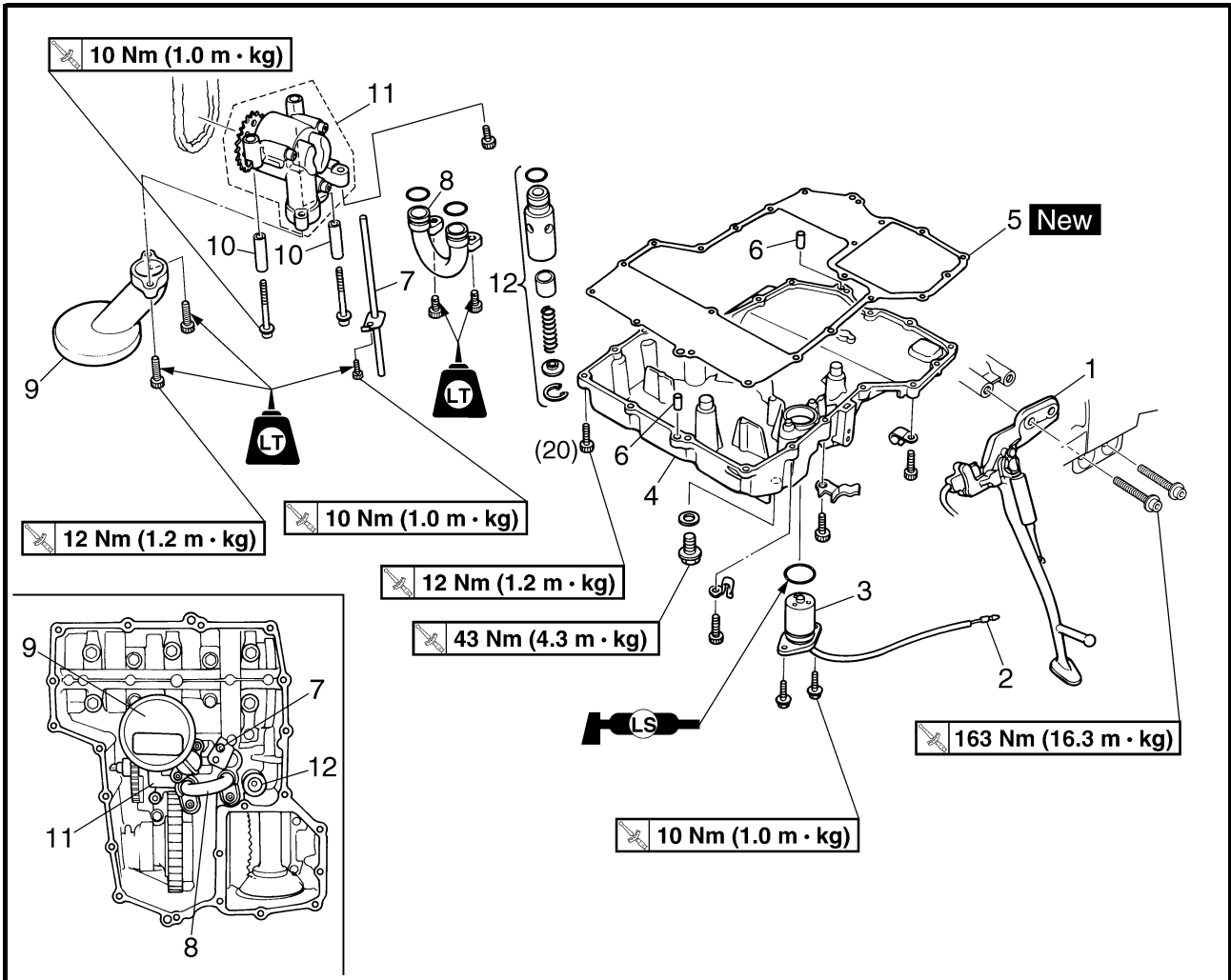

Order	Job/Part	Q'ty	Remarks
9	Oil strainer	1	Refer to "INSTALLING THE OIL STRAINER".
10	Dowel pin	2	
11	Oil pump	1	Refer to "INSTALLING THE OIL PUMP".
12	Relief valve assembly	1	
			For installation, reverse the removal procedure.



EAS00360

OIL PUMP

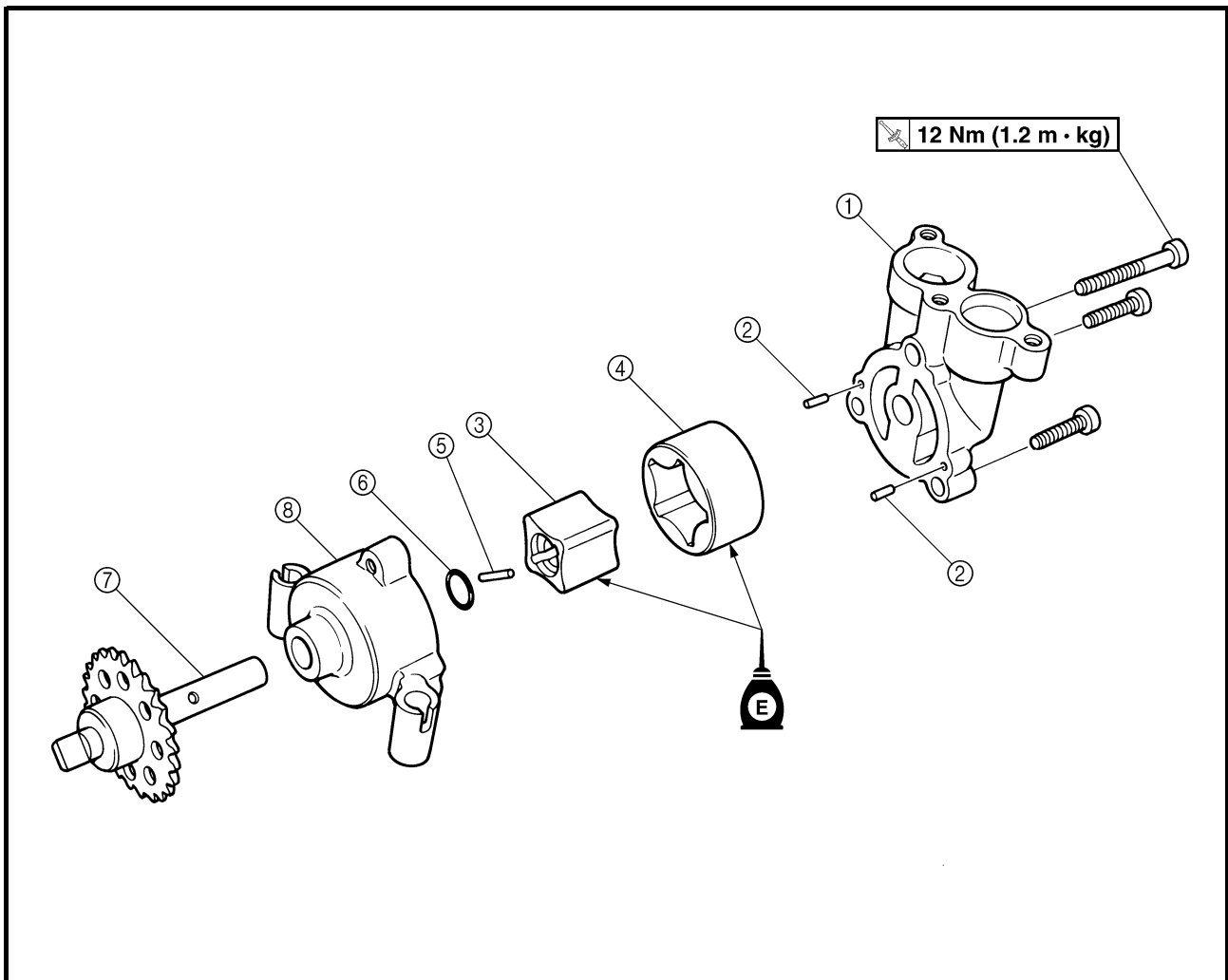

Order	Job/Part	Q'ty	Remarks
	Disassembling the oil pump		Remove the parts in the order listed.
①	Oil pump housing cover	1	
②	Pin	2	
③	Oil pump inner rotor	1	
④	Oil pump outer rotor	1	
⑤	Pin	1	
⑥	Washer	1	
⑦	Oil pump shaft	1	
⑧	Oil pump housing	1	
			For assembly, reverse the disassembly procedure.

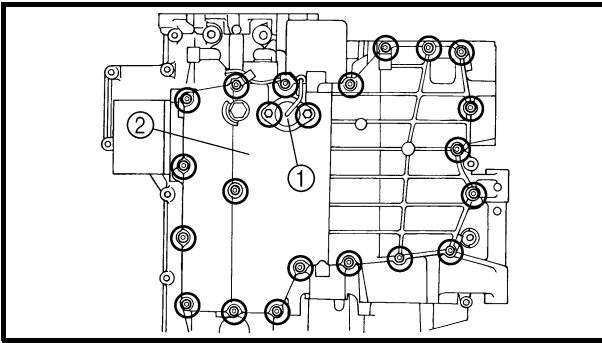

EAS00362

REMOVING THE OIL PAN

1. Remove:
 - oil level switch ①
 - oil pan ②
 - gasket
 - dowel pins

NOTE:

Loosen each bolt 1/4 of a turn at a time, in stages and in a crisscross pattern. After all of the bolts are fully loosened, remove them.

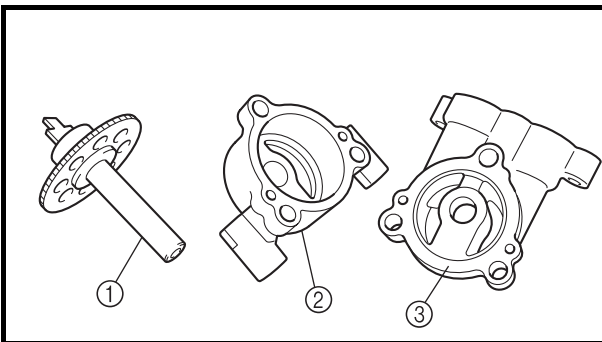

EAS00363

CHECKING THE OIL PUMP

1. Check:
 - oil pump shaft ①
 - oil pump housing ②
 - oil pump housing cover ③

Cracks/damage/wear → Replace the defective part(s).

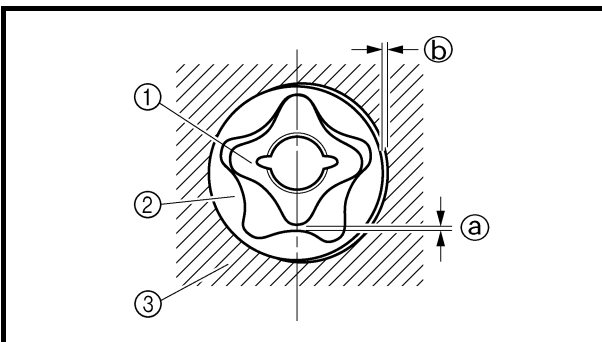

2. Measure:
 - inner-rotor-to-outer-rotor-tip clearance ①
 - outer-rotor-to-oil-pump-housing clearance ②

Out of specification → Replace the oil pump.

- ① Inner rotor
- ② Outer rotor
- ③ Oil pump housing



Inner-rotor-to-outer-rotor-tip clearance

0.09 ~ 0.15 mm

Outer-rotor-to-oil-pump-housing clearance

0.03 ~ 0.08 mm

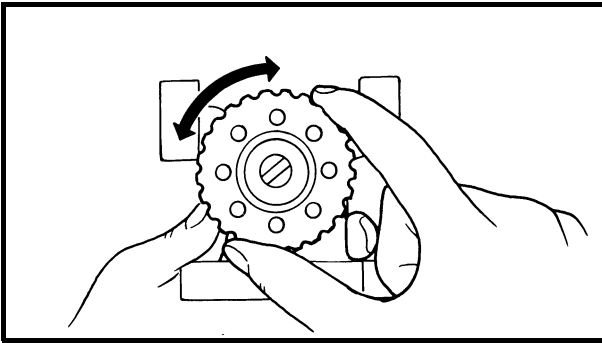

3. Check:

- oil pump operation
- Rough movement → Repeat steps (1) and (2) or replace the defective part(s).

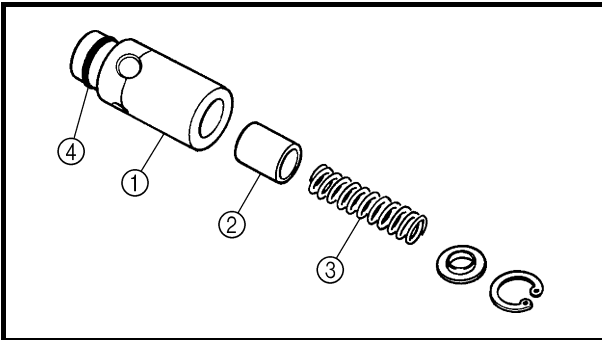

EAS00365

CHECKING THE RELIEF VALVE

1. Check:

- relief valve body ①
- relief valve ②
- spring ③
- O-ring ④

Damage/wear → Replace the defective part(s).

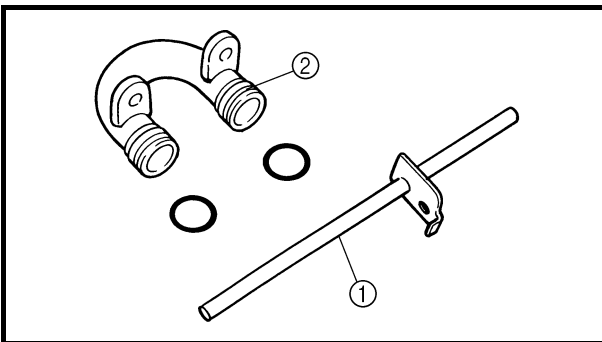

EAS00367

CHECKING THE OIL DELIVERY PIPES

The following procedure applies to all of the oil delivery pipes.

1. Check:

- oil delivery pipe ①
- oil pipe ②

Damage → Replace.

Obstruction → Wash and blow out with compressed air.

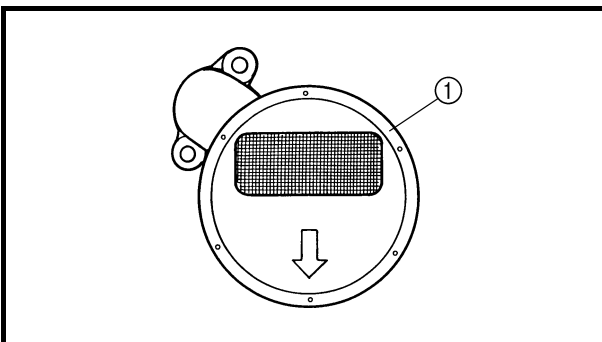

EAS00368

CHECKING THE OIL STRAINER

1. Check:

- oil strainer ①

Damage → Replace.

Contaminants → Clean with engine oil.

EAS00375

ASSEMBLING THE OIL PUMP

1. Lubricate:

- inner rotor
 - outer rotor
 - oil pump shaft
- (with the recommended lubricant)





2. Check:
 - oil pump operation
 Refer to "CHECKING THE OIL PUMP".

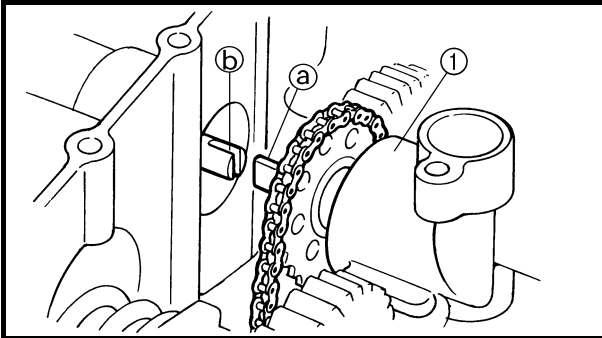

EAS00376

INSTALLING THE OIL PUMP

1. Install:

- oil pump ①  **12 Nm (1.2 m · kg)**

⚠ WARNING

Align the projection ① on the oil pump with the slit ② on the impeller shaft.

CAUTION:

After tightening the bolts, make sure the oil pump turns smoothly.

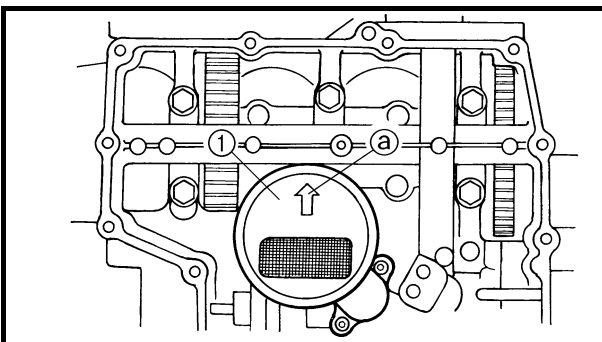

EAS00378

INSTALLING THE OIL STRAINER

1. Install:

- oil strainer ①  **10 Nm (1.0 m · kg)**

NOTE:

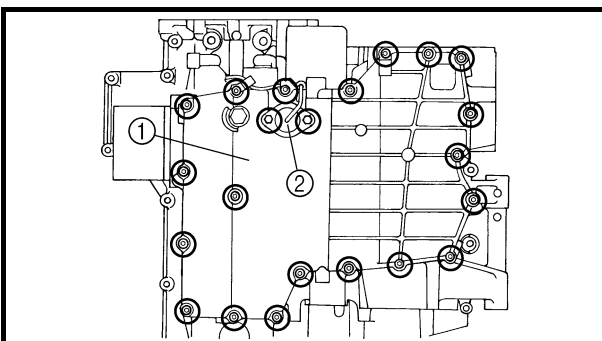

The arrow ① on the oil strainer cover must point towards the front of the engine.



EAS00380

INSTALLING THE OIL PAN

1. Install:

- dowel pins
- gasket **New**
- oil pan ①  **12 Nm (1.2 m · kg)**
- oil level switch ②  **10 Nm (1.0 m · kg)**
- engine oil drain bolt  **43 Nm (4.3 m · kg)**

**⚠ WARNING**

Always use new copper washers.

NOTE:

- Tighten the oil pan bolts in stages and in a crisscross pattern.
 - Lubricate the oil level switch O-ring with engine oil.
-



EAS00431

MIDDLE GEAR

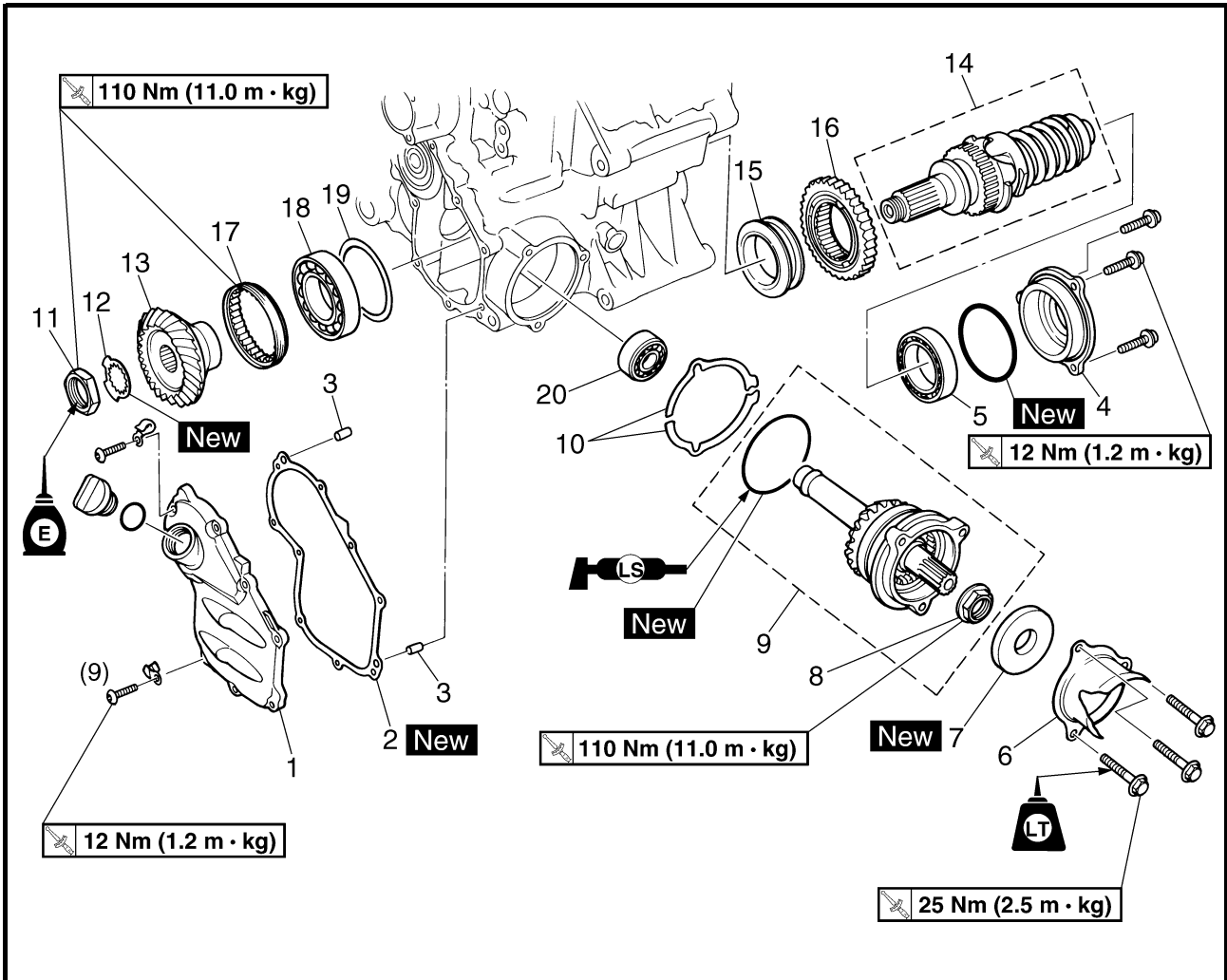

Order	Job/Part	Q'ty	Remarks
	Removing the middle gear		Remove the parts in the order listed.
	Engine		Refer to "ENGINE".
	Oil pan/oil pump		Refer to "OIL PAN AND OIL PUMP".
1	Left middle gear cover	1	
2	Left middle gear cover gasket	1	
3	Dowel pin	2	
4	Right middle gear cover	1	
5	Bearing	1	
6	Middle driven shaft end cover	1	
7	Oil seal	1	
8	Middle driven pinion gear nut	1	Loosen.
9	Middle driven shaft assembly	1	Refer to "REMOVING THE MIDDLE GEAR" and "INSTALLING THE MIDDLE DRIVEN SHAFT ASSEMBLY".
10	Middle driven shaft shim	2	

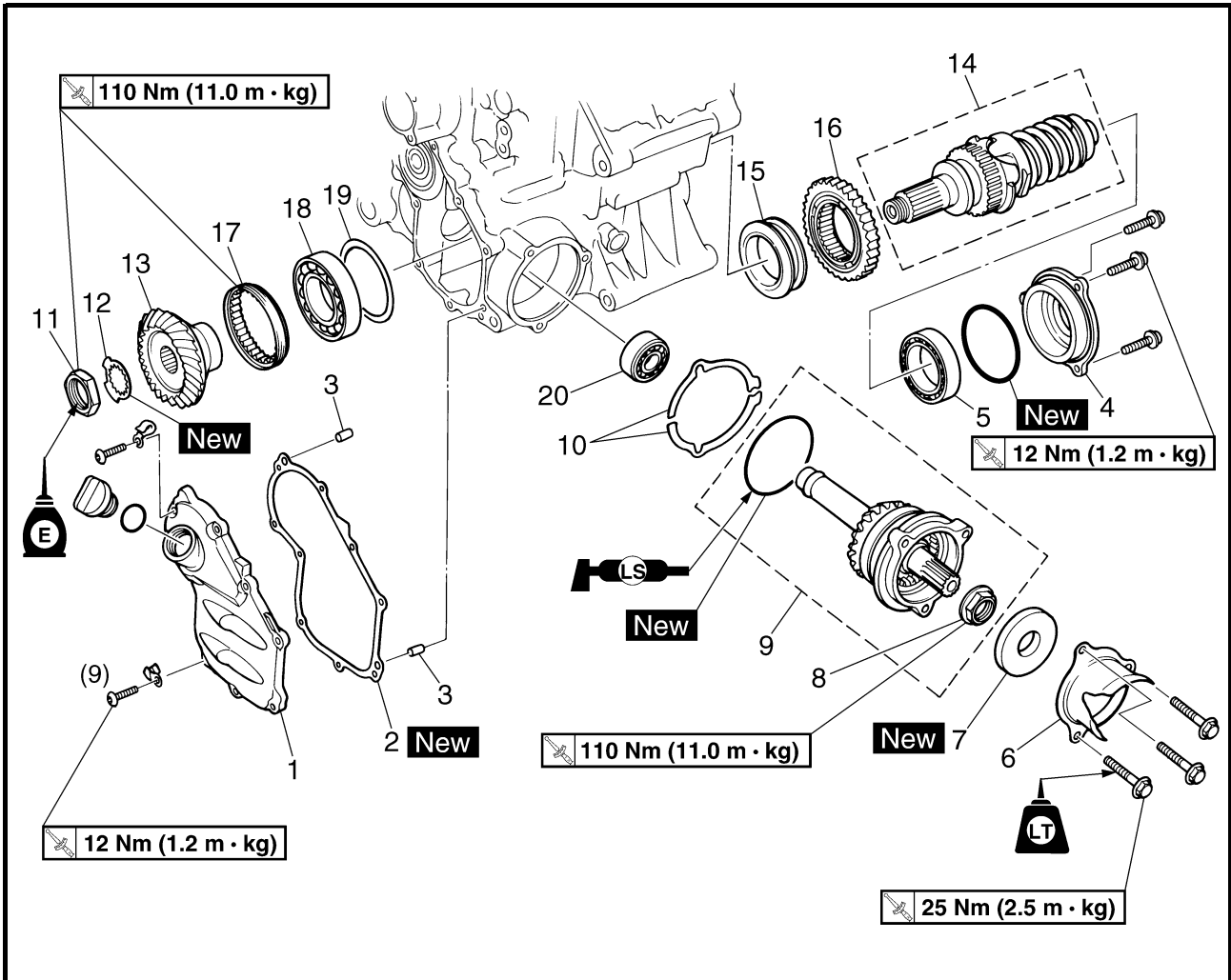

Order	Job/Part	Q'ty	Remarks
11	Middle drive pinion gear nut	1	Refer to "REMOVING THE MIDDLE GEAR" and "INSTALLING THE MIDDLE DRIVE SHAFT ASSEMBLY".
12	Lock washer	1	
13	Middle drive pinion gear	1	
14	Middle drive shaft assembly	1	
15	Spacer	1	
16	Middle driven gear	1	
17	Bearing retainer	1	
18	Bearing	1	Refer to "REMOVING THE MIDDLE GEAR" and "INSTALLING THE MIDDLE DRIVE SHAFT ASSEMBLY".
19	Middle drive shaft shim	1	
20	Bearing	1	
			For installation, reverse the removal procedure.

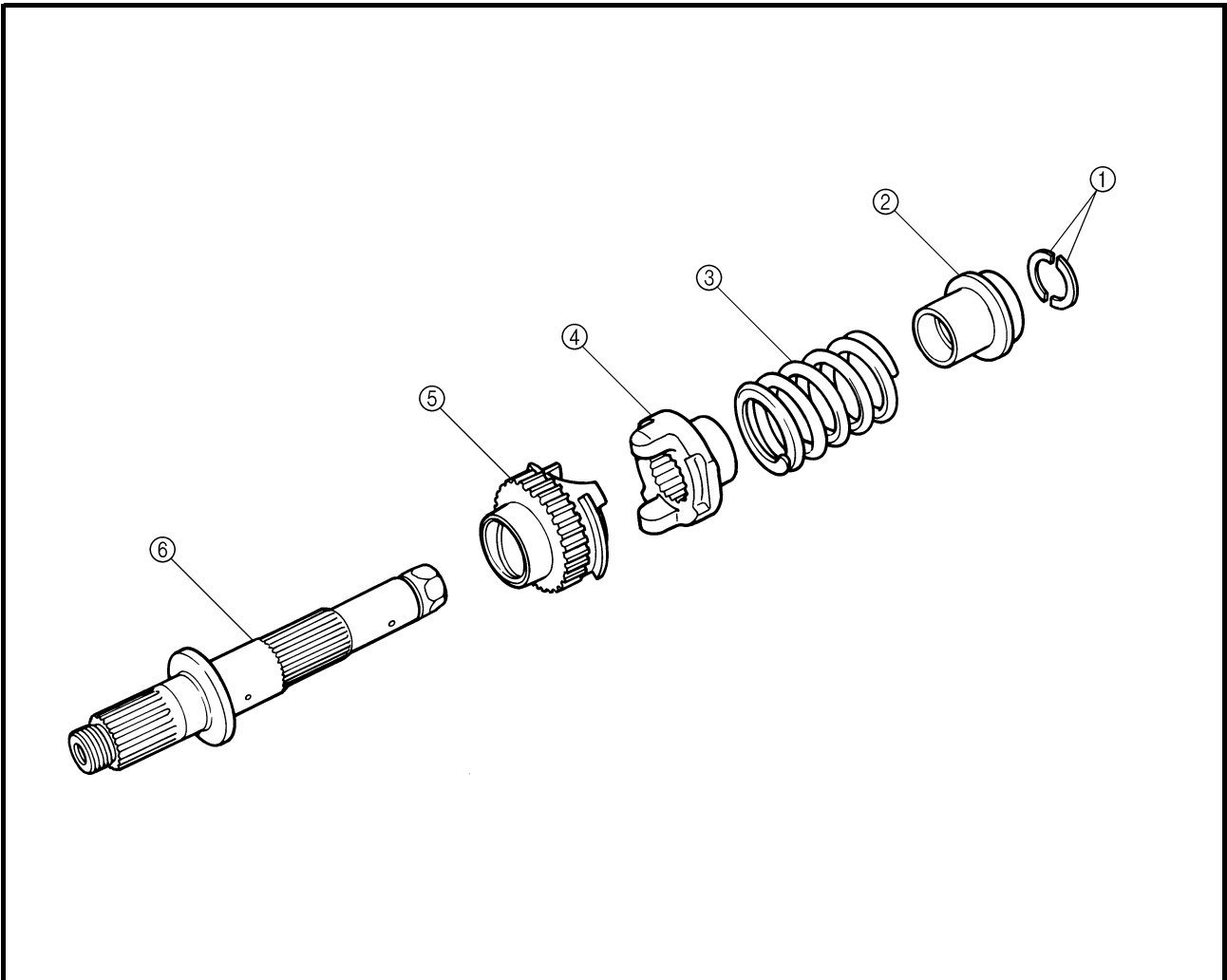

Order	Job/Part	Q'ty	Remarks
	Disassembling the middle drive shaft assembly		Remove the parts in the order listed.
①	Spring retainer	2	Refer to "DISASSEMBLING/ASSEMBLING THE MIDDLE DRIVE SHAFT ASSEMBLY".
②	Spring seat	1	
③	Damper spring	1	
④	Damper driven cam	1	
⑤	Damper drive cam	1	
⑥	Middle drive shaft	1	
			For assembly, reverse the disassembly procedure.

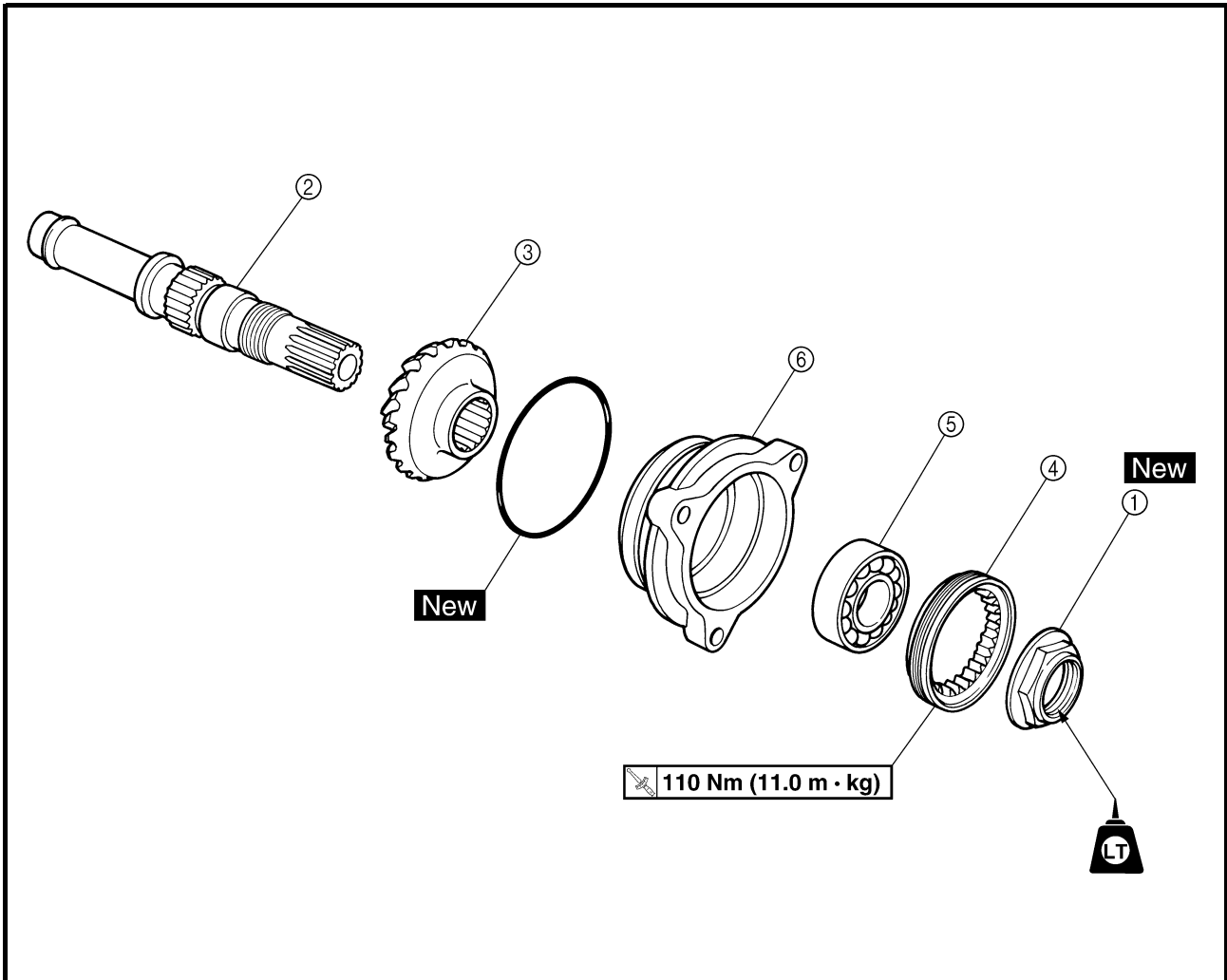

Order	Job/Part	Q'ty	Remarks
	Disassembling the middle driven shaft assembly		Remove the parts in the order listed.
①	Middle driven pinion gear nut	1	
②	Middle driven shaft	1	
③	Middle driven pinion gear	1	
④	Bearing retainer	1	Refer to "DISASSEMBLING/ASSEMBLING THE MIDDLE DRIVEN SHAFT ASSEMBLY".
⑤	Bearing	1	
⑥	Middle driven shaft bearing housing	1	For assembly, reverse the disassembly procedure.

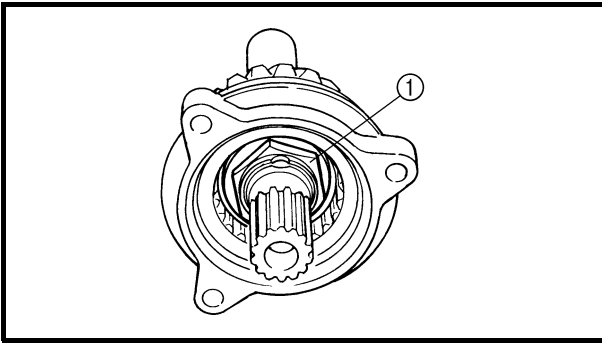

EAS00432

REMOVING THE MIDDLE GEAR

1. Straighten the punched point of the middle driven shaft nut.
2. Loosen:
 - middle driven shaft nut ①

NOTE:

While holding the middle drive shaft ②.

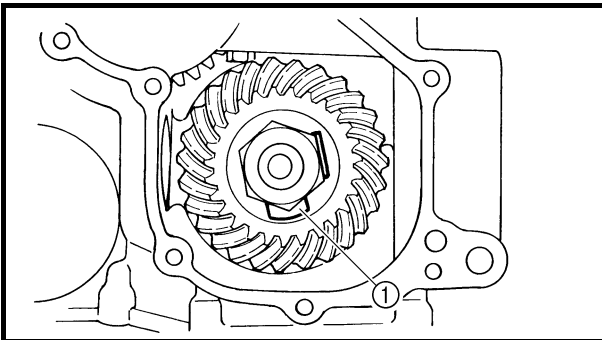
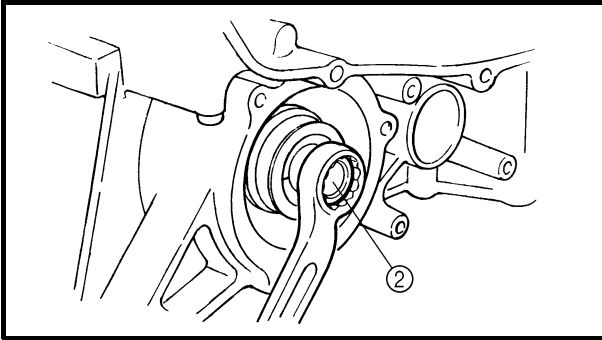

3. Straighten the lock washer tab.
4. Loosen:
 - middle drive shaft nut ①

NOTE:

While holding the middle drive shaft ②.

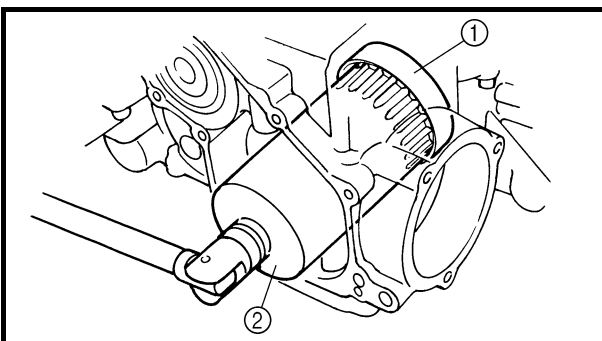
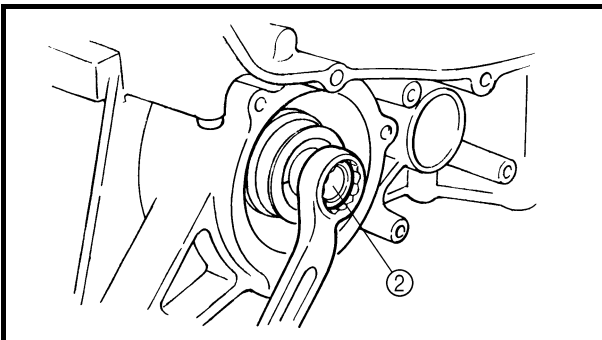

5. Straighten the punched point of the middle drive shaft bearing retainer.
6. Loosen:
 - bearing retainer ①
(with the bearing retainer wrench ②)



Bearing retainer wrench
90890-04057

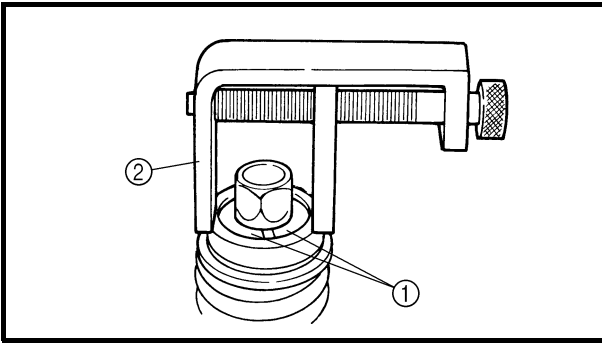

EAS00433

DISASSEMBLING THE MIDDLE DRIVE SHAFT ASSEMBLY

1. Remove:

- spring retainers ①

NOTE:

While compressing the spring with the damper spring compressor ②, remove the spring retainers.



Damper spring compressor
90890-04090

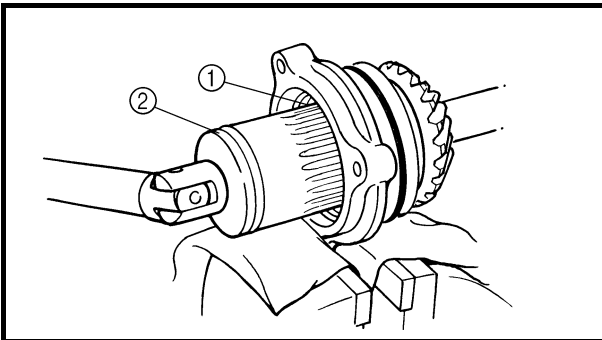

DISASSEMBLING THE MIDDLE DRIVEN SHAFT ASSEMBLY

1. Straighten the punched point of the bearing retainer.

2. Loosen:

- bearing retainer ①
(with the bearing retainer wrench ②)



Bearing retainer wrench
90890-04140

EAS00438

CHECKING THE MIDDLE DRIVE SHAFT ASSEMBLY

1. Check:

- damper cam surface
Scratches/wear → Replace the damper cam.

2. Check:

- spring
Cracks/damage → Replace.



EAS00439

CHECKING THE MIDDLE DRIVEN SHAFT ASSEMBLY

1. Check:
 - middle driven gear
Galling/pitting/wear → Replace the middle driven shaft assembly.
2. Check:
 - bearings
Damage/pitting → Replace the middle drive shaft bearing housing assembly.
3. Check:
 - O-ring
 - oil seal
Damage → Replace the defective part(s).

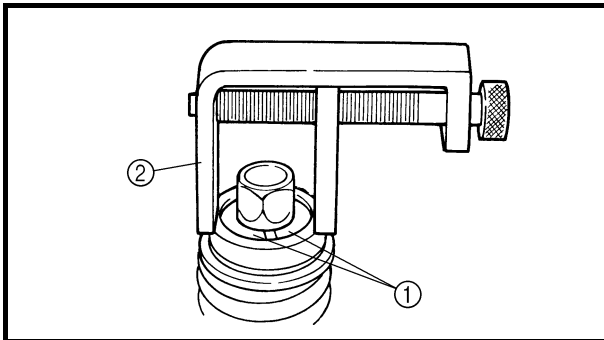

EAS00440

ASSEMBLING THE MIDDLE DRIVE SHAFT ASSEMBLY

1. Install:
 - spring retainers ①

NOTE:

While compressing the spring with the damper spring compressor ②, install the spring retainers.



Damper spring compressor
90890-04090

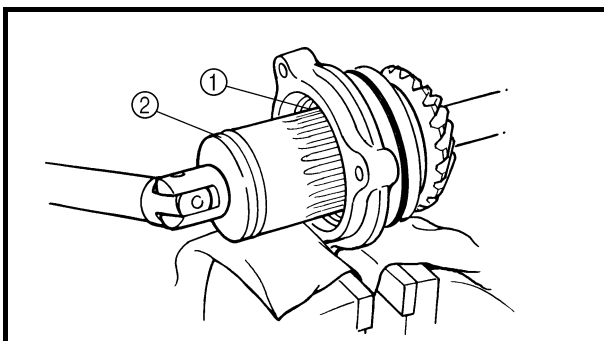

EAS00442

ASSEMBLING THE MIDDLE DRIVEN SHAFT ASSEMBLY

1. Tighten:
 - bearing retainer ①

 **110 Nm (11.0 m · kg)**

(with the bearing retainer wrench ②)



Bearing retainer wrench
90890-04140

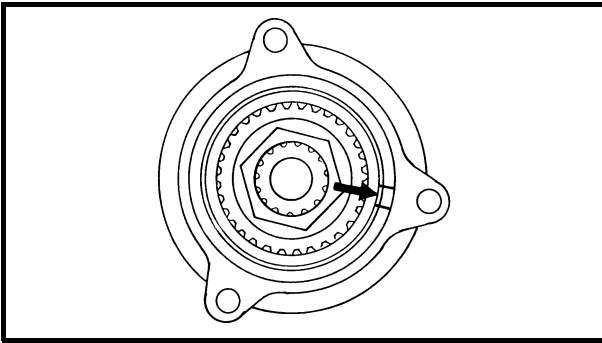

NOTE:

Lock the threads on the bearing retainer by staking them with a center punch.

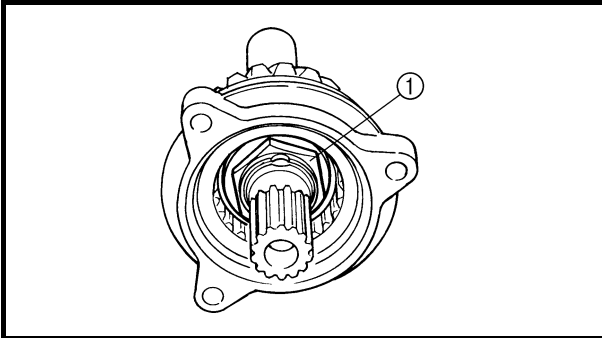

2. Install:

- middle driven shaft nut ①

NOTE:

Temporarily tighten the middle driven shaft nut.

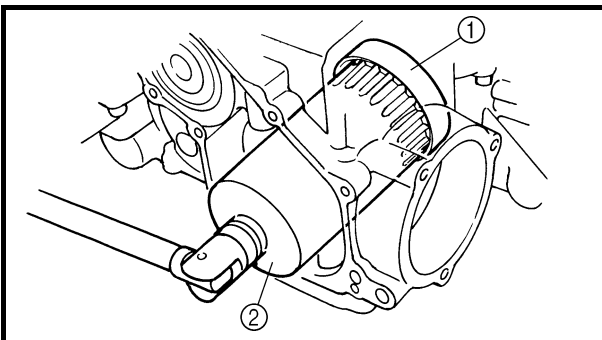

INSTALLING THE MIDDLE DRIVE SHAFT ASSEMBLY

1. Install:

- middle drive shaft shim
- bearing
- bearing retainer ①

110 Nm (11.0 m · kg)

(with the bearing retainer wrench ②)



**Bearing retainer wrench
90890-04057**

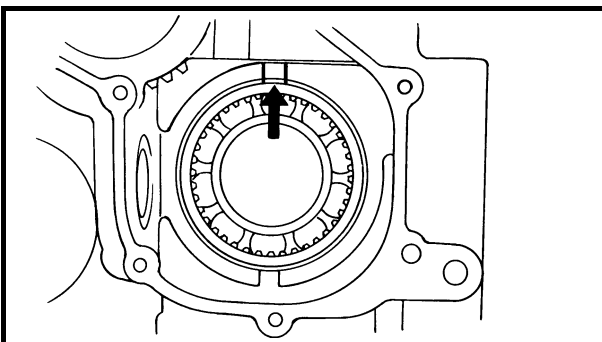

NOTE:

Lock the threads on the bearing retainer by staking them with a center punch.

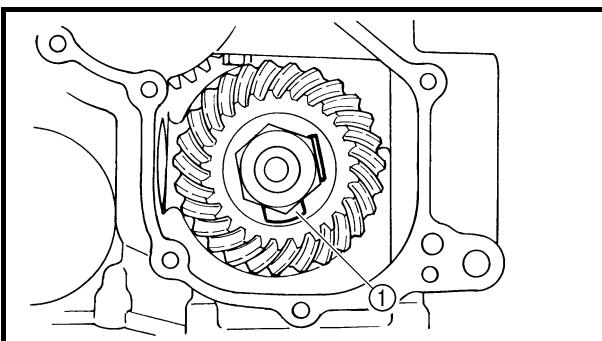

2. Install:

- middle drive pinion gear
- lock washer **New**
- middle drive pinion gear nut ①

110 Nm (11.0 m · kg)

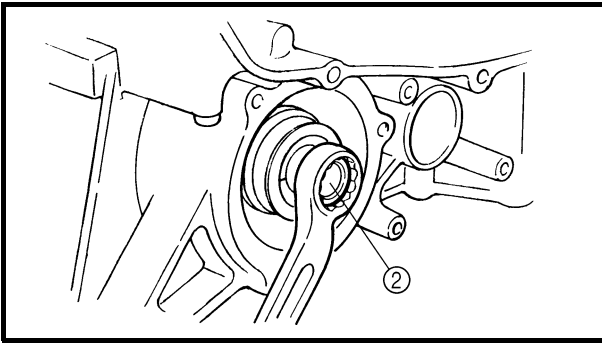

NOTE: _____
While holding the middle drive shaft ②.

3. Bend the lock washer tab along a flat side of the nut.

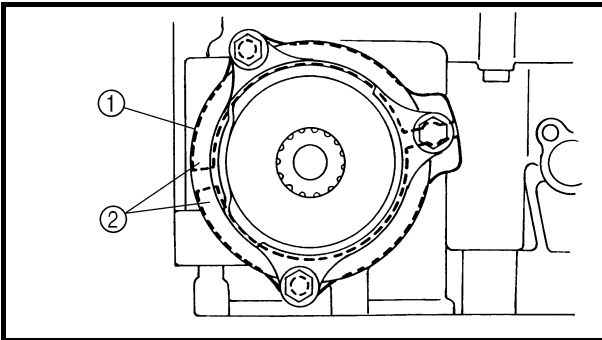

INSTALLING THE MIDDLE DRIVEN SHAFT ASSEMBLY

1. Install:
 - middle driven shaft assembly ①
 - middle driven shaft shims ②
 - middle driven shaft bearing housing bolts

NOTE: _____
Finger tighten the middle driven shaft housing bolts.

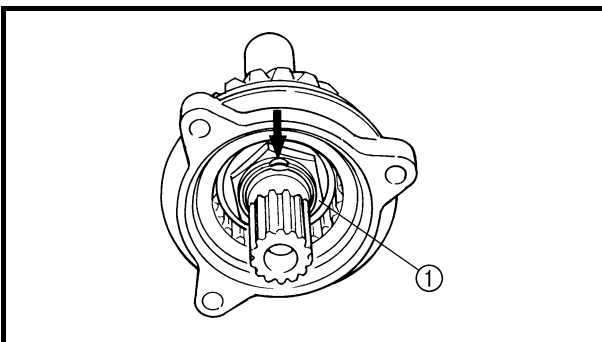

2. Tighten:
 - middle driven shaft nut ①

110 Nm (11.0 m · kg)

NOTE: _____
• While holding the middle drive shaft ②.
• Lock the threads on the middle driven shaft nut by staking them with a center punch.

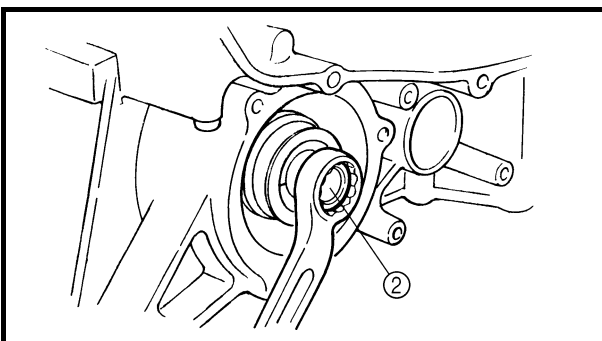



-
- d. While gently turning the middle driven shaft back and forth, measure the middle gear backlash.

NOTE: _____

Measure the middle gear backlash at four positions. Rotate the middle driven shaft 90° each time and observe the reading on the dial gauge.



EAS00450

ADJUSTING THE MIDDLE GEAR BACKLASH

- 1. Loosen:
 - middle driven shaft bearing housing bolts
- 2. Remove:
 - shim(s)

- 3. Tighten:
 - middle driven shaft bearing housing bolts

CAUTION: _____

Do not overtighten the middle driven shaft bearing housing bolts or you may obtain too little middle gear backlash and damage the middle gears. If the bolts are overtightened, loosen them until the crankcase-to-middle-driven-shaft-bearing-housing clearance is within specification, as stated below. Then, repeat all of the previous steps.

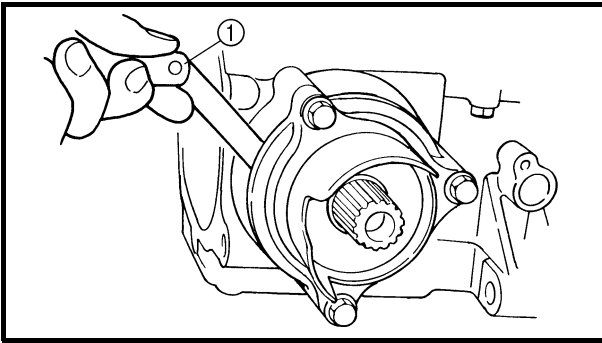
**NOTE:**

- Tighten the middle driven shaft bearing housing bolts carefully, one thread turn at a time only. Push in the middle driven shaft bearing housing and then tighten the bolts to specification.
- Clearance between the crankcase and the middle driven shaft bearing housing should be approximately 2 mm, when measured with a thickness gauge ①.

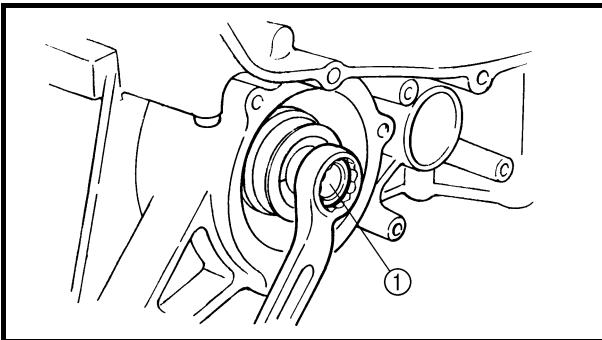

4. Hold the middle drive shaft ①.

5. Turn:

- middle driven shaft

NOTE:

While carefully tightening the middle driven shaft bearing housing bolts in stages and in a crisscross pattern, turn the middle driven shaft back and forth until the dial gauge reads 0.10 ~ 0.20 mm.

6. Measure:

- crankcase-to-middle-driven-shaft-bearing-housing clearance
(with a thickness gauge)



EAS00452

ALIGNING THE MIDDLE GEAR

NOTE:

Aligning the middle gear is necessary when any of the following parts are replaced:

- Crankcase
- Middle drive shaft
- Middle driven shaft bearing housing

1. Select:

- middle drive shaft shim(s) ①
- middle driven shaft shim(s) ②

NOTE:

Select the middle driven shaft shim(s) ② by calculating the middle drive shaft shim thickness and then measuring the middle gear backlash.

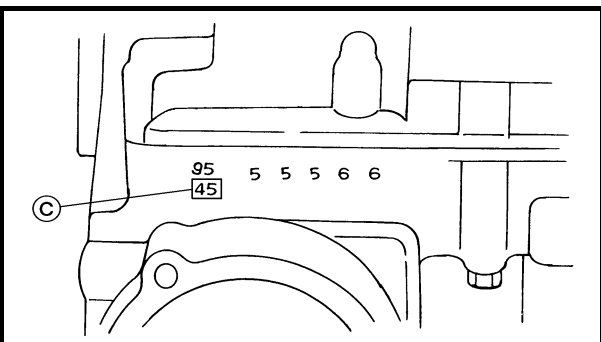
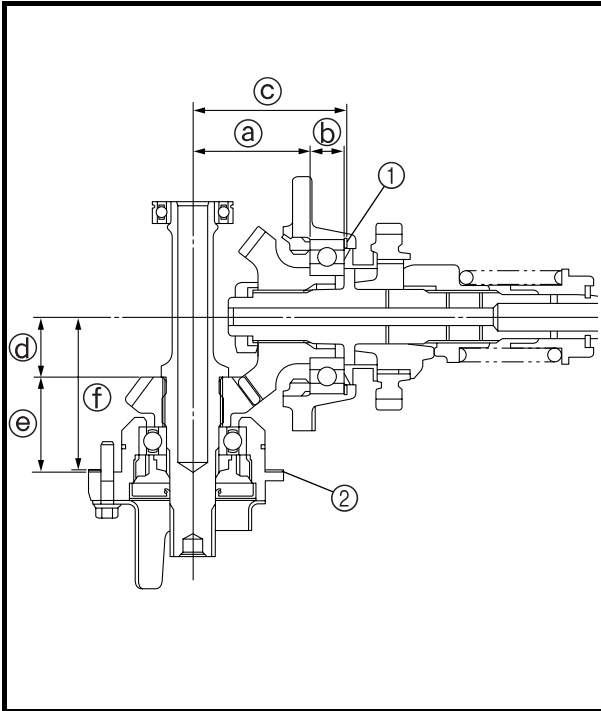

a. Position the middle gear with the appropriate shim(s) ① and ② that has had its respective thickness calculated from information marked on the crankcase and the end of the middle drive gear.

- ① Middle drive gear shim thickness “A”
- ② Middle drive gear shim thickness “B”

b. To find middle drive shaft shim thickness “A”, use the following formula.

Middle drive shaft shim thickness
“A” = c - a - b

- a = “65.00”
- b = bearing thickness constant
- c = a numeral on the upper crankcase near the main bearing selection numbers and which is added to the nominal size “84”

Example:

a is 65.00
 b is 18.94
 If the upper crankcase is marked “45”
 c is 84.45 (i.e., 84.00 + 0.45 = 84.45)
 “A” = 84.45 - 65.00 - 18.94 = 0.51
 Round off to the hundredths digit and select the appropriate shim(s).



NOTE:

In the above example, the calculated number is 0.51. The chart instructs you to round off the 1 to 0. Thus, the shim thickness is 0.50 mm.

Hundredth	Rounded value
0, 1, 2	0
3, 4, 5, 6, 7	5
8, 9	10

Shims are supplied in the following thicknesses.

Middle drive shaft shim	
Thickness (mm)	0.10 0.15 0.30 0.40 0.50 0.60

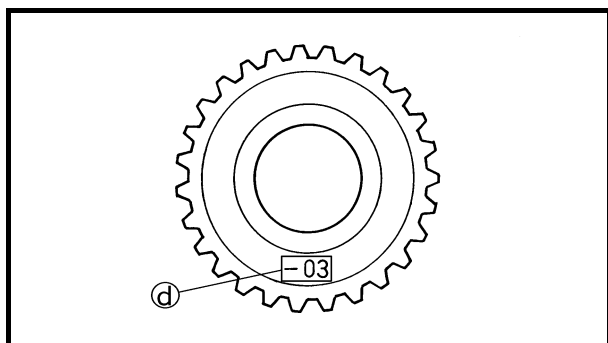

c. To find middle driven shaft shim thickness “B”, use the following formula.

<p>Middle driven shaft shim thickness “B” = d + e - f</p>
--

- ⓓ = a numeral on the middle driven pinion gear which is added to the nominal size “34”
- ⓔ = Measured value
- ⓕ = a numeral on the upper crankcase near the main bearing selection numbers and which is added to the nominal size “88”

Example:

If the middle driven pinion gear is marked “- 03”

ⓓ is 33.97 (i.e., 34.00 + (- 0.03) = 33.97)

ⓔ is 54.49

If the upper crankcase is marked “95”

ⓕ is 87.95 (i.e., 87.00 + 0.95 = 87.95)

“B” = 33.97 + 54.49 - 87.95 = 0.51

Round off to the hundredths digit and select the appropriate shim(s).

NOTE:

In the above example, the calculated number is 0.51. The chart instructs you to round off the 1 to 0. Thus, the shim thickness is 0.50 mm.

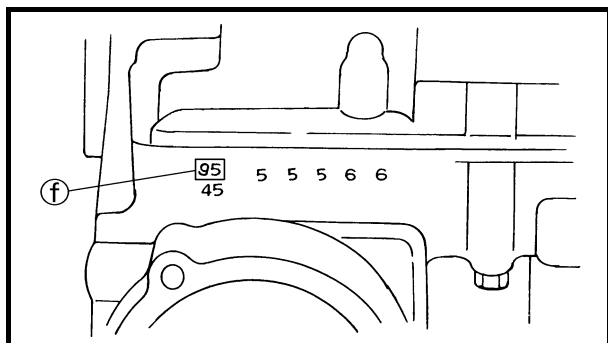

Hundredth	Rounded value
0, 1, 2	0
3, 4, 5, 6, 7	5
8, 9	10

Shims are supplied in the following thicknesses.

	Middle drive shaft shim
Thickness (mm)	0.10 0.15 0.30 0.40 0.50 0.60





CRANKCASE

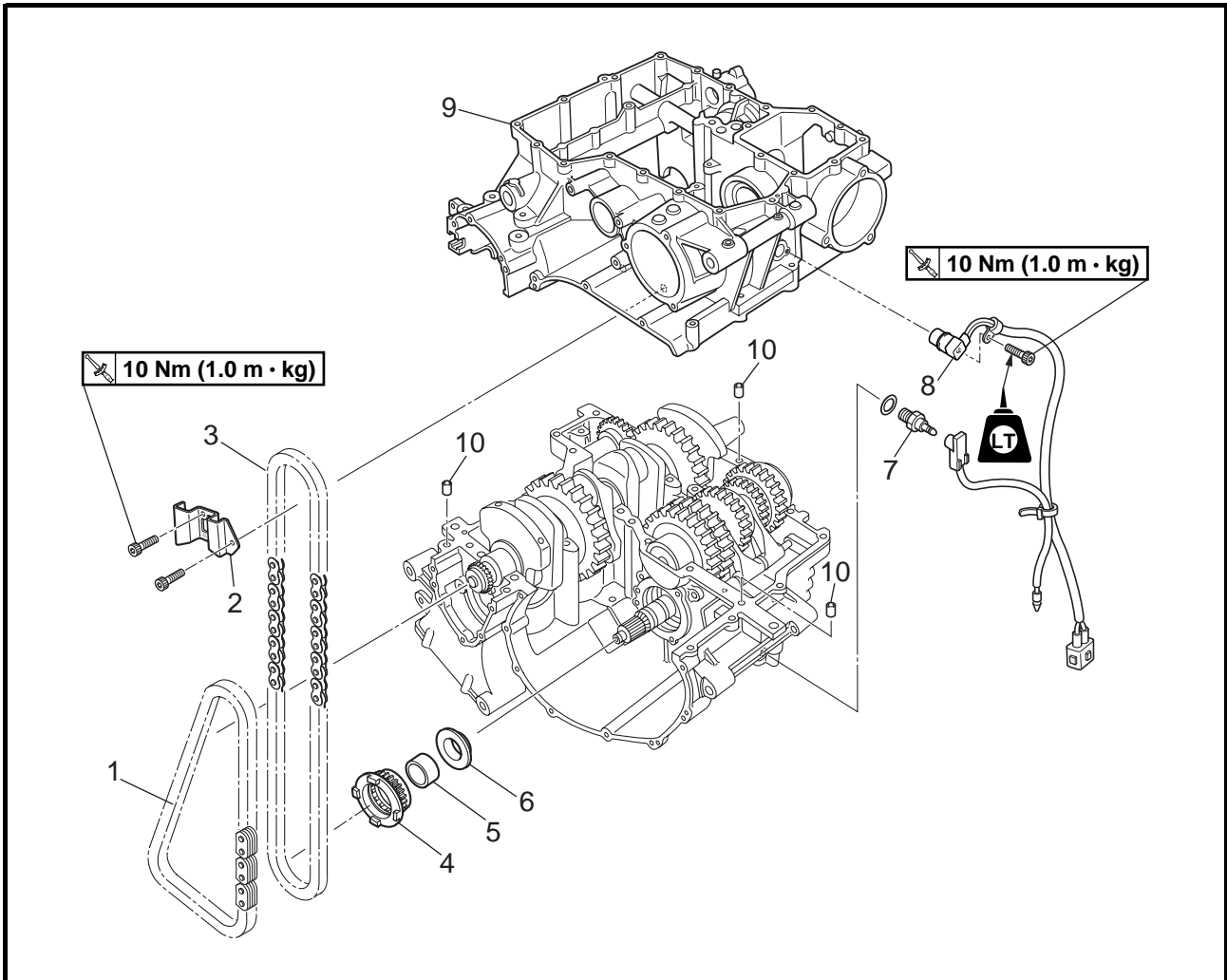

Order	Job/Part	Q'ty	Remarks
	Separating the crankcase		Remove the parts in the order listed.
	Engine		Refer to "ENGINE".
	Cylinder head		Refer to "CYLINDER HEAD".
	Generator rotor		Refer to "GENERATOR AND STARTER CLUTCH".
	Pickup coil rotor		Refer to "PICKUP COIL ROTOR".
	Stopper lever		Refer to "SHIFT SHAFT".
	Oil pump		Refer to "OIL PAN AND OIL PUMP".
	Middle drive shaft		Refer to "MIDDLE GEAR".
1	Timing chain	1	
2	Oil pump drive chain guide	1	
3	Oil pump drive chain	1	
4	Oil pump drive sprocket	1	

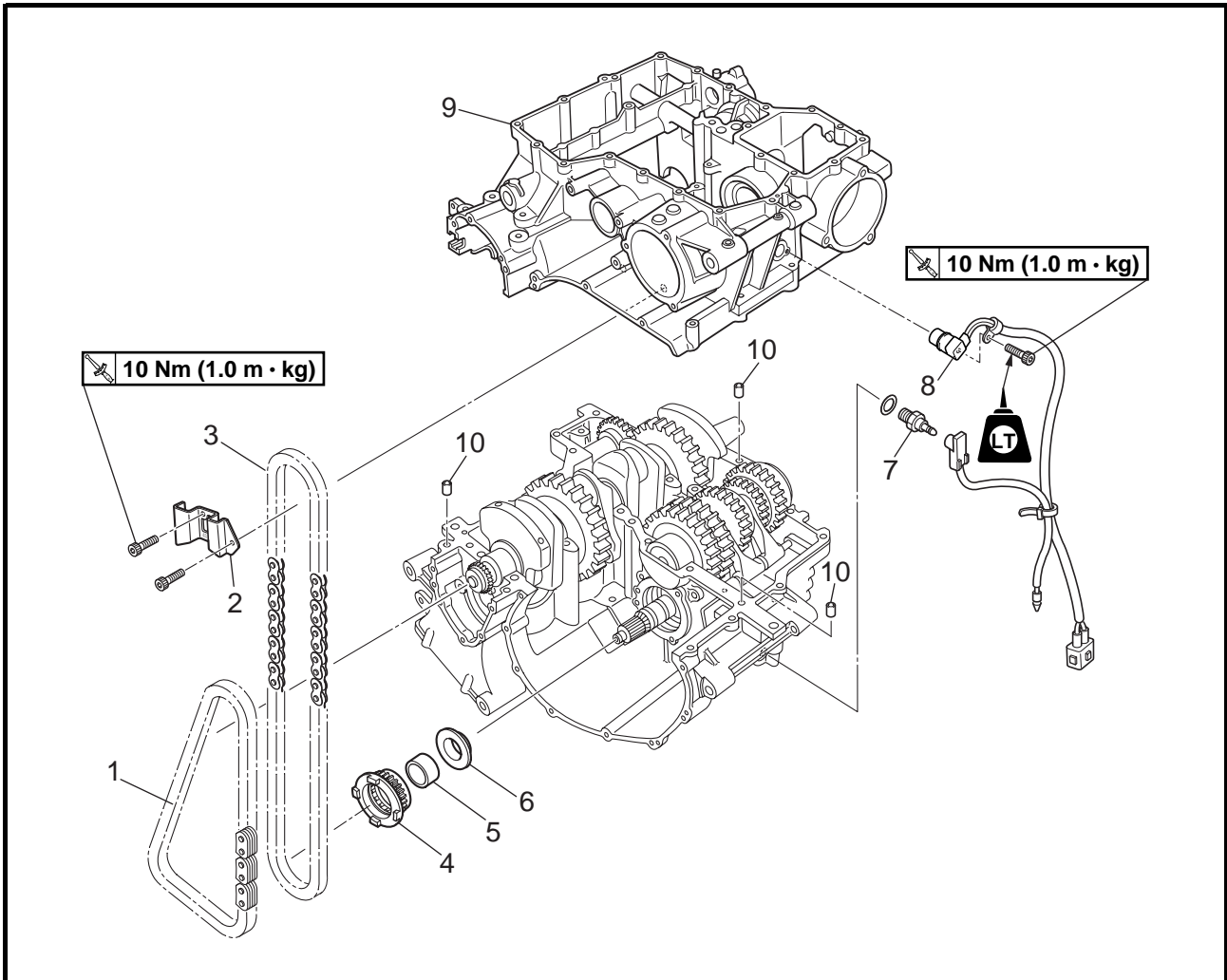

Order	Job/Part	Q'ty	Remarks
5	Collar	1	
6	Spacer	1	
7	Neutral switch	1	
8	Speed sensor	1	
9	Lower crankcase	1	Refer to "DISASSEMBLING/ASSEMBLING THE CRANKCASE".
10	Dowel pin	3	For installation, reverse the removal procedure.

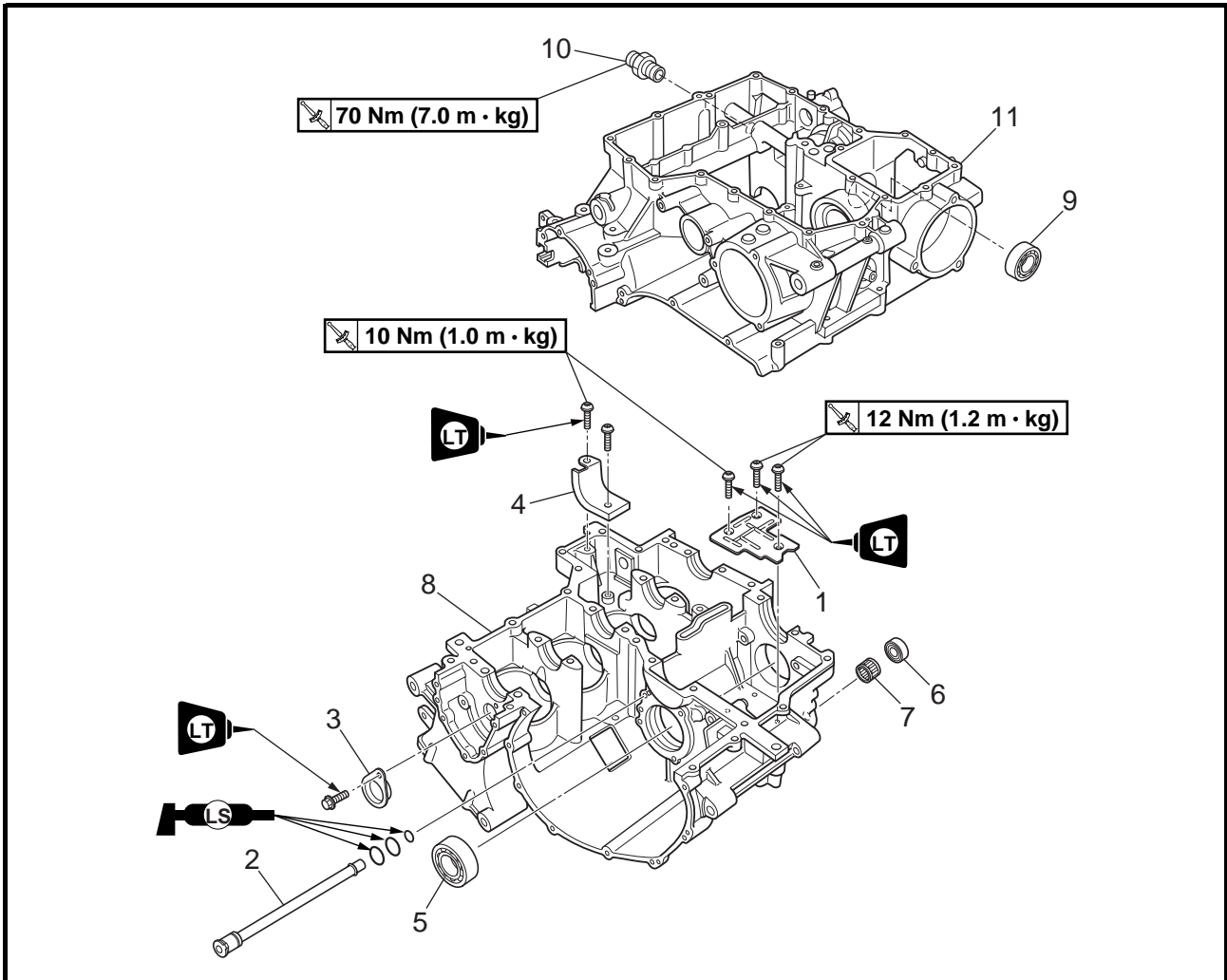

Order	Job/Part	Q'ty	Remarks
	Removing the oil baffle plates and bearings		Remove the parts in the order listed.
	Connecting rod assemblies		Refer to "CONNECTING RODS AND PISTONS".
	Crankshaft/crankshaft journal bearings		Refer to "CRANKCASE".
	Transmission		Refer to "TRANSMISSION".
1	Oil baffle plate	1	
2	Oil delivery pipe	1	
3	Plate	1	
4	Oil baffle plate	1	
5	Bearing	1	

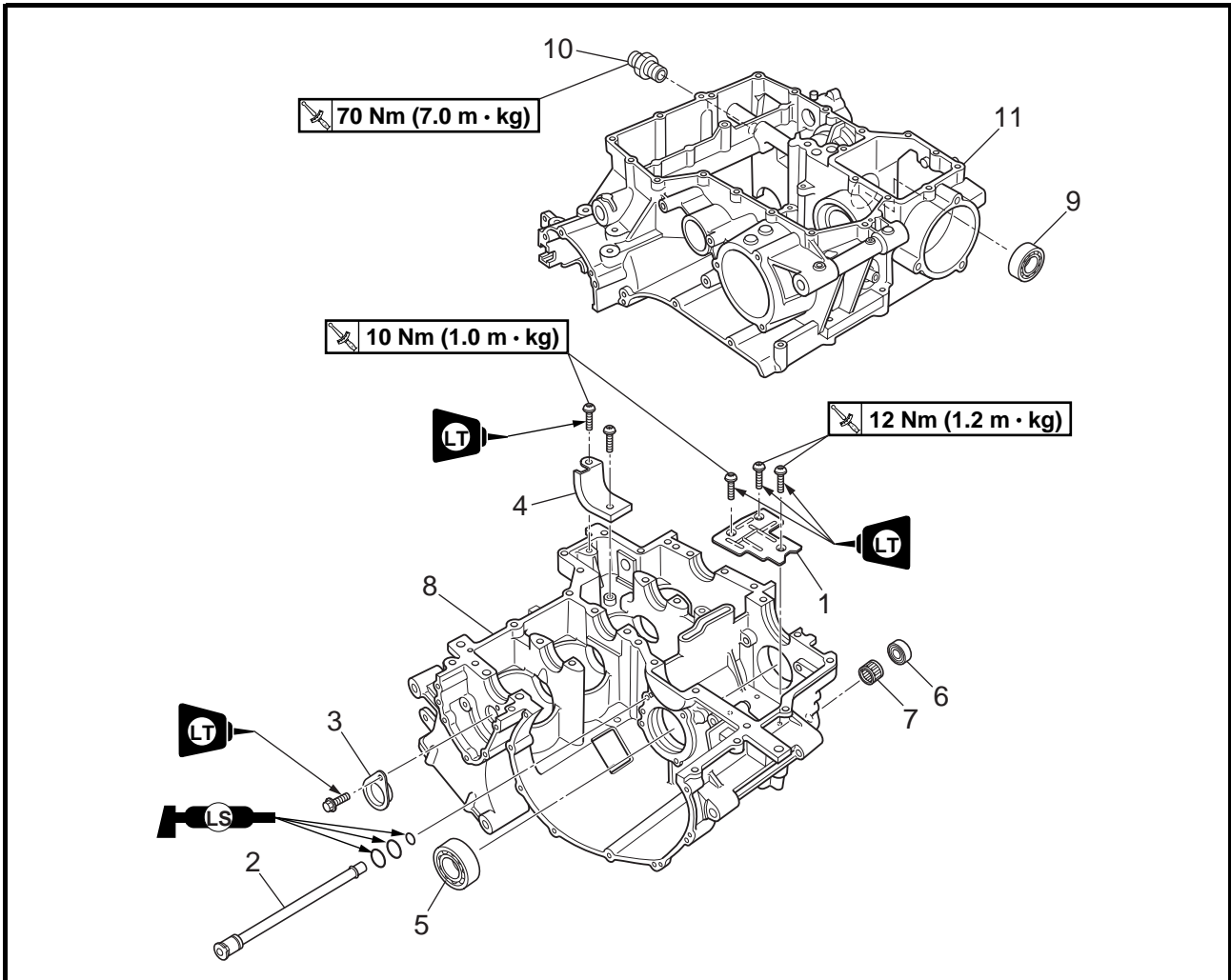

Order	Job/Part	Q'ty	Remarks
6	Oil seal	1	For installation, reverse the removal procedure.
7	Bearing	1	
8	Upper crankcase	1	
9	Bearing	1	
10	Oil filter bolt	1	
11	Lower crankcase	1	

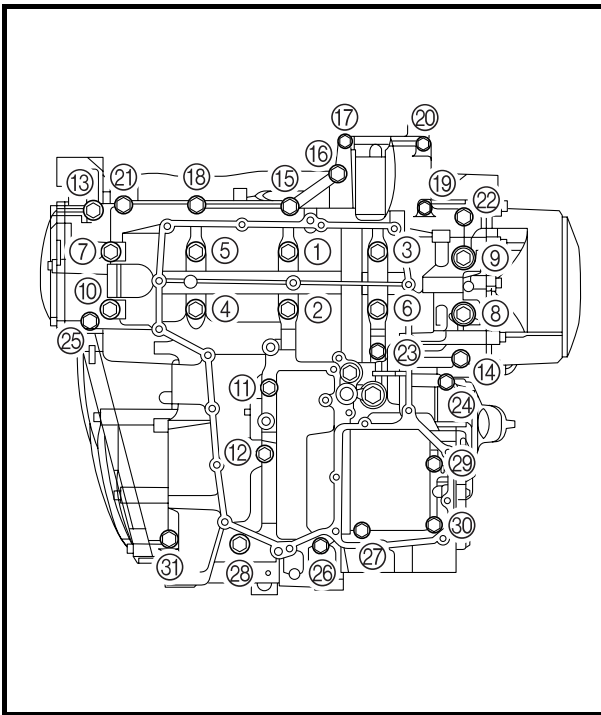

EAS00384

DISASSEMBLING THE CRANKCASE

1. Remove:

- crankcase bolts

NOTE:

- Loosen each bolt 1/4 of a turn at a time, in stages and in a crisscross pattern. After all of the bolts are fully loosened, remove them.
- Loosen the bolts in decreasing numerical order (refer to the numbers in the illustration).
- The numbers embossed on the crankcase indicate the crankcase tightening sequence.

2. Place the engine upside down.

3. Remove:

- lower crankcase

CAUTION:

Tap on one side of the crankcase with a soft-face hammer. Tap only on reinforced portions of the crankcase, not on the crankcase mating surfaces. Work slowly and carefully and make sure the crankcase halves separate evenly.

M9 × 115 mm bolts: ① ~ ⑩

M8 × 65 mm bolts: ⑪

M8 × 50 mm bolts: ⑫

M6 × 80 mm bolts: ⑲, ⑳

M6 × 65 mm bolts: ⑬, ⑭

M6 × 65 mm bolts: ⑱, ⑳, ㉔, ㉖

M6 × 55 mm bolts: ⑮ ~ ⑱, ㉒, ㉓, ㉗ ~ ㉚

M6 × 45 mm bolts: ㉛

4. Remove:

- dowel pins



EAS00399

CHECKING THE CRANKCASE

1. Thoroughly wash the crankcase halves in a mild solvent.
2. Thoroughly clean all the gasket surfaces and crankcase mating surfaces.
3. Check:
 - crankcase
Cracks/damage → Replace.
 - oil delivery passages
Obstruction → Blow out with compressed air.

EAS00401

CHECKING THE BEARINGS AND OIL SEALS

1. Check:
 - bearings
Clean and lubricate the bearings, then rotate the inner race with your finger.
Rough movement → Replace.
2. Check:
 - oil seals
Damage/wear → Replace.

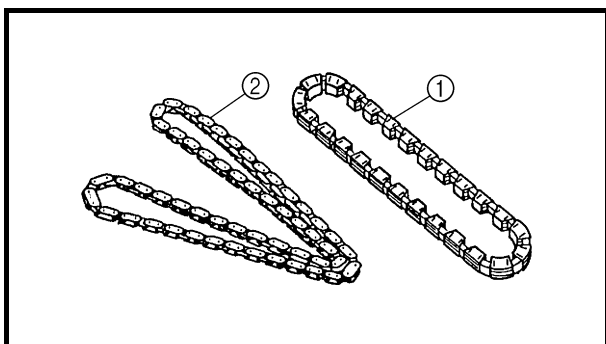

EAS00208

CHECKING THE TIMING CHAIN AND OIL PUMP DRIVE CHAIN

The following procedure applies to all of the camshaft sprockets and timing chain guides.

1. Check:

- timing chain ①
Damage/stiffness → Replace the timing chain and camshaft sprockets as a set.
- oil pump drive chain ②
Damage/stiffness → Replace the oil pump drive chain, oil pump drive sprocket and oil pump shaft as a set.

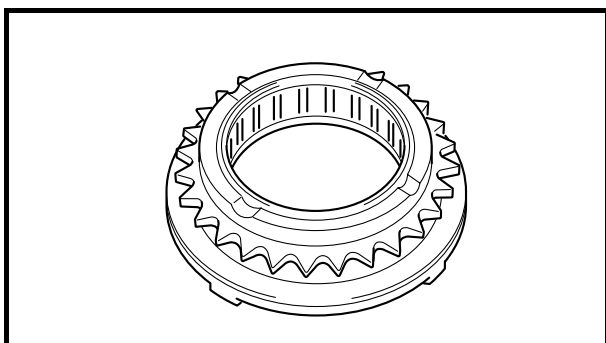

2. Check:

- oil pump drive sprocket
Cracks/damage/wear → Replace the oil pump drive sprocket and the oil pump drive chain as a set.

EAS00413

ASSEMBLING THE CRANKCASE

1. Lubricate:

- crankshaft journal bearings
(with the recommended lubricant)



Recommended lubricant
Engine oil

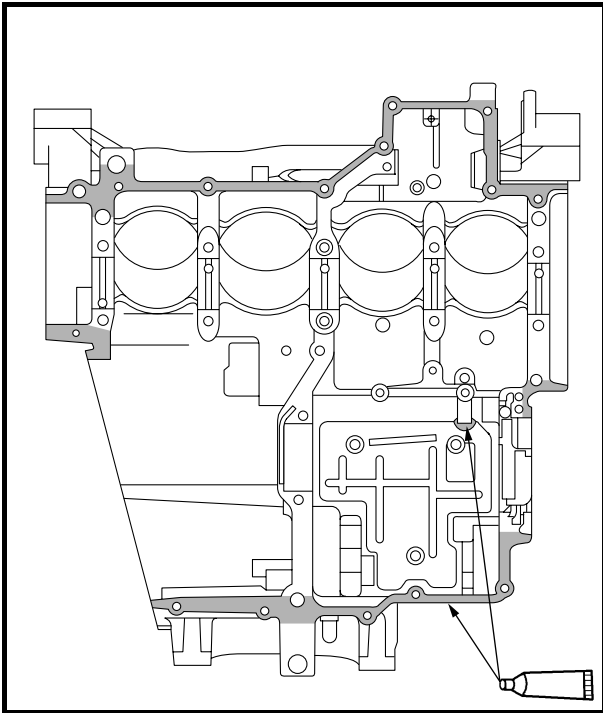

2. Apply:
- sealant
(onto the crankcase mating surfaces)



Yamaha bond No. 1215
90890-85505

NOTE:

Do not allow any sealant to come into contact with the oil gallery or crankshaft journal bearings. Do not apply sealant to within 2 ~ 3 mm of the crankshaft journal bearings.

3. Install:
- dowel pins

4. Set the shift drum assembly and transmission gears in the neutral position.

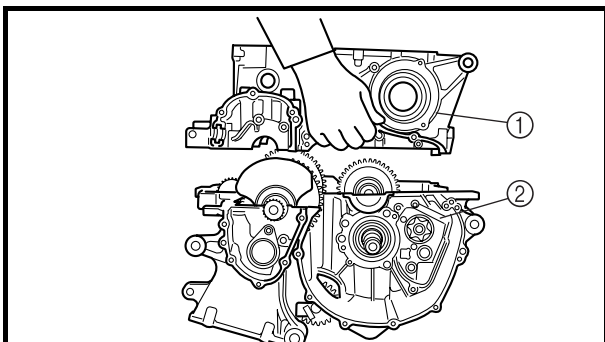

5. Install:
- lower crankcase ①
(onto the upper crankcase ②)

CAUTION:

Before tightening the crankcase bolts, make sure the transmission gears shift correctly when the shift drum assembly is turned by hand.

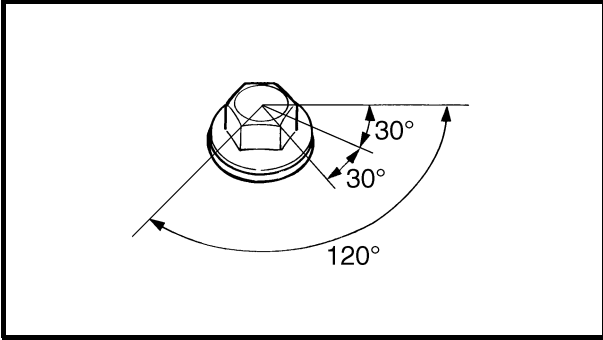

c. Tighten the crankcase bolts further to reach the specified angle 120° in the proper tightening sequence as shown.

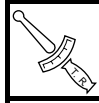

Crankcase bolt ① ~ ⑩
Final
Specified angle 120°

⚠ WARNING

When the bolts are tightened more than the specified angle, do not loosen the bolt and then retighten it.

Replace the bolt with a new one and perform the procedure again.

CAUTION:

- Do not use a torque wrench to tighten the bolt to the specified angle.
- Tighten the bolt until it is at the specified angle.

NOTE:

When using a hexagonal bolt, note that the angle from one corner to another is 60°.

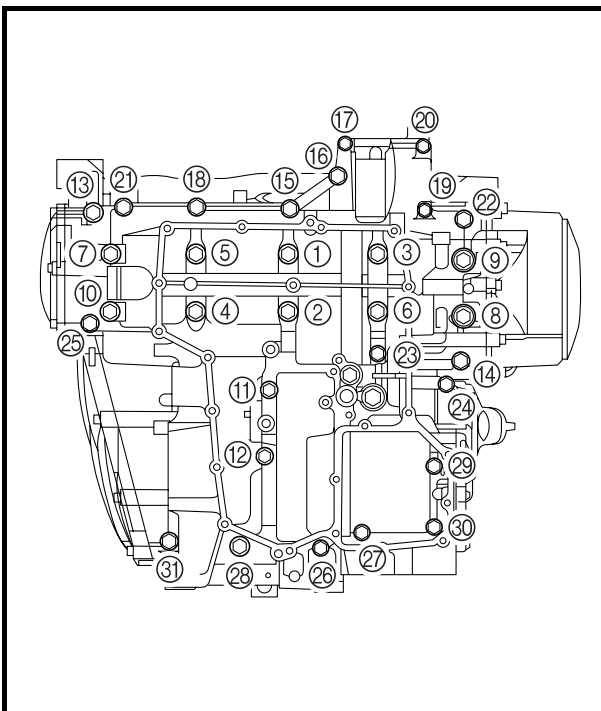

8. Tighten:

- crankcase bolts ⑪ ~ ⑳

NOTE:

Tighten the bolts in the tightening sequence cast on the crankcase.



Bolt ⑪, ⑫
24 Nm (2.4 m · kg)
Bolt ⑬, ⑭
12 Nm (1.2 m · kg)
Bolt ⑮ ~ ⑳
10 Nm (1.0 m · kg)

EAS00252

CONNECTING RODS AND PISTONS

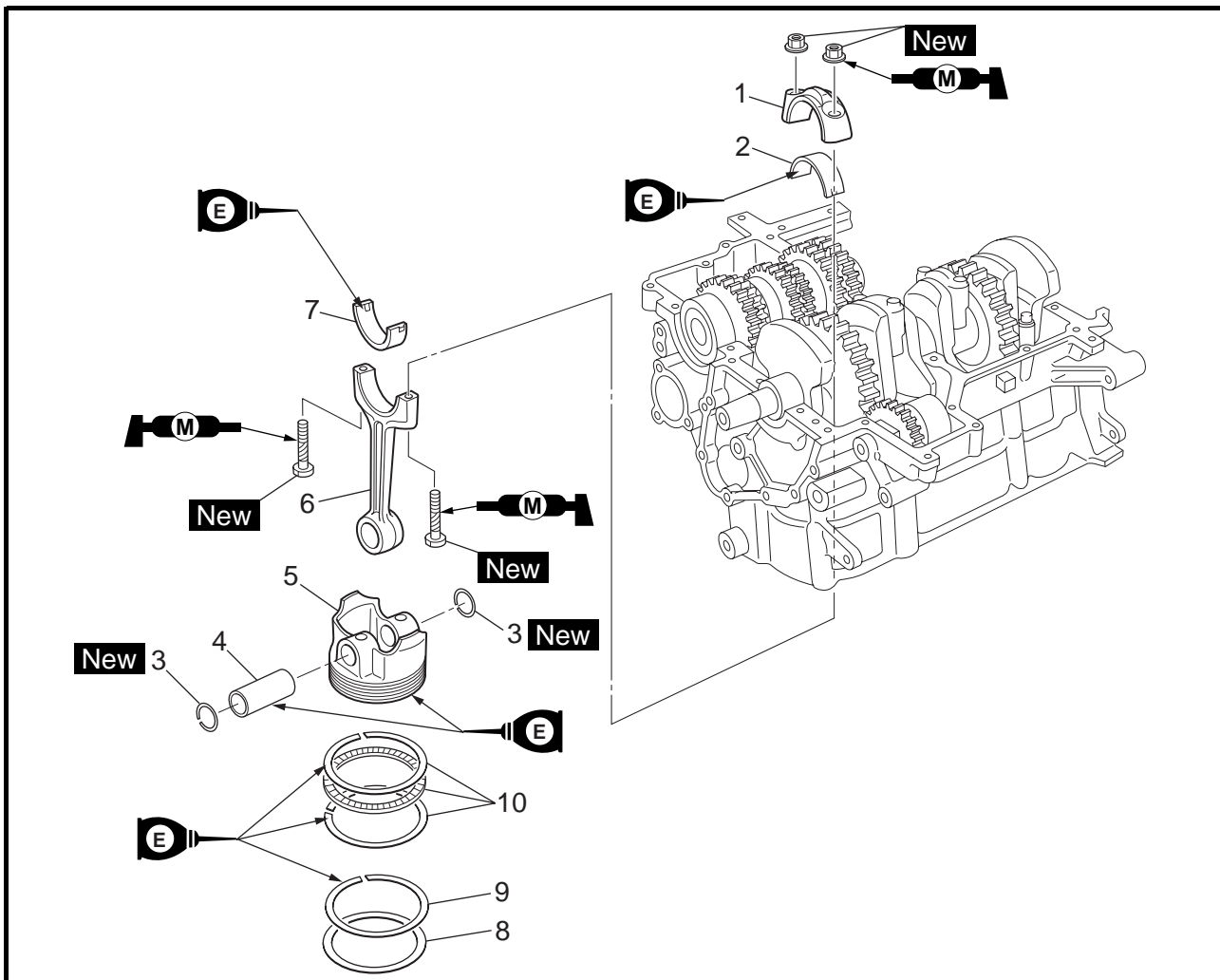

Order	Job/Part	Q'ty	Remarks
	Removing the connecting rods and pistons		Remove the parts in the order listed.
	Crankcase		Separate. Refer to "CRANKCASE".
1	Connecting rod cap	4	Refer to "REMOVING THE CONNECTING RODS AND PISTONS" and "INSTALLING THE CONNECTING RODS AND PISTONS".
2	Big end lower bearing	4	
3	Piston pin clip	8	
4	Piston pin	4	
5	Piston	4	
6	Connecting rod	4	
7	Big end upper bearing	4	
8	Top ring	4	
9	2nd ring	4	
10	Oil ring	4	
			For installation, reverse the removal procedure.

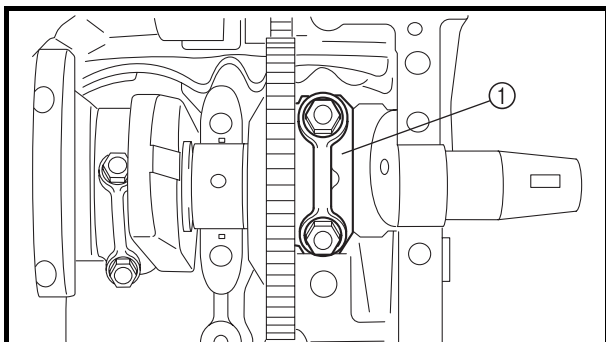

EAS00393

REMOVING THE CONNECTING RODS AND PISTONS

The following procedure applies to all of the connecting rods and pistons.

1. Remove:
 - connecting rod cap ①
 - big end bearings

NOTE: _____

Identify the position of each big end bearing so that it can be reinstalled in its original place.

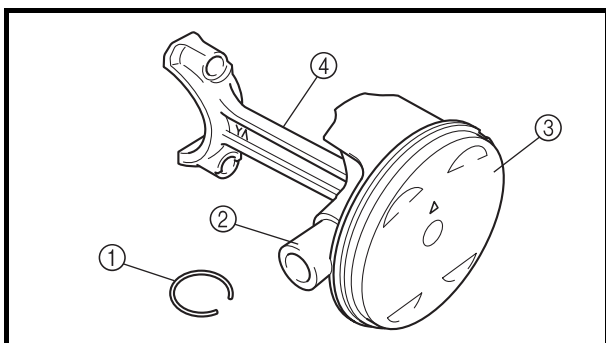

2. Remove:
 - piston pin clips ①
 - piston pin ②
 - piston ③
 - connecting rod ④

CAUTION: _____

Do not use a hammer to drive the piston pin out.

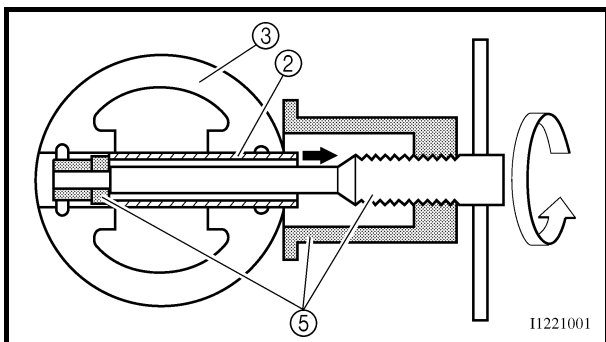

NOTE: _____

- For reference during installation, put identification marks on the piston crown.
 - Before removing the piston pin, deburr the piston pin clip's groove and the piston's pin bore area. If both areas are deburred and the piston pin is still difficult to remove, remove it with the piston pin puller ⑤.
-



Piston pin puller
90890-01304

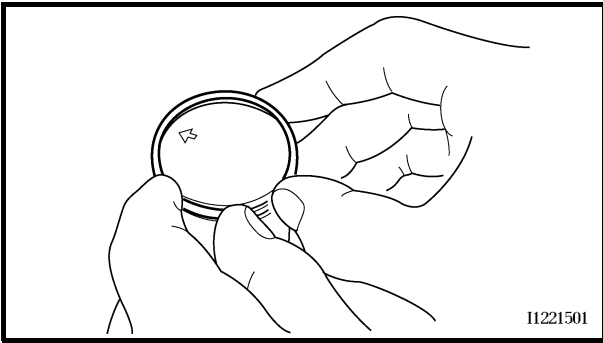

3. Remove:

- top ring
- 2nd ring
- oil ring

NOTE:

When removing a piston ring, open the end gap with your fingers and lift the other side of the ring over the piston crown.

EAS00258

CHECKING THE CYLINDERS AND PISTONS

The following procedure applies to all of the cylinders and pistons.

1. Check:

- piston wall
- cylinder wall

Vertical scratches → Replace the cylinder, and the piston and piston rings as a set.

2. Measure:

- piston-to-cylinder clearance



a. Measure cylinder bore "C" with the cylinder bore gauge.

NOTE:

Measure cylinder bore "C" by taking side-to-side and front-to-back measurements of the cylinder. Then, find the average of the measurements.

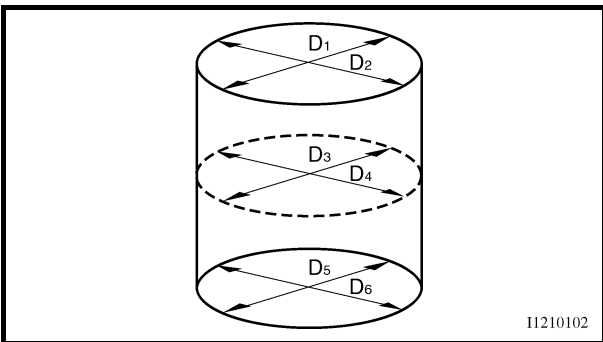

Cylinder bore "C"	79.00 ~ 79.01 mm
Taper limit "T"	0.05 mm
Out of round "R"	0.05 mm

"C" = maximum of D1 ~ D6
"T" = maximum of D1 or D2 – maximum of D5 or D6
"R" = maximum of D1, D3 or D5 – minimum of D2, D4 or D6

b. If out of specification, replace the cylinder, and the piston and piston rings as a set.

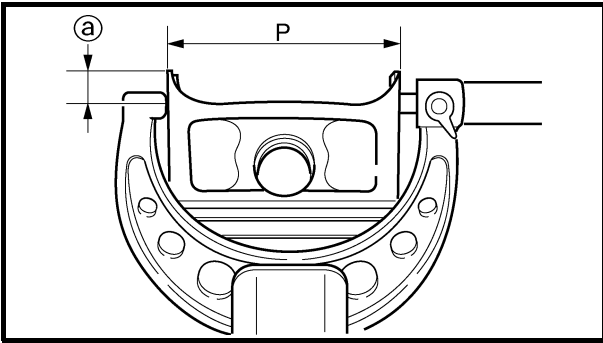

- c. Measure piston skirt diameter “P” with the micrometer.
- Ⓐ 5 mm from the bottom edge of the piston

	Piston size “P”
Standard	78.965 ~ 78.980 mm

- d. If out of specification, replace the piston and piston rings as a set.
- e. Calculate the piston-to-cylinder clearance with the following formula.

**Piston-to-cylinder clearance =
Cylinder bore “C” –
Piston skirt diameter “P”**

	Piston-to-cylinder clearance 0.020 ~ 0.045 mm <Limit>: 0.012 mm
--	--

- f. If out of specification, replace the cylinder, and the piston and piston rings as a set.

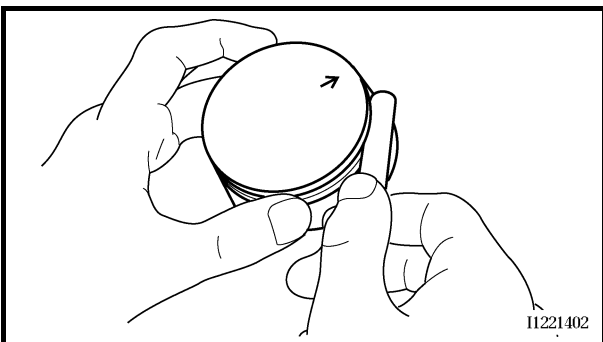

EAS00263

CHECKING THE PISTON RINGS

- 1. Measure:
 - piston ring side clearance
 Out of specification → Replace the piston and piston rings as a set.

NOTE: _____
 Before measuring the piston ring side clearance, eliminate any carbon deposits from the piston ring grooves and piston rings.

	Piston ring side clearance Top ring 0.03 ~ 0.07 mm <Limit>: 0.12 mm 2nd ring 0.02 ~ 0.06 mm <Limit>: 0.12 mm
--	---

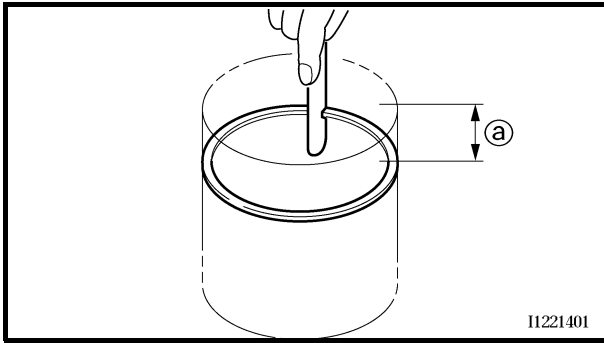

2. Install:
 - piston ring
(into the cylinder)

NOTE: _____
 Level the piston ring in the cylinder with the piston crown.

@ 5 mm

3. Measure:
 - piston ring end gap
Out of specification → Replace the piston ring.

NOTE: _____
 The oil ring expander spacer's end gap cannot be measured. If the oil ring rail's gap is excessive, replace all three piston rings.



Piston ring end gap

- Top ring**
0.35 ~ 0.45 mm
<Limit>: 0.70 mm
- 2nd ring**
0.75 ~ 0.85 mm
<Limit>: 1.20 mm
- Oil ring**
0.2 ~ 0.6 mm

EAS00266

CHECKING THE PISTON PINS

The following procedure applies to all of the piston pins.

1. Check:
 - piston pin
Blue discoloration/grooves → Replace the piston pin and then check the lubrication system.

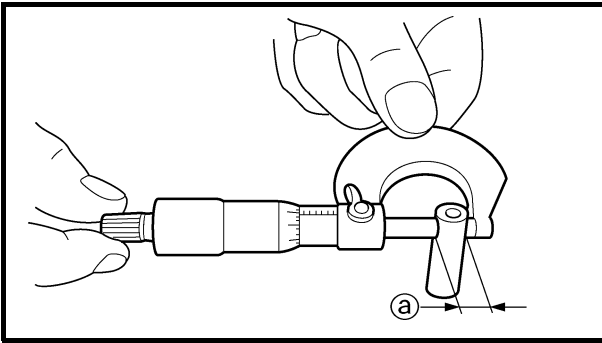

2. Measure:

- piston pin outside diameter (a)
Out of specification → Replace the piston pin.



Piston pin outside diameter
11.9 ~ 12.1 mm
<Limit>: 11.88 mm

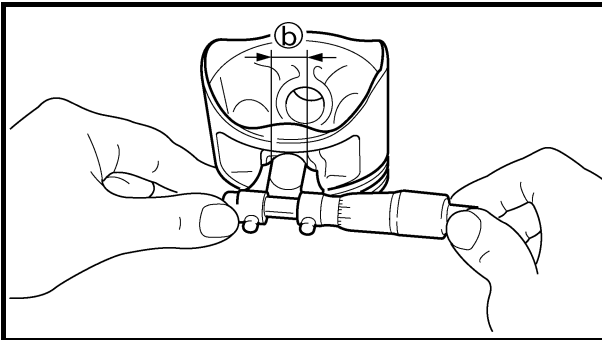

3. Measure:

- piston pin bore diameter (in the piston) (b)
Out of specification → Replace the piston.



Piston pin bore diameter (in the piston)
19.004 ~ 19.015 mm
<Limit>: 19.045 mm

4. Calculate:

- piston-pin-to-piston clearance
Out of specification → Replace the piston pin.

Piston-pin-to-piston clearance =
Piston pin bore diameter (in the piston)
(b) –
Piston pin outside diameter (a)



Piston-pin-to-piston clearance
6.904 ~ 7.115 mm
<Limit>: 7.165 mm

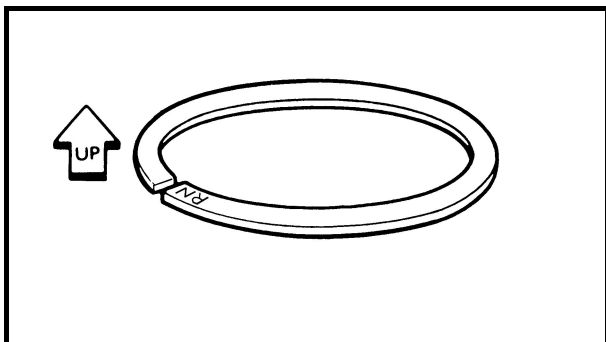

EAS00271
EAS00404

INSTALLING THE CONNECTING RODS AND PISTONS

The following procedure applies to all of the pistons and connecting rods.

1. Install:
 - top ring
 - 2nd ring
 - oil ring

NOTE:

Be sure to install the piston rings so that the manufacturer's marks or numbers face up.

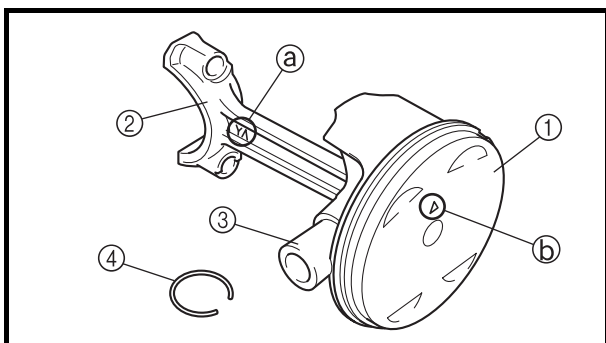

2. Install:

- piston ①
- connecting rod ②
- piston pin ③
- piston pin clip ④ **New**

NOTE:

- Apply engine oil onto the piston pin.
- Make sure that the "Y" mark **a** on the connecting rod left when the arrow mark **b** on the piston is pointing up. Refer to the illustration.
- Reinstall each piston into its original cylinder (numbering order starting from the left: #1 to #4).

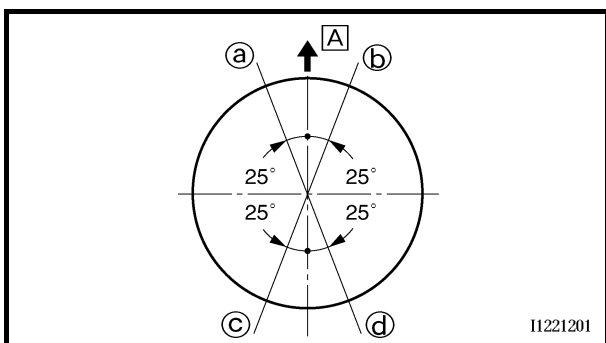

11221201

3. Offset:

- piston ring end gaps
- Ⓐ Top ring
- Ⓑ Lower oil ring rail
- Ⓒ Upper oil ring rail
- Ⓓ 2nd ring
- Ⓐ Intake side

4. Lubricate:
- piston
 - piston rings
 - cylinder
- (with the recommended lubricant)

	Recommended lubricant Engine oil
---	---

5. Lubricate:
- bolt threads
 - nut seats
- (with the recommended lubricant)

	Recommended lubricant Molybdenum disulfide grease
---	--

6. Lubricate:
- crankshaft pins
 - big end bearings
 - connecting rod inner surface
- (with the recommended lubricant)

	Recommended lubricant Engine oil
---	---

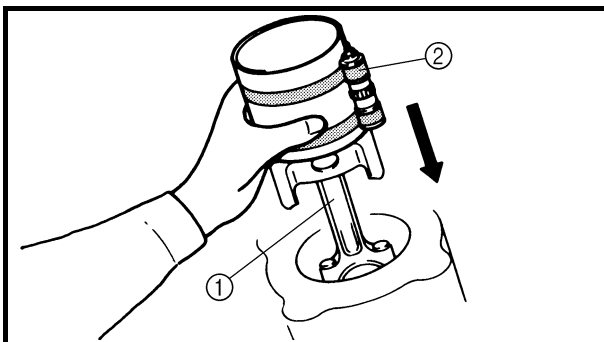

7. Install:
- big end bearings
 - connecting rod assembly ①
(into the cylinder and onto the crankshaft pin)
 - connecting rod cap
(onto the crankshaft pin)

- NOTE:**
- Align the projections on the big end bearings with the notches in the connecting rods and connecting rod caps.
 - Be sure to reinstall each big end bearing in its original place.
 - While compressing the piston rings with piston ring compressor ②, install the connecting rod assembly into the cylinder with the other hand.



⚠ WARNING

When the nuts are tightened more than the specified angle, do not loosen the nut and then retighten it.
Replace the nut with a new one and perform the procedure again.

CAUTION:

- Do not use a torque wrench to tighten the nut to the specified angle.
- Tighten the nut until it is at the specified angle.

NOTE:

When using a hexagonal nut, note that the angle from one corner to another is 60°.





EAS00381

CRANKSHAFT

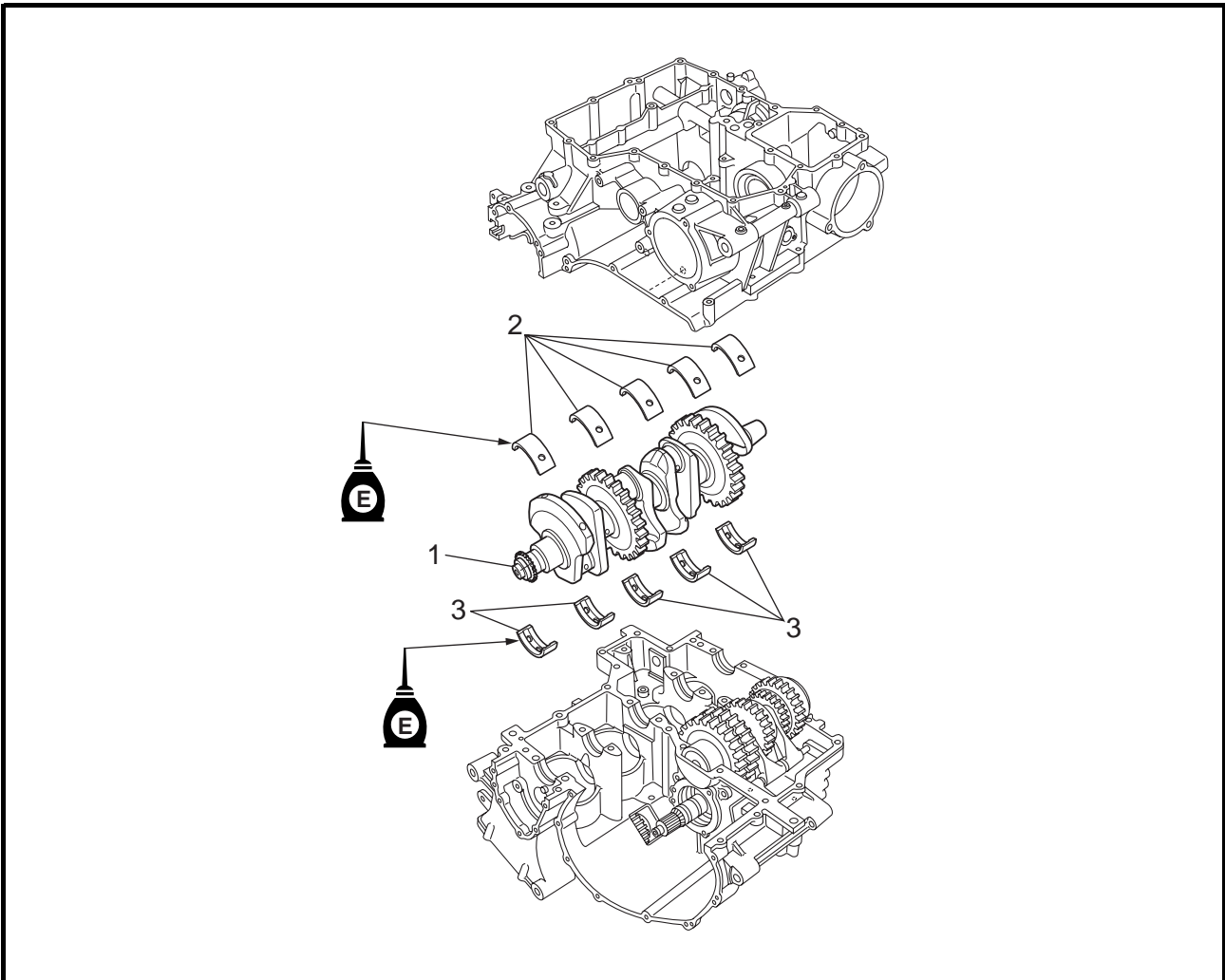

Order	Job/Part	Q'ty	Remarks
	Removing the crankshaft		Remove the parts in the order listed.
	Crankcase		Separate. Refer to "CRANKCASE".
	Connecting rod caps		Refer to "CONNECTING RODS AND PISTONS".
1	Crankshaft	1	Refer to "REMOVING/INSTALLING THE CRANKSHAFT".
2	Crankshaft journal lower bearing	5	
3	Crankshaft journal upper bearing	5	
			For installation, reverse the removal procedure.

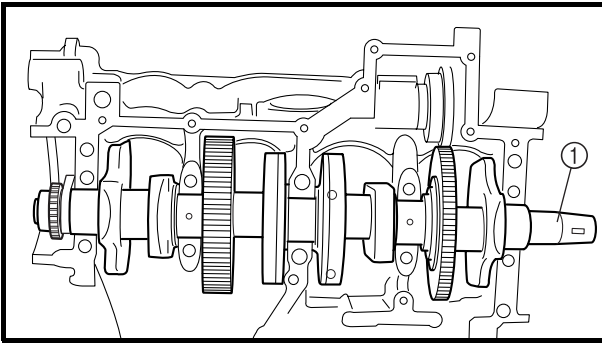

EAS00387

REMOVING THE CRANKSHAFT

1. Remove:

- crankshaft ①
- crankshaft journal lower bearings (from the lower crankcase)
- crankshaft journal upper bearings (from the upper crankcase)

NOTE:

Identify the position of each crankshaft journal bearing so that it can be reinstalled in its original place.

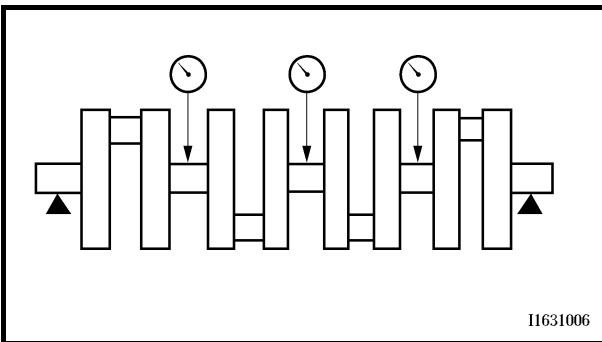

EAS00396

CHECKING THE CRANKSHAFT

1. Measure:

- crankshaft runout
Out of specification → Replace the crankshaft.



**Maximum crankshaft runout
0.03 mm**

2. Check:

- crankshaft journal surfaces
- crankshaft pin surfaces
- bearing surfaces
Scratches/wear → Replace the crankshaft.

3. Measure:

- crankshaft-journal-to-crankshaft-journal-bearing clearance
Out of specification → Replace the crankshaft journal bearings.



**Crankshaft-journal-to-crankshaft-journal-bearing clearance
0.027 ~ 0.045 mm**

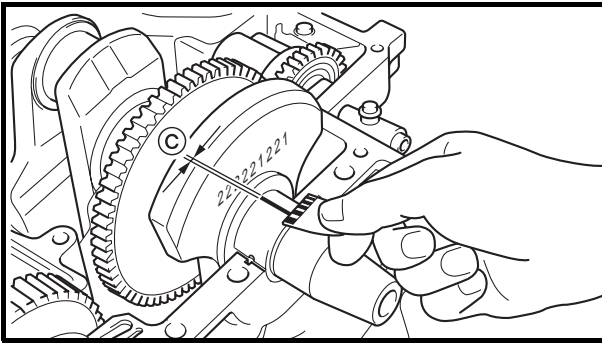

h. Measure the compressed Plastigauge® width © on each crankshaft journal.
If the crankshaft-journal-to-crankshaft-journal-bearing clearance is out of specification, select replacement crankshaft journal bearings.

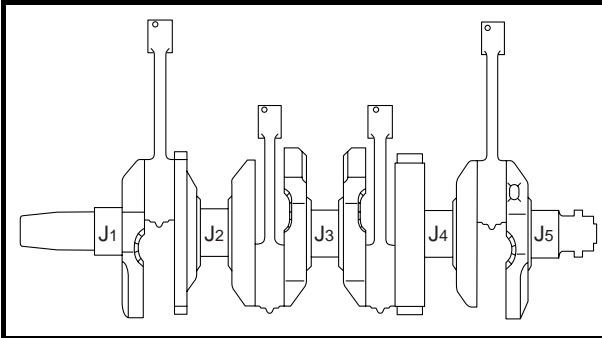

4. Select:
• Crankshaft journal bearings (J1 ~ J5)

NOTE:

- The numbers stamped into the crankshaft web and the numbers stamped into the lower crankcase are used to determine the replacement crankshaft journal bearing sizes.
- “J1 ~ J5” refer to the bearings shown in the crankshaft illustration.
- If “J1 ~ J5” are the same, use the same size for all of the bearings.

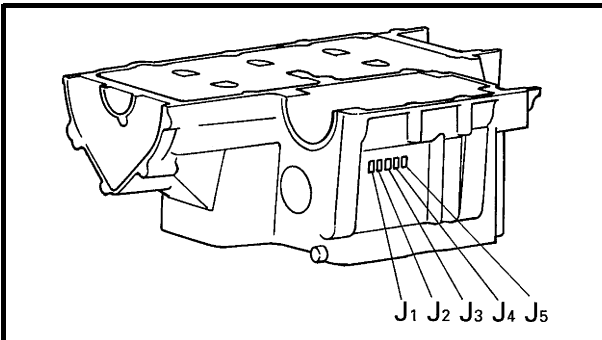

For example, if the crankcase “J1” and crankshaft web “J1” numbers are “6” and “2” respectively, then the bearing size for “J1” is:

Bearing size of J₁:

“J₁” (crankcase) – “J₁” (crankshaft web)
+ 2
6 – 2 + 2 = 6 (pink)

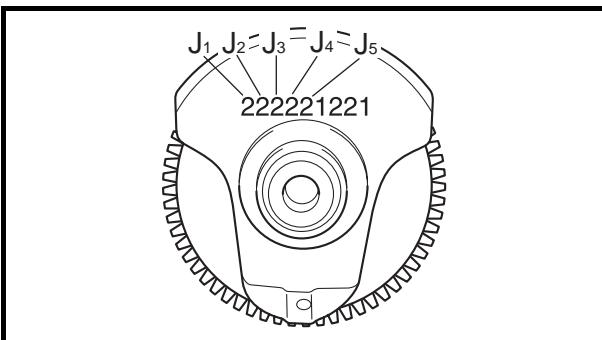

BEARING COLOR CODE	
2	black
3	brown
4	green
5	yellow
6	pink
7	red
8	white



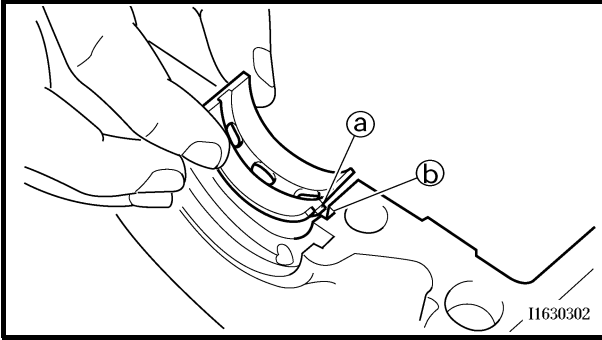

EAS00407

INSTALLING THE CRANKSHAFT

1. Install:

- crankshaft journal upper bearings (into the upper crankcase)
- crankshaft journal lower bearings (into the lower crankcase)

NOTE:

- Align the projections (a) on the crankshaft journal upper bearings with the notches (b) in the upper crankcase.
- Be sure to install each crankshaft journal bearing in its original place.

2. Lubricate:

- crankshaft pins
- connecting rod inner surface (with the recommended lubricant)

**Recommended lubricant
Engine oil**



EAS00419

TRANSMISSION

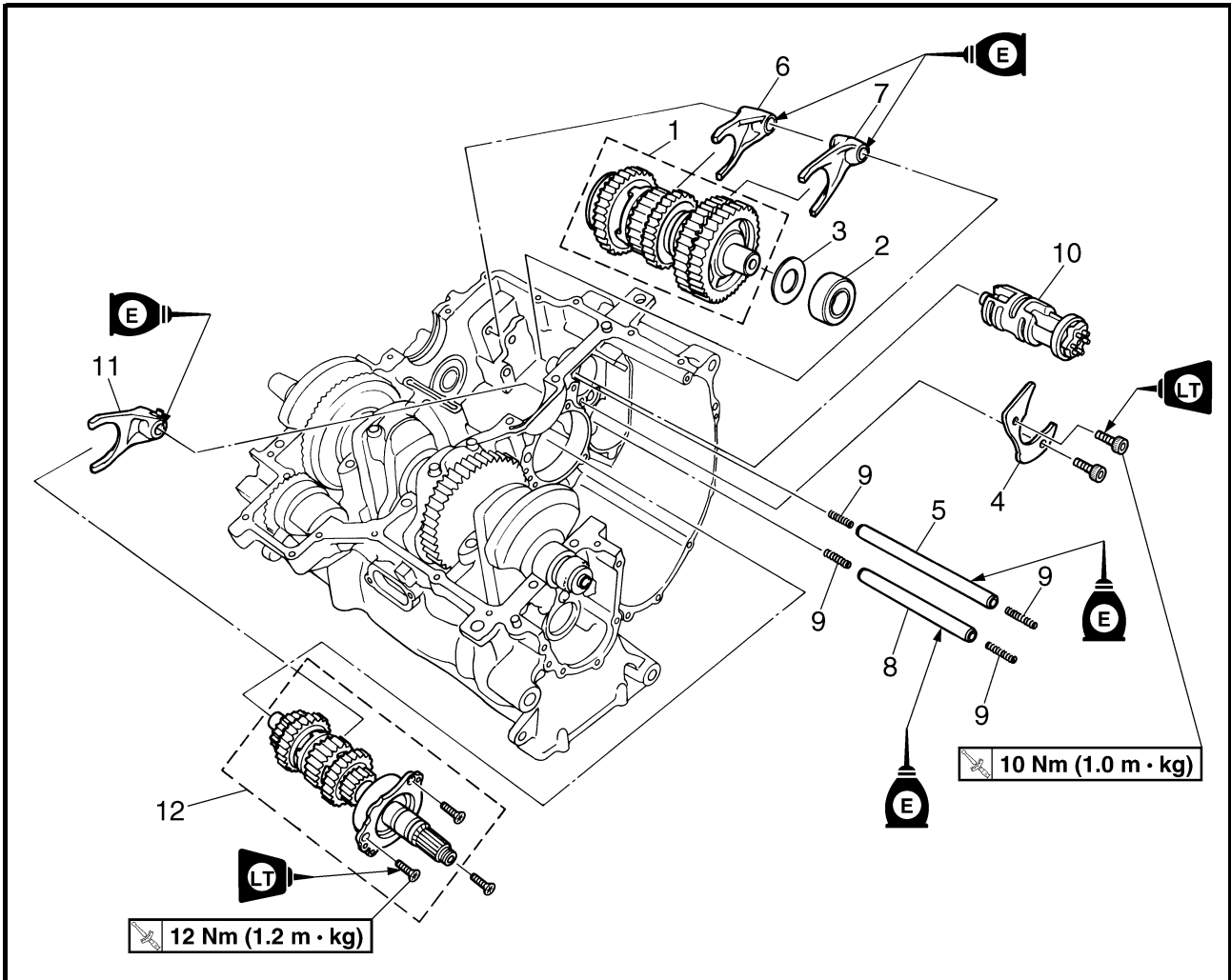

Order	Job/Part	Q'ty	Remarks
	Removing the transmission, shift drum assembly, and shift forks		Remove the parts in the order listed.
	Crankcase		Separate. Refer to "CRANKCASE".
1	Drive axle assembly	1	Refer to "INSTALLING THE TRANSMISSION".
2	Bearing	1	
3	Washer	1	
4	Shift drum retainer	1	
5	Long shift fork guide bar	1	
6	Shift fork "L"	1	
7	Shift fork "R"	1	
8	Short shift fork guide bar	1	
9	Spring	4	

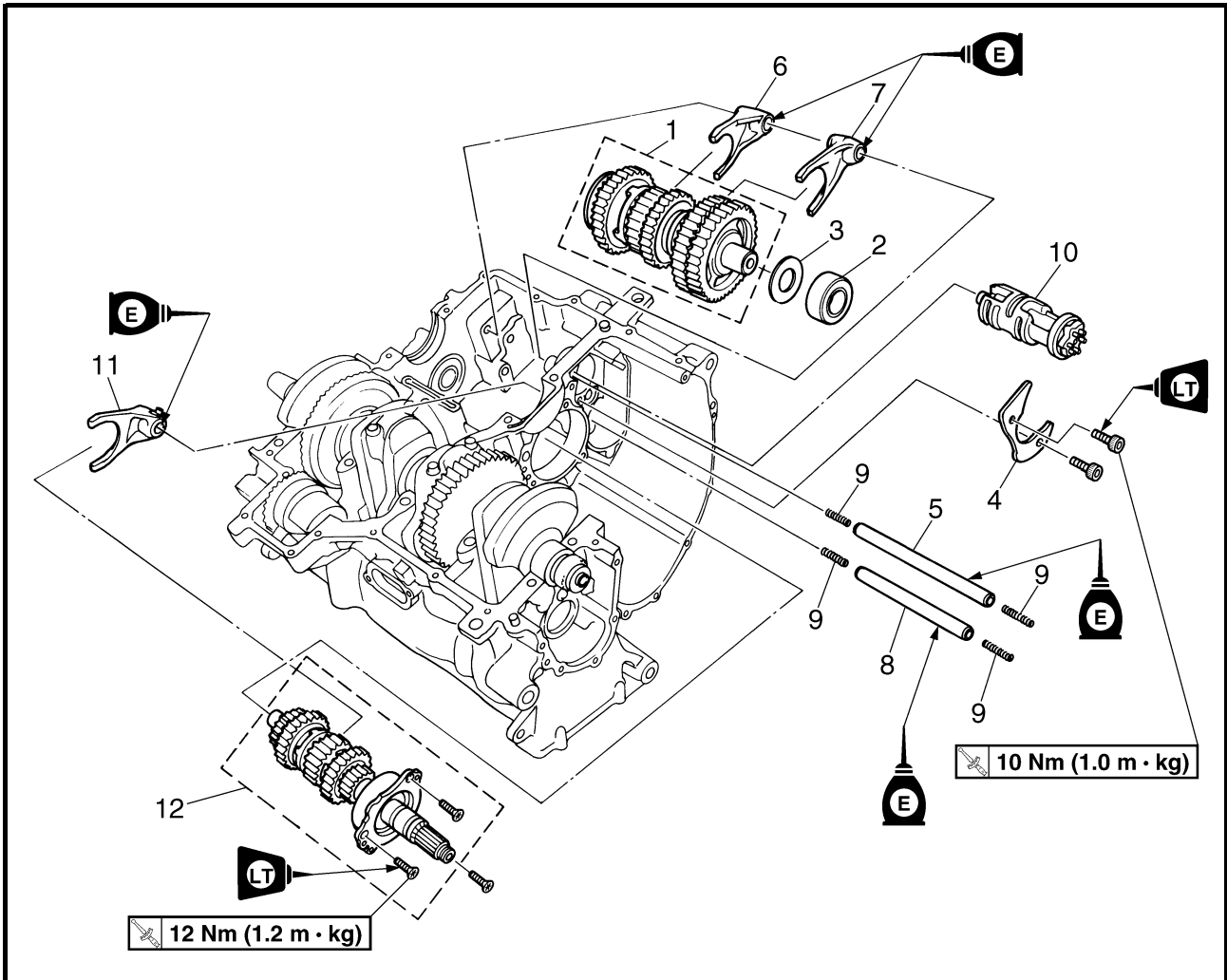

Order	Job/Part	Q'ty	Remarks
10	Shift drum assembly	1	Refer to "INSTALLING THE TRANSMISSION".
11	Shift fork "C"	1	
12	Main axle assembly	1	

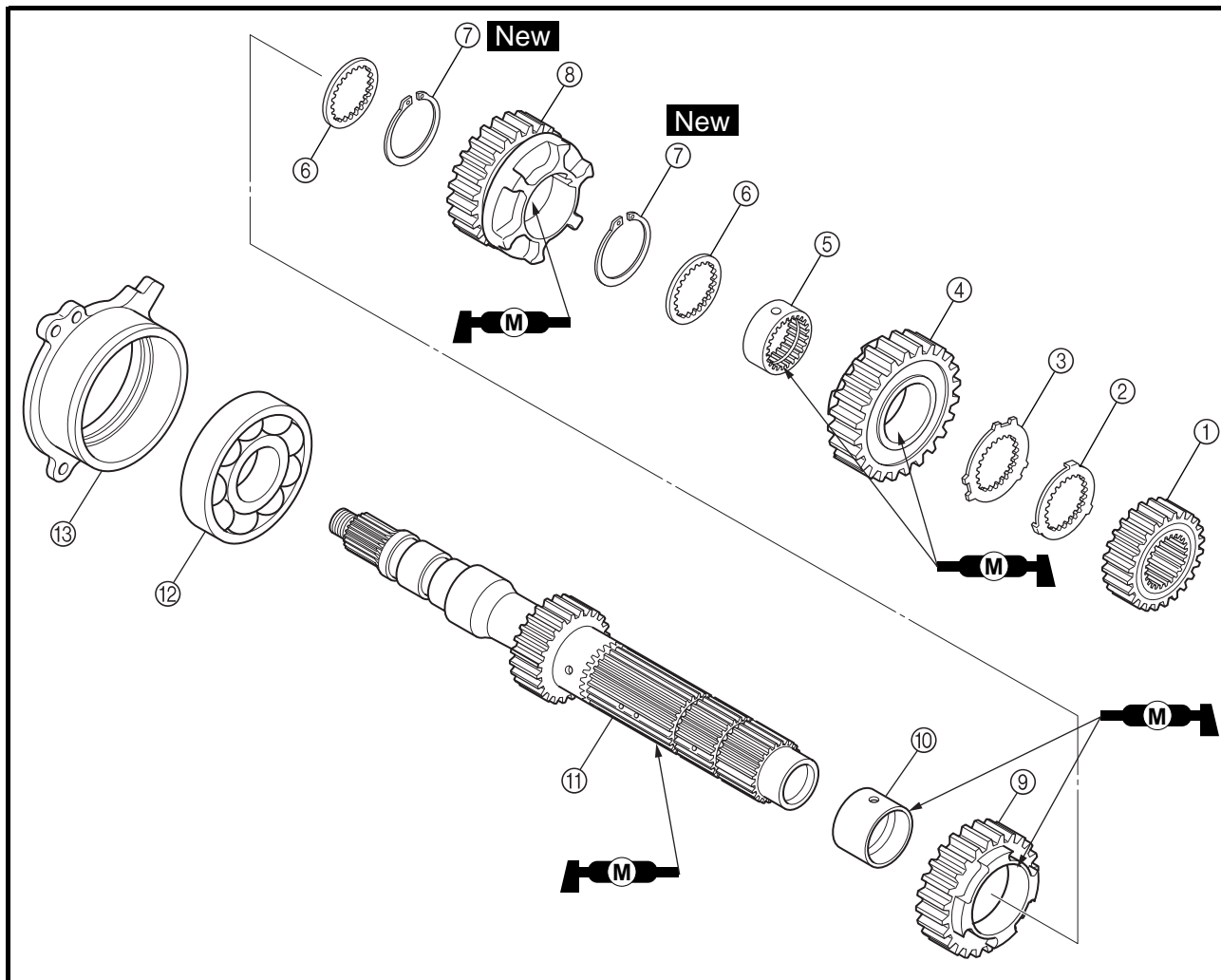

Order	Job/Part	Q'ty	Remarks
	Disassembling the main axle assembly		Remove the parts in the order listed.
①	2nd pinion gear	1	
②	Toothed lock washer	1	
③	Toothed lock washer retainer	1	
④	5th pinion gear	1	
⑤	Toothed spacer	1	
⑥	Toothed washer	2	
⑦	Circlip	2	
⑧	3rd pinion gear	1	
⑨	4th pinion gear	1	
⑩	Collar	1	

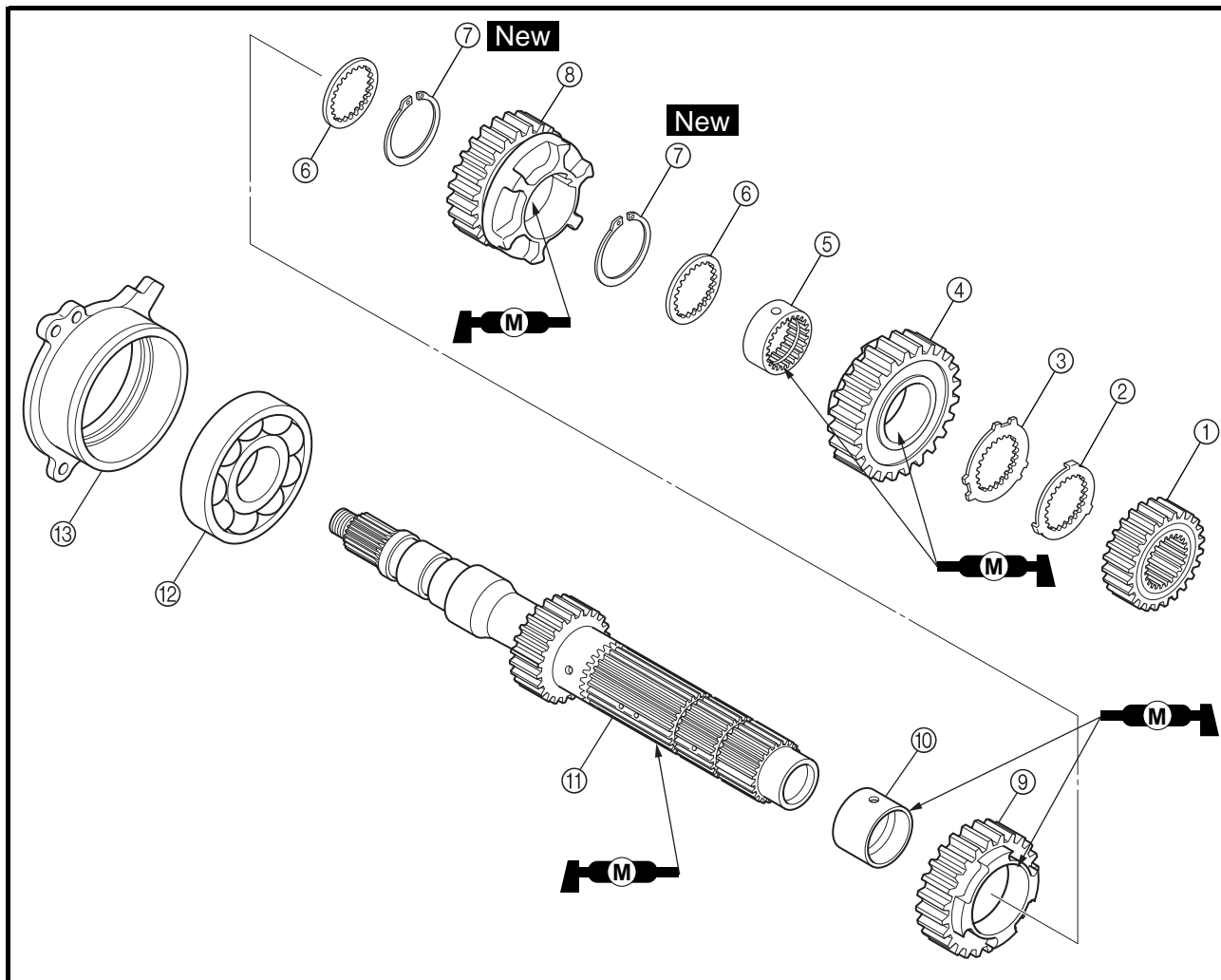

Order	Job/Part	Q'ty	Remarks
①	Main axle/1st pinion gear	1	For assembly, reverse the disassembly procedure.
⑫	Bearing	1	
⑬	Main axle bearing housing	1	

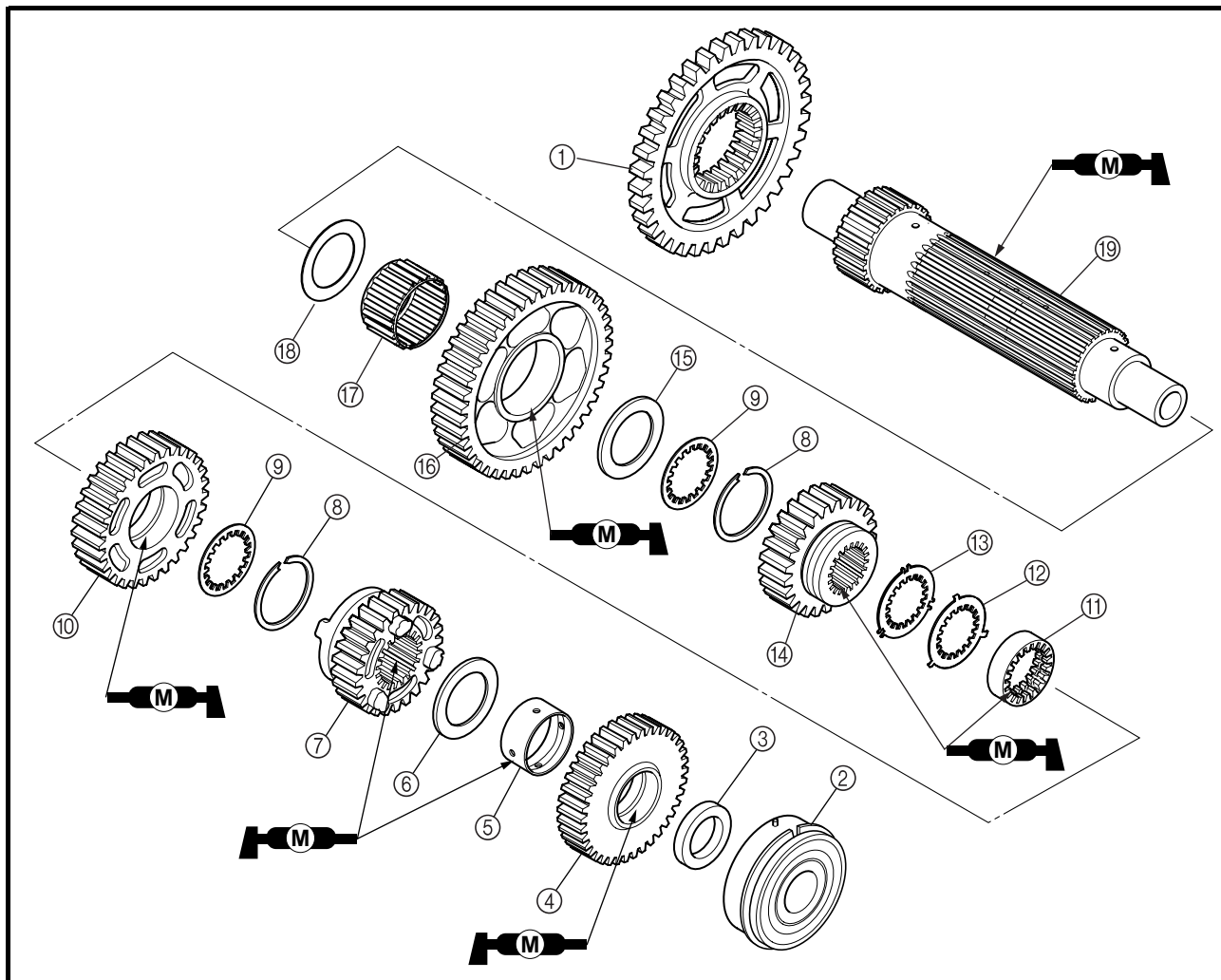

Order	Job/Part	Q'ty	Remarks
	Disassembling the drive axle assembly		Remove the parts in the order listed.
①	Middle drive gear	1	
②	Bearing	1	
③	Washer	1	
④	2nd wheel gear	1	
⑤	Collar	1	
⑥	washer	1	
⑦	5th wheel gear	1	
⑧	Circlip	2	
⑨	Toothed washer	2	
⑩	3rd wheel gear	1	

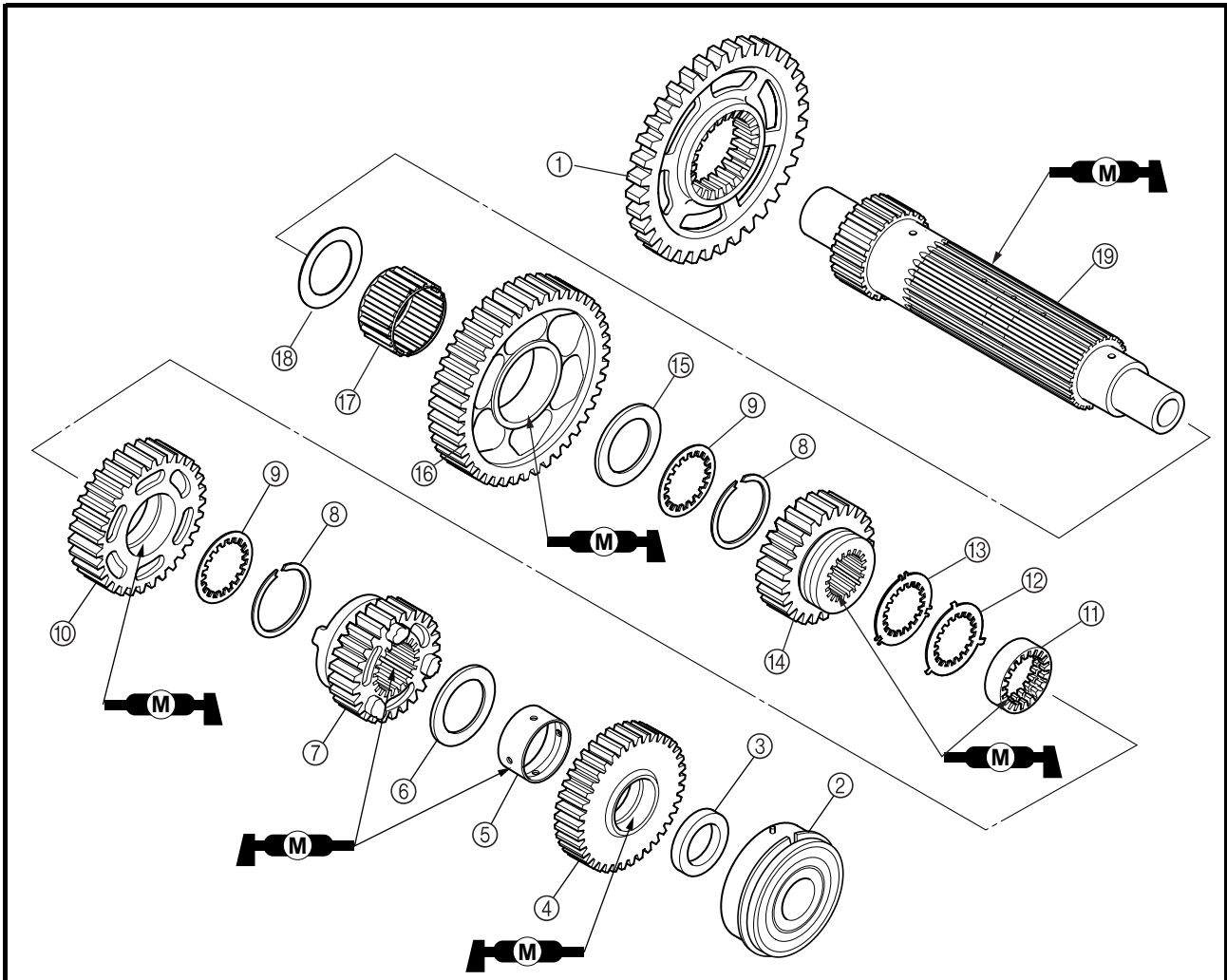

Order	Job/Part	Q'ty	Remarks
⑪	Toothed spacer	1	For assembly, reverse the disassembly procedure.
⑫	Toothed lock washer	1	
⑬	Toothed lock washer retainer	1	
⑭	4th wheel gear	1	
⑮	Washer	1	
⑯	1st wheel gear	1	
⑰	Bearing	1	
⑱	Washer	1	
⑲	Drive axle	1	

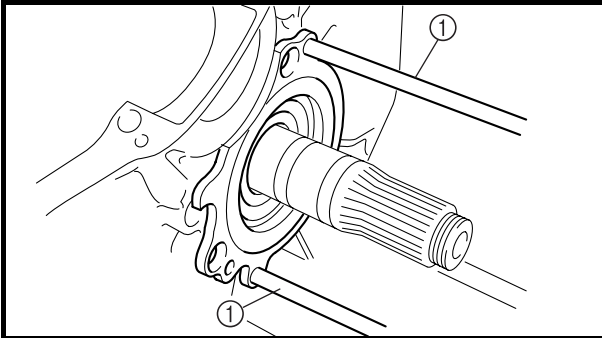
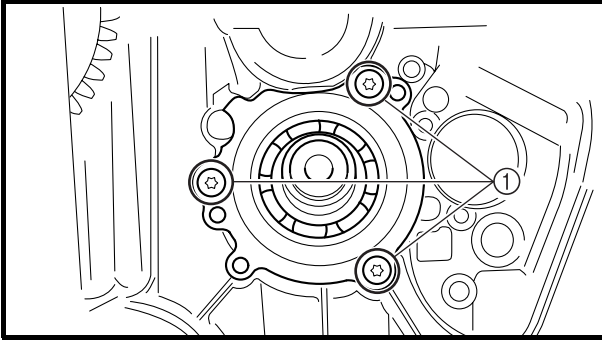

EAS00420

REMOVING THE TRANSMISSION

1. Remove:

- bearing housing bolts ①
(with the Torx wrench T30)

2. Remove:

- main axle assembly
(from the clutch side)

NOTE:

Remove the main axle assembly with the slide hammer bolt ① and weight.



Slide hammer bolt
90890-01083
Weight
90890-01084

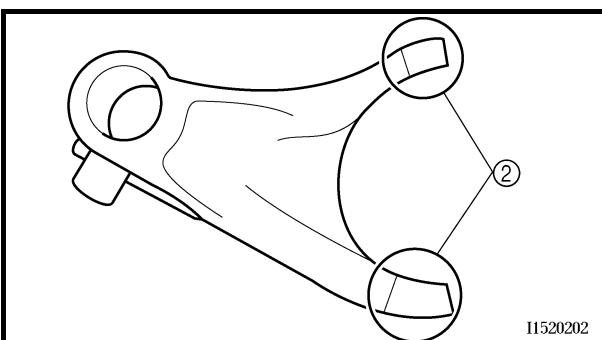
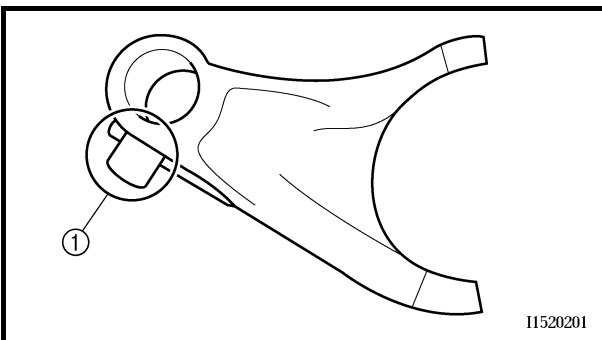

EAS00421

CHECKING THE SHIFT FORKS

The following procedure applies to all of the shift forks.

1. Check:

- shift fork cam follower ①
- shift fork pawl ②

Bends/damage/scoring/wear → Replace the shift fork.

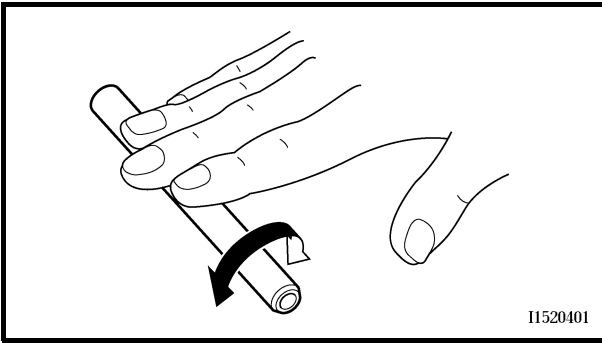

2. Check:

- shift fork guide bar
Roll the shift fork guide bar on a flat surface.
Bends → Replace.

⚠ WARNING

Do not attempt to straighten a bent shift fork guide bar.

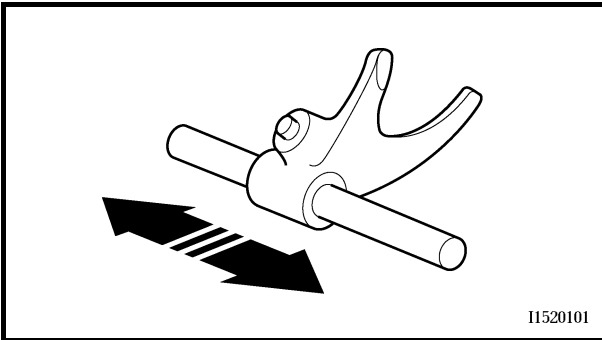

3. Check:

- shift fork movement
(along the shift fork guide bar)
Rough movement → Replace the shift forks and shift fork guide bar as a set.

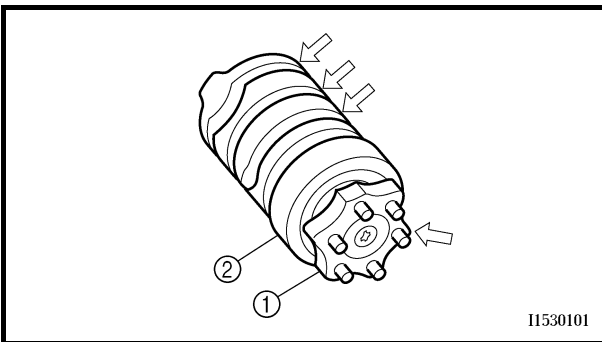

EAS00422

CHECKING THE SHIFT DRUM ASSEMBLY

1. Check:

- shift drum grooves
Damage/scratches/wear → Replace the shift drum assembly.
- shift drum segment ①
Damage/wear → Replace the shift drum assembly.
- shift drum bearing ②
Damage/pitting → Replace the shift drum assembly.

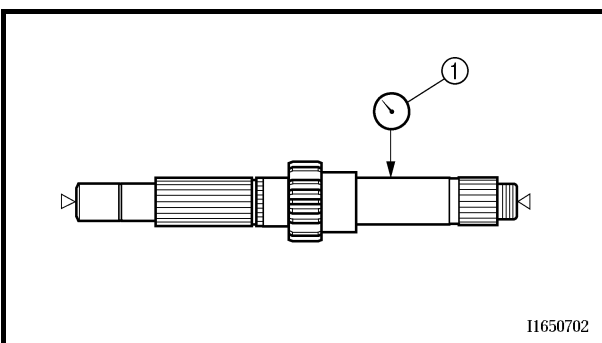

EAS00425

CHECKING THE TRANSMISSION

1. Measure:

- main axle runout
(with a centering device and dial gauge ①)
Out of specification → Replace the main axle.



**Main axle runout limit
0.08 mm**

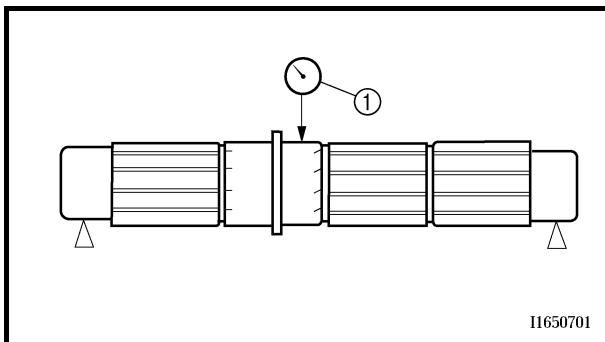

2. Measure:

- drive axle runout
(with a centering device and dial gauge ①)
Out of specification → Replace the drive axle.



Drive axle runout limit
0.08 mm

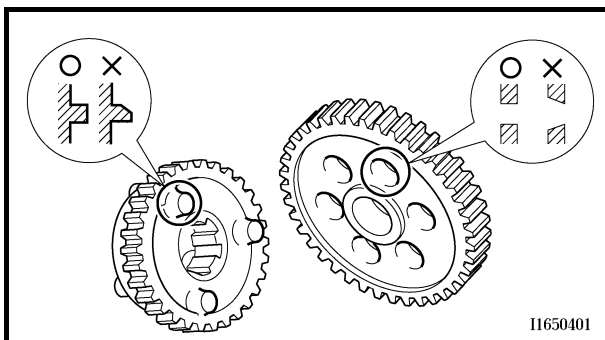

3. Check:

- transmission gears
Blue discoloration/pitting/wear → Replace the defective gear(s).
- transmission gear dogs
Cracks/damage/rounded edges → Replace the defective gear(s).

4. Check:

- transmission gear engagement
(each pinion gear to its respective wheel gear)
Incorrect → Reassemble the transmission axle assemblies.

5. Check:

- transmission gear movement
Rough movement → Replace the defective part(s).

6. Check:

- circlips
Bends/damage/looseness → Replace.



INSTALLING THE TRANSMISSION

1. Install:

- main axle assembly

 12 Nm (1.2 m · kg)

- shift fork "C"
- shift drum assembly
- shift fork "R"
- shift fork "L"
- shift fork guide bars
- shift drum retainer  10 Nm (1.0 m · kg)
- drive axle assembly

NOTE:

- When installing the main axle assembly, use a pin to align the bearing housing bolt hole with the corresponding hole in the upper crankcase.
- The embossed marks on the shift forks should face towards the right side of the engine and be in the following sequence: "R", "C", "L".
- Make sure the drive axle bearing circlip ① is inserted into the grooves ② in the upper crankcase.
- The drive axle bearing pin ② must face towards the rear of the crankcase.

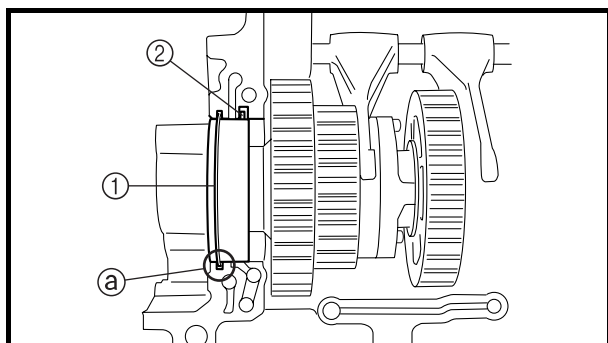

2. Check:

- transmission
Rough movement → Repair.

NOTE:

Oil each gear, shaft, and bearing thoroughly.



BALANCERS
FRONT BALANCER

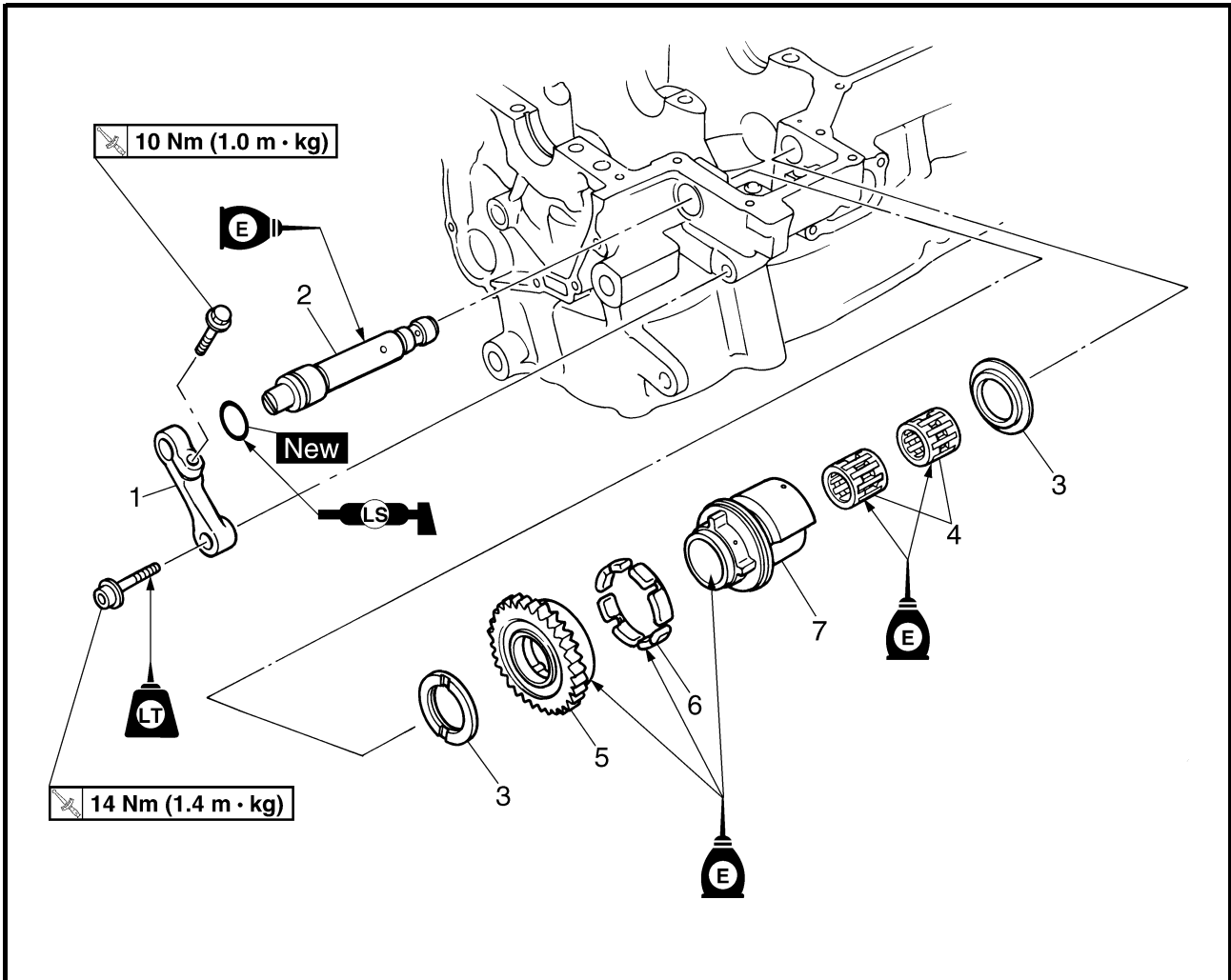

Order	Job/Part	Q'ty	Remarks
	Removing the front balancer		Remove the parts in the order listed.
	Crankcase		Separate. Refer to "CRANKCASE".
1	Balancer lever	1	Refer to "INSTALLING THE FRONT BALANCER".
2	Balancer shaft	1	
3	Washer	2	
4	Bearing	2	
5	Balancer gear	1	
6	Absorber	4	
7	Balancer weight	1	
			For installation, reverse the removal procedure.



REAR BALANCER

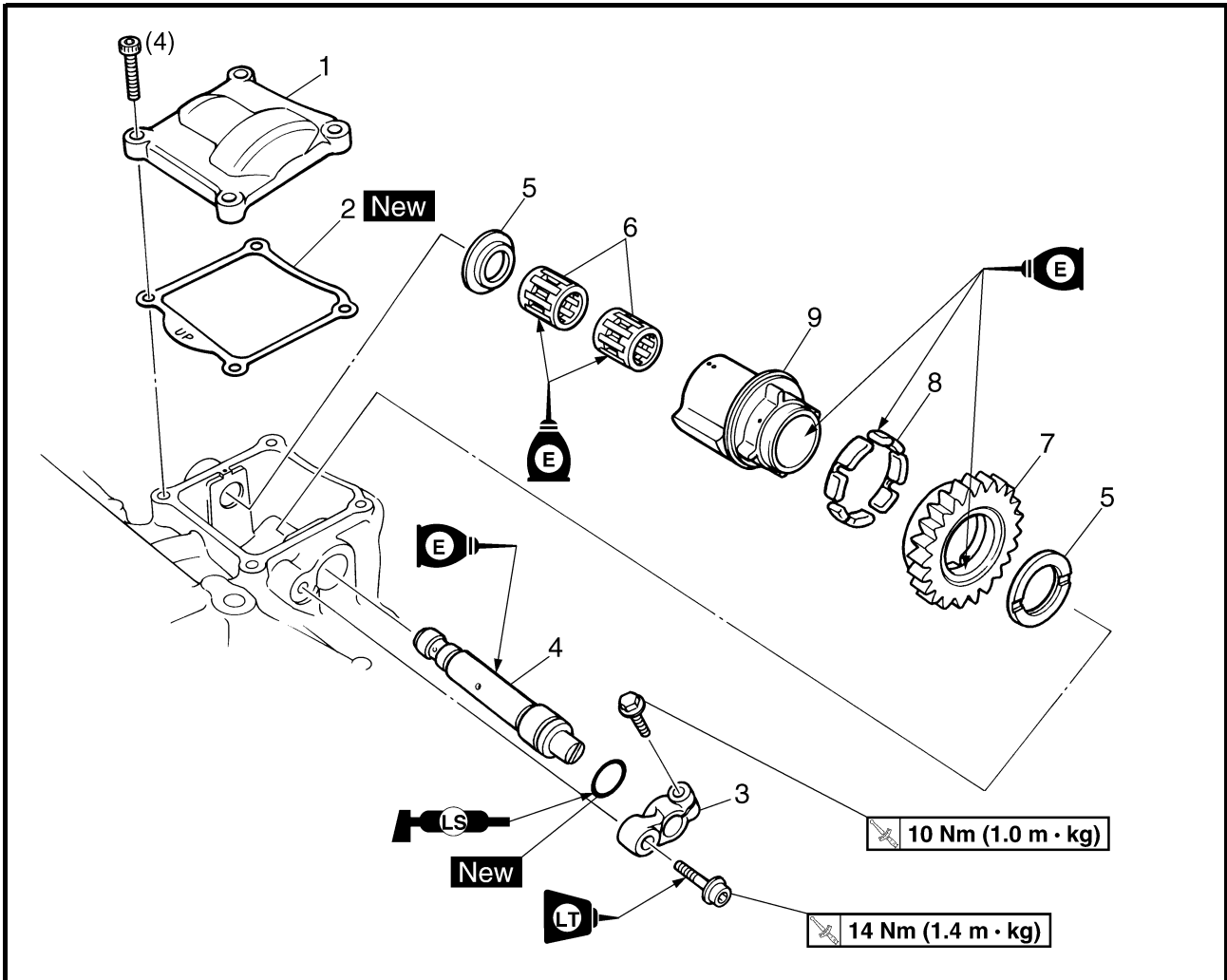

Order	Job/Part	Q'ty	Remarks
	Removing the rear balancer		Remove the parts in the order listed.
	Throttle bodies		Refer to "FUEL INJECTION SYSTEM" in chapter 7.
	Clutch cover		Refer to "CLUTCH".
1	Balancer cover	1	Refer to "INSTALLING THE REAR BALANCER".
2	Balancer cover gasket	1	
3	Balancer lever	1	
4	Balancer shaft	1	
5	Washer	2	
6	Bearing	2	
7	Balancer gear	1	
8	Absorber	4	
9	Balancer weight	1	
			For installation, reverse the removal procedure.

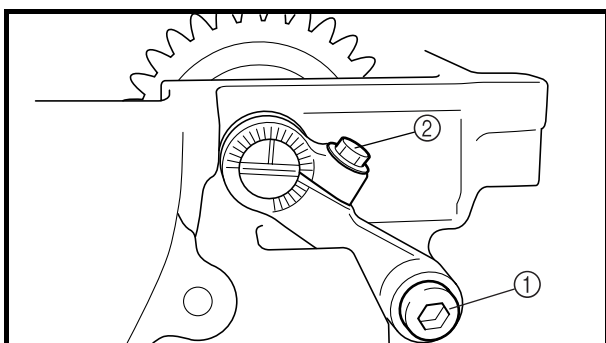
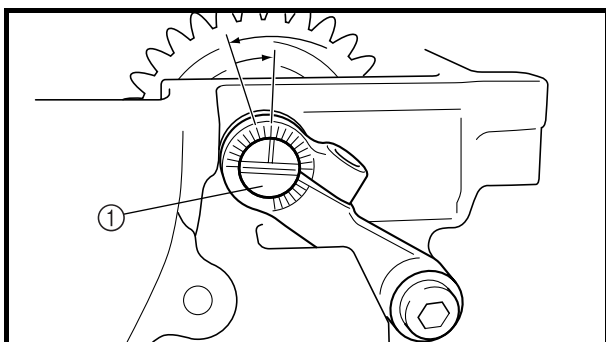
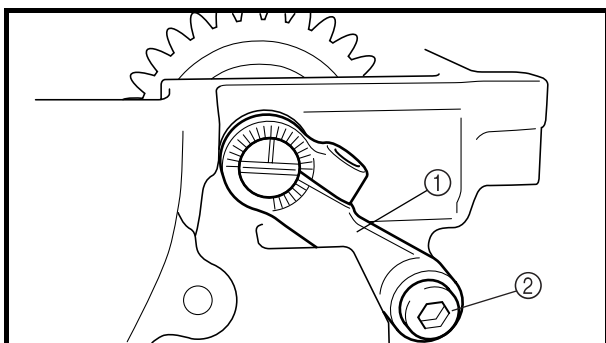
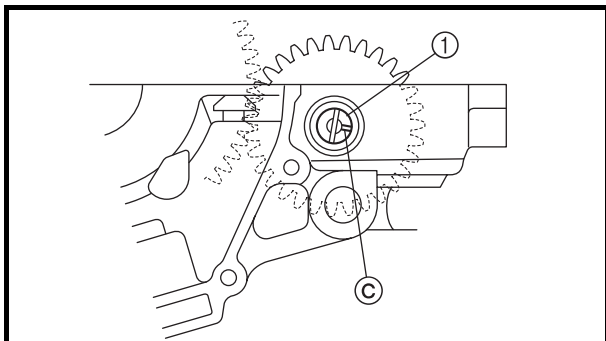
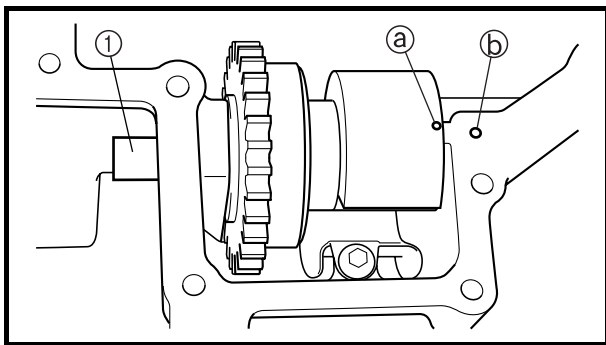

3. Install:

- balancer shaft ①

NOTE:

- Align the punch mark (a) in the balancer weight with the oil hole (b) in the upper crankcase.
- Make sure that the front balancer gear teeth and the primary drive gear teeth mesh correctly.
- Make sure that the slot (c) is facing in the direction indicated in the illustration when installing the balancer shaft.

4. Install:

- balancer lever ①
- balancer lever bolt ②

NOTE:

Temporarily tighten the balancer lever bolt.

5. Tighten:

- balancer shaft ①

NOTE:

Tighten the balancer shaft to the specified torque by turning it counterclockwise, and then turn it one scale back on the balancer lever scale.

6. Tighten:

- balancer lever bolt ①
- balancer shaft pinch bolt ②

NOTE:

Make sure that the balancer shaft does not rotate.

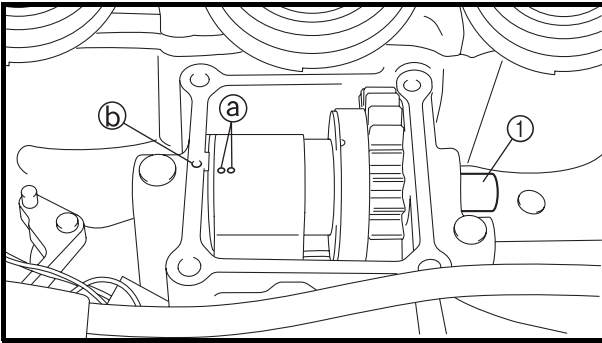

3. Install:

- balancer shaft ①

NOTE:

- Align the punch marks ③ in the balancer weight with the oil hole ② in the upper crankcase.
- Make sure that the rear balancer gear teeth and the primary driven gear teeth mesh correctly.
- Make sure that the balancer gear punch mark ④ is aligned with the primary driven gear point ⑤.
- Make sure that the slot ⑥ is facing in the direction indicated in the illustration when installing the balancer shaft.

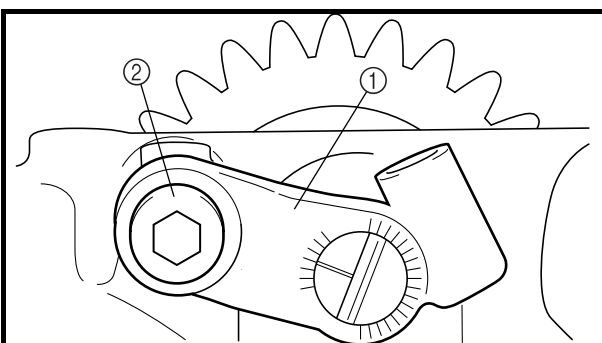
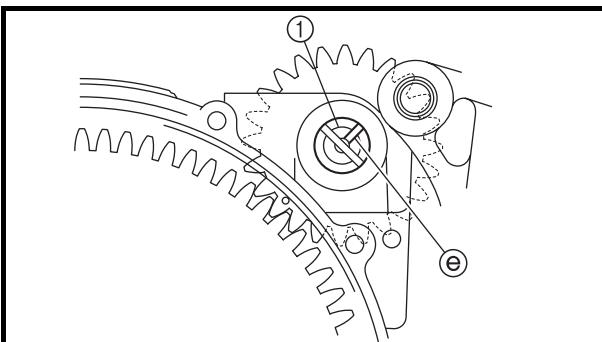
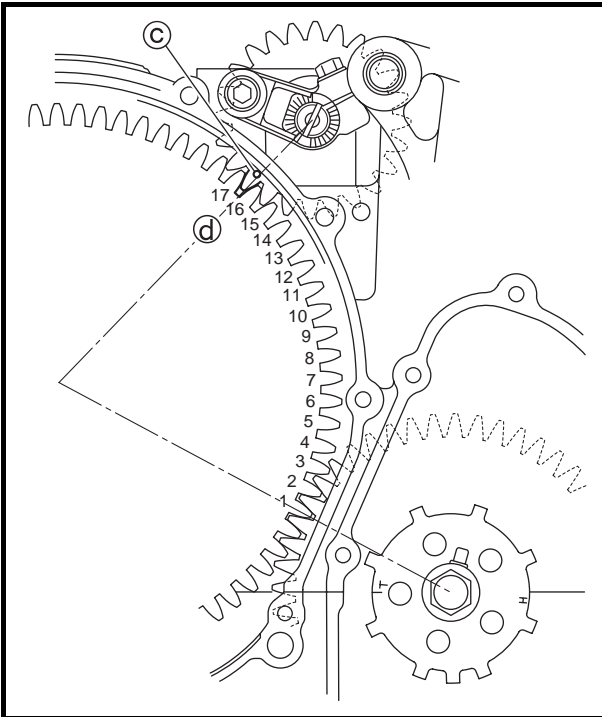

4. Install:

- balancer lever ①
- balancer lever bolt ② 

NOTE:

Temporarily tighten the balancer lever bolt.

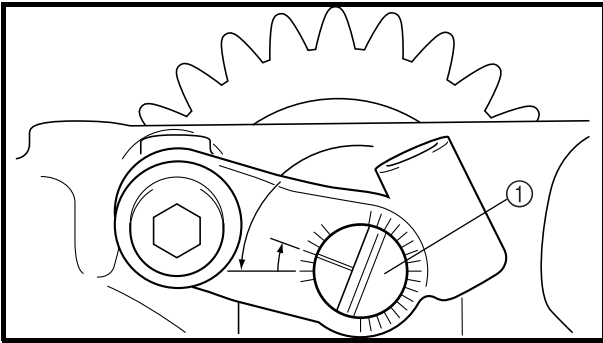

5. Tighten:

- balancer shaft ①

 **0.4 Nm (0.04 m · kg)**

NOTE:

Tighten the balancer shaft to the specified torque by turning it counterclockwise, and then turn it two scales back on the balancer lever scale.

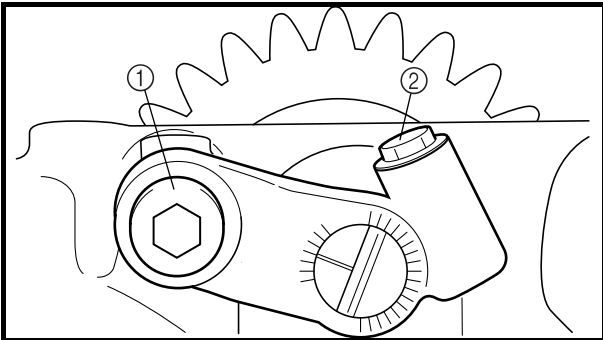

6. Tighten:

- balancer lever bolt ①

 **14 Nm (1.4 m · kg)**

- balancer shaft pinch bolt ②

 **10 Nm (1.0 m · kg)**

NOTE:

Make sure that the balancer shaft does not rotate.

7. Start the engine and check that there is no abnormal noise coming from the balancer gear. If noise is abnormal, adjust the gear lash by turning the balancer shaft.

NOTE:

With each adjustment, turn the balancer shaft one scale.

Clockwise	Decrease gear lash
Counterclockwise	Increase gear lash

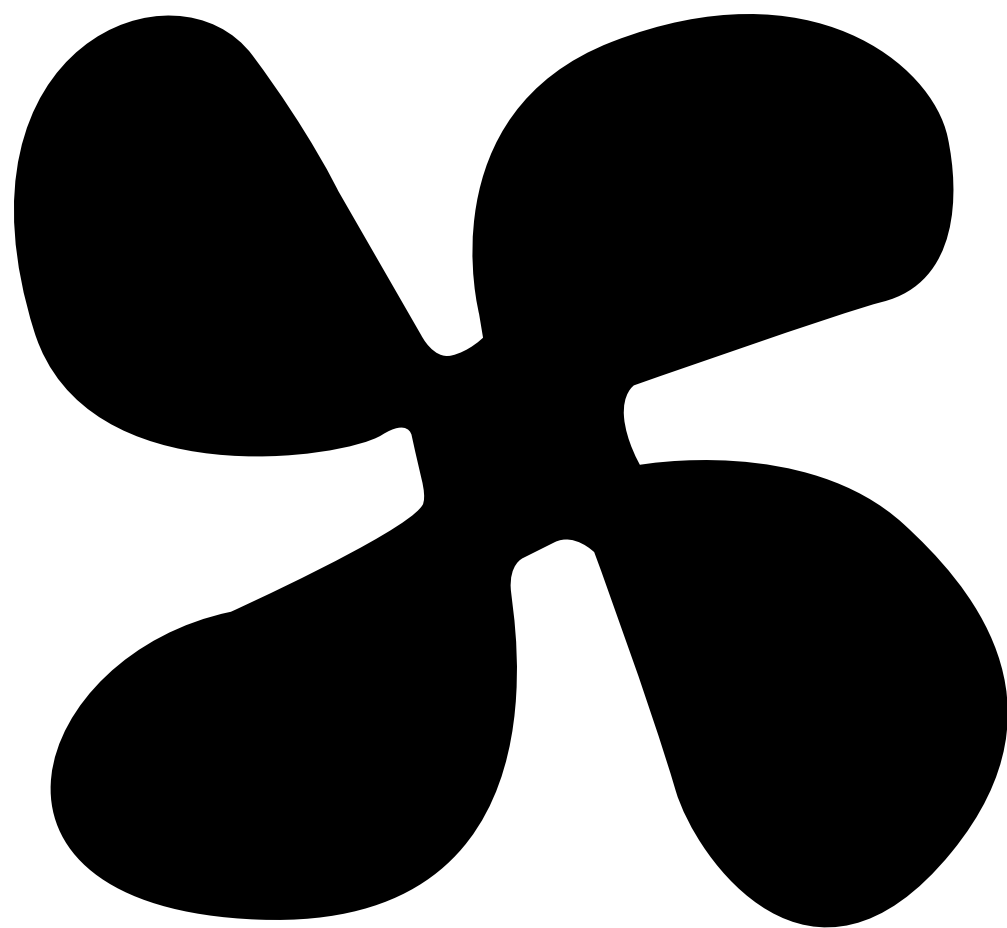

COOL

6

CHAPTER 6 COOLING SYSTEM

RADIATOR	6-1
CHECKING THE RADIATOR.....	6-3
INSTALLING THE RADIATOR.....	6-4
OIL COOLER	6-5
CHECKING THE OIL COOLER	6-6
INSTALLING THE OIL COOLER	6-6
THERMOSTAT	6-8
CHECKING THE THERMOSTAT.....	6-10
ASSEMBLING THE THERMOSTAT ASSEMBLY	6-11
INSTALLING THE THERMOSTAT ASSEMBLY	6-11
WATER PUMP	6-12
DISASSEMBLING THE WATER PUMP	6-15
CHECKING THE WATER PUMP	6-15
ASSEMBLING THE WATER PUMP.....	6-16
INSTALLING THE WATER PUMP	6-18

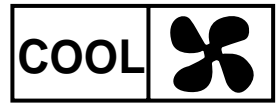

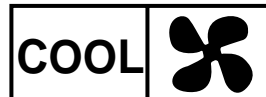

EAS00454

COOLING SYSTEM

RADIATOR

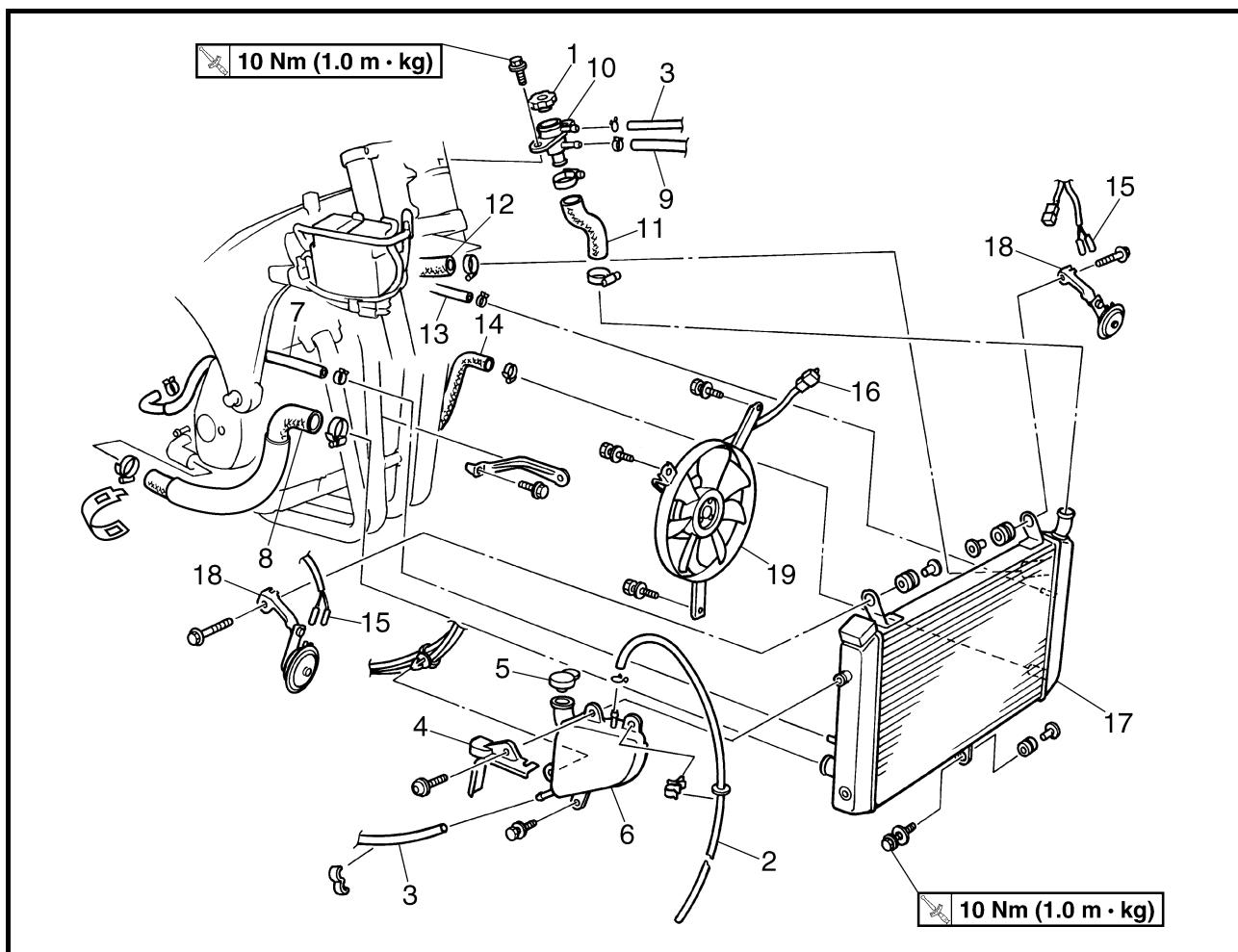

Order	Job/Part	Q'ty	Remarks
	Removing the radiator		Remove the parts in the order listed.
	Rider seat/fuel tank		Refer to "SEATS AND FUEL TANK" in chapter 3.
	Side cowlings/front cowling assembly		Refer to "COWLINGS AND COVERS" in chapter 3.
	Coolant		Drain. Refer to "CHANGING THE COOLANT" in chapter 3.
1	Radiator cap	1	
2	Coolant reservoir breather hose	1	
3	Coolant reservoir hose	1	
4	Coolant reservoir cap cover	1	
5	Coolant reservoir cap	1	
6	Coolant reservoir	1	
7	Water pump breather hose	1	

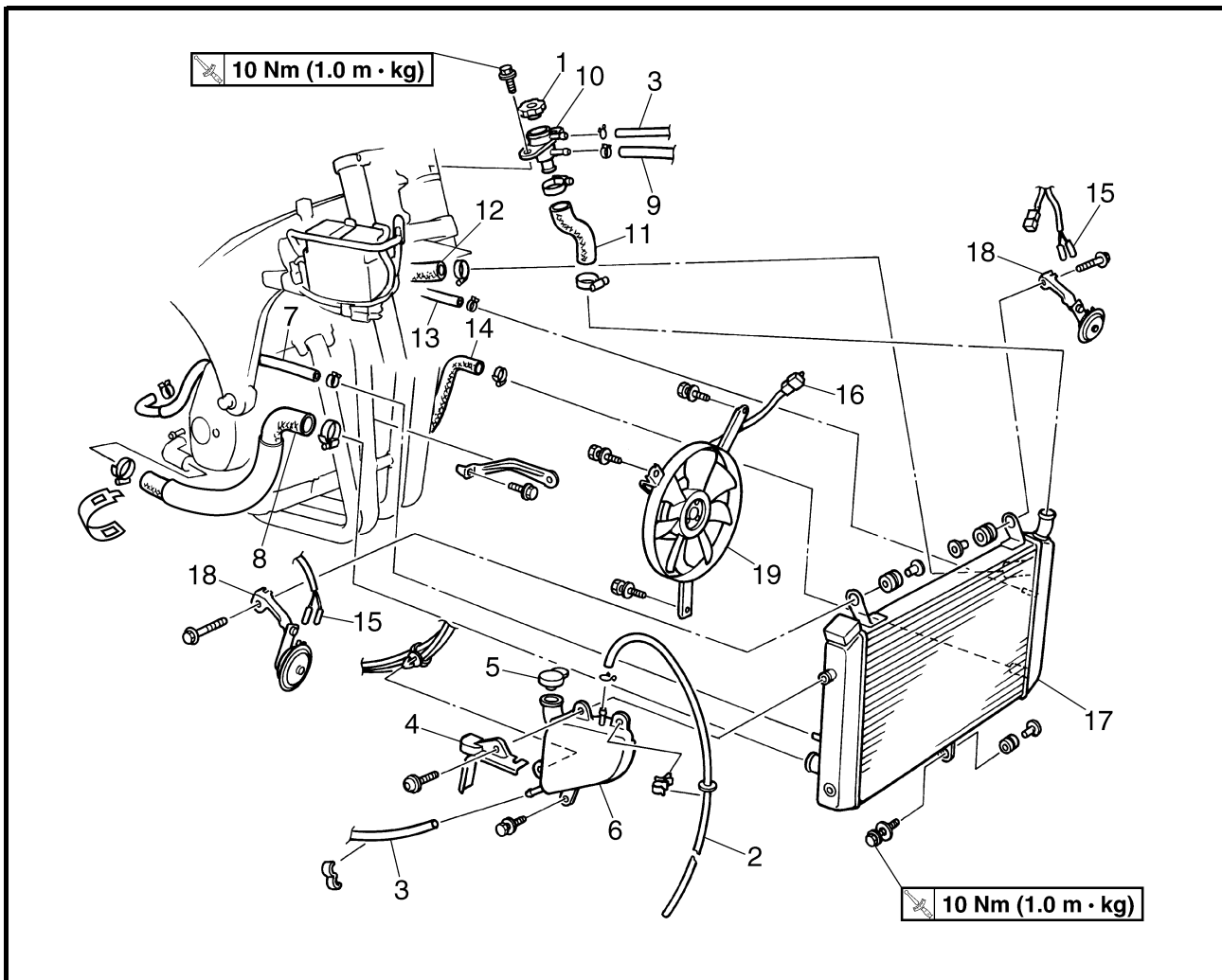

Order	Job/Part	Q'ty	Remarks
8	Radiator outlet hose	1	
9	Thermostat assembly breather hose	1	Disconnect.
10	Conduit	1	
11	Conduit hose	1	
12	Radiator inlet hose	1	Disconnect.
13	Plunger control unit hose 2	1	Disconnect.
14	Oil cooler outlet hose	1	Disconnect.
15	Horn connector	4	Disconnect.
16	Radiator fan motor coupler	1	Disconnect.
17	Radiator	1	
18	Horn bracket (left and right)	2	
19	Radiator fan	1	
			For installation, reverse the removal procedure.

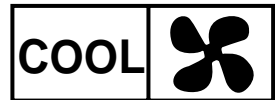

EAS00456

INSTALLING THE RADIATOR

1. Fill:

- cooling system
(with the specified amount of the recommended coolant)
Refer to "CHANGING THE COOLANT" in chapter 3.

2. Check:

- cooling system
Leaks → Repair or replace any faulty part.

3. Measure:

- radiator cap opening pressure
Below the specified pressure → Replace the radiator cap.
Refer to "CHECKING THE RADIATOR".

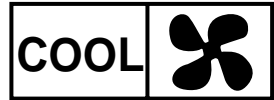

EAS00457

OIL COOLER

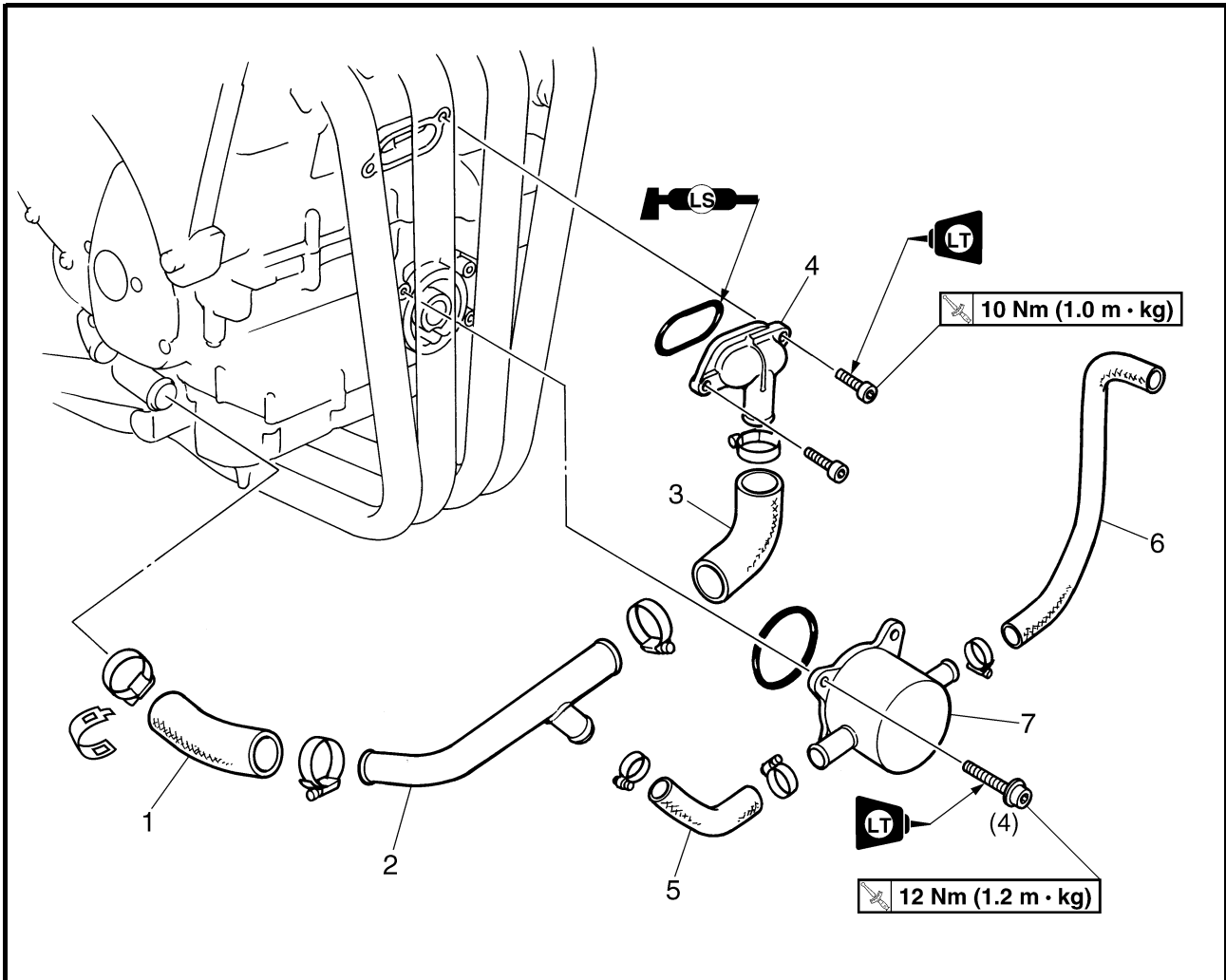

Order	Job/Part	Q'ty	Remarks
	Removing the oil cooler		Remove the parts in the order listed.
	Engine oil		Drain. Refer to "CHANGING THE ENGINE OIL" in chapter 3.
	Radiator assembly		Refer to "RADIATOR".
1	Water pump outlet hose	1	
2	Water pump outlet pipe	1	
3	Water jacket joint inlet hose	1	
4	Water jacket joint	1	
5	Oil cooler inlet hose	1	
6	Oil cooler outlet hose	1	
7	Oil cooler	1	
			For installation, reverse the removal procedure.

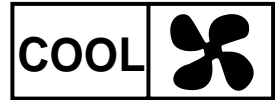

EAS00458

CHECKING THE OIL COOLER

1. Check:
 - oil cooler
Cracks/damage → Replace.
2. Check:
 - oil cooler inlet hose
 - oil cooler outlet hose
Cracks/damage/wear → Replace.

EAS00459

INSTALLING THE OIL COOLER

1. Clean:
 - mating surfaces of the oil cooler and the crankcase
(with a cloth dampened with lacquer thinner)

2. Install:
 - O-ring **New**
 - oil cooler  **12 Nm (1.2 m · kg)**

NOTE:

Make sure the O-ring is positioned properly.

3. Fill:
 - cooling system
(with the specified amount of the recommended coolant)
Refer to “CHANGING THE COOLANT” in chapter 3.
 - crankcase
(with the specified amount of the recommended engine oil)
Refer to “CHANGING THE ENGINE OIL” in chapter 3.

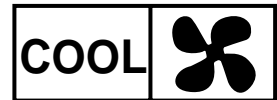

4. Check:
 - cooling system
Leaks → Repair or replace any faulty part.
5. Measure:
 - radiator cap opening pressure
Below the specified pressure → Replace the radiator cap.
Refer to "CHECKING THE RADIATOR".

EAS00460

THERMOSTAT

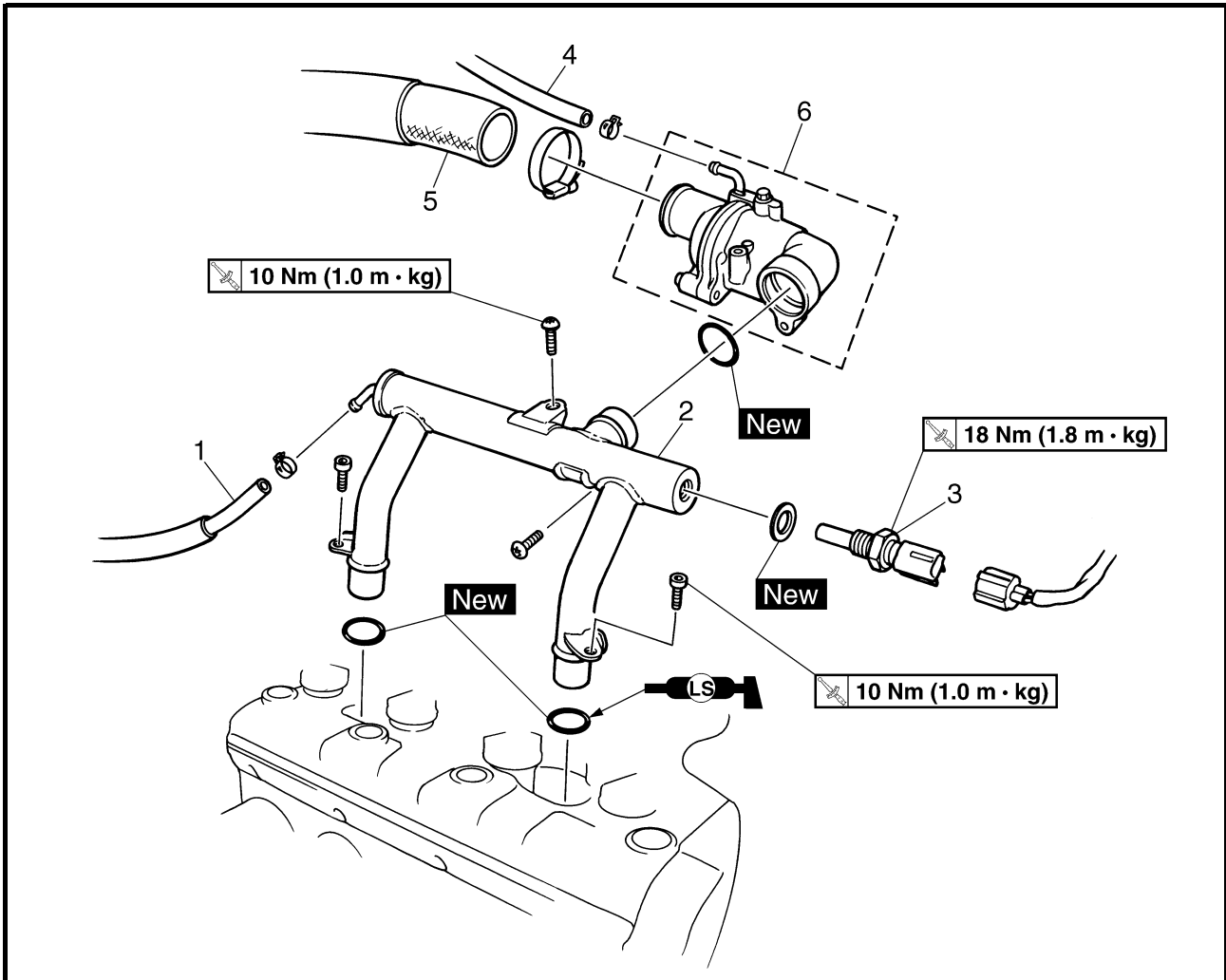

Order	Job/Part	Q'ty	Remarks
	Removing the thermostat assembly		Remove the parts in the order listed.
	Side cowlings/front cowling assembly		Refer to "COWLINGS AND COVERS" in chapter 3.
	Coolant		Drain. Refer to "CHANGING THE COOLANT" in chapter 3.
	Air cut-off valve assembly/hoses		Refer to "AIR INDUCTION SYSTEM" in chapter 7.
1	Plunger control unit hose 1	1	Disconnect.
2	Thermostat assembly inlet pipe	1	
3	Coolant temperature sensor	1	
4	Thermostat assembly breather hose	1	Disconnect.
5	Radiator inlet hose	1	Disconnect.
6	Thermostat assembly	1	
			For installation, reverse the removal procedure.

EAS00461

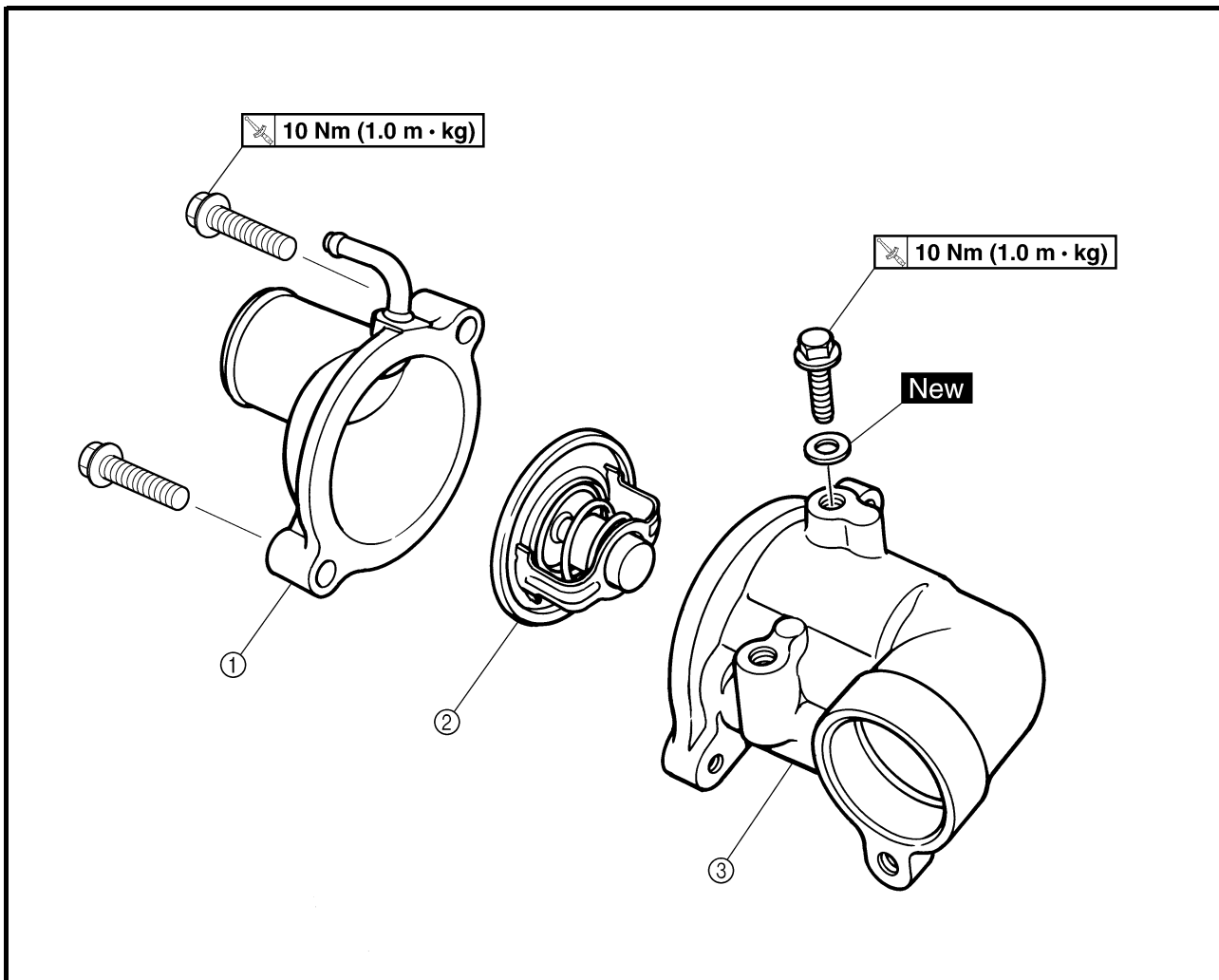

Order	Job/Part	Q'ty	Remarks
	Disassembling the thermostat assembly		Remove the parts in the order listed.
①	Thermostat housing cover	1	Refer to "ASSEMBLING THE THERMOSTAT ASSEMBLY".
②	Thermostat	1	
③	Thermostat housing	1	
			For assembly, reverse the disassembly procedure.

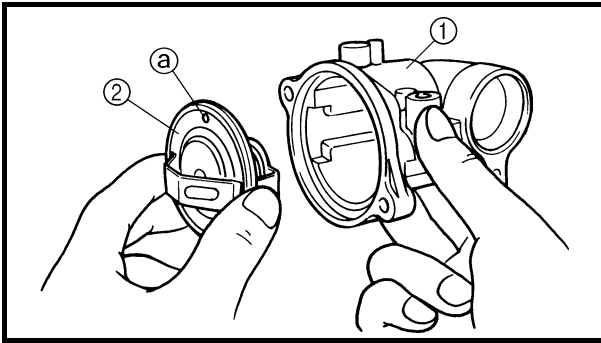

EAS00464

ASSEMBLING THE THERMOSTAT ASSEMBLY

1. Install:
 - thermostat housing ①
 - thermostat ②
 - thermostat housing cover

NOTE: _____
 Install the thermostat with its breather hole (a) facing up.

EAS00466

INSTALLING THE THERMOSTAT ASSEMBLY

1. Lubricate:
 - O-ring (thermostat assembly and thermostat assembly inlet pipe)

	Recommended lubricant LLC
---	--------------------------------------

2. Fill:
 - cooling system
 (with the specified amount of the recommended coolant)
 Refer to “CHANGING THE COOLANT” in chapter 3.

3. Check:
 - cooling system
 Leaks → Repair or replace any faulty part.
4. Measure:
 - radiator cap opening pressure
 Below the specified pressure → Replace the radiator cap.
 Refer to “CHECKING THE RADIATOR”.

EAS00468

WATER PUMP

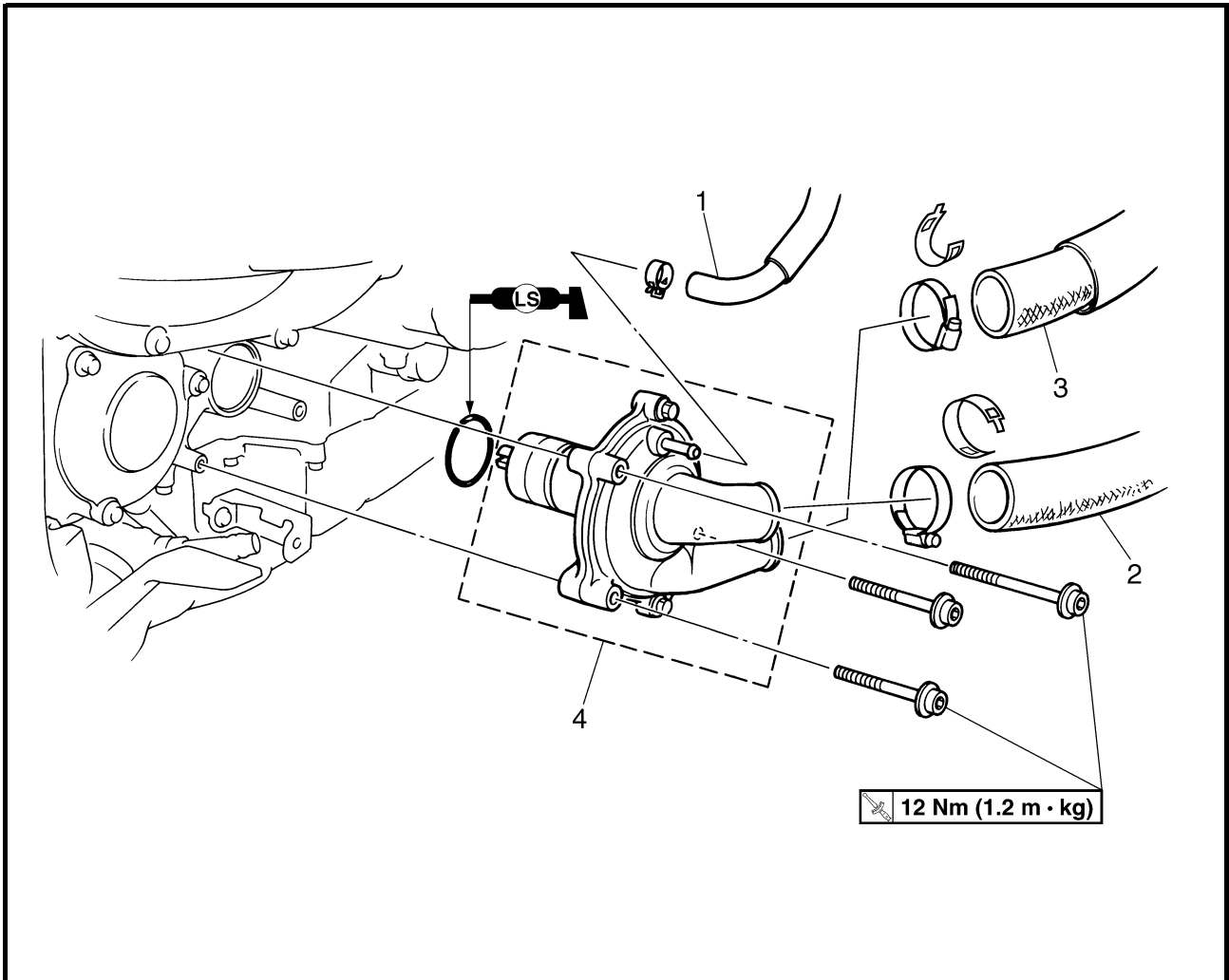

Order	Job/Part	Q'ty	Remarks
	Removing the water pump		Remove the parts in the order listed. NOTE: _____ It is not necessary to remove the water pump unless the coolant level is extremely low or the coolant contains engine oil. _____
	Right side cowling		Refer to "COWLINGS AND COVERS" in chapter 3.
	Engine oil		Drain. Refer to "CHANGING THE ENGINE OIL" in chapter 3.
	Coolant		Drain. Refer to "CHANGING THE COOLANT" in chapter 3.

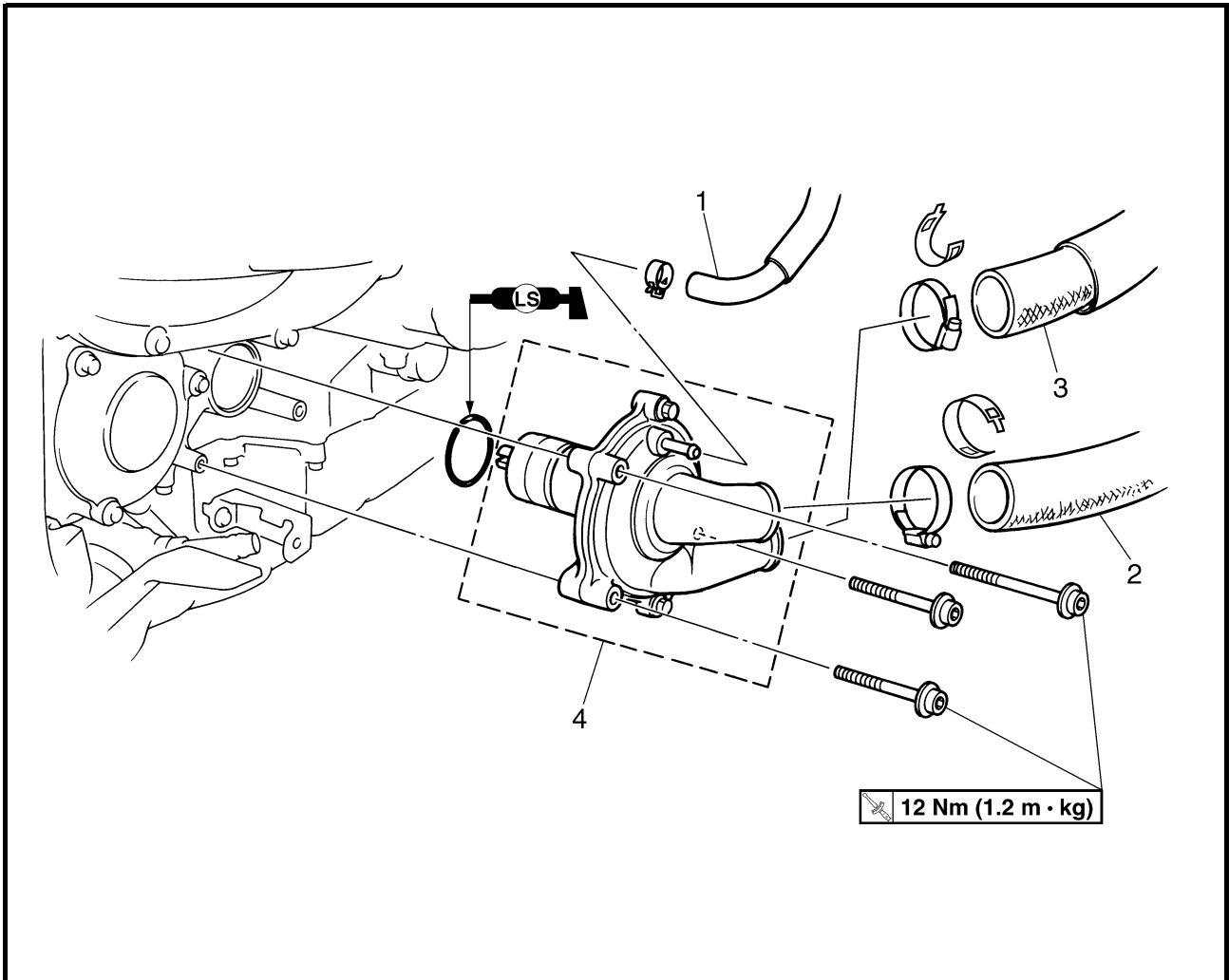

Order	Job/Part	Q'ty	Remarks
1	Water pump breather hose	1	Disconnect.
2	Radiator outlet hose	1	Disconnect.
3	Water pump outlet hose	1	Disconnect.
4	Water pump	1	Refer to "INSTALLING THE WATER PUMP". For installation, reverse the removal procedure.

EAS00469

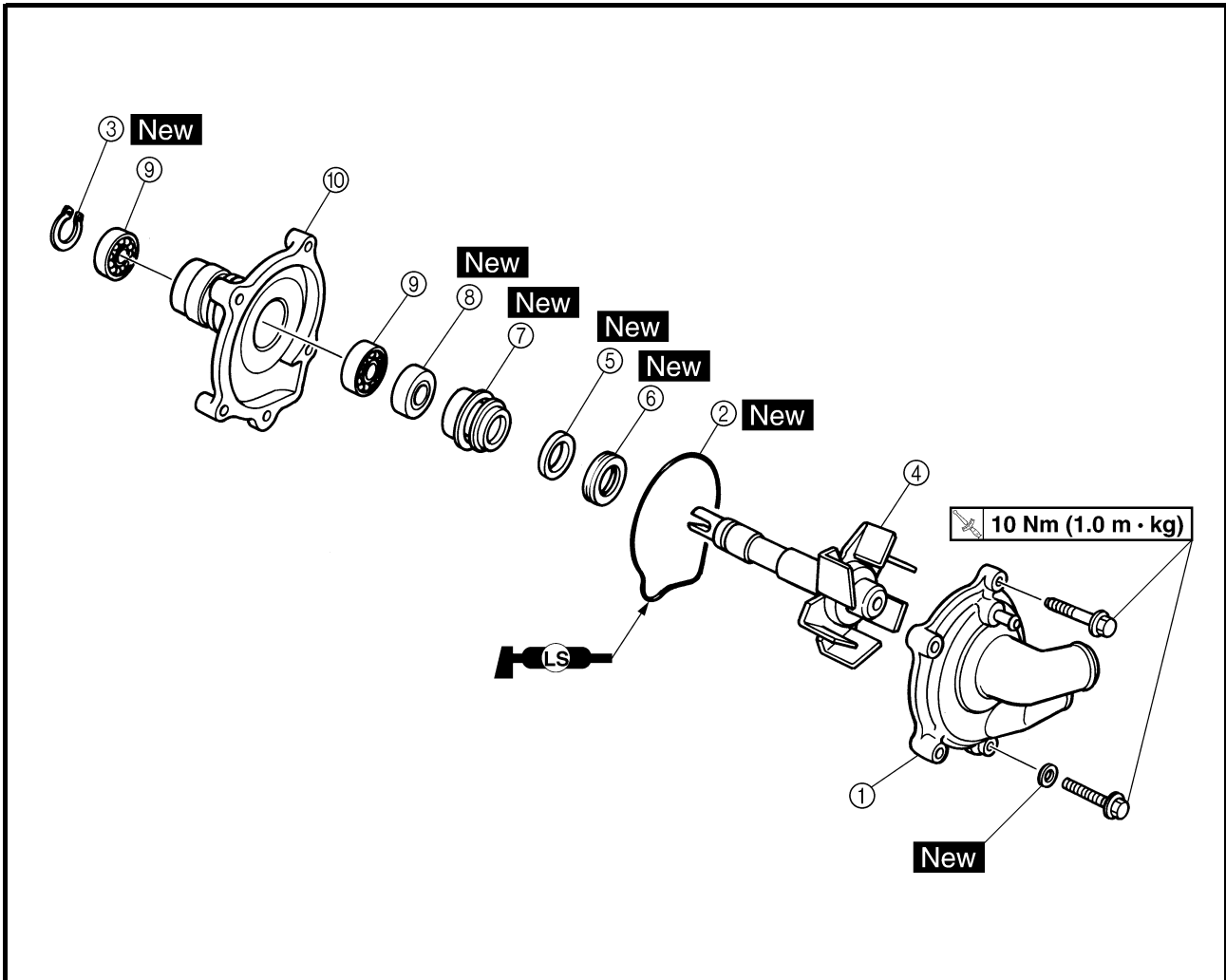

Order	Job/Part	Q'ty	Remarks
	Disassembling the water pump		Remove the parts in the order listed.
①	Water pump housing cover	1	Refer to "ASSEMBLING THE WATER PUMP".
②	O-ring	1	
③	Circlip	1	
④	Impeller shaft	1	
⑤	Rubber damper holder	1	
⑥	Rubber damper	1	
⑦	Water pump seal	1	
⑧	Oil seal	1	
⑨	Bearing	2	
⑩	Water pump housing	1	
			For assembly, reverse the disassembly procedure.

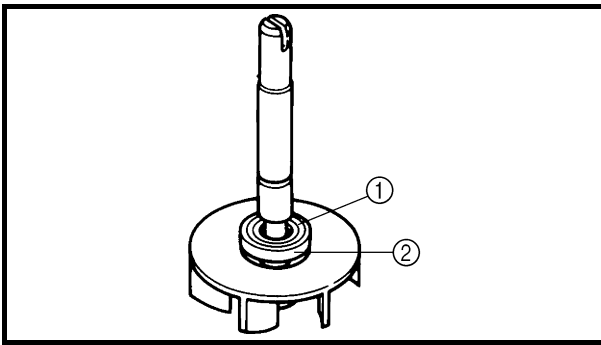

EAS00470

DISASSEMBLING THE WATER PUMP

1. Remove:

- rubber damper holder ①
- rubber damper ②
(from the impeller, with a thin, flat-head screwdriver)

NOTE:

Do not scratch the impeller shaft.

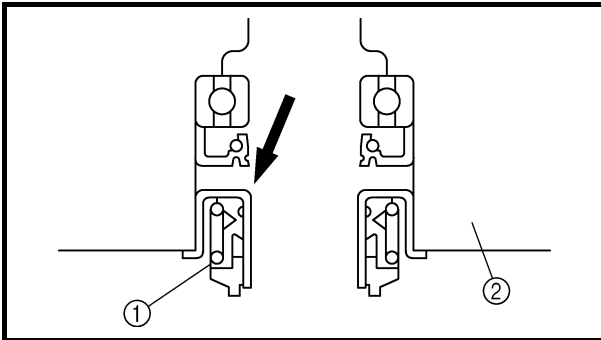

2. Remove:

- water pump seal ①

NOTE:

Tap out the water pump seal from the inside of the water pump housing ②.

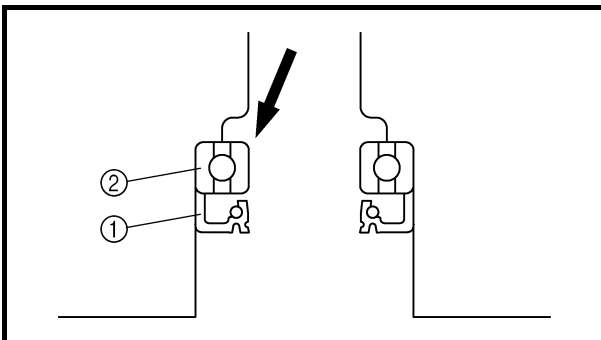

3. Remove:

- oil seal ①
- bearing ②

NOTE:

Tap out the bearing and oil seal from the outside of the water pump housing.

EAS00473

CHECKING THE WATER PUMP

1. Check:

- water pump housing cover
 - water pump housing
 - impeller
 - rubber damper
 - rubber damper holder
 - water pump seals
 - oil seal
- Cracks/damage/wear → Replace.

2. Check:

- bearing
- Rough movement → Replace.

3. Check:

- water pump outlet pipe
 - radiator outlet hose
- Cracks/damage/wear → Replace.

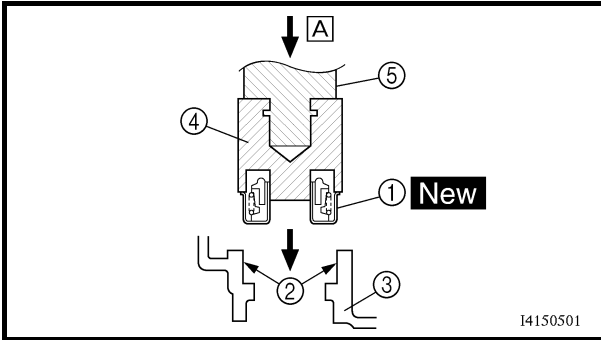
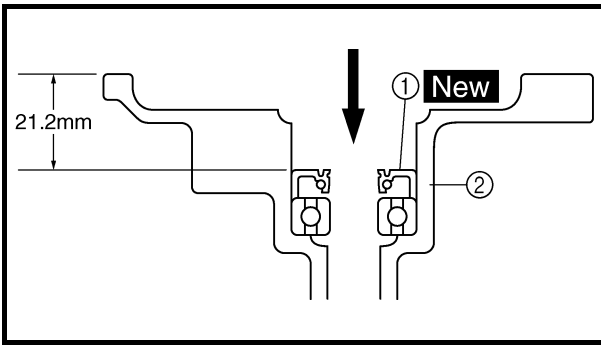
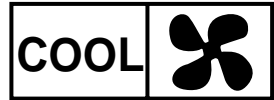

EAS00475

ASSEMBLING THE WATER PUMP

1. Install:

- oil seal ① **New**
(into the water pump housing ②)

NOTE:

- Before installing the oil seal, apply tap water or coolant onto its out surface.
- Install the oil seal with a socket that matches its outside diameter.

2. Install:

- water pump seal ① **New**

CAUTION:

Never lubricate the water pump seal surface with oil or grease.

NOTE:

- Install the water pump seal with the special tools.
- Before installing the water pump seal, apply Yamaha bond No.1215 ② to the water pump housing ③.



Mechanical seal installer

90890-04078 ④

Middle driven shaft bearing driver

90890-04058 ⑤

Yamaha bond #1215

90890-85505

A Push down.

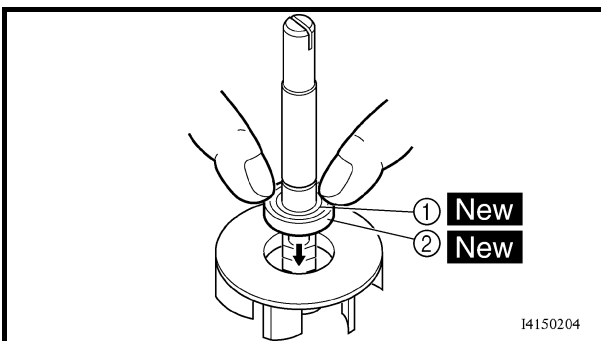

3. Install:

- rubber damper ① **New**
- rubber damper holder ② **New**

NOTE:

Before installing the rubber damper, apply tap water or coolant onto its outer surface.

WATER PUMP

COOL

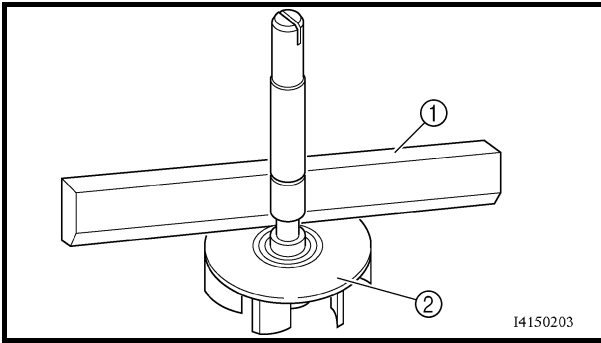

4. Measure:

- impeller shaft tilt
Out of specification → Repeat steps (3) and (4).

CAUTION:

Make sure the rubber damper and rubber damper holder are flush with the impeller.



Max. impeller shaft tilt
0.15 mm

- ① Straightedge
- ② Impeller

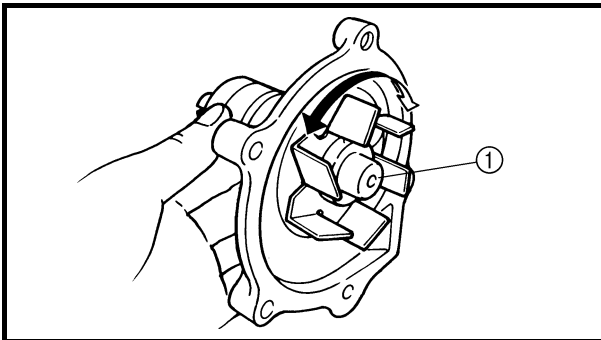

5. Install:

- impeller ①
- circlip **New**

NOTE:

After installation, check that the impeller shaft rotates smoothly.

6. Install:

- O-ring **New**

NOTE:

Lubricate the O-ring with a thin coat of lithium soap base grease.

7. Install:

- water pump housing
- water pump housing cover

10 Nm (1.0 m · kg)

⚠ WARNING

Always use a new copper washer.

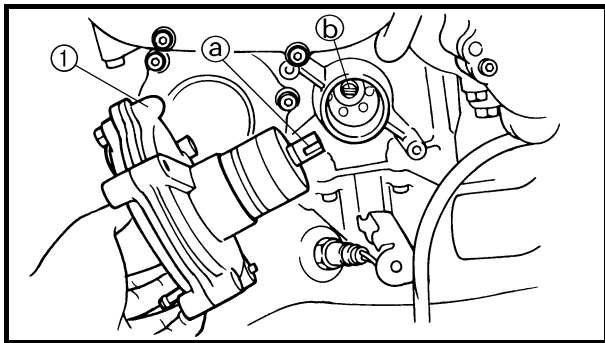

EAS00478

INSTALLING THE WATER PUMP

1. Install:

- O-ring **New**
- water pump assembly ①

	12 Nm (1.2 m · kg)
---	---------------------------

⚠ WARNING

- **Align the slit ① on the impeller shaft with the projection ② on the oil pump shaft.**
- **Lubricate the O-ring with a thin coat of lithium soap base grease.**

2. Fill:

- cooling system
(with the specified amount of the recommended coolant)
Refer to "CHANGING THE COOLANT" in chapter 3.
- crankcase
(with the specified amount of the recommended engine oil)
Refer to "CHANGING THE ENGINE OIL" in chapter 3.

3. Check:

- cooling system
Leaks → Repair or replace the faulty part.

4. Measure:

- radiator cap opening pressure
Below the specified pressure → Replace the radiator cap.
Refer to "CHECKING THE RADIATOR".



FI





CHAPTER 7

FUEL INJECTION SYSTEM

FUEL INJECTION SYSTEM	7-1
WIRING DIAGRAM	7-2
ECU'S SELF-DIAGNOSTIC FUNCTION.....	7-3
SUBSTITUTE CHARACTERISTICS OPERATION CONTROL (FAIL-SAFE ACTION)	7-7
TROUBLESHOOTING	7-8
THROTTLE BODIES.....	7-33
CHECKING THE INJECTOR	7-37
CHECKING THE THROTTLE BODY	7-37
CHECKING THE PRESSURE REGULATOR	7-37
CHECKING THE FUEL PUMP AND PRESSURE REGULATOR OPERATION	7-38
AIR INDUCTION SYSTEM	7-40
AIR INJECTION.....	7-40
AIR CUT-OFF VALVE	7-40
AIR INDUCTION SYSTEM DIAGRAMS.....	7-41
AIR CUT-OFF VALVE ASSEMBLY AND AIR INDUCTION SYSTEM HOSES	7-42
REED VALVES.....	7-43
CHECKING THE AIR INDUCTION SYSTEM.....	7-44

FI



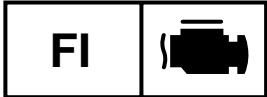

FUEL INJECTION SYSTEM

FUEL INJECTION SYSTEM

- | | | | |
|-----------------------------|------------------------------|----------------------------------|--------------------------------|
| ① Ignition coil | ⑧ Intake air pressure sensor | ⑭ Coolant temperature sensor | ⑳ Atmospheric pressure sensor |
| ② Air filter case | ⑨ Throttle position sensor | ⑮ Spark plug | ㉑ Fuel injection system relay |
| ③ Intake temperature sensor | ⑩ Fuel injector | ⑯ Cylinder identification sensor | ㉒ Engine trouble warning light |
| ④ Fuel delivery hose | ⑪ O ₂ sensor | ⑰ Pressure regulator | ㉓ Lean angle cut-off switch |
| ⑤ Fuel tank | ⑫ Catalytic converter | ⑱ Battery | ㉔ Air cut-off valve |
| ⑥ Fuel pump | ⑬ Crankshaft position sensor | | |
| ⑦ Fuel return hose | | | |

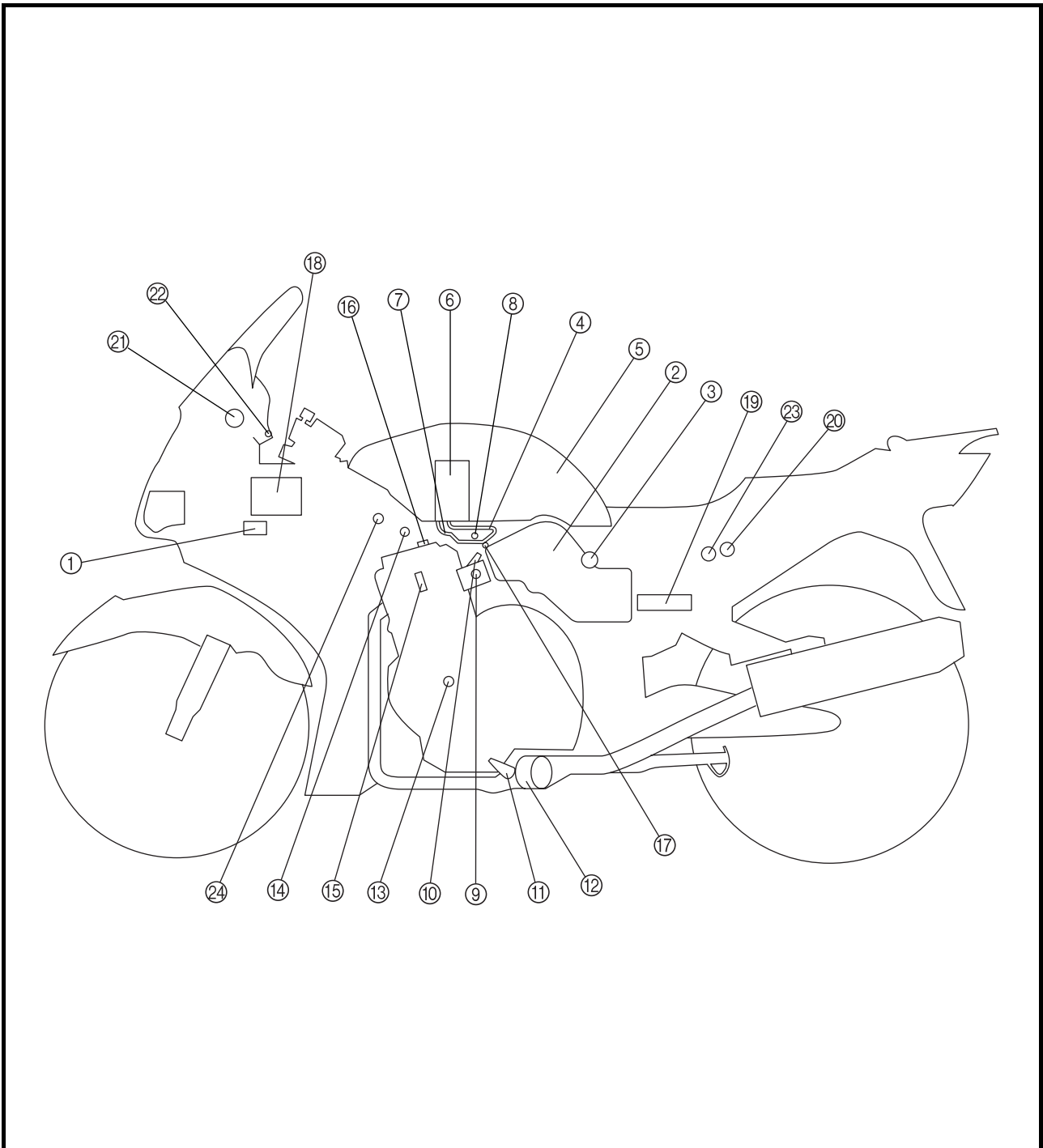



WIRING DIAGRAM

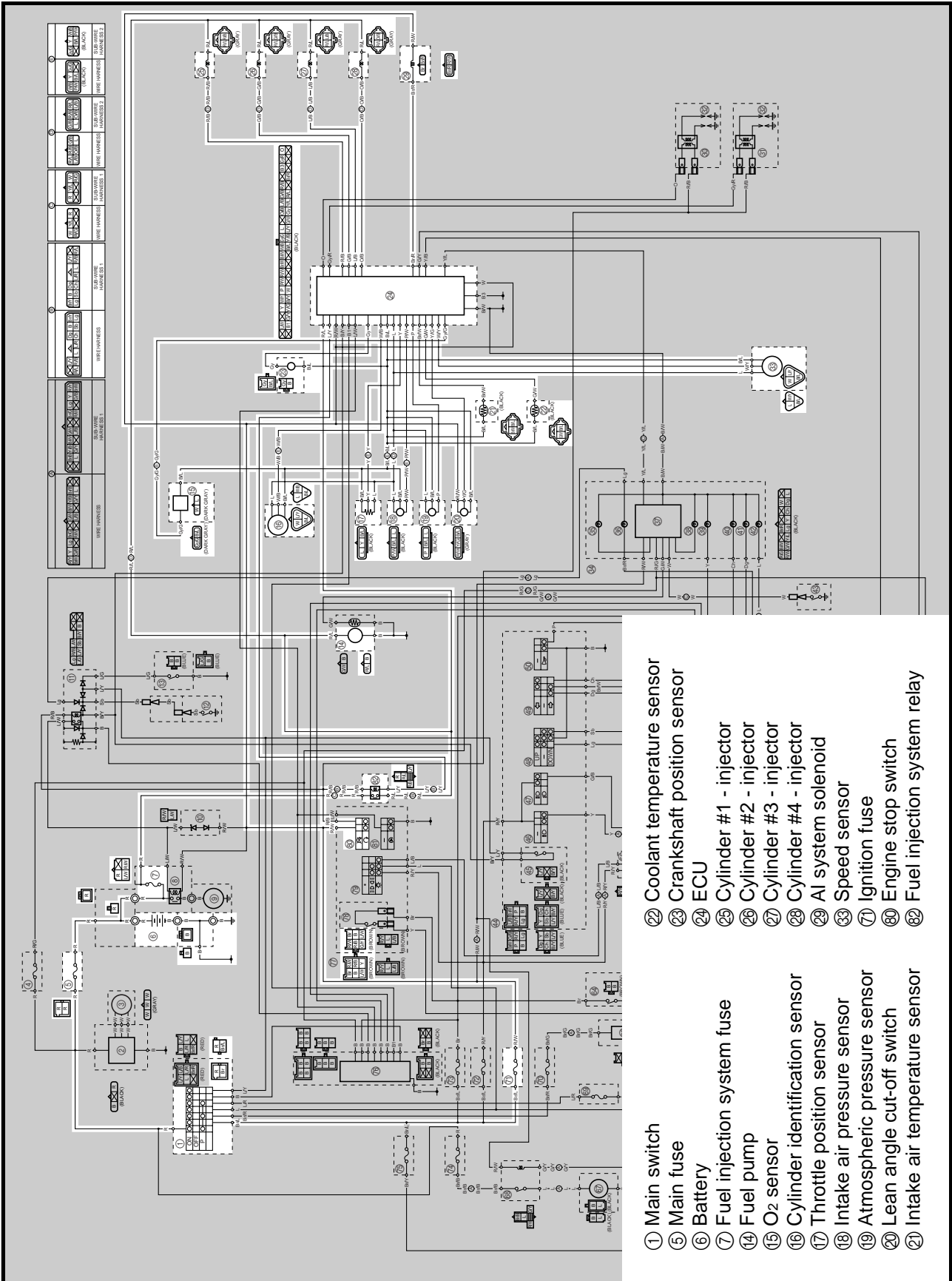

- ① Main switch
- ⑤ Main fuse
- ⑥ Battery
- ⑦ Fuel injection system fuse
- ⑭ Fuel pump
- ⑮ O₂ sensor
- ⑰ Cylinder identification sensor
- ⑱ Throttle position sensor
- ⑳ Intake air pressure sensor
- ㉑ Atmospheric pressure sensor
- ㉒ Lean angle cut-off switch
- ㉓ Intake air temperature sensor
- ㉔ Coolant temperature sensor
- ㉕ Crankshaft position sensor
- ㉖ ECU
- ㉗ Cylinder #1 - injector
- ㉘ Cylinder #2 - injector
- ㉙ Cylinder #3 - injector
- ㉚ Cylinder #4 - injector
- ㉛ AI system solenoid
- ㉜ Speed sensor
- ㉝ Ignition fuse
- ㉞ Engine stop switch
- ㉟ Fuel injection system relay



ECU'S SELF-DIAGNOSTIC FUNCTION

The ECU is equipped with a self-diagnostic function in order to ensure that the engine control system is operating normally. If this function detects a malfunction in the system, it immediately operates the engine under substitute characteristics and illuminates the engine trouble warning light to alert the rider that a malfunction has occurred in the system. Once a malfunction has been detected, it becomes stored in the ECU memory in the form of a fault code.

ECU's mode function

The ECU is equipped with a diagnosis mode, in addition to the normal mode in which the ECU operates normally.

Normal mode

- To check whether the warning light bulb is blown, the warning light illuminates for 1.4 seconds after the main switch has been turned ON, and while the starter switch is being pressed.
- To inform the rider that the fuel injection stop function is active, the warning light blinks while the start switch is being pressed to start the engine.
- If a malfunction in the system is detected by the self-diagnostic function, this mode provides an appropriate substitute characteristic operation, and alerts the rider of the detected malfunction by illuminating a warning light.
- After the engine has been stopped, digital numbers representing the self-diagnostic fault codes appear on the clock LCD. Once a self-diagnostic fault code has been displayed, it remains stored in the ECU memory until a deletion operation is performed.

Diagnosis mode

- In this mode, diagnostic codes are input into the ECU in accordance with the number of times the start switch has been operated.
- In accordance with the diagnostic codes, the ECU displays the values received from the sensors and actuates the actuators.
- Whether or not the system is operating normally is determined by a human operator through the observations of the values indicated by the engine trouble warning light or the actuating conditions of the actuators.

FUEL INJECTION SYSTEM

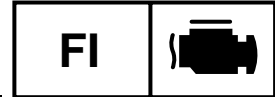

Engine trouble warning light indication and FI system operating conditions (normal mode)

Warning light indication	ECU's operating condition	FI operating condition	Starting and driving
ON and OFF *1	Self-diagnostic function in operation	FI function in operation	Able
Blinking *2	Warning control when unable to start engine	Operation stopped	Unable
Continuous ON	Detecting malfunction	Gives driving instructions with substitute characteristics in accordance with the description of the malfunction.	Able/Unable depending on self-diagnostic fault code
OFF *3	Possibly a blown warning light bulb or a malfunction in power supply system or ECU		

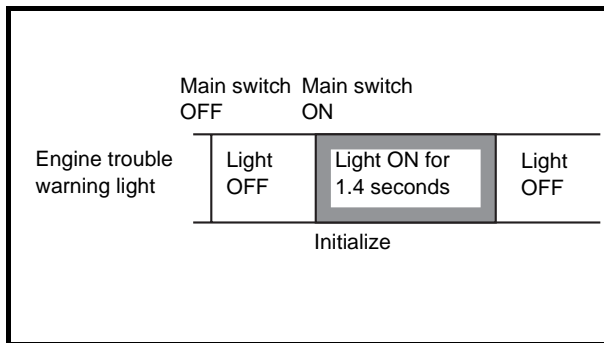

*1

The warning light illuminates 1.4 seconds each time the main switch is turned ON. The ECU performs a self diagnosis during this time and turns OFF the light thereafter.

*2

Warning control when unable to start engine
This control is effected when any one of the conditions listed below is present and the starter switch is turned ON:

- a. Battery voltage below the specified value (defective Fuel injection system relay, engine stop switch turned OFF, or drained battery)
- b. One of the fault codes listed below has been detected (self-diagnostic code 12, 19, 30, 33, 34, 41, or 50 is output):
 - (12: faulty crankshaft position sensor signal)
 - (19: open circuit in sidestand input line)
 - (30: a fall has been detected)
 - (33, 34: faulty ignition)
 - (41: open or short circuit in lean angle cut-off switch)
 - (50: ECU memory check error)

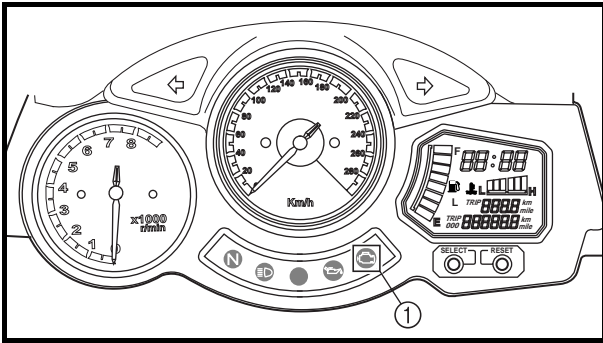
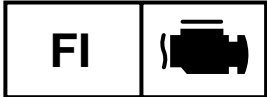

*3

Function to check for blown warning light bulb
 The engine trouble warning light illuminates ① for 1.4 seconds after the main switch has been turned “ON” and while the starter switch is being pressed. If the warning light does not illuminate under these conditions, a problem may have possibly occurred, such as a blown warning light bulb. Therefore, take an appropriate corrective action by referring to the troubleshooting section.

Determining the area of the malfunction through the self-diagnostic fault code number

The possible location of the system in which a problem may be occurring can be determined by observing the self-diagnostic fault code number that appears on the multi-function meter and cross-referencing it on the fault code number table. When used in conjunction with the troubleshooting details, and by checking the possible items one by one, you will be able to identify the cause of the problem in order to carry out an accurate repair work.

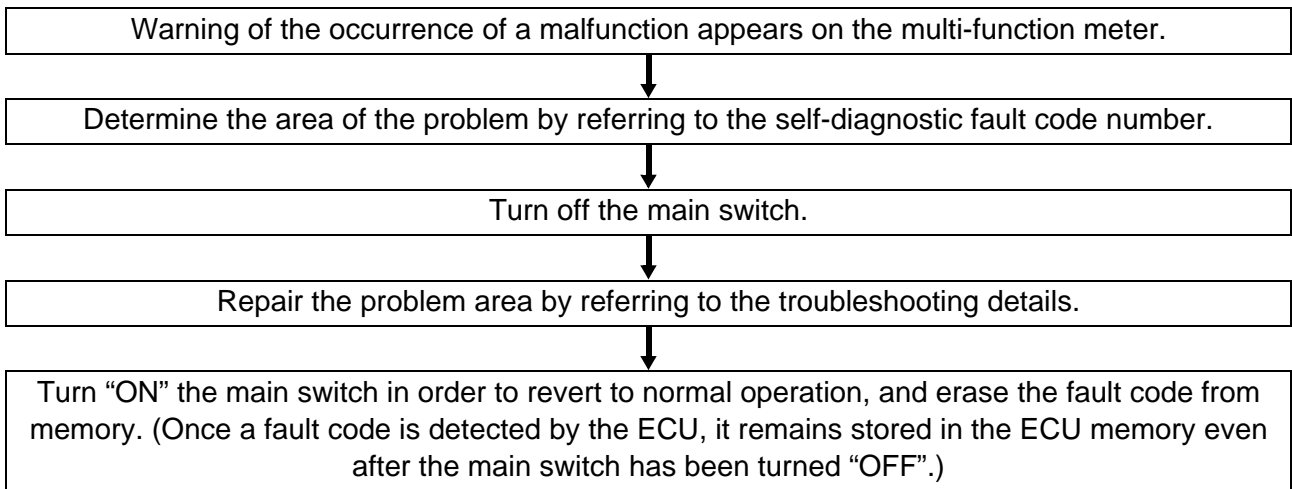

FUEL INJECTION SYSTEM

FI

* Table of self-diagnostic fault code numbers displayed on meter

No.	Symptom	Able/ unable to start	Able/ unable to drive	No.	Symptom	Able/ unable to start	Able/ unable to drive
11	No normal signals are received from the cylinder identification sensor.	Able	Able	30	The motorcycle has overturned.	Unable	Unable
12	No normal signals are received from the crankshaft position sensor.	Unable	Unable	31	The amount of air-fuel ratio feedback compensation is maintained continuously in the vicinity of the upper limit (lean air-fuel ratio).	Able	Able
13	Intake air pressure sensor - open or short circuit detected.	Able	Able	32	The amount of air-fuel ratio feedback compensation is maintained continuously in the vicinity of the lower limit (rich air-fuel ratio).	Able	Able
14	Faulty intake air pressure sensor pipe system; a hose is detached, causing the constant application of atmospheric pressure to the sensor; or, the hose is clogged.	Able	Able	33	Open circuit detected in the primary wire of the ignition coil (#1,4).	Able	Able
15	Throttle position sensor - open or short circuit detected.	Able	Able	34	Open circuit detected in the primary wire of the ignition coil (#2, 3).	Able	Able
16	A stuck throttle position sensor is detected.	Able	Able	41	Lean angle cut-off switch - open or short circuit detected.	Unable	Unable
19	Open circuit is detected in the input line from the sidestand switch to the ECU.	Unable	Unable	42	No normal signals are received from the speed sensor; or, an open or short circuit is detected in the neutral switch.	Able	Able
21	Coolant temperature sensor - open or short circuit detected.	Able	Able	43	The ECU is unable to monitor the battery voltage (an open circuit in the line to the ECU).	Able	Able
22	Intake temperature sensor - open or short circuit detected.	Able	Able	44	An error is detected while reading or writing on EEPROM (CO adjustment value).	Able	Able
23	Atmospheric pressure sensor - open or short circuit detected.	Able	Able	50	Faulty ECU memory. When this malfunction is detected, the code number might not appear on the meter.	Unable	Unable
24	No normal signals are received from the O ₂ sensor.	Able	Able				

- How to erase the self-diagnostic fault code from memory:

If the ECU detects a normal signal upon the completion of the repair of the malfunction, the self-diagnostic fault code disappears from the meter and is replaced by the normal clock display. However, the self-diagnostic fault code of the previous malfunction remains in the ECU memory as part of the malfunction history. To erase the self-diagnostic fault code from the malfunction history, the operation for diagnostic code 62 must be performed in the diagnosis mode.



SUBSTITUTE CHARACTERISTICS OPERATION CONTROL (FAIL-SAFE ACTION)

If the ECU detects an abnormal signal from a sensor while the motorcycle is being driven, the ECU illuminates the engine trouble warning light and provides the engine with substitute characteristic operation instructions that are appropriate for the type of the malfunction.

When an abnormal signal is received from a sensor, the ECU processes the specified values that are programmed for every sensor, in order to provide the engine with substitute characteristics operation instructions that enable the engine to continue to operate (or to stop its operation, depending on circumstances).

The ECU takes fail-safe actions in two ways: one in which the sensor output is set to a prescribed value, and the other in which the ECU directly operates an actuator. Details on the fail-safe actions are given in the table below.

Table of substitute characteristic operation control by self-diagnostic fault code

Code No.	Item	Fail-safe action	Able/unable to start	Able/unable to drive
11	Cylinder identification sensor	Continues to operate the engine based on the results of the cylinder identification that existed up to that point.	Able	Able
12	Crankshaft position sensor	• Stops the engine (by stopping the injection and ignition).	Unable	Unable
13 14	Intake air pressure sensor (open or short circuit) (pipe system)	• Fixes the intake air pressure to 760 mmHg.	Able	Able
15 16	Throttle position sensor (open or short circuit) (stuck)	• Fixes the throttle position sensor to fully open.	Able	Able
19	Sidestand switch (open circuit in wire to ECU)	-- (No start)	Unable	Unable
21	Coolant temperature sensor	• Fixes the coolant temperature to 60 °C.	Able	Able
22	Intake temperature sensor	• Fixes the intake temperature to 20 °C.	Able	Able
23	Atmospheric pressure sensor	• Fixes the atmospheric pressure to 760 mmHg.	Able	Able
24 31 32	O ₂ sensor (inactive) (compensation stuck to upper limit) (compensation stuck to lower limit)	--	Able	Able
33 34	Faulty ignition	• Fuel is cut off only to the cylinder in which a malfunction is detected.	Able (depending on the number of faulty cylinders)	Able (depending on the number of faulty cylinders)
30 41	Lean angle cut-off switch (latch up detected) (open or short circuit)	• Turns OFF the fuel injection system relay of the fuel system.	Unable	Unable
42	Speed sensor, neutral switch	• Fixes the gear to the top gear.	Able	Able
43	Fuel system voltage (monitor voltage)	• Fixes the battery voltage to 12 V.	Able	Able
44	Error in writing the amount of CO adjustment on EEPROM	--	Able	Able
50	ECU internal malfunction (memory check error)	--	Unable	Unable

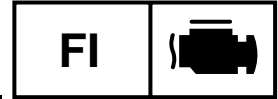

TROUBLESHOOTING

Diagnosis mode troubleshooting 1 (self-diagnostic malfunction detected)

By entering a diagnostic code in the ECU through the use of the “SELECT” and “RESET” buttons on the multi-function meter, the sensor output values can be displayed and the actuators can be operated in accordance with the code that has been entered.

The technician determines whether or not the operation is normal by verifying the values displayed on the multi-function meter or the operating conditions of the actuators. These modes can be used to detect and check the problems that are otherwise difficult to detect in the diagnosis mode.

Basic operation procedure

Operation preparation

- Verify the self-diagnostic fault code number that is displayed on the meter.
- Based on the self-diagnostic fault code number, select the applicable sensor or actuator from the diagnostic code table.
- If a diagnostic code is available, proceed with the operation procedure given below in order to verify the operating conditions of the applicable sensor or actuator.

Operation procedure (make sure to turn “OFF” the main switch upon completing the operation preparation)

<p>Setting the ECU in the diagnosis mode</p> <p>1. While keeping the “SELECT” and “RESET” buttons pressed simultaneously, turn “ON” the main switch (keep them pressed for 8 seconds or more).</p> <p>* All indications on the meter disappear except the clock and trip indications.</p> <p>* Letters “dIAG” appear on the clock LCD.</p>	<p>The diagram shows the multi-function meter with 'dIAG' displayed on the clock LCD. Below the meter are the 'SELECT' and 'RESET' buttons. To the right is the 'Main switch' with a paperclip inserted, and an arrow indicating it is being turned from 'OFF' to 'ON'.</p>
--	---



<p>Selecting the diagnosis mode</p> <p>Using the “SELECT” button, select either the CO adjustment mode (which appears as “CO”) or the diagnosis mode (which appears as “dIAG”).</p> <p>After “dIAG” appears as a result of pressing the “SELECT” button, simultaneously press the “SELECT” and “RESET” buttons for 2 seconds or more to execute the selection.</p>	<p>The diagram shows the multi-function meter with 'dIAG' displayed on the clock LCD. Below the meter are the 'SELECT' and 'RESET' buttons. To the right is the 'Main switch' with a paperclip inserted, and an arrow indicating it is being turned from 'OFF' to 'ON'.</p>
--	---





Verifying the operation of various sensors and actuators

1. Disconnect the wiring harness coupler from the fuel pump.
2. Turn the engine stop switch "OFF".
 - Turn the engine stop switch "ON" if diagnostic code numbers 03 and 09 are shown.
3. Select the diagnostic code number that applies to the item that was verified with the self-diagnostic fault code number, and enter it on the meter by operating the "SELECT" or "RESET" button.
 - * "RESET" button
 - Decrement (press 1 second or longer → auto)
 - "SELECT" button
 - Increment (press 1 second or longer → auto)
 - * Diagnostic code number appears on clock LCD (01 ~ 70)
4. Verifying the operation of the displayed diagnostic code
 - Verifying various sensors
 - The data representing the operating conditions of the sensors appears on the trip LCD (throttle position sensor angle, coolant temperature, atmospheric pressure, etc.)
 - Verifying the operation of actuators
 - Start the operation by turning the stop switch "ON" (injectors, relay, ignition coil, AIS, etc.)
 - * If the stop switch is "ON", turn it "OFF"; then, turn it back "ON".
5. Check the results by referring to the sensor operation data verification table or the actuator operation verification table.

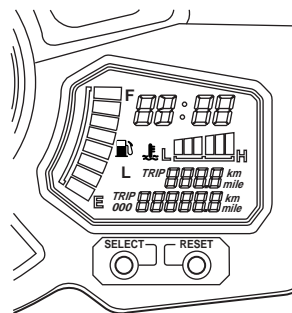
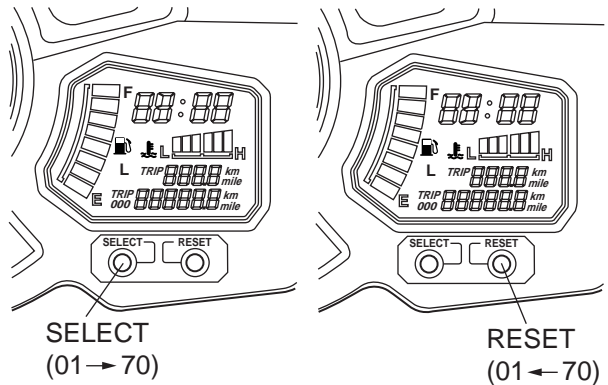

Perform individual repairs on the areas where malfunctions have been identified.

FUEL INJECTION SYSTEM

FI



Erase the codes appearing on the meter upon the completion of the operation (reinstating the ECU).

- * Verify the reinstatement procedures detailed in the troubleshooting details in order to carry out the reinstatement operation that is applicable to the malfunctioning item.
Refer to the troubleshooting details.



Erase the fault code from memory.

- * Perform the operation for diagnostic code 62.



Self-diagnostic fault codes, symptoms, and probable causes

Diagnostic code indication

Code No.	Symptom	Probable cause of malfunction	Diagnostic code
11	No normal signals are received from the cylinder identification sensor.	<ul style="list-style-type: none"> • Open or short circuit in wiring sub lead. • Open or short circuit in wiring harness. • Defective cylinder identification sensor. • Malfunction in ECU. • Improperly installed sensor. 	—
12	No normal signals are received from the crankshaft position sensor.	<ul style="list-style-type: none"> • Open or short circuit in wiring harness. • Defective crankshaft position sensor. • Malfunction in pickup rotor. • Malfunction in ECU. • Improperly installed sensor. 	—
13	Intake air pressure sensor - open or short circuit detected.	<ul style="list-style-type: none"> • Open or short circuit in wiring sub lead. • Open or short circuit in wiring harness. • Defective intake air pressure sensor. • Malfunction in ECU. 	03
14	Faulty intake air pressure sensor pipe system; a hose is detached, causing constant application of the atmospheric pressure to the sensor; or, the hose is clogged.	<ul style="list-style-type: none"> • Intake air pressure sensor hose is detached, clogged, kinked, or pinched. • Malfunction of the intake air pressure sensor in the intermediate electrical potential. • Malfunction of the atmospheric pressure sensor in the intermediate electrical potential. • Malfunction in ECU. 	03 02
	Or, intake air pressure sensor - open or short circuit detected.	<ul style="list-style-type: none"> • Open or short circuit in wiring sub lead. • Open or short circuit in wiring harness. • Defective intake air pressure sensor. • Malfunction in ECU. 	03
	Or, a stuck throttle position sensor is detected.	<ul style="list-style-type: none"> • Open or short circuit in wiring sub lead. • Open or short circuit in wiring harness. • Defective sensor (stuck throttle position sensor). 	01
15	Throttle position sensor - open or short circuit detected.	<ul style="list-style-type: none"> • Open or short circuit in wiring sub lead. • Open or short circuit in wiring harness. • Defective throttle position sensor. • Malfunction in ECU. • Improperly installed throttle position sensor. 	01
16	A stuck throttle position sensor is detected. Or, Faulty intake air pressure sensor pipe system; a hose is detached, causing constant application of the atmospheric pressure to the sensor; or, the hose is clogged.	<ul style="list-style-type: none"> • Open or short circuit in wiring sub lead. • Open or short circuit in wiring harness. • Defective sensor (stuck throttle position sensor). • Intake air pressure sensor hose is detached, clogged, kinked, or pinched. • Malfunction of the intake air pressure sensor in the intermediate electrical potential. • Malfunction of the atmospheric pressure sensor in the intermediate electrical potential. • Malfunction in ECU. 	01 03 02
19	Open circuit in the input line from the sidestand switch to the ECU is detected when the start switch is pressed.	<ul style="list-style-type: none"> • Open or short circuit in wiring harness. • Malfunction in ECU. 	20
21	Coolant temperature sensor - open or short circuit detected.	<ul style="list-style-type: none"> • Open or short circuit in wiring harness. • Defective coolant temperature sensor. • Malfunction in ECU. • Improperly installed sensor. 	06
22	Intake temperature sensor - open or short circuit detected.	<ul style="list-style-type: none"> • Open or short circuit in wiring harness. • Defective intake temperature sensor. • Malfunction in ECU. • Improperly installed sensor. 	05

FUEL INJECTION SYSTEM

FI

Code No.	Symptom	Probable cause of malfunction	Diagnostic code
23	Atmospheric pressure sensor - open or short circuit detected.	<ul style="list-style-type: none"> • Open or short circuit in wiring harness. • Defective atmospheric pressure sensor. • Improperly installed sensor. • Malfunction in ECU. 	02
24	No normal signals are received from the O ₂ sensor.	<ul style="list-style-type: none"> • Open or short circuit in wiring harness. • Defective O₂ sensor. • Malfunction in ECU. • Improperly installed sensor. 	—
30	The motorcycle has overturned.	<ul style="list-style-type: none"> • Overturned. • Malfunction in ECU. 	08
31	The amount of air-fuel ratio feedback compensation is maintained continuously in the vicinity of the upper limit (lean air-fuel ratio).	<ul style="list-style-type: none"> • Open or short circuit in wiring harness. • Fuel pressure too low. • Clogged injectors. • Defective O₂ sensor (unable to output a rich signal). • Malfunction in ECU. • Malfunction in other areas of the fuel system. 	—
32	The amount of air-fuel ratio feedback compensation is maintained continuously in the vicinity of the lower limit (rich air-fuel ratio).	<ul style="list-style-type: none"> • Open or short circuit in wiring harness. • Fuel pressure too high. • Faulty injectors (excessive injection volume). • Defective O₂ sensor (unable to output a lean signal). • Malfunction in ECU. • Malfunction in other areas of the fuel system. 	—
33	Open circuit is detected in the primary wire of the ignition coil (#1, 4).	<ul style="list-style-type: none"> • Open or short circuit in wiring harness. • Malfunction in ignition coil. • Malfunction in ECU. • Malfunction in a component of ignition cutoff circuit system. 	30
34	Open circuit is detected in the primary wire of the ignition coil (#2, 3).	<ul style="list-style-type: none"> • Open or short circuit in wiring harness. • Malfunction in ignition coil. • Malfunction in ECU. • Malfunction in a component of ignition cutoff circuit system. 	31
41	Lean angle cut-off switch - open or short circuit detected.	<ul style="list-style-type: none"> • Open or short circuit in wiring harness. • Defective lean angle cut-off switch. • Malfunction in ECU. 	08
42	No normal signals are received from the speed sensor; or, an open or short circuit is detected in the neutral switch.	<ul style="list-style-type: none"> • Open or short circuit in wiring harness. • Defective speed sensor. • Malfunction in vehicle speed sensor detected unit. • Defective neutral switch. • Malfunction in the engine side of the neutral switch. • Malfunction in ECU. 	07 21
43	The ECU is unable to monitor the battery voltage (an open circuit in the monitor line to the ECU).	<ul style="list-style-type: none"> • Open circuit in wiring harness. • Malfunction in ECU. 	—
44	An error is detected while reading or writing on EEPROM.	<ul style="list-style-type: none"> • Malfunction in ECU. (The CO adjustment value is not properly written on or read from the internal memory). 	60
50	Faulty ECU memory. When this malfunction is detected, the code number might not appear on the meter.	<ul style="list-style-type: none"> • Malfunction in ECU. (The program and data are not properly written on or read from the internal memory.) 	—

FUEL INJECTION SYSTEM

FI



Sensor operation data display verification table

NOTE:

- Check the intake temperature and coolant temperature as close as possible to the area in which the respective sensor is mounted.
- If it is not possible to check it with an atmospheric pressure gauge, judge it by using 760 mmHg as the standard.
- If it is not possible to check the intake temperature, use the ambient temperature as reference (use the compared values for reference).

Diag code	Item	Description of action	Data displayed on meter (reference value)
01	Throttle angle	Displays the throttle angle. • Check with throttle fully closed. • Check with throttle fully open.	0 ~ 125 degrees • Fully closed position (15 ~ 17) • Fully open position (97 ~ 100)
02	Atmospheric pressure	Displays the atmospheric pressure. * Use an atmospheric pressure gauge to check the atmospheric pressure.	Compare it to the value displayed on the meter.
03	Pressure difference (atmospheric pressure - intake air pressure)	Displays the pressure difference (atmospheric pressure - intake air pressure). Engine stop switch is on. * Generate the pressure difference by cranking the engine with the starter, without actually starting the engine.	10 ~ 200 mmHg
05	Intake temperature	Displays the intake air temperature. * Check the temperature in the air cleaner case.	Compare it to the value displayed on the meter.
06	Coolant temperature	Displays the coolant temperature. * Check the temperature of the coolant.	Compare it to the value displayed on the meter.
07	Vehicle speed pulse	Displays the accumulation of the vehicle pulses that are generated when the tire is spun.	(0 ~ 999; resets to 0 after 999) OK if the numbers appear on the meter.
08	Lean angle cut-off switch	Displays the lean angle cut-off switch values.	Upright: 0.4 ~ 1.4 V Overtuned: 3.8 ~ 4.2 V
09	Fuel system voltage (battery voltage)	Displays the fuel system voltage (battery voltage). Engine stop switch is on.	0 ~ 18.7 V Normally, approximately 12.0 V
20	Sidestand switch	Displays that the switch is ON or OFF. (When the gear is in a position other than neutral.)	Stand retracted: ON Stand extended: OFF
21	Neutral switch	Displays that the switch is ON or OFF.	Neutral: ON In gear: OFF
60	E2PROM fault code display	• Transmits the abnormal portion of the data in the E2PROM that has been detected as a self-diagnostic fault code 44. • If multiple malfunctions have been detected, different codes are displayed at 2-second intervals, and this process is repeated.	(01 ~ 04) Displays the cylinder number. (00) Displays when there is no malfunction.
61	Malfunction history code display	• Displays the codes of the history of the self-diagnosis malfunctions (i.e., a code of a malfunction that occurred once and which has been corrected). • If multiple malfunctions have been detected, different codes are displayed at 2-second intervals, and this process is repeated.	11 ~ 50 (00) Displays when there is no malfunction.
62	Malfunction history code erasure	• Displays the total number of codes that are being detected through self diagnosis and the fault codes in the past history. • Erases only the history codes when the engine stop switch is turned from OFF to ON. If the engine stop switch is ON, turn it OFF once, and then turn it back ON.	00 ~ 21 (00) Displays when there is no malfunction.
70	Control number	• Displays the program control number.	00 ~ 255

FUEL INJECTION SYSTEM

FI



Actuator operation verification table

Diag code	Item	Description of action	Data displayed on meter (reference value)
30	Ignition coil #1, 4	After 1 second has elapsed from the time the engine stop switch has been turned from OFF to ON, it actuates ignition coils #1, and 4 for five times every second and illuminates the engine trouble warning light. * Connect an ignition checker. * If the engine stop switch is ON, turn it OFF once, and then turn it back ON.	Check that spark is generated, 5 times with the engine stop switch ON.
31	Ignition coils #2, 3	Take the same actions as No. 30 above on ignition coils #2, and 3. Same as above. * If the engine stop switch is ON, turn it OFF once, and then turn it back ON.	Same as above
36	Injector #1	After 1 second has elapsed from the time the engine stop switch has been turned from OFF to ON, it actuates the injector five times every second and illuminates the engine trouble warning light. * If the engine stop switch is ON, turn it OFF once, and then turn it back ON.	Check the operating sound of the injector five times with engine stop switch ON.
37	Injector #2	Take the same actions as No. 36 above on injector #2. * If the engine stop switch is ON, turn it OFF once, and then turn it back ON.	Same as above
38	Injector #3	Take the same actions as No. 36 above on injector #3. * If the engine stop switch is ON, turn it OFF once, and then turn it back ON.	Same as above
39	Injector #4	Take the same actions as No. 36 on injector #4. * If the engine stop switch is ON, turn it OFF once, and then turn it back ON.	Same as above
48	AI system solenoid	After 1 second has elapsed from the time the engine stop switch has been turned from OFF to ON, it actuates the AI system solenoid five times every second and illuminates the engine trouble warning light. * If the engine stop switch is ON, turn it OFF once, and then turn it back ON.	Check the operating sound of the AI system solenoid. Same as above
50	Fuel injection system relay	After 1 second has elapsed from the time the engine stop switch has been turned from OFF to ON, it actuates the fuel injection system relay five times every second and illuminates the engine trouble warning light (the light is OFF when the relay is ON, and the light is ON when the relay is OFF). * If the engine stop switch is ON, turn it OFF once, and then turn it back ON.	Check the fuel injection system relay operating sound. Same as above
51	Radiator fan motor relay	After 1 second has elapsed from the time the engine stop switch has been turned from OFF to ON, it actuates the radiator fan motor relay five times every 5 seconds and illuminates the engine trouble warning light. (ON 2 seconds, OFF 3 seconds) * If the engine stop switch is ON, turn it OFF once, and then turn it back ON.	Check the radiator fan motor relay operating sound. Same as above
52	Headlight relay 1	Take the same actions as in No. 51 above, on the headlight relay 1. (ON 2 seconds, OFF 3 seconds) * If the engine stop switch is ON, turn it OFF once, and then turn it back ON.	Check the relay operating sound. Same as above

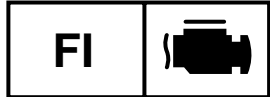

Troubleshooting Basic procedure 1

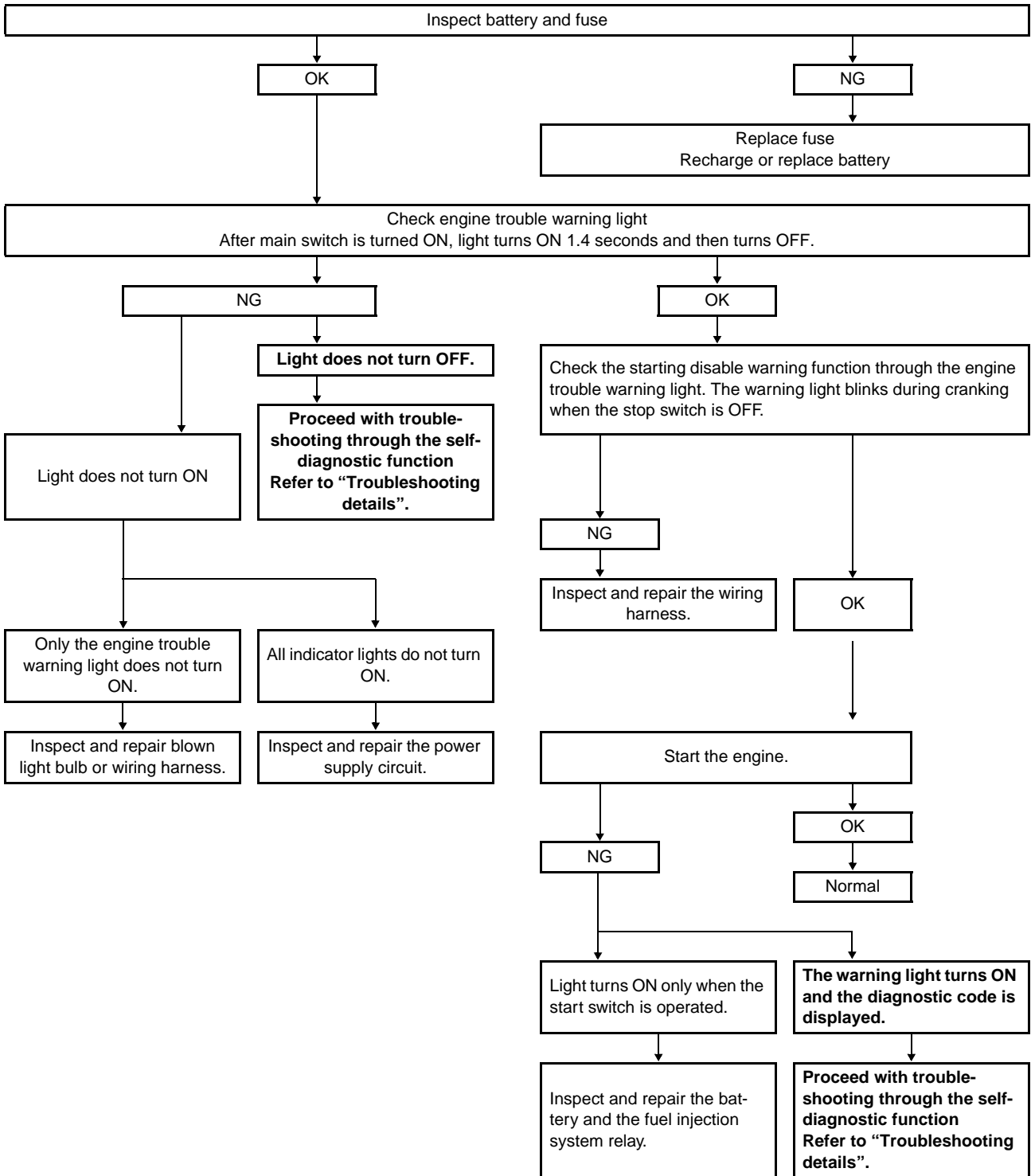

FUEL INJECTION SYSTEM

FI



Troubleshooting details

Troubleshooting the self-diagnostic fault code

Code No.	11	Symptom	No normal signals are received from the cylinder identification sensor.	
Used diagnostic code No.				
Inspection operation item		Operation item and countermeasure		Reinstatement method
Installed state of sensor		Check the installed area for looseness or pinching.		Reinstated by starting the engine and operating it at idle.
Defective cylinder identification sensor.		Replace if defective. Refer to "FUEL INJECTION SYSTEM" in chapter 8.		
Open or short circuit in wiring harness or sub lead.		Repair or replace if there is an open or short circuit. Between main wiring harness and sub lead Blue - Blue White/Black - White Black/Blue - Black/Blue		
Connected state of connector Inspect the coupler for any pins that may have pulled out. Check the locking condition of the coupler.		If there is a malfunction, repair it and connect it securely. Cylinder identification sensor coupler Main wiring harness ECU coupler Sub-wire harness coupler		

Code No.	12	Symptom	No normal signals are received from the crankshaft position sensor.	
Used diagnostic code No.				
Inspection operation item and probable cause		Operation item and countermeasure		Reinstatement method
Installed state of sensor		Check the installed area for looseness or pinching.		Reinstated by cranking the engine.
Defective crankshaft position sensor.		Replace if defective. Refer to "FUEL INJECTION SYSTEM" in chapter 8.		
Open or short circuit in wiring harness or sub lead.		Repair or replace if there is an open or short circuit between the main wiring harnesses. Gray - Gray Black/Blue - Black/Blue		
Connected state of connector Inspect the coupler for any pins that may have pulled out. Check the locking condition of the coupler.		If there is a malfunction, repair it and connect it securely. Crankshaft position sensor coupler Main wiring harness ECU coupler		

FUEL INJECTION SYSTEM

FI



Code No.	13	Symptom	Intake air pressure sensor - open or short circuit detected.	
Used diagnostic code No. 03 (intake air pressure sensor)				
Inspection operation item and probable cause		Operation item and countermeasure		Reinstatement method
Defective intake air pressure sensor		Replace if defective. Refer to "FUEL INJECTION SYSTEM" in chapter 8.		Reinstated by turning the main switch ON.
Open or short circuit in wiring harness or sub lead.		Repair or replace if there is an open or short circuit. Main wiring harness Black/Blue - Black/Blue Pink/White - Pink/White Blue - Blue Sub lead Black/Blue - Black/Blue Pink/White - Pink/White Blue - Blue		
Connected state of connector Inspect the coupler for any pins that may have pulled out. Check the locking condition of the coupler.		If there is a malfunction, repair it and connect it securely. Intake air pressure sensor coupler Main wiring harness ECU coupler Sub-wire harness coupler		

FUEL INJECTION SYSTEM

FI



Code No.	14	Symptom	1 Intake air pressure sensor - pipe system malfunction (clogged or detached hose). 2 Intake air pressure sensor - open or short circuit detected. 3 Stuck throttle position sensor detected.	
Used diagnostic code		No. 03 (intake air pressure sensor) No. 02 (atmospheric pressure sensor) No. 01 (throttle position sensor)		
Inspection operation item and probable cause		Operation item and countermeasure		Reinstatement method
1 Intake air pressure sensor hose detached, clogged, kinked, or pinched. Intake air pressure sensor malfunction at intermediate electrical potential. Atmospheric pressure sensor malfunction at intermediate electrical potential.		Repair or replace the sensor hose. Inspect and repair the connection. Replace it if there is a malfunction.		Reinstated by starting the engine and operating it at idle.
2 Open or short circuit in wiring harness or sub lead.		Repair or replace if there is an open or short circuit. Main wiring harness Black/Blue - Black/Blue Pink/White - Pink/White Blue - Blue Sub lead Black/Blue - Black/Blue Pink/White - Pink/White Blue - Blue		
Defective intake air pressure sensor.		Replace if defective. Refer to "FUEL INJECTION SYSTEM" in chapter 8.		
3 Open or short circuit in wiring harness or sub lead.		Repair or replace if there is an open or short circuit. Main wiring harness Black/Blue - Black/Blue Yellow - Yellow Blue - Blue Sub lead Black/Blue - Black/Blue Yellow - Yellow Blue - Blue		Reinstated by starting the engine, operating it at idle, and then by racing it.
Defective throttle position sensor.		Replace if defective. Refer to "FUEL INJECTION SYSTEM" in chapter 8.		
Throttle position sensor lead wire open circuit output voltage check (B/L - Y) Black/Blue - Yellow		Open circuit item: Output voltage Ground wire open circuit: 5 V Output wire open circuit: 0 V Power supply wire open circuit: 0 V Check for open circuit and replace the throttle position sensor.		
Common to 1, 2, and 3: Connected state of connector Inspect the coupler for any pins that may have pulled out. Check the locking condition of the coupler.		If there is a malfunction, repair it and connect it securely. Intake air pressure sensor coupler Main wiring harness ECU coupler		Reinstated by starting the engine and operating it at idle.

FUEL INJECTION SYSTEM

FI



Code No.	15	Symptom	Throttle position sensor - open or short circuit detected.	
Used diagnostic code No. 01 (throttle position sensor)				
Inspection operation item and probable cause		Operation item and countermeasure		Reinstatement method
Defective throttle position sensor.		Replace if defective. Refer to "FUEL INJECTION SYSTEM" in chapter 8.		Reinstated by turning the main switch ON.
Throttle position sensor lead wire open circuit output voltage check (B/L - Y) Black/Blue - Yellow		Open circuit item: Output voltage Ground wire open circuit: 5 V Output wire open circuit: 0 V Power supply wire open circuit: 0 V Check for open circuit and replace the throttle position sensor.		
Open or short circuit in wiring harness or sub lead.		Repair or replace if there is an open or short circuit. Main wiring harness Black/Blue - Black/Blue Yellow - Yellow Blue - Blue Sub lead Black/Blue - Black/Blue Yellow - Yellow Blue - Blue		
Installed state of throttle position sensor.		Check the installed area for looseness or pinching. Check that it is installed in the specified position. Refer to "FUEL INJECTION SYSTEM" in chapter 8.		
Connected state of connector Inspect the coupler for any pins that may have pulled out. Check the locking condition of the coupler.		If there is a malfunction, repair it and connect it securely. Throttle position sensor coupler Main wiring harness ECU coupler		

FUEL INJECTION SYSTEM

FI



Code No.	16	Symptom	1 Stuck throttle position sensor detected. 2 Intake air pressure sensor - pipe system malfunction (clogged or detached hose).	
Used diagnostic code		No. 03 (intake air pressure sensor) No. 02 (atmospheric pressure sensor) No. 01 (throttle position sensor)		
Inspection operation item and probable cause		Operation item and countermeasure		Reinstatement method
1 Defective throttle position sensor.		Replace if defective. Refer to "FUEL INJECTION SYSTEM" in chapter 8.		Reinstated by starting the engine, operating it at idle, and then racing it.
Throttle position sensor lead wire open circuit output voltage check (B/L - Y) Black/Blue - Yellow		Open circuit item: Output voltage Ground wire open circuit: 5 V Output wire open circuit: 0 V Power supply wire open circuit: 0 V Check for open circuit and replace the throttle position sensor.		
2 Open or short circuit in wiring harness or sub lead.		Repair or replace if there is an open or short circuit. Main wiring harness Black/Blue - Black/Blue Yellow - Yellow Blue - Blue Sub lead Black/Blue - Black/Blue Yellow - Yellow Blue - Blue		
1 Installed state of throttle position sensor.		Check the installed area for looseness or pinching. Check that it is installed in the specified position. Refer to "FUEL INJECTION SYSTEM" in chapter 8.		
2 Intake air pressure sensor hose detached, clogged, kinked, or pinched. Intake air pressure sensor malfunction at intermediate electrical potential. Atmospheric pressure sensor malfunction at intermediate electrical potential.		Repair or replace the sensor hose. Inspect and repair the connection. Replace it if there is a malfunction.		
Common to 1 and 2: Connected state of connector Inspect the coupler for any pins that may have pulled out. Check the locking condition of the coupler.		If there is a malfunction, repair it and connect it securely. Throttle position sensor coupler Main wiring harness ECU coupler Sub-wire harness coupler		

FUEL INJECTION SYSTEM

FI

Code No.	19	Symptom	Open circuit is detected in the input line from the sidestand switch to the ECU.	
Used diagnostic code No. 20 (sidestand switch)				
Inspection operation item and probable cause		Operation item and countermeasure		Reinstatement method
Defective sidestand switch		Replace if defective. Refer to "CHECKING THE SWITCHES" in chapter 8.		If the transmission is in gear, it is reinstated by retracting the sidestand. If the transmission is in neutral, it is reinstated by reconnecting the wiring.
Open or short circuit in wiring harness or sub lead.		Repair or replace if there is an open or short circuit. (Between ECU and sidestand)		
Connected state of connector Inspect the coupler for any pins that may have pulled out. Check the locking condition of the coupler.		If there is a malfunction, repair it and connect it securely. Main wiring harness ECU coupler (No. 43 pin, black) (Alarm coupler) ECU coupler illustration (Indicate No. 43 pin)		

Code No.	21	Symptom	Open or short circuit is detected from the coolant temperature sensor.	
Used diagnostic code No. 06 (coolant temperature sensor)				
Inspection operation item and probable cause		Operation item and countermeasure		Reinstatement method
Installed state of sensor		Check the installed area for looseness or pinching.		Reinstated by turning the main switch ON.
Defective coolant temperature sensor.		Replace if defective. Refer to "FUEL INJECTION SYSTEM" in chapter 8.		
Open or short circuit in wiring harness or sub lead.		Repair or replace if there is an open or short circuit. Main wiring harness Black/Blue - Black/Blue Green/White - Green/White		
Connected state of connector Inspect the coupler for any pins that may have pulled out. Check the locking condition of the coupler.		If there is a malfunction, repair it and connect it securely. Coolant temperature sensor coupler Main wiring harness ECU coupler		

Code No.	22	Symptom	Open or short circuit detected from the intake temperature sensor.	
Used diagnostic code No. 05 (intake temperature sensor)				
Inspection operation item and probable cause		Operation item and countermeasure		Reinstatement method
Installed state of sensor		Check the installed area for looseness or pinching.		Reinstated by turning the main switch ON.
Defective intake temperature sensor.		Replace if defective. Refer to "FUEL INJECTION SYSTEM" in chapter 8.		
Open or short circuit in wiring harness or sub lead.		Repair or replace if there is an open or short circuit. Main wiring harness Black/Blue - Black/Blue Brown/White - Brown/White		
Connected state of connector Inspect the coupler for any pins that may have pulled out. Check the locking condition of the coupler.		If there is a malfunction, repair it and connect it securely. Intake temperature sensor coupler Main wiring harness ECU coupler		

FUEL INJECTION SYSTEM

FI



Code No.	23	Symptom	Open or short circuit detected from the atmospheric pressure sensor.	
Used diagnostic code No. 02 (atmospheric pressure sensor)				
Inspection operation item and probable cause		Operation item and countermeasure		Reinstatement method
Defective atmospheric pressure sensor.		Replace if defective. Refer to "FUEL INJECTION SYSTEM" in chapter 8.		Reinstated by turning the main switch ON.
Open or short circuit in wiring harness or sub lead.		Repair or replace if there is an open or short circuit. Main wiring harness Blue - Blue Black/Blue - Black/Blue Pink - Pink		
Installed state of atmospheric pressure sensor		Check the installed area for looseness or pinching.		
Connected state of connector Inspect the coupler for any pins that may have pulled out. Check the locking condition of the coupler.		If there is a malfunction, repair it and connect it securely. Atmospheric pressure sensor coupler Main wiring harness ECU coupler		

Code No.	24	Symptom	No normal signal is received from the O ₂ sensor.	
Used diagnostic code No.				
Inspection operation item and probable cause		Operation item and countermeasure		Reinstatement method
Defective O ₂ sensor.		Replace if defective.		Reinstated by starting the engine, operating it at idle, and then racing it after it has warmed up.
Open or short circuit in wiring harness or sub lead.		Repair or replace if there is an open or short circuit. Main wiring harness Black/Blue - White Gray/Green - Blue		
Installed state of O ₂ sensor		Check the installed area for looseness or pinching.		
Connected state of connector Inspect the coupler for any pins that may have pulled out. Check the locking condition of the coupler.		If there is a malfunction, repair it and connect it securely. O ₂ sensor coupler Main wiring ECU harness coupler Sub-wire harness coupler		
Check fuel pressure		Inspect fault codes 31/32. Refer to "CHECKING THE FUEL PUMP AND PRESSURE REGULATOR OPERATION".		

FUEL INJECTION SYSTEM

FI



Code No.	30	Symptom	The motorcycle has overturned.	
Used diagnostic code No. 08 (lean angle cut-off switch)				
Inspection operation item and probable cause		Operation item and countermeasure		Reinstatement method
Defective lean angle cut-off switch		Replace if defective.		Reinstated by turning the main switch ON (however, the engine cannot be restarted unless the main switch is first turned OFF).
The motorcycle has overturned.		Raise the motorcycle upright.		
Installed state of the lean angle cut-off switch		Check the installed area for looseness or pinching.		
Connected state of connector Inspect the coupler for any pins that may have pulled out. Check the locking condition of the coupler.		If there is a malfunction, repair it and connect it securely. Lean angle cut-off switch coupler Main wiring harness ECU coupler		

Code No.	31	Symptom	The amount of air-fuel ratio feedback compensation is maintained continuously in the vicinity of the upper limit.	
Used diagnostic code No. 01 (throttle position sensor)				
Inspection operation item and probable cause		Operation item and countermeasure		Reinstatement method
Defective O ₂ sensor (unable to output a rich signal).		Replace if defective.		Reinstated by starting the engine, operating it at idle, and then racing it after it has warmed up.
Clogged injector.		Replace if defective. Refer to "CHECKING THE INJECTOR".		
Open circuit or ground short in wiring harness or sub lead.		Repair or replace if there is an open or short circuit. Main wiring harness Black/Blue - White Gray/Green - Blue		
The fuel pressure is too low. Compare the fuel pressure at idle and with throttle open. About the same → Normal Too low → Inspect the fuel pump. Inspect the delivery hose for pinching or kinking. Inspect the pressure regulator. Inspect the throttle position sensor. Other: Malfunction in the fuel system (disconnection, etc.). Improper sealing of the intake system.		Replace if defective. Refer to "CHECKING THE FUEL PUMP AND PRESSURE REGULATOR OPERATION". Repair or replace if there is a malfunction. Replace if defective. Refer to "CHECKING THE FUEL PUMP AND PRESSURE REGULATOR OPERATION". Execute diagnostic code 01.		
Connected state of connector Inspect the coupler for any pins that may have pulled out. Check the locking condition of the coupler.		If there is a malfunction, repair it and connect it securely. O ₂ sensor coupler Engine wiring harness coupler Main wiring harness ECU coupler Sub-wire harness coupler		

FUEL INJECTION SYSTEM

FI



Code No.	32	Symptom	The amount of air-fuel ratio feedback compensation is maintained continuously in the vicinity of the lower limit (air-fuel ratio is rich).	
Used diagnostic code No. 01 (throttle position sensor)				
Inspection operation item and probable cause		Operation item and countermeasure		Reinstatement method
Defective O ₂ sensor (unable to output a lean signal).		Replace if defective.		Reinstated by starting the engine, operating it at idle, and then racing it after it has warmed up.
Excessive volume of fuel injected by injector.				
Open circuit on the 5 V side or short circuit in wiring harness or sub lead.		Repair or replace if there is an open or short circuit. Main wiring harness Black/Blue - White Gray/Green - Blue		
<p>The fuel pressure is too high. Compare the fuel pressure at idle and with throttle open. About the same → Normal Too high →</p> <p>Inspect the pressure regulator. Inspect the pressure regulator hose for pinching or kinking. Inspect the fuel return hose for pinching or kinking. Inspect the throttle position sensor.</p> <p>Other: Malfunction in the fuel system (clogging, etc.).</p>		<p>Replace if defective. Refer to "CHECKING THE FUEL PUMP AND PRESSURE REGULATOR OPERATION". Repair or replace if there is a malfunction.</p> <p>Repair or replace if there is a malfunction.</p> <p>Execute diagnostic code 01.</p> <p>Repair or replace if there is a malfunction.</p>		
<p>Connected state of connector Inspect the coupler for any pins that may have pulled out. Check the locking condition of the coupler.</p>		<p>If there is a malfunction, repair it and connect it securely. O₂ sensor coupler Sub wiring harness coupler Main wiring harness ECU coupler Sub-wire harness coupler</p>		

FUEL INJECTION SYSTEM

FI



Code No.	33	Symptom	Malfunction detected in the primary wire of the ignition coil (#1, 4).	
Used diagnostic code No. 30 (ignition coil #1, 4)				
Inspection operation item and probable cause		Operation item and countermeasure		Reinstatement method
Defective ignition coil (test the primary and secondary coils for continuity).		Replace if defective. Refer to "IGNITION SYSTEM" in chapter 8.		Reinstated by starting the engine and operating it at idle.
Open or short circuit in lead wire.		Repair or replace if there is an open or short circuit. Main wiring harness Orange - Orange Red/Black - Red/Black		
Connected state of connector Inspect the coupler for any pins that may have pulled out. Check the locking condition of the coupler.		If there is a malfunction, repair it and connect it securely. Ignition coil primary side coupler - Orange Main wiring harness ECU coupler		

Code No.	34	Symptom	Malfunction detected in the primary wire of the ignition coil (#2, 3).	
Used diagnostic code No. 31 (ignition coil #2, 3)				
Inspection operation item and probable cause		Operation item and countermeasure		Reinstatement method
Defective ignition coil (test the primary and secondary coils for continuity).		Replace if defective. Refer to "IGNITION SYSTEM" in chapter 8.		Reinstated by starting the engine and operating it at idle.
Open or short circuit in lead wire.		Repair or replace if there is an open or short circuit. Main wiring harness Gray/Red - Gray/Red Red/Black - Red/Black		
Connected state of connector Inspect the coupler for any pins that may have pulled out. Check the locking condition of the coupler.		If there is a malfunction, repair it and connect it securely. Ignition coil primary side coupler - Gray/Red Main wiring harness ECU coupler		

Code No.	41	Symptom	Open or short circuit detected in the lean angle cut-off switch.	
Used diagnostic code No. 08 (lean angle cut-off switch)				
Inspection operation item and probable cause		Operation item and countermeasure		Reinstatement method
Defective lean angle cut-off switch		Replace if defective.		Reinstated by turning the main switch ON.
Open or short circuit in lead wire.		Repair or replace if there is an open or short circuit. Main wiring harness Black/Blue - Black/Blue Yellow/Green - Yellow/Green Red/White - Red/White		
Connected state of connector Inspect the coupler for any pins that may have pulled out. Check the locking condition of the coupler.		If there is a malfunction, repair it and connect it securely. Lean angle cut-off switch coupler Main wiring harness ECU coupler		

FUEL INJECTION SYSTEM

FI

Code No.	42	Symptom	1 No normal signals are received from the speed sensor. 2 Open or short circuit is detected in the neutral switch.	
Used diagnostic code		No. 07 (speed sensor) No. 21 (neutral switch)		
Inspection operation item and probable cause		Operation item and countermeasure		Reinstatement method
1 Defective speed sensor		Replace if defective. Refer to "FUEL INJECTION SYSTEM" in chapter 8.		Reinstated by starting the engine, and inputting the vehicle speed signals by operating the motorcycle at a low speed of 20 to 30 km/h.
1 Open or short circuit in lead wire.		Repair or replace if there is an open or short circuit. Main wiring harness Blue - Blue White/Yellow - White/Yellow Black/Blue - Black/Blue		
1 Gear for detecting vehicle speed has broken.		Replace if defective. Refer to "TRANSMISSION" in chapter 5.		
1 Connected state of connector Inspect the coupler for any pins that may have pulled out. Check the locking condition of the coupler.		If there is a malfunction, repair it and connect it securely. Speed sensor coupler Main wiring harness ECU coupler		
2 Defective neutral switch		Replace if defective. Refer to "CHECKING THE SWITCHES" in chapter 8.		
2 Faulty shift drum (neutral detection area)		Replace if defective. Refer to "TRANSMISSION" in chapter 5.		
2 Open or short circuit in lead wire		Repair or replace if there is an open or short circuit. Main wiring harness Sky blue/Sky blue		
2 Connected state of connector Inspect the coupler for any pins that may have pulled out. Check the locking condition of the coupler.		If there is a malfunction, repair it and connect it securely. Neutral switch coupler Main wiring harness ECU coupler		

Code No.	43	Symptom	The ECU is unable to monitor the battery voltage.	
Used diagnostic code		No. 50 (fuel injection system relay)		
Inspection operation item and probable cause		Operation item and countermeasure		Reinstatement method
Malfunction in ECU		Fuel injection system relay is on.		Reinstated by starting the engine and operating it at idle.
Open or short circuit in the wiring harness.		Repair or replace if there is an open or short circuit. Main wiring harness Red - Red Red/Black - Red/Black Red/Blue - Red/Blue Blue/Yellow - Blue/Yellow		
Malfunction or open circuit in fuel injection system relay		Replace if defective. Refer to "FUEL INJECTION SYSTEM" in chapter 8. If there is no malfunction with the fuel injection system relay, replace the ECU.		
Connected state of connector Inspect the coupler for any pins that may have pulled out. Check the locking condition of the coupler.		If there is a malfunction, repair it and connect it securely. Fuel injection system relay coupler ECU coupler		

FUEL INJECTION SYSTEM

FI

Code No.	44	Symptom	Error is detected while reading or writing on EEPROM (CO adjustment value).	
Used diagnostic No. 60 (EEPROM improper cylinder indication)				
Inspection operation item and probable cause		Operation item and countermeasure		Reinstatement method
Malfunction in ECU		Execute diagnostic code 60 * Check the faulty cylinder. (If there are multiple cylinders, the number of the faulty cylinders appear alternately at 2-second intervals.) * Readjust the CO of the displayed cylinder. Refer to "ADJUSTING THE EXHAUST GAS VOLUME" in chapter 3. Replace ECU if defective.		Reinstated by turning the main switch ON.

Code No.	50	Symptom	Faulty ECU memory. (When this malfunction is detected in the ECU, the fault code number might not appear on the meter.)	
Used diagnostic code No.				
Inspection operation item and probable cause		Operation item and countermeasure		Reinstatement method
Malfunction in ECU		Replace the ECU.		Reinstated by turning the main switch ON.

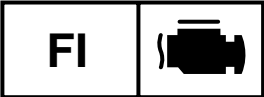

Diagnosis mode troubleshooting 2 (self-diagnostic malfunction not detected)

Even if the malfunctions of some of the sensors do not appear on the meter because they are not detected by the self-diagnostic function, they can be inspected in the diagnosis mode.

Basic procedure

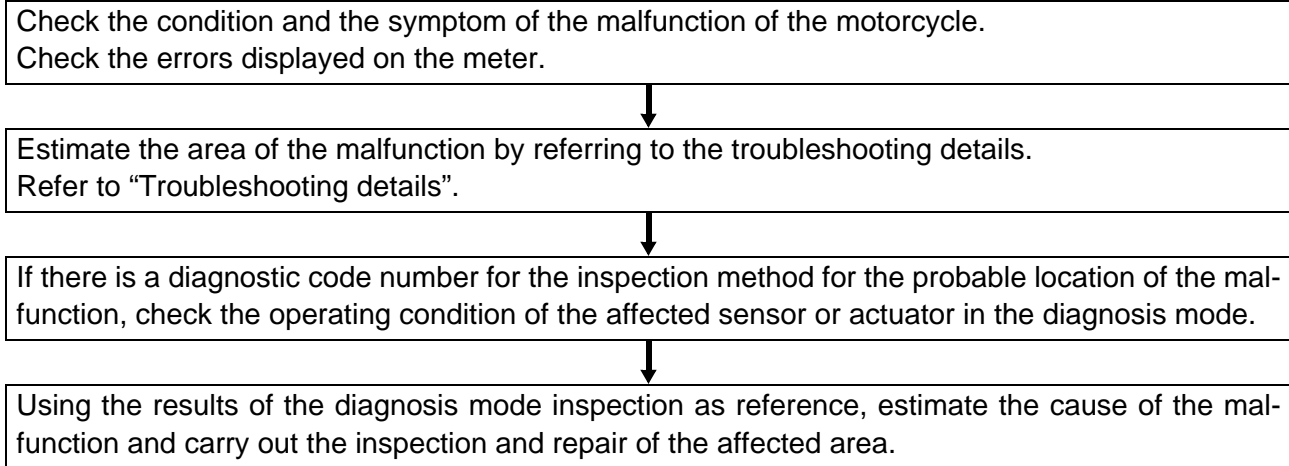

Troubleshooting details

Troubleshooting the sensors with no malfunctions detected, and special indications

Symptom	The engine trouble warning light does not illuminate when the start switch is pressed.	
Probable malfunction area	<ul style="list-style-type: none"> • Open or short circuit in start switch • Open or short circuit in wiring harness • Open circuit in warning light bulb 	
Inspection method 1 Inspection by diagnosis mode	Inspection method 2 Inspection of a malfunction that cannot be identified in the diagnosis mode, and in case the area of the malfunction has been narrowed down in the inspection method 1 indicated on the left.	
	<ul style="list-style-type: none"> • Open or short circuit in start switch Inspect the handlebar switch for continuity. Refer to "CHECKING THE SWITCHES" in chapter 8. Defective: replace • Open or short circuit in wiring harness Inspect the wiring harness and couplers for continuity. Defective: repair or replace • Open circuit in warning light bulb Inspect the bulb for continuity. Defective: replace 	

FUEL INJECTION SYSTEM

FI



Symptom	The headlight does not turn ON or OFF.	
Probable malfunction area	<ul style="list-style-type: none"> • Malfunction in the headlight relay 1 • Malfunction in the headlight • Open or short circuit in the headlight wiring harness • Malfunction in the handlebar switch • Open circuit in the headlight bulb 	
Inspection method 1 Inspection by diagnosis mode	Inspection method 2 Inspection of a malfunction that cannot be identified in the diagnosis mode, and in case the area of the malfunction has been narrowed down in the inspection method 1.	
<ul style="list-style-type: none"> • Execute diagnostic code No. 52 (check the operation of the headlight relay 1). (Check the operation of the headlight.) * Classify the malfunctions: <ul style="list-style-type: none"> Malfunction related to the relay Malfunction related to the wiring harness Malfunction in the headlight itself 	<ul style="list-style-type: none"> • Relay does not operate (as checked by sound or tester). Check the headlight relay 2. Refer to "LIGHTING SYSTEM" in chapter 8. Defective: replace Inspect the wiring harness and the couplers for continuity. Defective: repair or replace Replace • The relay operates but the headlight does not illuminate. Inspect the headlight bulb. Blown bulb: replace Check the headlight relay 2 contact point for continuity. Refer to "LIGHTING SYSTEM" in chapter 8. Defective: replace Check the handlebar switch. Defective: repair or replace Inspect the wiring harness and the couplers for continuity. Defective: repair or replace 	

FUEL INJECTION SYSTEM

FI



Symptom	Fan does not operate.	
Probable malfunction area	<ul style="list-style-type: none"> • Malfunction in radiator fan motor relay • Malfunction in fan • Open or short circuit in fan wiring harness 	
Inspection method 1 Inspection by diagnosis mode	Inspection method 2 Inspection of a malfunction that cannot be identified in the diagnosis mode, and in case the area of the malfunction has been narrowed down in the inspection method 1 given on the left.	
<ul style="list-style-type: none"> • Execute diagnostic code No. 51. (Check the operation of the radiator fan motor relay.) (Check the operation of the fan motor.) * Classify the malfunctions: <ul style="list-style-type: none"> Malfunction related to the relay Malfunction related to the wiring harness Malfunction in the fan itself 	<ul style="list-style-type: none"> • Relay does not operate. Check the radiator fan motor relay. Refer to "COOLING SYSTEM" in chapter 8. Defective: replace Inspect the wiring harness and couplers for continuity. Defective: repair or replace Replace • Relay operates but fan does not operate. Inspect the fan. Refer to "COOLING SYSTEM" in chapter 8. Defective: replace Check the continuity at the contact point of the radiator fan motor relay. Refer to "COOLING SYSTEM" in chapter 8. Defective: replace Inspect the wiring harness and couplers for continuity. Defective: repair or replace • Normal according to the diagnosis mode Inspect the coolant temperature sensor (by executing diagnostic code No. 06). Refer to "COOLING SYSTEM" in chapter 8. Defective: replace 	

Symptom	Clock LCD displays "Er-1". (No signals are received from the ECU.)	
Probable malfunction area	<ul style="list-style-type: none"> • Open or short circuit in communication line • Malfunction in meter • Malfunction in ECU 	
Inspection method 1 Inspection by diagnosis mode	Inspection method 2 Inspection of a malfunction that cannot be identified in the diagnosis mode, and in case the area of the malfunction has been narrowed down in the inspection method 1 given on the left.	
	<ul style="list-style-type: none"> • Inspect ECU coupler Inspect the wiring harness and couplers for continuity. Defective: repair or replace • Inspect meter coupler Inspect the wiring harness and couplers for continuity. Defective: repair or replace 	

FUEL INJECTION SYSTEM

FI



Symptom	Clock LCD displays "Er-2". (No signals are received from the ECU within the specified duration.)	
Probable malfunction area	<ul style="list-style-type: none"> • Improper operation of communication line • Malfunction in meter • Malfunction in ECU 	
Inspection method 1 Inspection by diagnosis mode	Inspection method 2 Inspection of a malfunction that cannot be identified in the diagnosis mode, and in case the area of the malfunction has been narrowed down in the inspection method 1 given on the left.	
	<ul style="list-style-type: none"> • Inspect ECU coupler Inspect the wiring harness and couplers for continuity. Defective: repair or replace • Inspect meter coupler Inspect the wiring harness and couplers for continuity. Defective: repair or replace 	

Symptom	Clock LCD displays "Er-3". (Data from the ECU cannot be received correctly.)	
Probable malfunction area	<ul style="list-style-type: none"> • Improper operation of communication line • Malfunction in meter • Malfunction in ECU 	
Inspection method 1 Inspection by diagnosis mode	Inspection method 2 Inspection of a malfunction that cannot be identified in the diagnosis mode, and in case the area of the malfunction has been narrowed down in the inspection method 1 given on the left.	
	<ul style="list-style-type: none"> • Inspect ECU coupler Inspect the wiring harness and couplers for continuity. Defective: repair or replace • Inspect meter coupler Inspect the wiring harness and couplers for continuity. Defective: repair or replace 	

Symptom	Clock LCD displays "Er-4". (Non-registered data has been received from the meter.)	
Probable malfunction area	<ul style="list-style-type: none"> • Improper operation of communication line • Malfunction in meter • Malfunction in ECU 	
Inspection method 1 Inspection by diagnosis mode	Inspection method 2 Inspection of a malfunction that cannot be identified in the diagnosis mode, and in case the area of the malfunction has been narrowed down in the inspection method 1 given on the left.	
	<ul style="list-style-type: none"> • Inspect ECU coupler Inspect the wiring harness and couplers for continuity. Defective: repair or replace • Inspect meter coupler Inspect the wiring harness and couplers for continuity. Defective: repair or replace 	

FUEL INJECTION SYSTEM

FI



Symptom	Sidestand switch does not function (the engine does not stop when the stand is extended).	
Probable malfunction area	<ul style="list-style-type: none"> • Short circuit in the input line to ECU • Malfunction in the starter circuit cut-off relay 	
Inspection method 1 Inspection by diagnosis mode	Inspection method 2 Inspection of a malfunction that cannot be identified in the diagnosis mode, and in case the area of the malfunction has been narrowed down in the inspection method 1 given on the left.	
<ul style="list-style-type: none"> • Execute diagnostic code 21 Enable the meter to display the ON/OFF states of the sidestand switch (in gear other than neutral). * To distinguish whether the problem is in the switch or in other areas. 	<ul style="list-style-type: none"> • Meter does not display ON/OFF. Inspect the wiring harness and couplers for continuity. Defective: repair or replace Inspect the sidestand switch. Refer to "CHECKING THE SWITCHES" in chapter 8. Defective: replace 	

Symptom	Engine trouble warning light blinks while the start switch is being pressed (to warn that the engine is unable to start).	
Probable malfunction area	<ul style="list-style-type: none"> • Malfunction in Fuel injection system relay • Open circuit in wiring harness • Disconnected battery • Defective crankshaft position sensor • Defective sidestand switch • Tripped lean angle cut-off switch • Open circuit in ignition coil primary line • ECU memory check error 	
Inspection method 1 Inspection by diagnosis mode	Inspection method 2 Inspection of a malfunction that cannot be identified in the diagnosis mode, and in case the area of the malfunction has been narrowed down in the inspection method 1.	
<ul style="list-style-type: none"> • Execute diagnostic code 50 To trip the Fuel injection system relay. • Execute diagnostic code 09 To check the monitor voltage. * To distinguish whether the problem is in the relay or in other areas. 	<ul style="list-style-type: none"> • Fuel injection system relay does not trip. Inspect the coil side of the fuel injection system relay. Refer to "FUEL INJECTION SYSTEM" in chapter 8. Defective: replace Inspect the wiring harness and couplers for continuity. Defective: repair or replace • Normal voltage is not displayed. Inspect the contact side of the fuel injection system relay. Refer to "FUEL INJECTION SYSTEM" in chapter 8. Defective: replace Inspect the wiring harness and couplers for continuity. Defective: repair or replace • If a self-diagnostic code is displayed: Inspect the battery. Defective: replace or recharge Inspect and repair the applicable area of the malfunction. 	

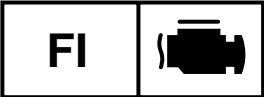

THROTTLE BODIES

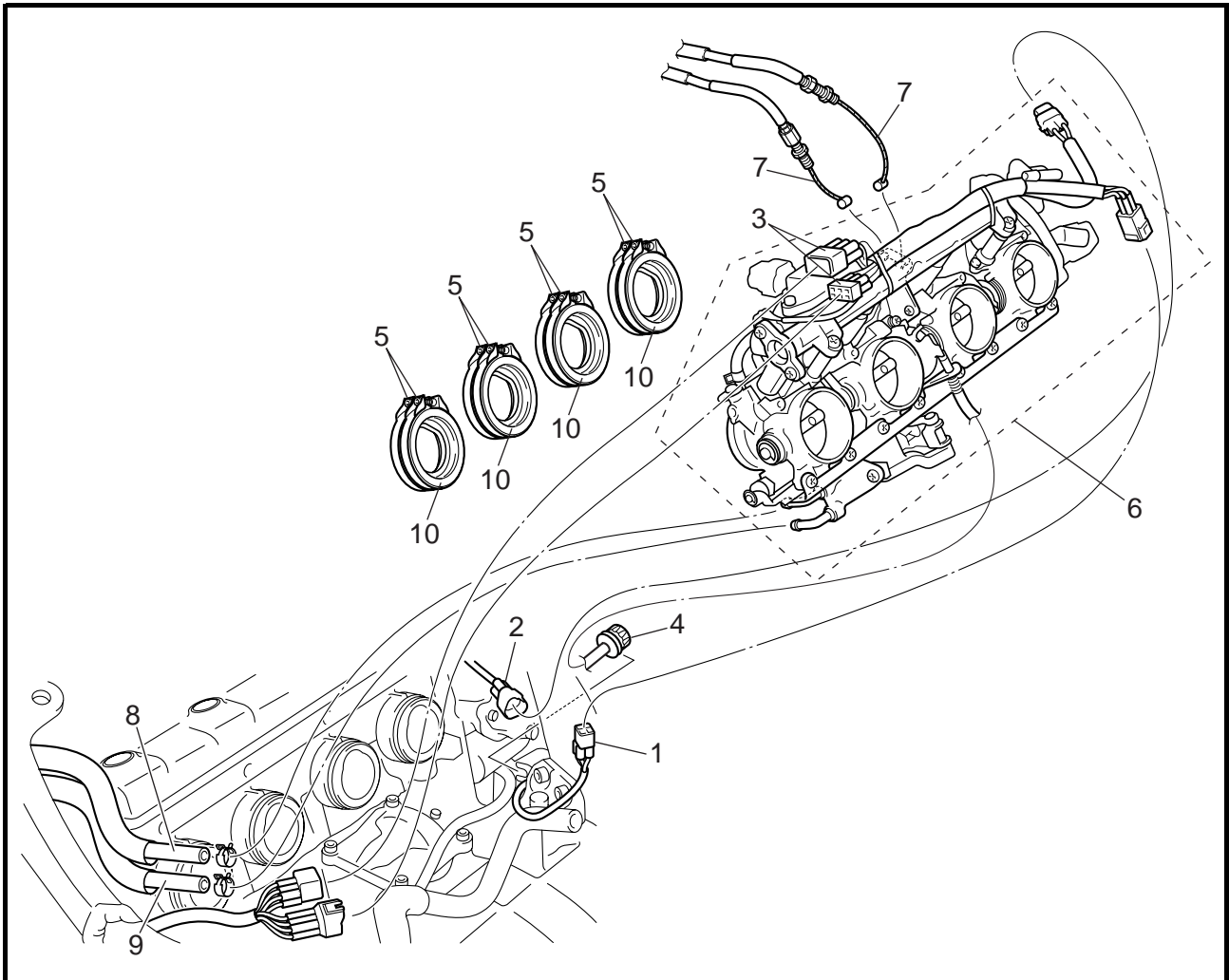

Order	Job/Part	Q'ty	Remarks
	Removing the throttle bodies		Remove the parts in the order listed.
	Seats/fuel tank/T-bar/rubber sheet		Refer to "SEATS AND FUEL TANK" in chapter 3.
	Air filter case		Refer to "AIR FILTER CASE" in chapter 3.
	Coolant		Drain. Refer to "CHANGING THE COOLANT" in chapter 3.
1	O2 sensor coupler	1	Disconnect.
2	Cylinder identification sensor coupler	1	Disconnect.
3	Sub-wire harness 2 coupler	2	Disconnect.
4	Throttle stop screw	1	
5	Throttle body joint clamp screw	8	
6	Throttle bodies	1	

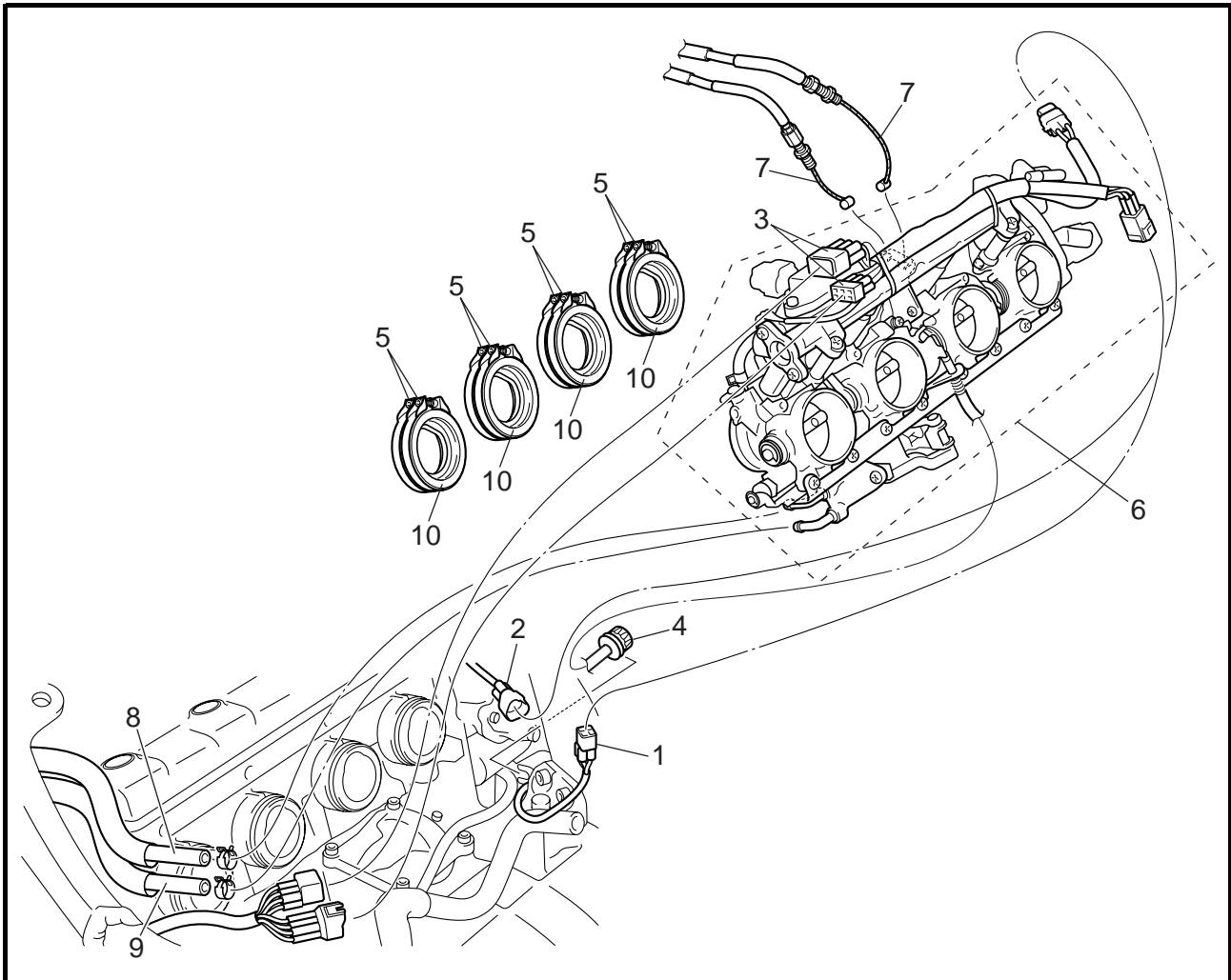

Order	Job/Part	Q'ty	Remarks
7	Throttle cable	2	Disconnect.
8	Plunger control unit hose 1	1	Disconnect.
9	Plunger control unit hose 2	1	Disconnect.
10	Throttle body joint	4	For installation, reverse the removal procedure.

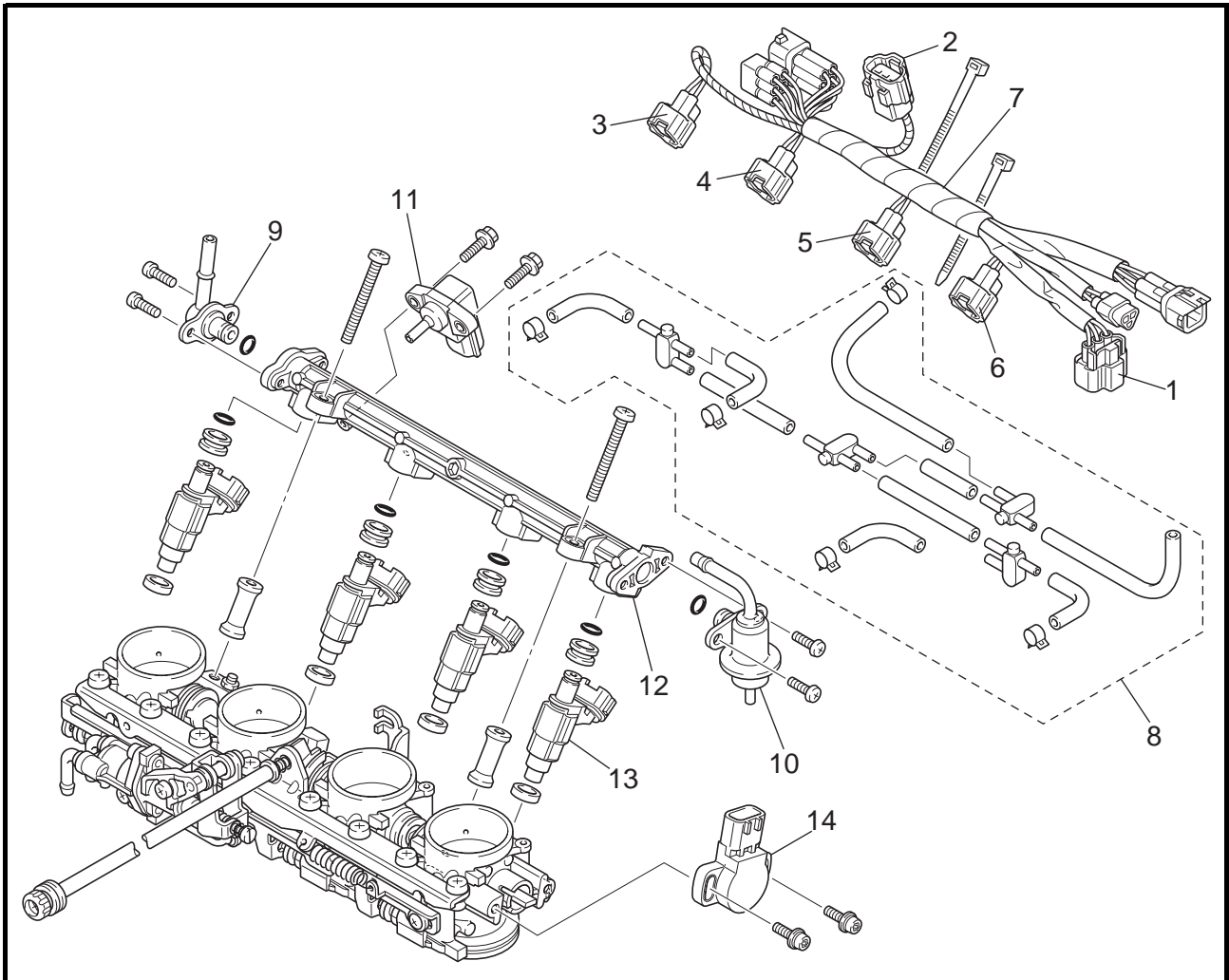
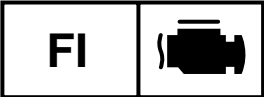

Order	Job/Part	Q'ty	Remarks
	Removing the injector		Remove the parts in the order listed.
1	Throttle position sensor coupler	1	Disconnect.
2	Intake air pressure sensor	1	Disconnect.
3	Cylinder #1-injector coupler	1	Disconnect.
4	Cylinder #2-injector coupler	1	Disconnect.
5	Cylinder #3-injector coupler	1	Disconnect.
6	Cylinder #4-injector coupler	1	Disconnect.
7	Subwire harness 2	1	
8	Negative pressure hose	1	Disconnect.
9	Fuel injection pipe	1	
10	Pressure regulator	1	

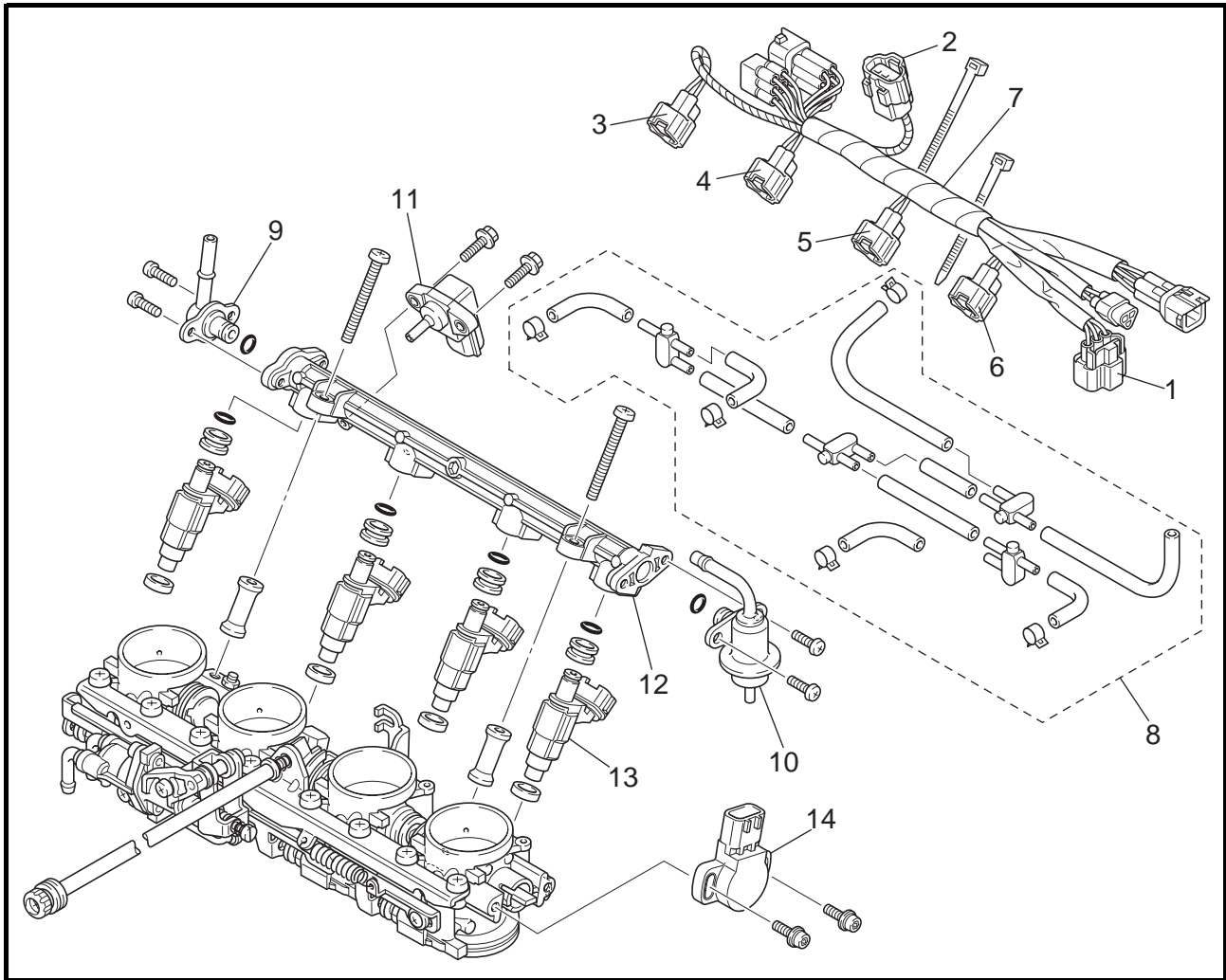
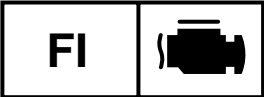

Order	Job/Part	Q'ty	Remarks
11	Intake air pressure sensor	1	For installation, reverse the removal procedure.
12	Fuel distributor	1	
13	Injector	4	
14	Throttle position sensor	1	

FUEL INJECTION SYSTEM

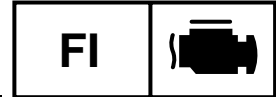

- h. Use the vacuum pressure pump gauge set to adjust the fuel pressure in relation to the vacuum pressure as described below.

NOTE: _____
The vacuum pressure should not exceed 100 kPa (1 mmHg).

Increase the vacuum pressure → Fuel pressure is decreased
Decrease the vacuum pressure → Fuel pressure is increased

Faulty → Replace the pressure regulator.



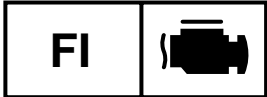

EAS00507

AIR INDUCTION SYSTEM

AIR INJECTION

The air induction system burns unburned exhaust gases by injecting fresh air (secondary air) into the exhaust port, reducing the emission of hydrocarbons.

When there is negative pressure at the exhaust port, the reed valve opens, allowing secondary air to flow into the exhaust port. The required temperature for burning the unburned exhaust gases is approximately 600 to 700 °C.

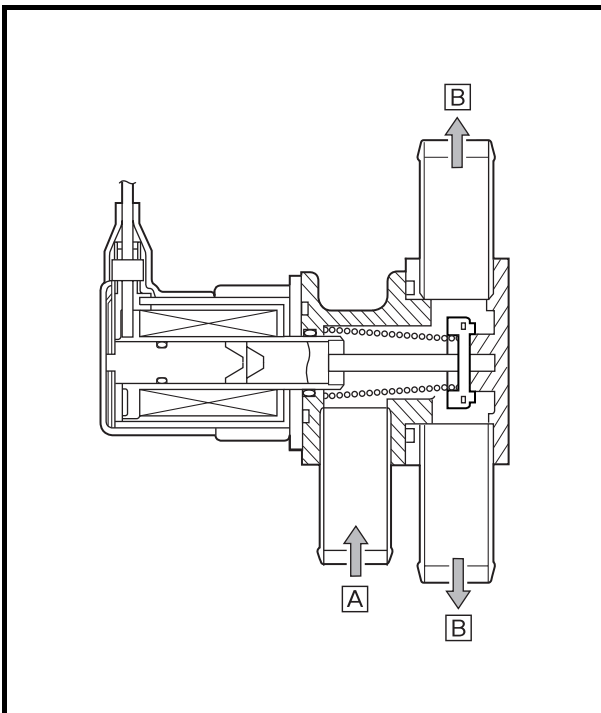

EAS00508

AIR CUT-OFF VALVE

The air cut-off valve is controlled by the signals from the ECU in accordance with the combustion conditions. Ordinarily, the air cut-off valve opens to allow the air to flow during idle and closes to cut-off the flow when the motorcycle is being driven. However, if the coolant temperature is below the specified value, the air cut-off valve remains open and allows the air to flow into the exhaust pipe until the temperature becomes higher than the specified value.

- Ⓐ From the air filter case
- Ⓑ To the reed valve

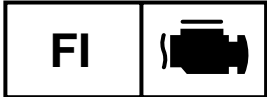

EAS00509

AIR INDUCTION SYSTEM DIAGRAMS

- ① Air cut-off valve
- ② Reed valve
- ③ Air-filter case

- A To cylinder #4
- B To cylinder #3
- C To cylinder #2
- D To cylinder #1

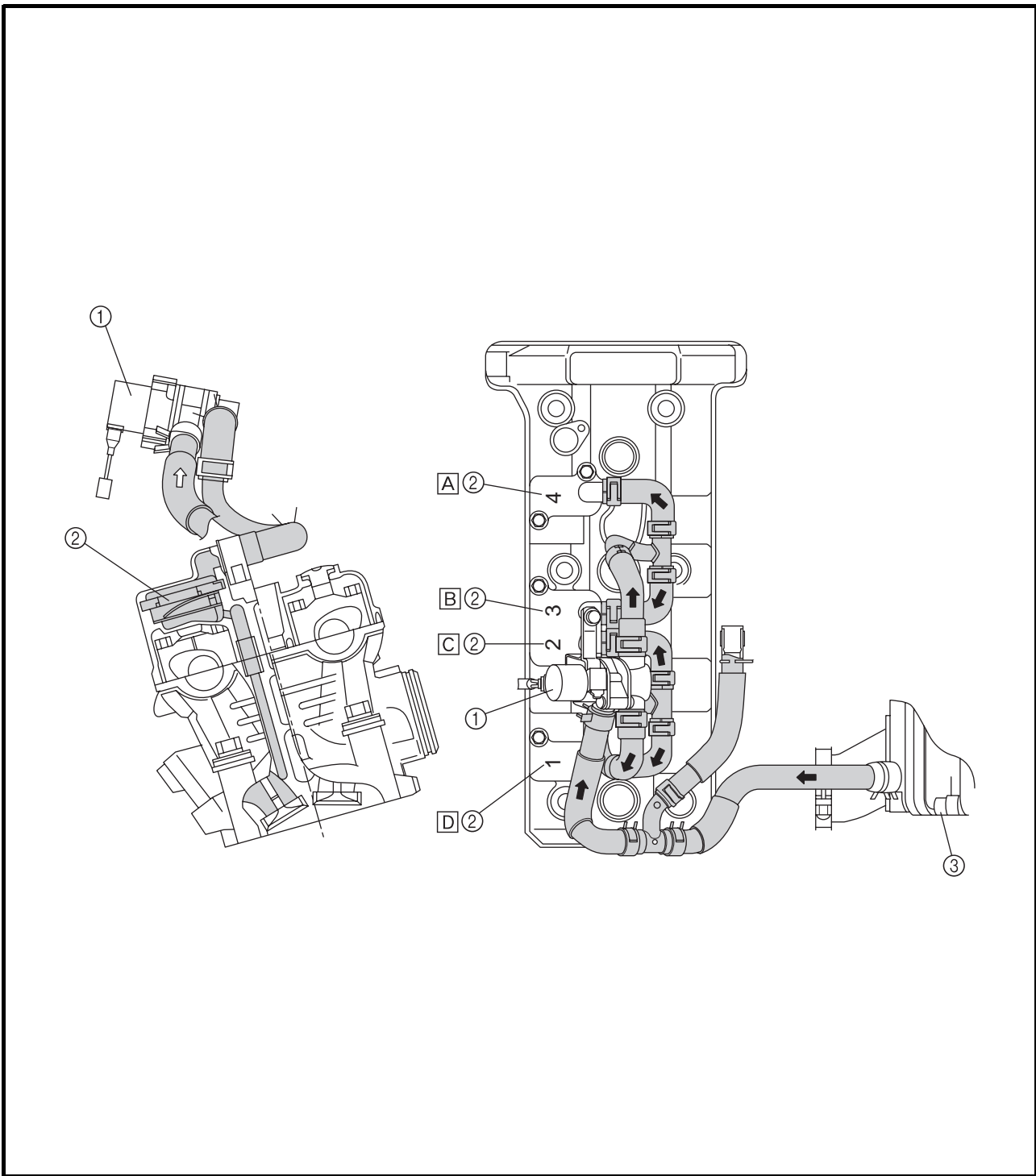

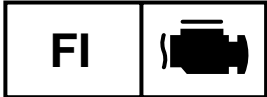

AIR CUT-OFF VALVE ASSEMBLY AND AIR INDUCTION SYSTEM HOSES

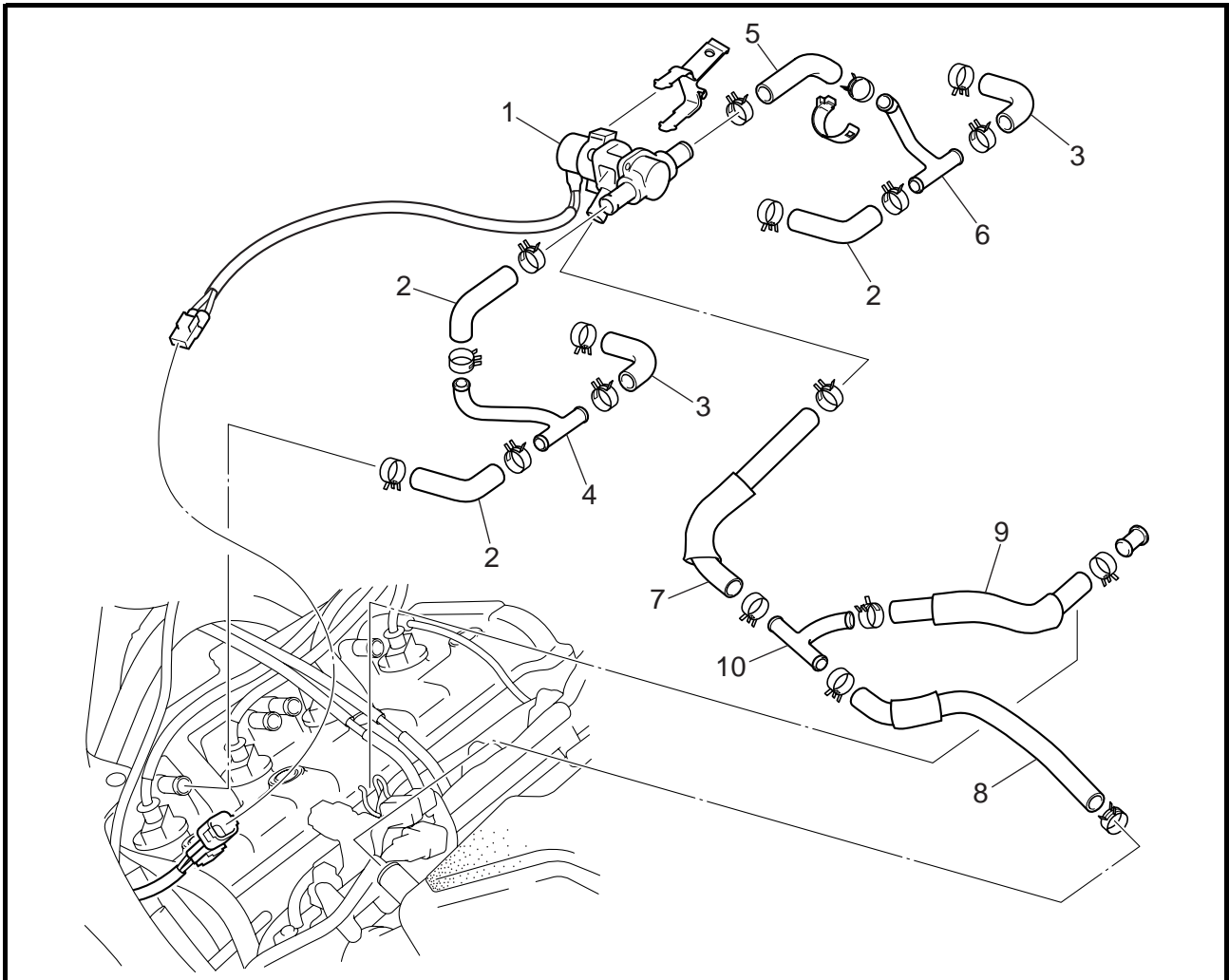

Order	Job/Part	Q'ty	Remarks
	Removing the air cut-off valve assembly and hoses		Remove the parts in the order listed.
	Rider seat/fuel tank/T-bar/rubber sheet		Refer to "SEATS AND FUEL TANK" in chapter 3.
1	Air cut-off valve assembly	1	
2	Hose 1	3	
3	Hose 2	2	
4	Pipe 1	1	
5	Hose 3	1	
6	Pipe 2	1	
7	Hose 4	1	
8	Hose 5	1	
9	Resonator hose	1	
10	Pipe 3	1	
			For installation, reverse the removal procedure.

REED VALVES

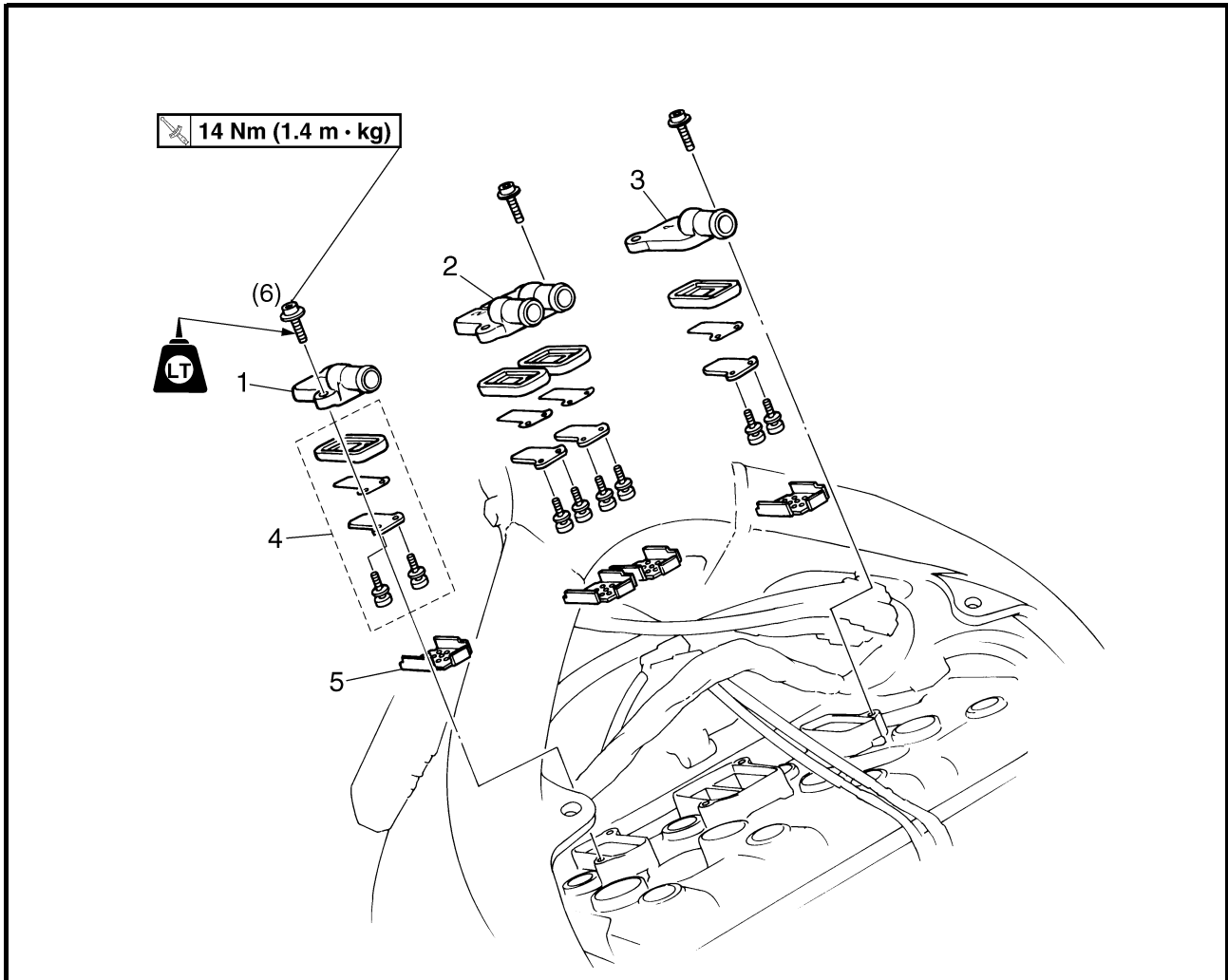

Order	Job/Part	Q'ty	Remarks
	Removing the reed valves		Remove the parts in the order listed.
	Air cut-off valve assembly/hoses		
	Thermostat assembly		Refer to "THERMOSTAT" in chapter 6.
	Spark plug caps		
1	Reed valve cover (1)	1	
2	Reed valve cover (2, 3)	1	
3	Reed valve cover (4)	1	
4	Reed valve assembly	4	
5	Plate	4	
			For installation, reverse the removal procedure.



EAS00510

CHECKING THE AIR INDUCTION SYSTEM

1. Check:

- hoses
Loose connection → Connect properly.
Cracks/damage → Replace.
- pipes
Cracks/damage → Replace.

2. Check:

- fibre reed
- fibre reed stopper
- reed valve seat
Cracks/damage → Replace the reed valve assembly.

3. Check:

- air cut-off valve
Cracks/damage → Replace.

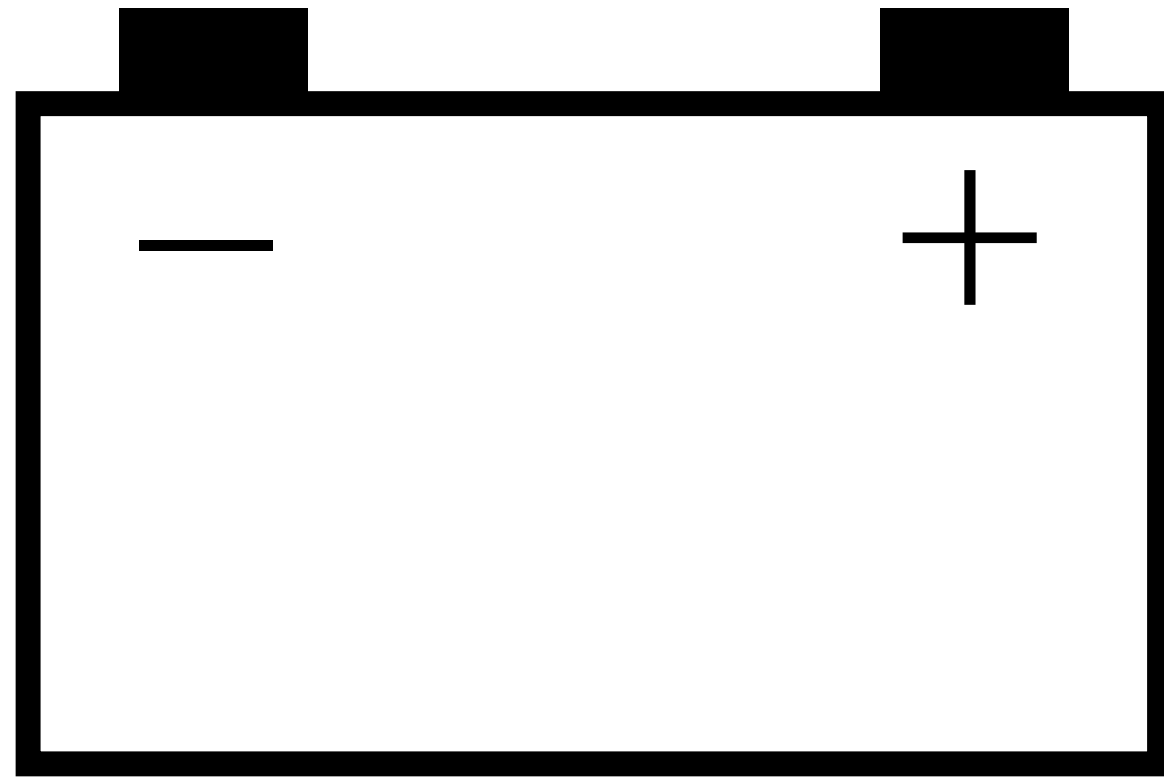

ELEC

88

CHAPTER 8 ELECTRICAL

ELECTRICAL COMPONENTS	8-1
CHECKING SWITCH CONTINUITY	8-3
CHECKING THE SWITCHES	8-5
CHECKING THE BULBS AND BULB SOCKETS	8-7
TYPES OF BULBS.....	8-7
CHECKING THE CONDITION OF THE BULBS.....	8-7
CHECKING THE CONDITION OF THE BULB SOCKETS.....	8-9
IGNITION SYSTEM	8-10
CIRCUIT DIAGRAM.....	8-10
TROUBLESHOOTING.....	8-11
ELECTRIC STARTING SYSTEM	8-15
CIRCUIT DIAGRAM.....	8-15
STARTING CIRCUIT CUT-OFF SYSTEM OPERATION.....	8-16
TROUBLESHOOTING.....	8-17
STARTER MOTOR	8-21
CHECKING THE STARTER MOTOR.....	8-24
ASSEMBLING THE STARTER MOTOR.....	8-26
CHARGING SYSTEM	8-27
CIRCUIT DIAGRAM.....	8-27
TROUBLESHOOTING.....	8-28
LIGHTING SYSTEM	8-30
CIRCUIT DIAGRAM.....	8-30
TROUBLESHOOTING.....	8-31
CHECKING THE LIGHTING SYSTEM.....	8-33
SIGNALING SYSTEM	8-37
CIRCUIT DIAGRAM.....	8-37
TROUBLESHOOTING.....	8-39
CHECKING THE SIGNALING SYSTEM.....	8-40
COOLING SYSTEM	8-47
CIRCUIT DIAGRAM.....	8-47
TROUBLESHOOTING.....	8-48

FUEL INJECTION SYSTEM	8-52
CIRCUIT DIAGRAM	8-52
TROUBLESHOOTING	8-53
CHECKING THE FUEL PUMP	8-59
CHECKING AND ADJUSTING THE THROTTLE POSITION SENSOR .	8-60
WINDSHIELD DRIVE SYSTEM	8-64
CIRCUIT DIAGRAM	8-64
TROUBLESHOOTING	8-65

EAS00729

ELECTRICAL

ELECTRICAL COMPONENTS

- ① Windshield drive unit
- ② Battery
- ③ Starter relay
- ④ Fuel injection system fuse
- ⑤ Front brake switch
- ⑥ Clutch switch
- ⑦ Fuse box
- ⑧ Radiator fan motor
- ⑨ Wire harness
- ⑩ Neutral switch
- ⑪ Sidestand switch
- ⑫ Oil level switch
- ⑬ Rear brake switch
- ⑭ Horn
- ⑮ Ignition coil
- ⑯ Main fuse

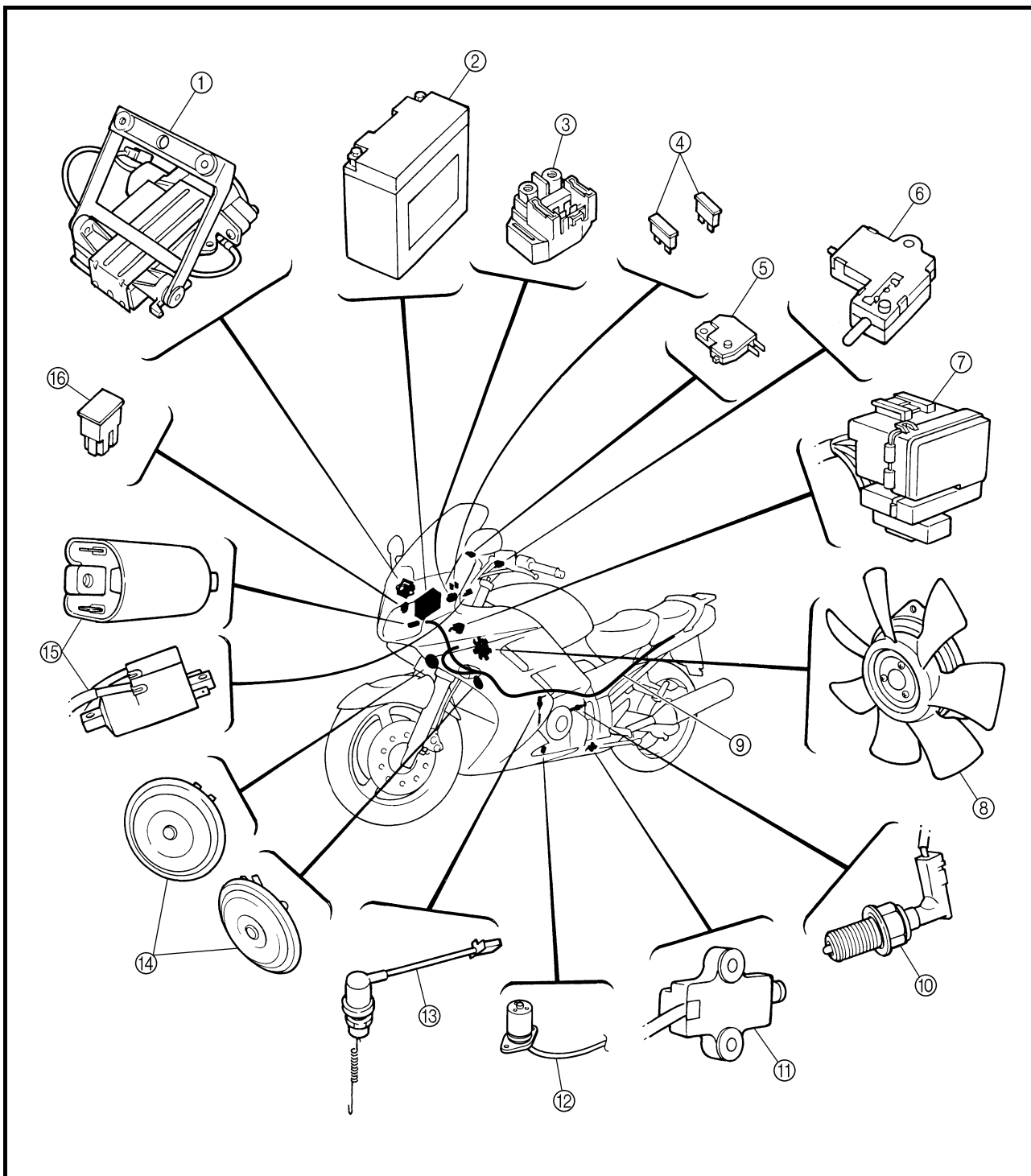

ELECTRICAL COMPONENTS

ELEC

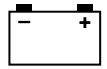

- ① Coolant temperature sensor
- ② Intake air pressure sensor
- ③ Intake air temperature sensor
- ④ Atmospheric pressure sensor
- ⑤ Lean angle cut-off switch
- ⑥ ECU
- ⑦ Starting circuit cut-off relay
- ⑧ Speed sensor
- ⑨ Cylinder identification sensor
- ⑩ O₂ sensor
- ⑪ Crankshaft position sensor
- ⑫ Headlight relay 1
- ⑬ Headlight relay 2
- ⑭ Fuel injection system relay
- ⑮ Turn signal relay
- ⑯ Radiator fan motor relay

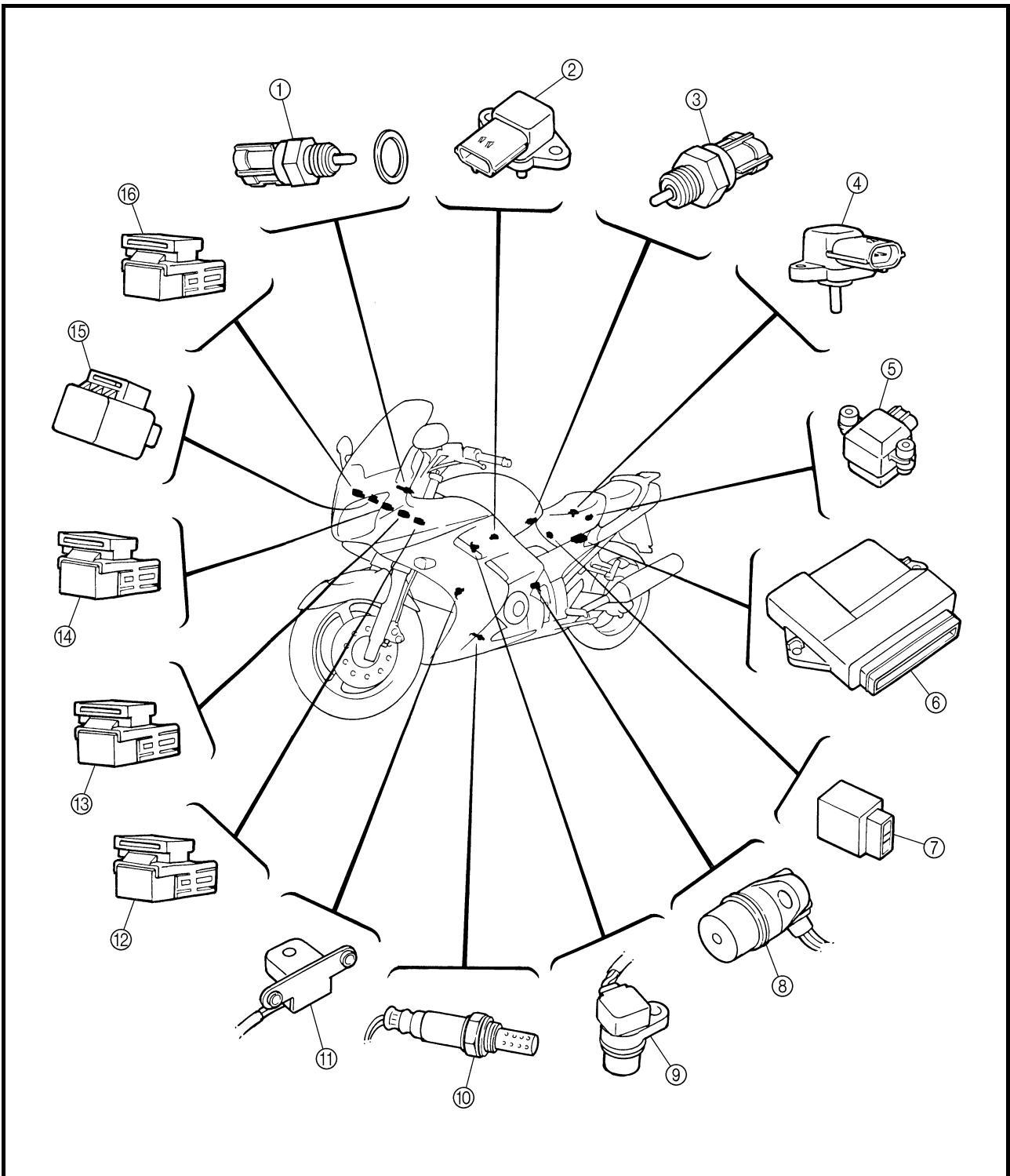

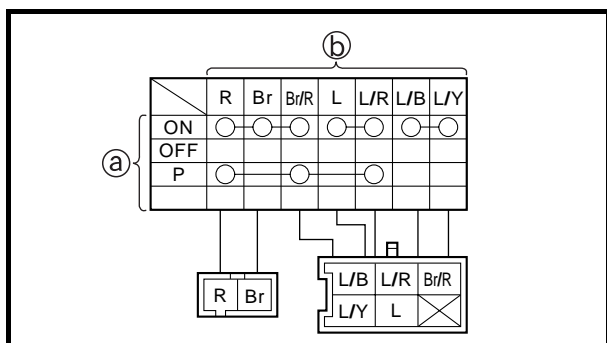
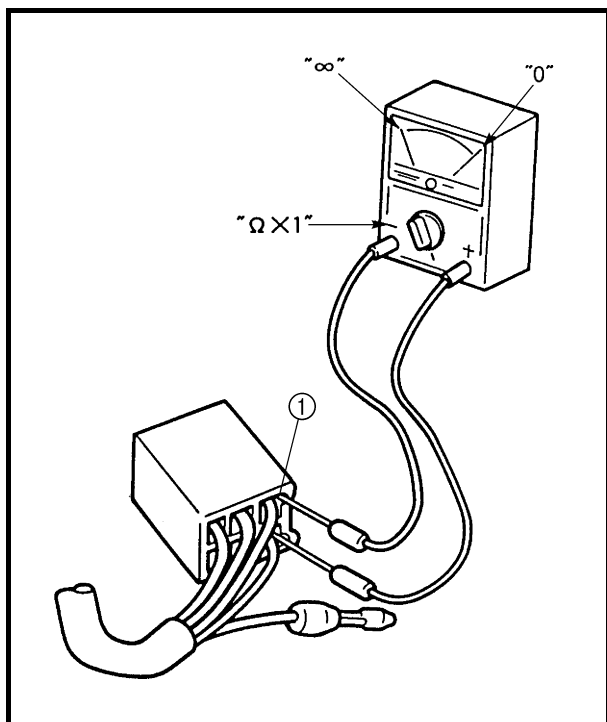

EAS00730

CHECKING SWITCH CONTINUITY

Check each switch for continuity with the pocket tester. If the continuity reading is incorrect, check the wiring connections and if necessary, replace the switch.

CAUTION:

Never insert the tester probes into the coupler terminal slots ①. Always insert the probes from the opposite end of the coupler, taking care not to loosen or damage the leads.



Pocket tester
90890-03112

NOTE:

- Before checking for continuity, set the pocket tester to "0" and to the "Ω × 1" range.
- When checking for continuity, switch back and forth between the switch positions a few times.

The terminal connections for switches (e.g., main switch, engine stop switch) are shown in an illustration similar to the one on the left.

The switch positions ① are shown in the far left column and the switch lead colors ② are shown in the top row in the switch illustration.

NOTE:

"○—○" indicates a continuity of electricity between switch terminals (i.e., a closed circuit at the respective switch position).

The example illustration on the left shows that:

There is continuity between red, brown/red and blue/red when the switch is set to "P".

There is continuity between red, brown and brown/red, between blue and blue/red, between blue/black and blue/yellow when the switch is set to "ON".

CHECKING SWITCH CONTINUITY

ELEC

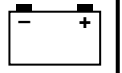

EAS00731

CHECKING THE SWITCHES

Check each switch for damage or wear, proper connections, and also for continuity between the terminals. Refer to "CHECKING SWITCH CONTINUITY".

Damage/wear → Repair or replace.

Improperly connected → Properly connect.

Incorrect continuity reading → Replace the switch.

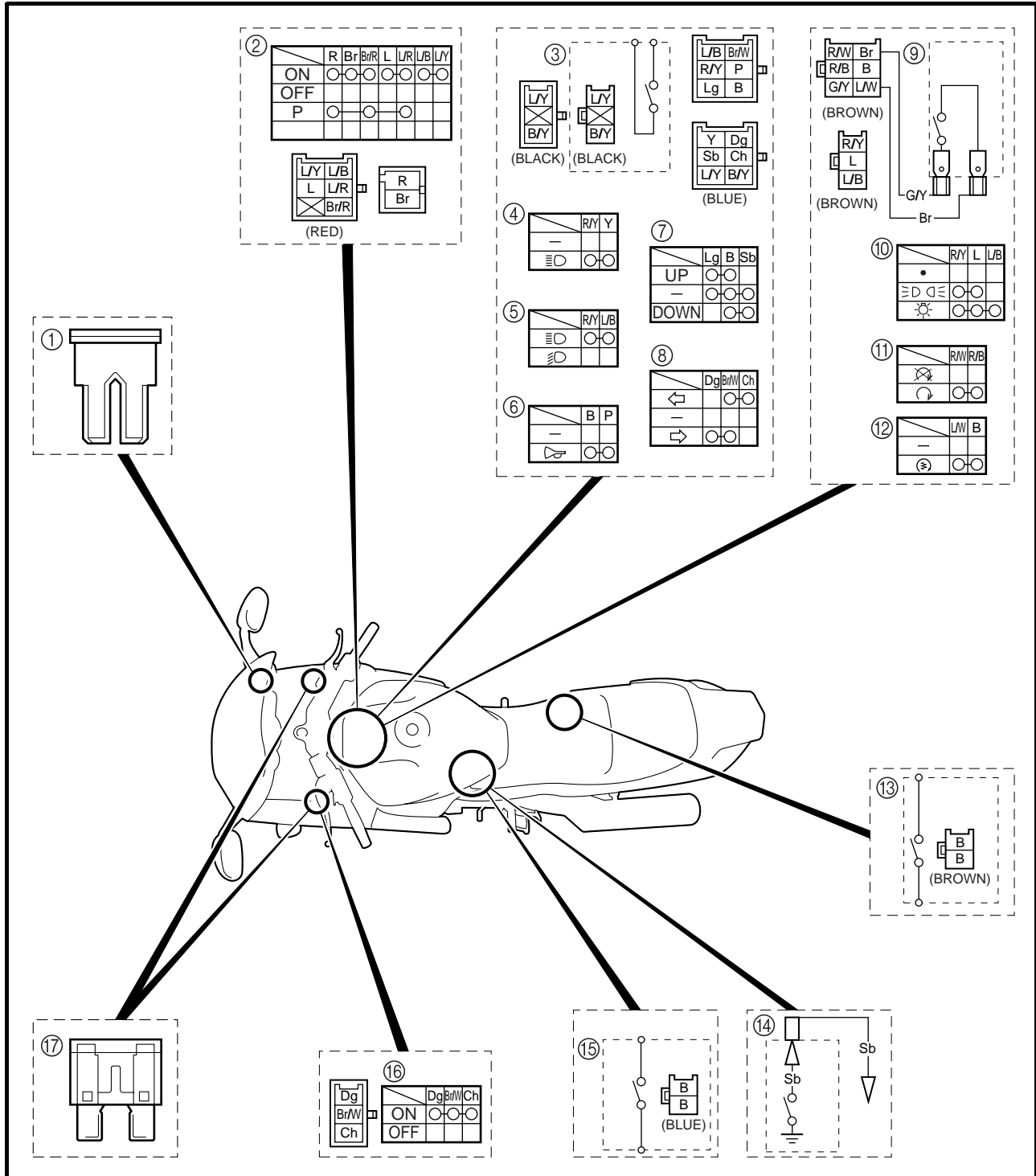

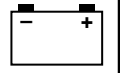

- ① Main fuse
- ② Main switch
- ③ Clutch switch
- ④ Pass switch
- ⑤ Dimmer switch
- ⑥ Horn switch
- ⑦ Windshield position switch
- ⑧ Turn signal switch
- ⑨ Front brake light switch
- ⑩ Light switch
- ⑪ Engine stop switch
- ⑫ Start switch
- ⑬ Rear brake light switch
- ⑭ Neutral switch
- ⑮ Sidestand switch
- ⑯ Hazard switch
- ⑰ Fuse

EAS00732

CHECKING THE BULBS AND BULB SOCKETS

Check each bulb and bulb socket for damage or wear, proper connections, and also for continuity between the terminals.

Damage/wear → Repair or replace the bulb, bulb socket or both.

Improperly connected → Properly connect.

No continuity → Repair or replace the bulb, bulb socket or both.

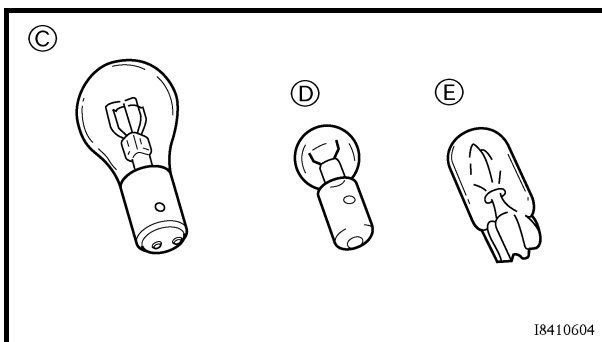
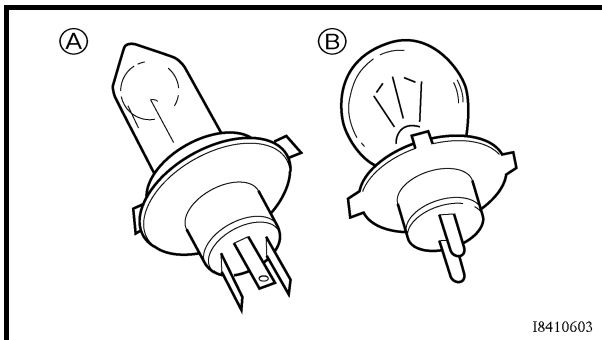

TYPES OF BULBS

The bulbs used on this motorcycle are shown in the illustration on the left.

- Bulbs ① and ② are used for the headlights and usually use a bulb holder that must be detached before removing the bulb. The majority of these types of bulbs can be removed from their respective socket by turning them counterclockwise.
- Bulbs ③ is used for turn signal and tail/brake lights and can be removed from the socket by pushing and turning the bulb counterclockwise.
- Bulbs ④ and ⑤ are used for meter and indicator lights and can be removed from their respective socket by carefully pulling them out.

CHECKING THE CONDITION OF THE BULBS

The following procedure applies to all of the bulbs.

1. Remove:
 - bulb

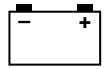

EAS00735

IGNITION SYSTEM CIRCUIT DIAGRAM

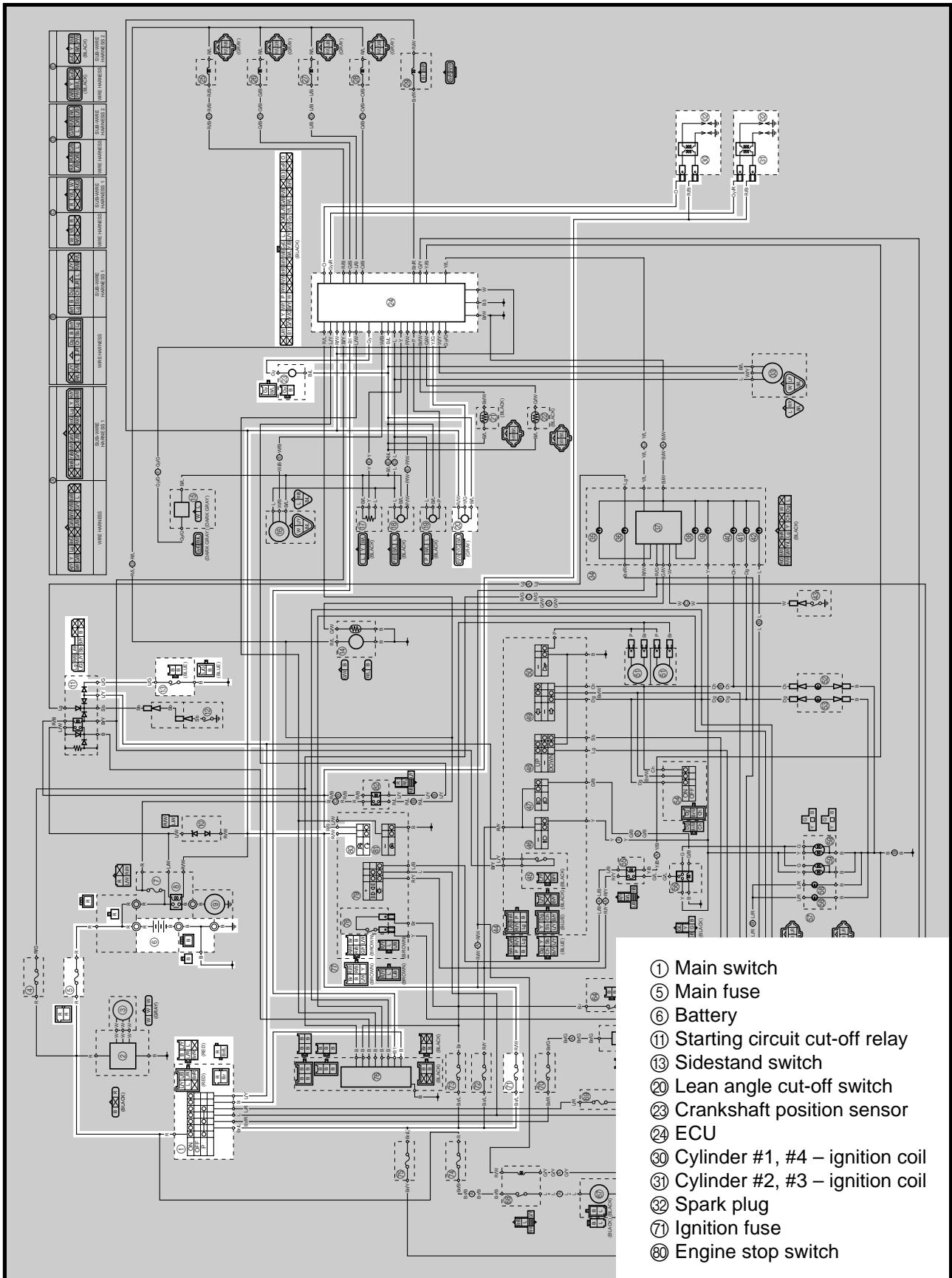

- ① Main switch
- ⑤ Main fuse
- ⑥ Battery
- ⑪ Starting circuit cut-off relay
- ⑬ Sidestand switch
- ⑳ Lean angle cut-off switch
- ㉓ Crankshaft position sensor
- ㉔ ECU
- ㉚ Cylinder #1, #4 – ignition coil
- ㉛ Cylinder #2, #3 – ignition coil
- ㉜ Spark plug
- ㉟ Ignition fuse
- ㉠ Engine stop switch

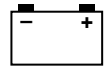

EAS00737

TROUBLESHOOTING

The ignition system fails to operate (no spark or intermittent spark).

Procedure

Check:

1. main and ignition fuses
2. battery
3. spark plugs
4. ignition spark gap
5. spark plug cap resistance
6. ignition coil resistance
7. crankshaft position sensor resistance
8. main switch
9. engine stop switch
10. neutral switch
11. sidestand switch
12. starting circuit cut-off relay
13. wiring connections
(of the entire ignition system)

NOTE:

- Before troubleshooting, remove the following part(s):
 - 1) Seat
 - 2) Fuel tank and T-bar
 - 3) Side cowlings
 - 4) Front cowlng assembly
 - 5) Air filter case
- Troubleshoot with the following special tool(s).



Ignition checker
90890-06754
Pocket tester
90890-03112

EAS00738

1. Main and ignition fuses
 - Check the main and ignition fuses for continuity.
Refer to "CHECKING THE FUSES" in chapter 3.
 - Are the main and ignition fuses OK?

↓ YES

↓ NO

Replace the fuse(s).

EAS00739

2. Battery

- Check the condition of the battery.
Refer to "CHECKING AND CHARGING THE BATTERY" in chapter 3.



Minimum open-circuit voltage
12.8 V or more at 20 °C

- Is the battery OK?

↓ YES

↓ NO

- Clean the battery terminals.
- Recharge or replace the battery.

EAS00741

3. Spark plugs

The following procedure applies to all of the spark plugs.

- Check the condition of the spark plug.
- Check the spark plug type.
- Measure the spark plug gap.
Refer to "CHECKING THE SPARK PLUGS" in chapter 3.



Standard spark plug
CR8E (NGK)
U24ESR-N (DENSO)
Spark plug gap
0.7 ~ 0.8 mm

- Is the spark plug in good condition, is it of the correct type, and is its gap within specification?

↓ YES

↓ NO

Re-gap or replace the spark plug.

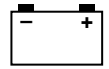

EAS00743

4. Ignition spark gap

The following procedure applies to all of the spark plugs. Disconnect the spark plug cap from the spark plug.

- Disconnect the spark plug cap from the spark plug.
- Connect the ignition checker ① as shown.
- ② Spark plug cap
- Set the main switch to “ON”.
- Measure the ignition spark gap ③.
- Crank the engine by pushing the starter switch and gradually increase the spark gap until a misfire occurs.

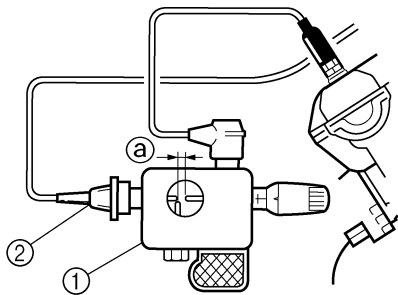

I8110202



**Minimum ignition spark gap
6.0 mm**

- Is there a spark and is the spark gap within specification?

NO

YES

The ignition system is OK.

EAS00745

5. Spark plug cap resistance

The following procedure applies to all of the spark plug caps.

- Remove the spark plug cap from the spark plug lead.
- Connect the pocket tester ($\Omega \times 1k$) to the spark plug cap as shown.
- Measure the spark plug cap resistance.

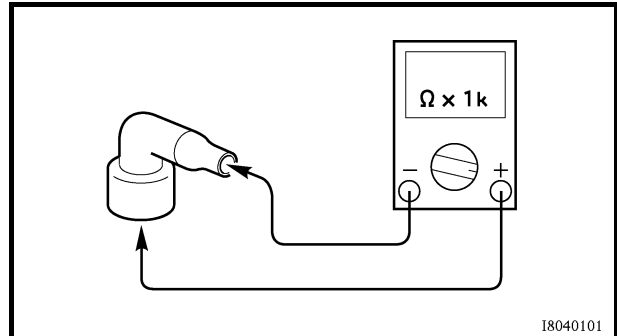

I8040101



**Spark plug cap resistance
10 k Ω at 20 °C**

- Is the spark plug cap OK?

YES

NO

Replace the spark plug cap.

EAS00747

6. Ignition coil resistance

The following procedure applies to all of the ignition coils.

- Disconnect the ignition coil leads from the wire harness.
- Connect the pocket tester ($\Omega \times 1$) to the ignition coil as shown.

Tester positive probe → red/black

Tester negative probe → orange (gray/red)

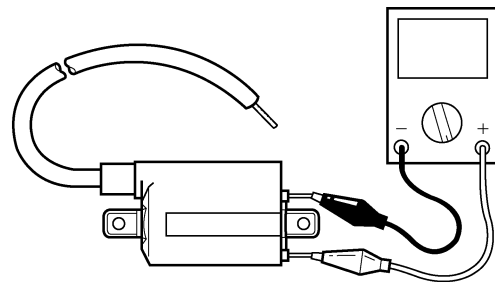

I8110104

- Measure the primary coil resistance.



**Primary coil resistance
1.53 ~ 2.07 Ω at 20 °C**

- Connect the pocket tester ($\Omega \times 1k$) to the ignition coil as shown.

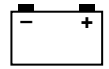

Tester negative probe → spark plug lead ①
 Tester positive probe → spark plug lead ②

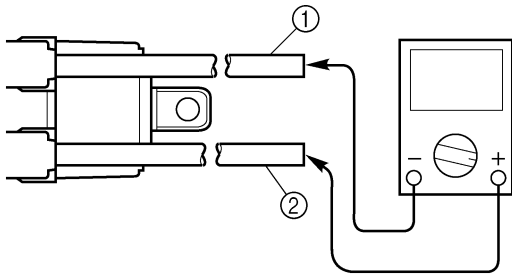

18110102

• Measure the secondary coil resistance.



Secondary coil resistance
 12 ~ 18 kΩ at 20 °C

• Is the ignition coil OK?



Replace the ignition coil.

EAS00748

7. Crankshaft position sensor resistance

- Disconnect the crankshaft position sensor coupler from the wire harness.
- Connect the pocket tester ($\Omega \times 100$) to the crankshaft position sensor coupler as shown.

Tester positive probe → gray ①
 Tester negative probe → black ②

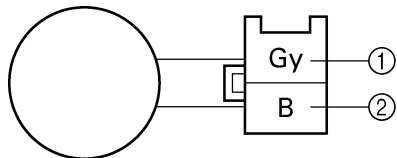

• Measure the crankshaft position sensor resistance.

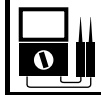

Crankshaft position sensor resistance
 420 ~ 569 Ω at 20 °C
 (between gray and black)

• Is the crankshaft position sensor OK?



Replace the crankshaft position sensor.

EAS00749

8. Main switch

- Check the main switch for continuity. Refer to "CHECKING THE SWITCHES".
- Is the main switch OK?



Replace the main switch.

EAS00750

9. Engine stop switch

- Check the engine stop switch for continuity. Refer to "CHECKING THE SWITCHES".
- Is the engine stop switch OK?



Replace the right handlebar switch.

EAS00751

10. Neutral switch

- Check the neutral switch for continuity. Refer to "CHECKING THE SWITCHES".
- Is the neutral switch OK?



Replace the neutral switch.

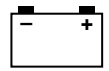

EAS00752

11. Sidestand switch

- Check the sidestand switch for continuity. Refer to "CHECKING THE SWITCHES".
- Is the sidestand switch OK?



Replace the side-stand switch.

EAS00753

12. Starting circuit cut-off relay

- Disconnect the starting circuit cut-off relay from the wire harness.
- Connect the pocket tester ($\Omega \times 1$) to the starting circuit cut-off relay terminals as shown.
- Check the starting circuit cut-off relay for continuity.

Tester positive probe → blue/green ①	Continuity
Tester negative probe → blue/yellow ②	
Tester positive probe → blue/yellow ①	No continuity
Tester negative probe → blue/green ②	

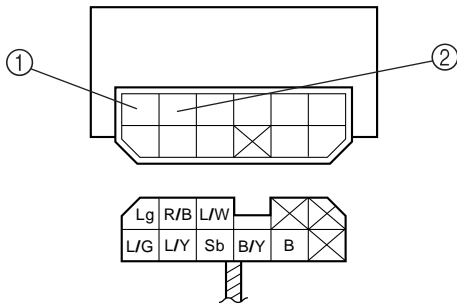

NOTE:

When you switch the positive and negative tester probes, the readings in the above chart will be reversed.

- Are the tester readings correct?



Replace the starting circuit cut-off relay.

EAS00754

13. Wiring

- Check the entire ignition system's wiring. Refer to "CIRCUIT DIAGRAM".
- Is the ignition system's wiring properly connected and without defects?



Replace the ECU.

Properly connect or repair the ignition system's wiring.

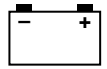

EAS00755

ELECTRIC STARTING SYSTEM CIRCUIT DIAGRAM

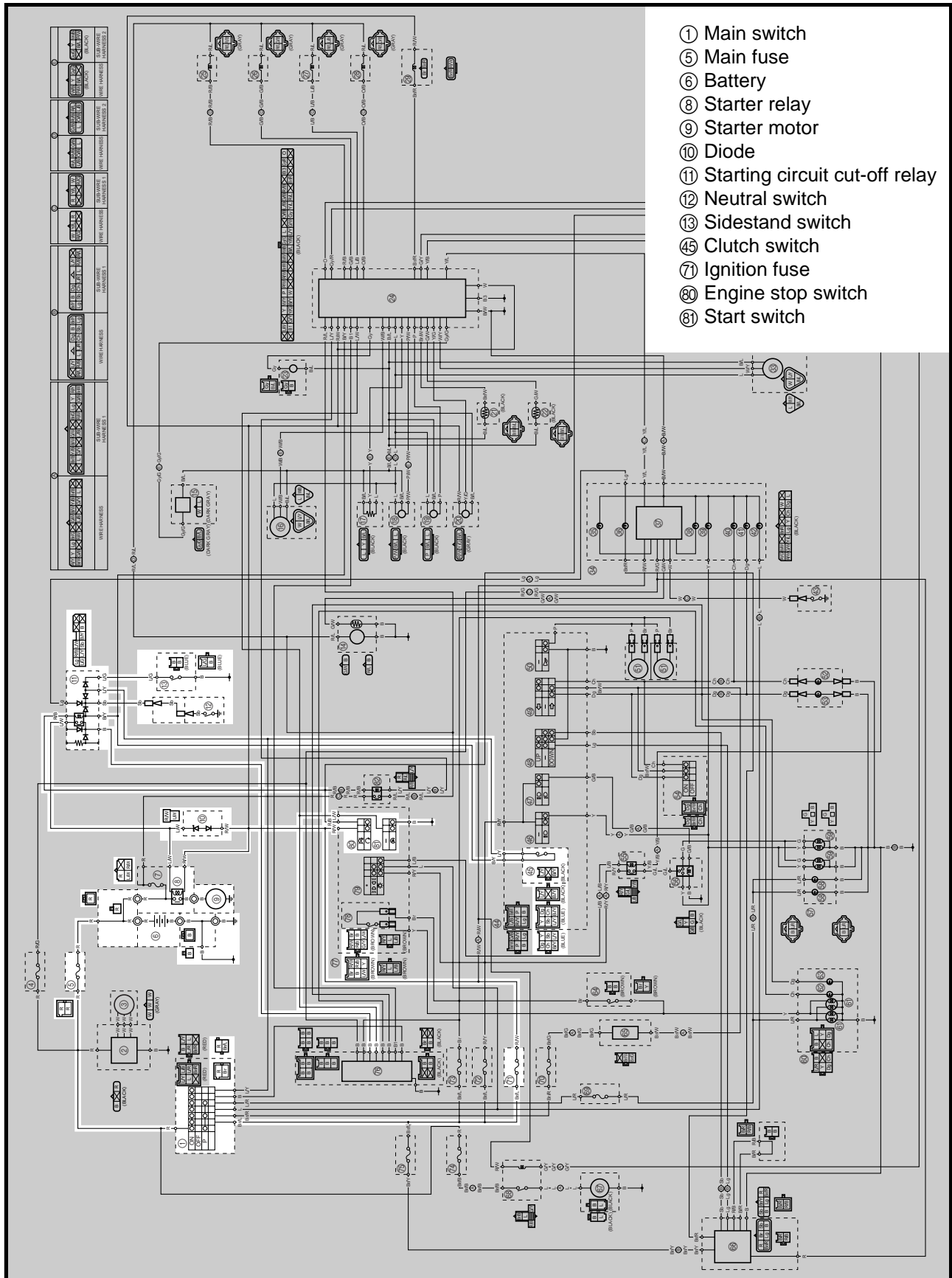

- ① Main switch
- ⑤ Main fuse
- ⑥ Battery
- ⑧ Starter relay
- ⑨ Starter motor
- ⑩ Diode
- ⑪ Starting circuit cut-off relay
- ⑫ Neutral switch
- ⑬ Sidestand switch
- ④⑤ Clutch switch
- ⑦ Ignition fuse
- ⑧⑩ Engine stop switch
- ⑧① Start switch

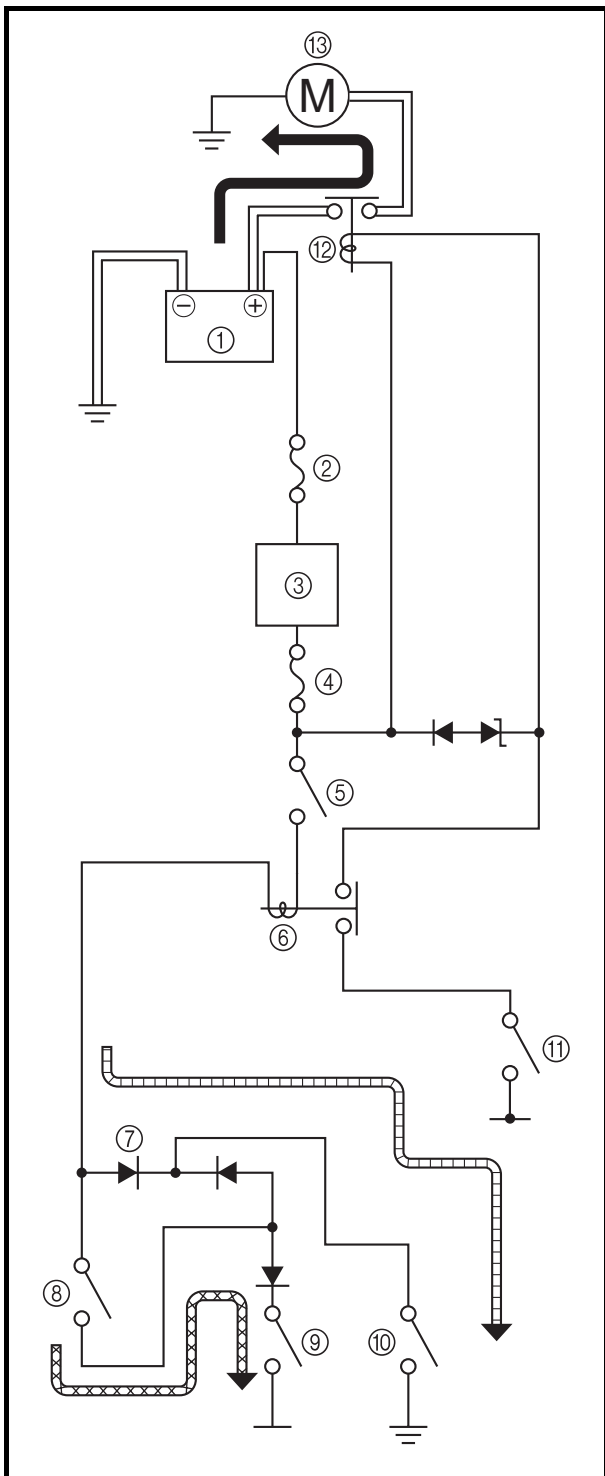



EAS00756

STARTING CIRCUIT CUT-OFF SYSTEM OPERATION

If the engine stop switch is set to “○” and the main switch is set to “ON” (both switches are closed), the starter motor can only operate if at least one of the following conditions is met:

- The transmission is in neutral (the neutral switch is closed).
- The clutch lever is pulled to the handlebar (the clutch switch is closed) and the side-stand is up (the sidestand switch is closed).

The starting circuit cut-off relay prevents the starter motor from operating when neither of these conditions has been met. In this instance, the starting circuit cut-off relay is open so current cannot reach the starter motor. When at least one of the above conditions has been met the starting circuit cut-off relay is closed and the engine can be started by pressing the starter switch.

- ←  WHEN THE TRANSMISSION IS IN NEUTRAL
- ←  WHEN THE SIDESTAND IS UP AND THE CLUTCH LEVER IS PULLED TO THE HANDLEBAR

- ① Battery
- ② Main fuse
- ③ Main switch
- ④ Ignition fuse
- ⑤ Engine stop switch
- ⑥ Starting circuit cut-off relay
- ⑦ Diode (starting circuit cut-off relay)
- ⑧ Clutch switch
- ⑨ Sidestand switch
- ⑩ Neutral switch
- ⑪ Start switch
- ⑫ Starter relay
- ⑬ Starter motor

EAS00757

TROUBLESHOOTING

The starter motor fails to turn.

Check:

1. main and ignition fuses
2. Battery
3. starter motor
4. starting circuit cut-off relay
5. starter circuit cut-off relay (diode)
6. starter relay
7. main switch
8. engine stop switch
9. neutral switch
10. sidestand switch
11. clutch switch
12. start switch
13. wiring connections
(of the entire starting system)

NOTE:

- Before troubleshooting, remove the following part(s):
 - 1) seats
 - 2) fuel tank
 - 3) inner panels (front cowling)
 - 4) air filter case
- Troubleshoot with the following special tool(s).



Pocket tester
90890-03112

EAS00738

1. Main and ignition fuses

- Check the main and ignition fuses for continuity. Refer to “CHECKING THE FUSES” in chapter 3.
- Are the main and ignition fuses OK?

↓ YES

↓ NO

Replace the fuse(s).

EAS00739

2. Battery

- Check the condition of the battery. Refer to “CHECKING AND CHARGING THE BATTERY” in chapter 3.



Minimum open-circuit voltage
12.8 V or more at 20 °C

• Is the battery OK?

↓ YES

↓ NO

- Clean the battery terminals.
- Recharge or replace the battery.

EAS00758

3. Starter motor

- Connect the positive battery terminal ① and starter motor lead ② with a jumper lead ③.

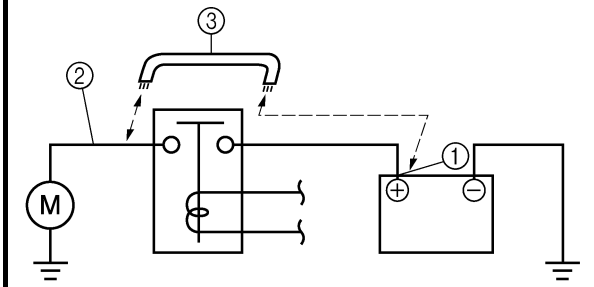

18210801

⚠ WARNING

- A wire that is used as a jumper lead must have at least the same capacity or more as that of the battery lead, otherwise the jumper lead may burn.
- This check is likely to produce sparks, therefore make sure nothing flammable is in the vicinity.

• Does the starter motor turn?

↓ YES

↓ NO

Repair or replace the starter motor.

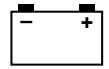

EAS00759

4. Starting circuit cut-off relay

- Disconnect the starting circuit cut-off relay from the wire harness.
- Connect the pocket tester ($\Omega \times 1$) and battery (12 V) to the starting circuit cut-off relay terminals as shown.

Battery positive terminal → red/black ①

Battery negative terminal → black/yellow ②

Tester positive probe → blue/white ③

Tester negative probe → black ④

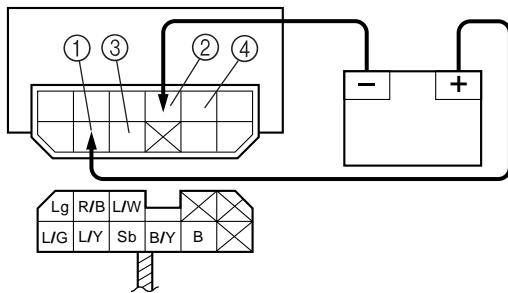

- Does the starting circuit cut-off relay have continuity between blue/white and black?

↓ YES

↓ NO

Replace the starting circuit cut-off relay.

EAS00760

5. Starting circuit cut-off relay (diode)

- Disconnect the starting circuit cut-off relay from the wire harness.
- Connect the pocket tester ($\Omega \times 1$) to the starting circuit cut-off relay terminals as shown.
- Measure the starting circuit cut-off relay for continuity as follows.

Tester positive probe → sky blue ①

Tester negative probe → light green ②

Tester positive probe → sky blue ①

Tester negative probe → black/yellow ③

Tester positive probe → sky blue ①

Tester negative probe → blue/yellow ④

Tester positive probe → blue/green ⑤

Tester negative probe → blue/yellow ④

Tester positive probe → light green ②

Tester negative probe → sky blue ①

Tester positive probe → black/yellow ③

Tester negative probe → sky blue ①

Tester positive probe → blue/yellow ④

Tester negative probe → sky blue ①

Tester positive probe → blue/yellow ④

Tester negative probe → blue/green ⑤

Continuity

No continuity

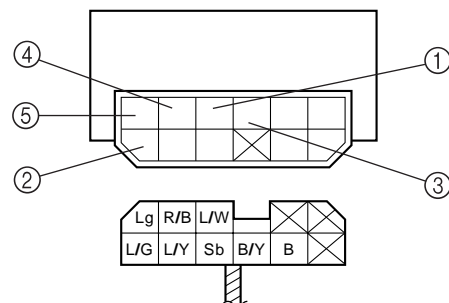

NOTE: _____
When you switch the tester's positive and negative probes, the readings in the above chart will be reversed.

• Are the testing readings correct?



Replace the starting circuit cut-off relay.

EAS00761

6. Starter relay

- Disconnect the starter relay from the coupler.
- Connect the pocket tester ($\Omega \times 1$) and battery (12 V) to the starter relay terminals as shown.

Battery positive terminal → red/white ①
Battery negative terminal → blue/white ②

Tester positive probe → red ③
Tester negative probe → black ④

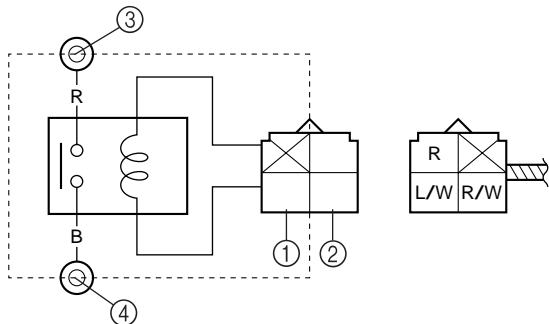

• Does the starter relay have continuity between red and black?



Replace the starter relay.

EAS00749

7. Main switch

- Check the main switch for continuity. Refer to "CHECKING THE SWITCHES".
- Is the main switch OK?



Replace the main switch.

EAS00750

8. Engine stop switch

- Check the engine stop switch for continuity. Refer to "CHECKING THE SWITCHES".
- Is the engine stop switch OK?



Replace the right handlebar switch.

EAS00751

9. Neutral switch

- Check the neutral switch for continuity. Refer to "CHECKING THE SWITCHES".
- Is the neutral switch OK?



Replace the neutral switch.

EAS00752

10. Sidestand switch

- Check the sidestand switch for continuity. Refer to "CHECKING THE SWITCHES".
- Is the sidestand switch OK?



Replace the side-stand switch.

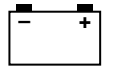

EAS00763

11. Clutch switch

- Check the clutch switch for continuity. Refer to "CHECKING THE SWITCHES".
- Is the clutch switch OK?



Replace the clutch switch.

EAS00764

12. Start switch

- Check the start switch for continuity. Refer to "CHECKING THE SWITCHES".
- Is the start switch OK?



Replace the right handlebar switch.

EAS00766

13. Wiring

- Check the entire starting system's wiring. Refer to "CIRCUIT DIAGRAM".
- Is the starting system's wiring properly connected and without defects?



Replace the ECU.

Properly connect or repair the starting system's wiring.

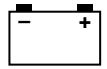

EAS00767

STARTER MOTOR

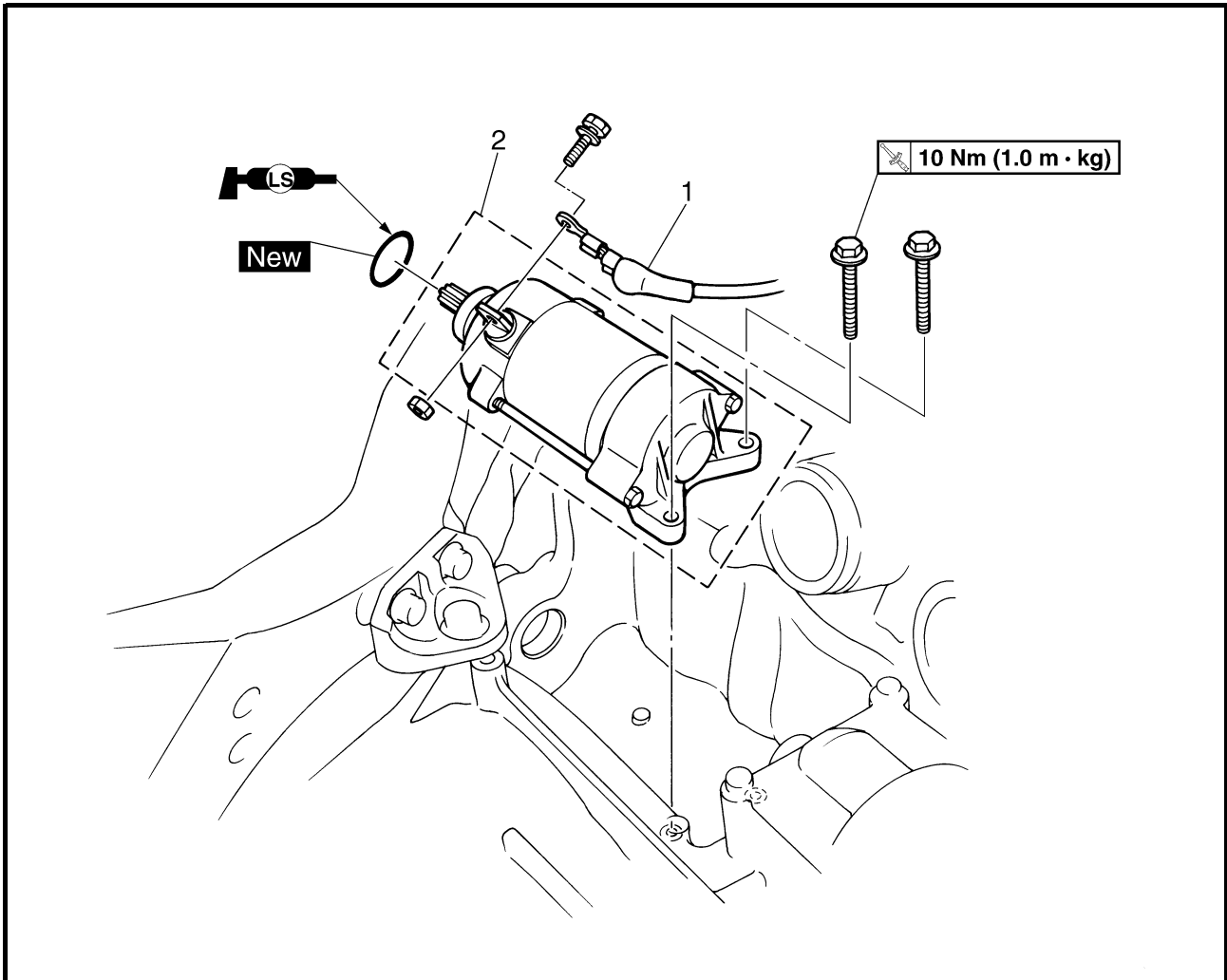

Order	Job/Part	Q'ty	Remarks
	Removing the starter motor		Remove the parts in the order listed.
	Throttle bodies		Refer to "FUEL INJECTION SYSTEM" in chapter 7.
1	Starter motor lead	1	Disconnect.
2	Starter motor	1	For installation, reverse the removal procedure.

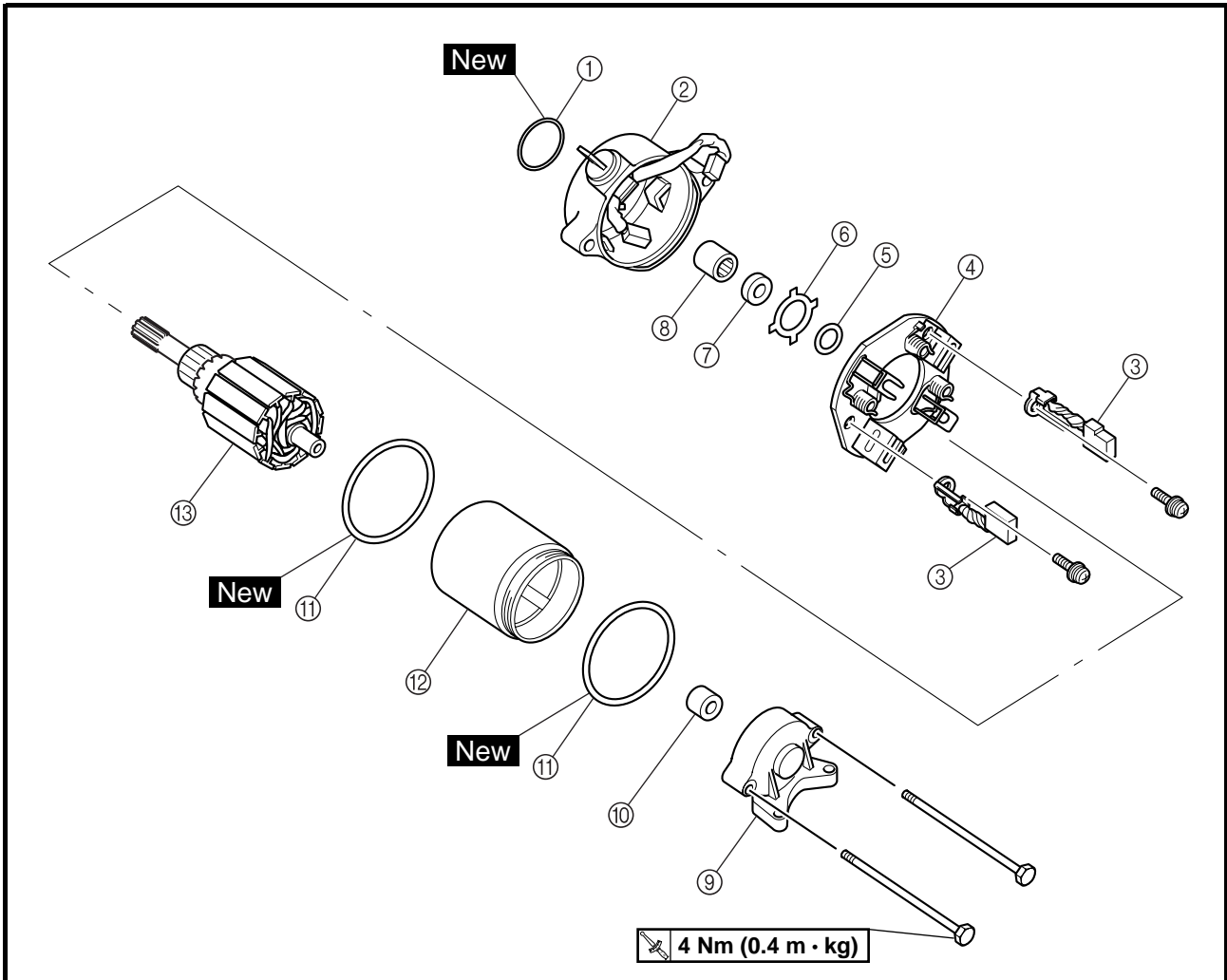
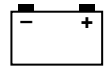

Order	Job/Part	Q'ty	Remarks
	Disassembly the starter motor		Remove the parts in the order listed.
①	O-ring	1	
②	Starter motor front cover	1	
③	Brush	2	
④	Brush seat	1	
⑤	Washer	1	
⑥	Lock washer	1	
⑦	Oil seal	1	
⑧	Bearing	1	
⑨	Starter motor rear cover	1	
⑩	Collar	1	

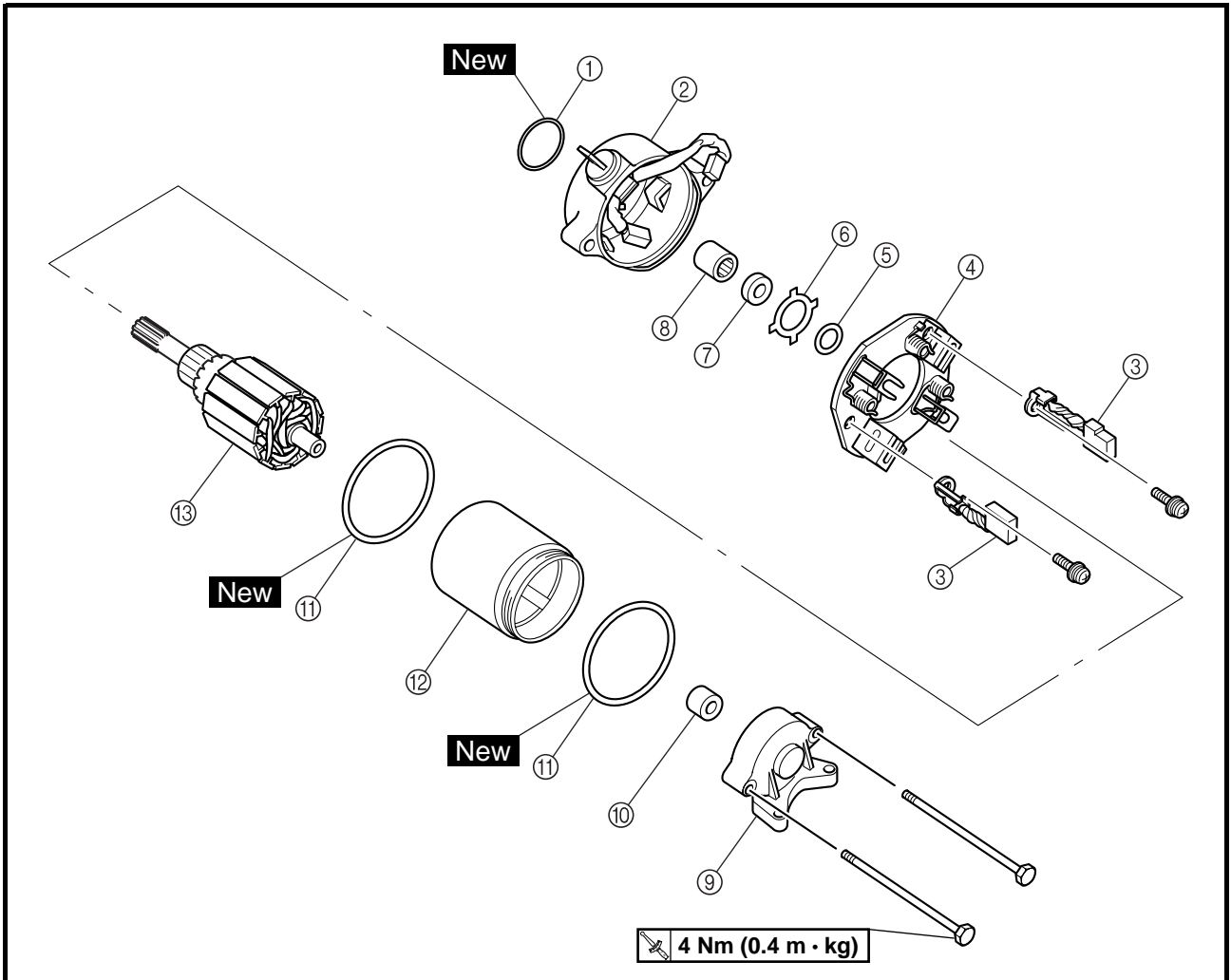
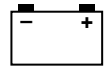

Order	Job/Part	Q'ty	Remarks
⑪	O-ring	1	For assembly, reverse the disassembly procedure.
⑫	Starter motor yoke	1	
⑬	Armature assembly	1	

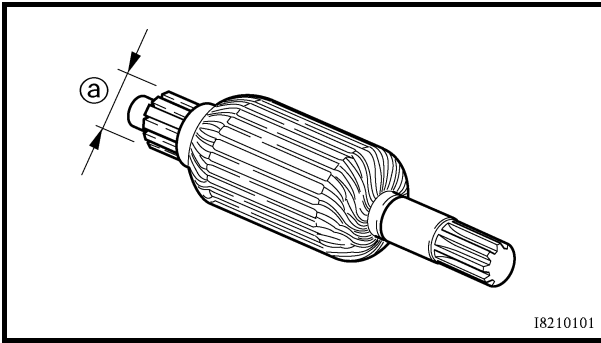
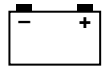

EAS00770

CHECKING THE STARTER MOTOR

1. Check:
 - commutator
Dirt → Clean with 600 grit sandpaper.
2. Measure:
 - commutator diameter @
Out of specification → Replace the starter motor.



Commutator wear limit
23.5 mm

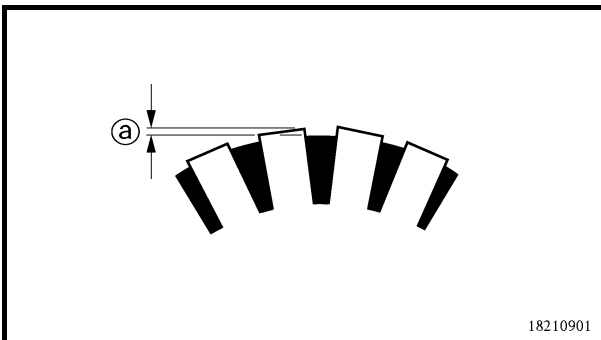

3. Measure:
 - mica undercut @
Out of specification → Scrape the mica to the proper measurement with a hacksaw blade that has been grounded to fit the commutator.



Mica undercut
1.5 mm

NOTE:

The mica of the commutator must be undercut to ensure proper operation of the commutator.

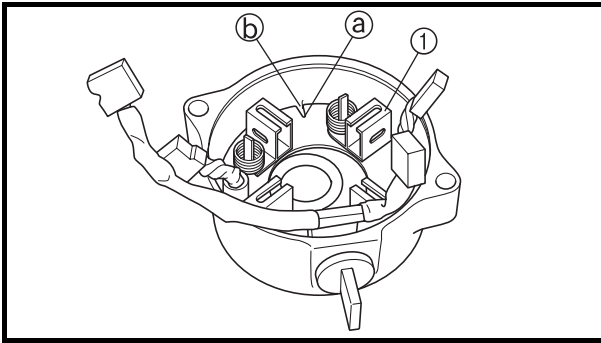
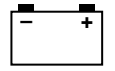

EAS00772

ASSEMBLING THE STARTER MOTOR

1. Install:

- brush seat ①

NOTE:

Align the slot ① on the brush seat with the tab ② in the starter motor front cover.

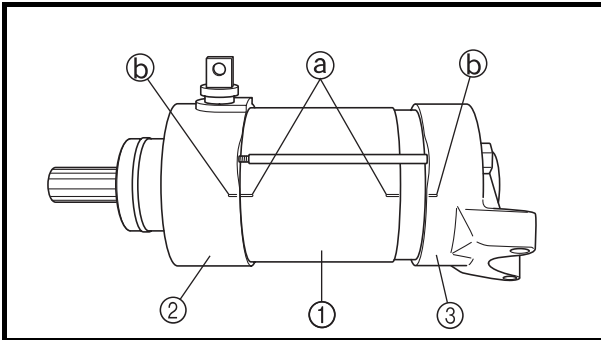

2. Install:

- starter motor yoke ①
- starter motor front cover ②
- starter motor rear cover ③

NOTE:

Align the match marks ① on the starter motor yoke with the match marks ② on the front and rear covers.

3. Install:

- O-rings **New**
- bolts

4 Nm (0.4 m · kg)

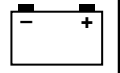

EAS00773

CHARGING SYSTEM CIRCUIT DIAGRAM

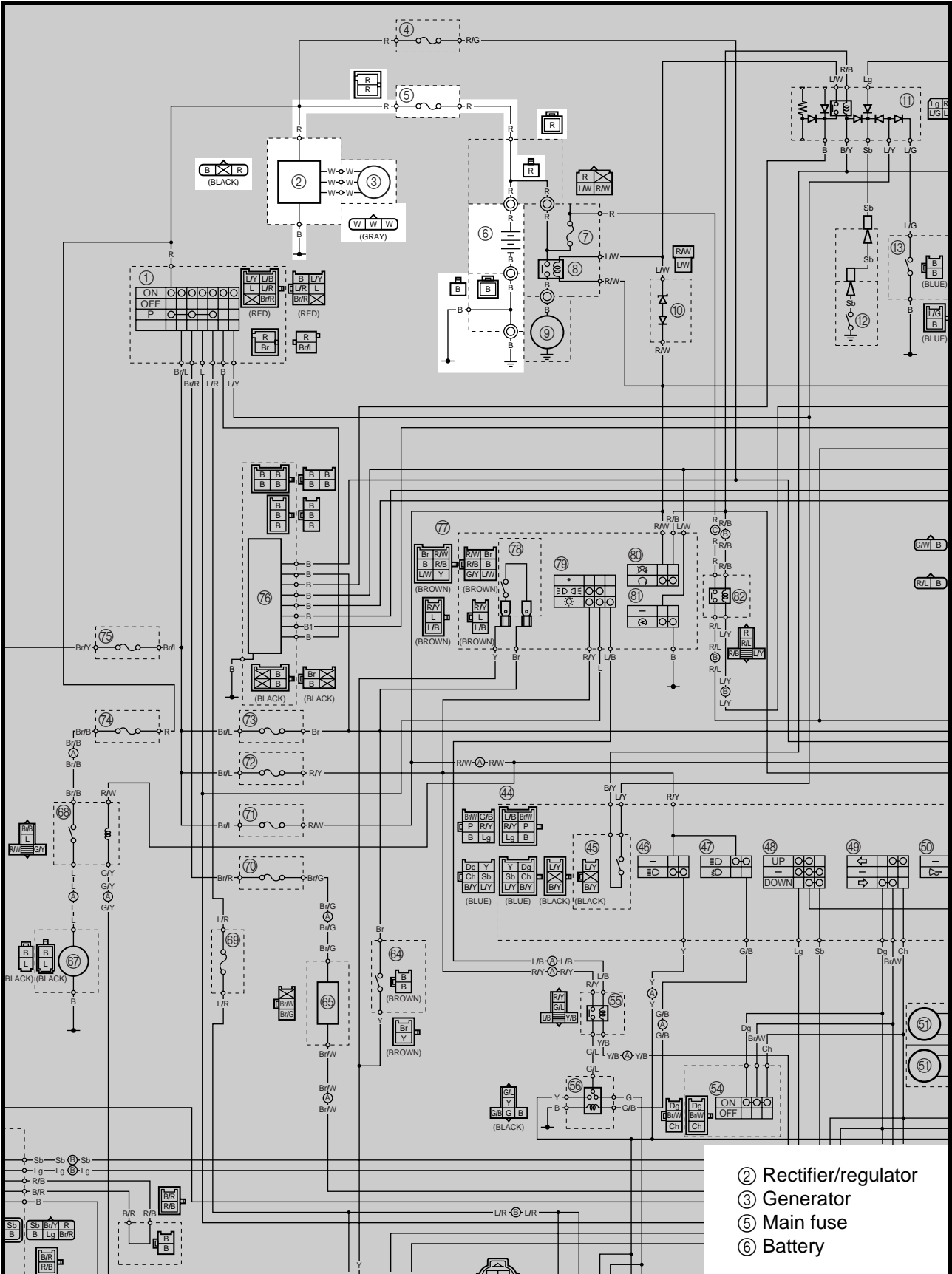

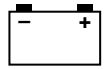

EAS00774

TROUBLESHOOTING

The battery is not being charged.

Check:

1. main fuse
2. battery
3. charging voltage
4. stator assembly resistance
5. wiring connections
(of the entire charging system)

NOTE:

- Before troubleshooting, remove the following part(s):
 - 1) front cowling assembly
 - 2) fuel tank
 - 3) air filter case
- Troubleshoot with the following special tool(s).

	Engine tachometer 90890-06760 Pocket tester 90890-03112
--	--

EAS00738

1. Main fuse <ul style="list-style-type: none"> • Check the main fuse for continuity. Refer to "CHECKING THE FUSES" in chapter 3. • Is the main fuse OK?
--

↓ YES

↓ NO

Replace the fuse.

EAS00739

2. Battery	
<ul style="list-style-type: none"> • Check the condition of the battery. Refer to "CHECKING AND CHARGING THE BATTERY" in chapter 3. 	
	Minimum open-circuit voltage 12.8 V or more at 20 °C
<ul style="list-style-type: none"> • Is the battery OK? 	

↓ YES

↓ NO

- Clean the battery terminals.
- Recharge or replace the battery.

EAS00775

3. Charging voltage	
<ul style="list-style-type: none"> • Connect the engine tachometer to the spark plug lead of cylinder #1. • Connect the pocket tester (DC 20 V) to the battery as shown. 	
Tester positive probe → positive battery terminal Tester negative probe → negative battery terminal	
<ul style="list-style-type: none"> • Start the engine and let it run at approximately 5,000 r/min. • Measure the charging voltage. 	
	Charging voltage 14 V at 5,000 r/min

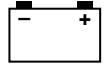

NOTE:

Make sure the battery is fully charged.

- Is the charging voltage within specification?



The charging circuit is OK.

EAS00776

4. Stator assembly resistance

- Remove the generator cover.
- Connect the pocket tester ($\Omega \times 1$) to the stator assembly coupler as shown.

Tester positive probe → white ①

Tester negative probe → white ②

Tester positive probe → white ①

Tester negative probe → white ③

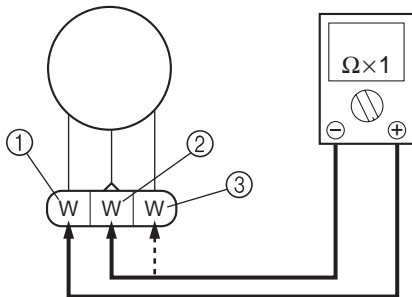

- Measure the stator coil resistances.



Stator coil resistance
0.15 ~ 0.23 Ω at 20 °C

- Is the stator coil OK?



Replace the stator assembly.

EAS00779

5. Wiring

- Check the wiring connections of the entire charging system. Refer to "CIRCUIT DIAGRAM".
- Is the charging system's wiring properly connected and without defects?



Replace the rectifier/regulator.

Properly connect or repair the charging system's wiring.

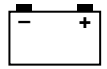

EAS00780

LIGHTING SYSTEM CIRCUIT DIAGRAM

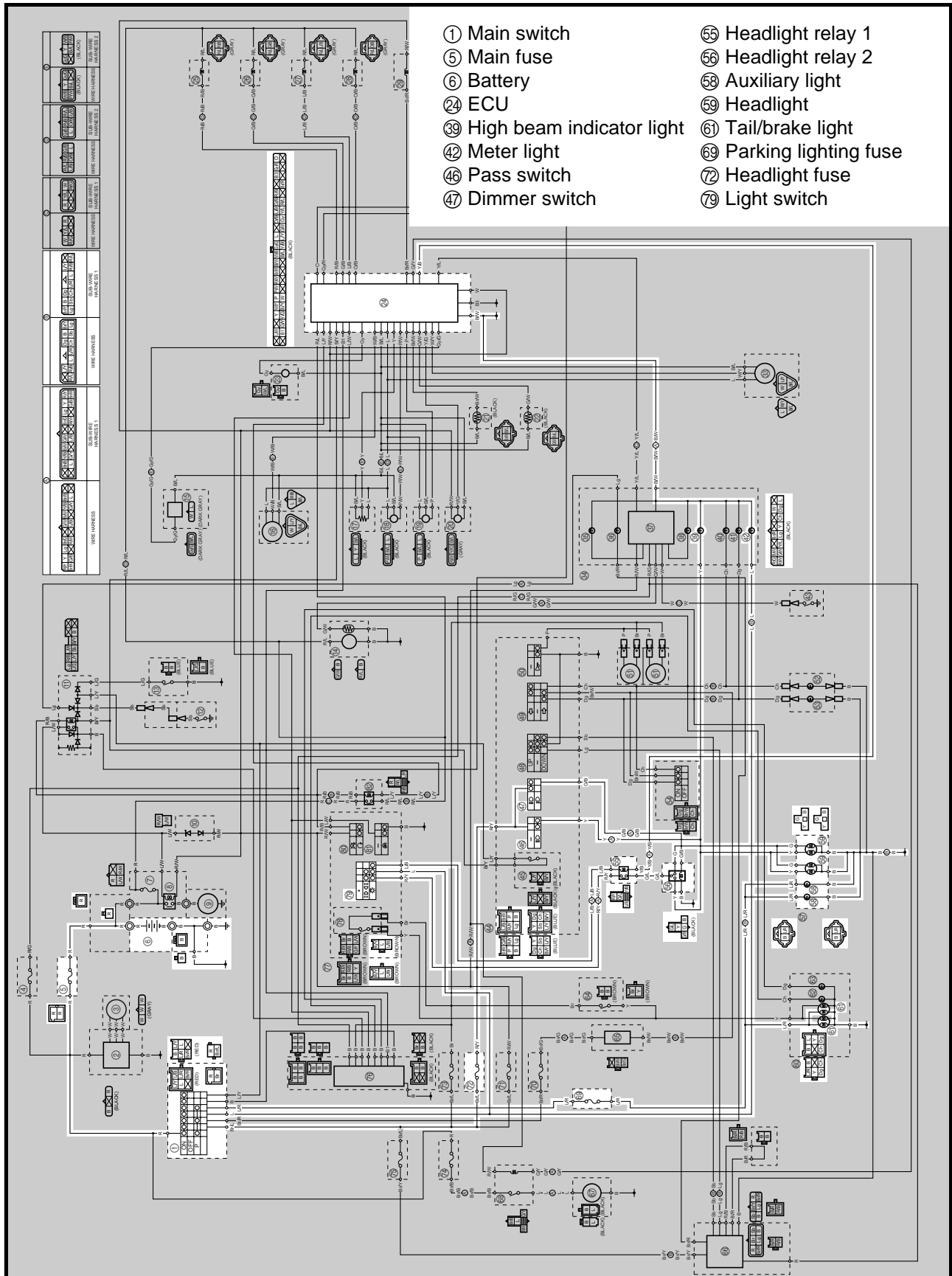

- | | |
|------------------------------|--------------------------|
| ① Main switch | ⑤⑤ Headlight relay 1 |
| ⑤ Main fuse | ⑤⑥ Headlight relay 2 |
| ⑥ Battery | ⑤⑧ Auxiliary light |
| ②④ ECU | ⑤⑨ Headlight |
| ③⑨ High beam indicator light | ⑥① Tail/brake light |
| ④② Meter light | ⑥⑨ Parking lighting fuse |
| ④⑥ Pass switch | ⑦② Headlight fuse |
| ④⑦ Dimmer switch | ⑦⑨ Light switch |

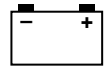

EAS00781

TROUBLESHOOTING

Any of the following fail to light: headlight, high beam indicator light, taillight, auxiliary light or meter light.

Check:

1. main, parking lighting and headlight fuses
2. battery
3. main switch
4. light switch
5. dimmer switch
6. pass switch
7. headlight relay 1
8. headlight relay 2
9. wiring connections
(of the entire lighting system)

NOTE:

- Before troubleshooting, remove the following part(s):
 - 1) fuel tank
 - 2) front cowling assembly
 - 3) rear cover
- Troubleshoot with the following special tool(s).

	Pocket tester 90890-03112
--	--

EAS00738

1. Main, parking lighting and headlight fuses • Check the main, parking lighting and headlight fuses for continuity. Refer to "CHECKING THE FUSES" in chapter 3. • Are the main, parking lighting and headlight fuses OK?
--



Replace the fuse(s).

EAS00739

2. Battery • Check the condition of the battery. Refer to "CHECKING AND CHARGING THE BATTERY" in chapter 3.		
<table border="1"> <tr> <td style="text-align: center;"></td> <td> Minimum open-circuit voltage 12.8 V or more at 20 °C </td> </tr> </table>		Minimum open-circuit voltage 12.8 V or more at 20 °C
	Minimum open-circuit voltage 12.8 V or more at 20 °C	
• Is the battery OK?		



• Clean the battery terminals.
• Recharge or replace the battery.

EAS00749

3. Main switch • Check the main switch for continuity. Refer to "CHECKING THE SWITCHES". • Is the main switch OK?
--



Replace the main switch.

EAS00783

4. Light switch • Check the light switch for continuity. Refer to "CHECKING THE SWITCHES". • Is the light switch OK?



The light switch is faulty. Replace the right handlebar switch.

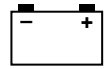

EAS00784

5. Dimmer switch

- Check the dimmer switch for continuity. Refer to "CHECKING THE SWITCHES".
- Is the dimmer switch OK?



The dimmer switch is faulty. Replace the left handlebar switch.

EAS00786

6. Pass switch

- Check the pass switch for continuity. Refer to "CHECKING THE SWITCHES".
- Is the pass switch OK?



The pass switch is faulty. Replace the left handlebar switch.

7. Headlight relay 1

- Disconnect the headlight relay 1 from the wire harness.
- Connect the pocket tester ($\Omega \times 1$) and battery (12 V) to the headlight relay 1 terminal as shown.
- Check the headlight relay 1 for continuity.

Battery positive terminal → blue/black ①
Battery negative terminal → yellow/black ②

Tester positive probe → red/yellow ③
Tester negative probe → green/blue ④

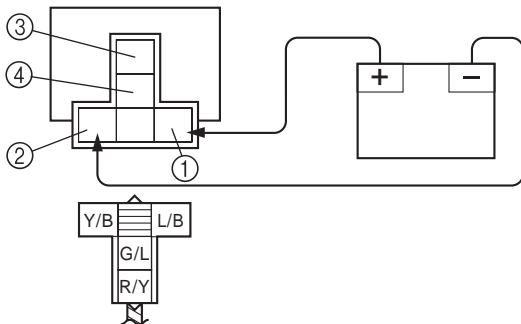

- Does the headlight relay 1 have continuity between red/yellow and green/blue?



Replace the headlight relay 1.

8. Headlight relay 2

- Disconnect the headlight relay 2 from the wire harness.
- Connect the pocket tester ($\Omega \times 1$) and battery (12 V) to the headlight relay 2 terminal as shown.
- Check the headlight relay 2 of continuity.

Tester positive probe → green/blue ①
Tester negative probe → green ②

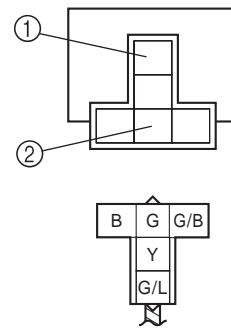

Battery positive terminal → green/black ③
Battery negative terminal → black ④

Tester positive probe → green/blue ⑤
Tester negative probe → yellow ⑥

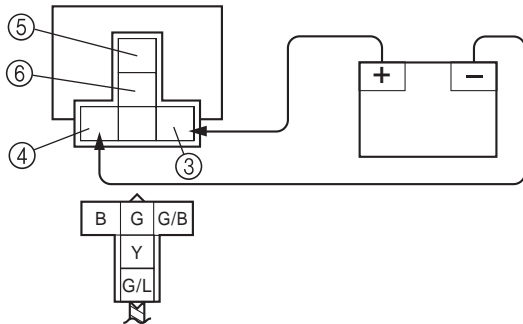

• Does the headlight relay 2 have continuity between green/blue and green or yellow?

↓ YES

↓ NO

Replace the headlight relay 2.

EAS00787

9. Wiring

- Check the entire lighting system's wiring. Refer to "CIRCUIT DIAGRAM".
- Is the lighting system's wiring properly connected and without defects?

↓ YES

↓ NO

Check the condition of each of the lighting system's circuits. Refer to "CHECKING THE LIGHTING SYSTEM".

Properly connect or repair the lighting system's wiring.

EAS00788

CHECKING THE LIGHTING SYSTEM

1. The headlight and the high beam indicator light fail to come on.

1. Headlight bulb and socket

- Check the headlight bulb and socket for continuity.
- Are the headlight bulb and socket OK?

↓ YES

↓ NO

Replace the headlight bulb, socket or both.

2. Voltage

- Connect the pocket tester (DC 20 V) to the headlight coupler and meter light assembly as shown.

A When the dimmer switch is set to "☹☹☹"

B When the dimmer switch is set to "☹☹☹"

Headlight coupler

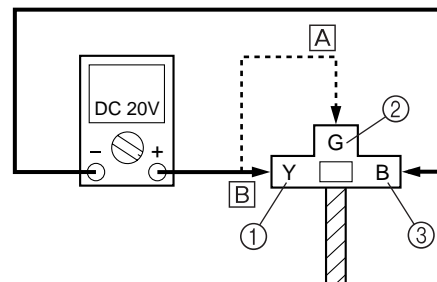

Headlight

Tester positive probe → yellow ① or green ②
Tester negative probe → black ③

High beam indicator light
Tester positive probe → yellow ④
Tester negative probe → black/white ⑤

Meter assembly coupler

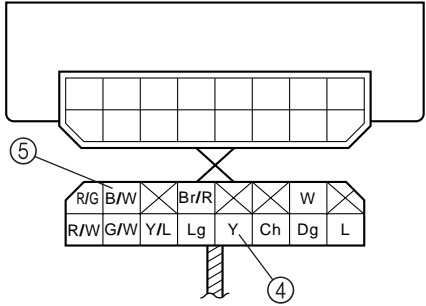

- Set the main switch to “ON”.
- Set the light switch to “☀”.
- Set the dimmer switch to “≡D” or “≡D”.
- Measure the voltage (12 V) of green on the headlight coupler.
- Is the voltage within specification?

YES NO

This circuit is OK.

The wiring circuit from the main switch to the headlight coupler is faulty and must be repaired.

EAS00789

2. The meter light fails to come on.

1. Meter light bulb and socket

- Check the meter light bulb and socket for continuity.
- Are the meter light bulb and socket OK?

YES NO

Replace the meter light bulb, socket or both.

2. Voltage

- Connect the pocket tester (DC 20 V) to the meter assembly coupler as shown.

Tester positive probe → blue ①
Tester negative probe → black/white ②

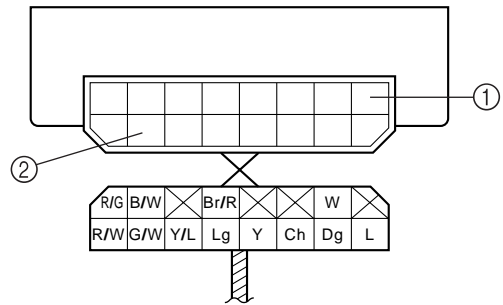

- Set the main switch to “ON”.
- Set the light switch to “≡D” or “☀”.
- Measure the voltage (12 V) of blue ① on the meter assembly coupler.
- Is the voltage within specification?

YES NO

This circuit is OK.

The wiring circuit from the main switch to the meter assembly coupler is faulty and must be repaired.

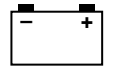

EAS00790

3. The tail/brake light fails to come on.

1. Tail/brake light bulb and socket
- Check the tail/brake light bulb and socket for continuity.
 - Are the tail/brake light bulb and socket OK?

↓ YES

↓ NO

Replace the tail/brake light bulb, socket or both.

2. Voltage
- Connect the pocket tester (DC 20 V) to the tail/brake light coupler (wire harness side) as shown.

Tester positive probe → blue/red ①
 Tester negative probe → black ②

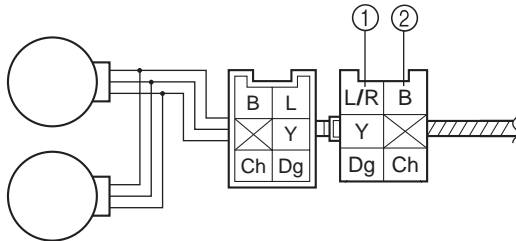

- Set the main switch to "ON".
- Set the light switch to "☰☱" or "☼".
- Measure the voltage (12 V) of blue/red ① on the tail/brake light coupler (wire harness side).
- Is the voltage within specification?

↓ YES

↓ NO

This circuit is OK.

wiring circuit from the main switch to the tail/brake light coupler is faulty and must be repaired.

EAS00791

4. The auxiliary light fails to come on.

1. Auxiliary light bulb and socket
- Check the auxiliary light bulb and socket for continuity.
 - Are the auxiliary light bulb and socket OK?

↓ YES

↓ NO

Replace the auxiliary light bulb, socket or both.

2. Voltage
- Connect the pocket tester (DC 20 V) to the auxiliary light couplers (wire harness side) as shown.

Tester positive probe → blue/red ①
 Tester negative probe → black ②

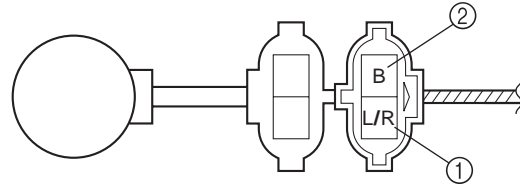

- Set the main switch to "ON".
- Set the light switch to "☰☱" or "☼".
- Measure the voltage (12 V) of blue/red ① on the auxiliary light couplers (wire harness side).
- Is the voltage within specification?

↓ YES

↓ NO

This circuit is OK.

The wiring circuit from the main switch to the auxiliary light couplers is faulty and must be repaired.

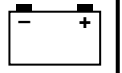

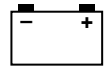

EAS00793

SIGNALING SYSTEM CIRCUIT DIAGRAM

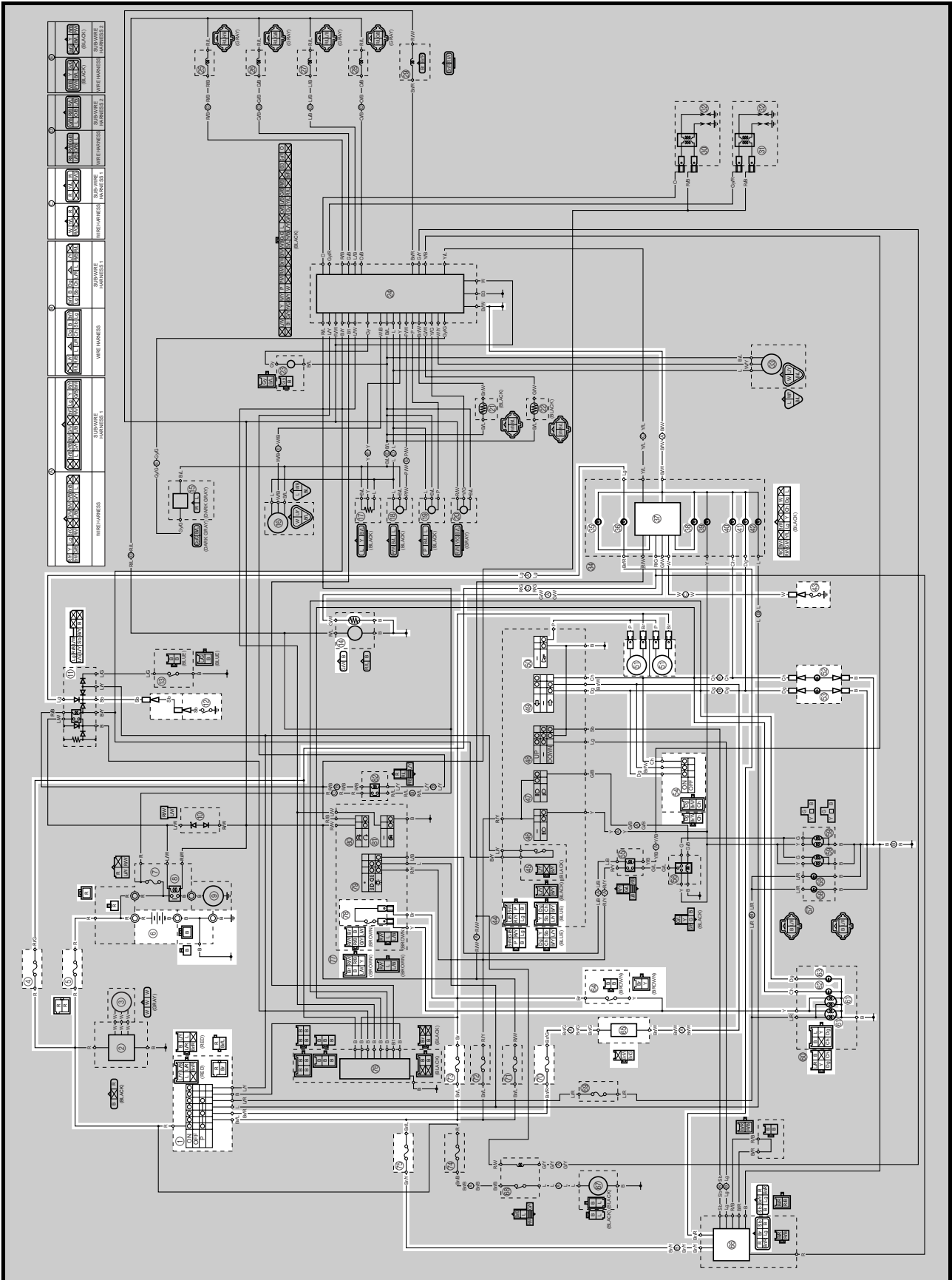

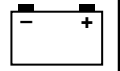

- ① Main switch
- ④ Backup fuse (odometer, clock and windshield)
- ⑤ Main fuse
- ⑥ Battery
- ⑪ Starting circuit cut-off relay
- ⑫ Neutral switch
- ⑭ Fuel pump
- ⑮ Oil level warning light
- ⑯ Neutral indicator light
- ⑰ Multi-function meter
- ⑱ Engine trouble warning light
- ⑲ Left turn signal indicator light
- ⑳ Right turn signal indicator light
- ㉓ Oil level switch
- ㉔ Turn signal switch
- ㉕ Horn switch
- ㉖ Horn
- ㉗ Front turn signal light (left)
- ㉘ Front turn signal light (right)
- ㉙ Hazard switch
- ㉚ Tail/brake light
- ㉛ Rear turn signal light (left)
- ㉜ Rear turn signal light (right)
- ㉝ Rear brake light switch
- ㉞ Turn signal relay
- ㉟ Windshield drive unit
- ㊱ Hazard lighting fuse
- ㊲ Signaling system fuse
- ㊳ Windshield motor fuse
- ㊴ Front brake light switch

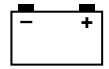

EAS00794

TROUBLESHOOTING

- Any of the following fail to light: flasher light, brake light or an indicator light.
- The horn fails to sound.

Check:

1. main, signaling system, hazard lighting, windshield motor and backup fuses
2. battery
3. main switch
4. wiring connections (of the entire signaling system)

NOTE:

- Before troubleshooting, remove the following part(s):
 - 1) fuel tank
 - 2) front cowling assembly
 - 3) air filter case
- Troubleshoot with the following special tool(s).



Pocket tester
90890-03112

EAS00738

1. Main, signaling system, hazard lighting, windshield motor and backup fuses
 - Check the main, signaling system, hazard lighting, windshield motor and backup fuses for continuity. Refer to "CHECKING THE FUSES" in chapter 3.
 - Are the main, signaling system, hazard lighting, windshield motor and backup fuses OK?

↓ YES

↓ NO

Replace the fuse(s).

EAS00739

2. Battery

- Check the condition of the battery. Refer to "CHECKING AND CHARGING THE BATTERY" in chapter 3.



Minimum open-circuit voltage
12.8 V or more at 20°C

- Is the battery OK?

↓ YES

↓ NO

- Clean the battery terminals.
- Recharge or replace the battery.

EAS00749

3. Main switch

- Check the main switch for continuity. Refer to "CHECKING THE SWITCHES".
- Is the main switch OK?

↓ YES

↓ NO

Replace the main switch.

EAS00795

4. Wiring

- Check the entire signal system's wiring. Refer to "CIRCUIT DIAGRAM".
- Is the signaling system's wiring properly connected and without defects?

↓ YES

↓ NO

Check the condition of each of the signaling system's circuits. Refer to "CHECKING THE SIGNALING SYSTEM".

Properly connect or repair the signaling system's wiring.

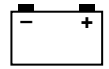

EAS00796

CHECKING THE SIGNALING SYSTEM

1. The horn fails to sound.

1. Horn switch

- Check the horn switch for continuity. Refer to "CHECKING THE SWITCHES".
- Is the horn switch OK?



Replace the left handlebar switch.

2. Voltage

- Connect the pocket tester (DC 20 V) to the horn connector at the horn terminal as shown.

Tester positive probe → brown ①
 Tester negative probe → ground

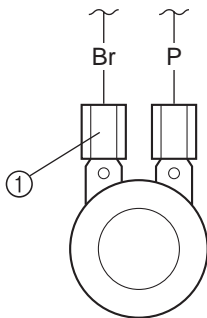

- Set the main switch to "ON".
- Measure the voltage (12 V) of black/white at the horn terminal.
- Is the voltage within specification?



The wiring circuit from the main switch to the horn connector is faulty and must be repaired.

3. Horn

- Disconnect the black connector at the horn terminal.
- Connect a jumper lead ① to the horn terminal and ground the jumper lead.
- Set the main switch to "ON".
- Does the horn sound?

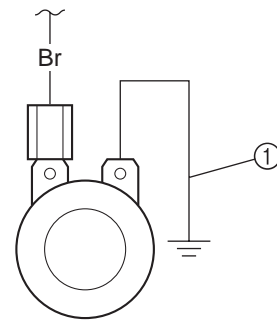

Replace the horn.

The horn is OK.

EAS00797

2. The tail/brake light fails to come on.

1. Tail/brake light bulb and socket

- Check the tail/brake light bulb and socket for continuity.
- Are the tail/brake light bulb and socket OK?



Replace the tail/brake light bulb, socket or both.

2. Brake light switches

- Check the brake light switches for continuity. Refer to "CHECKING THE SWITCHES".
- Is the brake light switch OK?



Replace the brake light switch.

3. Voltage

- Connect the pocket tester (DC 20 V) to the tail light assembly coupler (wire harness side) as shown.

Tester positive probe → yellow ①
 Tester negative probe → black ②

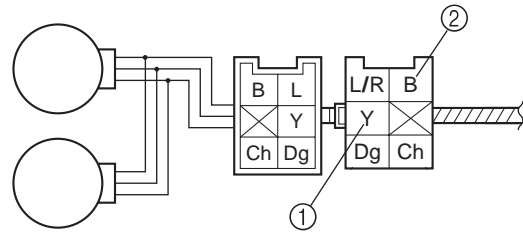

- Set the main switch to "ON".
- Pull in the brake lever or push down on the brake pedal.
- Measure the voltage (12 V) of yellow ① on the tail light assembly coupler (wire harness side).
- Is the voltage within specification?



This circuit is OK.

The wiring circuit from the main switch to the tail light assembly coupler is faulty and must be repaired.

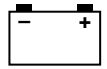

EAS00799

3. The turn signal light, turn signal indicator light or both fail to blink.

1. Turn signal indicator light bulb and socket

- Check the turn signal light bulb and socket for continuity.
- Are the turn signal light bulb and socket OK?



Replace the turn signal light bulb, socket or both.

2. Turn signal switch

- Check the turn signal switch for continuity. Refer to "CHECKING THE SWITCHES".
- Is the turn signal switch OK?



Replace the left handlebar switch.

3. Voltage

- Connect the pocket tester (DC 20 V) to the turn signal relay coupler as shown.

Tester positive probe → brown/green ①

Tester negative probe → ground

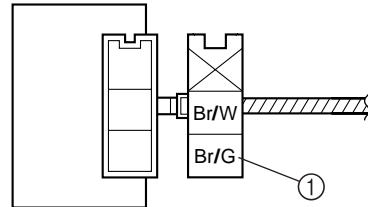

- Set the main switch to "ON".
- Measure the voltage (12 V) on brown/green ① at the turn signal relay coupler.
- Is the voltage within specification?



The wiring circuit from the main switch to the turn signal relay coupler is faulty and must be repaired.

4. Voltage

- Connect the pocket tester (DC 20 V) to the turn signal relay coupler as shown.

Tester positive probe → brown/white ①

Tester negative probe → ground

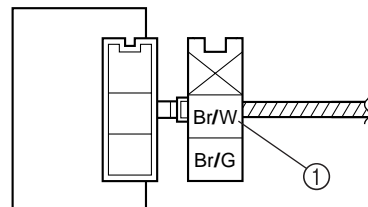

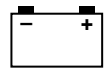

- Set the main switch to “ON”.
- Set the turn signal switch to “←” or “→”.
- Measure the voltage (12 V) on brown/white ① at the turn signal relay coupler.
- Is the voltage within specification?

YES

NO

The turn signal relay is faulty and must be replaced.

- Set the main switch to “ON”.
- Set the turn signal switch to “←” or “→”.
- Measure the voltage (12 V) of the chocolate ① or dark green ②.
- Is the voltage within specification?

YES

NO

This circuit is OK.

The wiring circuit from the turn signal switch to the front turn signal light connectors (wire harness side), tail light assembly coupler (wire harness side) or meter assembly coupler is faulty and must be repaired.

5. Voltage

- Connect the pocket tester (DC 20 V) to the front turn signal light connectors (wire harness side), tail light assembly coupler (wire harness side) or meter assembly coupler as shown.

- [A] Front turn signal light
- [B] Rear turn signal light
- [C] Turn signal indicator light

Left turn signal light

Tester positive probe → chocolate ①

Tester negative probe → ground

Right turn signal light

Tester positive probe → dark green ②

Tester negative probe → ground

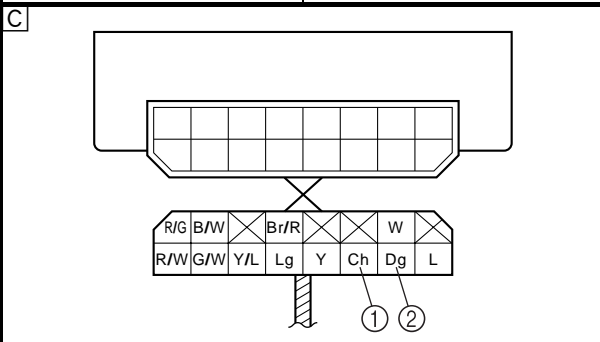
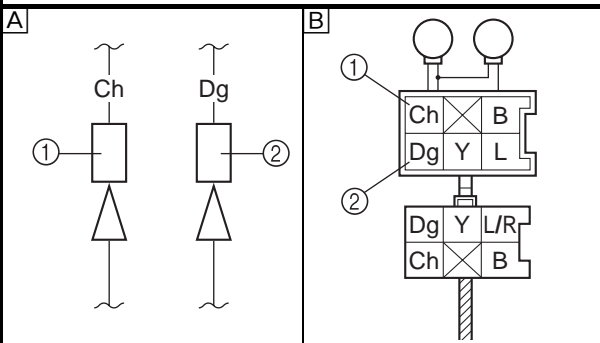

EAS00800

4. The neutral indicator light fails to come on.

1. Neutral indicator light bulb and socket

- Check the neutral indicator light bulb and socket for continuity.
- Are the neutral indicator light bulb and socket OK?

YES

NO

Replace the neutral indicator light bulb, socket or both.

2. Neutral switch

- Check the neutral switch for continuity. Refer to “CHECKING THE SWITCHES”.
- Is the neutral switch OK?

YES

NO

Replace the neutral switch.

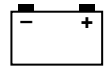

EAS00753

3. Starting circuit cut-off relay

- Disconnect the starting circuit cut-off relay from the wire harness.
- Connect the pocket tester ($\Omega \times 1$) to the starting circuit cut-off relay terminals as shown.
- Check the starting circuit cut-off relay for continuity.

Tester positive probe → sky blue ①
Tester negative probe → light green ②

Continuity

Tester positive probe → light green ②
Tester negative probe → sky blue ①

No continuity

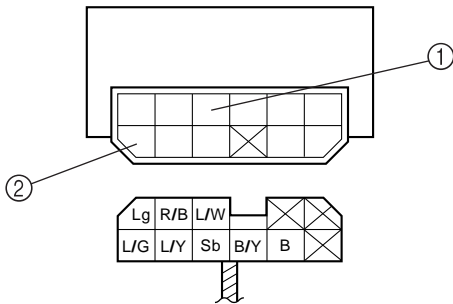

NOTE: _____
 When you switch the positive and negative tester probes, the readings in the above chart will be reversed.

• Are the tester readings correct?



Replace the starting circuit cut-off relay.

4. Voltage

• Connect the pocket tester (DC 20 V) to the meter assembly coupler as shown.

Tester positive probe → brown/red ①

Tester negative probe → light green ②

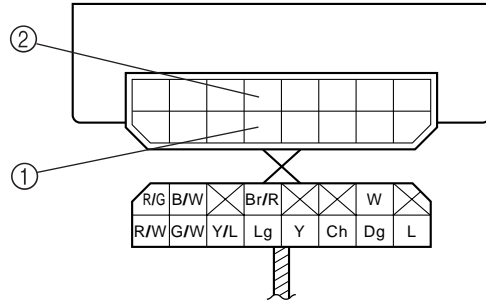

• Set the main switch to "ON".
 • Measure the voltage (12 V).
 • Is the voltage within specification?



Replace the windshield drive unit.

The wiring circuit from the main switch to the meter assembly coupler is faulty and must be repaired.

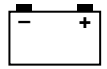

EAS00802

5. The oil level warning light fails to come on.

1. Oil level warning light bulb and socket

- Check the oil level warning light bulb and socket for continuity.
- Are the oil level warning light bulb and socket OK?

↓ YES

↓ NO

Replace the oil level warning light bulb, socket or both.

2. Oil level switch

- Drain the engine oil and remove the engine oil level switch from the oil pan.
- Check the engine oil level switch for continuity. Refer to "CHECKING THE SWITCHES".
- Is the engine oil level switch OK?

↓ YES

↓ NO

Replace the engine oil level switch.

3. Voltage

- Connect the pocket tester (DC 20 V) to the meter assembly coupler as shown.

Tester positive probe → white ①
 Tester negative probe → black/white ②

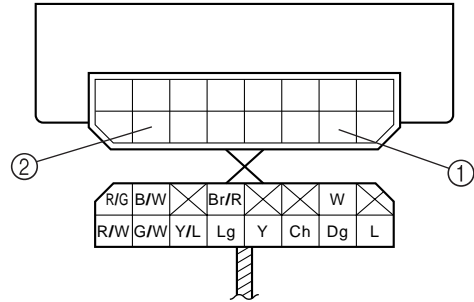

- Set the main switch to "ON".
- Measure the voltage (5 V) of white ① and black/white ② at the meter assembly coupler.
- Is the voltage within specification?

↓ YES

↓ NO

This circuit is OK.

The wiring circuit from the main switch to the meter assembly coupler is faulty and must be repaired.

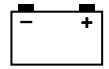

EAS00804

6. The fuel level gauge fails to operate.

1. Fuel sender

- Drain the fuel from the fuel tank and remove the fuel pump from the fuel tank.
- Connect the pocket tester ($\Omega \times 10$) to the fuel sender terminals as shown.

Tester positive probe → green/white ①
Tester negative probe → black ②

- Measure the fuel sender resistances.

NOTE: Measure the resistances when the float arm is in contact with the full position and empty position of the stopper.

Fuel sender resistance
 Full position of the float
 19 ~ 21 Ω at 20 °C
 Empty position of the float
 139 ~ 141 Ω at 20 °C

- Is the fuel sender OK?

↓ YES

↓ NO

Replace the fuel pump.

2. Voltage

- Connect the pocket tester (DC 20 V) to the meter assembly coupler as shown.

Tester positive probe → green/white ①
Tester negative probe → black/white ②

- Set the main switch to "ON".
- Measure the voltage (12 V) of green/white ① and black/white ② at the meter assembly coupler.
- Is the voltage within specification?

↓ YES

↓ NO

The wiring circuit from the main switch to the meter assembly coupler is faulty and must be repaired.

Replace the meter assembly.

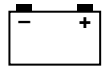

EAS00807

COOLING SYSTEM CIRCUIT DIAGRAM

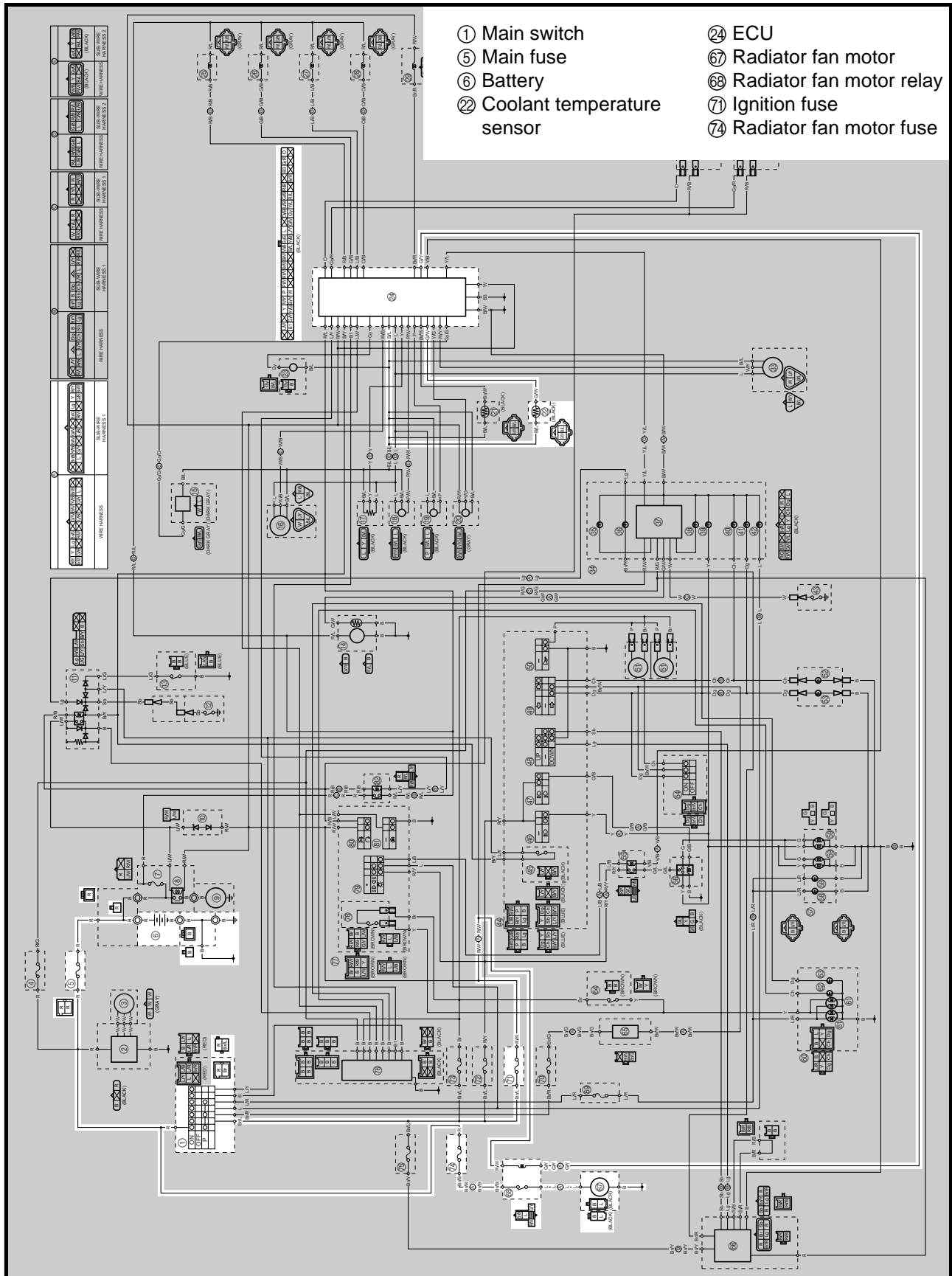

- ① Main switch
- ⑤ Main fuse
- ⑥ Battery
- ② Coolant temperature sensor
- ②④ ECU
- ⑧⑦ Radiator fan motor
- ⑧⑧ Radiator fan motor relay
- ⑦① Ignition fuse
- ⑦④ Radiator fan motor fuse

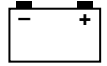

EAS00808

TROUBLESHOOTING

- The radiator fan motor fails to turn.
- The coolant temperature gauge needle fails to move when the engine is warm.

Check:

1. main, ignition, and radiator fan motor fuses
2. battery
3. main switch
4. radiator fan motor
5. radiator fan motor relay
6. coolant temperature sensor
7. wiring connections
(the entire cooling system)

NOTE:

- Before troubleshooting, remove the following part(s):
 - 1) fuel tank and T-bar
 - 2) front cowling assembly
- Troubleshoot with the following special tool(s).



Pocket tester
90890-03112

EAS00738

1. Main, ignition, and radiator fan motor fuses
 - Check the main, ignition, and radiator fan motor fuses for continuity. Refer to "CHECKING THE FUSES" in chapter 3.
 - Are the main, ignition, and radiator fan motor fuses OK?

↓ YES

↓ NO

Replace the fuse(s).

EAS00739

2. Battery

- Check the condition of the battery. Refer to "CHECKING AND CHARGING THE BATTERY" in chapter 3.



Minimum open-circuit voltage
12.8 V or more at 20 °C

- Is the battery OK?

↓ YES

↓ NO

- Clean the battery terminals.
- Recharge or replace the battery.

EAS00749

3. Main switch

- Check the main switch for continuity. Refer to "CHECKING THE SWITCHES".
- Is the main switch OK?

↓ YES

↓ NO

Replace the main switch.

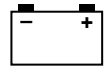

EAS00809

4. Radiator fan motor (test 1)

- Disconnect the radiator fan motor coupler from the wire harness.
- Connect the battery (12 V) as shown.

Battery positive lead → blue ①

Battery negative lead → black ②

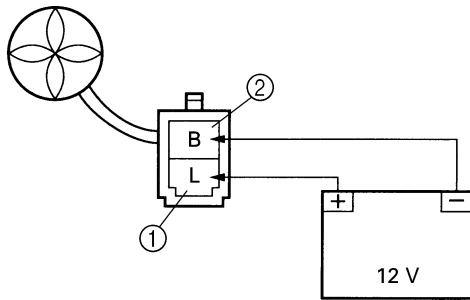

- Does the radiator fan motor turn?



The radiator fan motor is faulty and must be replaced.

EAS00810

5. Radiator fan motor (test 2)

- Disconnect the coolant temperature sensor coupler from the coolant temperature sensor.
- Connect the green/white ① and black/blue ② terminals with a jumper lead ③ shown.

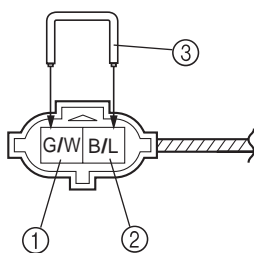

- Does the radiator fan motor turn?



The radiator fan motor is faulty and must be replaced.

6. Radiator fan motor relay

- Disconnect the radiator fan motor relay from the wire harness.
- Connect the pocket tester ($\Omega \times 1$) and battery (12 V) to the radiator fan motor terminal as shown.
- Check the radiator fan motor of continuity.

Battery positive terminal → red/white ①

Battery negative terminal → green/yellow ②

Tester positive probe → brown/black ③

Tester negative probe → blue ④

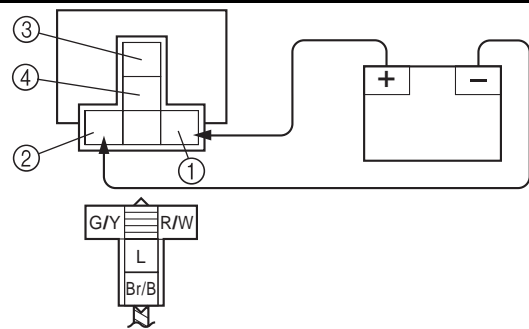

- Does the radiator fan motor have continuity between brown/black and blue?



Replace the radiator fan motor.

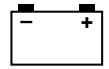

EAS00811

7. Coolant temperature sensor

- Remove the coolant temperature sensor from the thermostat assembly inlet pipe.
- Connect the pocket tester ($\Omega \times 1$) to the coolant temperature sensor ① as shown.
- Immerse the coolant temperature sensor in a container filled with coolant ②.

NOTE:

Make sure that the coolant temperature sensor terminals do not get wet.

- Place a thermometer ③ in the coolant.
- Slowly heat the coolant, then let it cool down to the specified temperature.
- Check the coolant temperature sensor for continuity at the temperatures indicated below.

Test step	Coolant temperature	Continuity
	Coolant temperature sensor	
1	Less than 105 °C	NO
2	More than 105 °C	YES
3	More than 100 °C	YES
4	Less than 100 °C	NO

Test steps 1 & 2: Heating phase

Test steps 3 & 4: Cooling phase

⚠ WARNING

- Handle the coolant temperature sensor with special care.
- Never subject the coolant temperature sensor to strong shocks. If the coolant temperature sensor is dropped, replace it.



Coolant temperature sensor
20 Nm (2.0 m · kg)
Three bond sealock®10

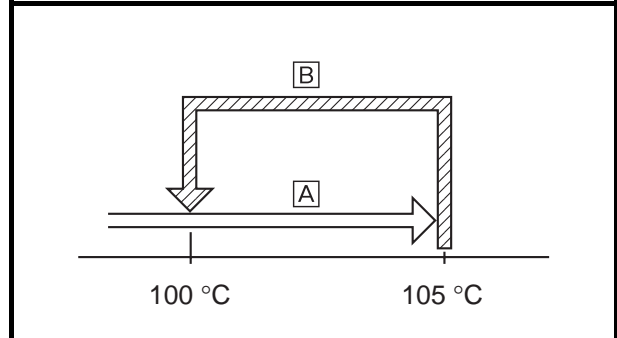
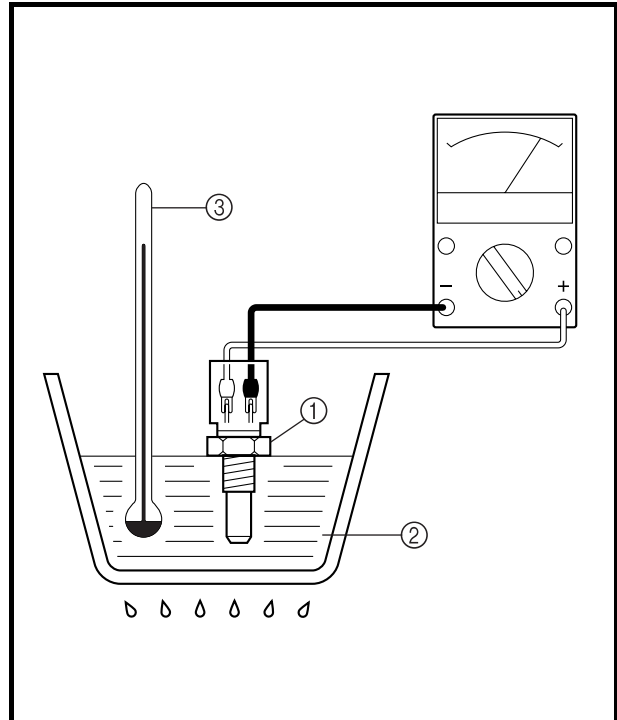

Ⓐ The coolant temperature sensor circuit is open and the radiator fan is off.

Ⓑ The coolant temperature sensor circuit is closed and the radiator fan is on.

- Does the coolant temperature sensor operate properly as described above?



Replace the coolant temperature sensor.

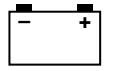

EAS00813

8. Wiring

- Check the entire cooling system's wiring. Refer to "CIRCUIT DIAGRAM".
- Is the cooling system's wiring properly connected and without defects?



Replace the ECU.

Properly connect or repair the cooling system's wiring.

FUEL INJECTION SYSTEM
CIRCUIT DIAGRAM

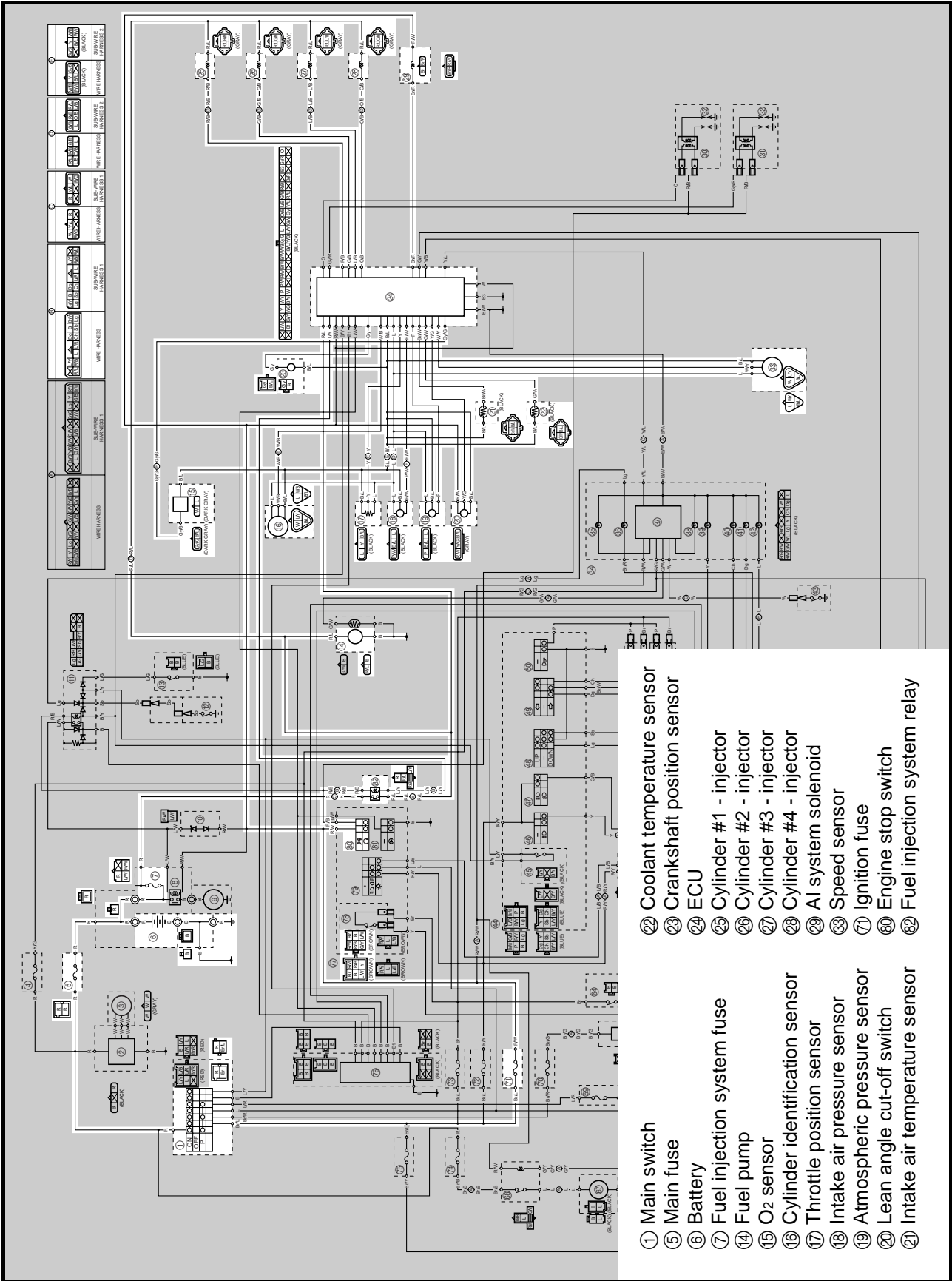

- ① Main switch
- ⑤ Main fuse
- ⑥ Battery
- ⑦ Fuel injection system fuse
- ⑭ Fuel pump
- ⑮ O₂ sensor
- ⑯ Cylinder identification sensor
- ⑰ Throttle position sensor
- ⑱ Intake air pressure sensor
- ⑲ Atmospheric pressure sensor
- ⑳ Lean angle cut-off switch
- ㉑ Intake air temperature sensor
- ㉒ Coolant temperature sensor
- ㉓ Crankshaft position sensor
- ㉔ ECU
- ㉕ Cylinder #1 - injector
- ㉖ Cylinder #2 - injector
- ㉗ Cylinder #3 - injector
- ㉘ Cylinder #4 - injector
- ㉙ AI system solenoid
- ㉚ Speed sensor
- ㉛ Ignition fuse
- ㉜ Engine stop switch
- ㉝ Fuel injection system relay

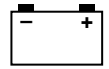

EAS00816

TROUBLESHOOTING

If the fuel injection system fails to operate.

Check:

1. main, fuel injection system and ignition fuses
2. battery
3. main switch
4. engine stop switch
5. fuel injection system relay
6. fuel pump resistance
7. crankshaft position sensor
8. cylinder indication sensor
9. speed sensor
10. coolant temperature sensor
11. intake air temperature sensor
12. intake air pressure sensor
13. atmospheric pressure sensor
14. AI system solenoid
15. wiring connections
(the entire fuel system)

NOTE:

- Before troubleshooting, remove the following part(s):
 - 1) fuel tank
 - 2) front cowling assembly
 - 3) air filter case
- Troubleshoot with the following special tool(s).



**Pocket tester
90890-03112**

EAS00738

1. Main, fuel injection system and ignition fuses
 - Check the main, fuel injection system and ignition fuses for continuity. Refer to "CHECKING THE FUSES" in chapter 3.
 - Are the main, fuel injection system and ignition fuses OK?

↓ YES

↓ NO

Replace the fuse(s).

EAS00739

2. Battery

- Check the condition of the battery. Refer to "CHECKING AND CHARGING THE BATTERY" in chapter 3.



**Minimum open-circuit voltage
12.8 V or more at 20°C**

- Is the battery OK?

↓ YES

↓ NO

- Clean the battery terminals.
- Recharge or replace the battery.

EAS00749

3. Main switch

- Check the main switch for continuity. Refer to "CHECKING THE SWITCHES".
- Is the main switch OK?

↓ YES

↓ NO

Replace the main switch.

EAS00750

4. Engine stop switch

- Check the engine stop switch for continuity. Refer to "CHECKING THE SWITCHES".
- Is the engine stop switch OK?

↓ YES

↓ NO

Replace the right handlebar switch.

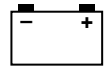

EAS00759

5. Fuel injection system relay

- Disconnect the fuel injection system relay from the wire harness.
- Connect the pocket tester ($\Omega \times 1$) and battery (12 V) to the fuel injection system relay terminals as shown.

Battery positive terminal → red/black ①

Battery negative terminal → blue/yellow ②

Tester positive probe → red ③

Tester negative probe → red/blue ④

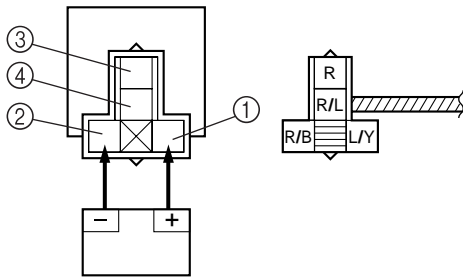

- Does the fuel injection system relay have continuity between blue/white and black?

↓ YES

↓ NO

Replace the fuel injection system relay.

EAS00817

6. Fuel pump resistance

- Disconnect the fuel pump coupler from the fuel pump.
- Connect the pocket tester ($\Omega \times 1$) to the fuel pump coupler as shown.

Tester positive probe → red/blue ①

Tester negative probe → black ②

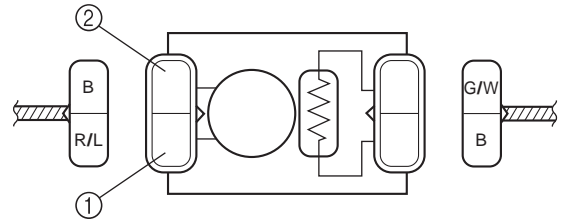

- Measure the fuel pump resistance.



Fuel pump resistance
0.2 ~ 3.0 Ω at 20°C

- Is the fuel pump OK?

↓ YES

↓ NO

Replace the fuel pump.

EAS00748

7. Crankshaft position sensor resistance

- Disconnect the crankshaft position sensor coupler from the wire harness.
- Connect the pocket tester ($\Omega \times 100$) to the crankshaft position sensor coupler as shown.

Tester positive probe → gray ①

Tester negative probe → black ②

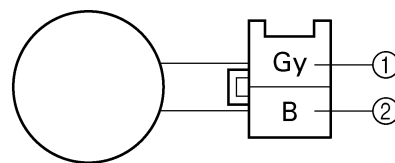

- Measure the crankshaft position sensor resistance.

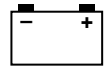

Crankshaft position sensor resistance
 420 ~ 569 Ω at 20 °C
 (between gray and black)

- Is the crankshaft position sensor OK?



Replace the crankshaft position sensor.

8. Cylinder identification sensor output voltage

- Connect the pocket tester (DC 20 V) to the cylinder identification sensor coupler terminal as shown.

Tester positive probe → white ①

Tester negative probe → black/blue ②

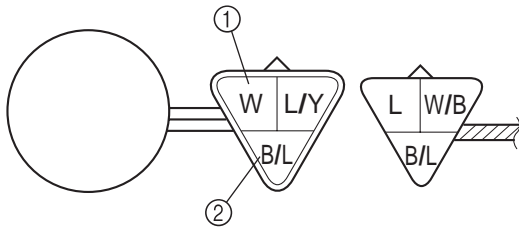

- Set the main switch to "ON".
- Measure the cylinder identification sensor output voltage.



Cylinder identification sensor output voltage
 When sensor is on
 DC 4.8 V or more
 When sensor is off
 DC 0.6 V or less

- Is the cylinder identification sensor OK?



Replace the cylinder identification sensor.

9. Speed sensor output voltage

- Measure the speed sensor output voltage.
- Connect the pocket tester (DC 20 V) to the speed sensor coupler terminal as shown.

Tester positive probe → white ①

Tester negative probe → black/blue ②

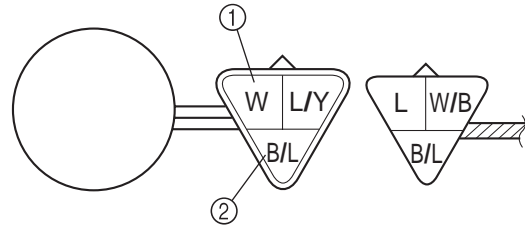

- Measure the speed sensor output voltage.

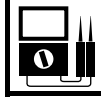

Speed sensor output voltage
 When sensor is on
 DC 4.8 V or more
 When sensor is off
 DC 0.6 V or less

- Is the speed sensor OK?



Replace the speed sensor.

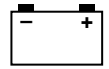

EAS00811

10. Coolant temperature sensor

- Remove the coolant temperature sensor from the thermostat assembly inlet pipe.
- Connect the pocket tester ($\Omega \times 1$) to the coolant temperature sensor ① as shown.
- Immerse the coolant temperature sensor in a container filled with coolant ②.

NOTE:

Make sure that the coolant temperature sensor terminals do not get wet.

- Place a thermometer ③ in the coolant.
- Slowly heat the coolant, then let it cool down to the specified temperature.
- Check the coolant temperature sensor for continuity at the temperatures indicated below.

Test step	Coolant temperature	Continuity
	Coolant temperature sensor	
1	Less than 105 °C	NO
2	More than 105 °C	YES
3	More than 100 °C	YES
4	Less than 100 °C	NO

Test steps 1 & 2: Heating phase

Test steps 3 & 4: Cooling phase

⚠ WARNING

- Handle the coolant temperature sensor with special care.
- Never subject the coolant temperature sensor to strong shocks. If the coolant temperature sensor is dropped, replace it.



Coolant temperature sensor
20 Nm (2.0 m · kg)
Three bond sealock®10

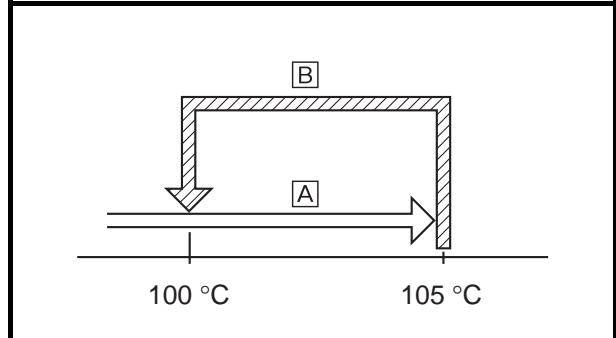
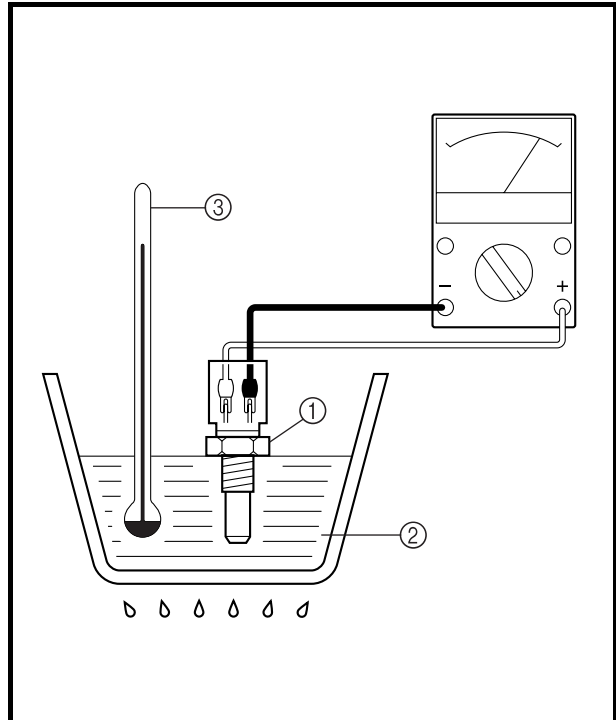

A The coolant temperature sensor circuit is open and the radiator fan is off.

B The coolant temperature sensor circuit is closed and the radiator fan is on.

- Does the coolant temperature sensor operate properly as described above?



Replace the coolant temperature sensor.

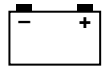

11. Intake air temperature sensor resistance

- Remove the intake air temperature sensor from the air filter case.
- Connect the pocket tester ($\Omega \times 100$) to the intake air temperature sensor terminal as shown.

Tester positive probe → brown/white ①

Tester negative probe → black/blue ②

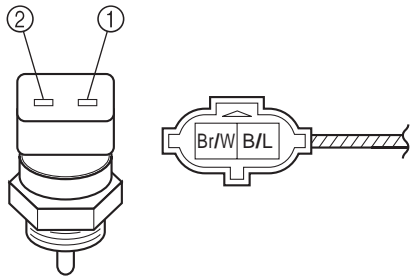

- Measure the intake air temperature sensor resistance.



Intake air temperature sensor resistance
450 ~ 550 Ω at 20 °C

⚠ WARNING

- Handle the intake air temperature sensor with special care.
- Never subject the intake air temperature sensor to strong shocks. If the intake air temperature sensor is dropped, replace it.



Intake air temperature sensor
18 Nm (1.8 m · kg)

- Is the intake air temperature sensor OK?

↓ YES

↓ NO

Replace the intake air temperature sensor.

12. Intake air pressure sensor output voltage

- Connect the pocket tester (DC 20 V) to the intake air intake air pressure sensor coupler terminal as shown.

Tester positive probe → blue ①

Tester negative probe → black/blue ②

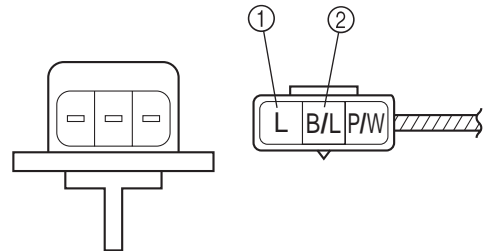

- Set the main switch to "ON".
- Measure the intake air pressure sensor output voltage.



Intake air pressure sensor output voltage
3.75 ~ 4.25 D.C V

- Is the intake air pressure sensor OK?

↓ YES

↓ NO

Replace the intake air pressure sensor.

13. Atmospheric pressure sensor output voltage

- Connect the pocket tester (DC 20 V) to the atmospheric pressure sensor coupler terminal as shown.

Tester positive probe → blue ①
 Tester negative probe → black/blue ②

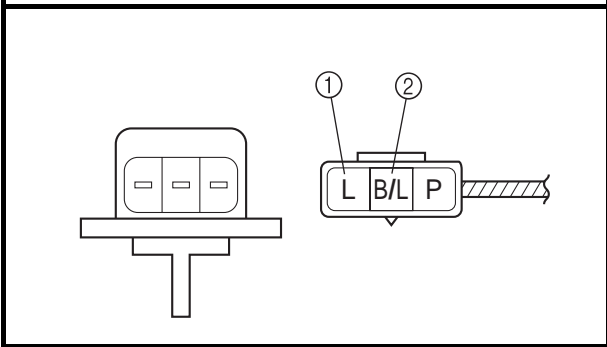

- Set the main switch to "ON".
- Measure the atmospheric pressure sensor output voltage.

 **Atmospheric pressure sensor output voltage**
 3.75 ~ 4.25 DCV

- Is the atmospheric pressure sensor OK?

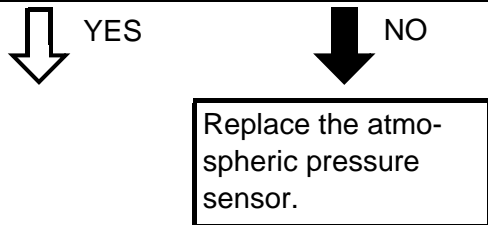

14. AI system solenoid

- Remove the AI system solenoid coupler from the wire harness.
- Connect the pocket tester ($\Omega \times 1$) to the AI system solenoid terminal as shown.

Tester positive probe → brown ①
 Tester negative probe → brown/red ②

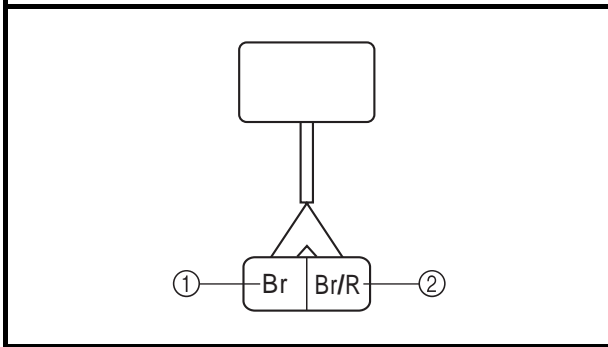

- Measure the AI system solenoid resistance.

 **AI system solenoid resistance**
 19 ~ 25 Ω at 20 °C

- Is the AI system solenoid OK?

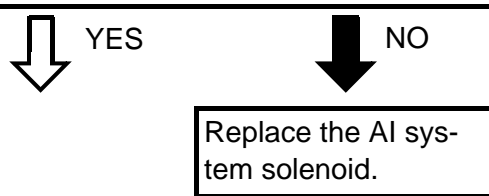

EAS00818
 15. Wiring

- Check the entire fuel injection system's wiring. Refer to "CIRCUIT DIAGRAM".
- Is the fuel injection system's wiring properly connected and without defects?

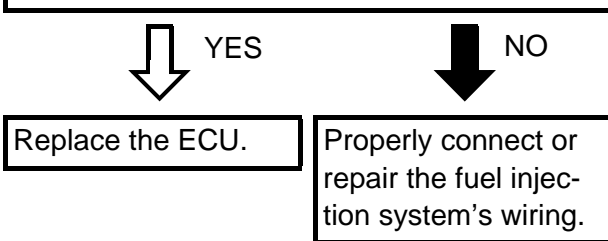

EAS00819

CHECKING THE FUEL PUMP

⚠ WARNING

Gasoline is extremely flammable and under certain circumstances there can be a danger of an explosion or fire. Be extremely careful and note the following points:

- Stop the engine before refueling.
- Do not smoke, and keep away from open flames, sparks, or any other source of fire.
- If you do accidentally spill gasoline, wipe it up immediately with dry rags.
- If gasoline touches the engine when it is hot, a fire may occur. Therefore, make sure the engine is completely cool before performing the following test.

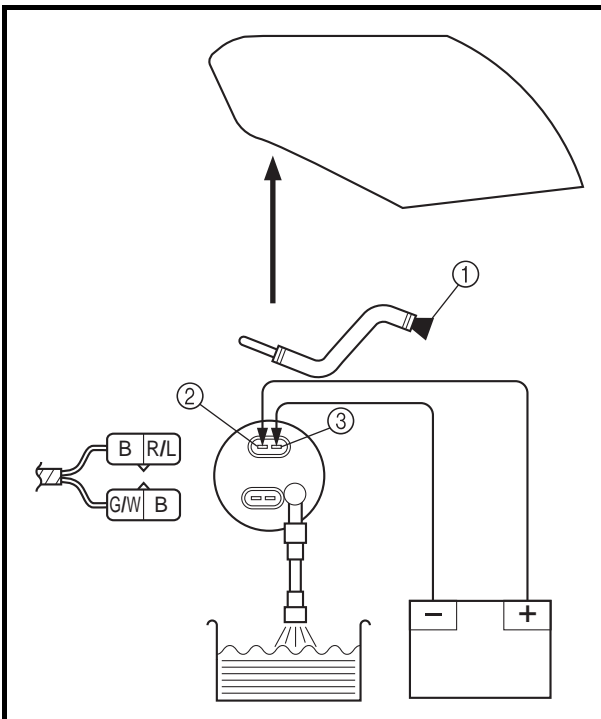

1. Check:
 - fuel pump operation



- a. Insert the plug ① to fuel return hose end.
- b. Fill the fuel tank.
- c. Put the end of the fuel hose into an open container.
- d. Connect the battery (12 V) to the fuel pump terminals as shown.

Battery positive lead → red/blue ②
Battery negative lead → black ③

- e. If fuel flows out of the fuel hose, the fuel pump is OK. If fuel does not flow, replace the fuel pump.



EAS00502

CHECKING AND ADJUSTING THE THROTTLE POSITION SENSOR

NOTE: _____

Before adjusting the throttle position sensor, the engine idling speed should be properly adjusted.

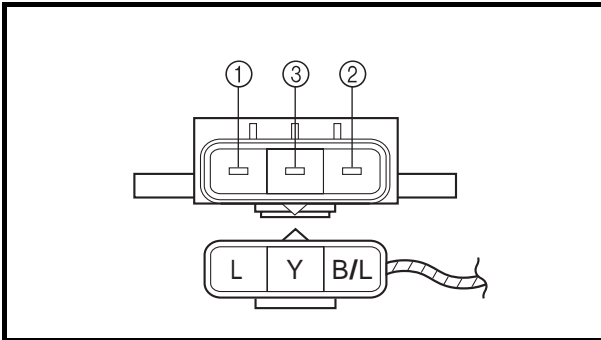

1. Check:
 - throttle position sensor (installed on the throttle body)



- a. Disconnect the throttle position sensor coupler from the throttle position sensor.
- b. Connect the pocket tester ($\Omega \times 1k$) to the throttle position sensor.

Tester positive probe → blue terminal ①
Tester negative tester probe → black/blue terminal ②

- c. Measure the maximum throttle position sensor resistance.
 Out of specification → Replace the throttle position sensor.

Maximum throttle position sensor resistance
 4.0 ~ 6.0 k Ω at 20 °C
 (blue — black/blue)

- d. Connect the pocket tester ($\Omega \times 1k$) to the throttle position sensor.

Tester positive probe → yellow terminal ③
Tester negative probe → black/blue terminal ②

- e. While slowly opening the throttle, check that the throttle position sensor resistance is within the specified range.

NOTE: _____

Check mainly that the resistance changes gradually when turning the throttle, since the readings (from closed to wide-open throttle) may differ slightly from those specified.

Out of specification or the resistance changes abruptly → Go to step 2 below.

 **Throttle position sensor resistance**
 (520 ~ 900 Ω) ~ (4.0 ~ 6.0 kΩ) at 20 °C
 (yellow — black/blue)

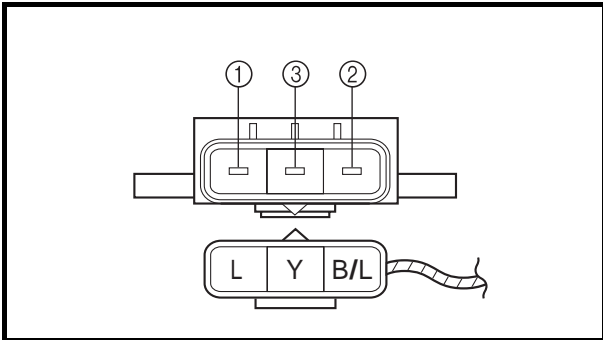

2. Check:
- throttle position sensor (removed from the throttle body)



- Disconnect the throttle position sensor coupler from the throttle position sensor.
- Remove the throttle position sensor from the throttle body.
- Connect the pocket tester ($\Omega \times 1k$) to the throttle position sensor.

Tester positive probe → blue terminal ①
Tester negative probe → black/blue terminal ②

- Measure the maximum throttle position sensor resistance.
 Out of specification → Replace the throttle position sensor.

 **Maximum throttle position sensor resistance**
 4.0 ~ 6.0 kΩ at 20 °C
 (blue — black/blue)

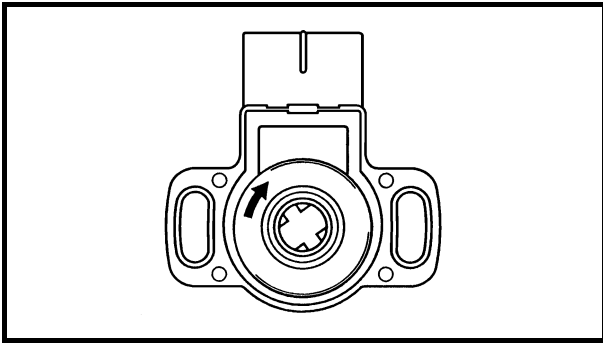

e. Connect the pocket tester ($\Omega \times 1k$) to the throttle position sensor.

Tester positive probe → yellow terminal ③
Tester negative probe → black/blue terminal ②

f. While slowly opening the throttle, check that the throttle position sensor resistance is within the specified range.

The resistance does not change or it changes abruptly → Replace the throttle position sensor.

The slot is worn or broken → Replace the throttle position sensor.

NOTE: _____
 Check mainly that the resistance changes gradually when turning the throttle, since the readings (from closed to wide-open throttle) may differ slightly from those specified.

 **Throttle position sensor resistance**
 0 ~ 5 ± 1.0 k Ω at 20 °C
 (yellow — black/blue)

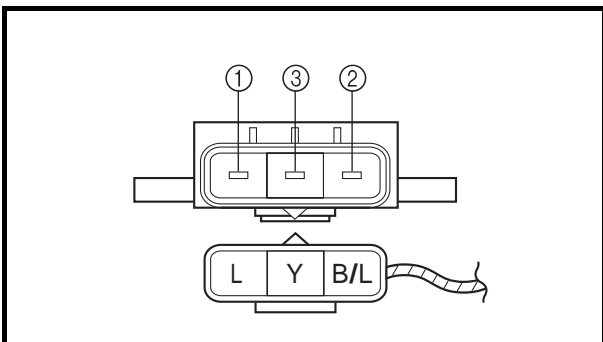

3. Adjust:
 • throttle position sensor angle



a. Disconnect the throttle position sensor coupler from the throttle position sensor.

b. Connect the pocket tester ($\Omega \times 1k$) to the throttle position sensor.

Tester positive probe → blue terminal ①
Tester negative probe → black/blue terminal ②

c. Measure the throttle position sensor maximum resistance.

d. Calculate the throttle position sensor maximum resistance when the throttle is closed.

Throttle position sensor maximum resistance (throttle is fully closed) =
 Maximum resistance × (0.13 ~ 0.15)

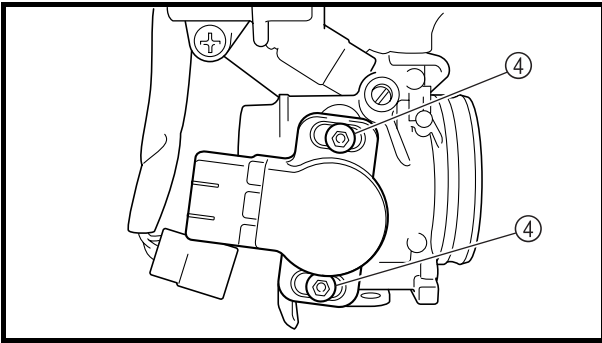
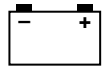

Example:

If the maximum resistance = 5 k Ω , then the throttle position sensor's maximum resistance when the throttle is fully closed should be:

$$5 \text{ k}\Omega \times (0.13 \sim 0.15) = 650 \sim 750 \Omega$$

Lift the throttle body assembly slightly out of the intake manifolds. Loosen the throttle position sensor screws ④.

Connect the pocket tester ($\Omega \times 100$) to the throttle position sensor.

Tester positive probe → yellow terminal ③
Tester negative probe → black/blue terminal ②

e. Adjust the throttle position sensor angle so the measured resistance is within the specified range.

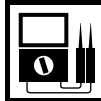

Throttle position sensor resistance
650 ~ 750 Ω
(yellow — black/blue)

After adjusting the throttle position sensor angle, tighten the throttle position sensor screws.



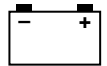

WINDSHIELD DRIVE SYSTEM CIRCUIT DIAGRAM

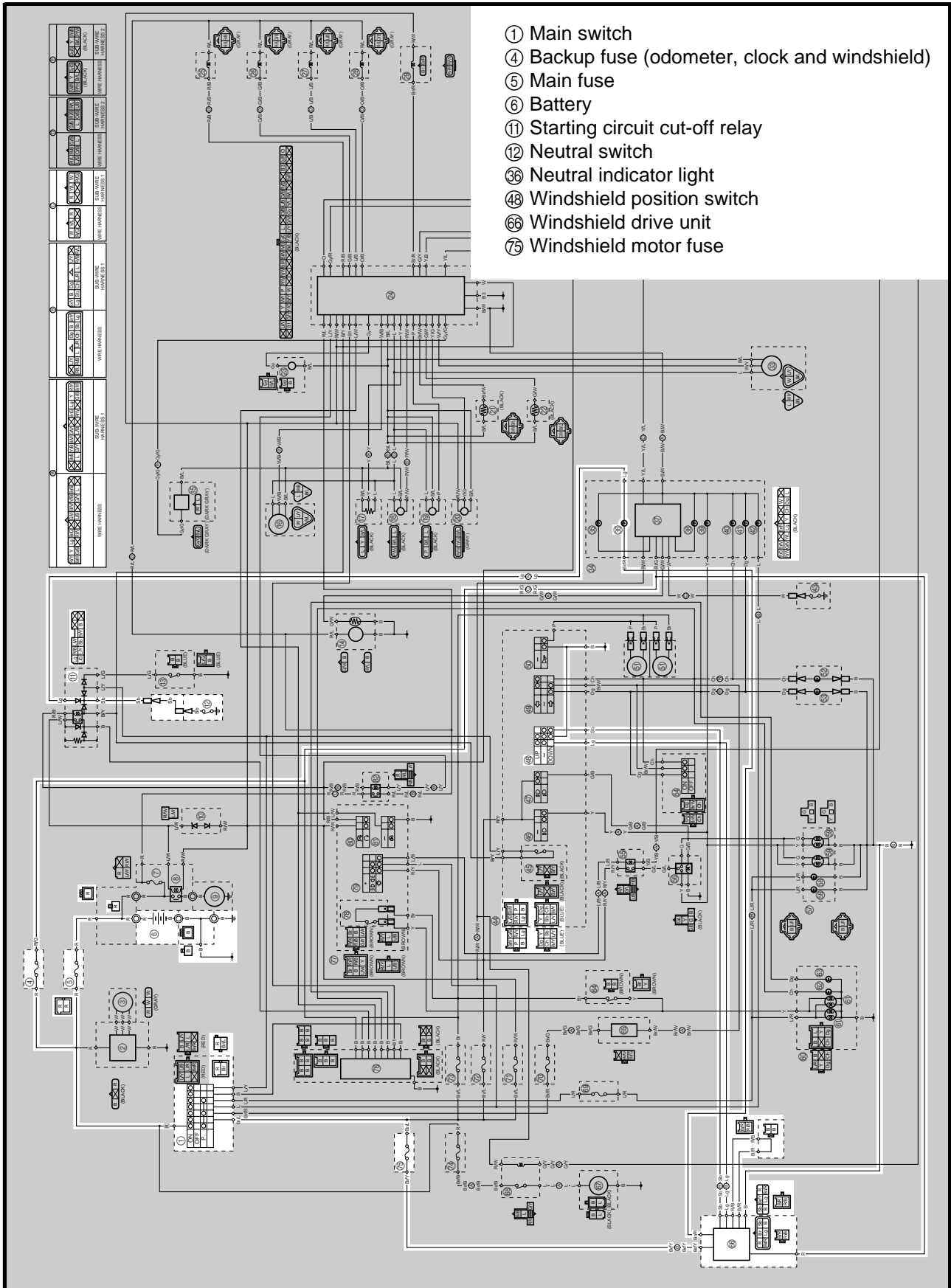

TROUBLESHOOTING

The windshield fails to operate.

Check:

1. main, windshield motor and backup fuses
2. battery
3. main switch
4. windshield position adjusting switch
5. wiring connections
(of the windshield drive system)

NOTE:

- Before troubleshooting, remove the following part(s):
 - 1) fuel tank
 - 2) front cowling assembly
 - 3) air filter case
- Troubleshoot with the following special tool(s).

Pocket tester
90890-03112

EAS00738

1. Main, windshield motor and backup fuses

- Check the main, windshield motor and backup fuses for continuity. Refer to "CHECKING THE FUSES" in chapter 3.
- Are the main, windshield motor and backup fuses OK?



Replace the fuse(s).

EAS00739

2. Battery

- Check the condition of the battery. Refer to "CHECKING AND CHARGING THE BATTERY" in chapter 3.

Minimum open-circuit voltage
12.8 V or more at 20°C

- Is the battery OK?

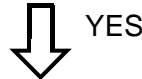

- Clean the battery terminals.
- Recharge or replace the battery.

EAS00749

3. Main switch

- Check the main switch for continuity. Refer to "CHECKING THE SWITCHES".
- Is the main switch OK?



Replace the main switch.

4. Windshield position adjusting switch

- Check the windshield position adjusting switch for continuity. Refer to "CHECKING THE SWITCHES".
- Is the windshield position adjusting switch OK?



Replace the left handlebar switch.

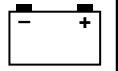

EAS00795

5. Wiring

- Check the entire windshield drive system's wiring.
Refer to "CIRCUIT DIAGRAM".
- Is the windshield drive system's wiring properly connected and without defects?

↓ YES

↓ NO

Replace the windshield drive unit.

Properly connect or repair the windshield drive system's wiring.

NOTE:

- If the windshield is up, it will go down when the gear is in the neutral position and the main switch is set to "OFF".
- The neutral indicator light will blink until the windshield has stopped and is all the way down. If the neutral indicator light does not turn off, replace the windshield drive unit.

?

TRBL

SHTG

9

CHAPTER 9 TROUBLESHOOTING

STARTING PROBLEMS	9-1
ENGINE	9-1
FUEL SYSTEM.....	9-1
ELECTRICAL SYSTEMS	9-2
INCORRECT ENGINE IDLING SPEED	9-2
ENGINE	9-2
FUEL SYSTEM.....	9-2
ELECTRICAL SYSTEMS	9-2
POOR MEDIUM-AND-HIGH-SPEED PERFORMANCE	9-3
ENGINE	9-3
FUEL SYSTEM.....	9-3
FAULTY GEAR SHIFTING	9-3
SHIFTING IS DIFFICULT	9-3
SHIFT PEDAL DOES NOT MOVE	9-3
JUMPS OUT OF GEAR.....	9-3
FAULTY CLUTCH	9-4
CLUTCH SLIPS.....	9-4
CLUTCH DRAGS	9-4
OVERHEATING	9-4
ENGINE	9-4
COOLING SYSTEM	9-4
FUEL SYSTEM.....	9-4
CHASSIS.....	9-4
ELECTRICAL SYSTEMS	9-4
POOR BRAKING PERFORMANCE	9-5
FAULTY FRONT FORK LEGS	9-5
LEAKING OIL	9-5
MALFUNCTION.....	9-5
UNSTABLE HANDLING	9-6

FAULTY LIGHTING OR SIGNALING SYSTEM	9-6
HEADLIGHT DOES NOT LIGHT.....	9-6
HEADLIGHT BULB BURNT OUT.....	9-6
TAIL/BRAKE LIGHT DOES NOT LIGHT.....	9-6
TAIL/BRAKE LIGHT BULB BURNT OUT.....	9-6
TURN SIGNAL DOES NOT LIGHT.....	9-6
TURN SIGNAL BLINKS SLOWLY.....	9-6
TURN SIGNAL REMAINS LIT.....	9-6
TURN SIGNAL BLINKS QUICKLY.....	9-7
HORN DOES NOT SOUND.....	9-7

TROUBLESHOOTING

NOTE:

The following guide for troubleshooting does not cover all the possible causes of trouble. It should be helpful, however, as a guide to basic troubleshooting. Refer to the relative procedure in this manual for checks, adjustments, and replacement of parts.

STARTING PROBLEMS

ENGINE**Cylinder(s) and cylinder head(s)**

- Loose spark plug
- Loose cylinder head
- Damaged cylinder head gasket
- Damaged cylinder gasket
- Worn or damaged cylinder
- Incorrect valve clearance
- Improperly sealed valve
- Incorrect valve-to-valve-seat contact
- Incorrect valve timing
- Faulty valve spring
- Seized valve

Piston(s) and piston ring(s)

- Improperly installed piston ring
- Damaged, worn or fatigued piston ring
- Seized piston ring
- Seized or damaged piston

Air filter

- Improperly installed air filter
- Clogged air filter element

Crankcase and crankshaft

- Improperly assembled crankcase
- Seized crankshaft

FUEL SYSTEM**Fuel tank**

- Empty fuel tank
- Clogged fuel tank drain hose
- Deteriorated or contaminated fuel

Fuel pump

- Faulty fuel pump
- Faulty fuel pump relay

Throttle body(-ies)

- Deteriorated or contaminated fuel
- Sucked-in air

ELECTRICAL SYSTEMS

Battery

- Discharged battery
- Faulty battery

Fuse(s)

- Blown, damaged or incorrect fuse
- Improperly installed fuse

Spark plug(s)

- Incorrect spark plug gap
- Incorrect spark plug heat range
- Fouled spark plug
- Worn or damaged electrode
- Worn or damaged insulator
- Faulty spark plug cap

Ignition coil(s)

- Cracked or broken ignition coil
- Broken or shorted primary or secondary coils
- Faulty spark plug lead

Ignition system

- Faulty ECU
- Faulty crankshaft position sensor
- Broken generator rotor woodruff key

Switches and wiring

- Faulty main switch
- Faulty engine stop switch
- Broken or shorted wiring
- Faulty neutral switch
- Faulty start switch
- Faulty sidestand switch
- Faulty clutch switch
- Improperly grounded circuit
- Loose connections

Starting system

- Faulty starter motor
- Faulty starter relay
- Faulty starting circuit cut-off relay
- Faulty starter clutch

EAS00846

INCORRECT ENGINE IDLING SPEED

ENGINE

Cylinder(s) and cylinder head(s)

- Incorrect valve clearance
- Damaged valve train components

Air filter

- Clogged air filter element

FUEL SYSTEM

Throttle body(-ies)

- Damaged or loose throttle body joint
- Improperly synchronized throttle bodies
- Improperly adjusted engine idling speed (throttle stop screw)
- Improper throttle cable free play
- Flooded throttle body
- Faulty air induction system

ELECTRICAL SYSTEMS

Battery

- Discharged battery
- Faulty battery

Spark plug(s)

- Incorrect spark plug gap
- Incorrect spark plug heat range
- Fouled spark plug
- Worn or damaged electrode
- Worn or damaged insulator
- Faulty spark plug cap

Ignition coil(s)

- Broken or shorted primary or secondary coils
- Faulty spark plug lead
- Cracked or broken ignition coil

Ignition system

- Faulty ignitor unit
- Faulty pickup coil
- Broken generator rotor woodruff key

EAS00848

POOR MEDIUM-AND-HIGH-SPEED PERFORMANCE

Refer to "STARTING PROBLEMS".

ENGINE

Air filter

- Clogged air filter element

FUEL SYSTEM

Fuel pump

- Faulty fuel pump

EAS00850

FAULTY GEAR SHIFTING

SHIFTING IS DIFFICULT

Refer to "CLUTCH DRAGS".

SHIFT PEDAL DOES NOT MOVE

Shift shaft

- Improperly adjusted shift rod
- Bent shift shaft

Shift drum and shift forks

- Foreign object in a shift drum groove
- Seized shift fork
- Bent shift fork guide bar

Transmission

- Seized transmission gear
- Foreign object between transmission gears
- Improperly assembled transmission

JUMPS OUT OF GEAR

Shift shaft

- Incorrect shift pedal position
- Improperly returned stopper lever

Shift forks

- Worn shift fork

Shift drum

- Incorrect axial play
- Worn shift drum groove

Transmission

- Worn gear dog

EAS00852

FAULTY CLUTCH

CLUTCH SLIPS

Clutch

- Improperly assembled clutch
- Improperly assembled clutch master cylinder
- Improperly assembled clutch release cylinder
- Incorrect clutch fluid level
- Damaged clutch hose
- Loose or fatigued clutch spring
- Loose union bolt
- Worn friction plate
- Worn clutch plate
- Damaged clutch release cylinder

Engine oil

- Incorrect oil level
- Incorrect oil viscosity (low)
- Deteriorated oil

EAS00855

OVERHEATING

ENGINE

- Clogged coolant passages
- Heavy carbon buildup in cylinder head(s) and piston(s)

Engine oil

- Incorrect oil level
- Incorrect oil viscosity
- Inferior oil quality

COOLING SYSTEM

Coolant

- Low coolant level

Radiator

- Damaged or leaking radiator
- Faulty radiator cap
- Bent or damaged radiator fin
- Damaged or faulty water pump
- Thermostat stays closed
- Clogged or damaged oil cooler
- Damaged hose
- Improperly connected hose
- Damaged pipe
- Improperly connected pipe

CLUTCH DRAGS

Clutch

- Air in hydraulic clutch system
- Unevenly tensioned clutch springs
- Warped pressure plate
- Bent clutch plate
- Swollen friction plate
- Bent clutch push rod
- Damaged clutch boss
- Burnt primary driven gear bushing
- Damaged clutch release cylinder
- Match marks not aligned

Engine oil

- Incorrect oil level
- Incorrect oil viscosity (high)
- Deteriorated oil

FUEL SYSTEM

Throttle body(-ies)

- Faulty throttle body(-ies)
- Damaged or loose throttle body joint

Air filter

- Clogged air filter element

CHASSIS

Brake(s)

- Dragging brake

ELECTRICAL SYSTEMS

Spark plug(s)

- Incorrect spark plug gap
- Incorrect spark plug heat range

Ignition system

- Faulty ECU

POOR BRAKING PERFORMANCE/ FAULTY FRONT FORK LEGS



EAS00857

POOR BRAKING PERFORMANCE

- Worn brake pad
- Worn brake disc
- Air in hydraulic brake system
- Leaking brake fluid
- Faulty brake caliper seal
- Loose union bolt
- Damaged brake hose
- Oil or grease on the brake disc
- Oil or grease on the brake pad
- Incorrect brake fluid level

EAS00860

FAULTY FRONT FORK LEGS

LEAKING OIL

- Bent, damaged or rusty inner tube
- Cracked or damaged outer tube
- Improperly installed oil seal
- Damaged oil seal lip
- Incorrect oil level (high)
- Loose damper rod assembly bolt
- Damaged damper rod assembly bolt copper washer
- Cracked or damaged cap bolt O-ring
- Loose drain bolt
- Damaged drain bolt gasket

MALFUNCTION

- Bent or damaged inner tube
- Bent or damaged outer tube
- Damaged fork spring
- Worn or damaged outer tube bushing
- Bent or damaged damper rod
- Incorrect oil viscosity
- Incorrect oil level

EAS00863

UNSTABLE HANDLING

Handlebars

- Bent or improperly installed right handlebar
- Bent or improperly installed left handlebar

Steering head components

- Improperly installed upper bracket
- Improperly installed lower bracket (improperly tightened ring nut)
- Bent steering stem
- Damaged ball bearing or bearing race

Front fork leg(s)

- Uneven oil levels (both front fork legs)
- Unevenly tensioned fork spring (both front fork legs)
- Broken fork spring
- Bent or damaged inner tube
- Bent or damaged outer tube

Swingarm

- Worn bearing or bushing
- Bent or damaged swingarm

Rear shock absorber assembly(-ies)

- Faulty rear shock absorber spring
- Leaking oil or gas

Tire(s)

- Uneven tire pressures (front and rear)
- Incorrect tire pressure
- Uneven tire wear

Wheel(s)

- Incorrect wheel balance
- Deformed cast wheel
- Damaged wheel bearing
- Bent or loose wheel axle
- Excessive wheel runout

Frame

- Bent frame
- Damaged steering head pipe
- Improperly installed bearing race

EAS00866

FAULTY LIGHTING OR SIGNALING SYSTEM

HEADLIGHT DOES NOT LIGHT

- Wrong headlight bulb
- Too many electrical accessories
- Hard charging
- Incorrect connection
- Improperly grounded circuit
- Poor contacts (main or light switch)
- Burnt-out headlight bulb
- Faulty headlight relay 1
- Faulty headlight relay 2
- Faulty ECU

HEADLIGHT BULB BURNT OUT

- Wrong headlight bulb
- Faulty battery
- Faulty rectifier/regulator
- Improperly grounded circuit
- Faulty main switch
- Faulty light switch
- Headlight bulb life expired

TAIL/BRAKE LIGHT DOES NOT LIGHT

- Wrong tail/brake light bulb
- Too many electrical accessories
- Incorrect connection
- Burnt-out tail/brake light bulb

TAIL/BRAKE LIGHT BULB BURNT OUT

- Wrong tail/brake light bulb
- Faulty battery
- Incorrectly adjusted rear brake light switch
- Tail/brake light bulb life expired

TURN SIGNAL DOES NOT LIGHT

- Faulty turn signal switch
- Faulty turn signal relay
- Burnt-out turn signal bulb
- Incorrect connection
- Damaged or faulty wire harness
- Improperly grounded circuit
- Faulty battery
- Blown, damaged or incorrect fuse

TURN SIGNAL BLINKS SLOWLY

- Faulty turn signal relay
- Faulty main switch
- Faulty turn signal switch
- Incorrect turn signal bulb

TURN SIGNAL REMAINS LIT

- Faulty turn signal relay
- Burnt-out turn signal bulb

FAULTY LIGHTING OR SIGNALING SYSTEM



TURN SIGNAL BLINKS QUICKLY

- Incorrect turn signal bulb
- Faulty turn signal relay
- Burnt-out turn signal bulb

HORN DOES NOT SOUND

- Improperly adjusted horn
- Damaged or faulty horn
- Faulty main switch
- Faulty horn switch
- Faulty battery
- Blown, damaged or incorrect fuse
- Faulty wire harness

FJR1300 WIRING DIAGRAM (for Europe)

- ① Main switch
- ② Rectifier/regulator
- ③ Generator
- ④ Backup fuse (odometer, clock and windshield)
- ⑤ Main fuse
- ⑥ Battery
- ⑦ Fuel injection system fuse
- ⑧ Starter relay
- ⑨ Starter motor
- ⑩ Diode
- ⑪ Starting circuit cut-off relay
- ⑫ Neutral switch
- ⑬ Sidestand switch
- ⑭ Fuel pump
- ⑮ O₂ sensor
- ⑯ Cylinder identification sensor
- ⑰ Throttle position sensor
- ⑱ Intake air pressure sensor
- ⑲ Atmospheric pressure sensor
- ⑳ Lean angle cut-off switch
- ㉑ Intake air temperature sensor
- ㉒ Coolant temperature sensor
- ㉓ Crankshaft position sensor
- ㉔ ECU
- ㉕ Cylinder #1 - injector
- ㉖ Cylinder #2 - injector
- ㉗ Cylinder #3 - injector
- ㉘ Cylinder #4 - injector
- ㉙ AI system solenoid
- ㉚ Cylinder #1, #4 - ignition coil
- ㉛ Cylinder #2, #3 - ignition coil
- ㉜ Spark plug
- ㉝ Speed sensor
- ㉞ Meter assembly
- ㉟ Oil level warning light
- ㊱ Neutral indicator light
- ㊲ Multi-function meter
- ㊳ Engine trouble warning light
- ㊴ High beam indicator light
- ㊵ Left turn signal indicator light
- ㊶ Right turn signal indicator light
- ㊷ Meter light
- ㊸ Oil level switch
- ㊹ Left handlebar switch
- ㊺ Clutch switch
- ㊻ Pass switch
- ㊼ Dimmer switch
- ㊽ Windshield position switch
- ㊾ Turn signal switch
- ㊿ Horn switch
- ① Horn
- ② Front turn signal light (left)
- ③ Front turn signal light (right)
- ④ Hazard switch
- ⑤ Headlight relay 1
- ⑥ Headlight relay 2
- ⑦ Headlight assembly
- ⑧ Auxiliary light
- ⑨ Headlight
- ⑩ Taillight assembly
- ⑪ Tail/brake light
- ⑫ Rear turn signal light (left)
- ⑬ Rear turn signal light (right)
- ⑭ Rear brake light switch
- ⑮ Turn signal relay
- ⑯ Windshield drive unit
- ⑰ Radiator fan motor
- ⑱ Radiator fan motor relay
- ⑲ Parking lighting fuse
- ⑳ Hazard lighting fuse
- ㉑ Ignition fuse
- ㉒ Headlight fuse
- ㉓ Signaling system fuse
- ㉔ Radiator fan motor fuse
- ㉕ Windshield motor fuse

- ⑶ CYCLELOCK
- ⑷ Right handlebar switch
- ⑸ Front brake light switch
- ⑹ Light switch
- ⑺ Engine stop switch
- ⑻ Start switch
- ⑽ Fuel injection system relay

COLOR CODE

- B.....Black
- Br.....Brown
- Ch.....Chocolate
- Dg.....Dark green
- G.....Green
- Gy.....Gray
- L.....Blue
- Lg.....Light green
- O.....Orange
- P.....Pink
- R.....Red
- Sb.....Sky blue
- W.....White
- Y.....Yellow
- B/L.....Black/Blue
- B/R.....Black/Red
- B/W.....Black/White
- B/Y.....Black/Yellow
- Br/B.....Brown/Black
- Br/G.....Brown/Green
- Br/L.....Brown/Blue
- Br/R.....Brown/Red
- Br/W.....Brown/White
- Br/Y.....Brown/Yellow
- G/B.....Green/Black
- G/L.....Green/Blue
- G/W.....Green/White
- G/Y.....Green/Yellow
- Gy/G.....Gray/Green
- Gy/R.....Gray/Red
- L/B.....Blue/Black
- L/G.....Blue/Green
- L/R.....Blue/Red
- L/W.....Blue/White
- L/Y.....Blue/Yellow
- O/B.....Orange/Black
- P/W.....Pink/White
- R/B.....Red/Black
- R/G.....Red/Green
- R/L.....Red/Blue
- R/W.....Red/White
- R/Y.....Red/Yellow
- W/B.....White/Black
- W/Y.....White/Yellow
- Y/B.....Yellow/Black
- Y/G.....Yellow/Green
- Y/L.....Yellow/Blue

FJR1300 WIRING DIAGRAM (for Oceania)

- ① Main switch
- ② Rectifier/regulator
- ③ Generator
- ④ Backup fuse (odometer, clock and windshield)
- ⑤ Main fuse
- ⑥ Battery
- ⑦ Fuel injection system fuse
- ⑧ Starter relay
- ⑨ Starter motor
- ⑩ Diode
- ⑪ Starting circuit cut-off relay
- ⑫ Neutral switch
- ⑬ Sidestand switch
- ⑭ Fuel pump
- ⑮ O₂ sensor
- ⑯ Cylinder identification sensor
- ⑰ Throttle position sensor
- ⑱ Intake air pressure sensor
- ⑲ Atmospheric pressure sensor
- ⑳ Lean angle cut-off switch
- ㉑ Intake air temperature sensor
- ㉒ Coolant temperature sensor
- ㉓ Crankshaft position sensor
- ㉔ ECU
- ㉕ Cylinder #1 - injector
- ㉖ Cylinder #2 - injector
- ㉗ Cylinder #3 - injector
- ㉘ Cylinder #4 - injector
- ㉙ AI system solenoid
- ㉚ Cylinder #1, #4 - ignition coil
- ㉛ Cylinder #2, #3 - ignition coil
- ㉜ Spark plug
- ㉝ Speed sensor
- ㉞ Meter assembly
- ㉟ Oil level warning light
- ⓫ Neutral indicator light
- ⓬ Multi-function meter
- ⓭ Engine trouble warning light
- ⓮ High beam indicator light
- ⓯ Left turn signal indicator light
- ⓰ Right turn signal indicator light
- ⓱ Meter light
- ⓲ Oil level switch
- ⓳ Left handlebar switch
- ⓴ Clutch switch
- ⓵ Pass switch
- ⓶ Dimmer switch
- ⓷ Windshield position switch
- ⓸ Turn signal switch
- ⓹ Horn switch
- ⓺ Horn
- ⓻ Front turn signal light (left)
- ⓼ Front turn signal light (right)
- ⓽ Hazard switch
- ⓾ Headlight relay 1
- ⓿ Headlight relay 2
- ⓿ Headlight assembly
- ⓿ Headlight
- ⓿ Taillight assembly
- ⓿ Tail/brake light
- ⓿ Rear turn signal light (left)
- ⓿ Rear turn signal light (right)
- ⓿ Rear brake light switch
- ⓿ Turn signal relay
- ⓿ Windshield drive unit
- ⓿ Radiator fan motor
- ⓿ Radiator fan motor relay

- ⓿ Ignition fuse
- ⓿ Headlight fuse
- ⓿ Signaling system fuse
- ⓿ Radiator fan motor fuse
- ⓿ Windshield motor fuse
- ⓿ Right handlebar switch
- ⓿ Front brake light switch
- ⓿ Engine stop switch
- ⓿ Start switch
- ⓿ Fuel injection system relay

COLOR CODE

- B Black
- Br Brown
- Ch Chocolate
- Dg Dark green
- G Green
- Gy Gray
- L Blue
- Lg Light green
- O Orange
- P Pink
- R Red
- Sb Sky blue
- W White
- Y Yellow
- B/L Black/Blue
- B/R Black/Red
- B/W Black/White
- B/Y Black/Yellow
- Br/B Brown/Black
- Br/G Brown/Green
- Br/L Brown/Blue
- Br/R Brown/Red
- Br/W Brown/White
- Br/Y Brown/Yellow
- G/B Green/Black
- G/L Green/Blue
- G/W Green/White
- G/Y Green/Yellow
- Gy/G Gray/Green
- Gy/R Gray/Red
- L/B Blue/Black
- L/G Blue/Green
- L/R Blue/Red
- L/W Blue/White
- L/Y Blue/Yellow
- O/B Orange/Black
- P/W Pink/White
- R/B Red/Black
- R/G Red/Green
- R/L Red/Blue
- R/W Red/White
- R/Y Red/Yellow
- W/B White/Black
- W/Y White/Yellow
- Y/B Yellow/Black
- Y/G Yellow/Green
- Y/L Yellow/Blue

FJR1300 WIRING DIAGRAM (for Oceania)

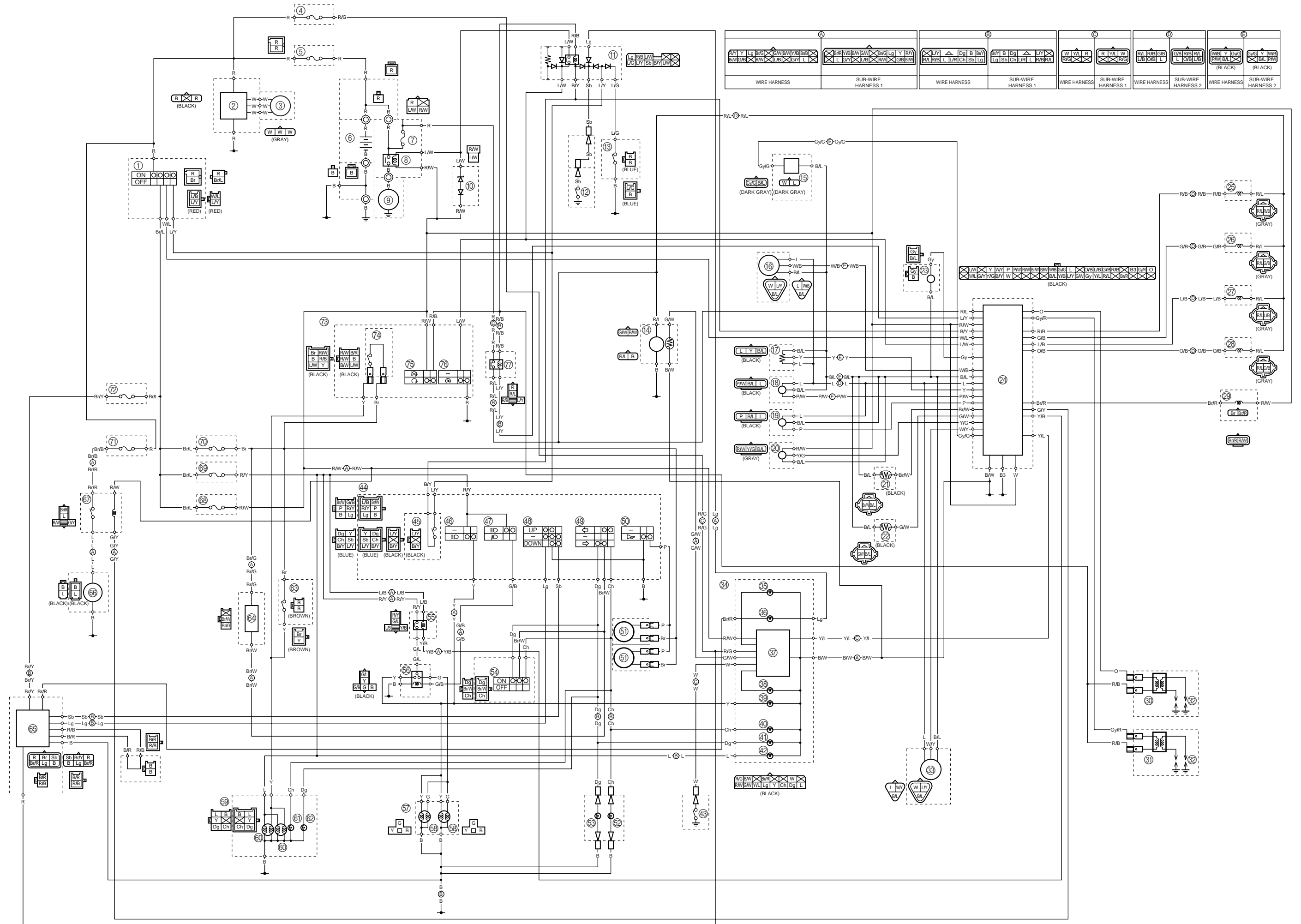

FJR1300R WIRING DIAGRAM

- Colour Code:
- B.....Black
 - Br.....Brown
 - Ch.....Chocolate
 - Dg.....Dark Green
 - G.....Green
 - Gy.....Gray
 - L.....Blue
 - Lg.....Light Green
 - O.....Orange
 - P.....Pink
 - R.....Red
 - Sb.....Sky Blue
 - W.....White
 - Y.....Yellow

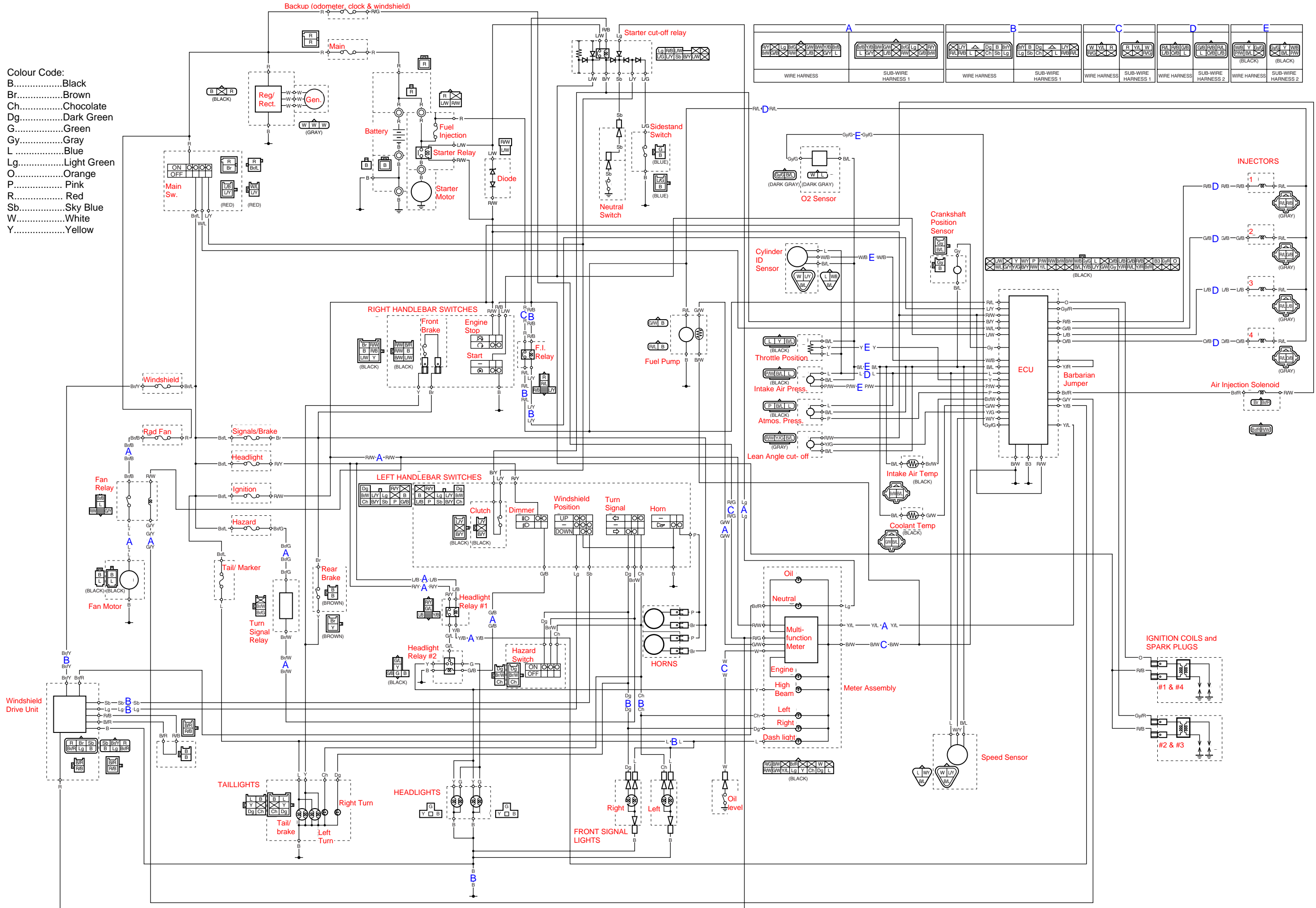

The "Barbarian Jumper Mod"

[Index](#) [Home](#)

Tom Barber (aka **Barbarian**) and Dwayne Verhey (aka **Torch**) from the [FJROwners online forum](#) figured out how to enable a North American spec'd FJR1300 to have it's EFI's CO setting adjusted, like the European and OZ/NZ models allow. On 03/05/03 Torch provided the following text and photos:

Note: there is a companion Web page documenting [how to adjust the CO setting](#).

The FJR has the capability to adjust the overall fuel injector map for each individual cylinder right from the dashboard. The procedure is well-documented in the European and Oceanic service manuals, and requires the use of CO measuring instruments.

But the Yamaha decided to lock out this capability in the bikes they shipped to North America. It was a conscious decision: they will tell a dealer how to override the lock-out if the dealer can prove the need, but it's a big secret from everyone else.

Not any more. This will explain how you can Europeanize (is that a word?) your FJR so you can have it properly serviced at any shop. Or even at home if you have the proper equipment. All you have to do is move one little wire: the Barbarian Jumper (named after the nickname of the fellow who discovered it.)

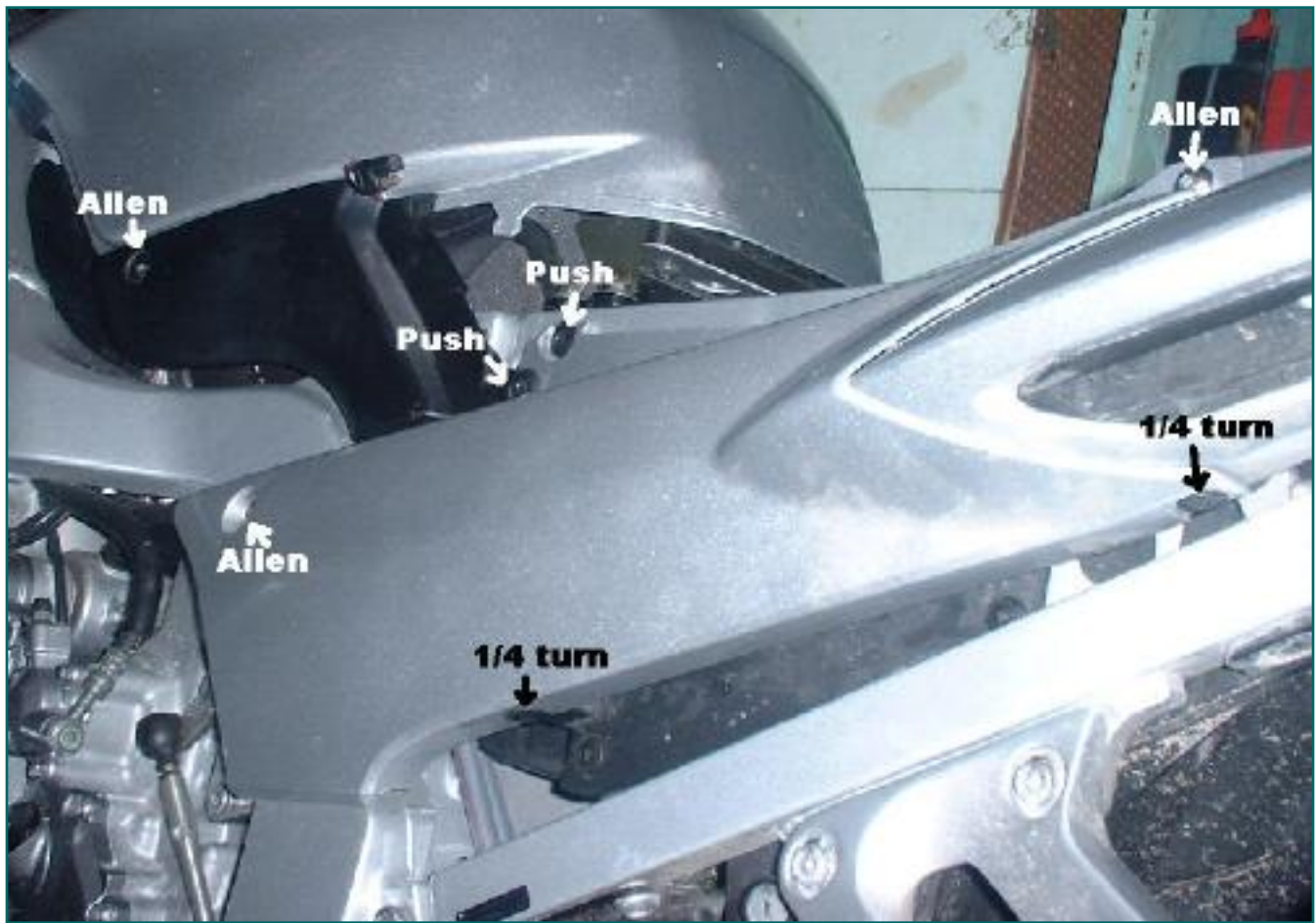

First, remove the seat and two left sidecovers. As with the dash panels, Yamaha used a variety of fasteners on this job, including Allen head fasteners, push-pin fasteners, and 1/4 turn Philips head fasteners. See your owner's manual for a more complete description of removing each. Don't forget the two underneath the sidecover.



Next, remove the airbox cover. At least all 4 of these are the same 1/4 turn fastener. Unfortunately, the one indicated by the screwdriver is recessed and a PITA.

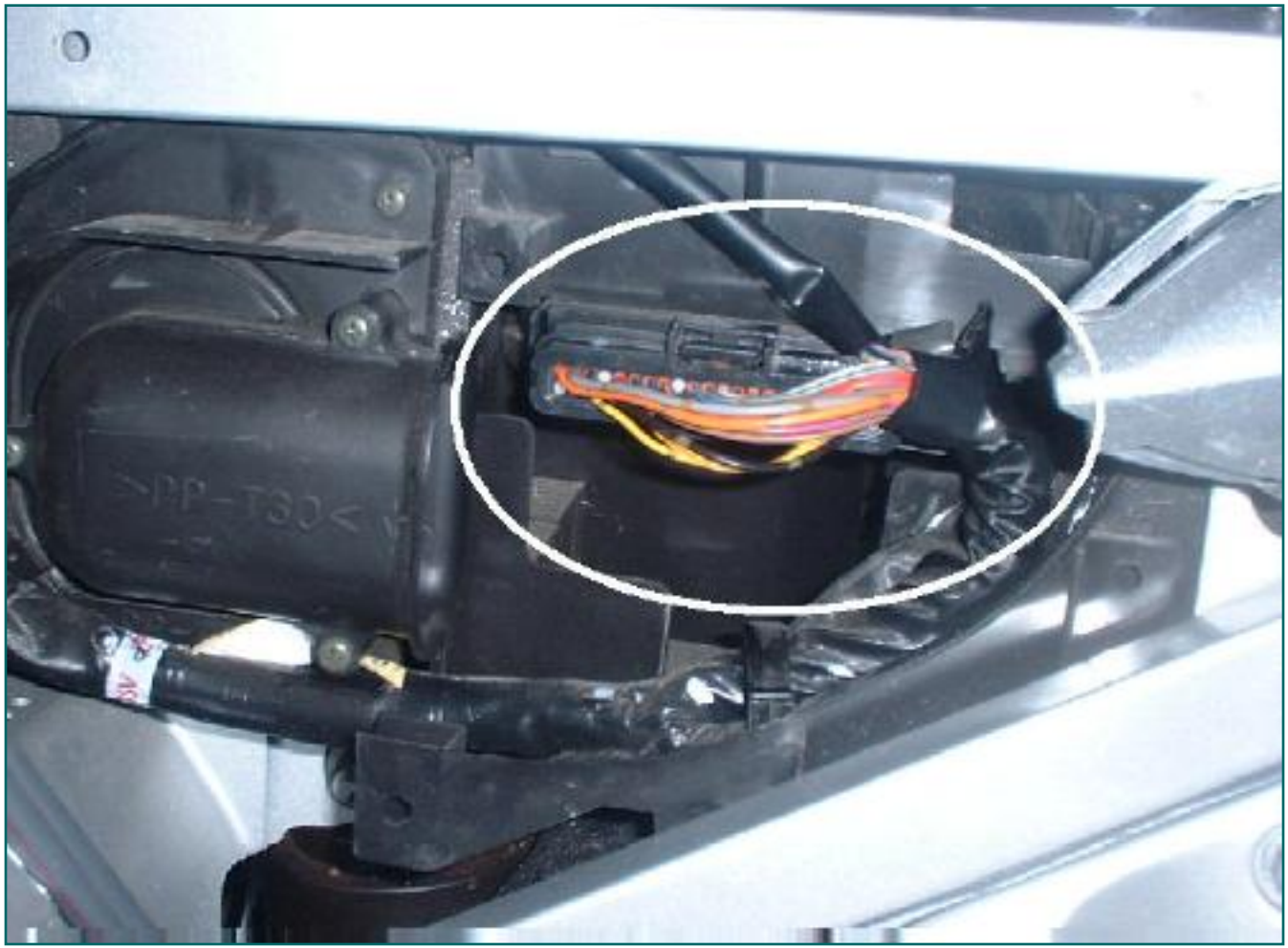

With the covers out of the way, the ECU is now accessible. Squeeze the black latch on the top of the connector as you pull it out of the ECU.

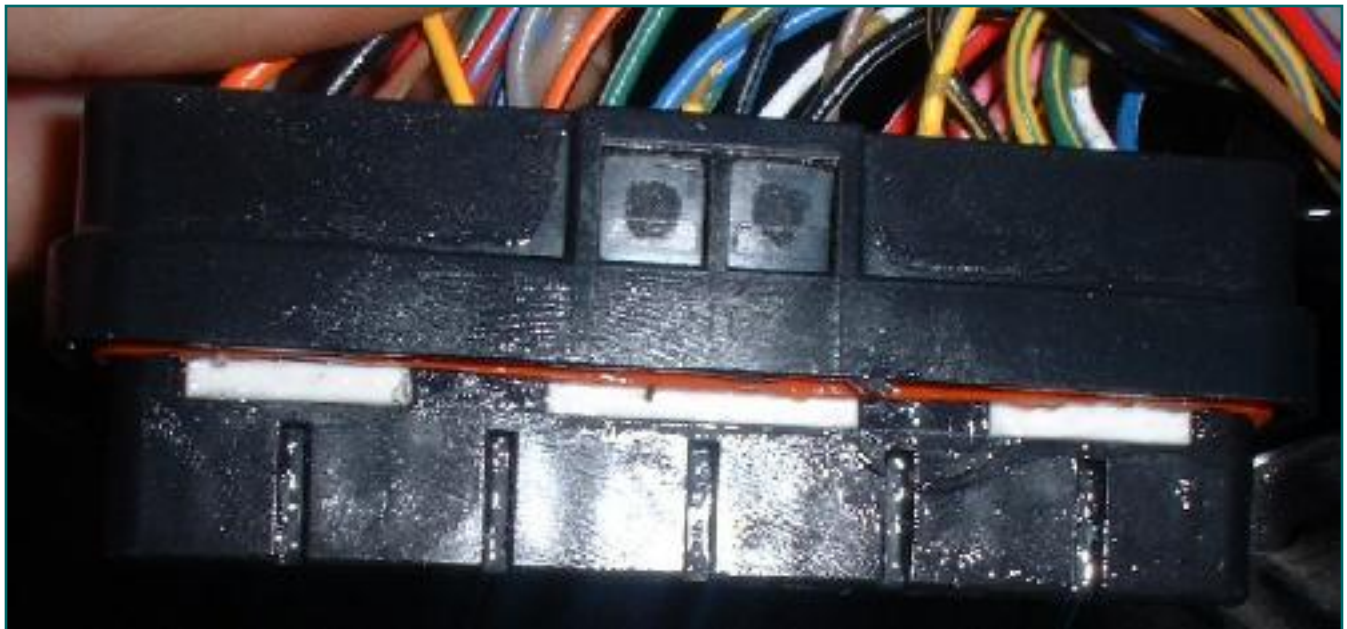

On the underside of the connector are 3 white bars. Using a fingernail or

small screwdriver, push the left one (as pictured) in about 1/32". This unlocks the wires in the connector.

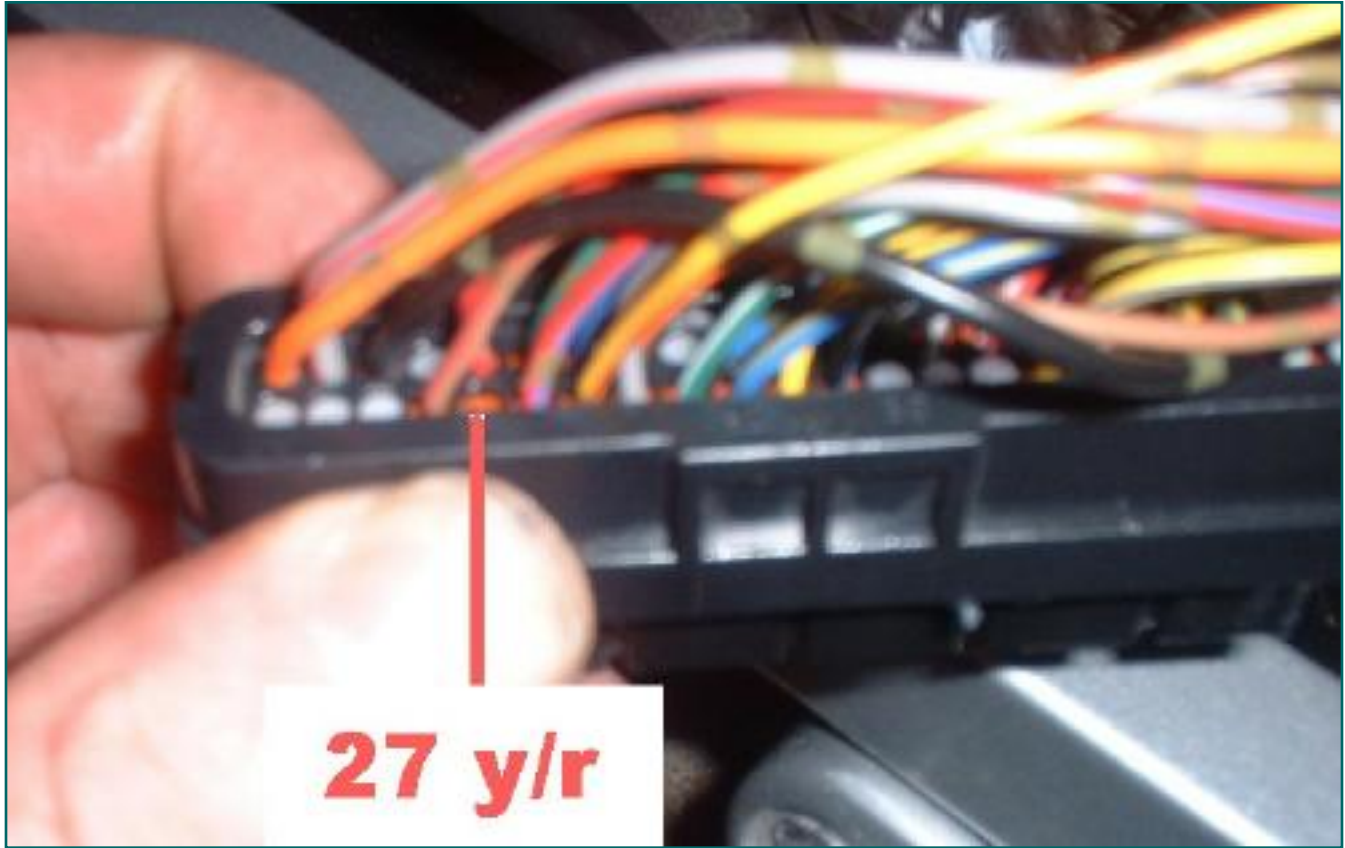

Pin #27 is the 5th from the left on the bottom row. It houses a yellow wire with a red stripe -- 1/2 of the Barbarian Jumper. Carefully remove this wire from the connector. Make sure you have the wire for pin 27 -- the other half of the jumper is only 2 pins away at 29, and we want to leave that half there.

Do not pull on wires -- if they are pulled even slightly out you will not be able to re-lock the connector. Also, the metal terminal ends are very fragile and difficult to replace if you separate the wire from the terminal. Push the wire out gently as shown in the next picture."

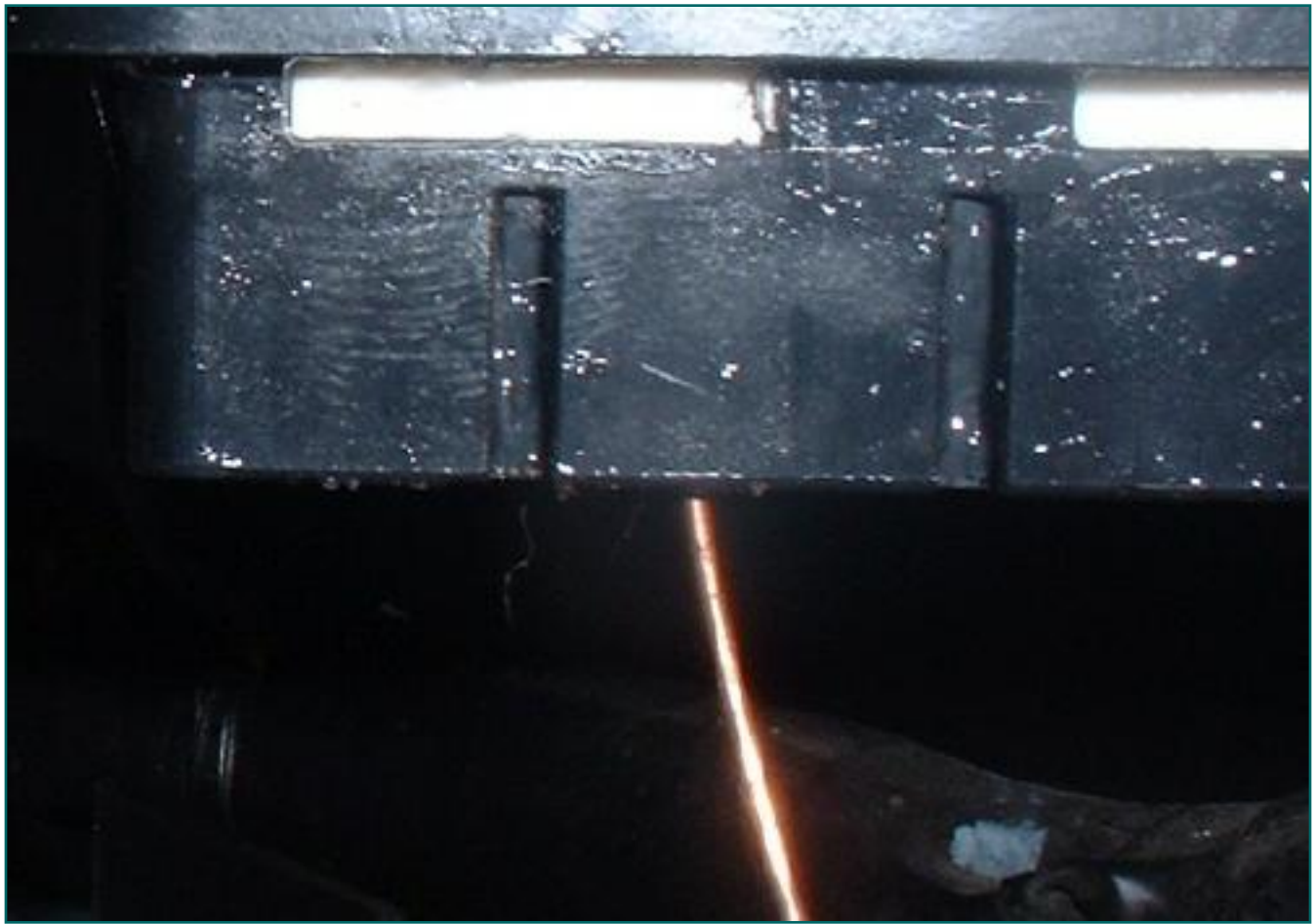

Using a small piece of stiff wire (I used some .030 MIG wire, but a paperclip or safety pin would probably work) gently push up from the ECU side of the connector to lift the wire to pin 27 and the white plug in pin 25. Do not force anything! The metal terminal ends on the wires are fragile and easily damaged. Lift the pin out with tweezers or needlenose pliers.



The plug is small. Very small. And bouncy. It can travel a surprising distance when deflected off the airbox. If you drop it you are in for more fun than a snipe hunt. Do not ask me how I know this. Use tweezers.



Put the plug in pin 27. Put the wire you removed in pin 25. Make sure they are fully seated and then re-lock the connector by pressing the left hand (as

pictured) white bar on the top of the connector down until flush (about 1/32") It does not take a lot of force, so if it doesn't want to go you probably have a wire pulled slightly out. Make sure all the wires in the left 1/3 of the connector are fully seated and try again.

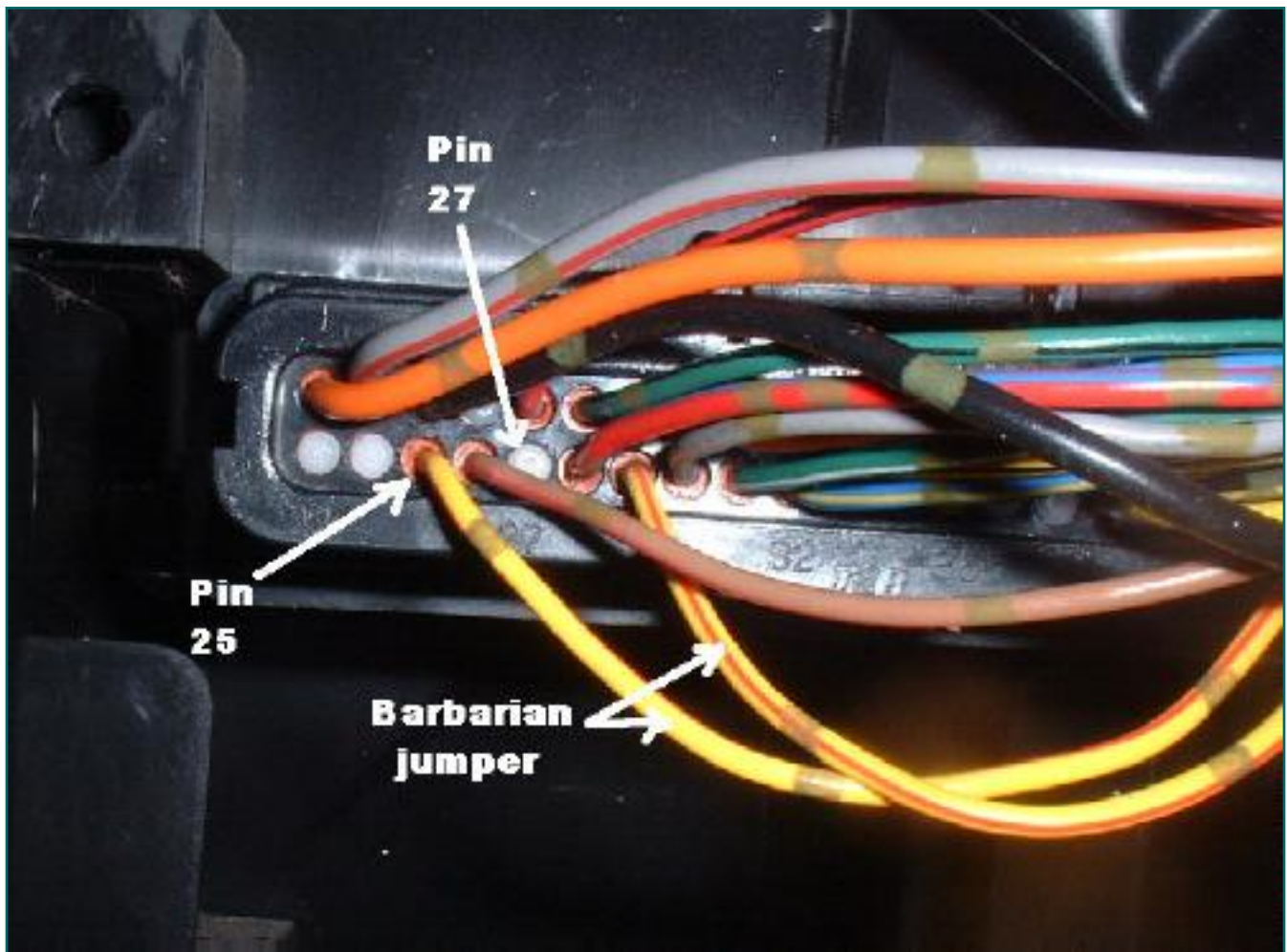

When you are all done, insert the connector into the ECU until the latch clicks. If you did it right, it should look like this now. Your FJR1300 is now ready for you to tackle the [CO Adjustment procedure](#), documented here also. Note: No ECUs were harmed in the making of this web page.

Before attempting this mod there was a great deal of discussion and analysis (on the [FJROwners](#) online forum) of the comparative wiring diagrams and possible operating parameters of the unit. Then the signal levels of the various ECU pins were sampled with a high impedance probe and oscilloscope to clarify any ambiguities.

I may be curious, but I ain't stupid.

Nonetheless: all the standard disclaimers apply: Do this at your own risk. I am not responsible if you let the smoke out of your ECU. YMMV. Etc.

-- Torch.

Copyright © 2003, by H. Marc Lewis, Tom Barber, and Dwayne Verhey.
All rights reserved.

Installing Riv-Nut ports in the FJR's Headers

[Index](#) [Home](#)

On 03/05/03 Dwayne Verhey (aka **Torch**) from the [FJROwners online forum](#) wrote this Web page describing how to install "[Riv-nuts](#)" into the FJR1300's header pipes. This is required to properly modify the EFI's CO setting, like the European and OZ/NZ models allow.

Note: there are companion Web pages documenting how to do the [Barbarian Jumper mod](#) and how to [adjust the CO setting](#).



These are [riv-nuts](#) (or rivet nuts, or thread inserts depending on the manufacturer.) They are a hollow, threaded rivet that can be installed on the headers "blind" -- that is, without removing the headers. Yamaha instructs North American dealers to install these if it is necessary to check the CO adjustment of the fuel injection system.

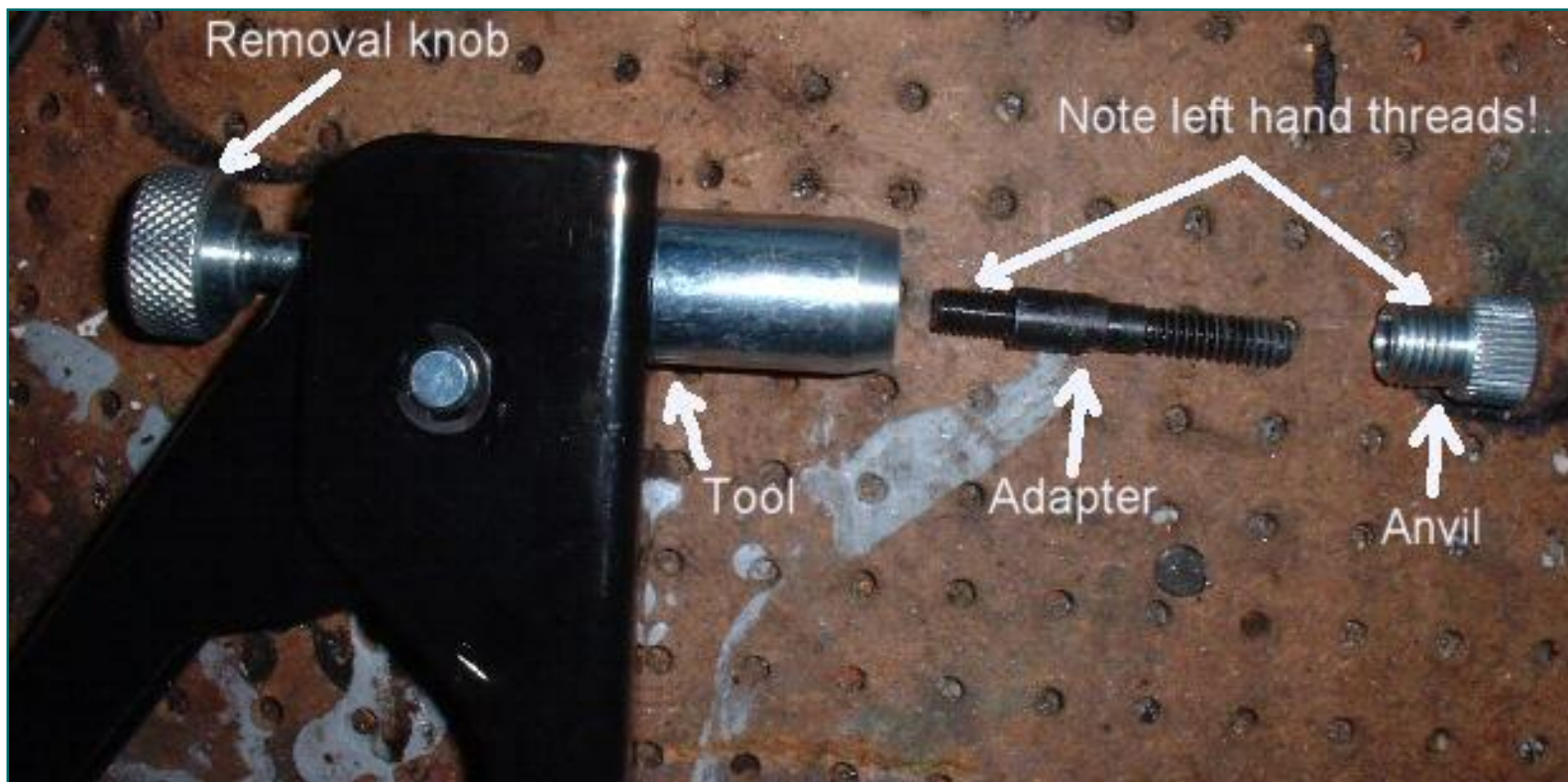

This is a riv-nut tool. Similar to a standard pop rivet gun, but with interchangeable adapters and anvils sized for the insert being installed. The appropriate adapter is screwed into the tool, followed by the corresponding anvil. In use the riv-nut is threaded onto the adapter, inserted into the hole, and compressed against the anvil when the handle is squeezed to draw the adapter inwards. After installation, the removal knob is turned counter-clockwise to unscrew the adapter from the insert.



First a hole is drilled into the pipe where the port is required. European and Oceanic models have ports installed from the factory. Migmagal reports they are located "About 5 inches after the cylinder exits on each tube" and Woody concurs saying they are "about 125mm from the top of the exhaust ports". For clarity, these pictures are of a sample installed on a piece of scrap 1 1/2" exhaust pipe.

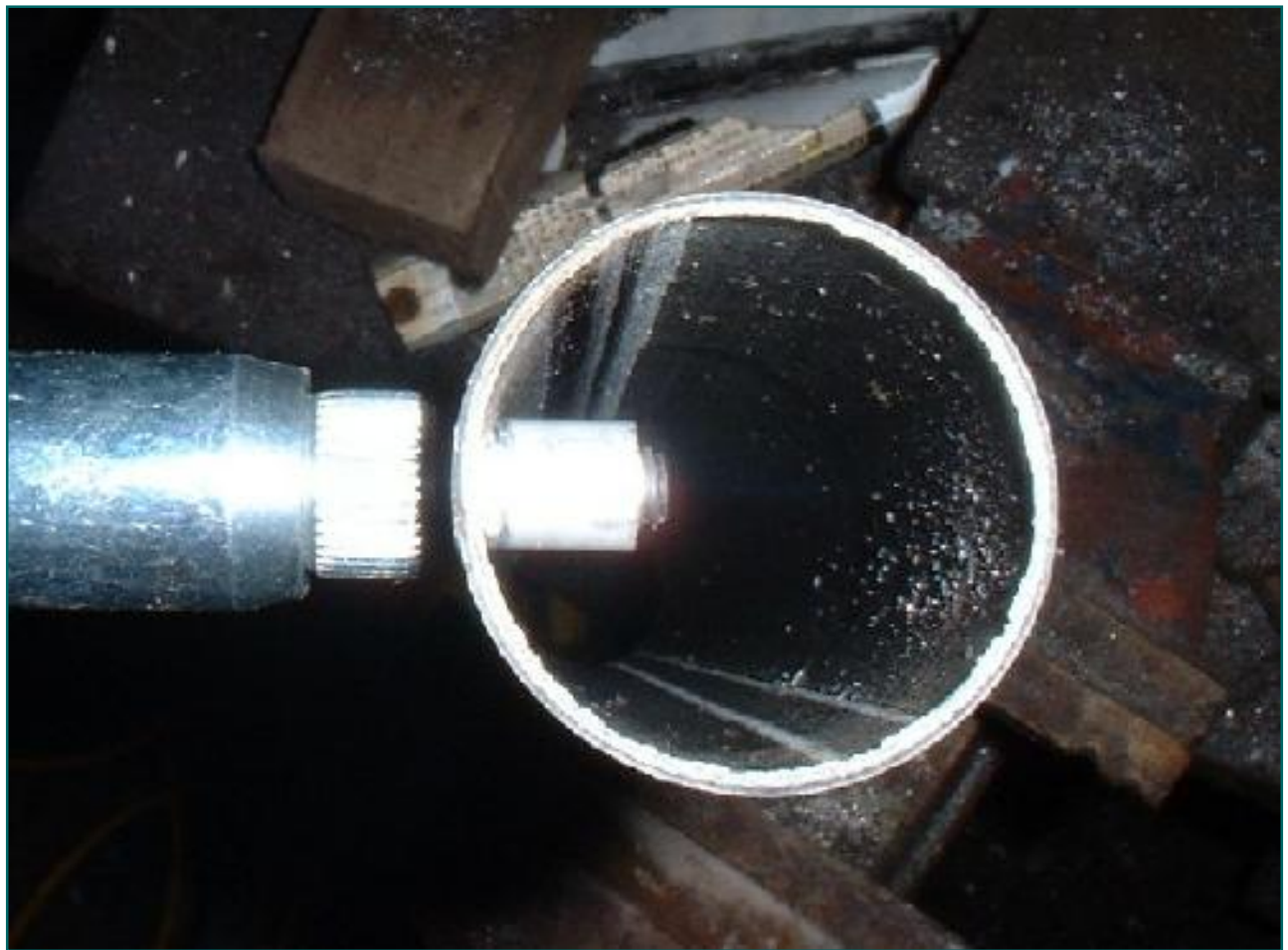

Here the riv-nut is assembled on the tool and inserted into the hole ready to go. One squeeze of the handle is sufficient. Attempting to compress the riv-nut further will only strip the threads. As described earlier, unscrew the tool from the insert using the removal knob.



The end result. The upper portion of the riv-nut has been mushroomed firmly against the wall of the pipe, following the curve, providing a threaded port. I chose 1/4"-20 NCT aluminium inserts for this example. Following this I inserted an oxy-acetelene torch into the other end and adjusted it so flames were shooting out the end past the insert and left it until the pipe started to glow a dull red through most of it's length. The aluminium was unaffected, but I think I would still choose steel or stainless inserts for the real installation to avoid corrosion of dissimilar metals.



The hole is sealed with a bolt when not in use. As can be seen from this picture, the bolt may protrude into the pipe unless cut to length. Besides being a potential for further restriction, the exposed threads could become clogged with carbon deposits from the exhaust making future removal difficult or impossible. I suggest trimming the bolt to avoid problems.

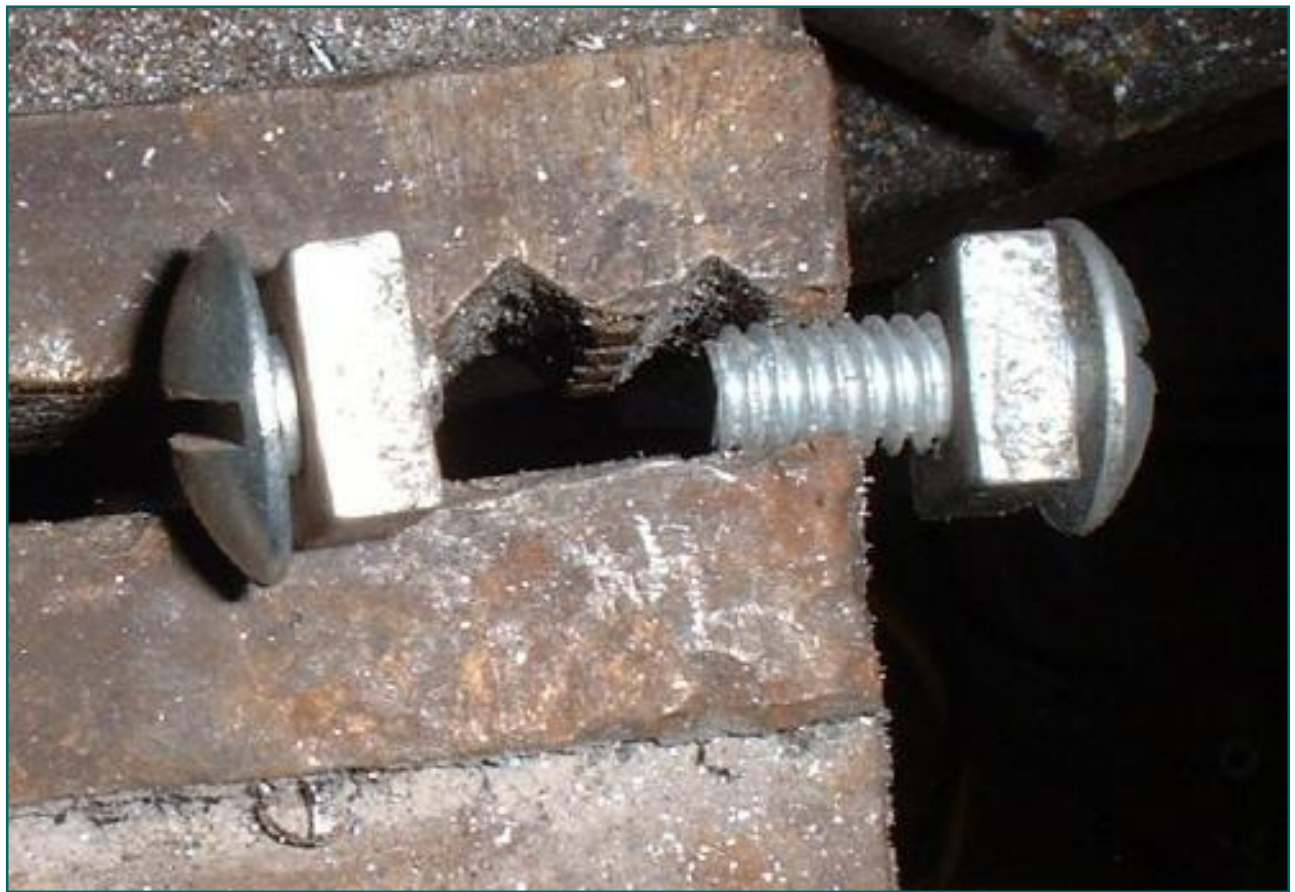

When cutting a thread, it's a good idea to temporarily install a nut first. Cut the thread off beyond the nut, then wind the thread past the end of the nut. If the thread binds while removing the nut, make sure the thread is not protruding past the nut and simply tap it against something solid to re-form the thread. In this case, because the bolt is now so short, it was easier to set it on the anvil of the vice and tap gently with a hammer.

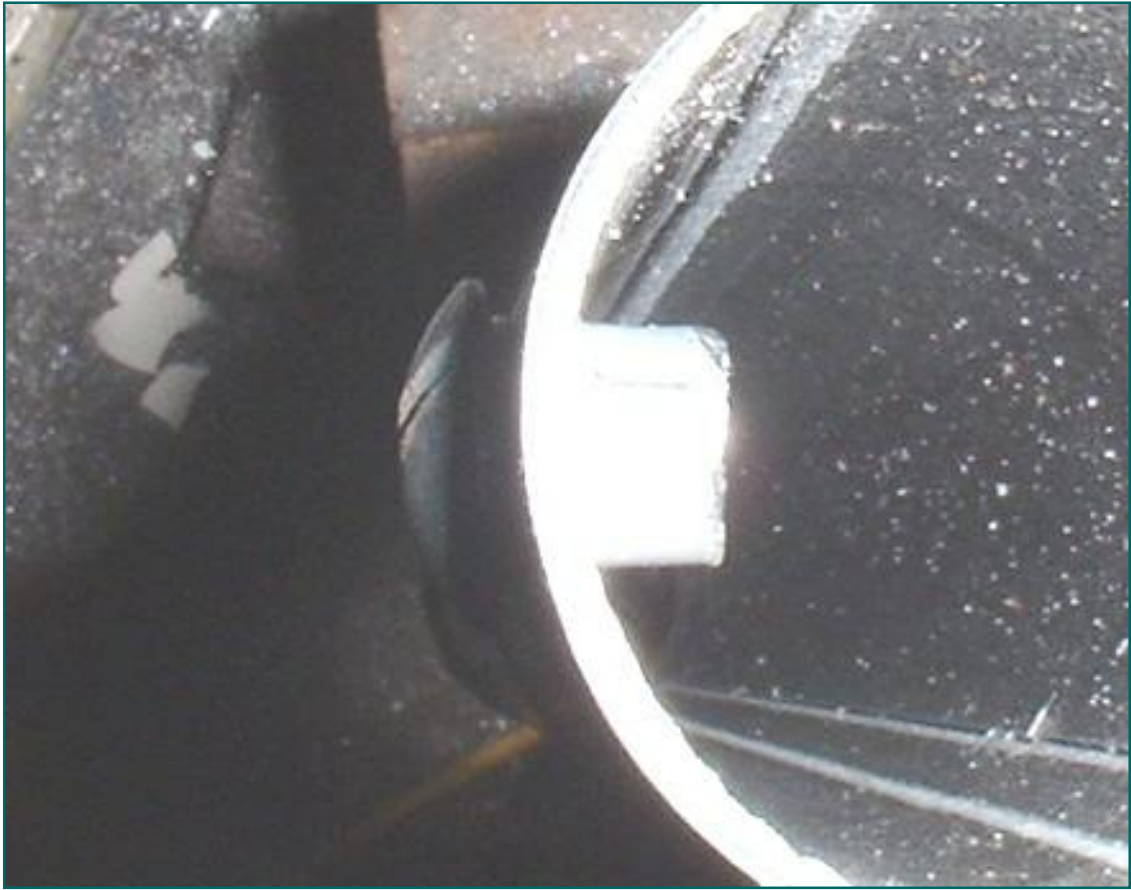

The trimmed bolt no longer protrudes into the pipe.



In an effort to reduce any possible restriction, I tried cutting 1/2 the threaded portion of a riv-nut off before installing it. The threads stripped out before it fully mushroomed, resulting in this failed installation on the right. The insert is loose, but cannot be removed and there are no threads left to seal it! The full threaded length is required to properly install the insert.

Following Fastwally's description of the procedure given his Yamaha dealer, we have all kind of been hung up on the riv-nut idea, myself included.



With all due respect to Yamaha, I offer this option which has no restriction to exhaust flow. I drilled a 33/64" hole in the pipe, threaded a bolt through a nut, inserted the protruding thread through the hole, and welded the nut to the pipe. The bolt can then be withdrawn and cut to length. For the real thing, spring for a stainless nut.

Caution: before arc welding on a motorcycle, unplug the ECU and disconnect the battery!

Also visible in this picture is a bolt installed in the riv-nut.

(note: I also recommend remembering to turn on the argon before MIG welding! The result will be much stronger and prettier that way. What can I say -- it was a

long night ;-)

-- *torch*

Copyright © 2003, by H. Marc Lewis and Dwayne Verhey.
All rights reserved.