

**YAMAHA** PORTATONE

**PSR-410**

**Owner's Manual**



# SPECIAL MESSAGE SECTION

This product utilizes batteries or an external power supply (adapter). DO NOT connect this product to any power supply or adapter other than one described in the manual, on the name plate, or specifically recommended by Yamaha.

This product should be used only with the components supplied or; a cart, rack, or stand that is recommended by Yamaha. If a cart, etc., is used, please observe all safety markings and instructions that accompany the accessory product.

## SPECIFICATIONS SUBJECT TO CHANGE:

The information contained in this manual is believed to be correct at the time of printing. However, Yamaha reserves the right to change or modify any of the specifications without notice or obligation to update existing units.

This product, either alone or in combination with an amplifier and headphones or speaker/s, may be capable of producing sound levels that could cause permanent hearing loss. DO NOT operate for long periods of time at a high volume level or at a level that is uncomfortable. If you experience any hearing loss or ringing in the ears, you should consult an audiologist.

**IMPORTANT:** The louder the sound, the shorter the time period before damage occurs.

## NOTICE:

Service charges incurred due to a lack of knowledge relating to how a function or effect works (when the unit is operating as designed) are not covered by the manufacturer's warranty, and are therefore the owners responsibility. Please study this manual carefully and consult your dealer before requesting service.

## ENVIRONMENTAL ISSUES:

Yamaha strives to produce products that are both user safe and environmentally friendly. We sincerely believe that our products and the production methods used to produce them, meet these goals. In keeping with both the letter and the spirit of the law, we want you to be aware of the following:

## Battery Notice:

This product MAY contain a small non-rechargeable battery which (if applicable) is soldered in place. The average life span of this type of

battery is approximately five years. When replacement becomes necessary, contact a qualified service representative to perform the replacement.

This product may also use "household" type batteries. Some of these may be rechargeable. Make sure that the battery being charged is a rechargeable type and that the charger is intended for the battery being charged.

When installing batteries, do not mix batteries with new, or with batteries of a different type. Batteries MUST be installed correctly. Mismatches or incorrect installation may result in overheating and battery case rupture.

## Warning:

Do not attempt to disassemble, or incinerate any battery. Keep all batteries away from children. Dispose of used batteries promptly and as regulated by the laws in your area. Note: Check with any retailer of household type batteries in your area for battery disposal information.

## Disposal Notice:

Should this product become damaged beyond repair, or for some reason its useful life is considered to be at an end, please observe all local, state, and federal regulations that relate to the disposal of products that contain lead, batteries, plastics, etc. If your dealer is unable to assist you, please contact Yamaha directly.

## NAME PLATE LOCATION:

The name plate is located on the bottom of the product. The model number, serial number, power requirements, etc., are located on this plate. You should record the model number, serial number, and the date of purchase in the spaces provided below and retain this manual as a permanent record of your purchase.

**Model**

---

**Serial No.**

---

**Purchase Date**

---

# PLEASE KEEP THIS MANUAL

## FCC INFORMATION (U.S.A.)

### IMPORTANT NOTICE: DO NOT MODIFY THIS UNIT!

This product, when installed as indicated in the instructions contained in this manual, meets FCC requirements. Modifications not expressly approved by Yamaha may void your authority, granted by the FCC, to use the product.

### IMPORTANT:

When connecting this product to accessories and/or another product use only high quality shielded cables. Cable/s supplied with this product MUST be used. Follow all installation instructions. Failure to follow instructions could void your FCC authorization to use this product in the USA.

### NOTE:

This product has been tested and found to comply with the requirements listed in FCC Regulations, Part 15 for Class "B" digital devices. Compliance with these requirements provides a reasonable level of assurance that your use of this product in a residential environment will not result in harmful interference with other electronic devices. This equipment generates/uses radio frequencies and, if not installed and used according to

the instructions found in the users manual, may cause interference harmful to the operation of other electronic devices. Compliance with FCC regulations does not guarantee that interference will not occur in all installations. If this product is found to be the source of interference, which can be determined by turning the unit "OFF" and "ON", please try to eliminate the problem by using one of the following measures:

- Relocate either this product or the device that is being affected by the interference.
- Utilize power outlets that are on different branch (circuit breaker or fuse) circuits or install AC line filter/s.
- In the case of radio or TV interference, relocate/reorient the antenna. If the antenna lead-in is 300 ohm ribbon lead, change the lead-in to co-axial type cable.

If these corrective measures do not produce satisfactory results, please contact the local retailer authorized to distribute this type of product. If you can not locate the appropriate retailer, please contact Yamaha Corporation of America, Electronic Service Division, 6600 Orangethorpe Ave, Buena Park, CA90620

- This applies only to products distributed by Yamaha Corporation of America.

# Congratulations!

You are the proud owner of a Yamaha PSR-410. Your PSR-410 is a high-quality musical instrument that incorporates advanced Yamaha digital technology and many versatile features. In order to obtain maximum performance and enjoyment from your PSR-410, we urge you to read this Owner's Manual thoroughly while trying out the various features described. Keep the Owner's Manual in a safe place for later reference.

## Contents

<b>Panel Controls</b>	2	<b>Registration Memory</b>	31
<b>Taking Care of Your PortaTone</b>	4	<b>Record Functions</b>	32
<b>Preparation</b>	5	<b>Song Memory</b> .....	32
■ Power Supply .....	5	■ Accompaniment Track Recording .....	33
■ Using Headphones Or an External Sound System .....	6	■ Melody Track Recording .....	35
■ The Sustain Pedal .....	6	■ Accompaniment And Melody Playback .....	36
■ The Music Stand .....	6	■ The [RESET] Button .....	37
<b>Listen to the Demo!</b>	7	■ Record Or Play from a Specified Measure .....	37
<b>Basic Editing Procedure</b>	8	<b>The Multi Pads</b> .....	38
<b>Selecting &amp; Playing the Voices</b>	10	■ Recording .....	38
■ Orchestration .....	10	■ Playback .....	39
■ Voice Assignment .....	12	<b>Clearing Tracks</b> .....	40
■ Volume .....	13	<b>Page Memory</b>	41
■ Octave .....	13	<b>MIDI</b>	42
■ Pan .....	14	<b>MIDI Bulk Dump</b> .....	43
■ Auto Harmony .....	15	■ Page Copy .....	44
■ Keyboard Percussion .....	16	<b>MIDI Reception Modes</b> .....	45
■ Pitch Bend .....	17	■ Channel Reception Modes .....	45
■ Sustain .....	17	■ Clock Mode .....	46
<b>Overall Control</b>	18	■ Start/Stop Mode .....	46
■ Split Point Change .....	18	<b>MIDI Transmission</b> .....	47
■ Transpose .....	19	■ MIDI Transmit Channels .....	47
■ Tuning .....	19	<b>Appendix</b> .....	48
■ Touch Response .....	19	■ Voice & Polyphony List .....	48
<b>Auto Accompaniment</b>	20	■ Style List .....	49
■ Selecting a Style .....	20	■ Reset Procedures & Page Memory Default Settings ....	51
■ Setting the Auto Accompaniment Split Point .....	21	■ Troubleshooting .....	53
■ Auto Accompaniment Fingering .....	21	<b>Index</b> .....	54
■ Tempo Control .....	24		
■ Accompaniment Control .....	25		
■ Accompaniment Volume .....	27		
■ The Track Buttons .....	28		
■ Re-voicing the Tracks .....	29		
<b>One Touch Setting</b>	30		
		Percussion Kit List .....	218
		MIDI Implementation Chart .....	220
		Specifications .....	223

## Top Panel Controls

- ❶ POWER Button ..... page 7
- ❷ MASTER VOLUME Control ..... page 7
- ❸ MULTI DISPLAY ..... page 7,8
- ❹ [+], [-] Buttons ..... page 9
- ❺ Number Buttons [0]~[9], [+/-] ..... page 9
- ❻ ARE YOU SURE ? [YES], [NO] Buttons  
..... page 40, 43, 44
- ❼ PITCH BEND Wheel ..... page 17
- ❽ PAGE MEMORY Section
  - PAGE# Button ..... page 41
  - MIDI BULK DUMP/PAGE COPY Button ... page 43, 44
- ❾ OVERALL CONTROL Section
  - TEMPO Button ..... page 24
  - METRONOME Button ..... page 24
  - SPLIT POINT Button ..... page 18
  - TRANSPOSE Button ..... page 19
  - TUNING Button ..... page 19
  - TOUCH RESPONSE Button ..... page 19
- ❿ MIDI Section
  - RECEIVE CH/CL/COM Button ..... page 45, 46
  - TRANSMIT CH Button ..... page 47
- ⓫ AUTO ACCOMPANIMENT Section
  - STYLE SELECT Button ..... page 20
  - AUTO ACCOMP Button ..... page 21
  - FINGERING Button ..... page 21
  - ACCOMP VOLUME Button ..... page 27
  - REVOICE Button ..... page 29
  - TRACK (RHYTHM1, 2, BASS,  
RHYTHMIC CHORD 1, 2, PAD  
CHORD, PHRASE1, 2) Buttons ..... page 28
- ⓬ ACCOMPANIMENT CONTROL Section
  - SYNC-START/STOP Button ..... page 25
  - START/STOP Button ..... page 25
  - INTRO Button ..... page 26
  - FILL IN 1 Button ..... page 26
  - FILL IN 2 Button ..... page 26
  - ENDING Button ..... page 27
  - MAIN A/B Buttons ..... page 26

- ⓭ VOICE Section
  - VOICE SELECT Button ..... page 12
  - KEYBOARD PERCUSSION Button ..... page 16
  - VOL Button ..... page 13
  - OCTAVE Button ..... page 13
  - PAN Button ..... page 14
  - ONE TOUCH SETTING Button ..... page 30
  - ORCHESTRATION R1, R2, L1, L2,  
EDIT Buttons ..... page 10, 11
  - HARMONY TYPE Button ..... page 15
  - HARMONY Button ..... page 15

The illustrations here are not available.

- 14 REGISTRATION MEMORY Section
  - MEMORIZE Button .....page 31
  - [1]~[4] Buttons .....page 31
- 15 SONG MEMORY Section
  - MEASURE# Button .....page 37
  - TRACK (ACCOMP, MELODY) Buttons . page 33~36
- 16 SONG Section
  - RESET Button .....page 37
  - PLAY/STOP Button .....page 36
- 17 RECORDING Section
  - REC Button..... page 33, 35, 38
  - CLEAR Button .....page 40

- 18 DEMO Section
  - SONG# Button .....page 7
  - START/STOP Button .....page 7
- 19 MULTI PADS Section
  - STOP Button .....page 39
  - PAD [1]~[4] Buttons ..... page 38, 39

## Rear Panel Connectors

- 20 MIDI OUT and IN Connectors .....page 42
- 21 SUSTAIN PEDAL Jack ..... page 6
- 22 HEADPHONES/AUX OUT Jack .....page 6
- 23 DC 10-12V IN Jack .....page 5

# Taking Care of Your PortaTone

Your PortaTone will give you years of playing pleasure if you follow the simple rules given below:

## ■ Location

Do not expose the instrument to the following conditions to avoid deformation, discoloration, or more serious damage.

- Direct sunlight (e.g. near a window).
- High temperatures (e.g. near a heat source, outside, or in a car during the daytime).
- Excessive humidity.
- Excessive dust.
- Strong vibration.

## ■ Power Supply

- Turn the power switch OFF when the instrument is not in use.
- A power adaptor, if used, should be unplugged from the AC outlet if the instrument is not to be used for an extended period of time.
- Unplug the power adaptor during electric storms.
- Avoid plugging the power adaptor into the same AC outlet as appliances with high power consumption, such as electric heaters or ovens. Also avoid using multi-plug adaptors since these can result in reduced sound quality and possibly damage.

## ■ Turn Power OFF When Making Connections

- To avoid damage to the instrument and other devices to which it is connected (a sound system, for example), turn the power switches of all related devices OFF prior to connecting or disconnecting audio and MIDI cables.

## ■ Handling and Transport

- Never apply excessive force to the controls, connectors or other parts of the instrument.
- Always unplug cables by gripping the plug firmly, not by pulling on the cable.
- Disconnect all cables before moving the instrument.
- Physical shocks caused by dropping, bumping, or placing heavy objects on the instrument can result in scratches and more serious damage.

## ■ Cleaning

- Clean the cabinet and panel with a dry soft cloth.
- A slightly damp cloth may be used to remove stubborn grime and dirt.
- Never use cleaners such as alcohol or thinner.
- Avoid placing vinyl objects on top of the instrument (vinyl can stick to and discolor the surface).

## ■ Electrical Interference

- This instrument contains digital circuitry and may cause interference if placed too close to radio or television receivers. If this occurs, move the instrument further away from the affected equipment.

## ■ Service and Modification

- The PSR-410 contains no user serviceable parts. Opening it or tampering with it in anyway can lead to irreparable damage and possibly electric shock. Refer all servicing to qualified YAMAHA personnel.

YAMAHA is not responsible for damage caused by improper handling or operation.

# Preparation

This section contains information about setting up your PSR-410 and preparing to play. Be sure to go through this section carefully before using your PSR-410.

The illustrations here are not available.

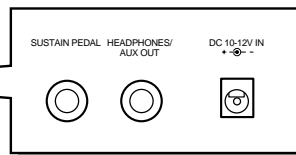

## Power Supply

Your PSR-410 will run either from an optional power adaptor or batteries\*. Follow the instructions below according to the power source you intend to use.

\* When batteries are used the sound of the PSR-410 may be distorted at high volume levels. This is because the power of the amplifier is reduced when batteries are used.



• **Never interrupt the power supply (e.g. remove the batteries or unplug the AC adaptor) during any PSR-410 record operation! Doing so can result in a loss of data.**

### ● Using An Optional AC Power Adaptor .....

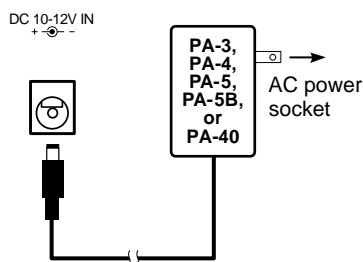

Plug the DC output cable from an optional Yamaha PA-3, PA-4, PA-5, PA-5B, or PA-40 AC Power Adaptor into the **DC IN** jack on the rear panel of the PSR-410, then plug the Power Adaptor (or the AC cable of the Power Adaptor) into a convenient wall AC power socket. The internal batteries are automatically disconnected when an AC Power Adaptor is used.



• **Use ONLY a Yamaha PA-3, PA-4, PA-5, PA-5B, or PA-40 AC Power Adaptor to power your instrument from the AC mains. The use of other adaptors may result in irreparable damage to both the adaptor and the PSR-410.**



• **Using the PA-5 with the PSR-410 will provide a slight increase in the overall volume.**

### ● Using Batteries .....

For battery operation the PSR-410 requires six 1.5V SUM-1, “D” size, R-20 or equivalent batteries.

When the batteries need to be replaced the volume may be reduced, the sound may be distorted, and other problems may occur. When this happens, turn the power off while either the batteries are replaced or an AC adaptor is connected.

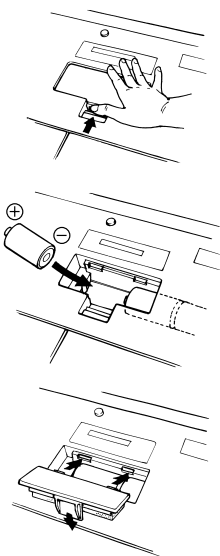

When the batteries fail, replace them as follows:

- 1 Open the battery compartment cover located on the instrument’s bottom panel.
- 2 Insert the six new batteries, being careful to follow the polarity markings on the inside of the compartment.
- 3 Replace the compartment cover, making sure that it locks firmly in place.



• **When the batteries run down, replace them with a complete set of six new batteries. NEVER mix old and new batteries.**

• **Do not use different kinds of batteries (e.g. alkaline and manganese) at the same time.**

• **To prevent possible damage due to battery leakage, remove the batteries from the instrument if it is not to be used for an extended period of time.**

# Preparation

## ■ Using Headphones Or an External Sound System

HEADPHONES/  
AUX OUT

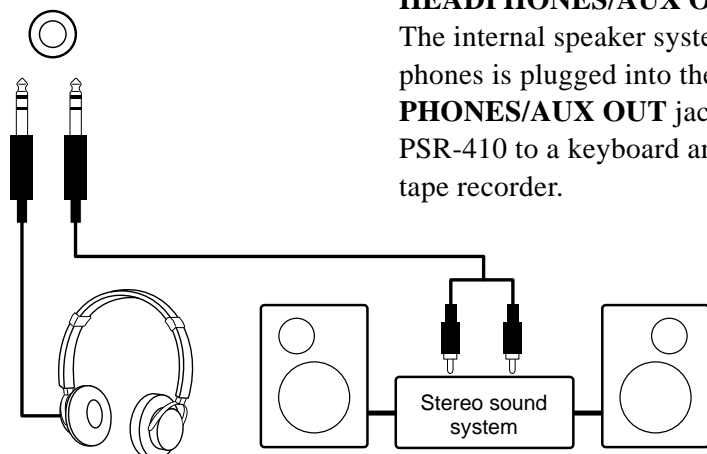

A standard pair of stereo headphones can be plugged into the rear-panel **HEADPHONES/AUX OUT** jack for private practice or late-night playing. The internal speaker system is automatically shut off when a pair of headphones is plugged into the **HEADPHONES/AUX OUT** jack. The **HEADPHONES/AUX OUT** jack can also be used to deliver the output of the PSR-410 to a keyboard amplifier, stereo sound system, mixing console or tape recorder.

## ■ The Sustain Pedal

SUSTAIN PEDAL

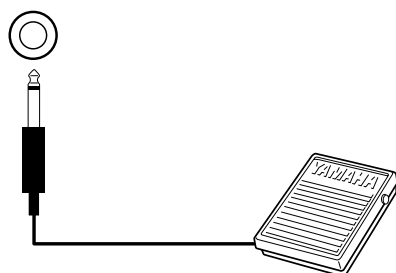

An optional Yamaha FC4 or FC5 footswitch can be plugged into the rear-panel **SUSTAIN PEDAL** jack. The sustain pedal functions as a damper pedal, controlling sustain. Press the pedal to sustain notes after the keys are released.



- *Be sure that you do not press the pedal while inserting the plug into the **SUSTAIN PEDAL** jack or while turning the power on. If you do, the **ON/OFF** status of the footswitch will be reversed. This function has been implemented to allow either **press-to-make** or **press-to-break** contact type footswitches to be used with the PSR-410.*

## ■ The Music Stand

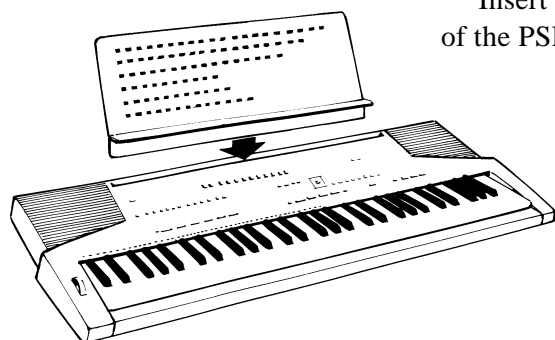

Insert the bottom edge of the music stand into the slot located at the rear of the PSR-410 control panel.

# Listen to the Demo!

Once you've set up your PSR-410, try listening to the pre-programmed demonstration songs — they'll give you a good idea of what the PSR-410 can do!

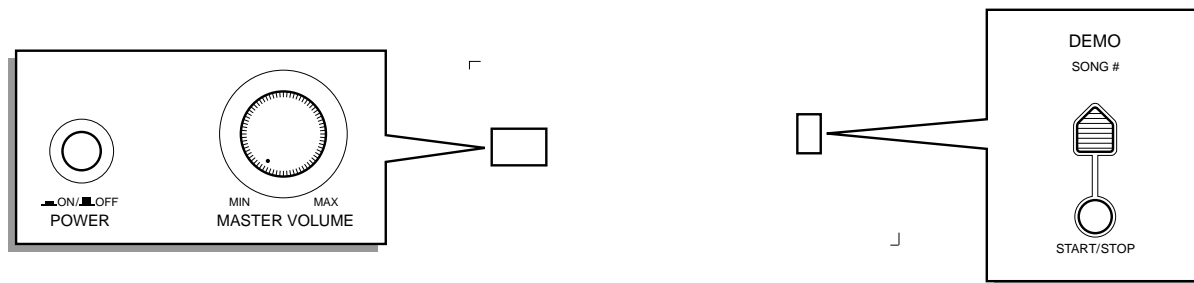

The illustrations here are not available.

## 1 Turn the Power ON & Set the Volume

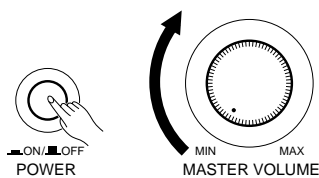

Before playing the demo turn the power ON by pressing the **POWER** switch (the panel indicators and MULTI DISPLAY will light), and turn the **MASTER VOLUME** control up (clockwise) about a quarter-turn from its minimum position.

## 2 Select a Song

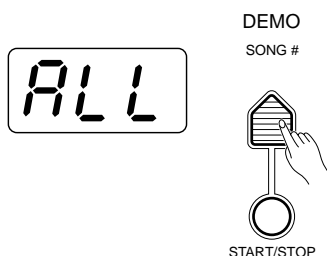

Press the DEMO [SONG #] button a few times until the number of the desired demo song appears on the MULTI DISPLAY.

- ALL (0):** Repeat playback of all demo songs in sequence.
- 1-5:** Repeat playback of the selected demo song number.



• "ALL" is automatically selected whenever the power switch is turned on.

## 3 Press DEMO [START/STOP] to Start

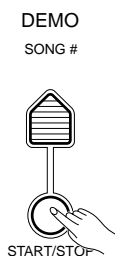

Press the DEMO [START/STOP] button to start playback, and use the MASTER VOLUME control to set the ideal listening level. The selected demonstration will play repeatedly.



• During demo playback you can select different voices and play along on the keyboard — see the "Selecting & Playing the Voices" section beginning on page 10.

## 4 Press DEMO [START/STOP] to Stop

Press the DEMO [START/STOP] button again to stop demo playback.

# Basic Editing Procedure

The PSR-410 features a flexible-but-consistent interface that lets you edit just about all of its parameters using the same basic procedure. Once familiar with the system, you'll be able to edit any parameter quickly and easily. Here's the basic procedure:

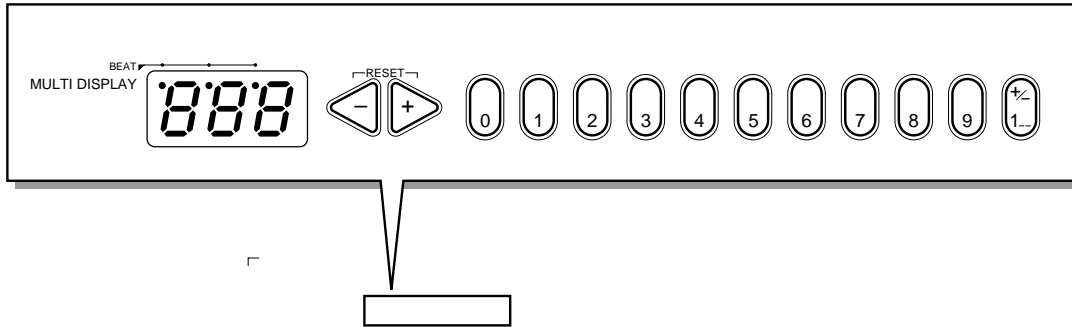

The illustrations here are not available.

## 1 Press a Function Button

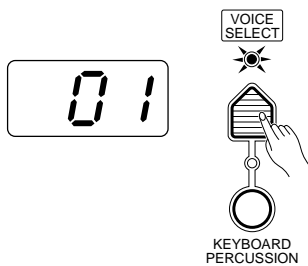

First press the button corresponding to the function or parameter you want to edit. To select voice numbers, for example, press the [VOICE SELECT] button (its indicator will light). The number shown on the MULTI DISPLAY will be the current value of the selected parameter.

## 2 Edit the Parameter

The PSR-410 lets you edit parameters using three different methods. Use the one that best suits the parameter you have selected:

### 2-1: The Function Button

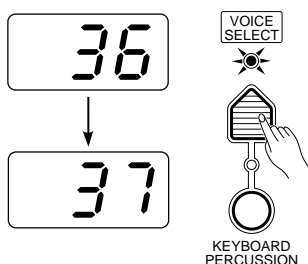

Each time you press a function button (except for the SPLIT POINT button) after initially selecting the function, the value of the corresponding parameter will be incremented (increased) by one. If you hold the function button for a few seconds, the parameter will begin to increment continuously as long as you hold the button.

If, for example, you press the [VOICE SELECT] button and MULTI DISPLAY shows that voice number 36 is currently selected, you can select voice number 37 simply by pressing the [VOICE SELECT] button again.

## 2-2: The [+] and [-] Buttons

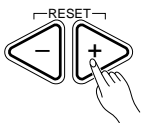

The [+] and [-] buttons immediately to the right of the MULTI DISPLAY can be used to increment (increase by one) or decrement (decrease by one) the currently selected parameter. Press the [+] button briefly to increment the parameter value, or the [-] button to decrement. If you hold the [+] or [-] button down, the value will increment or decrement continuously — simply release the button when the desired value has been reached.

## 2-3: The Number Buttons

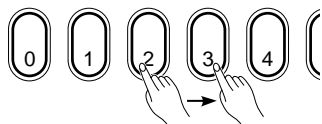

The number buttons — to the right of the [+] and [-] buttons — allow direct numeric entry of the desired value, and are therefore the fastest way to edit in many situations.

To select a voice, for example, choose one of the 128 voices — numbered “01” through “128” — shown on the panel VOICE list, then enter its number using the number buttons. To select “HARMONICA” (number 23), for example, first press [2] then [3]. The number “23” should then appear on the MULTI DISPLAY.



The [+/-] button is used to switch between positive and negative values with parameters that allow negative values (Transpose, Tuning, Octave, and Pan, for example). A “-” appears before negative values on the MULTI DISPLAY.

When selecting voice numbers the [+/-] button is used to enter the hundreds digit of the voice number (the button alternately selects no hundreds digit or “1”), as required, prior to entering the tens and ones digits. The [1] number button cannot be used to enter the hundreds digit when selecting voices.

Values outside the range of the selected parameter can not be entered.



- After editing a parameter other than [VOICE SELECT], the [VOICE SELECT] parameter will automatically be re-selected after a brief delay.
- If you attempt to change a parameter that can not be edited in the current mode, “---” will appear on the MULTI DISPLAY.

### ● Yes/No Confirmation



Some operations that change important settings or erase data may require you to confirm your choice by pressing the [YES] or [NO] button. When a choice needs to be confirmed the ARE YOU SURE? indicator will flash and a digitally sampled voice will ask “Are you sure?”. Press the [YES] button to execute the specified operation or the [NO] button to cancel and leave the settings or data unaffected.

If you don’t want to hear the “Are you sure?” confirmation sound, hold down the [NO] button while initially turning the power switch on. To restore the confirmation sound, turn the power switch off, then turn it back on again while holding down the [YES] button. The on/off status of the confirmation sound is retained in memory even when the power switch is turned off as long as batteries are installed on an AC adaptor is connected.

# Selecting & Playing the Voices

The PSR-410 has 128 stunning voices plus 8 different drum and percussion kits that you can select and play in a number of ways.

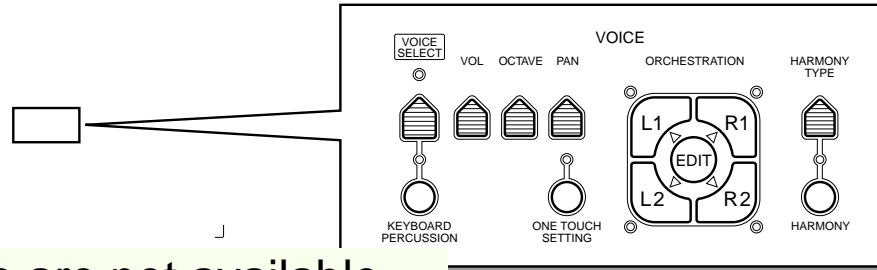

The illustrations here are not available.

## Orchestration

The unique ORCHESTRATION button group in the PSR-410's VOICE control section lets you select and play from one to four "parts" at the same time using a variety of "orchestrations". One of the PSR-410's 128 voices is assigned to each part.

- **Single:** One voice over the entire keyboard.
- **Dual:** Two voices simultaneously over the entire keyboard.
- **Split:** Different voices with the left and right hands.
- **Split & Dual:** Combinations of the Split and Dual modes.

There are actually a number of variations on each of the above orchestrations. The ORCHESTRATION buttons are used to choose the type of orchestration you want.

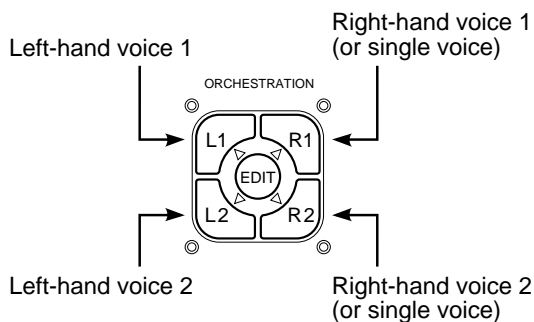

The four available parts are turned on and off by the [R1], [R2], [L1], and [L2] buttons. The indicators next to each of these buttons tell you which parts are on and which are off, and therefore indicate the current orchestration mode. The [EDIT] button determines which of the four orchestration parts is to be edited. You can, for example, assign any of the PSR-410's 128 voices to each of the orchestration parts. But before we discuss voice assignment and editing, let's take a look at the various orchestration modes:

### Single Modes

In the "single" modes either the [R1] or [R2] part voice can be played over the entire keyboard. The R1 and R2 single-voice modes are selected simply by pressing either the [R1] or [R2] button if neither the [L1] or [L2] indicators are lit. If the [L1] and/or [L2] indicators are lit, press them so that both indicators go out.

Note that when you select the [R1] or [R2] single-voice mode, the triangular EDIT indicator for the selected voice also lights. This means you can select a different voice number or otherwise edit the current voice using the procedures described on page 12.

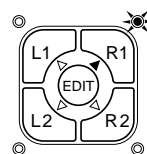

The R1 voice is played across the entire keyboard.

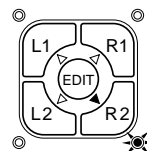

The R2 voice is played across the entire keyboard.

## ● Dual Mode

In the dual mode both the **[R1]** and **[R2]** part voices are selected so they can be played simultaneously across the entire keyboard. To select the dual mode, make sure that both the **[L1]** and **[L2]** indicators are out, then press both the **[R1]** and **[R2]** buttons simultaneously (or hold one while pressing the other).

You can switch back to either of the single modes from the dual mode simply by pressing the **[R1]** or **[R2]** button, as required.

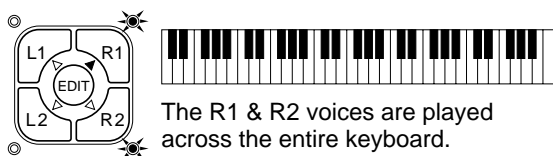

## ● Split Modes

The PSR-410 allows four different split modes, with one voice played on the left-hand section of the keyboard (**[L1]** or **[L2]**) and a different voice on the right-hand section of the keyboard (**[R1]** or **[R2]**). Selecting a split mode is simply a matter of pressing the buttons corresponding to the desired left- and right-hand parts.

The split point (i.e. the key at which the voices change over) can be set at any desired key by using the SPLIT POINT CHANGE function described on page 18.

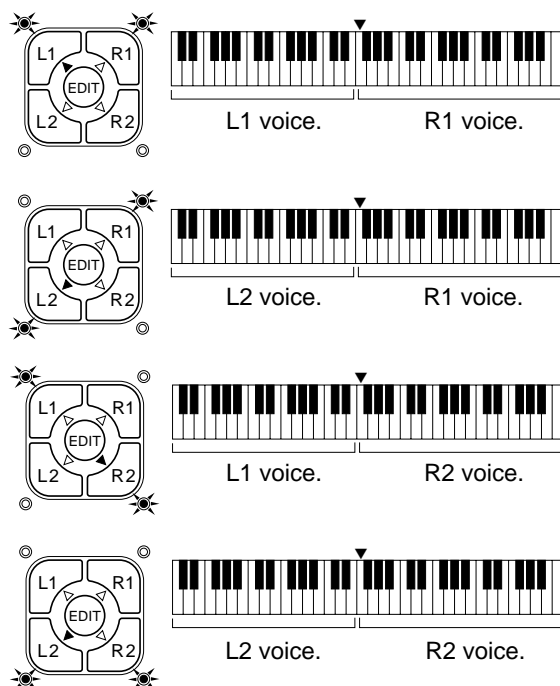

## ● Split & Dual Modes

There are five possible combinations of the split and dual modes, as shown below. The part for the single-voice side of the combination is selected simply by pressing the appropriate part button, while for the dual-voice side both buttons must be pressed simultaneously (or one while holding the other).

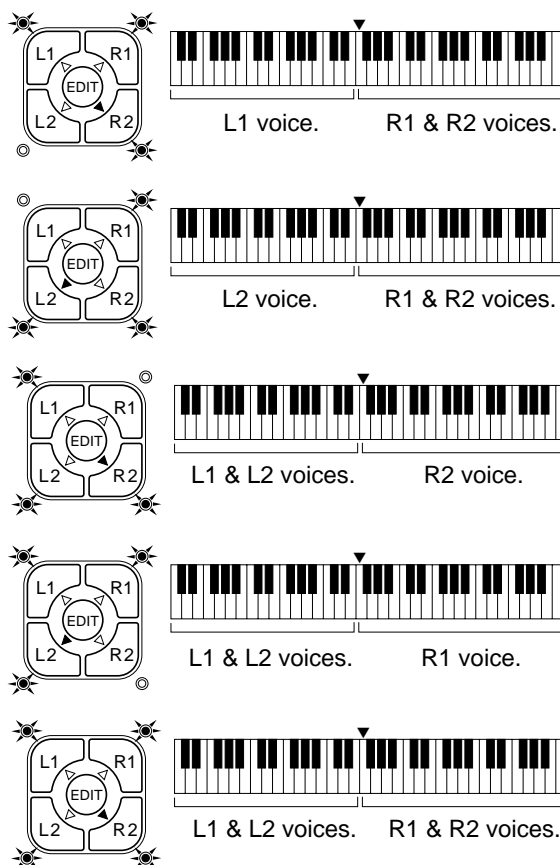

# Selecting & Playing the Voices

## Voice Assignment

You can assign any of the PSR-410's 128 voices to each of the ORCHESTRATION parts, whether the part is currently ON or OFF.

### 1 Press the [VOICE SELECT] Button .....

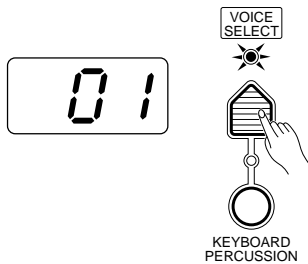

You don't need to do this if the [VOICE SELECT] indicator is already lit. Also make sure that the [KEYBOARD PERCUSSION] indicator is out.

### 2 Select the Part You Want to Edit .....



Use the ORCHESTRATION [EDIT] button to select the part to which you want to assign a new voice. The [EDIT] indicators light in sequence in the clockwise direction each time the [EDIT] button is pressed.



- You can edit the voice number of a part that is OFF while playing a different part.
- Actually, the [VOICE SELECT] mode is automatically selected whenever the [EDIT] button is pressed, so you don't really need to press [VOICE SELECT] as described in step 1 if you're going to use the [EDIT] button prior to selecting a voice number.

### 3 Select a Voice Number .....

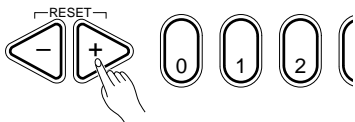

Referring to the VOICE list printed on the PSR-410 panel, use the [+] and [-] buttons, the number buttons, or the [VOICE SELECT] button itself to select the required voice number (see page 8 for editing procedure details).

**Example:** Voice number "120"

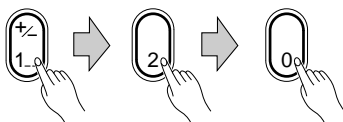

When entering voice numbers higher than 99, use the [+/-] button to enter the hundreds digit prior to entering the tens and ones digits: the button alternately selects no hundreds digit or "1".



- The optimum keyboard range is preset for each voice.

## Volume

You can individually set the volume of each orchestration part to set up the ideal balance between parts.

### 1 Select the Part You Want to Edit .....

Use the ORCHESTRATION [EDIT] button to select the part you want to edit.

### 2 Press the [VOL] Button .....

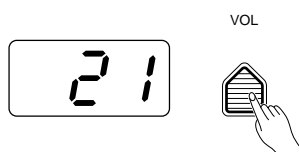

Press the VOICE control section [VOL] button. The current volume value of the selected part will appear on the MULTI DISPLAY.

### 3 Set the Volume .....

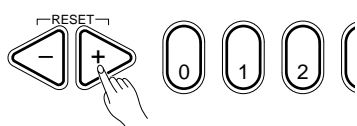

Use the [+] and [-] buttons, the number buttons, or the [VOL] button itself to set the desired volume. The volume range is from **00** (no sound) to **24** (maximum volume). The default volume value (21) can be recalled instantly by pressing both the [+] and [-] buttons at the same time.

## Octave

You can individually shift the octave of each orchestration part up or down by up to two octaves. This makes it easy, for example, to lower the pitch of a bass voice to an appropriate octave without affecting the other parts in your orchestration.

### 1 Select the Part You Want to Edit .....

Use the ORCHESTRATION [EDIT] button to select the part you want to edit.

### 2 Press the [OCTAVE] Button .....

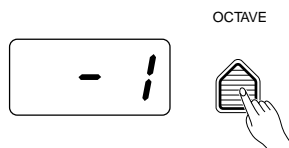

Press the VOICE control section [OCTAVE] button. The current octave value of the selected part will appear on the MULTI DISPLAY.

### 3 Set the Octave .....

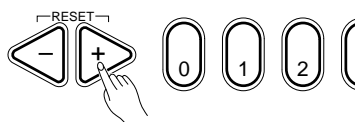

Use the [+] and [-] buttons, the number buttons, or the [OCTAVE] button itself to set the desired octave. The octave range is from **-2** (down two octaves) to **+2** (up two octaves). The normal octave value for the selected voice can be recalled instantly by pressing both the [+] and [-] buttons at the same time.

# Selecting & Playing the Voices

## ■ Pan

The PSR-410 delivers true stereo sound, and you can use this parameter to individually set the stereo (pan) position of each orchestration part to create a broad stereo image of your sound.

### 1 Select the Part You Want to Edit .....

Use the ORCHESTRATION [EDIT] button to select the part you want to edit.

### 2 Press the [PAN] Button .....

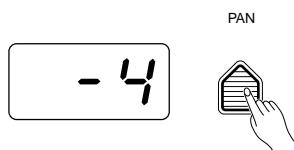

Press the VOICE control section [PAN] button. The current pan value of the selected part will appear on the MULTI DISPLAY.

### 3 Set the Pan Position .....

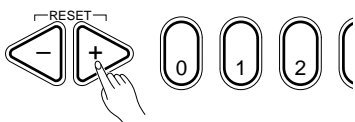

Use the [+] and [-] buttons, the number buttons, or the [PAN] button itself to set the desired pan value. The pan range is from -7 (full left) to +7 (full right). A setting of "0" places the sound of the selected part in the center of the stereo sound field. Other settings produce in-between positions. "-4", for example, would place the sound between center and full left.

The center pan position (0) can be recalled instantly by pressing both the [+] and [-] buttons at the same time.



• The new pan value will apply from the next note played — i.e. you can't pan the sound of a note while it is playing.

## ■ Auto Harmony

Auto Harmony is used with the PSR-410's Auto Accompaniment feature except for Full fingering mode (see page 20). It automatically adds appropriate harmony notes to a single-note melody line you play on the keyboard. You can choose from 10 different types of harmony that can be assigned to the right-hand orchestration parts.

### 1 Turn Auto Harmony ON

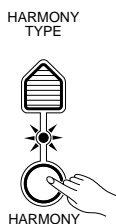

Press the **[HARMONY]** button so that its indicator lights. This turns Auto Harmony ON.



- The HARMONY can't be engaged when Keyboard Percussion is ON.

### 2 Press the [HARMONY TYPE] Button

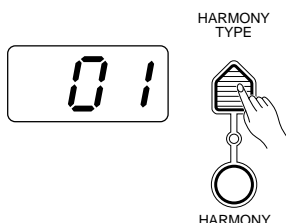

Press the VOICE control section **[HARMONY TYPE]** button. The number of the currently selected harmony type will appear on the MULTI DISPLAY.

### 3 Select a Harmony Type

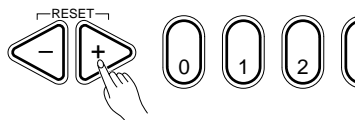

Use the **[+]** and **[-]** buttons, the number buttons, or the **[HARMONY TYPE]** button itself to select the desired effect.

#### The Harmony Types

01	Duet	06	4-way close 1
02	1 + 5	07	4-way close 2
03	Country	08	4-way open
04	Trio	09	Octave
05	Block	10	Strum

### 4 Turn Auto Harmony ON or OFF as Required

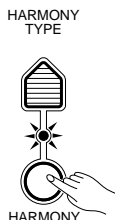

Use the **[HARMONY]** button to turn Auto Harmony ON or OFF. Auto Harmony is ON when the **[HARMONY]** button indicator is lit.



- When Auto Harmony is used in the dual mode, the R1 voice responds to notes played on the keyboard while the harmony notes are played by the R1 and R2 voices, depending on the selected harmony type.
- Only a single note can be played at a time on the keyboard (or the right-hand section of the keyboard) when the Auto Harmony feature is used.
- If you play more than one note at the same time while Auto Harmony is ON, only the highest note will sound.
- Auto Harmony will only function when the Auto Accompaniment function is being used (page 20).

# Selecting & Playing the Voices

## Keyboard Percussion

The PSR-410 has 8 different drum and percussion “kits” that can be played on the keyboard when the Keyboard Percussion function is turned ON. The types of drum and percussion instruments played by the various keys when Keyboard Percussion function is selected are marked by symbols above the keys.

### 1 Turn Keyboard Percussion ON

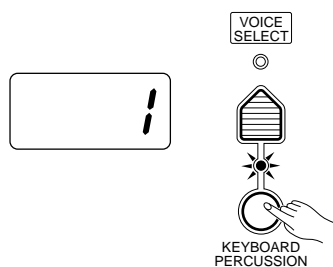

Press the [**KEYBOARD PERCUSSION**] button so that its indicator lights to turn Keyboard Percussion ON. The percussion kit number will appear on the MULTI DISPLAY.

### 2 Select a Percussion Kit

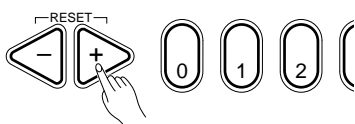

Use the [+ ] and [- ] buttons, the number buttons, or the [**VOICE SELECT**] button to select the desired percussion kit (1 through 8). See page 218 for a complete list of the percussion kit instruments.

#### The Percussion Kits

1	Standard
2	Room
3	Rock
4	Electronic
5	Analog
6	Jazz
7	Brush
8	Classic

#### NOTES

- The *HARMONY* and *TRANSPOSE* functions (pages 15 and 19) do not affect the percussion sounds. The *HARMONY* function will be canceled when Keyboard Percussion is turned ON.
- The *ORCHESTRATION [EDIT]* button does not function when Keyboard Percussion is turned ON.

## ■ Pitch Bend

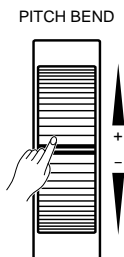

The **PITCH BEND** wheel to the left of the keyboard allows the note pitch to be bent up or down — roll the wheel away from you to bend up, and toward you to bend down (this situation can be reversed, as described below). When the **PITCH BEND** wheel is moved almost all the way in either direction, the current pitch bend range value will appear on the **MULTI DISPLAY** (see below).

### ● Setting the Pitch Bend Range

The maximum amount of pitch bend produced by the **PITCH BEND** wheel can be set anywhere from  $\pm 1$  semitone to  $\pm 12$  semitones (i.e. plus or minus one octave).

#### 1 Call the Pitch Bend Range Parameter .....

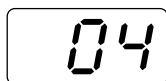
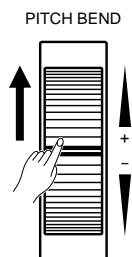

To set the pitch bend range, roll the **PITCH BEND** wheel all the way in either direction so that the current range value appears on the **MULTI DISPLAY**.

#### 2 Set the Pitch Bend Range .....

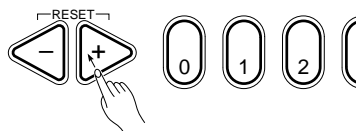

While holding the **PITCH BEND** wheel at its maximum position, use the [+ ] and [- ] buttons or the number buttons to select the desired pitch bend range. The pitch bend range value is displayed in semitones (**-12** through **12**). If a minus setting is selected pitch bend wheel operation is reversed — i.e. roll the wheel away from you to lower pitch. The default pitch bend range (02) can be instantly recalled by pressing [+ ] and [- ] buttons simultaneously.

#### 3 Release the PITCH BEND Wheel .....

Release the **PITCH BEND** wheel when you've set the required pitch bend range.

## ■ Sustain

SUSTAIN PEDAL

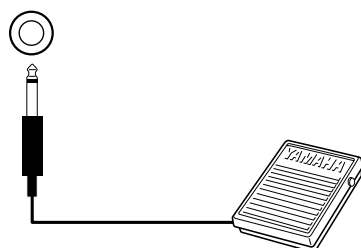

If you have plugged an optional Yamaha FC4 or FC5 footswitch into the PSR-410's rear-panel **SUSTAIN PEDAL** jack, the footswitch can be used as a damper pedal, controlling sustain. Press the pedal to sustain notes after the keys are released.

# Overall Control

The OVERALL CONTROL section includes a range of parameters that, as their title suggests, apply to the overall sound of the PSR-410.

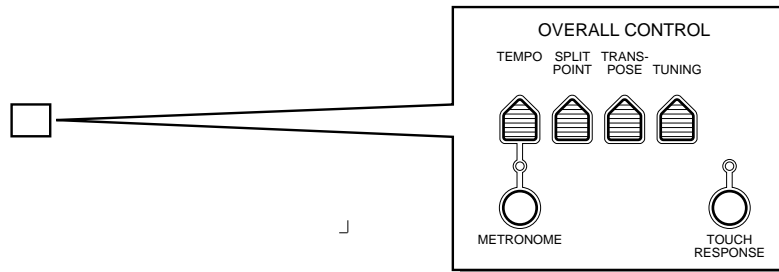

The illustrations here are not available.

## Split Point Change

This function lets you set the split point (the key that separates the left-hand and right-hand orchestration parts) to any key on the keyboard.

### 1 Turn Auto Accompaniment OFF

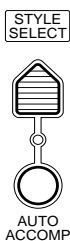

To set the split point for the left- and right-hand orchestration parts, make sure that the [AUTO ACCOMP] indicator is off before proceeding.



- The PSR-410 actually memorizes two separate split points: one for the left- and right-hand orchestration parts, and one for Auto Accompaniment mode. See page 21 for details on setting the Auto Accompaniment split point.

### 2 Press the [SPLIT POINT] Button



Press the OVERALL CONTROL section [SPLIT POINT] button. The key number of the current split point will appear on the MULTI DISPLAY.



- The key numbers for each note are listed above the keyboard. The C3 (middle C) key number, for example, is 60.

### 3 Set the Split Point

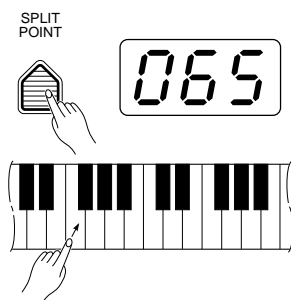

The easiest way to set the split point is to press the key you want to set as the split point while holding the [SPLIT POINT] button. The number of the selected key will appear on the MULTI DISPLAY.

As with all other parameters, you can also use the [+] and [-] buttons or the number buttons to select the desired split point. The default split point (69) can be recalled instantly by pressing both the [+] and [-] buttons at the same time.



- The split-point key becomes the lowest key in the right-hand section of the keyboard.

## Transpose

The PSR-410 [TRANPOSE] button makes it possible to shift the pitch of the PSR-410 up or down in semitone intervals up to a maximum of 12 semitones (one octave). Transposing the pitch of the PSR-410 keyboard makes it easier to play in difficult key signatures, and you can easily match the pitch of the keyboard to the range of a singer or other instrumentalist.

### 1 Press the [TRANPOSE] Button .....

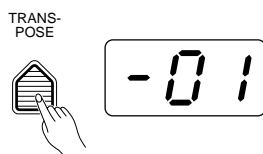

Press the OVERALL CONTROL section [TRANPOSE] button. The current transpose value will appear on the MULTI DISPLAY.

### 2 Set the Desired Degree of Transposition .....

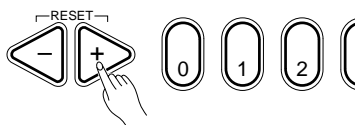

Use the [+] and [-] buttons, the number buttons, or the [TRANPOSE] button itself to set the desired degree of transposition.

The transposition range is from **-12** to **+12**, with **-12** corresponding to downward transposition by 12 semitones (one octave), and **+12** corresponding to upward transposition by 12 semitones. **00** is the “normal” keyboard pitch value. The normal transpose value (**00**) can be recalled instantly by pressing both the [+] and [-] buttons at the same time.



• The new transpose value will apply from the next note played — i.e. you can't transpose the sound of a note while it is playing.

## Tuning

The PSR-410 [TUNING] button makes it possible to tune the pitch of the PSR-410 to match other instruments. Tuning can be accomplished over a  $\pm 50$ -cent range (that's 100 cents total, or one semitone) in 33 steps.

### 1 Press the [TUNING] Button .....

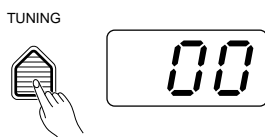

Press the OVERALL CONTROL section [TUNING] button. The current tuning value will appear on the MULTI DISPLAY.

### 2 Set the Tuning .....

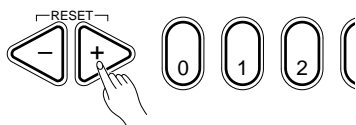

Use the [+] and [-] buttons, the number buttons, or the [TUNING] button itself to set the desired tuning value.

The tuning range is from **-16** (-50 cents) to **+16** (+50 cents). “**00**” ( $\pm 0$  cents) is the “normal” tuning value. The normal tuning value (**00**) can be recalled instantly by pressing both the [+] and [-] buttons at the same time.



• The tuning setting is retained in memory even when the power switch is turned off, as long as batteries are installed or an AC adaptor is connected.

## Touch Response

This function turns the touch response of the keyboard on or off.



Use the [TOUCH RESPONSE] button to turn touch response ON or OFF as required. When OFF (i.e. when the indicator is off) the same volume is produced no matter how hard you play on the keyboard. Touch response can be turned OFF to produce a more realistic effect with voices that normally do not have touch response: e.g. organ and harpsichord.

# Auto Accompaniment

The PSR-410 has 80 accompaniment styles that can be used to provide fully-orchestrated Auto Accompaniment.

When the Auto Accompaniment function is turned ON, the PSR-410 creates fully-orchestrated rhythm, bass, and chord accompaniment based on chords you play with the left hand in the Auto Accompaniment section of the keyboard (i.e. all keys to the left of the Auto Accompaniment split point). The right-hand section of the keyboard is available for normal playing.

The default Auto Accompaniment split point is the G2 (55) key. The Auto Accompaniment section of the keyboard consists of all keys to its left. The Auto Accompaniment split point can be set to any other key as described in "Setting the Auto Accompaniment Split Point" on page 21.

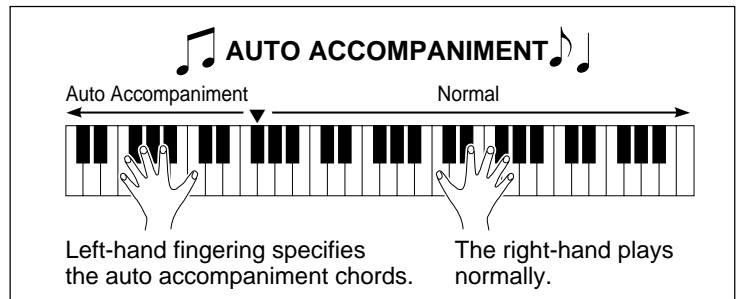

## NOTES

- The PSR-410 also has a special "Full" Auto Accompaniment fingering mode in which chords played anywhere on the keyboard determine the Auto Accompaniment chords. See page 24 for details.

The illustrations here are not available.

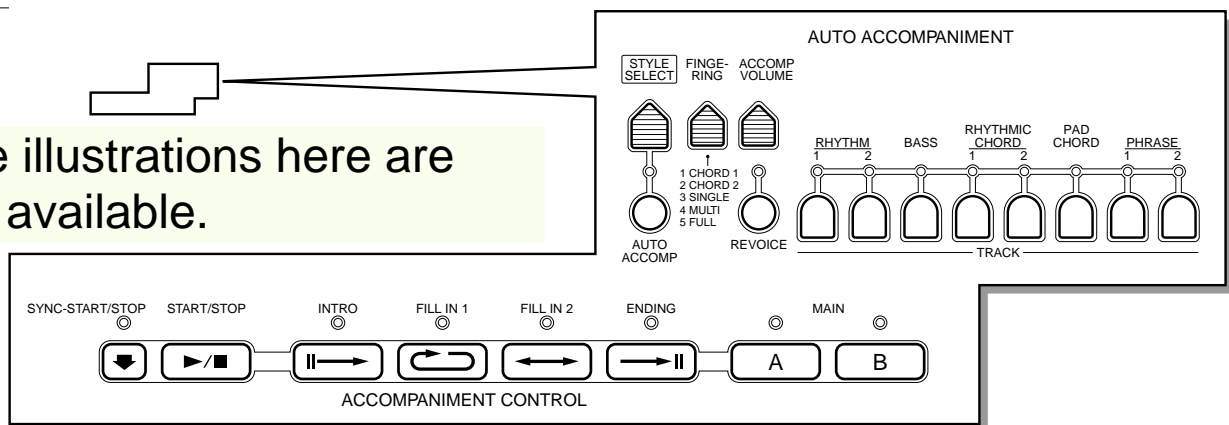

## Selecting a Style

Any of the PSR-410's 80 accompaniment styles can be selected via the normal editing procedure. This can be done either before or during accompaniment playback. See page 49 for descriptions of all 80 styles.

### 1 Press the [STYLE SELECT] Button

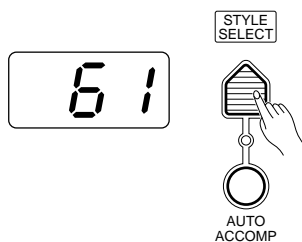

When you press the [STYLE SELECT] button the currently selected style number will appear on the MULTI DISPLAY.

### 2 Select a Style Number

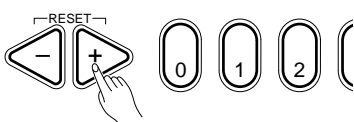

Referring to the STYLE list printed on the PSR-410 panel, use the [+] and [-] buttons, the number buttons, or the [STYLE SELECT] button itself to select the required style number (see page 8 for editing procedure details).

## ■ Setting the Auto Accompaniment Split Point

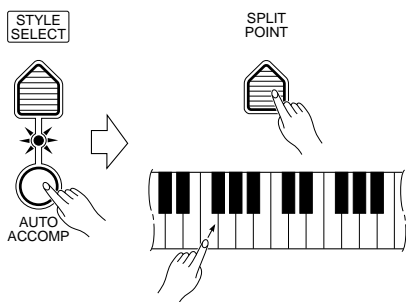

To set the Auto Accompaniment split point, first turn Auto Accompaniment ON — press the [AUTO ACCOMP] button so that its indicator lights — then proceed with steps 2 and 3 as described in “Split Point Change” on page 18. The default Auto Accompaniment split point (55) can be recalled instantly by pressing both the [+] and [-] buttons at the same time.

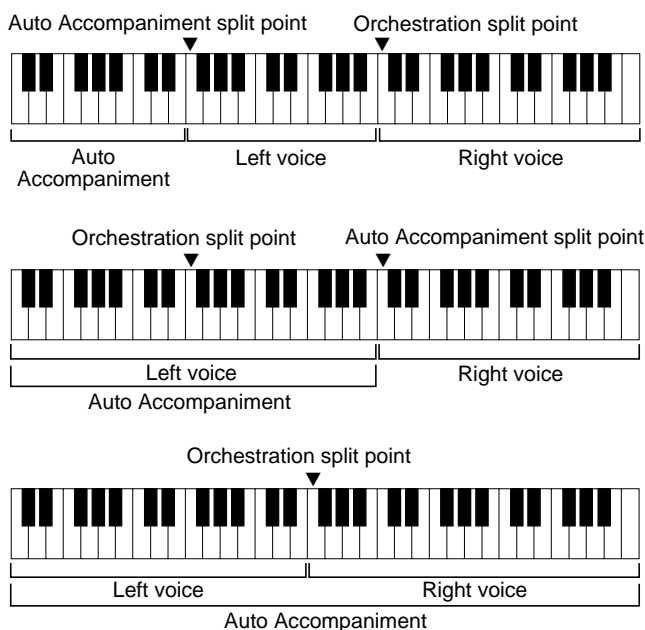

### NOTES

- If the Auto Accompaniment split point is set at a lower key than the orchestration split point, the L1 and/or L2 voice will sound between the Auto Accompaniment and orchestration split points.
- If the Auto Accompaniment split point is set at a higher key than the orchestration split point, the L1 and/or L2 voice will sound throughout the entire Auto Accompaniment section.
- If the Auto Accompaniment “Full” fingering mode is selected, the L1 and/or L2 voice will sound to the left of the orchestration split point while the R1 and/or R2 voice will sound to the right of the orchestration split point.

## ■ Auto Accompaniment Fingering

The PSR-410 has 5 Auto Accompaniment fingering modes, selected via the [FINGERING] button.

### 1 Press the [FINGERING] Button

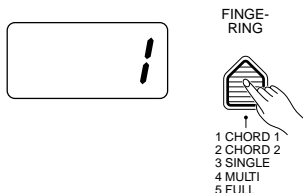

When you press the [FINGERING] button the currently selected Auto Accompaniment fingering number will appear on the MULTI DISPLAY.

### 2 Select a Fingering Mode

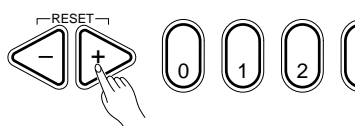

Use the [-] and [+] buttons, the number buttons, or the [FINGERING] button itself to select the required fingering mode (see page 8 for editing procedure details).

# Auto Accompaniment

## ● Mode 1: Chord 1

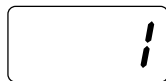

The Chord 1 mode is ideal if you already know how to play chords on a keyboard, since it allows you to supply your own chords for the Auto Accompaniment feature.

The PSR-410 will accept the following chord types:

### Example for “C” chords

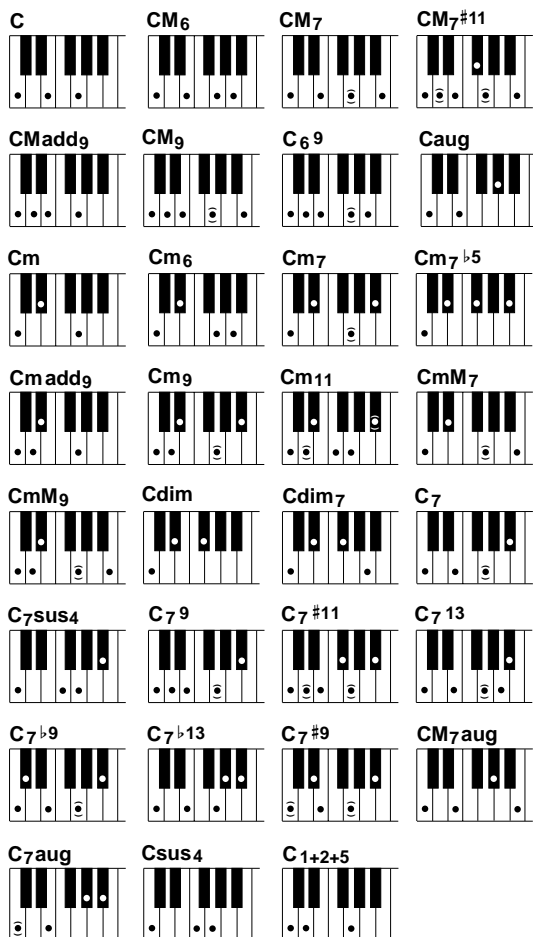

Major [M]	.....	1 - 3 - 5
Major sixth [M6]	.....	1 - 3 - 5 - 6
Major seventh [M7]	.....	1 - 3 - (5) - 7
Major seventh sharp eleventh [M7#11]	..	1 - (2) - 3 - #4 - (5) - 7
Major add ninth [Madd9]	.....	1 - 2 - 3 - 5
Major ninth [M9]	.....	1 - 2 - 3 - (5) - 7
Major sixth add ninth [6 9]	.....	1 - 2 - 3 - (5) - 6
Augmented [aug]	.....	1 - 3 - #5
Minor [m]	.....	1 - b3 - 5
Minor sixth [m6]	.....	1 - b3 - 5 - 6
Minor seventh [m7]	.....	1 - b3 - (5) - b7
Minor seventh flatted fifth [m7b5]	.....	1 - b3 - b5 - b7
Minor add ninth [madd9]	.....	1 - 2 - b3 - 5
Minor ninth [m9]	.....	1 - 2 - b3 - (5) - b7
Minor eleventh [m11]	.....	1 - (2) - b3 - 4 - 5 - (b7)
Minor major seventh [mM7]	.....	1 - b3 - (5) - 7
Minor major ninth [mM9]	.....	1 - 2 - b3 - (5) - 7
Diminished [dim]	.....	1 - b3 - b5
Diminished seventh [dim7]	.....	1 - b3 - b5 - 6
Seventh [7]	.....	1 - 3 - (5) - b7
Seventh suspended fourth [7sus4]	.....	1 - 4 - 5 - b7
Seventh ninth [7 9]	.....	1 - 2 - 3 - (5) - b7
Seventh sharp eleventh [7#11]	.....	1 - (2) - 3 - #4 - (5) - b7
Seventh thirteenth [7 13]	.....	1 - 3 - (5) - 6 - b7 or 2 - 3 - 5 - 6 - b7
Seventh flatted ninth [7b9]	.....	1 - b2 - 3 - (5) - b7
Seventh flatted thirteenth [7b13]	.....	1 - 3 - 5 - b6 - b7
Seventh sharp ninth [7#9]	.....	(1) - #2 - 3 - (5) - b7
Major seventh augmented [M7aug]	.....	1 - 3 - #5 - 7
Seventh augmented [7aug]	.....	(1) - 3 - #5 - b7
Suspended fourth [sus4]	.....	1 - 4 - 5
One plus two plus five [1+2+5]	.....	1 - 2 - 5

### NOTES

- Notes in parentheses can be omitted.
- A perfect fifth produces accompaniment based only on the root and fifth which can be used with many major and minor chords.
- An octave produces accompaniment based only on the root.
- If three adjacent keys are played simultaneously (white and black keys), chord accompaniment will be cancelled and only the rhythm accompaniment will sound. (Chord 1/Chord 2 mode)
- The chord fingerings listed are all in “root position”, but other inversions can be used — with the following exceptions:
  - \* M6 chords are only recognized in root position. All other inversions are interpreted as m7.
  - \* 6 9 chords are only recognized in root position. All other inversions are interpreted as m11.

- \* m6 chords are only recognized in root position. All other inversions are interpreted as m7b5.
- \* 1+2+5 chords are only recognized in root position. All other inversions are interpreted as sus4.
- \* With aug and dim7 chords the lowest note played is assumed to be the root.
- \* With 7#11 chords the lowest note played is assumed to be the root or b7.

● **Mode 2: Chord 2**

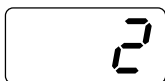

This is essentially the same as the Chord 1 mode, above, except that the lowest note played in the Auto Accompaniment section of the keyboard will be played by the bass part rather than the chord root.



● **Mode 3: Single**



SINGLE mode fingering makes it simple to produce beautifully orchestrated accompaniment using major, seventh, minor and minor-seventh chords by pressing a minimum number of keys in the Auto Accompaniment section of the keyboard. The accompaniment produced is perfectly matched to the currently selected accompaniment style.



**Major Chords:**

If you press a “C” key in the left-hand section of the keyboard, for example, a C-major accompaniment will be played. Press another key in the left-hand section of the keyboard to select a new chord. The key you press will always determine the “root” of the chord played (i.e. “C” for a C chord).

**Minor Chords:**

Simultaneously press the root key and a black key to its left.

**Seventh Chords:**

Simultaneously press the root key and a white key to its left.

**Minor-seventh Chords:**

Simultaneously press the root key and both a white and black key to its left.



- The Auto Accompaniment will continue playing even if you lift your fingers from the Auto Accompaniment keys. You only need to press the Auto Accompaniment keys when changing chords.

● **Mode 4: Multi**

This is a combination of the Single and Chord 1 modes. In this mode the PSR-410 automatically discriminates between Single and Chord 1 mode fingerings and generates the appropriate accompaniment.



- If more than two keys are played and all but the highest key are black keys, and the chord is not recognized by the Chord 1 mode, the highest note will be interpreted as the root of a minor (m) chord.
- If more than three keys are played and, excluding the highest key, are a mixture of black and white keys, and the chord is not recognized by the Chord 1 mode, the highest note will be interpreted as the root of a minor-seventh (m7) chord.
- If more than two keys are played and all but the highest key are white keys, and the chord is not recognized by the Chord 1 mode, the highest note will be interpreted as the root of a seventh (7) chord.

# Auto Accompaniment

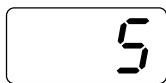

## ● Mode 5: Full

In this mode chords played anywhere on the keyboard are detected and used for Auto Accompaniment. Otherwise the keyboard functions normally, and the entire range is available for playing. Chord recognition is the same as in the Chord 1 mode. Please note that in this mode all notes you play on the keyboard at any one time will be interpreted as the Auto Accompani-



- A single note one octave lower than the lowest note of the chord is recognized as a bass note, and a single note eleven notes upper is recognized as a melody note.

## Stop Accompaniment

### function

Chords played in the Auto Accompaniment section of the keyboard are also detected and played by the PSR-410 Auto Accompaniment system when the accompaniment is stopped (except for Full fingering mode). In this case the bass note and chord voices are selected automatically.

## ■ Tempo Control

The [TEMPO] button can be used to control the tempo of AUTO ACCOMPANIMENT, SONG MEMORY, and MULTI PAD playback (see pages 36 and 37 respectively).

### 1 Press the [TEMPO] Button.....

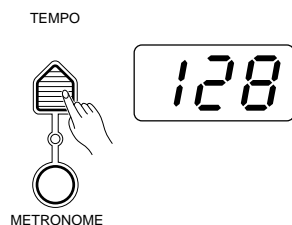

Press the OVERALL CONTROL section [TEMPO] button. The current tempo (beats per minute) will appear on the MULTI DISPLAY.

### 2 Set the Tempo.....

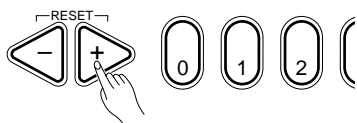

Use the [+] and [-] buttons, the number buttons, or the [TEMPO] button itself to set the desired tempo.

The available tempo range is from **040** to **240** beats per minute. Each accompaniment style has a different “default” tempo which is automatically set whenever a new style is selected (but not when a new style is selected while the accompaniment is playing). The default tempo for the currently selected accompaniment style can be recalled instantly by pressing both the [+] and [-] buttons at the same time.

## ● The [METRONOME] Button

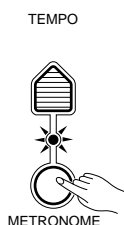

The PSR-410 includes a metronome function that you’ll use primarily with the recording functions described on page 32. If you press the [METRONOME] button so that its indicator lights when using Auto Accompaniment, the metronome will sound at the currently set tempo when the synchro-start mode is engaged, and while the accompaniment is playing.

## ■ Accompaniment Control

The PSR-410 provides a range of accompaniment “sections” — introduction, fill-ins, variations on the main pattern, ending — that you can select to control the “flow” of the accompaniment to achieve the desired musical results. Accompaniment start/stop and sections are controlled by the ACCOMPANIMENT CONTROL buttons.

### ● Straight Start



The [START/STOP] button starts the selected accompaniment style immediately.

Press the [AUTO ACCOMP] button so that its indicator lights before starting the accompaniment. The accompaniment will start with the rhythm sound only when the [START/STOP] button is pressed, then the bass and chord parts will begin playing as soon as the first note or chord is played on the Auto Accompaniment section of the keyboard.



- A different accompaniment style can be selected at any time while the accompaniment is playing. The style number on the MULTI DISPLAY will change as soon as the selection is made, but the new style will begin playback from the top of the next measure. The only exception is if you change styles while an intro is playing (see page 26), in which case the new style begins playing after the intro has finished. The tempo will not change when the new style begins playing.

#### 4/4 time

	BEAT		
1st beat	●	●	●
2nd beat	●	○	○
3rd beat	○	●	○
4th beat	○	○	●

#### 3/4 time

	BEAT		
1st beat	●	●	●
2nd beat	●	○	○
3rd beat	○	●	○

#### 6/8 time

	BEAT		
1st beat	●	●	●
2nd beat	●	○	○
3rd beat	○	●	○
4th beat	○	○	●
5th beat	○	○	●
6th beat	○	○	●

### The Beat Indicator

The three BEAT indicator dots along the top of the MULTI DISPLAY flash to indicate the tempo and beat as the accompaniment plays. All three dots flash together on the first beat of each measure, then the dots flash individually in sequence on the remaining beats. In 4/4, 3/4, and 6/8 time, for example, the beat indicator dots will flash as shown to the left.



- Each accompaniment style has a preset “normal” tempo which is automatically selected whenever the style is selected while the accompaniment is stopped. The current tempo is maintained if you select a different style during accompaniment playback (excepting the playback by One Touch settings). You can change the tempo as required by using the TEMPO function described on page 24.

### ● Synchro Start

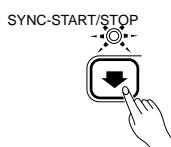

Press the [SYNC-START/STOP] button if you want the accompaniment to start when you play the first note or chord on the keyboard. In this case the accompaniment is started by playing in the left-hand section of the keyboard.



- If the AUTO ACCOMP mode is OFF, playing anywhere on the keyboard causes the rhythm-only accompaniment to start.

If you press the [SYNC-START/STOP] button, the BEAT indicator dots will flash at the current tempo. The synchro start mode can be disengaged by pressing the [SYNC-START/STOP] button again so that its indicator goes out.

# Auto Accompaniment

## ● Starting the Accompaniment with an Introduction .....

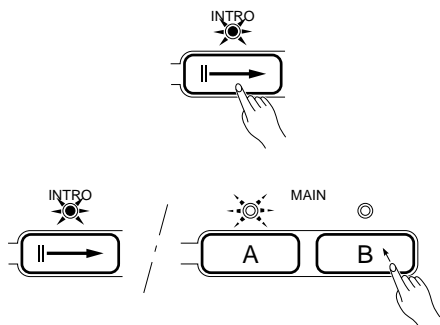

Any of the PSR-410 accompaniment patterns can be started with an appropriate introduction by pressing the [INTRO] button and then the [START/STOP] button.

Once the [INTRO] button is pressed, the [INTRO] indicator will be lit continuously and the MAIN [A] or [B] indicator will flash to indicate which section will play when the introduction has finished. You can change the “destination” section by pressing the MAIN [A] or [B] button while its indicator is flashing. When the introduction ends, the [INTRO] indicator will go out and the [A] or [B] indicator will light continuously.



- It is possible to start the accompaniment from any section — even the ending — by pressing the corresponding button prior to pressing the [START/STOP] button. The destination MAIN [A] or [B] section can be selected as described above.
- The [INTRO] button can be used to select the introduction pattern even while the accompaniment is playing.
- If you press the [SYNC-START/STOP] button and then the [INTRO] button, the accompaniment will start from the introduction as soon as a chord is detected in the Auto Accompaniment section of the keyboard.

## ● The MAIN [A] and [B] Sections .....

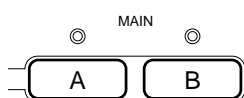

Each accompaniment style has two main sections — [A] and [B]. If the MAIN [A] or [B] button is pressed while the accompaniment is playing, the corresponding section will begin from the top of the next measure. You can also select [A] or [B] before starting the accompaniment.



- The MAIN [A] section is automatically selected whenever the power switch is turned on.

## ● Adding Fill-ins .....

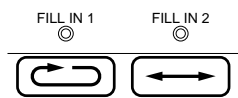

The PSR-410 provide two types of fill-ins (rhythmic variations) — one which plays and then returns to the current MAIN section, and one which leads to the other MAIN section. Press the [FILL IN 1] button at any time while the accompaniment is playing to add a one-measure fill-in and return to the current MAIN section, or press the [FILL IN 2] button to add a one-measure fill-in and go to the other MAIN section.

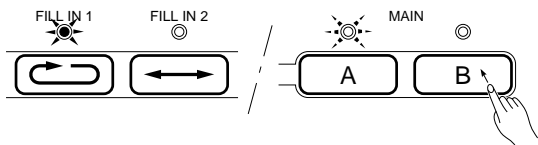

If the MAIN A section is playing, for example, the [A] indicator will flash while FILL IN 1 plays, and the [B] indicator will flash while FILL IN 2 plays. You can change the section that will begin playing after the fill-in by pressing the desired section button while the indicator is still flashing.



- If you hold the [FILL IN 1] or [FILL IN 2] button, the fill-in pattern will repeat until the button is released, then the MAIN A or B section will play from the beginning of the next measure.
- If the [FILL IN 1] or [FILL IN 2] button is pressed after the last beat of a measure, the fill-in will begin from the first beat of the next measure. If pressed at any other time the fill-in will begin immediately.
- It is also possible to start the accompaniment with a fill-in by pressing the desired FILL IN button prior to pressing the [START/STOP] button. The destination MAIN [A] or [B] section can be selected in the normal way.

## ● Stopping the Accompaniment .....

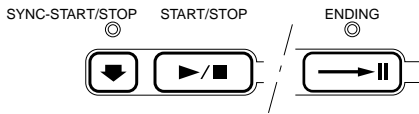

An accompaniment in progress can be stopped immediately by pressing the **[START/STOP]** button or the **[SYNC-START/STOP]** button. In the latter case the synchro start mode will be engaged when the accompaniment stops. The accompaniment can also be stopped with an appropriate ending by pressing the **[ENDING]** button.



- The ending will begin from the first beat of the next measure.
- If the **[FILL IN 1]** or **[FILL IN 2]** button is pressed while the ending pattern is playing, a fill-in will be played, followed by a return to the MAIN A or B pattern.

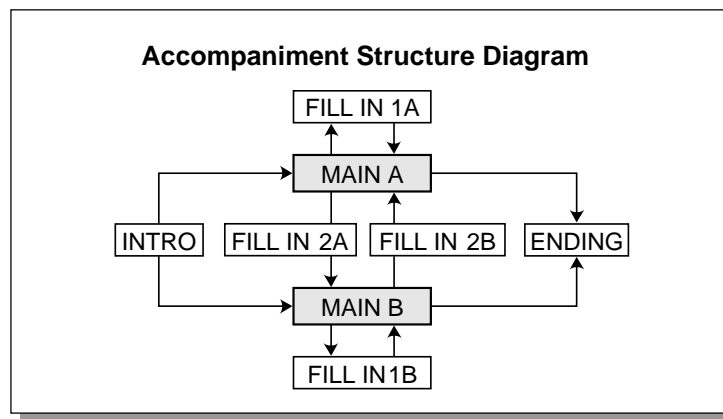

## ■ Accompaniment Volume .....

While the VOICE control section **[VOL]** button can be used to set the volume levels of the orchestration parts, the **[ACCOMP VOLUME]** button can be used to adjust the volume of the selected accompaniment in relation to the voices.

### 1 Press the **[ACCOMP VOLUME]** Button .....

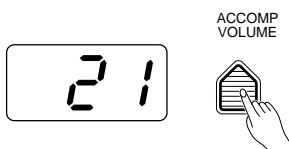

Press the AUTO ACCOMPANIMENT control section **[ACCOMP VOLUME]** button. The current accompaniment volume value will appear on the MULTI DISPLAY.

### 2 Set the Volume .....

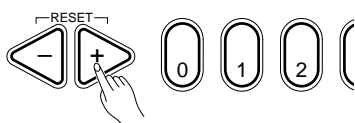

Use the **[+]** and **[-]** buttons, the number buttons, or the **[ACCOMP VOLUME]** button itself to set the desired volume. The volume range is from **00** (no sound) to **24** (maximum volume). The default volume value (21) can be recalled instantly by pressing both the **[+]** and **[-]** buttons at the same time.

# Auto Accompaniment

## ■ The Track Buttons

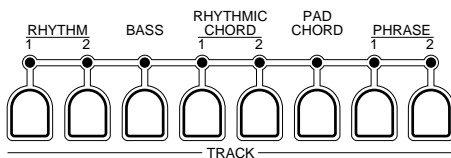

The PSR-410 Auto Accompaniment system includes eight TRACK buttons which allow you to control the accompaniment arrangement in real time. You can turn tracks on or off while playing for extra accompaniment variety.

The various tracks are turned on or off by pressing the corresponding TRACK button. When a part is turned off the corresponding indicator will go out. To silence the bass part, for example, press the TRACK [BASS] button so that its indicator goes out. Press the button again to turn that part back on.



- The indicators for all tracks that contain data in any section will light whenever an accompaniment style is selected. (Depending on the selected accompaniment style, some tracks may not contain any data.)

### ● What's In the Tracks .....

Here's how the tracks are normally used:

**RHYTHM 1:** This is the main rhythm track, and usually plays a drum kit.

**RHYTHM 2:** Additional rhythm. Turning the RHYTHM 2 track ON will usually increase the “energy” of the rhythm. In many styles this track plays percussion instruments such as congas, bongos, etc. This means you can turn off the RHYTHM 1 track and use only RHYTHM 2 for a “light” rhythm sound.

**BASS:** The BASS track always plays a bass line, but the voice will change to fit the selected style ... acoustic bass, synth bass, tuba, etc.

**RHYTHMIC CHORD 1 & 2:** Both these tracks provide the rhythmic chordal accompaniment required by each style. You'll find guitar, piano, and other chordal instruments here.

**PAD CHORD:** This track plays long chords where necessary, using sustained instruments such as strings, organ, choir.

**PHRASE 1 & 2:** This is where the musical embellishments reside. The PHRASE tracks are used for punchy brass stabs, arpeggiated chords, and other extras that make the accompaniment more interesting.

Try different combinations of tracks with each style. Some styles will sound best with the full arrangement (all tracks ON), while others might suit your needs better if a smaller arrangement is used. To “thin out” an arrangement, the PHRASE 1 and PHRASE 2 tracks are the first ones you'll want to turn OFF.

Another way to use the tracks is to gradually build up the arrangement during the course of a song. Start with a small arrangement — e.g. RHYTHM 1, BASS, and RHYTHMIC CHORD 1 — then add tracks one by one as you want to thicken the musical texture.

Some styles will actually sound quite different depending on the combination of tracks you choose. Try, for example, just RHYTHM 1, BASS, and PAD CHORD.

## ■ Re-voicing the Tracks

To make the TRACK buttons even more versatile, the PSR-410 features a REVOICE function that lets you individually change the voices and several related VOICE section parameters assigned to each track. The parameters that can be changed using the REVOICE function are as follows:

- Voice Number (Percussion Kit Number)
- Volume
- Pan
- Octave

### 1 Select a Track to Re-voice

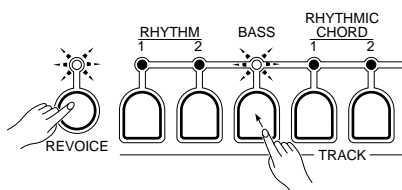

Press the TRACK button corresponding to the track you want to re-voice while holding the [REVOICE] button. Both the selected TRACK and [REVOICE] button indicators will flash. At the same time, the number of the voice currently assigned to the selected track will appear on the MULTI DISPLAY.



- At this point you can play the selected track's voice on the keyboard.
- Keyboard percussion is automatically turned on if the RHYTHM 1 or 2 track is selected.

### 2 Make the Required Voice Settings

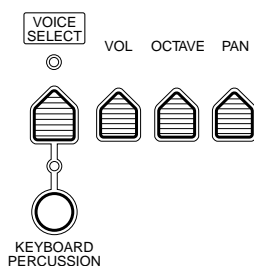

Use the [+] and [-] buttons, the number buttons, or the [VOICE SELECT] button itself to select a new voice for the selected track. You can also use the [VOL], [OCTAVE], and [PAN] buttons to change the corresponding parameters for the selected voice.



- You can use the REVOICE function either while the accompaniment is playing or stopped.
- You cannot edit the orchestration parts while the REVOICE indicator is flashing.
- You can play the keyboard and hear the re-voiced voice except for OCTAVE changes.

### 3 Repeat For All Tracks To Be Re-voiced

Repeat steps 1 and 2 to re-voice all the tracks you want to change.

### 4 Confirm the Re-voiced Data

Press the [REVOICE] button when you've finished re-voicing the desired tracks to confirm the re-voiced data. The [REVOICE] button and selected track indicators will light.

### 5 Turn REVOICE OFF to Restore the Original Voices

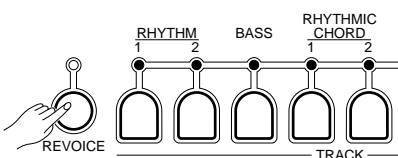

Press the [REVOICE] button so that its indicator goes out to disengage the REVOICE function when done. The re-voiced settings will be cancelled and the original voices for the selected accompaniment style will be restored.



- **ALL REVOICE settings are reset to their default values if you changes styles while the REVOICE function is OFF. If you want to keep a re-voiced setup so that it can be easily recalled later, store it in the PSR-410 REGISTRATION MEMORY, described on page 31.**
- As long as you don't change styles while the REVOICE function is OFF, the re-voiced settings are maintained and can be recalled at any time simply by turning the REVOICE function ON.
- If you change styles while the REVOICE function is engaged, the re-voiced settings will be maintained.

# One Touch Setting

Each PSR-410 accompaniment style has a suitable preset voice and other settings that can be instantly recalled by pressing the [ONE TOUCH SETTING] button in the VOICE control section. This makes it simple to recall the optimum settings for each style in one quick operation. To use the One Touch Setting function: select a style, press the [ONE TOUCH SETTING] button so that its indicator lights, then play. As long as the [ONE TOUCH SETTING] indicator is lit the ideal voice and other settings (see list below) will be automatically recalled whenever you select a new style.

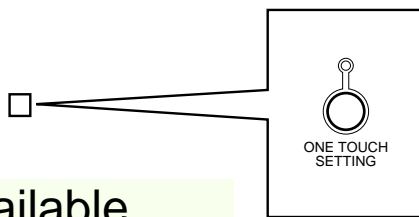

The illustrations here are not available.

The One Touch Setting function recalls the following settings:



- The preset voice settings for the currently selected style — including orchestration, voice assignments, volume, octave, pan, and harmony settings.
- The ACCOMP VOLUME level (21).
- AUTO ACCOMP is turned ON.
- The default tempo for the currently selected style.
- The track ON/OFF status for the currently selected style.
- [REVOICE] is turned OFF.
- KEYBOARD PERCUSSION is turned OFF.
- The Auto Accompaniment split point (55) is selected.
- The orchestration split point is set to 69.

You can, of course, create your original setting by editing the One Touch Setting data, and store it into the Registration Memory. (See page 31 for more information on the Registration Memory.)

Pressing the [ONE TOUCH SETTING] button again turns OFF the One Touch Setting function.



- If you press [ONE TOUCH SETTING] while rhythm-only accompaniment is playing, AUTO ACCOMP will be turned ON.
- The synchro start mode will be engaged if the [ONE TOUCH SETTING] button is turned on while the accompaniment is stopped.

# Registration Memory

The PSR-410 REGISTRATION MEMORY can be used to store four complete sets of VOICE and AUTO ACCOMPANIMENT settings that can be recalled anytime at the touch of a button. The REGISTRATION MEMORY stores the following parameters:

## VOICE

- |  |                                   |
|--|-----------------------------------|
| 1. Voice numbers for all four orchestration parts.       | 6. Harmony ON/OFF & Harmony type. |
| 2. Keyboard percussion ON/OFF & percussion kit number.   | 7. Orchestration & Edit ON/OFF.   |
| 3. Volume (all four orchestration parts and percussion). | 8. Split point.                   |
| 4. Pan (all four orchestration parts and percussion).    | 9. Touch response on/off.         |
| 5. Octave (all four orchestration parts and percussion). | 10. Pitch bend range.             |

## AUTO ACCOMPANIMENT

1. Style number.
2. Accompaniment volume.
3. Track button settings.
4. Tempo.
5. REVOICE ON/OFF and settings.
6. Split point.
7. Transpose.
8. Accomp. ON/OFF.
9. Fingering mode.

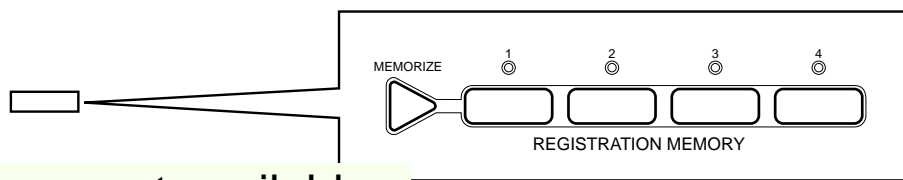

The illustrations here are not available.

### ● Memorizing the Settings .....

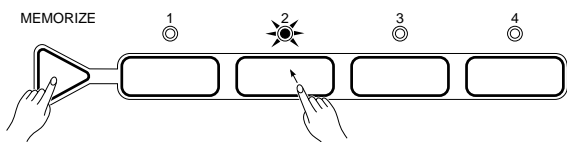

The panel settings listed above can be stored to any one of the four REGISTRATION MEMORY buttons by pressing the button — [1], [2], [3], or [4] — while holding the [MEMORIZE] button. The indicator of the selected button will light continuously indicating that the data has been stored.



- **Please note that anytime you store to a REGISTRATION MEMORY button, all settings previously stored in that button will be erased and replaced by the new settings.**
- *The indicator of the selected REGISTRATION MEMORY will flash as soon as any change is made to the panel settings. In other words, if the REGISTRATION MEMORY indicator is flashing, the current panel settings are different from those stored in the memory.*

### ● Recalling the Settings .....

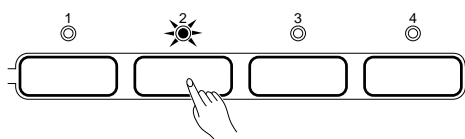

The settings stored to a REGISTRATION MEMORY button can be recalled at any time simply by pressing the appropriate button. The indicator of the selected button will light continuously when initially recalled, but will flash as soon as any change is made to the panel settings. A flashing REGISTRATION MEMORY indicator therefore indicates that the current panel settings do not correspond to those stored in the REGISTRATION MEMORY.

# Record Functions

The PSR-410 RECORDING section controls two recording functions:

- **The SONG MEMORY:**

Record complete songs including an accompaniment track and melody track. Each PAGE MEMORY holds a different song.

- **MULTI PADS:**

Record short chord, melody, or rhythm sequences that can be played back anytime by simply pressing a button. Each PAGE MEMORY holds different MULTI PAD data.

Operation of both functions is essentially the same, so once you're familiar with the basic procedure, recording songs or multi-pad phrases should be easy. We'll start with the SONG MEMORY.



• *Turning the PSR-410 power OFF during recording or record-ready mode can result in a loss of recording data.*

## Song Memory

The PSR-410 SONG MEMORY allows you to record and play back complete songs including chord sequences created using the Auto Accompaniment feature and a melody line you play on the keyboard. The SONG MEMORY has one ACCOMP track and one MELODY track.

Each PAGE MEMORY holds a different song, so the PSR-410 can retain up to 4 complete songs in memory, and these can be selected and played back simply by selecting the appropriate PAGE MEMORY.



• *Material recorded using the SONG MEMORY is retained in memory even when the POWER switch is turned OFF if batteries are present or an AC adaptor is connected (see "PAGE MEMORY" on page 41 for more details).*

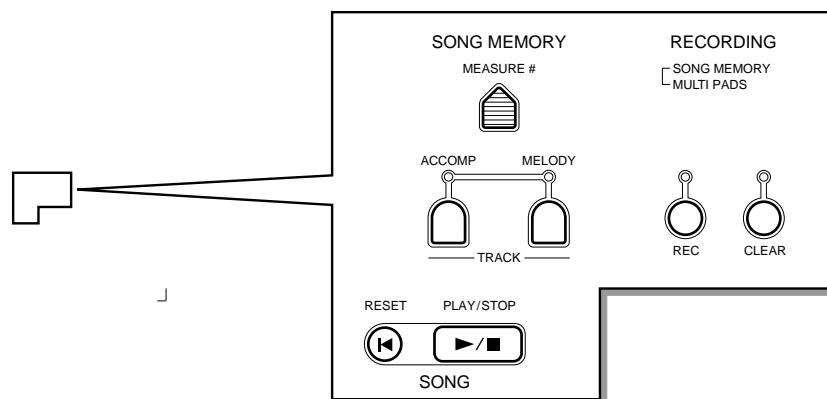

## ■ Accompaniment Track Recording

The SONG MEMORY ACCOMP track records the following operations and data:

- Chord changes.
- Intro, Main, Fill in, & Ending sections.
- Accompaniment volume.
- Auto accompaniment TRACK button operations.
- Tempo.
- Style number.
- Revoice.

### 1 Select a PAGE MEMORY

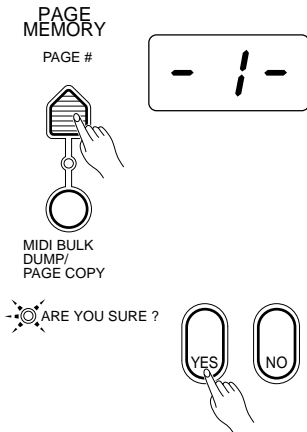

If necessary, press the [PAGE #] button to select the PAGE MEMORY number to which you want to record. When a new PAGE MEMORY number is selected the ARE YOU SURE? indicator will flash and the “Are you sure?” prompt will sound. Press the [YES] button to select the specified page number or the [NO] button to cancel (see page 41 for more details).



- After the “Are you sure?” prompt, the PortaTone will wait until you press [YES] or [NO].

### 2 Select a Style

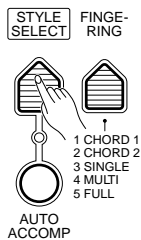

Select an accompaniment style that is appropriate for the type of music you want to record. Also select the fingering mode you want to use, if necessary.

### 3 Engage the Accompaniment Track Record Ready Mode

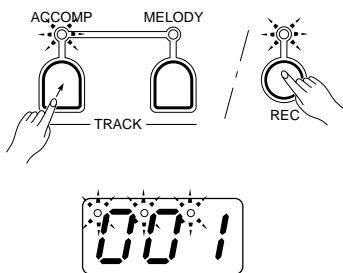

Press the SONG MEMORY section [ACCOMP] track button while holding the RECORDING section [REC] button. This engages the record ready mode for the accompaniment track. If [AUTO ACCOMP] is not already turned on, it will be automatically engaged. The [REC], [ACCOMP], and [SYNC-START/STOP] button indicators will flash, and the MULTI DISPLAY BEAT indicator dots will flash at the currently selected tempo. If the OVERALL CONTROL section [METRONOME] button indicator is lit, the metronome will sound at the currently selected tempo. The current measure number – in this case “001” – will be shown on the MULTI DISPLAY.



- Accompaniment track recording is carried out using the currently selected Auto Accompaniment fingering mode (page 21).
- The record-ready mode of the ACCOMP track can be disengaged by pressing the [ACCOMP] track button. Pressing the [SYNC-START/STOP] button does not cancel the record-ready mode.
- It is also possible to record the MELODY track at the same time as you record the ACCOMP track. Hold the [REC] button and press the MELODY track button after engaging the ACCOMP track record ready mode. Refer to “Melody Track Recording” on page 35.
- Turning the power OFF during record-ready mode of the Song Memory erases the song data in the currently selected page.

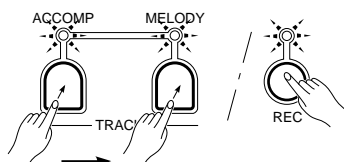

# Record Functions

## 4 Record

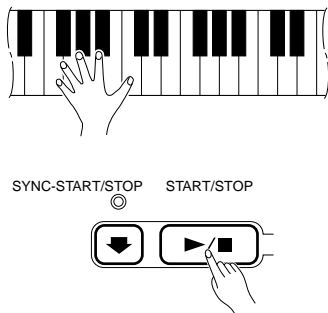

Recording will begin as soon as you play a chord on the Auto Accompaniment section of the keyboard. If you've selected a MELODY track to record with the ACCOMP track, a right-hand note will also start the recording process. The [REC] indicator lights continuously once recording has started, and the current measure number will appear on the MULTI DISPLAY.

Recording can also be started by pressing the ACCOMPANIMENT CONTROL [START/STOP] button. In this case only the rhythm will begin without bass and chord accompaniment until you play the first chord on the Auto Accompaniment section of the keyboard.

Play the required chords in the Auto Accompaniment section of the keyboard. If you've also selected the MELODY track to be recorded, play the melody on the right-hand section of the keyboard.

### NOTES

- Whenever you record using the SONG MEMORY, any previously recorded material in the same track will be erased and replaced by the new material.
- You can also start recording from any specified measure — see page 37.
- If the SONG MEMORY becomes full while recording, "End" will appear on the MULTI DISPLAY and recording will stop. Up to approximately 1,600 notes can be recorded in the MELODY track in each PAGE MEMORY. Up to approximately 1,600 chords can be recorded in each PAGE MEMORY. These figures only apply, however, if only chords or notes are recorded. The total is reduced when notes and chords are recorded together.
- If the previously-recorded SONG MEMORY MELODY track is turned ON (its indicator is lit), it can be monitored while recording. If you don't want to hear the previous track while recording, simply press the SONG MEMORY MELODY track button so its indicator goes out.
- If you start recording by pressing the [PLAY/STOP] button, nothing will be recorded until you begin playing on the keyboard.
- If you use a function button during recording the corresponding value will appear on the MULTI DISPLAY when the button is pressed. The measure number display will resume a few seconds after the button is released.

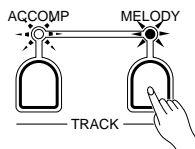

## 5 Stop Recording

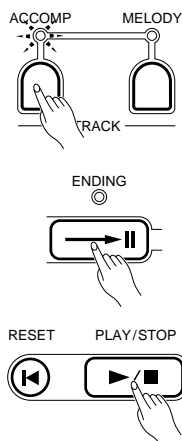

Stop recording by pressing the [ACCOMP] track button. Recording can also be stopped by pressing the [ENDING] button, or the SONG [PLAY/STOP] button. The [REC] indicator will go out and the voice number will be shown on the MULTI DISPLAY a few seconds after recording is stopped. Song memory will return to the measure at which recording was started.

### NOTES

- "..." will appear on the MULTI DISPLAY while the PSR-410 is processing recorded data.

## ■ Melody Track Recording

The SONG MEMORY MELODY track records the following operations and data:

- Key on/off (i.e. notes played on the keyboard).
- Key velocity.
- Voice number (Percussion Kit Number).
- Volume.
- Pan.
- Harmony on/off & harmony type.
- Sustain (footswitch) on/off.
- Pitch bend.
- Octave.

\* MULTI PAD data cannot be recorded to SONG MEMORY.

### 1 Select a Voice and Set the Voice Parameters

Select the voice you want to record with (the R1 and R2 voices can be used), and set the voice effects and other parameters as required.

### 2 Engage the MELODY Track Record Ready Mode

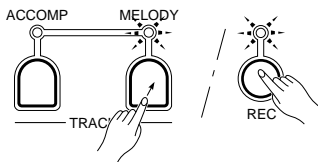

Press the MELODY track button while holding the RECORDING section [REC] button. Both the [REC] button indicator and the MELODY track indicator will flash, indicating that the SONG MEMORY is ready to record. If the OVERALL CONTROL section [METRONOME] button indicator is lit the metronome will also begin to sound at the currently selected tempo, while the MULTI DISPLAY BEAT indicator dots flash at the current tempo. The current measure number – in this case “001” – will be shown on the MULTI DISPLAY.



- If the previously-recorded SONG MEMORY ACCOMP track is turned ON (its indicators is lit), it can be monitored while recording. If you don't want to hear the ACCOMP track while recording, simply press the ACCOMP track button so its indicator goes out.
- If the MELODY track record ready mode is engaged, Auto Accompaniment is automatically turned off.

### 3 Record

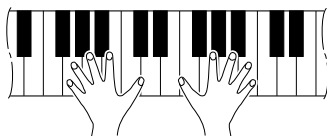

Recording will begin as soon as you play a note on the keyboard or press the SONG [PLAY/STOP] button, and the BEAT indicator dots will begin to indicate the current beat as in the Auto Accompaniment mode, and the current measure number will appear on the MULTI DISPLAY.

Play the melody using the entire keyboard if you are recording only the MELODY track, or on the right-hand section of the keyboard if you are recording the MELODY track at the same time as the ACCOMP track.

### 4 Stop Recording

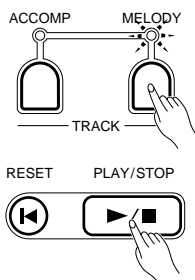

Stop recording by pressing the MELODY track button, or the SONG MEMORY [PLAY/STOP] button. The [REC] indicator will go out and the voice number will be shown on the MULTI DISPLAY a few seconds after recording is stopped. Song memory will return to the measure at which recording was started.



- “---” will appear on the MULTI DISPLAY while the PSR-410 is processing recorded data.

# Record Functions

## ■ Accompaniment And Melody Playback

### 1 Select a PAGE MEMORY

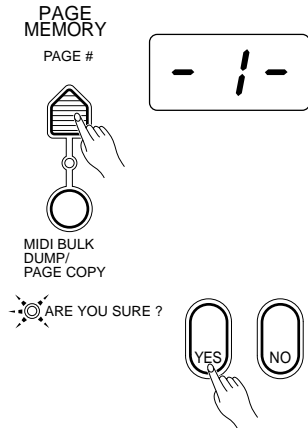

If necessary, press the [PAGE #] button to select the PAGE MEMORY number containing the song you want to play back. When a new PAGE MEMORY number is selected the ARE YOU SURE? indicator will flash and the “Are you sure?” prompt will sound. Press the [YES] button to select the specified page number or the [NO] button to cancel (see page 41 for more details).



- After the “Are you sure?” prompt, the PortaTone will wait until you press [YES] or [NO].

### 2 Select the Tracks to Play Back

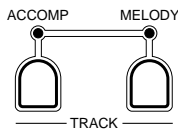

The MELODY and ACCOMP tracks can be played back individually or at the same time. Press the SONG MEMORY TRACK buttons corresponding to the tracks you want to play back — the indicators of the selected tracks will light.



- SONG MEMORY tracks that contain recorded data are automatically turned ON when a PAGE MEMORY is selected.

### 3 Start Playback

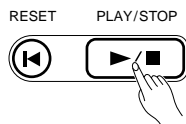

Playback will begin as soon as the SONG [PLAY/STOP] button is pressed. You can turn the ACCOMP and MEMORY tracks on and off during playback by pressing the appropriate TRACK buttons. During playback the current measure number will appear on the MULTI DISPLAY.



- Use the [RESET] button to return to the first measure of the song at any time (see page 37).
- You can also start playback from any specified measure by using the [MEASURE #] button (see page 37).

### 4 Play Along If You Like

Play along on the keyboard if you like. You can also change the tempo during playback.



- The maximum polyphony is 28. If more than 28 notes are played at the same time, some notes may be truncated.

### 5 Stop Playback

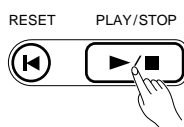

Accompaniment and melody playback will stop automatically when all recorded data has been played back. You can also stop playback at any time by pressing the SONG [PLAY/STOP] button.

## ■ The [RESET] Button

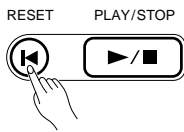

Press the SONG [RESET] button to go directly to the first measure of the song and turn ON all tracks that contain data. Measure number “001” will appear on the MULTI DISPLAY. The [RESET] button also functions during playback or recording.

## ■ Record Or Play from a Specified Measure

You can start SONG MEMORY recording or playback from any specified measure, as long as the specified measure is within the range of measures that has already been recorded:

### 1 Press the [MEASURE #] Button If Necessary .....



If the measure number is not currently shown on the MULTI DISPLAY, press the [MEASURE #] button. If the measure number is already showing, go directly to step 2.

### 2 Enter the Desired Measure Number .....

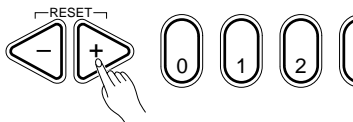

Use the [+ ] and [- ] buttons, the number buttons, or the [MEASURE #] button itself to enter the desired measure number.

### 3 Start Playback or Recording .....

Start playback or recording. You can now start playback or recording from the specified measure number.



- This function allows you to “punch-in” and “punch-out” at any measure to re-record a section of a previously-recorded track.

#### Example:

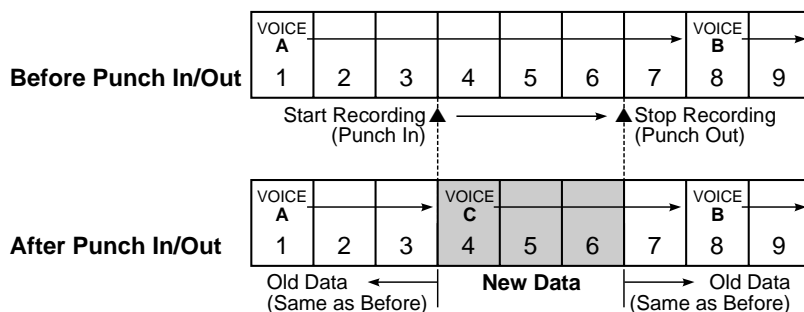

- Voice, volume, pan, pitch bend, tempo, harmony on/off, dual on/off, and revoice data changes made during the punch-in remain in effect even after the punch-out point, until further parameter changes are encountered in the old data.



- Recording is carried out in 1-measure units, so if you punch out in the middle of measure rests will be recorded for the remainder of that measure.

# Record Functions

## The Multi Pads

The PSR-410 MULTI PADS can be used to record short rhythmic or melodic sequences, percussion fill-ins, or single percussion sounds that can be played at any time simply by pressing the appropriate pad. Pads [1] and [2] play back exactly as recorded, while pads [3] and [4] are “CHORD MATCH” types which are automatically transposed to match chords played using the PSR-410 Auto-accompaniment feature.

Each PAGE MEMORY holds a different set of MULTI PAD data, and these can be selected and played back simply by selecting the appropriate PAGE MEMORY.

The MULTI PADS record the following operations and data:

- Key on/off (i.e. notes played on the keyboard).
- Key velocity.
- Voice number (Percussion Kit Number).
- Volume.
- Pan.
- Octave.
- Harmony on/off & harmony type.
- Sustain on/off.
- Pitch bend.

### NOTES

- Before recording, each PAGE MEMORY contains a preset set of MULTI PAD data — 16 phrases in all — that will be erased when new MULTI PAD data is recorded. The original preset data can be restored by using the “Page Reset” function described on page 51.

The illustrations here are not available.

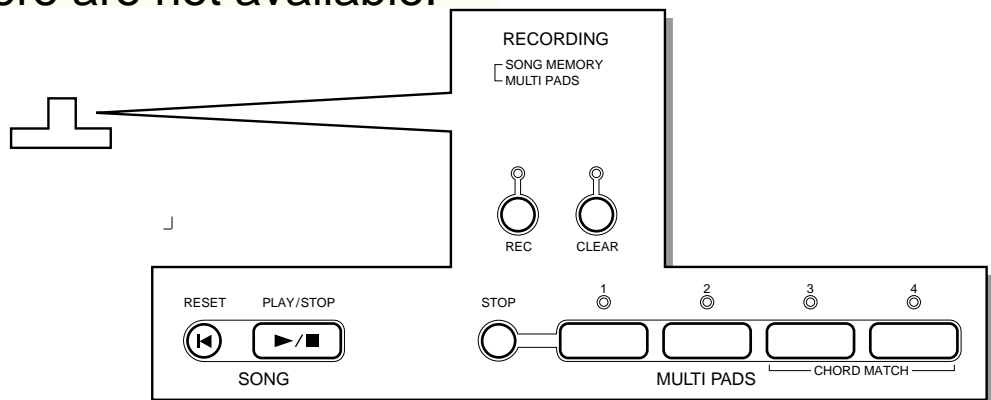

## Recording

### 1 Select a PAGE MEMORY

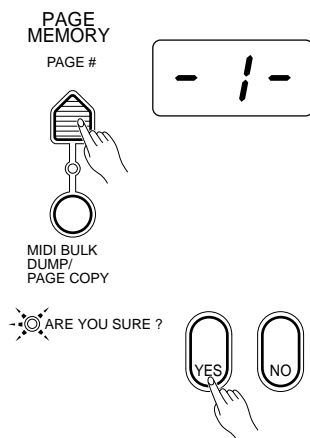

If necessary, press the [PAGE #] button to select the PAGE MEMORY number to which you want to record. When a new PAGE MEMORY number is selected the ARE YOU SURE? indicator will flash and the “Are you sure?” prompt will sound. Press the [YES] button to select the specified page number or the [NO] button to cancel (see page 41 for more details).

### NOTES

- After the “Are you sure?” prompt, the PortaTone will wait until you press [YES] or [NO].

### 2 Select a Voice to Record and an Appropriate Tempo

Select the voice you want to record on the MULTI PADS. Only the [R1] and [R2] voices can be used. You might also want to set a tempo that will be easy to record at.

### 3 Engage the MULTI PAD Record Ready Mode .....

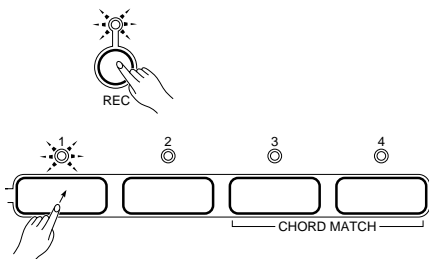

Press one of the MULTI PAD buttons — [1] through [4] — while holding the [REC] button. The [REC] button indicator and the selected MULTI PAD indicator will flash to indicate that the record ready mode is engaged, and the metronome will begin to sound at the currently selected tempo if the OVER-ALL CONTROL section [METRONOME] button indicator is lit.

#### NOTES

- Only the R1 and R2 orchestration parts can be recorded to the MULTI PADS.
- If the MULTI PAD record ready mode is engaged, Auto Accompaniment is automatically turned off.
- Turning the power OFF during record-ready mode of the Multi Pad erases the Multi Pad data in the currently selected page and restores its default data.

### 4 Record .....

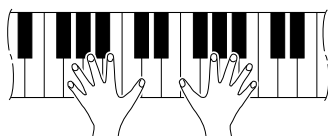

#### NOTES

Play a short sequence. The MULTI PADS can record up to approximately 450 quarter notes in each PAGE MEMORY. The [REC] button indicator will light during recording, and the BEAT indicator will indicate the current beat as in the Auto Accompaniment mode.

- Whenever you record to a MULTI PAD, all previous data in the same pad will be completely erased and replaced by the new material.
- Recording can also be started by pressing the [PLAY/STOP] button.
- When recording the CHORD MATCH pads — [3] and [4] — base all melodic and chordal phrases on a CM7 chord so that the sound will be properly transposed when used with the Auto Accompaniment feature (see “Playback” below).

### 5 Stop Recording .....

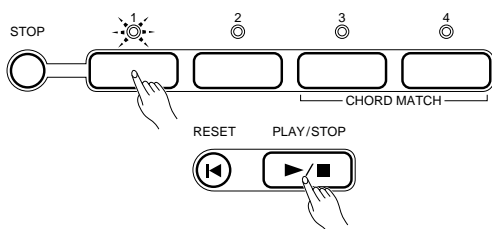

Press the MULTI PAD button being recorded, the MULTI PAD [STOP] button, or the [PLAY/STOP] button to stop recording. Recording will also stop automatically and “End” will appear on the MULTI DISPLAY when the pad memory becomes full.

## ■ Playback .....

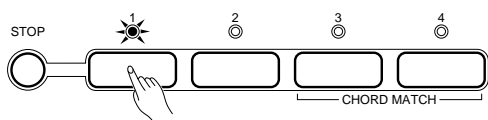

Simply tap any of the MULTI PADS at any time to play back the data they contain. MULTI PAD playback begins as soon as the button is pressed. You can even play two, three, or four MULTI PADS at the same time. Also, you can create “retriggered sample” effects by repeatedly pressing a pad before its contents are completely played back.

The MULTI PAD voices are independent from the voices you have currently selected for keyboard performance. You could, for example, play piano on the keyboard while a MULTI PAD plays a brass chord stab.

MULTI PADS [3] and [4] are “CHORD MATCH” types, and the data they contain will be automatically transposed to match chords played using the PSR-410 Auto Accompaniment feature.

MULTI PAD playback can be terminated by pressing the MULTI PADS [STOP] button.

#### NOTES

- MULTI PAD playback speed is determined by the current TEMPO setting.
- The contents of the MULTI PAD memory are retained in memory even when the power is turned off as long as batteries are present or an AC adapter is connected to the PSR-410 (see “PAGE MEMORY” on page 41 for details).
- Percussion data recorded to either of the CHORD MATCH pads will play back in the same way as the normal pads.

## Clearing Tracks

The [CLEAR] button can be used to completely erase the following data:

- All data after the current measure in the specified SONG MEMORY track.
- All data from the specified MULTI PAD.

### 1 For a SONG MEMORY Track, Set the Start Measure .....

MEASURE #



Use the [MEASURE #] button to set the first measure to be cleared (page 37). All subsequent measures up to the end of the song will be cleared.

### 2 Specify the Track or Pad to Be Cleared .....



Press the appropriate track or pad button while holding the [CLEAR] button. The ARE YOU SURE? indicator will light and the PSR-410 will ask “Are you sure?”



• *Turning the power OFF during clear-ready mode can result in a loss of recorded data.*

### 3 Confirm or Cancel the Clear Operation .....

ARE YOU SURE?

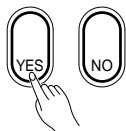

Press the [YES] button if you want to go ahead with the clear operation, thus erasing the selected track or pad. Press [NO] to cancel the operation and preserve the contents of the track or pad. “---” will appear on the MULTI DISPLAY while the data is being cleared.

# Page Memory

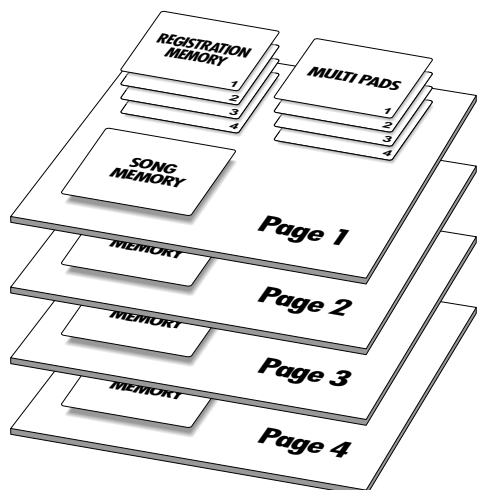

In addition to the REGISTRATION MEMORY described on page 31, the PSR-410 has a PAGE MEMORY that stores panel control and parameter settings plus the contents of the SONG MEMORY, and MULTI PADS. There are four PAGE MEMORY locations, each holding a complete set of parameters and recorded data. The PAGE MEMORY locations are selected as follows:

The illustrations here are not available.

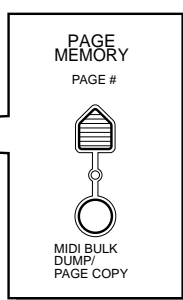

## PAGE MEMORY Data

- Registration Memory contents.
- Song Memory contents.
- Multi Pad contents.

### 1 Press the [PAGE #] Button

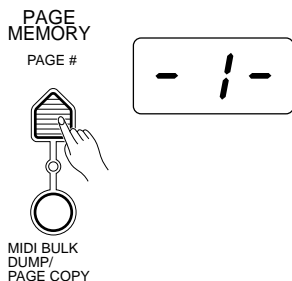

Press the [PAGE #] button once and the current page number will appear on the MULTI DISPLAY.



- Page 1 is automatically selected whenever the power switch is turned on.
- The Page Memory settings are retained in memory even when the power is turned OFF as long as batteries are installed or an AC adaptor is connected to the PSR-410.

### 2 Select a Page Number

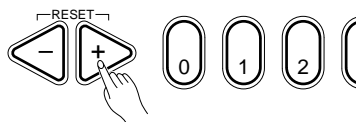

Use the [+], [-] buttons, the number buttons, or the [PAGE #] button itself to select the required page number (1 ... 4). When a new PAGE MEMORY number is selected the ARE YOU SURE? indicator will flash and the “Are you sure?” prompt will sound.



- The PAGE MEMORY page number cannot be changed while Auto Accompaniment or DEMO function is engaged.

### 3 Confirm the Selection



Press the [YES] button to select the specified page number or the [NO] button to cancel.



- The panel settings remain the same unless you press the [YES] button.
- All Registration Memory and recorded data changes are automatically stored in the currently selected PAGE MEMORY, so there's no particular PAGE MEMORY recording procedure.
- Data can be copied from one PAGE MEMORY location to another by using the MIDI BULK DUMP/PAGE COPY function described on page 44.

MIDI, the Musical Instrument Digital Interface, is a world-standard communication interface that allows MIDI-compatible musical instruments and equipment to share musical information and control one another. This makes it possible to create “systems” of MIDI instruments and equipment that offer far greater versatility and control than is available with isolated instruments.

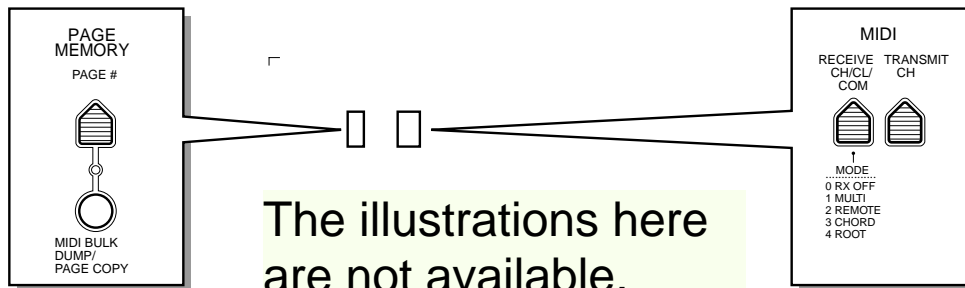

## ● The PSR-410 MIDI Connectors .....

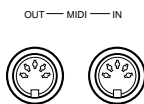

The PSR-410 MIDI IN connector receives MIDI data from an external MIDI device which can be used to control the PSR-410. The MIDI OUT connector transmits MIDI data generated by the PSR-410 (e.g. note and velocity data produced by playing the keyboard).

## ● Simple MIDI Control .....

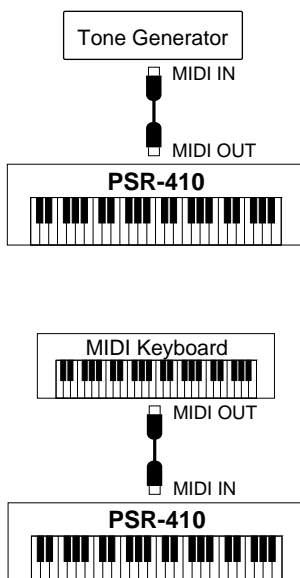

Most MIDI keyboards (including the PSR-410, of course) transmit note and velocity (touch response) information via the MIDI OUT connector whenever a note is played on the keyboard. If the MIDI OUT connector is connected to the MIDI IN connector of a second keyboard (synthesizer, etc.) or a tone generator (essentially a synthesizer with no keyboard), the second keyboard or tone generator will respond precisely to notes played on the original transmitting keyboard. The result is that you can effectively play two instruments at once, providing thick multi-instrument sounds. The PSR-410 also transmits “program change” data when one of its voices is selected. Depending on how the receiving device is set up, the corresponding voice will be automatically selected on the receiving keyboard or tone generator whenever a voice is selected on the PSR-410.

The PSR-410 is capable of receiving the same MIDI data, so a second MIDI keyboard connected to the PSR-410 MIDI IN connector can be used to remotely play the PSR-410 and select voices as required.

## ● MIDI Sequence Recording .....

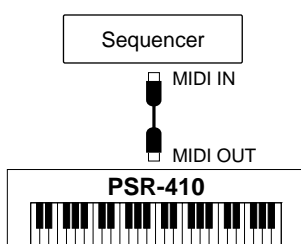

Although the PSR-410 features a built-in “sequencer” (the SONG MEMORY is a type of sequencer), the same type of musical information transfer described above can be used for more sophisticated MIDI sequence recording using an external sequencer or music computer. A MIDI sequence recorder or music computer can be used to “record” MIDI data received from a PSR-410, for example. When the recorded data is played back, the PSR-410 automatically “plays” the recorded performance in precise detail.



• Never use MIDI cables longer than about 15 meters, since cables longer than this can pick up noise which can cause data errors.

# MIDI Bulk Dump

MIDI bulk dump operations allow large amounts of MIDI data to be transmitted from one device to another. The entire contents of the currently selected PSR-410 PAGE MEMORY (MULTI PADS, SONG MEMORY, REGISTRATION MEMORY) can be dumped to a second PSR-410 or to a bulk storage device such as a MIDI data recorder or MIDI computer.

## 1 Make the Required MIDI Connections

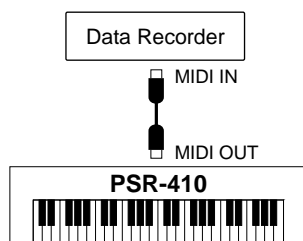

Connect the PSR-410 MIDI OUT terminal to the MIDI IN terminal of the device which is to receive the bulk data.



- You may also have to set up the receiving device to receive the bulk data. Refer to the receiving device's operation manual for MIDI bulk dump reception details.

## 2 Select a PAGE MEMORY

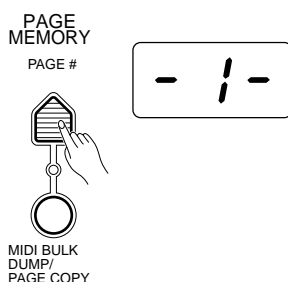

Select the PAGE MEMORY number you want to transmit (page 41).

## 3 Press the [MIDI BULK DUMP/PAGE COPY] Button

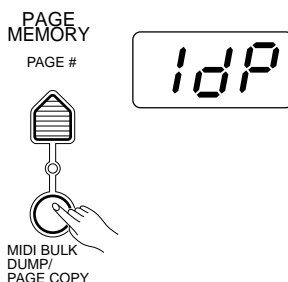

Press the [MIDI BULK DUMP/PAGE COPY] button. The “ARE YOU SURE?” indicator will flash and the PSR-410 will ask “Are you sure?”. At the same time “1dP”, “2dP”, “3dP”, or “4dP” will appear on the MULTI DISPLAY, depending on the selected PAGE MEMORY number.

## 4 Press [YES] to Transmit

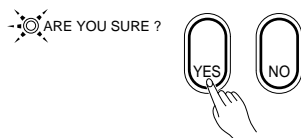

Press the [YES] button to execute the bulk dump operation, or the [NO] button to cancel and return to the VOICE SELECT mode.

The [MIDI BULK DUMP/PAGE COPY] button indicator will light during bulk dump transmission, and will go out when the transmission has finished. The progress of the bulk dump transmission ([-S-]→[-n-]→[-r-]) will also be indicated on the MULTI DISPLAY. When all the data has been transmitted the PSR-410 will automatically return to the VOICE SELECT mode.



- All of the PSR-410 panel controls are disabled during bulk dump transmission.
- Each letter, appears in order on the MULTI DISPLAY, indicates that the following data is sent: [-S-] for Song Memory data, [-n-] for Multi Pad data, [-r-] for Registration Memory data.

## ● Bulk Dump Reception .....

The PSR-410 will automatically receive bulk dump data from another PSR-410 or MIDI data storage device as long as the MIDI OUT terminal of the external device is properly connected to the MIDI IN connector of the PSR-410, and PSR-410 MIDI reception is enabled.

When this occurs the [MIDI BULK DUMP/PAGE COPY] indicator will light and all panel controls will be disabled during reception. The progress of the bulk dump reception ([-S-]→[-n-]→[-r-]) will be indicated on the MULTI DISPLAY in the same as for bulk dump transmission. When all the data has been received, the [MIDI BULK DUMP/PAGE COPY] indicator will go out and all panel settings will correspond with the received bulk dump data (the received data is saved to the currently selected PAGE MEMORY).



- **If an error occurs during bulk dump reception, “Err” will appear on the MULTI DISPLAY and all data in the block in which the error occurred will be initialized (i.e. the corresponding settings will be reset to their power-on values).**
- **When a bulk dump is received, the contents of the currently selected PAGE MEMORY are erased and replaced by the received data.**
- **A bulk dump from an external device cannot be received during recording or Auto Accompaniment playback.**
- **“-S-”, “-n-”, or “-r-” will remain on the MULTI DISPLAY for a short while after bulk dump reception has finished while the received data is being processed.**

## ■ Page Copy .....

The [MIDI BULK DUMP/PAGE COPY] button can also be used to copy the entire contents of one PAGE MEMORY number to any other, rather than transmitting the data via the MIDI OUT terminal.

### 1 Select the PAGE MEMORY Number You Want to Copy .....

Select the PAGE MEMORY number you want to copy to a different number (page 41).

### 2 Press the [MIDI BULK DUMP/PAGE COPY] Button .....

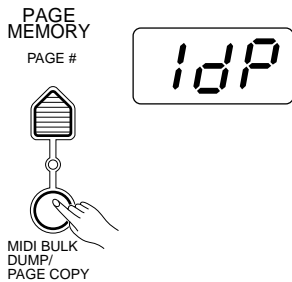

Press the [MIDI BULK DUMP/PAGE COPY] button. The “ARE YOU SURE?” indicator will flash and the PSR-410 will ask “Are you sure?”. At the same time “1dP”, “2dP”, “3dP”, or “4dP” will appear on the MULTI DISPLAY, depending on the selected PAGE MEMORY number.

### 3 Select the Destination PAGE MEMORY Number .....

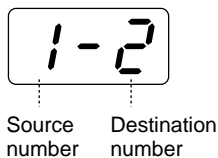

Use the [+] and [-] buttons to select the PAGE MEMORY number to which you want to copy the data. The source PAGE MEMORY number appears on the left digit of the MULTI DISPLAY while the destination PAGE MEMORY number appears on the right digit.

### The Page Reset Function

When “cL” appears to the right of the page number on the MULTI DISPLAY the page reset function is selected. If you press [YES] to execute the operation as described in the next step, all settings in the selected page will be reset to their initial values.

### 4 Press [YES] to Copy .....

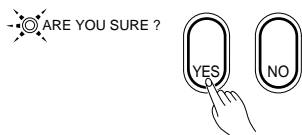

Press the [YES] button to execute the page copy operation, or the [NO] button to cancel and return to the VOICE SELECT mode.

When the data has been copied (this only takes about a second) the PSR-410 will automatically return to the VOICE SELECT mode.

# MIDI Reception Modes

The [RECEIVE CH/CL/COM] button is used to specify the reception mode for each of the 16 MIDI channels, the internal or external clock mode, and MIDI start/stop command reception mode.

## Channel Reception Modes

The PSR-410 allows any of five reception modes to be individually assigned to MIDI channels 1 through 16. The five modes are:

**Mode “0” RX OFF:** Reception disabled.

**Mode “1” MULTI:** Received MIDI note data directly controls the PSR-410 tone generator. Different voices can be played on different channels.

**Mode “2” REMOTE:** Received MIDI note data is handled in the same way as data from the PSR-410’s own keyboard.

**Mode “3” CHORD:** Received MIDI note data is interpreted as Auto Accompaniment chord commands.

**Mode “4” ROOT:** Received MIDI note data is interpreted as Auto Accompaniment bass note commands.



- The send channel must correspond to the channel set for the modes 2-4.
- If the PSR-410 receives more than one note at the same time while mode “4” (ROOT) is selected, the last note will be interpreted as the Auto Accompaniment bass note.

### 1 Press the [RECEIVE CH/CL/COM] Button & Select a Channel .....

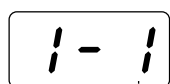

Channel number



Press the [RECEIVE CH/CL/COM] button, then use the [+] and [-] buttons, the number buttons, or the [RECEIVE CH/CL/COM] button itself to select the MIDI channel (1 ... 16) for which you want to specify a new reception mode. The channel number appears on the right of the MULTI DISPLAY.



- “cL” and “cd” will appear on the right of the display if you increment above channel number 16 or below channel number 1. These selections are used for the Clock Mode and Start/Stop Mode functions described below.

### 2 Select the Desired Mode .....

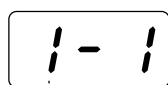

Mode number

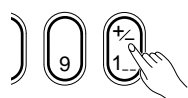

Use the [+/-] button in the number-button row to select the desired reception mode for the selected channel. The modes are selected in sequence each time the [+/-] button is pressed, and the mode number appears on the left digit of the MULTI DISPLAY.



- The currently selected reception mode is retained in memory even when the power switch is turned off, as long as batteries are installed or an AC adaptor is connected.

## ■ Clock Mode

Reception of an external MIDI clock signal can be enabled or disabled as required. When disabled, all of the PSR-410's time-based functions (Auto Accompaniment, SONG MEMORY, etc.) are controlled by its own internal clock, the speed of which is set by the PSR-410 [TEMPO] button. When MIDI clock reception is enabled, however, all timing is controlled by an external MIDI clock signal received via the PSR-410 MIDI IN terminal (the PSR-410 [TEMPO] setting has no effect).



- If clock reception is enabled but no MIDI clock signal is received for more than 400 milliseconds, external clock reception is automatically disabled and normal internal clock operation resumes.
- If you attempt to change the tempo setting when MIDI clock reception is enabled, "EC" will appear on the MULTI DISPLAY.

### 1 Press the [RECEIVE CH/CL/COM] Button & Select "cL" .....

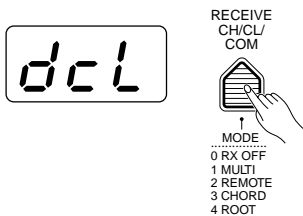

Press the [RECEIVE CH/CL/COM] button, then use the [+] and [-] buttons, the number buttons, or the [RECEIVE CH/CL/COM] button itself to select "cL" on the MULTI DISPLAY ("cL" is the next step above MIDI channel 16).

### 2 Select the Desired Mode .....

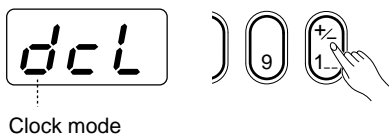

Use the [+/-] button in the number-button row to select the desired clock mode. The disable and enable modes are selected alternately each time the [+/-] button is pressed, and the selected mode appears on the left digit of the MULTI DISPLAY ("d" for disable; "E" for enable).

## ■ Start/Stop Mode

This function determines the effect of external MIDI start and stop signals. There are three start/stop modes, as follows:

- Mode "0"** Start/stop reception disabled.
- Mode "1"** MIDI start and stop commands start and stop the PSR-410 Auto Accompaniment feature.
- Mode "2"** MIDI start and stop commands start and stop the PSR-410 SONG MEMORY feature.

### 1 Press the [RECEIVE CH/CL/COM] Button & Select "cd" .....

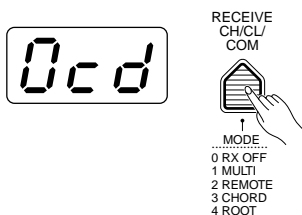

Press the [RECEIVE CH/CL/COM] button, then use the [+] and [-] buttons, the number buttons, or the [RECEIVE CH/CL/COM] button itself to select "cd" on the MULTI DISPLAY ("cd" is the next step above "cL" — or the next step below MIDI channel 1).

### 2 Select the Desired Mode .....



Use the [+/-] button in the number-button row to select the desired start mode. The start/stop modes are selected in sequence each time the [+/-] button is pressed, and the selected mode number appears on the left digit of the MULTI DISPLAY.

# MIDI Transmission

The PSR-410 allows any of the 16 MIDI transmit channels to be assigned to the R ORCHESTRATION voices.

## MIDI Transmit Channels

The R ORCHESTRATION voices can be set to transmit on any of the 16 MIDI channels as follows:

### 1 Press the [TRANSMIT CH] button .....



Press the [TRANSMIT CH] button to set the R voice transmit channel. The currently selected channel will appear on the MULTI DISPLAY.



- After selecting the transmit channel function, as described above, the default transmit channel can be recalled by simultaneously pressing the [+] and [-] buttons. The default "R" transmit channel is "1". The "L" voices are transmitted on channel 2.

### 2 Select the Desired Transmit Channel .....

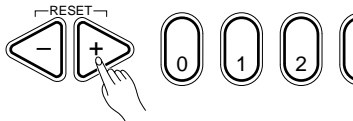

Use the [+] and [-] buttons, the number buttons, or the [TRANSMIT CH] button itself to select the desired transmit channel.



- The currently selected transmit channel is retained in memory even when the power switch is turned off, as long as batteries are installed or an AC adaptor is connected.
- To record the Song Memory data to an external sequencer, start the sequencer running in the record mode, press the [RESET] button, and then press the [PLAY/STOP] button.
- To record the Auto Accompaniment data to an external sequencer, start the sequencer running in the record mode, select the style you want to record, then start Auto Accompaniment playback.
- Notes played on the keyboard are transmitted on channel 1 (selectable) or 2, Auto Accompaniment data is transmitted on channels 10 - 16, and Song Memory melody data is transmitted on channel 3. Normally the Auto Accompaniment Rhythm 1 and Rhythm 2 data are both transmitted on channel 10. To transmit these tracks separately, hold the C1 key while turning the power on. When this is done the Rhythm 1 data will be transmitted on channel 9 while the Rhythm 2 data will be transmitted on channel 10.

# Appendix

## Voice & Polyphony List

The PSR-410 can play up to 28 individual notes at the same time (i.e. it has a maximum “polyphony” of 28). This number includes all voices used: dual, split, auto accompaniment, song memory, and multi pads. If the maximum polyphony of the PSR-410 is exceeded, the excess notes will be truncated (they will not sound).

Another feature affecting polyphony is the fact that some PSR-410 voices actually use two voices at once, as shown in the voice list below. The effective maximum polyphony of the PSR-410 is correspondingly reduced when these voices are used.



• The voice list includes the MIDI program numbers that control each voice when the PSR-410 is played from an external MIDI device.

Voice Number	MIDI Program Number	Voice Name	Number of Voices Used	Voice Number	MIDI Program Number	Voice Name	Number of Voices Used	Voice Number	MIDI Program Number	Voice Name	Number of Voices Used
<b>Piano</b>				45	44	Tremolo Strings	2	<b>Synth Pad</b>			
01	0	Acoustic Grand Piano	1	46	45	Pizzicato Strings	2	89	88	Pad 1 (new age)	2
02	1	Bright Acoustic Piano	1	47	46	Orchestral Harp	1	90	89	Pad 2 (warm)	2
03	2	Electric Grand Piano	2	48	47	Timpani	1	91	90	Pad 3 (polysynth)	2
04	3	Honky-tonk Piano	2	<b>Ensemble</b>				92	91	Pad 4 (choir)	2
05	4	Electric Piano 1	2	49	48	Strings Ensemble 1	1	93	92	Pad 5 (bowed)	2
06	5	Electric Piano 2	2	50	49	Strings Ensemble 2	1	94	93	Pad 6 (metallic)	2
07	6	Harpsichord	1	51	50	Synth Strings 1	2	95	94	Pad 7 (halo)	2
08	7	Clavi	1	52	51	Synth Strings 2	2	96	95	Pad 8 (sweep)	2
<b>Chromatic Percussion</b>				53	52	Choir Aahs	2	<b>Synth Effects</b>			
09	8	Celesta	1	54	53	Voice Oohs	1	97	96	FX 1 (rain)	2
10	9	Glockenspiel	1	55	54	Synth Voice	1	98	97	FX 2 (soundtrack)	2
11	10	Music Box	2	56	55	Orchestra Hit	1	99	98	FX 3 (crystal)	2
12	11	Vibraphone	1	<b>Brass</b>				100	99	FX 4 (atmosphere)	2
13	12	Marimba	1	57	56	Trumpet	1	101	100	FX 5 (brightness)	2
14	13	Xylophone	1	58	57	Trombone	1	102	101	FX 6 (goblins)	2
15	14	Tubular Bells	1	59	58	Tuba	1	103	102	FX 7 (echoes)	2
16	15	Dulcimer	2	60	59	Muted Trumpet	1	104	103	FX 8 (sci-fi)	2
<b>Organ</b>				61	60	French Horn	1	<b>Ethnic</b>			
17	16	Drawbar Organ	2	62	61	Brass Section	1	105	104	Sitar	1
18	17	Percussive Organ	2	63	62	Synth Brass 1	2	106	105	Banjo	1
19	18	Rock Organ	2	64	63	Synth Brass 2	2	107	106	Shamisen	1
20	19	Church Organ	2	<b>Reed</b>				108	107	Koto	1
21	20	Reed Organ	1	65	64	Soprano Sax	1	109	108	Kalimba	1
22	21	Accordion	2	66	65	Alto Sax	1	110	109	Bagpipe	2
23	22	Harmonica	1	67	66	Tenor Sax	1	111	110	Fiddle	1
24	23	Tango Accordion	2	68	67	Baritone Sax	1	112	111	Shanai	1
<b>Guitar</b>				69	68	Oboe	1	<b>Percussive</b>			
25	24	Acoustic Guitar (nylon)	1	70	69	English Horn	1	113	112	Tinkle Bell	2
26	25	Acoustic Guitar (steel)	1	71	70	Bassoon	1	114	113	Agogo	1
27	26	Electric Guitar (jazz)	1	72	71	Clarinet	1	115	114	Steel Drums	2
28	27	Electric Guitar (clean)	2	<b>Pipe</b>				116	115	Woodblock	1
29	28	Electric Guitar (muted)	1	73	72	Piccolo	1	117	116	Taiko Drum	1
30	29	Overdriven Guitar	1	74	73	Flute	1	118	117	Melodic Tom	1
31	30	Distortion Guitar	1	75	74	Recorder	1	119	118	Synth Drum	1
32	31	Guitar Harmonics	1	76	75	Pan Flute	1	120	119	Reverse Cymbal	1
<b>Bass</b>				77	76	Blown Bottle	2	<b>Sound Effects</b>			
33	32	Acoustic Bass	1	78	77	Shakuhachi	1	121	120	Guitar Fret Noise	1
34	33	Electric Bass (finger)	1	79	78	Whistle	1	122	121	Breath Noise	1
35	34	Electric Bass (pick)	1	80	79	Ocarina	1	123	122	Seashore	2
36	35	Fretless Bass	1	<b>Synth Lead</b>				124	123	Bird Tweet	2
37	36	Slap Bass 1	1	81	80	Lead 1 (square)	2	125	124	Telephone Ring	1
38	37	Slap Bass 2	1	82	81	Lead 2 (sawtooth)	2	126	125	Helicopter	2
39	38	Synth Bass 1	1	83	82	Lead 3 (calliope)	2	127	126	Applause	2
40	39	Synth Bass 2	1	84	83	Lead 4 (chiff)	2	128	127	Gunshot	1
<b>Strings</b>				85	84	Lead 5 (charang)	2				
41	40	Violin	1	86	85	Lead 6 (voice)	2				
42	41	Viola	1	87	86	Lead 7 (fifth)	2				
43	42	Cello	1	88	87	Lead 8 (bass+Lead )	2				
44	43	Contrabass	1								

\* The following voices use only one voice in the indicated ranges: 46 (Pizzicato Strings): all notes below C#2 and above F5. 110 (Bagpipe): all notes above A#2.

## Style List

#	Name	Panel Name	Rhythm	Comments
<b>Pop</b>				
01	16-Beat Pop	16BEAT POP	16-Beat	Contemporary 16-beat pop.
02	8-Beat Pop	8BEAT POP	8-Beat	Bright piano/guitar-based '70s pop.
03	8-Beat Light	8BEAT LIGHT	8-Beat	Eight-beat easy-listening style with arpeggiated piano part.
04	FolkRock	FOLKROCK	16-Beat	Guitar-based folk-rock.
05	Pop Shuffle	POP SHUFFLE	12-Beat	'70s European pop shuffle.
06	Pop Rock	POP ROCK	12-Beat	Upbeat, fast pop-rock. Try using your own chords in the intro and ending.
<b>Pop Ballad</b>				
07	16-Beat Ballad	16BT BALLAD	16-Beat	Warm, romantic American soul ballad style.
08	Pop Ballad	POP BALLAD	8-Beat	Romantic pop ballad.
09	Piano Ballad	PNO BALLAD	8-Beat	Piano-based ballad with slow arpeggios. Huge drum fills in Intro and Fill In 2.
10	6/8 Ballad	6/8 BALLAD	Six-Eight	Slow rock ballad with triplet feel and classical overtones.
<b>Dance</b>				
11	Rave	RAVE	16-Beat	Hard-driving synth bass and "space bleep" synth percussion.
12	Eurobeat	EUROBEAT	16-Beat	Fast, 16-beat Eurobeat sound, for disco and house music.
13	Dance Pop	DANCE POP	16-Beat	'80s English disco sound.
14	Casa	CASA	16-Beat	Italian house music.
15	Rap	RAP	16-Beat	Modern rap/hip-hop rhythm with turntable scratching and other effects. RHYTHM 1 & 2 can stand on their own as basic rhythm tracks.
16	Dance Shuffle	DANCE SHFL	24-Beat	Rap/dance feel, especially for one-chord songs. Try playing with CHORD 1 & 2 off.
17	Groundbeat	GROUNDBEAT	24-Beat	Contemporary soul ballad with funky bass. PHRASE 1 adds high string lines and PHRASE 2 adds bass.
18	Synth Boogie	SY BOOGIE	Six-Eight	Fast, machine-like 6/8 computer groove with synth bass.
<b>Disco</b>				
19	Disco Party	DISCO PARTY	16-Beat	Big band disco party style, hugely popular in Europe.
20	Disco Soul	DISCO SOUL	16-Beat	Philadelphia disco style from the '70s.
21	Disco Pop	DISCO POP	16-Beat	The world-famous (and recently revived) '70s Swedish disco sound.
22	Polka Pop	POLKA POP	8-Beat	Updated Polkastyle. Latin percussion in Rhythm 2.
<b>Rhythm &amp; Blues</b>				
23	R&B	R&B	8-Beat	Eight-beat rhythm and blues from the '60s .
24	R&B Ballad	R&B BALLAD	16-Beat	Upbeat West Coast soul ballad.
25	6/8 Blues	6/8 BLUES	Six-Eight	New Orleans R&B from the '50s.
26	Blues Shuffle	BLUES	12-Beat	Chicago -type blues shuffle.
27	Soul	SOUL	8-Beat	Simple-but-effective Memphis R&B groove.
28	Funk	FUNK	16-Beat	Oakland's East Bay funk style, with fat horn section and big finale for ending.
29	Funk Shuffle	FUNK SHFL	24-Beat	Funky guitar and funky brass stabs in a funky organ-driven shuffle. Funky!
<b>Rock</b>				
30	Hard Rock	HARD ROCK	8-Beat	Fast, hard-driving rock. P2 brings in cymbal crashes with every chord change.
31	Rock Boogie	RK BOOGIE	12-Beat	Hard-driving boogie with distorted guitar.
32	Rock Pop	ROCK POP	8-Beat	Mid-tempo guitar-based rock
33	Rock Shuffle	RK SHUFFLE	12-Beat	Smooth pop-rock style. Try bringing in the instrument parts one by one.
34	6/8 Rock	6/8 ROCK	Six-Eight	Slow rock pattern with triplet feel and "House of the Rising Sun"-style arpeggios.
35	Rock Ballad	RK BALLAD	8-Beat	Slow rock ballad. Use RHYTHM 2 to add crash cymbal at chord changes. Take out PHRASE 1 & 2 (guitars) for smoother sound.
<b>Rock &amp; Roll</b>				
36	Rock & Roll	ROCK&ROLL	12-Beat	Old-time '60s Rock&Roll.
37	Boogie Woogie	BOOGIE	12-Beat	Late '50s piano-based rock 'n' roll, with boogie woogie bass. Brass in PHRASE 1 & 2, piano bass in PAD.
38	Twist	TWIST	8-Beat	Straight-eight boogie, with a "Twist."
39	Rockabilly	ROCKABILLY	12-Beat	Simple, updated version of the Memphis "Sun" sound.
<b>Traditional Jazz</b>				
40	Dixieland	DIXIELAND	12-Beat	Old-time New Orleans jazz. Trumpet at PHRASE 1, Trombone at PHRASE 2, and Clarinets at PAD.
41	Big Band	BIG BAND	12-Beat	Big Band orchestra style and instrumentation. Piano at CHORD 1, guitar at CHORD 2, trumpets at PHRASE 1, trombones at PHRASE 2, and saxes at PAD.

# Appendix

## ■ Style List

#	Name	Panel Name	Rhythm	Comments
42	Swing	SWING	12-Beat	European big-band swing style. Good for all mid-tempo swing tunes.
43	Foxtrot	FOXTROT	12-Beat	Strict tempo Foxtrot for ballroom dancing.
44	Swing Waltz	SWING WALTZ	Nine-Eight	Mid-tempo 9/8 waltz.
<b>Contemporary Jazz</b>				
45	BeBop	BEBOP	12-Beat	'40s New York fast BeBop style. Good also for instantly adding a double-time feel to any style!
46	Jazz Ballad	JAZZ BALLAD	12-Beat	Slow jazz style with piano, guitar, bass and brush drums. Turn off PHRASE 1 & 2 when playing piano melody. Use in medley with Big Band Ballad to change orchestration.
47	Jazz Waltz	JAZZ WALTZ	Nine-Eight	Swing style in 3/4 time for playing jazz waltz standards.
48	Fusion	FUSION	16-Beat	Latin flavored 16-beat fusion.
49	Fusion Shuffle	FUSION SHFL	24-Beat	West Coast type funk shuffle.
<b>Latin</b>				
50	Mambo	MAMBO	8-Beat	Contemporary Latin dance music. If playing the melody with a piano sound, turn off CHORD 2.
51	Merengue	MERENGUE	8-Beat	High-energy Latin style with lots of percussion and punchy brass.
52	Beguine	BEGUINE	8-Beat	Slow rhumba rhythm, a la "Begin the Beguine."
53	Tango Argentina	TANGO ARGN	8-Beat	Traditional ballroom style Tango.
54	Cha Cha	CHA CHA	8-Beat	Strict tempo ChaCha style for ballroom dancing. Try starting only with RHYTHM 2, BASS and CHORD, then bring in other instruments one by one.
55	Samba	SAMBA	16-Beat	Standard ballroom Samba. Guitar is at CHORD 1 & 2, with 2 playing the lower strings. Turning RHYTHM 2 on/off provides additional variation.
56	Bomba	BOMBA	16-Beat	Puerto Rican dance rhythm, cousin to the Merengue.
<b>Latin Pop</b>				
57	Pop Bossa	POP BOSSA	8-Beat	Soft, electric-piano based Latin pop sound.
58	Jazz Samba	JAZZ SAMBA	16-Beat	Traditional Brazilian samba with an added drum set.
59	Latin Rock	LATIN ROCK	16-Beat	Contemporary Cha Cha with electric bass and drum kit.
<b>Caribbean</b>				
60	Reggae 16	REGGAE 16	16-Beat	Modern Jamaican Reggae rhythm with fat synth bass.
61	Reggae 12	REGGAE 12	12-Beat	Reggae shuffle.
<b>Country &amp; Western</b>				
62	Bluegrass	BLUEGRASS	16-Beat	Try this one with just CHORD 1 and RHYTHM 1 at first, then build up the arrangement by adding different instruments.
63	Country Pop	C POP	8-Beat	Contemporary country style.
64	Country Rock	C ROCK	8-Beat	Soft country style with pedal steel sound. Guitar voicings are most authentic for simple chords, like major, minor, 7th, etc.
65	Country Ballad	C BALLAD	8-Beat	Especially suited to slow tempos. Also, try playing with CHORD 1 only.
66	Country Waltz	C WALTZ	Nine-Eight	Simple, versatile country style with acoustic guitar. Guitar voicings are most authentic for simple chords, like major, minor, 7th, etc.
67	Country Shuffle	C SHUFFLE	12-Beat	Traditional country style using acoustic guitar. Guitar voicings are most authentic for simple chords, like major, minor, 7th, etc.
68	Western Shuffle	W SHUFFLE	12-Beat	Down-home Country and Western shuffle, with a modern touch.
<b>World Music</b>				
69	Polka	POLKA	8-Beat	Traditional Polka style with acoustic instruments. Try altering the arrangement by bringing the accordion and the horn parts in and out.
70	Traditional Waltz	TRAD WALTZ	Three-Four	European waltz with guitar, accordion, clarinet, bass, drums and a string pad. Use CHORD 1 & 2 and PHRASE 1 for guitar/accordion arrangement.
71	Slow Waltz	SLOW WALTZ	Three-Four	This slow waltz (or English waltz) style has been arranged in the style of a small band.
72	Viennese Waltz	VIEN WALTZ	Three-Four	Relaxed, ballroom waltz. Guitar is at CHORD 1, accordion at CHORD 2, pizzicato strings at PHRASE 1, clarinets at PHRASE 2 and mid-register strings at PAD.
73	Sevillianas	SEVILLIANAS	Three-Four	Fast waltz time — almost flamenco style.
74	Bolero Lento	BOLEROLENTO	8-Beat	Guitar-based style, quite romantic. Bolero Lento is related to Rumba and can be used as a slower variation.
75	Rumba Espagnole	ESPAGNOLE	16-Beat	Spanish guitar style, with relatively full orchestration.
76	Dangdut	DANGDUT	8-Beat	Contemporary Indonesian pop sound.
77	Enka	ENKA	8-Beat	Modern arrangement of old Japanese pop style.
<b>March</b>				
78	Military March	MARCH	8-Beat	Traditional march style. Trombones at CHORD 1, trumpets at CHORD 2, french horn at PHRASE 1, piccolo at PHRASE 2, xylophone at PAD.
79	6/8 March	6/8 MARCH	Six-Eight	Marching brass band. Change chords during the drum intro to add brass accents.
80	Tarantella	TARANTELLA	Six-Eight	Named after the Tarantula spider, whose bite might cause one to dance in this style, this rhythm is used in the popular song "Funiculi Funicula."

## Reset Procedures & Page Memory Default Settings

All PSR-410 page memory settings are retained in memory even when the power switch is turned OFF as long as the PSR-410 is powered by batteries or an AC adapter. You can, however, restore the factory default settings for all four page memories or a single specified page memory by following the procedures outlined below.

### ● System Reset

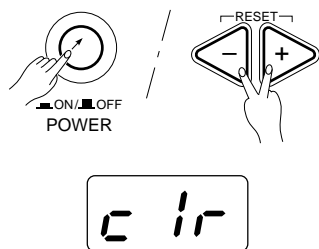

**1** Press the POWER switch to turn the PSR-410 power OFF.

**2** Turn the power back ON while holding both the [+] and [-] buttons. “clr” will appear on the MULTI DISPLAY while the data is being reset.



• Executing the System Reset function will erase any existing settings all page memory locations!

### ● Page Reset

**1** Select the PAGE MEMORY Number You Want to Reset .....

Select the PAGE MEMORY number you want to reset (page 41).

**2** Press the [MIDI BULK DUMP/PAGE COPY] Button .....

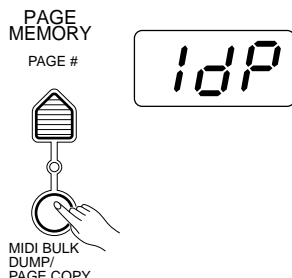

Press the [MIDI BULK DUMP/PAGE COPY] button. The “ARE YOU SURE?” indicator will flash and the PSR-410 will ask “Are you sure?”. At the same time “1dP”, “2dP”, “3dP”, or “4dP” will appear on the MULTI DISPLAY, depending on the selected PAGE MEMORY number.

**3** Select a “cL” Display .....

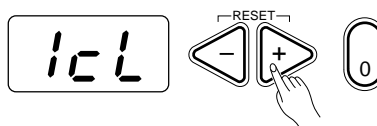

Use the [+] and [-] buttons or the data dial to select “1cL”, “2cL”, “3cL”, or “4cL” (the number corresponds to the selected page number).

**4** Press [YES] to Reset .....

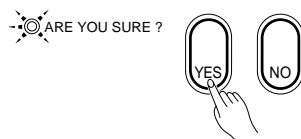

Press the [YES] button to execute the page reset function, or the [NO] button to cancel and return to the PAGE MEMORY number selection mode (step 1, above). All settings in the selected page will be reset to their initial values.

When the data has been reset the PSR-410 will automatically return to the VOICE SELECT mode.



• Executing the Page Reset function will erase any existing settings all selected page memory location!

# Appendix

## ● Page Memory Default Settings

	ORCHESTRATION	VOICE						AUTO ACCOMPANIMENT		OVERALL CONTROL				MULTI PADS			
		On/Off	VOICE No.	VOL	PAN	OCTAVE	HARMONY		STYLE No.	VOL	TEMPO	SPLIT POINT		P.B. Range	TOUCH On/Off	1/2/3/4	
							On/Off	TYPE				Split mode	Accomp.				
PAGE1	REGIST1	R1	○	01	21	0	0	Off	01	20	21	120	61	55	2	On	preset x4
		R2	×	52	21	0	0										
		L1	×	33	21	0	-1										
		L2	×	06	21	0	0										
	PERCUSS.	Off	1	21	0	-1											
	REGIST2	R1	○	06	21	0	0	Off	01	17	21	94	63	55	2	On	
		R2	○	53	21	0	-1										
		L1	○	37	21	0	-1										
		L2	×	35	21	0	-1										
	PERCUSS.	Off	1	21	0	-1											
	REGIST3	R1	○	19	21	0	0	Off	01	61	21	82	61	55	2	On	
		R2	○	18	21	0	-1										
		L1	○	35	21	0	-1										
		L2	×	33	21	0	-1										
	PERCUSS.	Off	1	21	0	-1											
	REGIST4	R1	○	57	21	2	0	Off	04	79	21	126	61	55	2	On	
R2		○	89	21	-2	-1											
L1		○	51	21	2	0											
L2		○	48	21	-2	-1											
PERCUSS.	Off	1	21	0	-1												
PAGE2	REGIST1	R1	○	63	21	3	-1	Off	01	14	21	120	61	55	2	On	
		R2	○	96	21	-3	-1										
		L1	○	88	21	0	-1										
		L2	○	64	21	0	0										
	PERCUSS.	Off	1	21	0	-1											
	REGIST2	R1	○	30	21	0	0	Off	01	30	21	180	61	55	2	On	
		R2	○	85	21	0	0										
		L1	×	86	21	0	1										
		L2	○	102	21	0	0										
	PERCUSS.	Off	1	21	0	-1											
	REGIST3	R1	○	83	21	0	0	Off	01	9	21	78	61	55	2	On	
		R2	○	123	21	0	0										
		L1	○	26	21	0	0										
		L2	○	89	21	0	0										
	PERCUSS.	Off	1	21	0	-1											
	REGIST4	R1	○	13	21	-3	-1	Off	01	55	21	108	61	55	2	On	
R2		○	115	21	3	0											
L1		×	12	21	0	1											
L2		○	33	21	0	-1											
PERCUSS.	Off	1	21	0	1												
PAGE3	REGIST1	R1	○	23	21	0	0	Off	01	64	21	130	61	55	2	On	
		R2	×	106	21	0	-1										
		L1	○	26	21	0	0										
		L2	×	04	21	0	0										
	PERCUSS.	Off	1	21	0	-1											
	REGIST2	R1	○	62	21	3	-1	Off	01	41	21	155	61	55	2	On	
		R2	○	67	21	-3	-1										
		L1	○	33	21	0	-1										
		L2	×	01	21	0	0										
	PERCUSS.	Off	1	21	0	-1											
	REGIST3	R1	○	25	21	2	-1	Off	01	74	21	102	61	55	2	On	
		R2	○	53	10	-2	-1										
		L1	○	25	21	-2	-1										
		L2	○	52	14	2	-1										
	PERCUSS.	Off	1	21	0	-1											
	REGIST4	R1	○	06	21	3	0	Off	01	16	21	112	69	55	2	On	
R2		○	05	21	2	0											
L1		○	06	21	-3	0											
L2		○	51	13	0	0											
PERCUSS.	Off	1	21	0	-1												
PAGE4	REGIST1	R1	○	20	21	4	0	Off	01	35	21	70	69	55	2	On	
		R2	○	53	21	-4	-1										
		L1	×	21	21	0	0										
		L2	×	54	21	0	1										
	PERCUSS.	Off	1	21	0	-1											
	REGIST2	R1	○	04	21	1	0	Off	01	40	21	180	69	55	2	On	
		R2	×	01	21	1	0										
		L1	×	02	21	0	0										
		L2	×	03	21	0	0										
	PERCUSS.	Off	1	21	0	-1											
	REGIST3	R1	○	62	21	3	0	Off	02	70	21	180	61	55	2	On	
		R2	○	57	21	-2	0										
		L1	○	48	21	-2	-1										
		L2	○	59	21	2	-1										
	PERCUSS.	Off	1	21	0	-1											
	REGIST4	R1	○	54	21	4	0	Off	02	21	21	102	61	55	2	On	
R2		○	92	10	1	-1											
L1		○	53	21	-4	0											
L2		○	92	10	0	-1											
PERCUSS.	Off	1	21	0	-1												

\* The song memory has no default data, so all data it contains will be erased when a reset operation is executed.

\* The default [EDIT] button indicator setting is R1.

## ■ Troubleshooting

Something not working as it should? In many cases what appears to be a malfunction can be traced to a simple error that can be remedied immediately. Before assuming that your PSR-410 is faulty, please check the following points.

PROBLEM	POSSIBLE CAUSE/SOLUTION
<ul style="list-style-type: none"> <li>The PSR-410 speakers produce a “pop” sound whenever the power is turned ON or OFF.</li> </ul>	<ul style="list-style-type: none"> <li>This is normal and is no cause for alarm.</li> </ul>
<ul style="list-style-type: none"> <li>Reduced volume</li> <li>Poor sound quality.</li> <li>Improper demo or song memory playback.</li> <li>MULTI DISPLAY has gone out and the panel setting has been set to default.</li> </ul>	<ul style="list-style-type: none"> <li>The batteries probably need to be replaced. Replace all six batteries with new ones of the same type, as described on page 5.</li> </ul>
<ul style="list-style-type: none"> <li>Not all simultaneously-played notes sound.</li> </ul>	<ul style="list-style-type: none"> <li>You are probably exceeding the maximum polyphony of the PSR-410. The PSR-410 can play up to 28 notes at the same time — including split, dual, auto-accompaniment, and multi pad notes. Notes exceeding this limit will not sound.</li> </ul>
<ul style="list-style-type: none"> <li>Auto accompaniment won't function properly. No lower keyboard sound.</li> </ul>	<ul style="list-style-type: none"> <li>Auto accompaniment won't sound right if you're using SINGLE type fingering when the SINGLE mode is not selected (page 23).</li> <li>Are you sure you're playing in the Auto-Accompaniment section of the keyboard?</li> <li>Are you playing chords that the PSR-410 can recognize (see chord types on pages 22, 23, and 24)?</li> </ul>
<ul style="list-style-type: none"> <li>The selected voice does not sound when the keyboard is played.</li> </ul>	<ul style="list-style-type: none"> <li>The orchestration part to which the voice is assigned must be turned ON (page 10).</li> <li>Make sure that the voice volume parameter for the orchestration part to which the voice is assigned is set to an appropriate level (page 13).</li> </ul>
<ul style="list-style-type: none"> <li>Voice parameter changes do not affect the desired voice.</li> </ul>	<ul style="list-style-type: none"> <li>The edit mode for the voice to which the changes are to be applied must be turned ON (page 12).</li> </ul>
<ul style="list-style-type: none"> <li>No sound when rhythm started.</li> </ul>	<ul style="list-style-type: none"> <li>Some sections of some styles have no data in the rhythm track. Try turning Auto Accompaniment on and fingering an appropriate chord. The Auto Accompaniment should begin to play.</li> </ul>
<ul style="list-style-type: none"> <li>Sustain ON/OFF status has been reversed.</li> </ul>	<ul style="list-style-type: none"> <li>Sustain ON/OFF status will be reversed when POWER is turned on with the Footswitch pressed or the footswitch is plugged in while it is being pressed. Turn POWER OFF and turn it back ON to return to normal status.</li> </ul>
<ul style="list-style-type: none"> <li>Song Memory track indicator does not go out when the track is cleared.</li> </ul>	<ul style="list-style-type: none"> <li>You may have executed the clear function from a point in the middle of the track, thus only clearing the data after that point. Press the [RESET] button to go to the beginning of the track, then clear.</li> </ul>
<ul style="list-style-type: none"> <li>MIDI bulk reception of separate data blocks fails.</li> </ul>	<ul style="list-style-type: none"> <li>When sending Song Memory, Multi Pad, and/or Registration Memory data to the PSR-410 as separate blocks from a sequencer or other MIDI device, either send all blocks in succession leaving no more than a 2-second break between blocks, or wait until the voice display appears on the PSR-410 after each block and send the blocks separately.</li> </ul>

# Index

+ and – buttons ..... 9

## A

AC power adaptor ..... 5  
Accompaniment control ..... 25  
Accompaniment track recording ..... 33  
Are you sure? ..... 9, 40, 41  
Auto accompaniment ..... 20  
Auto harmony ..... 15

## B

Batteries ..... 5  
Beat indicator ..... 25  
Bulk dump, MIDI ..... 43

## C

Cleaning ..... 4  
Clearing tracks ..... 40  
Connectors, MIDI ..... 42

## D

Demo song ..... 7  
Dual mode ..... 11

## E

Edit part selection ..... 12  
Editing procedures ..... 8  
Electrical interference ..... 4  
Ending ..... 27

## F

Fill-ins ..... 26  
Fingering modes ..... 21-24  
Function button ..... 8

## H

Harmony types ..... 15  
Headphones ..... 6

## I

Introduction (Intro) ..... 26

## K

Keyboard percussion ..... 16

## M

Main A & B sections ..... 26  
Measure number ..... 37  
Melody track recording ..... 35  
Metronome ..... 24  
MIDI ..... 42-47  
MIDI implementation chart ..... 220  
Multi pads ..... 38  
Music stand ..... 6

## N

Number buttons ..... 9

## O

Octave ..... 13  
One touch setting ..... 30  
Orchestration ..... 10  
Overall control ..... 18

## P

Page number ..... 41  
Page copy ..... 44  
Page memory ..... 41  
Page memory default settings ..... 52  
Pan ..... 14  
Panel controls (control names) ..... 2-3  
Percussion kits ..... 16  
Percussion kit list ..... 218  
Pitch bend range ..... 17  
Pitch bend wheel ..... 17  
Playback, accompaniment & melody ..... 36  
Playback, multi pad ..... 39  
Power supply ..... 4, 5

## R

Re-voice ..... 29  
Reception modes, MIDI ..... 45  
Record functions ..... 32-40  
Registration memory ..... 31  
Reset button ..... 37  
Reset procedures ..... 51

## S

Service & modification ..... 4  
Single modes ..... 10  
Song memory ..... 32  
Sound system, external ..... 6  
Split & dual modes ..... 11  
Split modes ..... 11  
Split point, orchestration ..... 18  
Split point, auto accompaniment ..... 21  
Start/stop mode, MIDI ..... 46  
Stopping accompaniment ..... 27  
Straight start ..... 25  
Style list ..... 49-50  
Style selection ..... 20  
Sustain ..... 6, 17  
Synchro start ..... 25

## T

Tempo control ..... 24  
Touch response ..... 19  
Tracks (Auto Accompaniment) ..... 28  
Transmission, MIDI ..... 47  
Transpose ..... 19  
Troubleshooting ..... 53  
Tuning ..... 19

## V

Voice & polyphony list ..... 48  
Voice assignment (Voice select) ..... 12  
Volume, accompaniment ..... 27  
Volume, master ..... 7  
Volume, voice ..... 13

# Percussion Kit List

\* “<—” indicates the content is the same as that of Standard Kit.

\* Only 1 note can be played at a time when Keyboard Percussion is engaged.

\* The number in parentheses () after the percussion kit name is the MIDI program number.

\* The corresponding MIDI note numbers for the notes listed in the chart below are actually one octave lower. For example, the MIDI note number for note #36 (C1) in the chart is note #24 (C0).

Note#	Note	1: Standard (0)	2: Room (8)	3: Rock (16)	4: Electronic (24)
36	C1	Click (Square wave)	<—	<—	<—
37	C#1	Brush Tap	<—	<—	<—
38	D1	Brush Swirl	<—	<—	<—
39	D#1	Brush Slap	<—	<—	<—
40	E1	Brush Swirl W/Attack	<—	<—	Reverse Cymbal
41	F1	Snare Roll	<—	<—	<—
42	F#1	Castanet	<—	<—	Hi-Q
43	G1	Snare H Soft	Snare Room L	Snare Rock L	Snare Gate L
44	G#1	Sticks	<—	<—	<—
45	A1	Bass Drum H Soft	Bass Drum Room L	Bass Drum Rock L	Bass Drum Gate L
46	A#1	Open Rim Shot	<—	<—	<—
47	B1	Bass Drum L	Bass Drum Room M	Bass Drum Rock M	Bass Drum Gate M
48	C2	Bass Drum H Hard	Bass Drum Room H	Bass Drum Rock H	Bass Drum Gate H
49	C#2	Closed Rim Shot	<—	<—	<—
50	D2	Snare L	Snare Room M	Snare Rock M	Snare Gate M
51	D#2	Hand Clap	<—	<—	<—
52	E2	Snare H Hard	Snare Room H	Snare Rock H	Snare Gate H
53	F2	Floor Tom L	Room Tom 1	Rock Tom 1	Electronic Tom 1
54	F#2	Hi-Hat Closed	<—	<—	<—
55	G2	Floor Tom H	Room Tom 2	Rock Tom 2	Electronic Tom 2
56	G#2	Hi-Hat Pedal	<—	<—	<—
57	A2	Low Tom	Room Tom 3	Rock Tom 3	Electronic Tom 3
58	A#2	Hi-Hat Open	<—	<—	<—
59	B2	Mid Tom L	Room Tom 4	Rock Tom 4	Electronic Tom 4
60	C3	Mid Tom H	Room Tom 5	Rock Tom 5	Electronic Tom 5
61	C#3	Crash Cymbal 1	<—	<—	<—
62	D3	High Tom	Room Tom 6	Rock Tom 6	Electronic Tom 6
63	D#3	Ride Cymbal 1	<—	<—	<—
64	E3	Chinese Cymbal	<—	<—	<—
65	F3	Ride Cymbal Cup	<—	<—	<—
66	F#3	Tambourine	<—	<—	<—
67	G3	Splash Cymbal	<—	<—	<—
68	G#3	Cowbell	<—	<—	<—
69	A3	Crash Cymbal 2	<—	<—	<—
70	A#3	Vibraslap	<—	<—	<—
71	B3	Ride Cymbal 2	<—	<—	<—
72	C4	Bongo H	<—	<—	<—
73	C#4	Bongo L	<—	<—	<—
74	D4	Conga H Mute	<—	<—	<—
75	D#4	Conga H Open	<—	<—	<—
76	E4	Conga L	<—	<—	<—
77	F4	Timbale H	<—	<—	<—
78	F#4	Timbale L	<—	<—	<—
79	G4	Agogo H	<—	<—	<—
80	G#4	Agogo L	<—	<—	<—
81	A4	Cabasa	<—	<—	<—
82	A#4	Maracas	<—	<—	<—
83	B4	Samba Whistle H	<—	<—	<—
84	C5	Samba Whistle L	<—	<—	<—
85	C#5	Guiro Short	<—	<—	<—
86	D5	Guiro Long	<—	<—	<—
87	D#5	Claves	<—	<—	<—
88	E5	Wood Block H	<—	<—	<—
89	F5	Wood Block L	<—	<—	<—
90	F#5	Cuica Mute	<—	<—	Scratch H
91	G5	Cuica Open	<—	<—	Scratch L
92	G#5	Triangle Mute	<—	<—	<—
93	A5	Triangle Open	<—	<—	<—
94	A#5	Shaker	<—	<—	<—
95	B5	Jingle Bell	<—	<—	<—
96	C6	Bell Tree	<—	<—	<—
97	C#6	Voice 'One'	<—	<—	<—
98	D6	Voice 'Two'	<—	<—	<—
99	D#6	Voice 'Three'	<—	<—	<—
100	E6	Voice 'Four'	<—	<—	<—
101	F6	Voice 'Are You Sure?'	<—	<—	<—

Note#	Note	5: Analog (25)	6: Jazz (32)	7: Brush (40)	8: Classic (48)
36	C1	<—	<—	<—	<—
37	C#1	<—	<—	<—	<—
38	D1	<—	<—	<—	<—
39	D#1	<—	<—	<—	<—
40	E1	Reverse Cymbal	<—	<—	<—
41	F1	<—	<—	<—	<—
42	F#1	Hi-Q	<—	<—	<—
43	G1	Snare Analog L	<—	Brush Slap L	Snare Classic L
44	G#1	<—	<—	<—	<—
45	A1	Bass Drum Analog L	<—	<—	Gran Casa L
46	A#1	<—	<—	<—	<—
47	B1	Bass Drum Analog M	<—	<—	Gran Casa M
48	C2	Bass Drum Analog H	<—	<—	Gran Casa H
49	C#2	Closed Rim Shot Analog	<—	<—	<—
50	D2	Snare Analog M	<—	Brush Slap H	Snare Classic M
51	D#2	<—	<—	<—	<—
52	E2	Snare Analog H	<—	Brush Tap	Snare Classic H
53	F2	Analog Tom 1	Natural Tom 1	Brush Tom 1	Natural Tom 1
54	F#2	Analog Hi-hat Closed 1	Dark Hi-Hat Closed	Dark Hi-Hat Closed	Dark Hi-Hat Closed
55	G2	Analog Tom 2	Natural Tom 2	Brush Tom 2	Natural Tom 2
56	G#2	Analog Hi-hat Closed 2	Dark Hi-Hat Pedal	Dark Hi-Hat Pedal	Dark Hi-Hat Pedal
57	A2	Analog Tom 3	Natural Tom 3	Brush Tom 3	Natural Tom 3
58	A#2	Analog Hi-hat Open	Dark Hit Hat Open	Dark Hit Hat Open	Dark Hit Hat Open
59	B2	Analog Tom 4	Natural Tom 4	Brush Tom 4	Natural Tom 4
60	C3	Analog Tom 5	Natural Tom 5	Brush Tom 5	Natural Tom 5
61	C#3	<—	<—	<—	Hand Cymbal Long L
62	D3	Analog Tom 6	Natural Tom 6	Brush Tom 6	Natural Tom 6
63	D#3	<—	<—	<—	Hand Cymbal Short L
64	E3	<—	<—	<—	<—
65	F3	<—	<—	<—	<—
66	F#3	<—	<—	<—	<—
67	G3	<—	<—	<—	<—
68	G#3	<—	<—	<—	<—
69	A3	<—	<—	<—	Hand Cymbal Long H
70	A#3	<—	<—	<—	<—
71	B3	<—	<—	<—	Hand Cymbal Short H
72	C4	<—	<—	<—	<—
73	C#4	<—	<—	<—	<—
74	D4	<—	<—	<—	<—
75	D#4	<—	<—	<—	<—
76	E4	<—	<—	<—	<—
77	F4	<—	<—	<—	<—
78	F#4	<—	<—	<—	<—
79	G4	<—	<—	<—	<—
80	G#4	<—	<—	<—	<—
81	A4	<—	<—	<—	<—
82	A#4	<—	<—	<—	<—
83	B4	<—	<—	<—	<—
84	C5	<—	<—	<—	<—
85	C#5	<—	<—	<—	<—
86	D5	<—	<—	<—	<—
87	D#5	<—	<—	<—	<—
88	E5	<—	<—	<—	<—
89	F5	<—	<—	<—	<—
90	F#5	Scratch H	<—	<—	<—
91	G5	Scratch L	<—	<—	<—
92	G#5	<—	<—	<—	<—
93	A5	<—	<—	<—	<—
94	A#5	<—	<—	<—	<—
95	B5	<—	<—	<—	<—
96	C6	<—	<—	<—	<—
97	C#6	<—	<—	<—	<—
98	D6	<—	<—	<—	<—
99	D#6	<—	<—	<—	<—
100	E6	<—	<—	<—	<—
101	F6	<—	<—	<—	<—

# MIDI Implementation Chart

[Portable Keyboard]

Model: PSR-410

## MIDI Implementation Chart

Date: 1993. 6. 15

Version: 1.00

Function	Transmitted	Recognized	Remarks
Basic Default Channel Changed	1~16 CH 1~16 CH	1~16 CH (*1) 1~16 CH (*1)	
Mode Default Messages Altered	Mode 3 × *****	(*1) × ×	
Note Number : True voice	0~127 *****	0~127 0~127	
Velocity Note on Note off	○ 9nH, v=1~127 × 9nH, v=0	○ 9nH, v=1~127 × 9nH, v=0 or 8nH	
After key's Touch Ch's	× ×	× ○ (*2)	
Pitch Bender	○	○	
Control Change	0, 32 ○ (*3) 1 × 6, 38 ○ 7 ○ 10 ○ 11 ○ 64 ○ 66 × 84 ○ 90 × 91 ○ 96 × 97 × 100, 101 ○ (*6) 120 ○ 121 ×	○ (*4) ○ ○ ○ ○ ○ ○ ○ ○ (*5) ○ ○ ○ ○ (*7) ○ ○ (*8)	Bank select MSB, LSB Modulation depth Data entry MSB, LSB Volume Pan Expression Sustain Sostenuto Portamento control  Reverb send level RPN data increment RPN data decrement RPN MSB, LSB All sound off Reset all controllers
Program Change : True #	○ 0~127 *****	○ 0~127 0~127 (*9)	
System Exclusive	○ (*10)	○ (*10)	
System : Song Position : Song Select Common : Tune	× × ×	× × ×	
System : Clock Real Time : Commands	○ ○ (*12)	○ (*11) ○ (*12)	
Aux : Local ON/OFF : All Notes Off Messages : Active Sense : Reset	× ○ ○ ×	× ○ ○ ×	

Mode 1: OMNI ON, POLY  
Mode 3: OMNI OFF, POLY

Mode 2: OMNI ON, MONO  
Mode 4: OMNI OFF, MONO

○: Yes  
×: No

\*1. The following modes can be set individually for each channel via the panel control:

- Mode 00: Reception OFF.
- Mode 01: Direct tone generator control.
- Mode 02: Same as keyboard note on/off operation.
- Mode 03: Same as auto-accompaniment chord fingering.
- Mode 04: Same as the lowest-note (bass note) played in the auto-accompaniment chord fingering.

\*2. Channel pressure handled as vibrato.

\*3. For bank selection transmission only the MSB changes. The LSB is fixed at 00H.

\*4. Bank select reception.

The bank select MSB is used for melody voice and rhythm voice switching.

The bank select LSB is ignored.

MSB 00H: GM melody voice.

MSB 7FH: GM rhythm voice.

The default for all the channels excepting channel 10 is 00H. Bank select reception with channel 10 is not possible since channel 10 is assigned to the rhythm accompaniment. However, bank select reception with channel 10 will be possible when you do the following operation: turning the POWER back on while holding the C1 key down.

When the bank select MSB is 01H ... 7EH, all subsequent key-ons received will be ignored.

No voice change will occur when only a bank select is received.

When a program change is received the latest bank select value is used.

\*5. Portamento control is effective only when Reception is set in the Multi mode.

\*6. A pitch bend sensitivity message is transmitted when a panel pitch bend range setting is made.

Pitch bend sensitivity: BnH, 64H, 00H, 65H, 00H

\*7. RPN receives the following data:

Pitch bend sensitivity: BnH, 64H, 00H, 65H, 00H  
Default: 02H, 00H

Fine tuning: BnH, 64H, 01H, 65H, 00H  
Default: 40H, 00H

Coarse tuning: BnH, 64H, 02H, 65H, 00H  
Default: 40H, 00H

Null: BnH, 64H, 7FH, 65H, 7FH

\*8. Reset all controllers.

Pitch bend, channel pressure, modulation, expression, sustain, and sostenuto are returned to their default values.

All RPN data is set to NULL.

Portamento is reset.

\*9. GM melody voices 0 through 127 become panel voices 1 through 128.

Rhythm voices 0, 8, 16, 24, 25, 32, 40, and 48 become panel voices 1 through 8.

\*10. Exclusive.

<GM1 System ON> F0H, 7EH, 7FH, 09H, 01H, F7H  
All parameters except MIDI Master Tuning are reset to their default values.

<MIDI Master Volume> F0H, 7FH, 7FH, 04H, 01H, ll, mm, F7H  
Allows the volume of all channels to be changed simultaneously (universal system exclusive).  
mm is used as the MIDI Master Volume value (ll is ignored).  
The default value for mm is 7FH.  
This message is receive-only.

<MIDI Master Tuning>  
F0H, 43H, 1nH, 27H, 30H, 00H, 00H, mm, ll, cc, F7H  
Allows the pitch of all channels to be changed simultaneously (panel tuning).  
mml is used as the MIDI Master Tuning value, and the actual tuning is shown by the expression:

$T = M \times 200 / 256 - 100$

Where T is the actual tuning value in cents. M is decimal value represented by 1-byte using bits 0...3 of mm as the MSB and bits 0...3 of ll as the LSB.

The default values of mm and ll are 07H and 0FH, respectively.  
n and cc are also recognized.

This value is not reset by a GM System ON or Reset All Controllers message.

This message is transmitted and received.

<Bulk Dump>

bl and bh represent the total byte count as bl+bh\*128.

CS: Checksum.

Multi pad: F0H, 43H, 76H, 12H, bl, bh, <Data>, cs, F7H

Song memory: F0H, 43H, 76H, 16H, bl, bh, <Data>, cs, F7H

Registration memory: F0H, 43H, 76H, 14H, bl, bh, <Data>, cs, F7H

<Panel Control>

Dual data change: F0H, 43H, 76H, 17H, 04H, <Data>, F7H

Dual ON/OFF: F0H, 43H, 76H, 17H, 05H, <Data>, F7H

Harmony: F0H, 43H, 76H, 17H, 0EH, <Data>, F7H

Chord/Bass: F0H, 43H, 76H, 17H, 0BH, <Data>, F7H

\*11. Internal/external clock selectable.

\*12. Operation when a start/stop command is received is determined by the RECEIVE CHANNEL, CLOCK, AND COMMAND panel settings.

0. Start/stop command ignored.

1. Auto-accompaniment start/stop.

2. Song memory start/stop.

Continue neither transmitted nor received.

## ■ GM System Level 1

The existing MIDI protocol allows performance and other data to be transferred between different instruments, even if they are from different manufacturers. This means, for example, that sequence data that was originally created to control a tone generator from manufacturer A can also be used to control a different tone generator from manufacturer B. Since the voice allocation in different devices from different manufacturers is usually different, however, appropriate program change data must be transmitted to select the right voices.

The General MIDI protocol was developed to minimize confusion and the need for re-programming when playing software created by one MIDI device on another. This has been achieved by defining a standard voice allocation in which the same or similar voices are accessed by the same program change numbers or MIDI channels. The current standard recognized by the International MIDI Association is known as "GM System Level 1." The PSR-410 voice allocation complies with the GM System Level 1 standard.

# Specifications

## Keyboards:

61 standard-size keys (C1~C6) with touch response.

## VOICE:

AWM128 voices: 01~128

Polyphony: 28

KEYBOARD PERCUSSION: 1~8

VOL: 00~24

OCTAVE: -2~2

PAN: -7~7

ONE TOUCH SETTING

ORCHESTRATION: R1/R2/L1/L2

HARMONY: TYPE 01~10, ON/OFF

## Setup:

POWER: ON/OFF

MASTER VOLUME: MIN~MAX

## PAGE MEMORY:

PAGE #: 1~4

MIDI BULK DUMP/PAGE COPY

## OVERALL CONTROL:

TEMPO: 040~240

METRONOME: ON/OFF

SPLIT POINT

TRANPOSE: -12~12

TUNING: -16~16

TOUCH RESPONSE ON/OFF

PITCH BEND: -12~12

## AUTO ACCOMPANIMENT:

80 styles

AUTO ACCOMP: ON/OFF

FINGERING: 1~5

ACCOMP VOLUME: 00~24

REVOICE

TRACK: RHYTHM 1/2, BASS, RHYTHMIC CHORD 1/2,

PAD CHORD, PHRASE 1/2

ACCOMPANIMENT CONTROL: SYNC-START/STOP,

START/STOP, INTRO, FILL IN 1, FILL IN 2, ENDING,

MAIN A/B

## REGISTRATION MEMORY:

MEMORIZE

1~4

## MULTI PADS:

STOP

1~4 (including 2 chord-match types).

## DEMO:

SONG #: ALL, 1~5

START/STOP

## SONG MEMORY:

MEASURE #

TRACK: ACCOMP, MELODY

## SONG:

RESET, PLAY/STOP

## RECORDING:

REC, CLEAR

## ARE YOU SURE ?:

YES, NO

## MULTI DISPLAY:

Number Buttons: [+], [-], [0]~[9], [+/-]

## MIDI:

RECEIVE CH/CL/COM, TRANSMIT CH

## Auxiliary Jacks:

DC IN, HEADPHONES/AUX OUT, SUSTAIN PEDAL,

MIDI IN/OUT

## Main Amplifiers:

4.5W x 2 (when using PA-5 AC power adaptor)

1.5W x 2 (when using batteries)

HEADPHONES/AUX OUT output: 75Ω impedance.

## Speakers:

12cm (4-3/4") x 2

## Batteries:

Six SUM-1, "D" size, R-20 or equivalent batteries

## Rated Voltage:

DC 10-12V

## Dimensions (W x D x H):

939mm x 397mm x 113mm (37" x 15-5/8" x 4-1/2")

## Weight:

6.0kg (13.2 lbs.) excluding batteries

## Supplied Accessories:

- Music Stand
- Owner's Manual

## Optional Accessories:

- Headphones HPE-3, HPE-150
- Keyboard Stand L-2C
- AC Power Adaptor PA-3, PA-4, PA-5, PA-5B, PA-40
- Foot switch FC4, FC5

\* Specifications subject to change without notice.