

# *IES-5000 Series*

*Integrated Ethernet Switch*

## ***User's Guide***

Version 3.01  
8/2007  
Edition 1





# About This User's Guide

## Intended Audience

This manual is intended for people who want to install and maintain the IES-5000 series Integrated Ethernet Switch. This User's Guide gives hardware installation, connection and maintenance instructions. It also gives specifications.

## Related Documentation

- Line Card User's Guides

These User's Guides provide hardware connection details and explain how to configure and manage the individual line cards.

- Management Switch Card User's Guide

This User's Guide provides hardware connection details, and configuration and management instructions for the management switch card.

- Supporting Disk

Refer to the included CD for support documents.

- ZyXEL Web Site

Please refer to [www.zyxel.com](http://www.zyxel.com) for additional support documentation and product certifications.

## User Guide Feedback

Help us help you. Send all User Guide-related comments, questions or suggestions for improvement to the following address, or use e-mail instead. Thank you!

The Technical Writing Team,  
ZyXEL Communications Corp.,  
6 Innovation Road II,  
Science-Based Industrial Park,  
Hsinchu, 300, Taiwan.

E-mail: [techwriters@zyxel.com.tw](mailto:techwriters@zyxel.com.tw)

# Document Conventions

## Warnings and Notes

These are how warnings and notes are shown in this User's Guide.



---

Warnings tell you about things that could harm you or your device.

---



---

Notes tell you other important information (for example, other things you may need to configure or helpful tips) or recommendations.

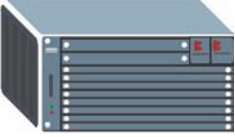






---

## Syntax Conventions

- The IES-5000 or IES-5005 may be referred to as the “IES-5000”, the “IES”, or the “main chassis”. Differentiation is made where needed.
- Unless otherwise specified, IES-5000 refers to the IES-5000 or IES-5005 main chassis and its cards along with the IES-5000 or IES-5005 splitter chassis and its cards.
- The IES-5000M is the IES-5000 main chassis.
- The IES-5005M is the IES-5005 main chassis.
- The IES-5000ST is the IES-5000 splitter chassis with Telco-50 connectors.
- The IES-5005ST is the IES-5005 splitter chassis with Telco-50 connectors.
- The MSC1024G (Management Switch Card) may be referred to as the “management card” or the “MSC”.
- The ALC1248G-51, ALC1248G-53, ALC1272G (ADSL Line Cards), SLC1248G-22 (SHDSL Line Card), VLC1224G-41 (VDSL Line Card) and VOP1248G-61 (VoIP Line Card) may be collectively referred to as the “line cards”.
- The ALC1248G-51 for ADSL over POTS (Annex A) Line Card may be referred to as the “ALC1248G”, the “ALC” or the “line card” in this User's Guide.
- The ALC1248G-53 for ADSL over ISDN (Annex B) Line Card may be referred to as the “ALC1248G”, the “ALC” or the “line card” in this User's Guide.
- The ALC1272G ADSL2/2+ Line Card may be referred to as the “ALC1272G”, the “ALC” or the “line card” in this User's Guide.
- The SLC1248G-22 (SHDSL Line Card) may be individually referred to as the “SLC”.
- The VLC1224G-41 (VDSL Line Card) may be individually referred to as the “VLC”.
- The VOP1248G-61 (VoIP Line Card) may be individually referred to as the “VOP”.
- “IES” refers to the main chassis and its cards, along with the splitter chassis and its cards.

## Icons Used in Figures

Figures in this User's Guide may use the following generic icons. The IES-5000 icon is not an exact representation of your device.

IES-5000 	Computer 	Notebook computer 
Server 	Telephone 	
Switch 	Router 	

# Safety Warnings



---

For your safety, be sure to read and follow all warning notices and instructions.

---

- Do NOT use this product near water, for example, in a wet basement or near a swimming pool.
- Do NOT expose your device to dampness, dust or corrosive liquids.
- Do NOT store things on the device.
- Do NOT install, use, or service this device during a thunderstorm. There is a remote risk of electric shock from lightning.
- Connect ONLY suitable accessories to the device.
- ONLY qualified service personnel should service or disassemble this device.
- Make sure to connect the cables to the correct ports.
- Place connecting cables carefully so that no one will step on them or stumble over them.
- Always disconnect all cables from this device before servicing or disassembling.
- Use ONLY power wires of the appropriate wire gauge for your device. Connect it to a power supply of the correct voltage (see [Appendix A on page 75](#) for details).
- Do NOT allow anything to rest on the power adaptor or cord and do NOT place the product where anyone can walk on the power adaptor or cord.
- Do NOT use the device if the power adaptor or cord is damaged as it might cause electrocution.
- If the power adaptor or cord is damaged, remove it from the device and the power source.
- Do NOT attempt to repair the power adaptor or cord. Contact your local vendor to order a new one.
- Do not use the device outside, and make sure all the connections are indoors. There is a remote risk of electric shock from lightning.
- **CAUTION: RISK OF EXPLOSION IF BATTERY (on the motherboard) IS REPLACED BY AN INCORRECT TYPE. DISPOSE OF USED BATTERIES ACCORDING TO THE INSTRUCTIONS.** Dispose them at the applicable collection point for the recycling of electrical and electronic equipment. For detailed information about recycling of this product, please contact your local city office, your household waste disposal service or the store where you purchased the product.
- Do NOT obstruct the device ventilation slots, as insufficient airflow may harm your device.
- Keep the air filters clean in order to ensure sufficient airflow.
- Use only No. 26 AWG (American Wire Gauge) or larger telecommunication line cord.
- Fuse Warning! Replace a fuse only with a fuse of the same type and rating.
- Always cover empty slots with slot covers, to ensure sufficient airflow and reduce the danger of electric shock.

- Warning! To avoid risk of electric shock, remove only one card at a time and do not place fingers or objects inside the chassis.
- The length of exposed (bare) power wire should not exceed 10mm.
- Fan Module Warning! Use the fan module handle when pulling out or pushing in the fan module. Be careful not to put fingers or objects inside the fan module.

This product is recyclable. Dispose of it properly.





# Contents Overview

- Introduction ..... 19**
  - System Introduction ..... 21
- Installation and Connections ..... 25**
  - Hardware Installation and Connections ..... 27
- Maintenance and Troubleshooting ..... 63**
  - Maintenance ..... 65
  - Hardware Troubleshooting ..... 69
- Appendices and Index ..... 73**



# Table of Contents

<b>About This User's Guide .....</b>	<b>3</b>
<b>Document Conventions.....</b>	<b>4</b>
<b>Safety Warnings.....</b>	<b>6</b>
<b>Contents Overview .....</b>	<b>9</b>
<b>Table of Contents.....</b>	<b>11</b>
<b>List of Figures .....</b>	<b>15</b>
<b>List of Tables.....</b>	<b>17</b>
<b>Part I: Introduction.....</b>	<b>19</b>
<b>Chapter 1</b>	
<b>System Introduction .....</b>	<b>21</b>
1.1 System Description .....	21
1.2 Applications .....	21
1.2.1 MTU Application .....	21
1.2.2 Central Office Application .....	22
1.3 Front Panel .....	22
<b>Part II: Installation and Connections.....</b>	<b>25</b>
<b>Chapter 2</b>	
<b>Hardware Installation and Connections .....</b>	<b>27</b>
2.1 General Installation Instructions .....	27
2.2 Chassis Installation .....	27
2.2.1 Rack-mounted Installation Requirements .....	27
2.2.2 Mounting the IES-5000 Chassis on a Rack .....	28
2.2.3 Connecting the Frame Ground .....	29
2.3 Card Installation .....	30
2.3.1 Installing MSC and Line Cards .....	30
2.3.2 Removing MSC and Line Cards .....	32
2.3.3 Installing a Splitter Chassis Card .....	33

2.3.4 Removing a Splitter Chassis Card .....	35
2.4 Making Card Connections .....	36
2.4.1 48-port Line Card Connections .....	36
2.4.2 IES-5000 72-port Line Card Connections .....	38
2.4.3 IES-5005 72-port Line Card Connections .....	41
2.4.4 VoIP Line Card Telco-50 Connections .....	42
2.4.5 Splitter Chassis Rear Panel Connections (DSL) .....	43
2.4.6 Splitter Chassis Rear Panel Connections (VoIP) .....	43
2.5 MDF Connections .....	44
2.5.1 MDF Connections Overview .....	44
2.5.2 MDF (Main Distribution Frame) .....	44
2.5.3 Telco-50 Cables .....	45
2.5.4 MDF Connections .....	46
2.5.5 VoIP Connection Scenarios .....	51
2.6 Power Connections .....	53
2.6.1 Power Modules .....	53
2.6.2 Procedure to Connect the Power: IES-5000M .....	56
2.6.3 Procedure to Connect the Power: IES-5005M .....	59
<b>Part III: Maintenance and Troubleshooting .....</b>	<b>63</b>
<b>Chapter 3</b>	
<b>Maintenance .....</b>	<b>65</b>
3.1 Fan Maintenance .....	65
3.1.1 Procedure to Remove and Install the Fan Module .....	65
3.2 Power Maintenance .....	66
3.2.1 Procedure to Disconnect the Power .....	66
3.2.2 Procedure to Change a Power Module .....	66
3.2.3 Procedure to Reconnect the Power .....	67
<b>Chapter 4</b>	
<b>Hardware Troubleshooting .....</b>	<b>69</b>
4.0.1 The PWR LED Does Not Turn On .....	69
4.0.2 The ALM LED Is On .....	69
4.0.3 No Voice on an ADSL Connection .....	70
4.0.4 No Voice on a VoIP Connection .....	70
4.0.5 Testing Wiring .....	70
<b>Part IV: Appendices and Index .....</b>	<b>73</b>

Appendix A System Specifications ..... 75

Appendix B Legal Information ..... 79

Appendix C Customer Support..... 83

**Index..... 89**



# List of Figures

Figure 1 MTU Application .....	22
Figure 2 Central Office Application Example .....	22
Figure 3 IES-5000M Front Panel .....	23
Figure 4 Chassis Airflow .....	28
Figure 5 Rack Mounting the Chassis .....	29
Figure 6 Chassis Frame Ground .....	30
Figure 7 Installing a Card .....	31
Figure 8 Closing the Ejector Levers .....	31
Figure 9 Tightening Card Thumbscrews .....	32
Figure 10 Loosening Card Thumbscrews .....	32
Figure 11 Opening the Ejector Levers .....	33
Figure 12 Removing a Main Chassis Card .....	33
Figure 13 Installing a Splitter Chassis Card .....	34
Figure 14 Tightening Splitter Chassis Card Thumbscrews .....	34
Figure 15 Loosening Splitter Chassis Card Thumbscrews .....	35
Figure 16 Removing a Splitter Chassis Card .....	36
Figure 17 IES-5000 Front Panel Telco-50 Connections (with 6 Line Cards) .....	37
Figure 18 IES-5005 Front Panel Telco-50 Connections (with 4 Line Cards) .....	38
Figure 19 IES-5000 Front Panel Telco-50 Connections (with 72-port Line Cards) .....	39
Figure 20 IES-5005 Front Panel Telco-50 Connections (with 72-port Line Cards) .....	41
Figure 21 DSL and VoIP Front Panel Telco-50 Connections (2 Splitter Chassis) .....	43
Figure 22 DSL and VoIP Rear Panel Telco-50 Connections (2 Splitter Chassis) .....	44
Figure 23 MDF (Main Distribution Frame) Wiring .....	45
Figure 24 Telco-50 Cable with RJ-11 Connectors .....	46
Figure 25 Installation Overview Example .....	46
Figure 26 Installation Scenario A .....	47
Figure 27 One MDF for End-user and CO Connections .....	48
Figure 28 Installation Scenario B .....	48
Figure 29 Two Separate MDFs for End-user and CO Connections .....	49
Figure 30 Installation Scenario C .....	50
Figure 31 VoIP Connection Scenario A .....	51
Figure 32 VoIP Connection Scenario B .....	52
Figure 33 Original Power Module (IES-5000M) .....	54
Figure 34 Newer Power Module (IES-5000M) .....	54
Figure 35 Original Power Module (IES-5005M) .....	55
Figure 36 Newer Power Module (IES-5005M) .....	55
Figure 37 Removing a Power Module (IES-5000M) .....	57
Figure 38 Inserting Power Wires (IES-5000M) .....	57

Figure 39 Tightening Power Module Screws (IES-5000M) ..... 58  
Figure 40 Power Connected (IES-5000M) ..... 58  
Figure 41 Removing the Power Block (IES-5005M) ..... 59  
Figure 42 Inserting Power Wires (IES-5005M) ..... 60  
Figure 43 Tightening Power Module Screws (IES-5005M) ..... 60  
Figure 44 Replacing Power Block (IES-5005M) ..... 60  
Figure 45 Power Connected (IES-5005M) ..... 61  
Figure 46 IES-5000 Fan Module Thumbscrews ..... 66  
Figure 47 IES-5000 Power Module ..... 67  
Figure 48 Testing In-house Wiring ..... 71

---

# List of Tables

Table 1 72-port Line Card Connections .....	40
Table 2 IES-5005M 72-port Line Card Connections .....	42
Table 3 Power Module Differences (IES-5000M) .....	55
Table 4 Power Module Differences (IES-5005M) .....	56
Table 5 SYS LED Troubleshooting .....	69
Table 6 ALM LED Troubleshooting .....	69
Table 7 Voice Troubleshooting .....	70
Table 8 Testing Wiring .....	71
Table 9 Features .....	75



---

# PART I

# Introduction

---

System Introduction (21)



# System Introduction

This chapter describes the system features, specifications and applications of the IES-5000 series.

## 1.1 System Description

The IES-5000 series are IP-based DSLAMs (Internet Protocol Digital Subscriber Line Access Multiplexer) that connect subscribers to the Internet. As a high-performance but yet compact and versatile platform, they can conveniently give telephone company central offices and Internet Service Providers (ISPs) the ability to deliver broadband Internet access and voice services to subscribers.

The IES-5000 platform allows for convenient management and support of various technologies. The IES-5000M chassis can hold a maximum of eight line cards, so up to 384 subscribers (576 when using the ALC1272 72-port line card) can simultaneously utilize a wide range of powerful broadband services. Additionally, the line cards are hot-swappable; thus, you do not need to interrupt the service of other cards to change or service an individual card. A single management switch card can provide the convenience of centralized network traffic supervision.

The IES-5000 also has dual, hot-swappable power modules that reduce the chance of system shutdown.

## 1.2 Applications

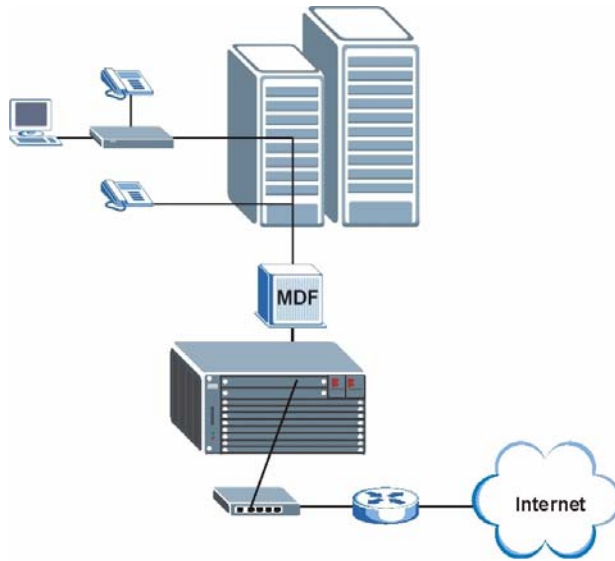
These are the main applications for the IES-5000:

- Internet access, voice over IP and multimedia services for Multiple Tenant Units (MTU).
- Other applications include video services, telemedicine, surveillance systems, remote servers systems, cellular base stations and high-quality videoconferencing.

### 1.2.1 MTU Application

The following diagram depicts a typical application of the IES-5000 in a large residential building, or multiple tenant unit (MTU), that leverages existing phone line wiring to provide voice service and Internet access to all tenants (with DSL modems). The MDF is the point of termination for the outside telephone company lines coming into a building and the telephone wiring in the building. Note that ADSL/VDSL service can coexist with voice service on the same line.

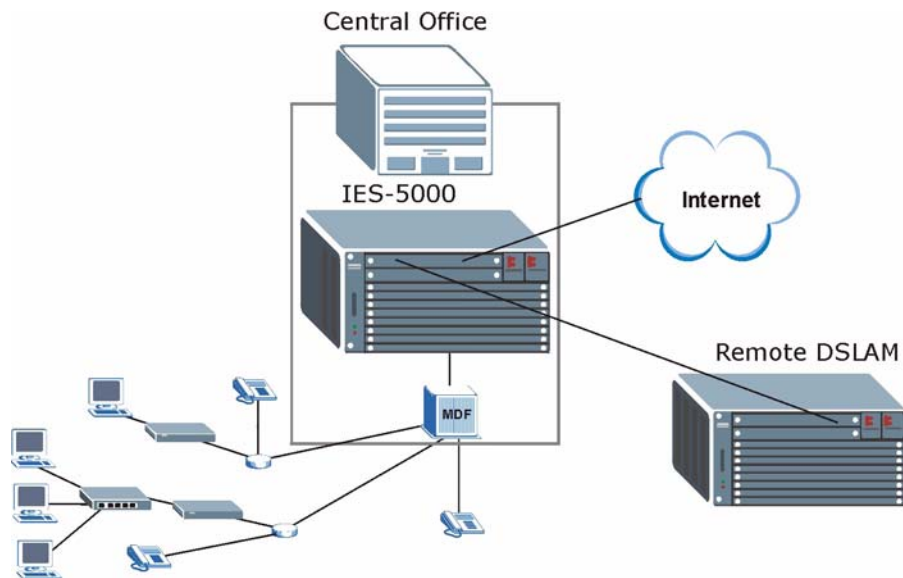
**Figure 1** MTU Application



## 1.2.2 Central Office Application

The IES-5000 provides DSL and voice service over telephone wires to subscribers. The following figure shows the IES-5000 set up in a telephone company's central office.

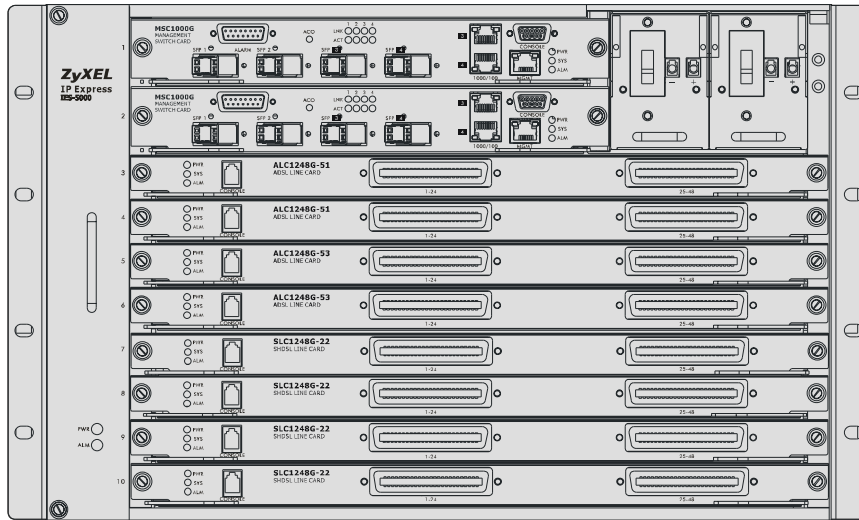
**Figure 2** Central Office Application Example



## 1.3 Front Panel

The following figures show the front panel of the IES-5000 main chassis with cards installed.

Figure 3 IES-5000M Front Panel





---

# **PART II**

# **Installation and Connections**

---

Hardware Installation and Connections (27)



# Hardware Installation and Connections

This chapter describes how to install and connect the IES-5000 chassis and cards.

## 2.1 General Installation Instructions

Perform the installation as follows:

- Make sure the IES-5000's power switches are in the **OFF** position.
- Install the chassis as detailed in this chapter. Make sure you connect the frame grounds before you make any other connections.
- If chassis cards are not already installed, follow the procedure in the next section to install them.
- Refer to [Section 2.5 on page 44](#) for instructions on making connections with Telco-50 connectors.
- Refer to [Section 2.6 on page 53](#) for instructions on making power connections and turning on the IES-5000.

## 2.2 Chassis Installation

This section explains how to install the chassis.

### 2.2.1 Rack-mounted Installation Requirements

Make sure the rack will safely support the combined weight of all the equipment it contains.



---

**Make sure the position of the IES-5000 does not make the rack unstable or top-heavy. Take all necessary precautions to anchor the rack securely before installing the unit.**

---

- Use a #2 Phillips screwdriver to install the screws.
- Refer to [Appendix A on page 75](#) for the gauge of wire to use for the frame ground connections, as well as the IES-5000 chassis' dimensions, weight and power consumption.

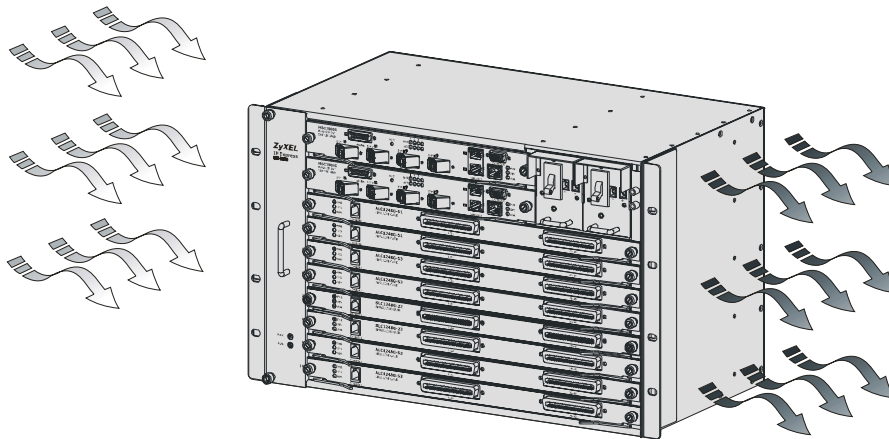


Failure to use the proper screws may damage the unit.

## 2.2.2 Mounting the IES-5000 Chassis on a Rack

- Make sure that nothing obstructs the airflow of the chassis.
- If you are facing the IES-5000 chassis front panel, the fan exhaust vents are located on the right side panel of the unit and the fans along with the intake vents are located on the left side panel.

**Figure 4** Chassis Airflow



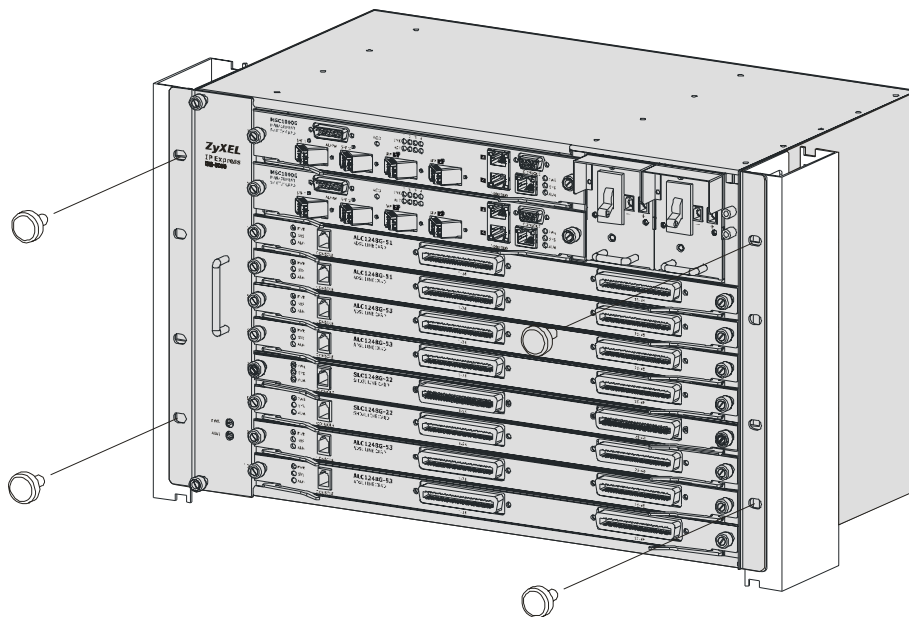
Use the following procedure to install the chassis in the rack.



Install the main chassis and splitter chassis in a rack with the splitter chassis directly below the main chassis.

- 1** Position a mounting bracket (that is already attached to the chassis) on one side of the rack, lining up the screw holes on the bracket with the screw holes on the side of the rack.
- 2** Use the screwdriver to install the screws through the mounting bracket holes into the rack.
- 3** Repeat Step 1 and Step 2 to attach the second mounting bracket on the other side of the rack.

Figure 5 Rack Mounting the Chassis



### 2.2.3 Connecting the Frame Ground

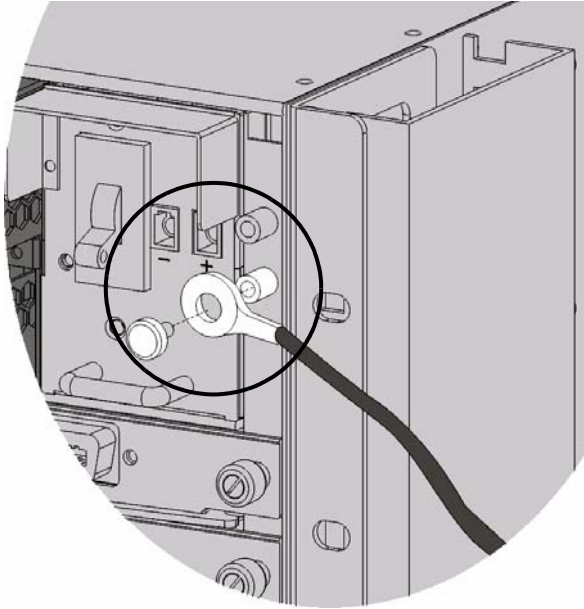
Refer to [Appendix A on page 75](#) for the ground wire gauge.

- The IES-5000 chassis frame ground is on the upper right corner of the front panel.
- Connect the frame grounds to a building's protective earthing terminals using a green-and-yellow frame ground wire.



**Warning!** Connect the frame ground before you connect any other cables or wiring.

**Figure 6** Chassis Frame Ground



## 2.3 Card Installation

This section shows you how to install and remove chassis cards.

- Install the line cards in the IES-5000 starting from slot 3 downwards.
- Install the line cards in the IES-5005 starting from slot 2 downwards.
- Install management switch cards in slot 1 and/or 2 on the IES-5000.
- Install a management switch card in slot 1 on the IES-5005.

### 2.3.1 Installing MSC and Line Cards

Use the following procedure to install management switch cards and line cards in the chassis.

- 1** Grasp the center of the front panel of the card with one hand and place the other hand under the card to support it.
- 2** Insert the card halfway into the slot and spread the two ejector levers outward. Make sure the ejector levers are perpendicular to the front panel.
- 3** Slide the card into the slot until it makes contact with the backplane. The ejector levers should be at a small angle to the front panel now.
- 4** Push the two ejector levers firmly until they are flush with the front panel.
- 5** Tighten the two thumbscrews.

Figure 7 Installing a Card

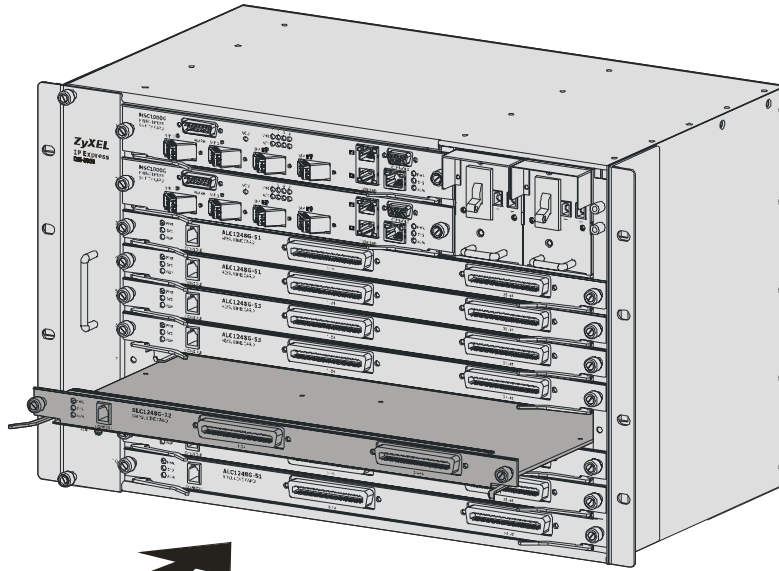
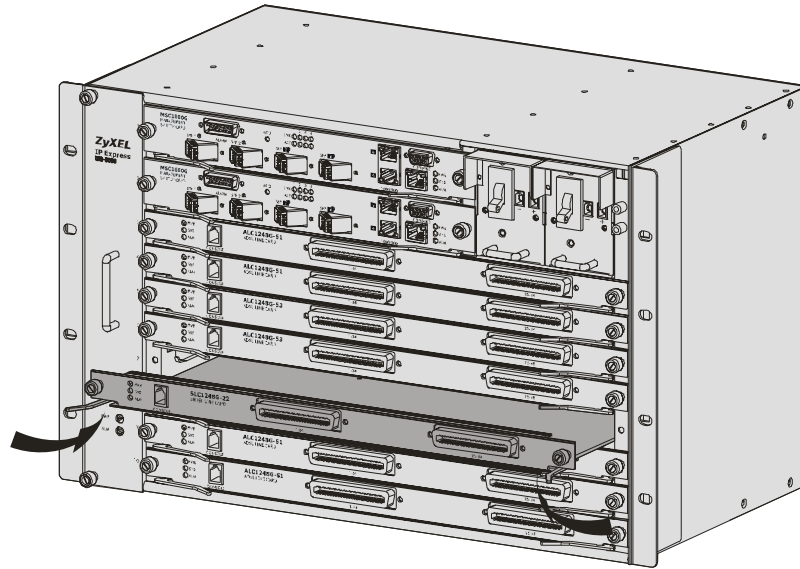
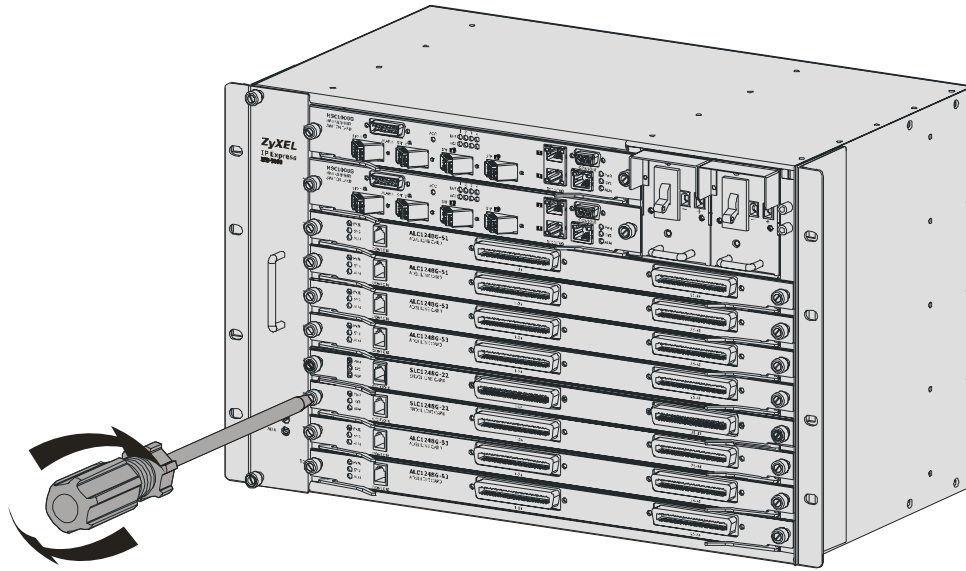


Figure 8 Closing the Ejector Levers



**Figure 9** Tightening Card Thumbscrews



### 2.3.2 Removing MSC and Line Cards

- 1 Disconnect all cables from the card.
- 2 Loosen the two thumbscrews.
- 3 Pull the two ejector levers firmly until the front of the card is clear of the chassis. Pull the ejector levers until they are perpendicular to the front panel.
- 4 Grasp the center of the front panel of the card with one hand and place the other hand under the card to support it.
- 5 Slide the card out of the slot.

**Figure 10** Loosening Card Thumbscrews

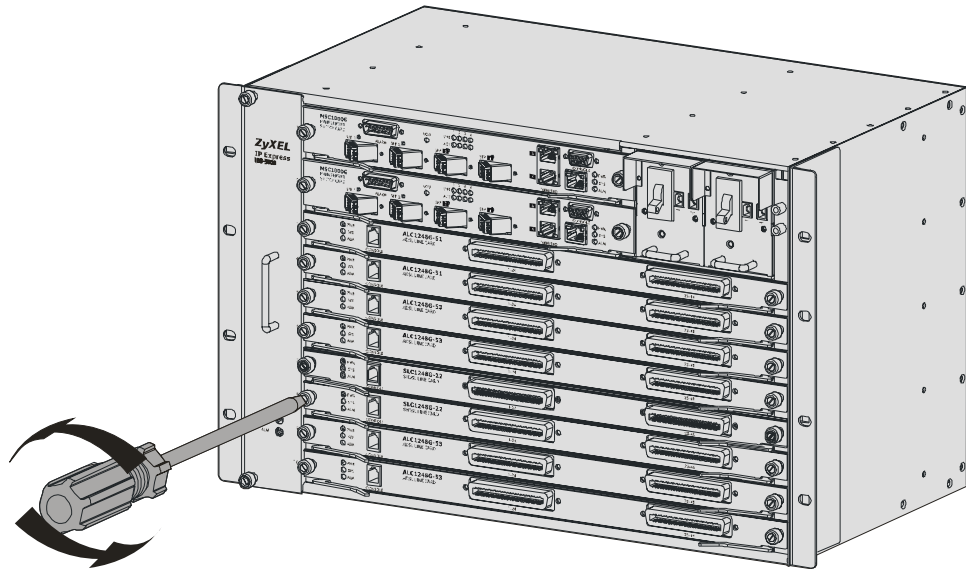


Figure 11 Opening the Ejector Levers

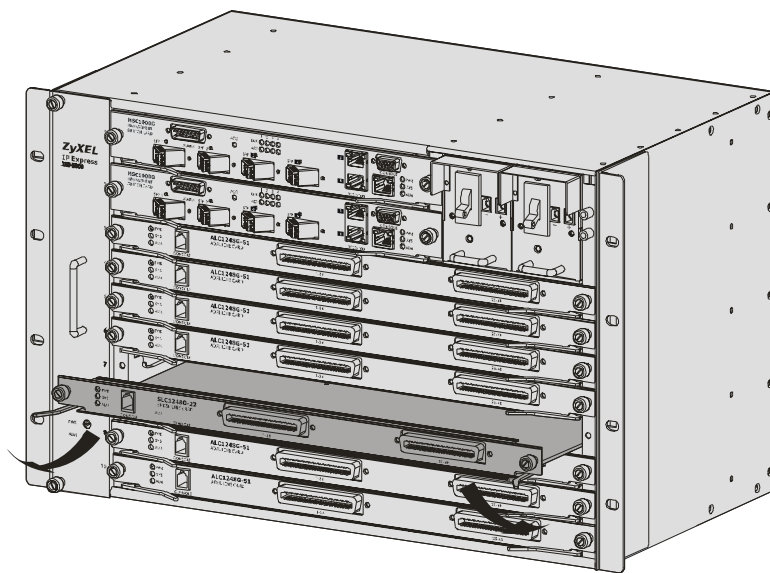
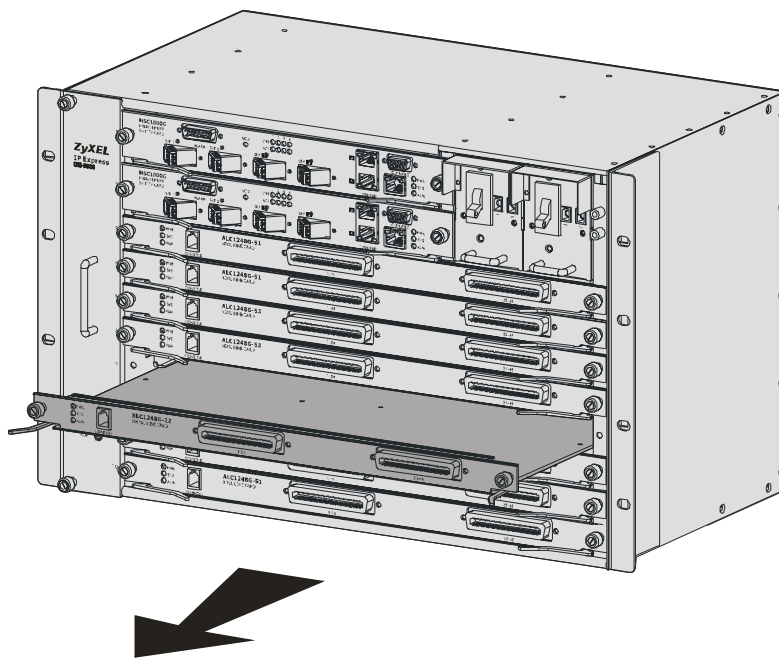


Figure 12 Removing a Main Chassis Card



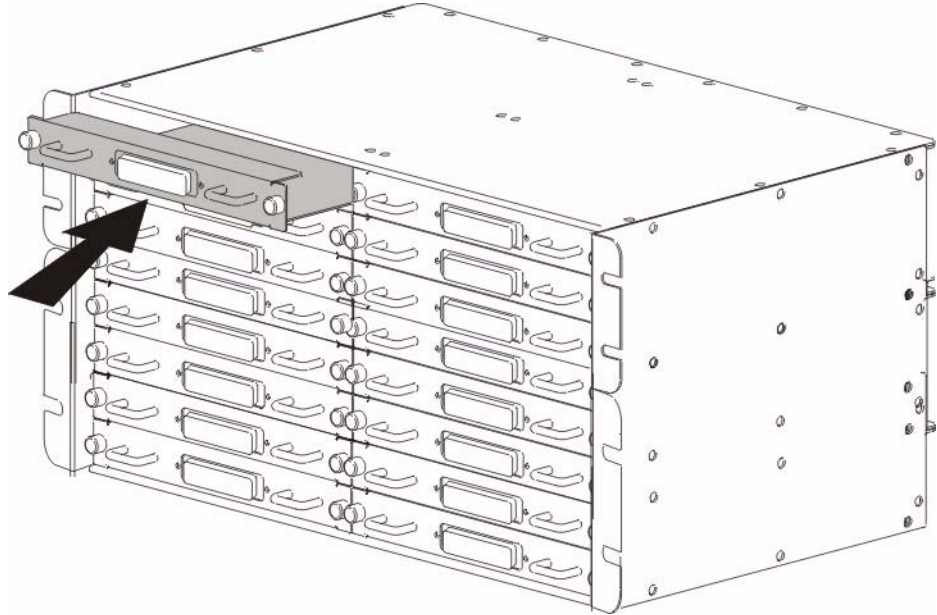
### 2.3.3 Installing a Splitter Chassis Card

The splitter card's type and slot number must match those of the line card to which it is to connect. For example, install ASC1024 cards in slots 3-1 and 3-2 of the splitter chassis if there is an ALC1248G line card in slot 3 of the main chassis. Use the SEC1024 extension card with the VOP1248G VoIP line card. Leave the slot covers on unused splitter slots.

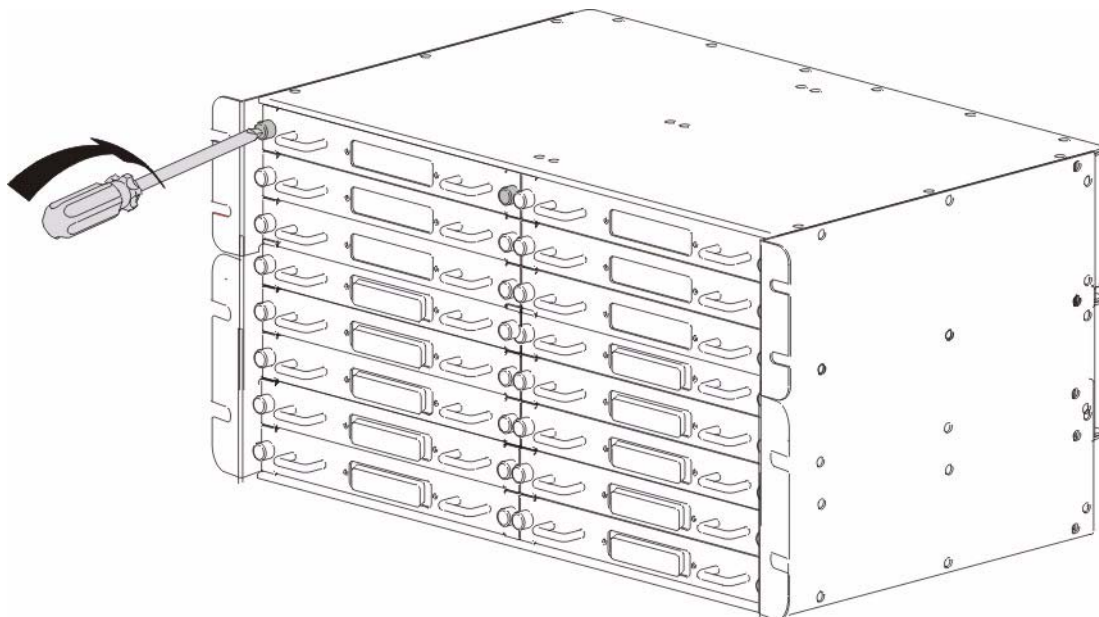
Use the following procedure to install a splitter card in the splitter chassis.

- 1 Install the splitter cards in the splitter chassis slots that correspond to the slot number of the line card in the main chassis (a management switch card does not need a splitter chassis card).
- 2 Grasp the center of the front panel of the card with one hand and place the other hand under the card to support it.
- 3 Insert the card into the slot and push it in until the front panel of the card is flush with the front panel of the splitter chassis.
- 4 Tighten the two thumbscrews.

**Figure 13** Installing a Splitter Chassis Card



**Figure 14** Tightening Splitter Chassis Card Thumbscrews

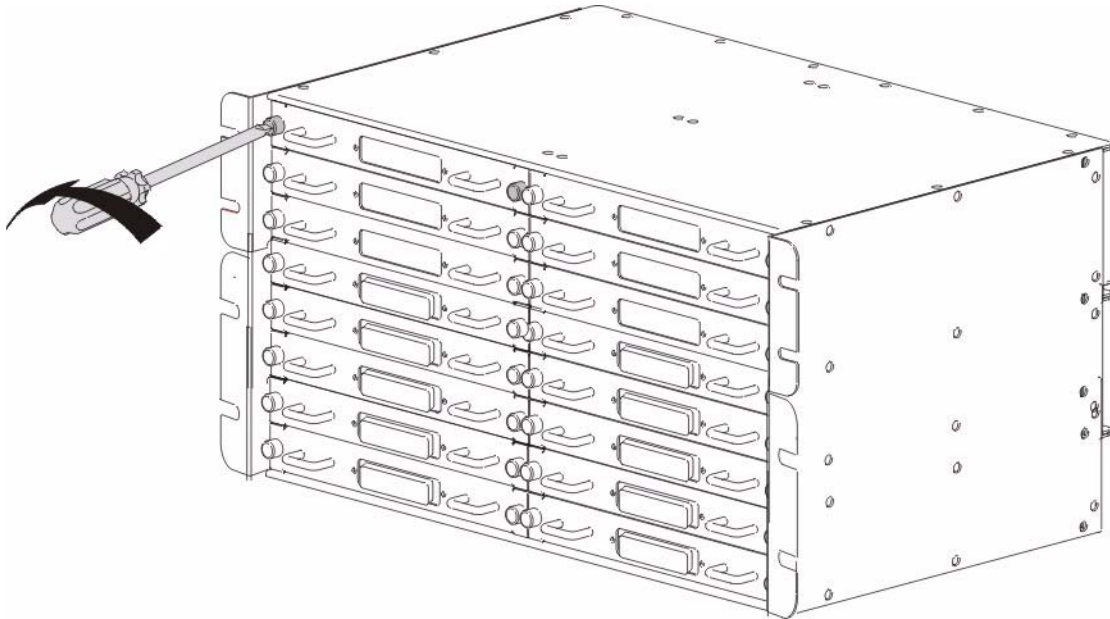


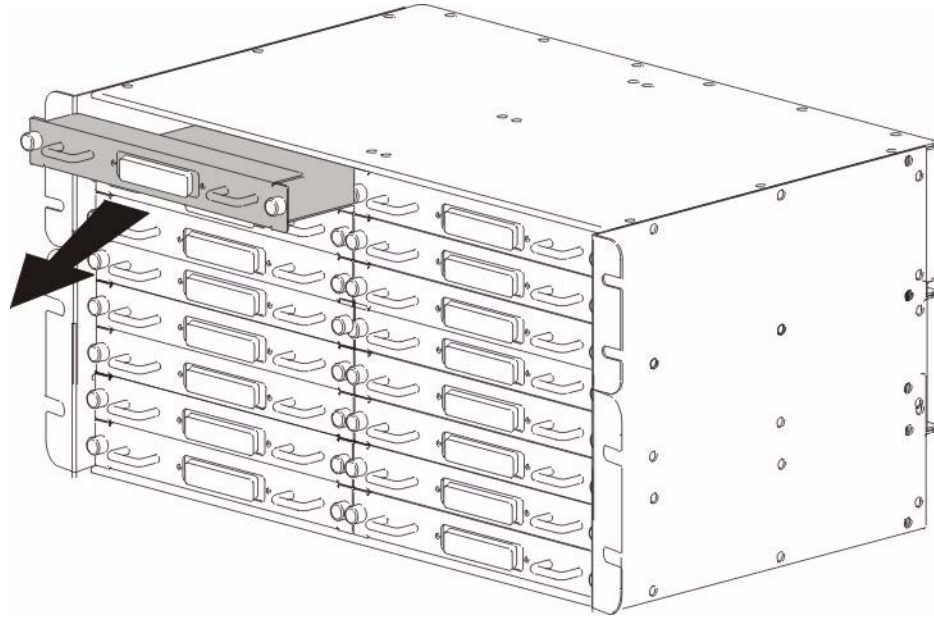
### 2.3.4 Removing a Splitter Chassis Card

Use the following procedure to remove a splitter card from the splitter chassis.

- 1 Disconnect the cable from the card.
- 2 Loosen the two thumbscrews.
- 3 Grasp the handles on the front panel of the card and start to pull the card out.
- 4 After you have the card partially out of the chassis, place one hand under the card to support it.
- 5 Slide the card out of the slot.

**Figure 15** Loosening Splitter Chassis Card Thumbscrews



**Figure 16** Removing a Splitter Chassis Card

## 2.4 Making Card Connections

The following describes how to connect the line cards to the splitter chassis cards. For the management switch card, refer to the card's User's Guide for instructions on making the connections.

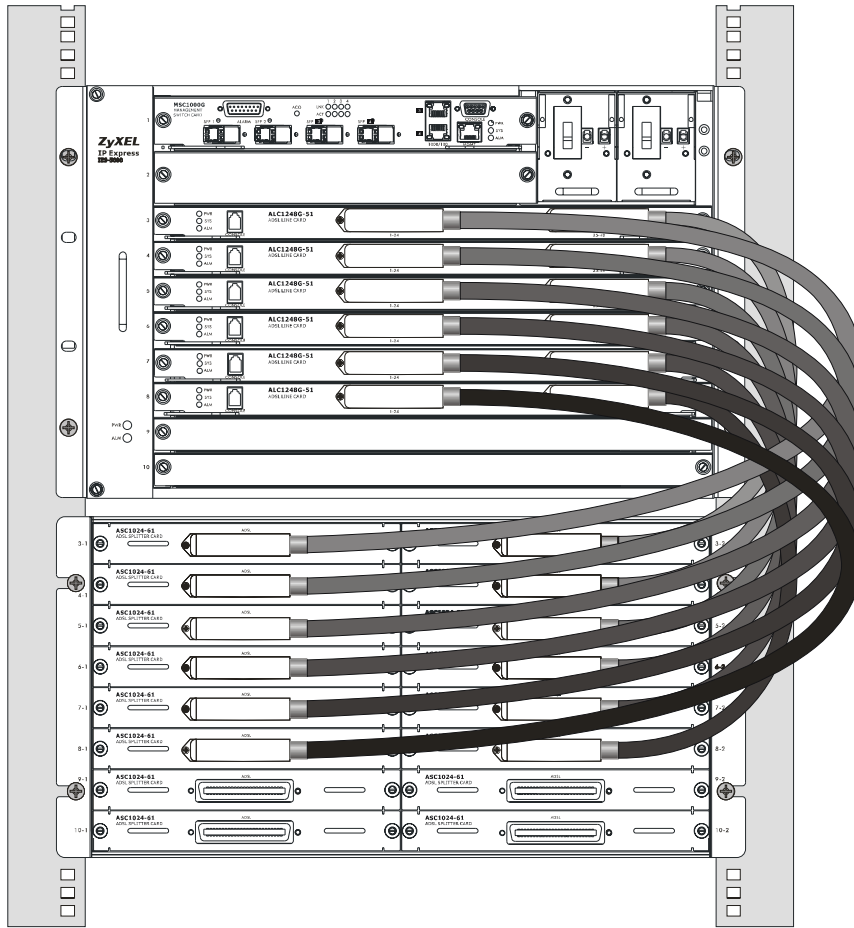
### 2.4.1 48-port Line Card Connections

Use a Telco-50 cable to connect the line card's front panel Telco-50 connector to the corresponding splitter card's front panel Telco-50 connector. Make sure that you use the appropriate length Telco-50 cables with the line cards; using cables of the wrong length blocks access to other cards. See the specifications appendix for the lengths of ZyXEL's optional Telco-50 cables.

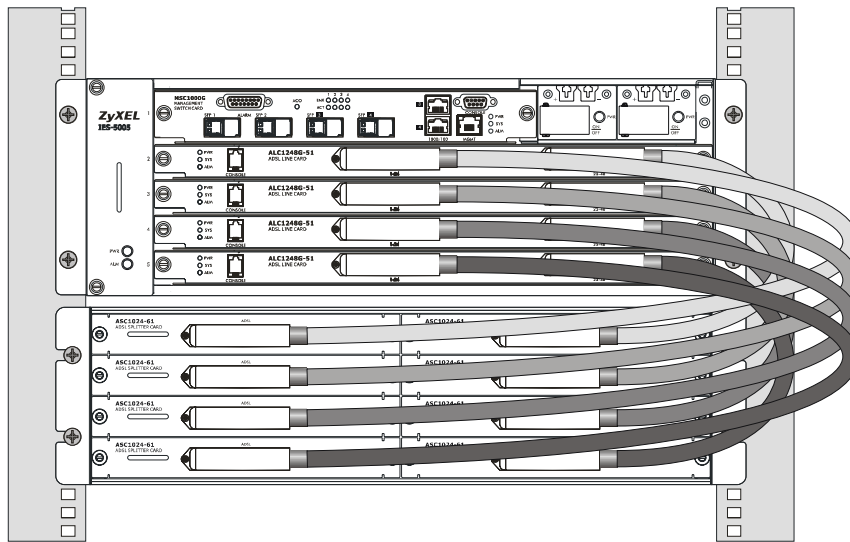
Use a long Telco-50 cable to connect a line card's **1-24** Telco-50 connector to the Telco-50 connector on the corresponding splitter card in the left column (labeled x-1) of the splitter chassis.

Use a short Telco-50 cable to connect a line card's **25-48** Telco-50 connector to the Telco-50 connector on the corresponding splitter card in the right column (labeled x-2) of the splitter chassis.

**Figure 17** IES-5000 Front Panel Telco-50 Connections (with 6 Line Cards)

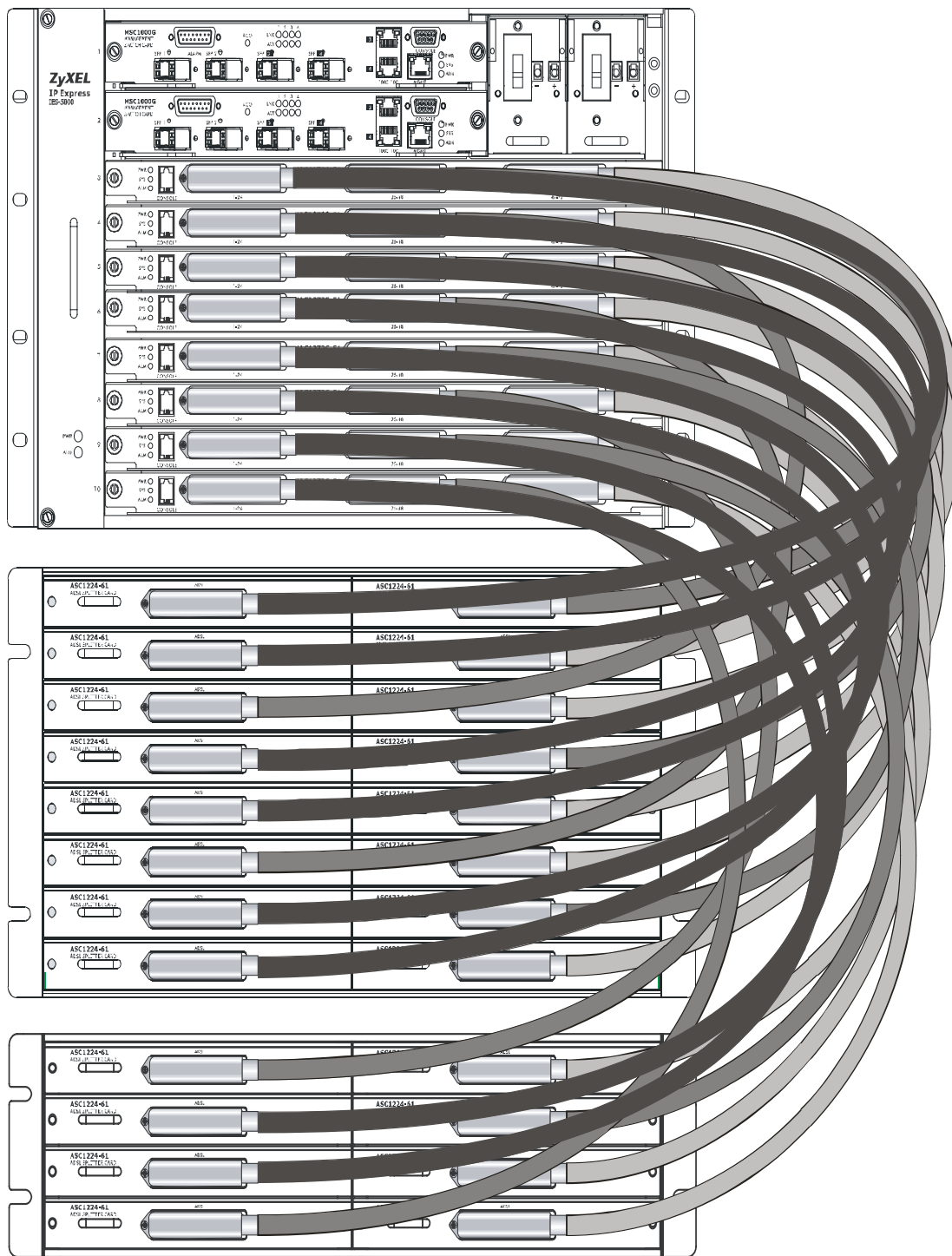


**Figure 18** IES-5005 Front Panel Telco-50 Connections (with 4 Line Cards)



## 2.4.2 IES-5000 72-port Line Card Connections

When using 72-port line cards (such as the ALC1272G) in the IES-5000, use an IES-5000ST splitter card chassis in conjunction with an IES-5005ST splitter card chassis, as shown in the following figure.

**Figure 19** IES-5000 Front Panel Telco-50 Connections (with 72-port Line Cards)

The 72-port line cards use long, medium and short Telco-50 cables (see [Appendix A on page 75](#) for the exact lengths of each cable).



These cables are different in length from the “long” and “short” cables used with the other line cards. See the appendix on product specifications for details.

- Use a long Telco-50 cable to connect a 72-port line card’s **1~24** Telco-50 connector to the Telco-50 connector on the corresponding splitter card.
- Use a medium Telco-50 cable to connect a 72-port line card’s **25~48** Telco-50 connector to the Telco-50 connector on the corresponding splitter card.
- Use a short Telco-50 cable to connect a 72-port line card’s **49~72** Telco-50 connector to the Telco-50 connector on the corresponding splitter card.
- Connect the **49~72** Telco-50 connectors first, the **25~48** Telco-50 connectors second, and the **1~24** Telco-50 connectors last.

#### 2.4.2.1 IES-5000 72-port Line Card to Splitter Card Connections

Connect the line card ports to the splitter card ports as described in the following table, which represents the IES’s front panel. In the numbers in this table, the first number refers to the line card’s slot in the IES-5000 (**1 to 8**) and the numbers in parentheses refer to the Telco-50 port connector on the line card (ports **1~24**, **25~48** and **49~72**).

**Table 1** 72-port Line Card Connections

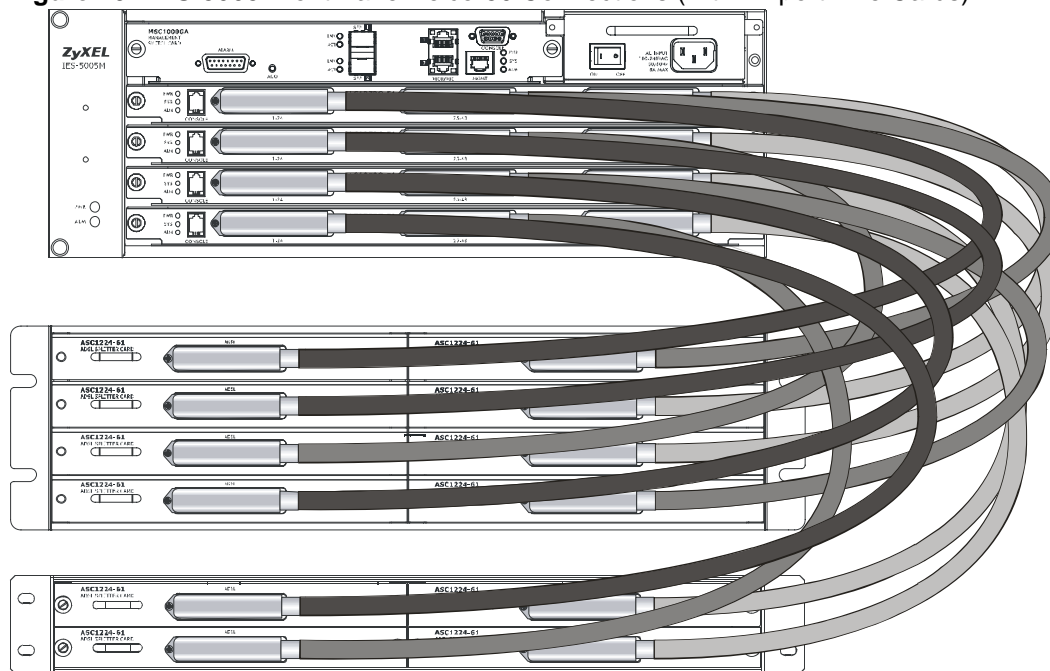
CHASSIS	SLOT #	LINE CARD TELCO-50 CONNECTORS		
IES-5000	1	<b>1 (1~24)</b>	<b>1 (25~48)</b>	<b>1 (49~72)</b>
	2	2 (1~24)	2 (25~48)	2 (49~72)
	3	<b>3 (1~24)</b>	<b>3 (25~48)</b>	<b>3 (49~72)</b>
	4	4 (1~24)	4 (25~48)	4 (49~72)
	5	<b>5 (1~24)</b>	<b>5 (25~48)</b>	<b>5 (49~72)</b>
	6	6 (1~24)	6 (25~48)	6 (49~72)
	7	<b>7 (1~24)</b>	<b>7 (25~48)</b>	<b>7 (49~72)</b>
	8	8 (1~24)	8 (25~48)	8 (49~72)
		SPLITTER CARD TELCO-50 CONNECTORS		
IES-5000ST	1	<b>1 (1~24)</b>	<b>1 (25~48)</b>	
	2	2 (1~24)	<b>1 (49~72)</b>	
	3	2 (25~48)	2 (49~72)	
	4	<b>3 (1~24)</b>	<b>3 (25~48)</b>	
	5	4 (1~24)	<b>3 (49~72)</b>	
	6	4 (25~48)	4 (49~72)	
	7	<b>5 (1~24)</b>	<b>5 (25~48)</b>	
	8	6 (1~24)	<b>5 (49~72)</b>	

**Table 1** 72-port Line Card Connections

IES-5005ST	1	6 (25~48)	6 (49~72)
	2	7 (1~24)	7 (25~48)
	3	8 (1~24)	7 (49~72)
	4	8 (25~48)	8 (49~72)

### 2.4.3 IES-5005 72-port Line Card Connections

When using 72-port line cards (such as the ALC1272G) in the IES-5005, use an IES-5005ST splitter card chassis in conjunction with an IES-5002ST splitter card chassis, as shown in the following figure.

**Figure 20** IES-5005 Front Panel Telco-50 Connections (with 72-port Line Cards)

The 72-port line cards use long, medium and short Telco-50 cables (see [Appendix A on page 75](#) for the exact lengths of each cable).



These cables are different in length from the “long” and “short” cables used with the other line cards. See the appendix on product specifications for details.

- Use a long Telco-50 cable to connect a 72-port line card’s **1~24** Telco-50 connector to the Telco-50 connector on the corresponding splitter card.
- Use a medium Telco-50 cable to connect a 72-port line card’s **25~48** Telco-50 connector to the Telco-50 connector on the corresponding splitter card.

- Use a short Telco-50 cable to connect a 72-port line card's **49~72** Telco-50 connector to the Telco-50 connector on the corresponding splitter card.
- Connect the **49~72** Telco-50 connectors first, the **25~48** Telco-50 connectors second, and the **1~24** Telco-50 connectors last.

### 2.4.3.1 IES-5005 72-port Line Card to Splitter Card Connections

The 72-port line cards use long, medium and short Telco-50 cables (see [Appendix A on page 75](#) for the exact lengths of each cable).



These cables are different in length from the “long” and “short” cables used with the other line cards. See the appendix on product specifications for details.

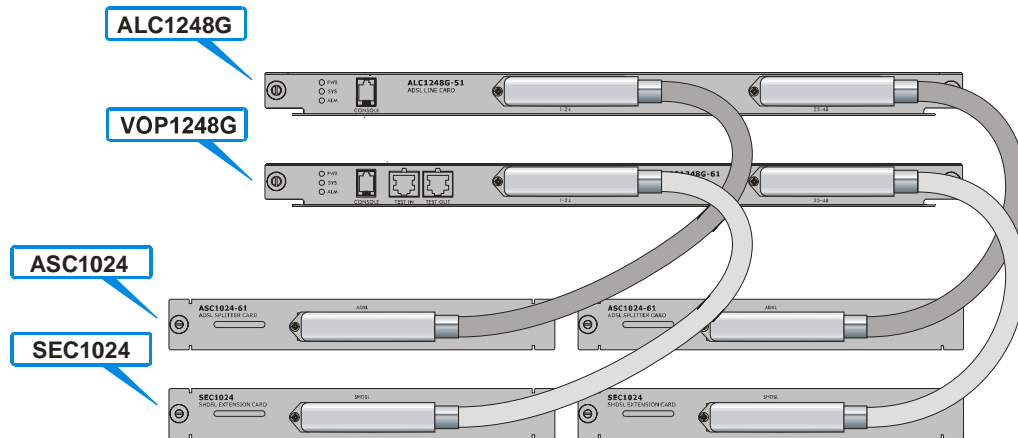
Connect the line card ports to the splitter card ports as described in the following table, which represents the IES's front panel. In the numbers in this table, the first number refers to the line card's slot in the IES-5000 (**1 to 4**), the numbers in parentheses refer to the Telco-50 port connector on the line card (ports **1~24**, **25~48** and **49~72**), and the letter refers to the length of Telco-50 cable (**S** for short, **M** for medium, and **L** for long).

**Table 2** IES-5005M 72-port Line Card Connections

CHASSIS	SLOT #	LINE CARD TELCO-50 CONNECTORS		
IES-5005	1	<b>1 (1~24)</b>	<b>1 (25~48)</b>	<b>1 (49~72)</b>
	2	2 (1~24)	2 (25~48)	2 (49~72)
	3	<b>3 (1~24)</b>	<b>3 (25~48)</b>	<b>3 (49~72)</b>
	4	4 (1~24)	4 (25~48)	4 (49~72)
		SPLITTER CARD TELCO-50 CONNECTORS		
IES-5005ST	1	<b>1 (1~24)</b>	<b>1 (25~48)</b>	
	2	2 (1~24)	<b>1 (49~72)</b>	
	3	2 (25~48)	2 (49~72)	
	4	<b>3 (1~24)</b>	<b>3 (25~48)</b>	
IES-5002ST	1	4 (1~24)	<b>3 (49~72)</b>	
	2	4 (25~48)	4 (49~72)	

### 2.4.4 VoIP Line Card Telco-50 Connections

When you use a VoIP line card in conjunction with an ADSL or VDSL card, place the VoIP card and its extension cards in the chassis directly adjacent to the DSL card and its splitter cards, as shown in the following figure (this example uses the ALC line card and ASC1024 splitter).

**Figure 21** DSL and VoIP Front Panel Telco-50 Connections (2 Splitter Chassis)

Use a Telco-50 cable to connect the SEC1024's **USER** Telco-50 connector on the rear of the splitter chassis to the **CO** Telco-50 connector on the rear of an ADSL or VDSL splitter card.

Alternatively, use a Telco-50 cable to connect the SEC1024's **USER** Telco-50 connector directly to the Main Distribution Frame when no ADSL/VDSL service is required (see [Section 2.4.6 on page 43](#)).

### 2.4.5 Splitter Chassis Rear Panel Connections (DSL)

A DSL splitter card separates the voice signal from the DSL signal. It feeds the DSL signals to the DSL line card and diverts the voice signal to the **CO** Telco-50 connector (or wire wrapping pins) on the splitter chassis' rear.

Connect the **CO** Telco-50 connectors to the PBX or PSTN/ISDN switch when using the ADSL splitter card.

Connect the **USER** Telco-50 connectors to the subscribers' telephone wiring. In most multi-tenant unit applications, the **USER** pins connect to the subscribers' telephone wiring via Main Distribution Frame (MDF).

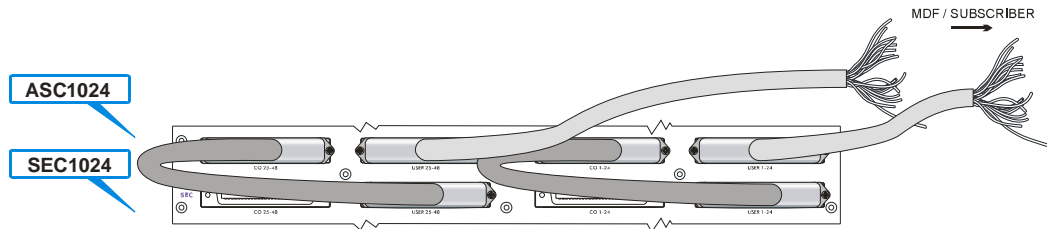
See [Section 2.5.4 on page 46](#) for example splitter chassis rear panel connections.

### 2.4.6 Splitter Chassis Rear Panel Connections (VoIP)

When using the VoIP line card in conjunction with an ADSL or VDSL card and its associated splitter card(s), connect the VoIP line card's extension card(s) and the DSL splitter card(s) as follows.



Use 180-degree Telco-50 cables for VoIP rear panel connections (see [Appendix A on page 75](#) for information on 180-degree Telco-50 cable length).

**Figure 22** DSL and VoIP Rear Panel Telco-50 Connections (2 Splitter Chassis)

- Connect the **USER** Telco-50 connector from the extension card attached to the VoIP line card's **1 ~ 24** ports to the **CO** Telco-50 connector of the splitter card attached to the DSL line card's **1 ~ 24** ports.
- Connect the **USER** Telco-50 connector from the extension card attached to the VoIP line card's **25 ~ 48** ports to the **CO** Telco-50 connector of the splitter card attached to the DSL line card's **25 ~ 48** ports.

When you do not use the VoIP line card in conjunction with a DSL splitter card, connect the USER Telco-50 connectors to the subscribers' telephone wiring. In most multi-tenant unit applications, the **USER** pins connect to the subscribers' telephone wiring via a Main Distribution Frame (MDF).

## 2.5 MDF Connections

This section shows you how to connect the IES-5000 splitter chassis to a Main Distribution Frame.

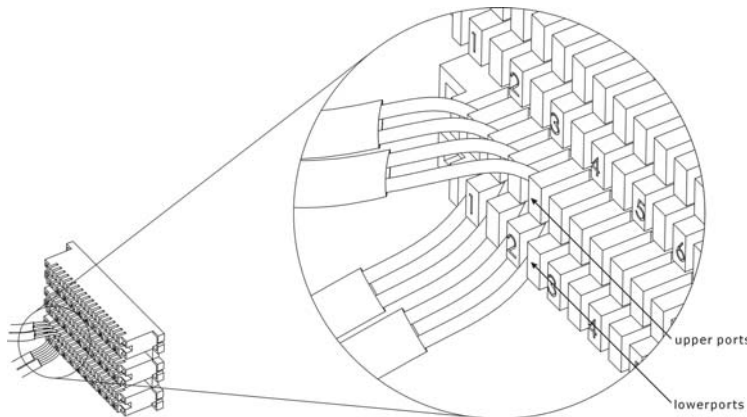
### 2.5.1 MDF Connections Overview

Observe the following before you start:

- Refer to [Appendix A on page 75](#) for the gauge of telephone wire to use.
- Follow the pin assignments shown in the line card User's Guide to wire Telco-50 cables to Telco-50 connectors.

### 2.5.2 MDF (Main Distribution Frame)

An MDF is usually installed between subscribers' equipment and the telephone company (CO) in a basement or telephone room. The MDF is the point of termination for the outside telephone company lines coming into a building and the telephone wiring in the building.

**Figure 23** MDF (Main Distribution Frame) Wiring

- Connect wiring to end-user equipment to the lower ports of an MDF and connect wiring from the telephone company to the upper ports of an MDF (see the previous figure).
- Some MDFs have surge protection circuitry built in between the two banks; thus, do not connect telephone wires from the telephone company directly to your IES-5000.
- Use a punch-down tool to seat telephone lines into MDF blocks.

### 2.5.3 Telco-50 Cables

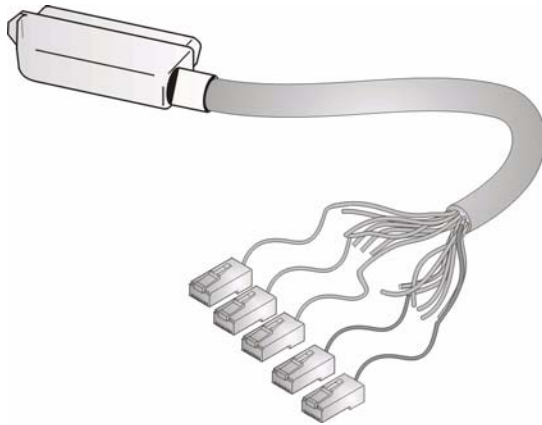
Telco-50 cables are used for data and voice applications with MDFs (Main Distribution Frame), patch panels and distribution boxes. They can also be used as extension cables. Telco-50 cables are made up of 25 twisted-pair copper wires.

Connect a Telco-50 connector to one end of the cable (see the User's Guide for the individual line card for pin assignments) and connect the other end directly to an MDF; alternatively attach RJ-11 connectors and connect directly to DSL modems or telephones.



The cable shown below uses a 90-degree Telco-50 connector, where the cable extends from the side of the connector (at ninety degrees to the port). For rear-panel splitter chassis connections using the VOP-1248G VoIP line card, use a 180-degree Telco-50 connector (where the cable extends from the base of the connector directly opposite the port).

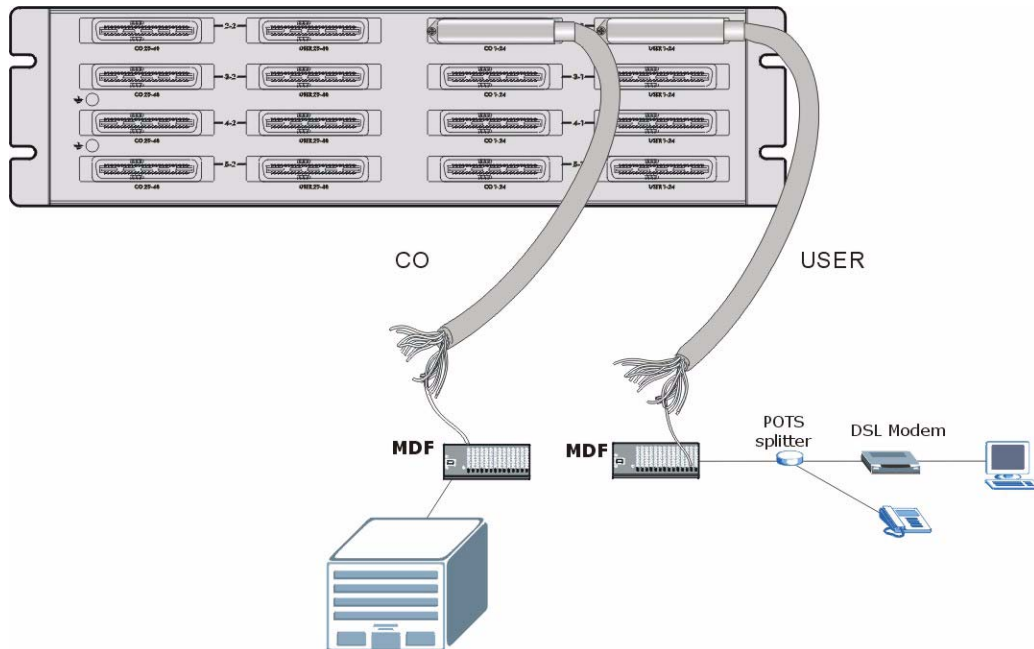
**Figure 24** Telco-50 Cable with RJ-11 Connectors



## 2.5.4 MDF Connections

The following section gives an overview of possible installation scenarios for the IES-5000 using the line cards and splitter cards. Data and voice signals can coexist on the same telephone wiring.

**Figure 25** Installation Overview Example



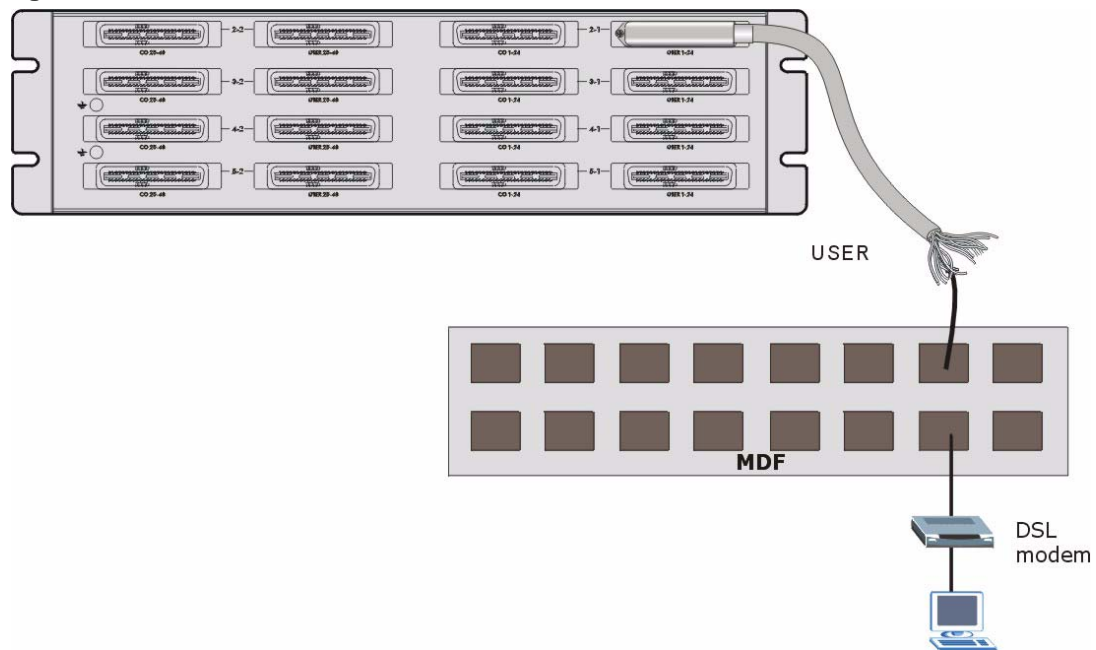
You can also attach RJ-11 connectors to the Telco-50 cable and connect directly to a DSL modem(s), a telephone(s) or a patch panel. This chapter discusses connections using MDFs. The following sections describe typical installation scenarios.

### 2.5.4.1 MDF Installation Scenario A

You want to install the IES-5000 in an environment where there are no previously installed MDFs. There is no phone service and you want to install the IES-5000 for data-access only. No connection from the Telco-50 CO connector is necessary. G.SHDSL connections carry data only, thus they are best suited to this installation scenario.

You can connect using an MDF or attach RJ-11 connectors to the non-IES-5000 end of the Telco-50 cable and then connect to DSL modems or telephones directly.

**Figure 26** Installation Scenario A



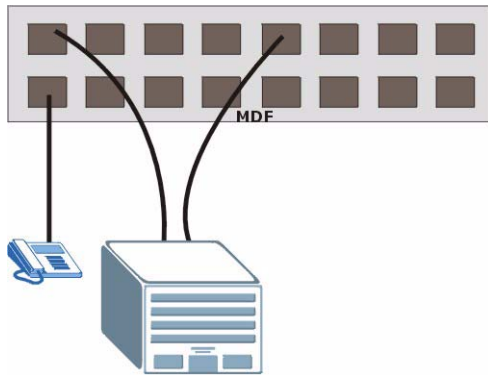
Use the following procedure for this MDF installation scenario.

- 1 Connect the Telco-50 connector end of the cable to the Telco-50 connector labeled **USER**.
- 2 Connect the wiring on the other end of the Telco-50 cable to the upper ports of the MDF using a punch-down tool.
- 3 Connect the telephone wiring from each end-user's DSL modem to the lower ports of the MDF.

### 2.5.4.2 Installation Scenario B

Phone service is available. There is one MDF from which end-users CO connections are made (see next figure). This installation scenario does not apply to G.SHDSL connections.

**Figure 27** One MDF for End-user and CO Connections



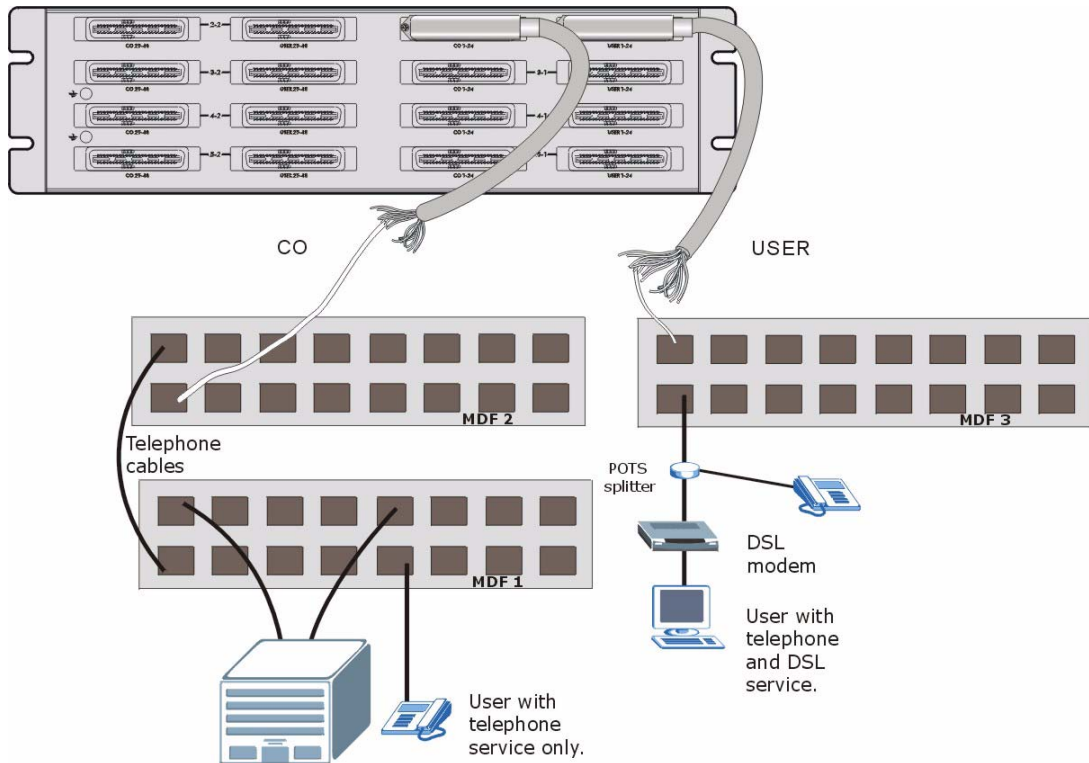
This installation scenario requires three MDFs. Please refer to the following figure for the connection schema.

- MDF 1 is the original MDF used for telephone connections only.
- MDF 2 is used for telephone connections only.
- MDF 3 is for DSL service connections.



Change the wiring from MDF 1 to MDF 3 for telephone subscribers who want DSL service.

**Figure 28** Installation Scenario B



Use the following procedure for this MDF installation scenario.

- 1 Connect the Telco-50 connector end of the cable you want for DSL service to the Telco-50 connector labeled **USER** on the splitter chassis rear panel.
- 2 Connect the wiring on the other side of the Telco-50 cable to the upper ports of MDF 3 using a punch-down tool.
- 3 Connect the telephone wiring from the end-user's DSL modem(s) to the lower ports of MDF 3.
- 4 Connect the Telco-50 connector end of the cable you want for phone service to the Telco-50 connector labeled **CO** on the splitter chassis rear panel.
- 5 Connect the wiring on the other side of the Telco-50 cable to the lower ports of MDF 2 using a punch-down tool.
- 6 Connect the upper ports of MDF 2 to the lower ports of MDF 1 using telephone wires.
- 7 Connect the upper ports of MDF 1 to the telephone company.
- 8 Telephone subscribers only (non-DSL subscribers) retain connections to the lower ports of MDF 1.
- 9 Change the wiring from MDF 1 to MDF 3 for telephone subscribers who want DSL service.

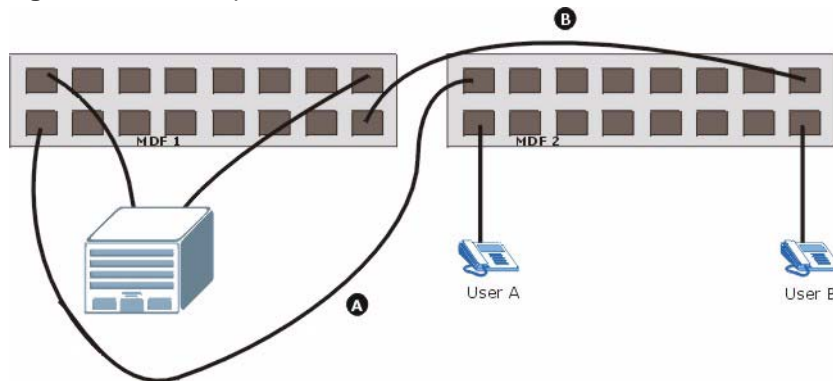
#### 2.5.4.3 Installation Scenario C

Phone service is also available but there are two MDFs; one for end-user telephone line connections and the other one for CO telephone wiring connections (see the following figure). This installation scenario does not apply to G.SHDSL connections.



Users A and B have telephone service only.

**Figure 29** Two Separate MDFs for End-user and CO Connections



This installation scenario requires four MDFs. Please refer to the following figure for the DSL connection schema.

- MDFs 1 and 2 are the two original MDFs.
- MDFs 3 and 4 are two additional MDFs you need.



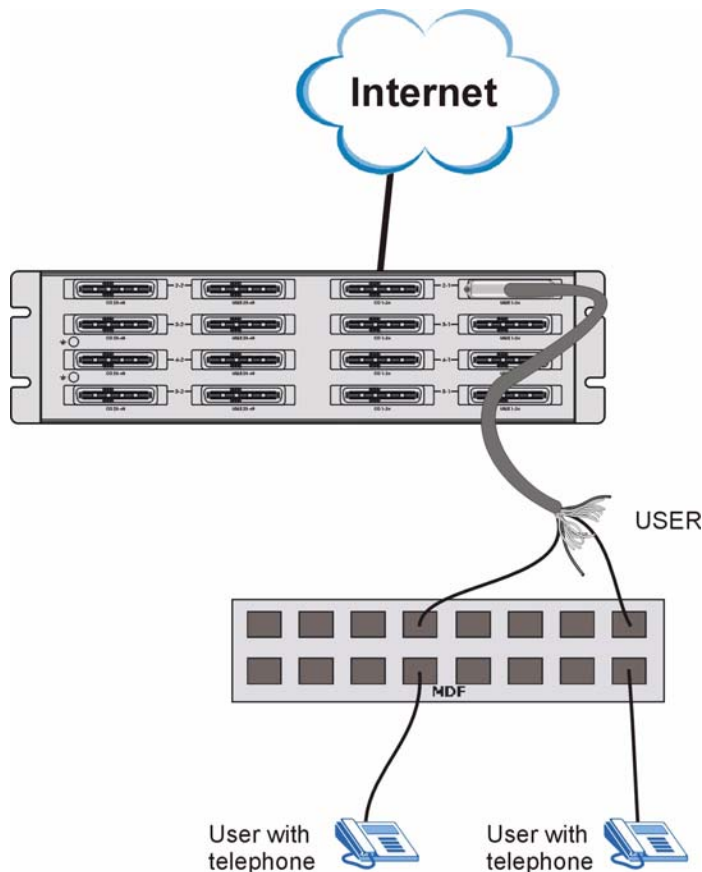
## 2.5.5 VoIP Connection Scenarios

These scenarios describe how to use the VOP1248G VoIP line card to provide voice service to your subscribers.

### 2.5.5.1 VoIP Installation Scenario A

In this installation scenario, you use a VoIP line card, an SEC1024 extension card and an MDF to provide voice service over the Internet to your subscribers.

**Figure 31** VoIP Connection Scenario A



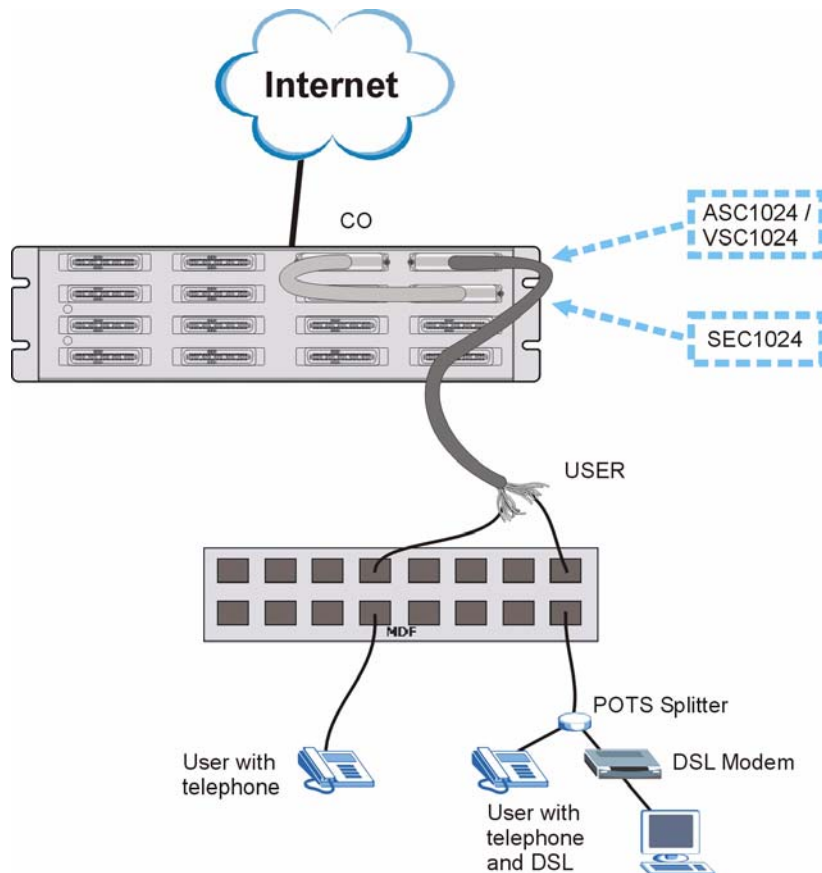
Use the following procedure for this installation scenario.

- 1 Connect the Telco-50 connector end of the cable you want to use for voice service to the Telco-50 connector labeled **USER** on the splitter chassis rear panel.
- 2 Connect the wiring on the other side of the Telco-50 cable to the upper ports of the MDF using a punch-down tool.
- 3 Connect the telephone wiring from the end-user's POTS telephone equipment to the lower ports of the MDF.

### 2.5.5.2 VoIP Installation Scenario B

In this installation scenario, you use a VoIP line card and an SEC1024 extension card in conjunction with a DSL line card, its associated splitter card and an MDF to provide voice service over the Internet and DSL Internet access to certain subscribers (a DSL line card port is reserved for each user even if the user does not subscribe to DSL). See [Section 2.4.4 on page 42](#) and [Section 2.4.6 on page 43](#) for more information on using the VOP1248G in conjunction with DSL line cards. This installation scenario does not apply to G.SHDSL connections.

**Figure 32** VoIP Connection Scenario B



Use the following procedure for this installation scenario.

- 1 Connect the Telco-50 connector end of the cable you want to use for voice and data service to the Telco-50 connector labeled **USER** on the DSL splitter card's rear panel.
- 2 Connect the wiring on the other end of the Telco-50 cable to the upper ports of the MDF using a punch-down tool.
- 3 Connect the telephone wiring from the end-user's DSL and POTS equipment to the lower ports of the MDF.
- 4 Using another Telco-50 cable, connect the **CO** port on the DSL splitter card to the **USER** port on the SEC1024 extension card.
- 5 Connect the Telco-50 port on the front of the DSL splitter card to the **1 ~ 24** port on the front of the DSL line card.
- 6 Connect the Telco-50 port on the front of the SEC extension card to the **1 ~ 24** port on the front of the VoIP line card.

## 2.6 Power Connections

This section shows you how to connect the IES-5000 to a power source.

Use the following procedures to connect the IES-5000 to a power source after you have installed the chassis in a rack.



---

Refer to [Appendix A on page 75](#) for power requirements and make sure you are using an appropriate power source.

---

Observe the following before you start:

- Keep the IES-5000 power switches in the **OFF** position until you come to procedure for turning on the power.
- Keep the power supply switch in the **OFF** position until you come to procedure for turning on the power.



---

Use only power wires of the required diameter for connecting the IES-5000 to a power supply (refer to [Appendix A on page 75](#) for the required wire gauge).

---

### 2.6.1 Power Modules

The main chassis uses two power supply modules. These modules are hot-swappable and supply power to the chassis cards.

The power connections are at the upper-right corner of the front panel of the chassis. See [Section 2.6.2 on page 56](#) for how to connect the power to the IES-5000M, and see [Section 2.6.3 on page 59](#) for how to connect the power to the IES-5005M.



---

When you install or remove a power module, ensure that its power switch is turned OFF. If the module's power source also has a switch, ensure it is also turned OFF.

---

#### 2.6.1.1 Power Modules and 72-port Line Cards

The IES-5000M and IES-5005M each have an original power module type and a newer type. The newer type module can support more 72-port line cards than the original type. The following sections describe the power modules and how to identify the original and newer types. If you are still unsure which type you have, wish to obtain new power modules or upgrade fuses (IES-5005M only) contact your vendor.

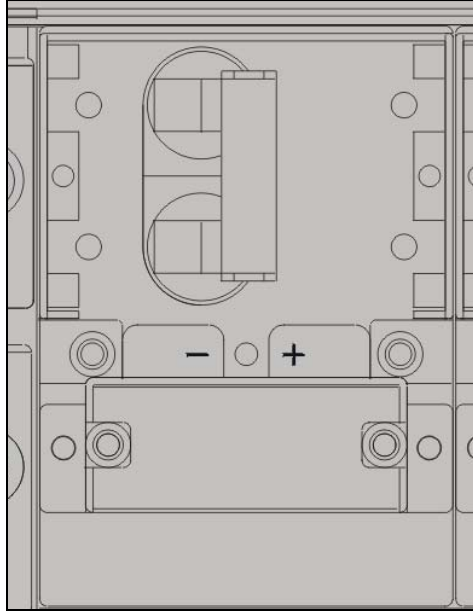


This User's Guide shows information on installing the newer type of power module.

#### 2.6.1.1.1 IES-5000M Power Module Types

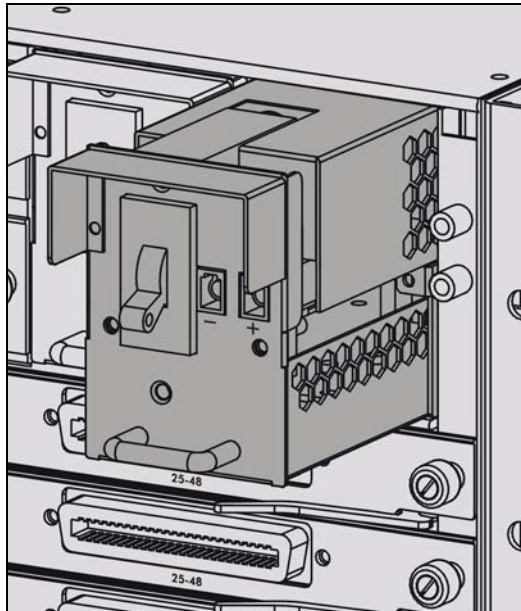
The following figure shows the original type IES-5000M power module.

**Figure 33** Original Power Module (IES-5000M)



The following figure shows the newer type IES-5000M power module.

**Figure 34** Newer Power Module (IES-5000M)



The following table describes the two types of power module.

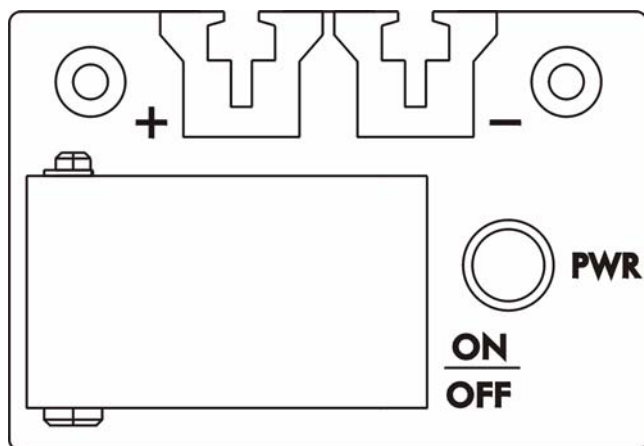
**Table 3** Power Module Differences (IES-5000M)

FEATURE	ORIGINAL TYPE	NEWER TYPE
Circuit breaker rating	20A	30A
Number of supported 72-port line cards.	6	8
Identifying features	<ul style="list-style-type: none"> <li>Red, horizontal (left-to-right) power switch.</li> <li>Power wires connect to lower part of module's front panel.</li> </ul>	<ul style="list-style-type: none"> <li>White, vertical (up-and-down) power switch.</li> <li>Power wires connect to upper part of module's front panel.</li> </ul>

### 2.6.1.1.2 IES-5005M Power Module Types

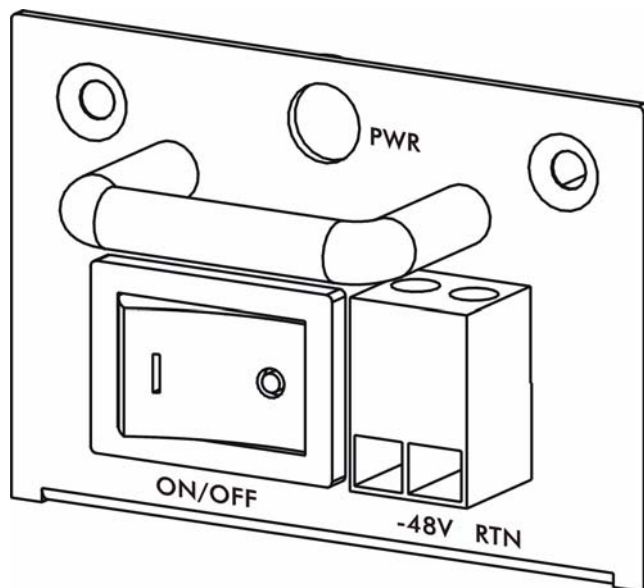
The following figure shows the original type IES-5005M power module.

**Figure 35** Original Power Module (IES-5005M)



The following figure shows the newer type IES-5005M power module.

**Figure 36** Newer Power Module (IES-5005M)



The following table describes the two types of power module.

**Table 4** Power Module Differences (IES-5005M)

FEATURE	ORIGINAL TYPE	NEWER TYPE
Supplied fuse rating	8A	15A
Number of supported 72-port line cards.	2	4
Identifying features	<ul style="list-style-type: none"> <li>Power wires clip into slots at the top of the module's front panel.</li> <li>Power block is situated inside the module.</li> </ul>	<ul style="list-style-type: none"> <li>Power wires connect to lower part of module's front panel.</li> <li>Power block is situated on module's front panel and is removable.</li> </ul>

## 2.6.2 Procedure to Connect the Power: IES-5000M

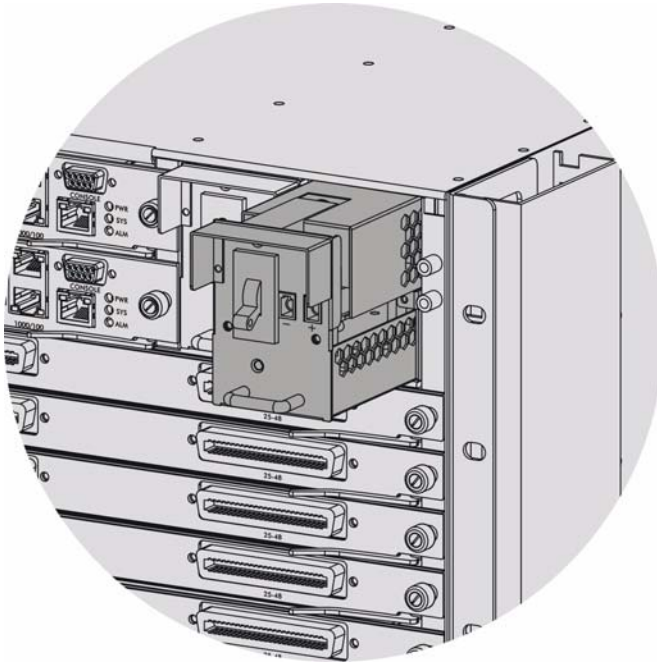


When installing the IES-5000M power wires, push the wires firmly into the terminals as deep as possible and make sure that no exposed (bare) wires can be seen or touched.

Use two wires to connect to each power module; one for the positive terminal and one for the negative terminal.

- 1 Use a screwdriver to loosen the power module screws.
- 2 Slide the power module out of the housing. Ensure that the terminal screws are sufficiently loose for the power wires to be inserted.
- 3 Connect a power wire to the negative power terminal on the front of the power module, and tighten the terminal screws.
- 4 Connect the other end of the power wire to the -48 V terminal on the power supply.
- 5 Connect a power wire to the positive power terminal on the front of the power module, and tighten the terminal screw.
- 6 Connect the other end of the power wire to the ground terminal on the power supply.
- 7 Push the power module back in and tighten the screws.
- 8 Repeat the previous steps for the second power supply module.

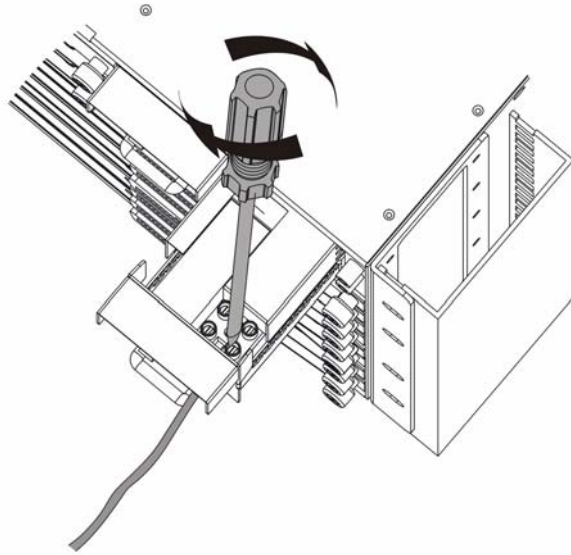
**Figure 37** Removing a Power Module (IES-5000M)



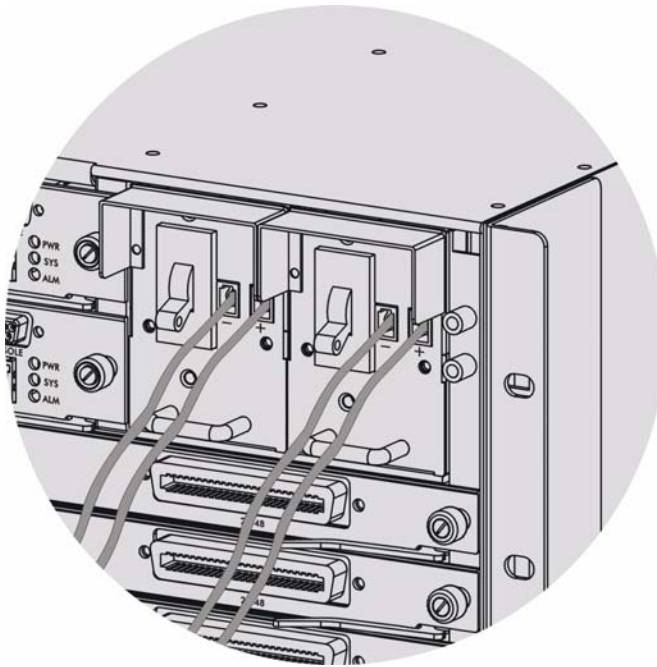
**Figure 38** Inserting Power Wires (IES-5000M)



**Figure 39** Tightening Power Module Screws (IES-5000M)



**Figure 40** Power Connected (IES-5000M)



### 2.6.2.1 Procedure to Turn on the IES-5000M Power

- 1 Turn on the power supply.
- 2 Move the power switches on both power modules to the **ON** position.

### 2.6.3 Procedure to Connect the Power: IES-5005M

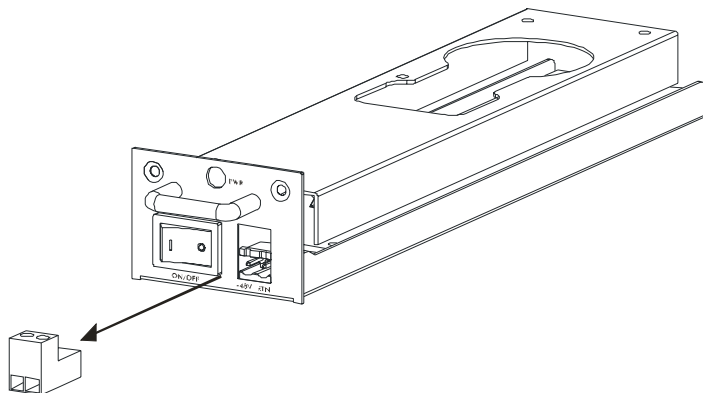


When installing the IES-5005M power wires, push the wires firmly into the terminals as deep as possible and make sure that no exposed (bare) wires can be seen or touched.

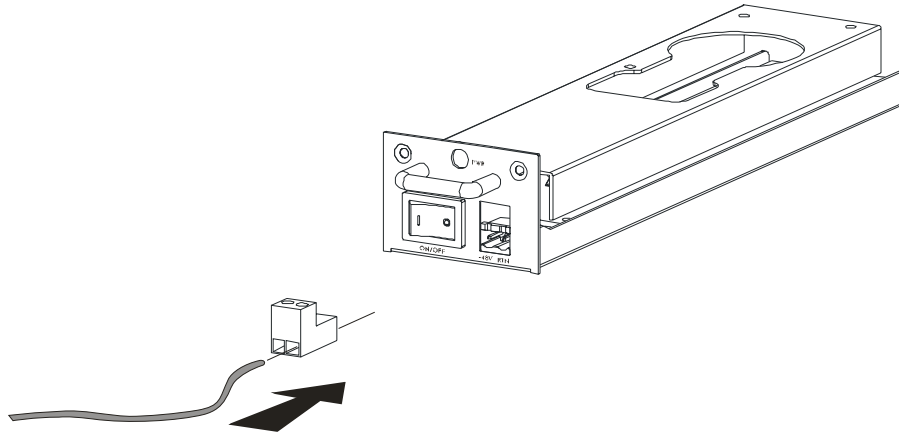
Use two wires to connect to each power module; one for the positive terminal and one for the negative terminal.

- 1 Remove the power block from the front of the power module. Ensure that the terminal screws are sufficiently loose for the power wires to be inserted.
- 2 Connect a power wire to the negative power terminal on the front of the power block, and tighten the terminal screws.
- 3 Connect the other end of the power wire to the  $-48$  V terminal on the power supply.
- 4 Connect a power wire to the positive power terminal on the front of the power block, and tighten the terminal screw.
- 5 Connect the other end of the power wire to the ground terminal on the power supply.
- 6 Push the power block back in.
- 7 Repeat the previous steps for the second power supply module.

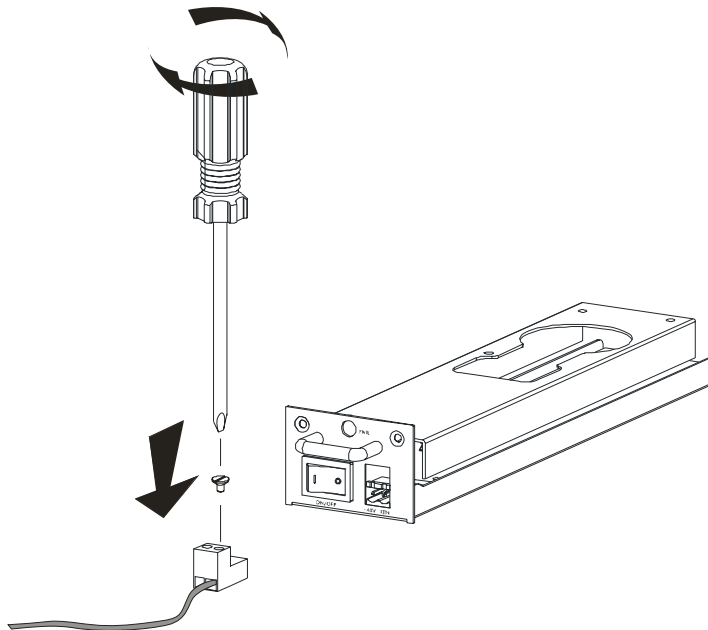
**Figure 41** Removing the Power Block (IES-5005M)



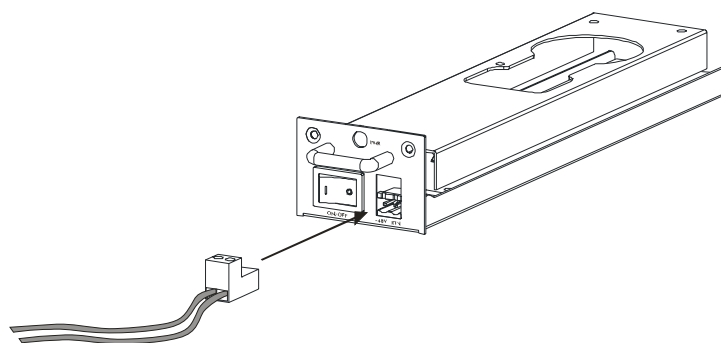
**Figure 42** Inserting Power Wires (IES-5005M)



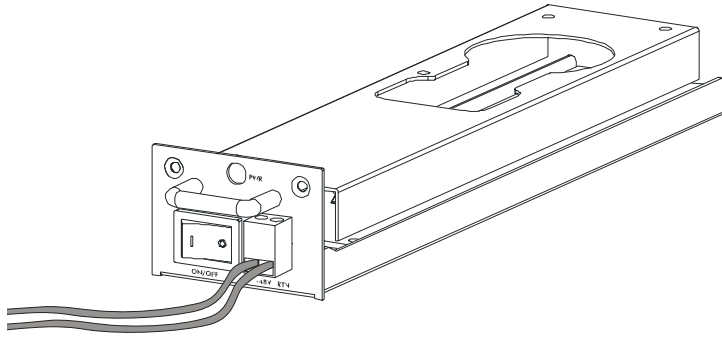
**Figure 43** Tightening Power Module Screws (IES-5005M)



**Figure 44** Replacing Power Block (IES-5005M)



**Figure 45** Power Connected (IES-5005M)



### 2.6.3.1 Procedure to Turn on the IES-5005M Power

- 1 Turn on the power supply.
- 2 Move the power switches on both power modules to the **ON** position.



---

# PART III

# Maintenance and Troubleshooting

---

Maintenance (65)

Hardware Troubleshooting (69)



# Maintenance

This chapter describes how to troubleshoot and maintain the system.

## 3.1 Fan Maintenance

This section describes how to change a fan fuse or a fan module on the IES-5000.

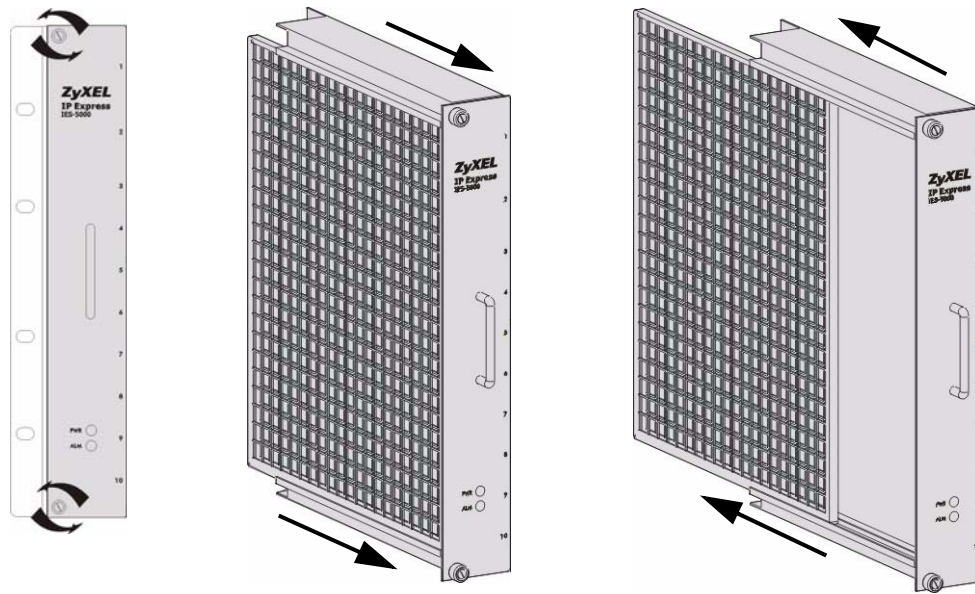
### 3.1.1 Procedure to Remove and Install the Fan Module

The main chassis has a hot-swappable fan module. The fan module is at the left on the front panel. Replace the entire fan module if the fuse is not the problem. Return any malfunctioning fan modules to the manufacturer.

Perform the following procedure to remove the fan module in order to clean the fan filter, change a fan fuse or the fan module.

- 1 Loosen the thumbscrews on the front of the fan module.
- 2 Slide out the fan module.
- 3 Replace the fuse if it is burnt out (see [Appendix A on page 75](#) for fuse information). If the fuse is not the problem, use a different fan module from the manufacturer.
- 4 Slide out the fan filter. Clean or replace the filter.
- 5 Slide the fan filter back into the fan module.
- 6 Slide the fan module back into the fan module slot.
- 7 Tighten the thumbscrews.

Figure 46 IES-5000 Fan Module Thumbscrews



## 3.2 Power Maintenance

This section describes how to change the power modules.

### 3.2.1 Procedure to Disconnect the Power

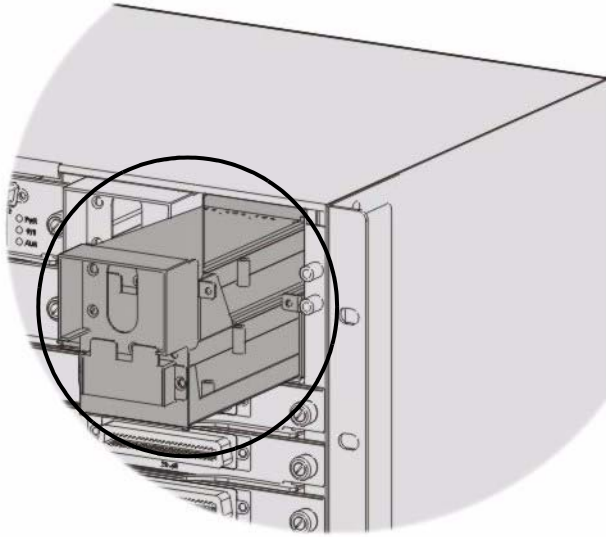
The power modules are hot-swappable and can be disconnected from the power supply individually.

- 1 Make sure that the power module you want to disconnect has the power switch in the **OFF** position.
- 2 Turn off the power supply.
- 3 Disconnect the power wires from the power supply's power terminals.
- 4 Disconnect the power wires from the IES-5000 power module terminals.

### 3.2.2 Procedure to Change a Power Module

The power modules are at the upper-right corner of the front panel of the chassis. Use the following procedure to change a power module.

- 1 Refer to [Section 3.2.1 on page 66](#) to disconnect the power before you begin.
- 2 Loosen the thumbscrews on the front panel of a power supply module.
- 3 Slide out the power supply module.
- 4 Replace any fuses that are burnt out (see [Appendix A on page 75](#) for fuse information). If the fuses are not the problem, replace the power module with a new one from the manufacturer.
- 5 Slide the power module back into the power module slot.
- 6 Tighten the thumbscrews.

**Figure 47** IES-5000 Power Module

### 3.2.3 Procedure to Reconnect the Power

- 1 Reconnect the power wires to the IES-5000's power module terminals.
- 2 Reconnect the power wires to the power supply's power terminals.
- 3 Turn the power supply back on.
- 4 Turn the IES-5000 power module switch back to the ON position.



# Hardware Troubleshooting

This section explains how to troubleshoot the system hardware.

## 4.0.1 The PWR LED Does Not Turn On

**Table 5** SYS LED Troubleshooting

STEP	CORRECTIVE ACTION
1	Make sure the power wires are properly connected to the power supply and the power supply is operating normally. Make sure you are using the correct power source. Make sure the power supply modules are turned ON. Refer to <a href="#">Appendix A on page 75</a> .
2	Make sure the chassis card is properly installed in the chassis.
	The LED itself or the unit may be faulty; contact your vendor.

## 4.0.2 The ALM LED Is On

The management switch card's ALM (alarm) LED lights when the IES-5000 is overheated and/or the fans are not working properly and/or voltage readings are outside the tolerance levels.

The ALM (alarm) LEDs on the line cards light when the card is overheated and/or voltage readings are outside the tolerance levels.

**Table 6** ALM LED Troubleshooting

STEP	CORRECTIVE ACTION
1	Go to the <b>Hardware Monitor</b> screen in the web configurator to verify the cause of the alarm. See step 2 if the unit is overheated, step 3 if the problem is with the fans and step 4 if the voltages are out of the allowed ranges.
2	Ensure that the IES-5000 is installed in a well-ventilated area and that normal operation of the fans is not inhibited. Keep the bottom, top and all sides clear of obstructions and away from the exhaust of other equipment.
3	Make sure you can feel and/or hear the fans working (working fans emit a low buzz and blow air). If the fans are not working properly, refer to <a href="#">Section 3.1 on page 65</a> for instructions on changing a fuse or changing the fan module.
4	If the voltage levels are outside the allowed range, take a screen shot of the Hardware Monitor web configurator screen and contact your vendor.

### 4.0.3 No Voice on an ADSL Connection

The ADSL line cards allow the telephone wiring used for DSL connections to also simultaneously carry normal voice conversations.

**Table 7** Voice Troubleshooting

STEP	CORRECTIVE ACTION
1	Make sure the subscriber has a POTS splitter properly installed.
2	Check the telephone wire connections between the subscriber and the MDF(s).
3	Check the telephone wire and connections between the MDF(s) and USER port(s). Refer to the pin assignments in the line card User's Guide.
4	Check the telephone wire and connections between the MDF(s) and the CO port(s). Check the telephone wire mapping on the MDF(s).
5	Check the connection from the MDF(s) to the PBX or the telephone company PSTN or ISDN switch.
6	Make sure the in-house wiring works and is connected properly.
7	Repeat the steps above using a different DSL port.

### 4.0.4 No Voice on a VoIP Connection

Check the POTS and line card connections between the subscriber, the MDF(s) and the VOP line card. See your VOP User's Guide for more information on troubleshooting VoIP problems.

### 4.0.5 Testing Wiring

Use the following tests if there is no voice.

Systematically test wiring using a functioning telephone to determine if there is a wiring problem. If the connection is good, the telephone will return a dial tone. Letters in the figure shown next indicate the systematic tests to be done. Suppose you're using installation scenario "B" as shown in the chapter on MDF connections. The logic for other scenarios should be similar.

Use steps A-D if there is no voice but you can transmit data. Use all of the steps if there is no voice and you cannot transmit data.

Figure 48 Testing In-house Wiring

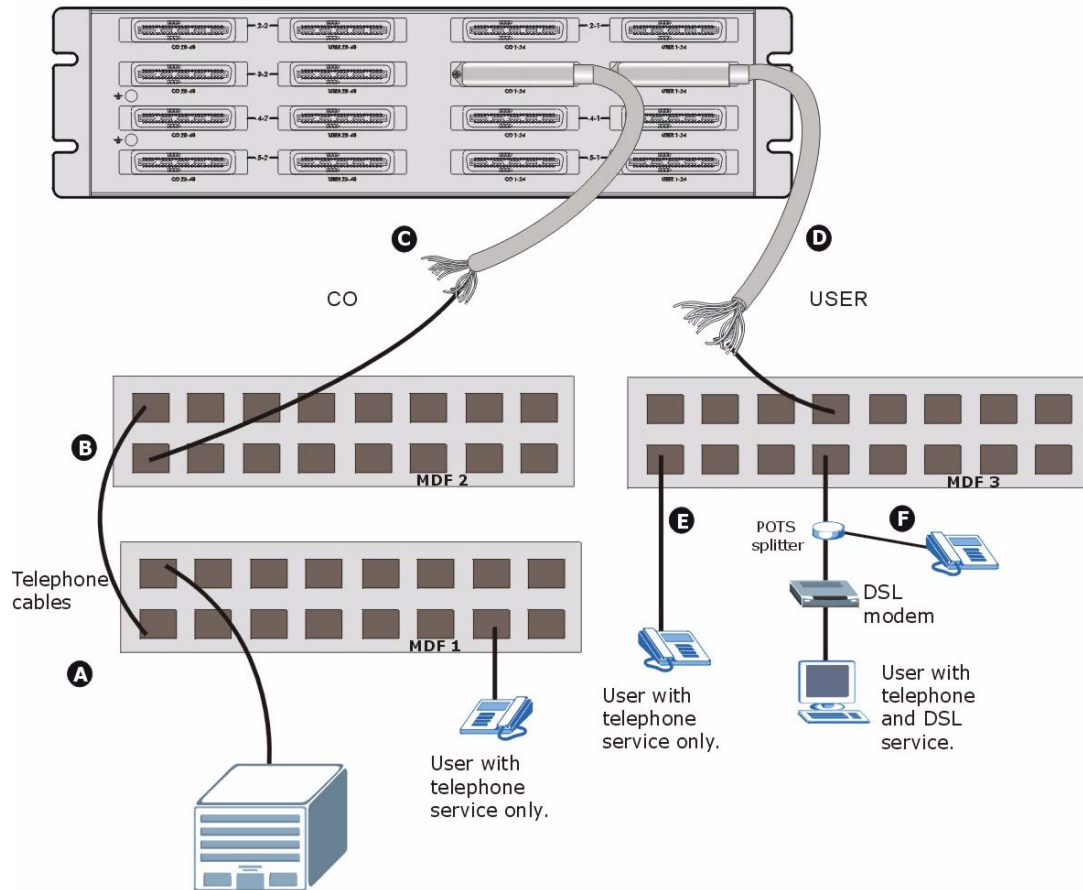


Table 8 Testing Wiring

STEP	TEST
A	<p><b>Wiring problem between the CO and MDF 1.</b></p> <p>Connect a standard telephone to MDF 1. If there is no dial tone, then a problem with the wire or wire connections between MDF 1 and the CO exists. Contact your telephone company for troubleshooting.</p>
B	<p><b>Wiring problem between MDF 1 and MDF 2.</b></p> <p>Connect a telephone to the upper port of MDF 2. If there is no dial tone, then the problem is between MDF 1 and MDF 2. Check the telephone wire and connections between MDFs 1 and 2.</p>
C	<p><b>Wiring problem between MDF 2 and the USER Telco-50 connector on the IES-5000 splitter chassis.</b></p> <p>Disconnect the Telco-50 cable from the IES-5000 splitter chassis' Telco-50 CO connector. Connect a telephone to the appropriate pins of the Telco-50 cable's Telco-50 connector. If there is no dial tone, then the problem is between the IES-5000 splitter chassis Telco-50 CO connector and MDF 2.</p> <p>Check the Telco-50 cable's pin assignments (refer to the line card User's Guide for the proper pin assignments). Replace the Telco-50 cable if the pin assignments are okay and there is still no dial tone.</p>

**Table 8** Testing Wiring

STEP	TEST
D	<p><b>Problem with a splitter card or the splitter chassis.</b></p> <p>Reconnect the Telco-50 cable to the IES-5000 splitter chassis' Telco-50 <b>CO</b> connector.</p> <p>Disconnect the Telco-50 cable from the IES-5000 splitter chassis' Telco-50 <b>USER</b> connector. Connect a telephone to the appropriate pins of the IES-5000 splitter chassis' Telco-50 <b>USER</b> connector (refer to the line card User's Guide for the proper pin assignments).</p> <p>If there is no dial tone, make sure that the splitter card is properly installed. Try a different splitter card. If using a different splitter card solves the problem, replace the first splitter card.</p> <p>If using a different splitter card does not solve the problem, the splitter chassis may be faulty, contact your vendor.</p>
E	<p><b>Wiring problem between the USER Telco-50 connector on the IES-5000 splitter chassis and MDF 3.</b></p> <p>Reconnect the Telco-50 cable to the chassis' Telco-50 <b>USER</b> connector.</p> <p>Connect a telephone to a lower port of MDF 3. If there is no dial tone, then the problem is between the chassis Telco-50 <b>USER</b> connector and MDF 3. Replace the Telco-50 cable connecting the <b>USER</b> port to MDF 3.</p> <p>If the problem remains, check the pin assignments of the USER Telco-50 connector. If the problem remains, then the IES-5000 or MDF 3 is faulty. Repeat the test in step A using MDF 3 to determine if MDF 3 has problems. Contact the telephone company if that is the case.</p> <p>If not, contact your IES-5000 vendor outlining the problem and the steps you took to solve it.</p>
F	<p><b>Building-wiring problem between the subscriber's wall jack and MDF 3.</b></p> <p>Disconnect the DSL modem from the wall jack and connect the telephone to the wall jack. If there is no dial tone, then there is a problem with the building wiring between the DSL subscriber's home and the MDF. Contact your telephone company for troubleshooting.</p>

---

# PART IV

## Appendices and Index

---

System Specifications (75)

Legal Information (79)

Customer Support (83)

Index (89)



# System Specifications

This appendix lists system features and provides detailed system specifications. See the User's Guides for individual line cards for information on card features, settings and hardware.

## Features

The following table lists key IES-5000 features.

**Table 9** Features

Slots	The IES-5000 main chassis has slots for hot-swappable DSL line cards and management switch cards.
Backplane	Connect the hot-swappable line cards and MSC cards to the backplane. The backplane is the inside rear panel of the IES-5000 main chassis.
Splitter Chassis	The splitter chassis has slots for splitter and extension cards, and Telco-50 connectors for connecting to the subscribers and the PBX (Private Branch Exchange) or PSTN/ISDN (Public Switched Telephone Network/Integrated Services Digital Network) switch.
Hot-swappable Line Cards	The IES-5000 uses hot-swappable DSL line cards.
Hot-swappable Splitter Cards	The IES-5000ST uses hot-swappable splitter cards.
Management Switch Card	The IES-5000 accommodates a management switch card that switches traffic and forwards it between the DSL line cards and other Ethernet switches.
Hot-swappable Fan Module	The IES-5000 is equipped with a hot-swappable fan module with a filter to provide easy maintenance, greater reliability and increased system operating lifetimes.
Power Modules	The IES-5000 has dual, hot-swappable power modules. One power module is redundant. The IES-5000 can be fully powered by just one power module so the system can keep running while you replace a power module.
Scalable Platform for Future Expansion	The flexible design of the IES-5000 allows service providers to start with minimum cost. As the number of users and applications increases, additional DSL line cards can be added to support more subscribers.

## System Specifications

This section provides the specifications for the IES-5000.

Main chassis dimensions	<p>IES-5000M: 440 mm (W) x 250 mm (D) x 288.9 mm (H) 6.5 U</p> <p>IES-5005M: 440 mm (W) x 250 mm (D) x 152 mm (H) 4 U</p>
Splitter chassis dimensions	<p>IES-5000ST: 440 mm (W) x 280 mm (D) x 240 mm (H) 5.4 U</p> <p>IES-5005ST: 440 mm (W) x 280 mm (D) x 125 mm (H) 2.8 U</p> <p>IES-5002ST: 440 mm (W) x 280 mm (D) x 60 mm (H) 1.5 U</p>
Chassis weight (including fan and power module weight; excluding card weights)	<p>IES-5000M: 10.0 kg</p> <p>IES-5005M: 7.0 kg</p>
Splitter chassis weight (excluding card weights)	<p>IES-5000ST: 10.4 kg</p> <p>IES-5005ST: 6.6 kg</p> <p>IES-5002ST: 4.3 kg</p>
Number of slots	<p>IES-5000M: total 10 (8 line cards and 2 management cards)</p> <p>IES-5005M: total 5 (4 line cards and 1 management card)</p> <p>IES-5000ST: 16 splitter or extension cards</p> <p>IES-5005ST: 8 splitter or extension cards</p> <p>IES-5002ST: 4 splitter or extension cards</p>
Rack mounting	The IES-5000 is 19 inch (482.6mm) rack-mountable.
Wire gauge specifications	<p>AWG (American Wire Gauge) is a measurement system for wire that specifies its thickness. As the thickness of the wire increases, the AWG number decreases.</p> <p>IES-5000M:</p> <ul style="list-style-type: none"> <li>Ground wire: 10 AWG or larger</li> <li>Telephone wire: 26 AWG or larger</li> <li>Power wire: 10 AWG or larger</li> </ul> <p>IES-5005M:</p> <ul style="list-style-type: none"> <li>Ground wire: 14 AWG or larger</li> <li>Telephone wire: 26 AWG or larger</li> <li>Power wire: 14 AWG or larger</li> </ul> <p>Note: Make sure you use wires of the specified wire gauge.</p>

Power consumption (Max)	<p>IES-5000M:  1080 Watts  30 Amps  -36 to -72 Volts DC, no tolerance</p> <p>IES-5005M:  540 Watts  15 Amps  -36 to -72 Volts DC, no tolerance</p> <p>Use a power source with 1080 W minimum output for the IES-5000M or 540 W minimum output for the IES-5005M. There is no tolerance for the input voltage.</p>
Backplane	<p>IES-5000M: The backplane has 8 1-Gigabit (SerDes) Ethernet ports.</p> <p>IES-5005M: The backplane has 4 2-Gigabit (SerDes) Ethernet ports.</p>
Telco-50 cable specifications (optional)	<p>General use:  Long: 71 cm  Short: 38 cm</p> <p>180-degree cable (for VOP-1248G splitter rear panel):  60cm</p> <p>72-port line card only:  Long: 110 cm  Medium: 93 cm  Short: 71 cm</p>
Operating Environment	<p>Temperature: -40°C ~ 65°C  Humidity: 5% - 95% (non-condensing)</p>
Storage Environment	<p>Temperature: -40°C ~ 70°C  Humidity: 5% - 95% (non-condensing)</p>
Fan modules	<p>Fan Mechanical Operation</p> <ul style="list-style-type: none"> <li>• Safe design: All fans have rotor-locking protection to prevent damage to wiring and electrical components. The fan rotors will lock when fan movement is physically obstructed.</li> <li>• Locked rotor protection: No damage will occur when the fan rotors are locked for 72 continuous hours. After this amount of time, damage to the fans may occur. The fans will automatically restart as soon as the physical obstruction is removed.</li> <li>• Polarity protection: A reverse-polarity voltage connection will not cause damage. After the polarity is corrected, the fan will restart automatically.</li> <li>• Insulation resistance: There should be more than 10M ohms of resistance between the housing and the terminal at 500 V.D.C.</li> </ul> <p>IES-5000 fan module:  Number of fans: 6  Fan dimensions: 92.0 mm (W) x 25.4 mm (D) x 92.0 mm (H)  Unit dimensions: 46.4 mm (W) x 237.0 mm (D) x 288.9 mm (H)</p> <p>IES-5005 fan module:  Number of fans: 3 (1 large and 2 small)  Fan dimensions (large): 120 mm (W) x 25 mm (D) x 120 mm (H)  Fan dimensions (small): 60 mm (W) x 20 mm (D) x 60 mm (H)  Unit dimensions: 46.4 mm (W) x 255 mm (D) x 153 mm (H)</p> <p>The fan module contains a removable filter screen for access to the fans and to clean or replace the filter.</p>

<p>Fan fuse ratings</p>	<p>IES-5000 fan module:                  Number of fuses: 1                  Type: T                  Amps: 2                  Volts AC: 250                  Dimensions: 5mm (D) x 20mm (L)</p> <p>IES-5005 fan module:                  Number of fuses: 1                  Type: T                  Amps: 1                  Volts AC: 250                  Dimensions: 5mm (D) x 20mm (L)</p>
<p>Power modules</p>	<p>IES-5000M Power Supply Module Details                  Two 600V/35A 10mm terminal blocks with dual inputs                  Built in surge protection                  Rated Voltage -48.0 VDC                  Operating Voltage: -36 ~ -72 VDC, no tolerance                  Maximum power consumption: 1080 W</p> <p>IES-5005M Power Supply Module Details                  Two 250V/15A 10mm terminal blocks with dual inputs                  Rated Voltage -48.0 VDC                  Operating Voltage: -36 to -72 VDC, no tolerance                  Maximum power consumption: 540 W</p>
<p>Power module circuit breaker and fuse ratings</p>	<p>IES-5000 power module circuit breaker                  Rated Voltage: 125V                  Rated amperage: 30A                  CSA C22.2 No5.1M and UL489 compliant</p> <p>IES-5005 power module fuses                  Number of fuses: 2                  Type: T                  Amps: 15                  Volts AC: 250                  Dimensions: 5mm (D) x 20mm (L)</p>
<p>Certifications</p>	<p>CE Conformity                  RoHS Compliance                  FCC                  ITU-T K.20                  NEBS-3                  Complies with ETSI 300019</p> <p>Safety                  IEC 60950-1                  EN 60950-1                  CSA 60950-1                  UL 60950-1</p> <p>EMC                  EN 300386                  EN 55022                  EN 61000-3-2                  EN 61000-3-3                  EN 55024</p>

# Legal Information

## Copyright

Copyright © 2007 by ZyXEL Communications Corporation.

The contents of this publication may not be reproduced in any part or as a whole, transcribed, stored in a retrieval system, translated into any language, or transmitted in any form or by any means, electronic, mechanical, magnetic, optical, chemical, photocopying, manual, or otherwise, without the prior written permission of ZyXEL Communications Corporation.

Published by ZyXEL Communications Corporation. All rights reserved.

## Disclaimer

ZyXEL does not assume any liability arising out of the application or use of any products, or software described herein. Neither does it convey any license under its patent rights nor the patent rights of others. ZyXEL further reserves the right to make changes in any products described herein without notice. This publication is subject to change without notice.

## Trademarks

ZyNOS (ZyXEL Network Operating System) is a registered trademark of ZyXEL Communications, Inc. Other trademarks mentioned in this publication are used for identification purposes only and may be properties of their respective owners.

## Certifications

### Federal Communications Commission (FCC) Interference Statement

This device complies with Part 15 of FCC rules. Operation is subject to the following two conditions:

- This device may not cause harmful interference.
- This device must accept any interference received, including interference that may cause undesired operations.

### **FCC Warning**

This device has been tested and found to comply with the limits for a Class A digital switch, pursuant to Part 15 of the FCC Rules. These limits are designed to provide reasonable protection against harmful interference in a commercial environment. This device generates, uses, and can radiate radio frequency energy and, if not installed and used in accordance with the instruction manual, may cause harmful interference to radio communications. Operation of this device in a residential area is likely to cause harmful interference in which case the user will be required to correct the interference at his own expense.

### **CE Mark Warning:**

This is a class A product. In a domestic environment this product may cause radio interference in which case the user may be required to take adequate measures.

### **Taiwanese BSMI (Bureau of Standards, Metrology and Inspection) A Warning:**

警告使用者  
這是甲類的資訊產品，在居住的環境使用時，  
可能造成射頻干擾，在這種情況下，  
使用者會被要求採取某些適當的對策。

### **Notices**

Changes or modifications not expressly approved by the party responsible for compliance could void the user's authority to operate the equipment.

This Class A digital apparatus complies with Canadian ICES-003.

Cet appareil numérique de la classe A est conforme à la norme NMB-003 du Canada.

CLASS 1 LASER PRODUCT

APPAREIL A LASER DE CLASS 1

PRODUCT COMPLIES WITH 21 CFR 1040.10 AND 1040.11.

PRODUIT CONFORME SELON 21 CFR 1040.10 ET 1040.11.

### **Viewing Certifications**

- 1 Go to <http://www.zyxel.com>.
- 2 Select your product on the ZyXEL home page to go to that product's page.
- 3 Select the certification you wish to view from this page.

## **ZyXEL Limited Warranty**

ZyXEL warrants to the original end user (purchaser) that this product is free from any defects in materials or workmanship for a period of up to two years from the date of purchase. During the warranty period, and upon proof of purchase, should the product have indications of failure due to faulty workmanship and/or materials, ZyXEL will, at its discretion, repair or replace the defective products or components without charge for either parts or labor, and to whatever extent it shall deem necessary to restore the product or components to proper operating

condition. Any replacement will consist of a new or re-manufactured functionally equivalent product of equal or higher value, and will be solely at the discretion of ZyXEL. This warranty shall not apply if the product has been modified, misused, tampered with, damaged by an act of God, or subjected to abnormal working conditions.

**Note**

Repair or replacement, as provided under this warranty, is the exclusive remedy of the purchaser. This warranty is in lieu of all other warranties, express or implied, including any implied warranty of merchantability or fitness for a particular use or purpose. ZyXEL shall in no event be held liable for indirect or consequential damages of any kind to the purchaser.

To obtain the services of this warranty, contact ZyXEL's Service Center for your Return Material Authorization number (RMA). Products must be returned Postage Prepaid. It is recommended that the unit be insured when shipped. Any returned products without proof of purchase or those with an out-dated warranty will be repaired or replaced (at the discretion of ZyXEL) and the customer will be billed for parts and labor. All repaired or replaced products will be shipped by ZyXEL to the corresponding return address, Postage Paid. This warranty gives you specific legal rights, and you may also have other rights that vary from country to country.

**Registration**

Register your product online to receive e-mail notices of firmware upgrades and information at [www.zyxel.com](http://www.zyxel.com) for global products, or at [www.us.zyxel.com](http://www.us.zyxel.com) for North American products.



# Customer Support

Please have the following information ready when you contact customer support.

## Required Information

- Product model and serial number.
- Warranty Information.
- Date that you received your device.
- Brief description of the problem and the steps you took to solve it.

“+” is the (prefix) number you dial to make an international telephone call.

## Corporate Headquarters (Worldwide)

- Support E-mail: [support@zyxel.com.tw](mailto:support@zyxel.com.tw)
- Sales E-mail: [sales@zyxel.com.tw](mailto:sales@zyxel.com.tw)
- Telephone: +886-3-578-3942
- Fax: +886-3-578-2439
- Web: [www.zyxel.com](http://www.zyxel.com), [www.europe.zyxel.com](http://www.europe.zyxel.com)
- FTP: [ftp.zyxel.com](ftp://ftp.zyxel.com), [ftp.europe.zyxel.com](ftp://ftp.europe.zyxel.com)
- Regular Mail: ZyXEL Communications Corp., 6 Innovation Road II, Science Park, Hsinchu 300, Taiwan

## Costa Rica

- Support E-mail: [soporte@zyxel.co.cr](mailto:soporte@zyxel.co.cr)
- Sales E-mail: [sales@zyxel.co.cr](mailto:sales@zyxel.co.cr)
- Telephone: +506-2017878
- Fax: +506-2015098
- Web: [www.zyxel.co.cr](http://www.zyxel.co.cr)
- FTP: [ftp.zyxel.co.cr](ftp://ftp.zyxel.co.cr)
- Regular Mail: ZyXEL Costa Rica, Plaza Roble Escazú, Etapa El Patio, Tercer Piso, San José, Costa Rica

## Czech Republic

- E-mail: [info@cz.zyxel.com](mailto:info@cz.zyxel.com)
- Telephone: +420-241-091-350
- Fax: +420-241-091-359
- Web: [www.zyxel.cz](http://www.zyxel.cz)

- Regular Mail: ZyXEL Communications, Czech s.r.o., Modranská 621, 143 01 Praha 4 - Modrany, Česká Republika

### **Denmark**

- Support E-mail: support@zyxel.dk
- Sales E-mail: sales@zyxel.dk
- Telephone: +45-39-55-07-00
- Fax: +45-39-55-07-07
- Web: www.zyxel.dk
- Regular Mail: ZyXEL Communications A/S, Columbusvej, 2860 Soeborg, Denmark

### **Finland**

- Support E-mail: support@zyxel.fi
- Sales E-mail: sales@zyxel.fi
- Telephone: +358-9-4780-8411
- Fax: +358-9-4780-8448
- Web: www.zyxel.fi
- Regular Mail: ZyXEL Communications Oy, Malminkaari 10, 00700 Helsinki, Finland

### **France**

- E-mail: info@zyxel.fr
- Telephone: +33-4-72-52-97-97
- Fax: +33-4-72-52-19-20
- Web: www.zyxel.fr
- Regular Mail: ZyXEL France, 1 rue des Vergers, Bat. 1 / C, 69760 Limonest, France

### **Germany**

- Support E-mail: support@zyxel.de
- Sales E-mail: sales@zyxel.de
- Telephone: +49-2405-6909-69
- Fax: +49-2405-6909-99
- Web: www.zyxel.de
- Regular Mail: ZyXEL Deutschland GmbH., Adenauerstr. 20/A2 D-52146, Wuerselen, Germany

### **Hungary**

- Support E-mail: support@zyxel.hu
- Sales E-mail: info@zyxel.hu
- Telephone: +36-1-3361649
- Fax: +36-1-3259100
- Web: www.zyxel.hu
- Regular Mail: ZyXEL Hungary, 48, Zoldlomb Str., H-1025, Budapest, Hungary

**India**

- Support E-mail: support@zyxel.in
- Sales E-mail: sales@zyxel.in
- Telephone: +91-11-30888144 to +91-11-30888153
- Fax: +91-11-30888149, +91-11-26810715
- Web: <http://www.zyxel.in>
- Regular Mail: India - ZyXEL Technology India Pvt Ltd., II-Floor, F2/9 Okhla Phase -1, New Delhi 110020, India

**Japan**

- Support E-mail: support@zyxel.co.jp
- Sales E-mail: zyp@zyxel.co.jp
- Telephone: +81-3-6847-3700
- Fax: +81-3-6847-3705
- Web: [www.zyxel.co.jp](http://www.zyxel.co.jp)
- Regular Mail: ZyXEL Japan, 3F, Office T&U, 1-10-10 Higashi-Gotanda, Shinagawa-ku, Tokyo 141-0022, Japan

**Kazakhstan**

- Support: <http://zyxel.kz/support>
- Sales E-mail: sales@zyxel.kz
- Telephone: +7-3272-590-698
- Fax: +7-3272-590-689
- Web: [www.zyxel.kz](http://www.zyxel.kz)
- Regular Mail: ZyXEL Kazakhstan, 43 Dostyk Ave., Office 414, Dostyk Business Centre, 050010 Almaty, Republic of Kazakhstan

**Malaysia**

- Support E-mail: support@zyxel.com.my
- Sales E-mail: sales@zyxel.com.my
- Telephone: +603-8076-9933
- Fax: +603-8076-9833
- Web: <http://www.zyxel.com.my>
- Regular Mail: ZyXEL Malaysia Sdn Bhd., 1-02 & 1-03, Jalan Kenari 17F, Bandar Puchong Jaya, 47100 Puchong, Selangor Darul Ehsan, Malaysia

**North America**

- Support E-mail: support@zyxel.com
- Sales E-mail: sales@zyxel.com
- Telephone: +1-800-255-4101, +1-714-632-0882
- Fax: +1-714-632-0858
- Web: [www.us.zyxel.com](http://www.us.zyxel.com)
- FTP: <ftp.us.zyxel.com>

- Regular Mail: ZyXEL Communications Inc., 1130 N. Miller St., Anaheim, CA 92806-2001, U.S.A.

### **Norway**

- Support E-mail: support@zyxel.no
- Sales E-mail: sales@zyxel.no
- Telephone: +47-22-80-61-80
- Fax: +47-22-80-61-81
- Web: www.zyxel.no
- Regular Mail: ZyXEL Communications A/S, Nils Hansens vei 13, 0667 Oslo, Norway

### **Poland**

- E-mail: info@pl.zyxel.com
- Telephone: +48-22-333 8250
- Fax: +48-22-333 8251
- Web: www.pl.zyxel.com
- Regular Mail: ZyXEL Communications, ul. Okrzei 1A, 03-715 Warszawa, Poland

### **Russia**

- Support: <http://zyxel.ru/support>
- Sales E-mail: sales@zyxel.ru
- Telephone: +7-095-542-89-29
- Fax: +7-095-542-89-25
- Web: www.zyxel.ru
- Regular Mail: ZyXEL Russia, Ostrovityanova 37a Str., Moscow 117279, Russia

### **Singapore**

- Support E-mail: support@zyxel.com.sg
- Sales E-mail: sales@zyxel.com.sg
- Telephone: +65-6899-6678
- Fax: +65-6899-8887
- Web: <http://www.zyxel.com.sg>
- Regular Mail: ZyXEL Singapore Pte Ltd., No. 2 International Business Park, The Strategy #03-28, Singapore 609930

### **Spain**

- Support E-mail: support@zyxel.es
- Sales E-mail: sales@zyxel.es
- Telephone: +34-902-195-420
- Fax: +34-913-005-345
- Web: www.zyxel.es
- Regular Mail: ZyXEL Communications, Arte, 21 5ª planta, 28033 Madrid, Spain

**Sweden**

- Support E-mail: support@zyxel.se
- Sales E-mail: sales@zyxel.se
- Telephone: +46-31-744-7700
- Fax: +46-31-744-7701
- Web: www.zyxel.se
- Regular Mail: ZyXEL Communications A/S, Sjöporten 4, 41764 Göteborg, Sweden

**Thailand**

- Support E-mail: support@zyxel.co.th
- Sales E-mail: sales@zyxel.co.th
- Telephone: +662-831-5315
- Fax: +662-831-5395
- Web: <http://www.zyxel.co.th>
- Regular Mail: ZyXEL Thailand Co., Ltd., 1/1 Moo 2, Ratchaphruk Road, Bangrak-Noi, Muang, Nonthaburi 11000, Thailand.

**Ukraine**

- Support E-mail: support@ua.zyxel.com
- Sales E-mail: sales@ua.zyxel.com
- Telephone: +380-44-247-69-78
- Fax: +380-44-494-49-32
- Web: www.ua.zyxel.com
- Regular Mail: ZyXEL Ukraine, 13, Pimonenko Str., Kiev 04050, Ukraine

**United Kingdom**

- Support E-mail: support@zyxel.co.uk
- Sales E-mail: sales@zyxel.co.uk
- Telephone: +44-1344-303044, 08707-555779 (UK only)
- Fax: +44-1344-303034
- Web: www.zyxel.co.uk
- FTP: ftp.zyxel.co.uk
- Regular Mail: ZyXEL Communications UK Ltd., 11 The Courtyard, Eastern Road, Bracknell, Berkshire RG12 2XB, United Kingdom (UK)



# Index

## A

airflow [28](#)

## B

backplane [77](#)

bracket [28](#)

## C

card installation [30](#)

certifications [79](#)

notices [80](#)

viewing [80](#)

chassis installation [27](#)

contact information [83](#)

copyright [79](#)

customer support [83](#)

## D

data signals [46](#)

disclaimer [79](#)

## E

earthing terminals [29](#)

ejector levers [30, 32](#)

exhaust [28](#)

exhaust vents [28](#)

## F

fan exhaust vents [28](#)

fan intake vents [28](#)

fan maintenance [65](#)

FCC interference statement [79](#)

frame ground [29](#)

## G

ground [29](#)

wire gauge [76](#)

## I

installation [27](#)

installation requirements [27](#)

installing a splitter chassis card [33](#)

installing cards [30](#)

intake vents [28](#)

## L

levers [30, 32](#)

line card connections [36, 38, 41](#)

## M

main chassis

specifications [75](#)

Main Distribution Frame [44](#)

maintenance

fan [65](#)

power [66](#)

MDF connections [44](#)

MDF scenarios [46](#)

mounting bracket [28](#)

Multiple Tenant Unit [21](#)

## P

power connections [53](#)  
power maintenance [66](#)  
product registration [81](#)  
Punch-down Tool [45](#)

## R

rack-mounted installation [27](#)  
registration  
  product [81](#)  
related documentation [3](#)  
removing a splitter chassis card [35](#)

## S

safety warnings [6](#)  
screwdriver [27](#)  
specifications [75](#)  
splitter chassis card installation [33](#)  
splitter chassis card removal [35](#)  
syntax conventions [4](#)

## T

Telco-50 cables [45](#)  
telephone wire  
  gauge [76](#)  
thumbscrews [30](#), [32](#), [34](#), [35](#)  
trademarks [79](#)

## V

vents [28](#)  
voice signals [46](#)  
VOP card [42](#)

## W

warranty [80](#)  
  note [81](#)  
wire  
  power [56](#), [59](#)