

V300 Series

IP Phone

User's Guide

Default Login Details

IP Address	dhcp
User Name	admin
Password	1234

Firmware Version 1.20
Edition 1, 05/2010

www.zyxel.com

The logo for ZyXEL, featuring the brand name in a bold, blue, sans-serif font. The 'Z' and 'Y' are connected, and the 'X' is stylized with a diagonal slash.

About This User's Guide

Intended Audience

This manual is intended for people who want to configure the V300 using the LCD screen and/or web configurator. You should have at least a basic knowledge of TCP/IP networking concepts and topology.

Related Documentation

- Quick Start Guide

The Quick Start Guide is designed to help you get up and running right away. It contains information on setting up and configuring the V300.

- Web Configurator Online Help

Embedded web help for descriptions of individual screens and supplementary information.

- Support Disc

Refer to the included CD for support documents.

- ZyXEL Web Site

Please refer to www.zyxel.com for additional support documentation and product certifications.

User's Guide Feedback

Help us help you. Send all User's Guide-related comments, questions or suggestions for improvement to the following address, or use e-mail instead. Thank you!

The Technical Writing Team,
ZyXEL Communications Corp.,
6 Innovation Road II,
Science-Based Industrial Park,
Hsinchu, 300, Taiwan.

E-mail: techwriters@zyxel.com.tw

Document Conventions

Warnings and Notes

These are how warnings and notes are shown in this User's Guide.

Warnings tell you about things that could harm you or your device.









Note: Notes tell you other important information (for example, other things you may need to configure or helpful tips) or recommendations.

Syntax Conventions

- The V300 or V301 may be referred to as the "V300", the "device", the "system" or the "product" in this User's Guide.
- Product labels, screen names, field labels and field choices are all in **bold** font.
- A key stroke is denoted by square brackets and uppercase text, for example, [ENTER] means the "enter" or "return" key on your keyboard.
- "Enter" means for you to type one or more characters and then press the [ENTER] key. "Select" or "choose" means for you to use one of the predefined choices.
- A right angle bracket (>) within a screen name denotes a mouse click. For example, **Maintenance > Log > Log Setting** means you first click **Maintenance** in the navigation panel, then the **Log** sub menu and finally the **Log Setting** tab to get to that screen.
- Units of measurement may denote the "metric" value or the "scientific" value. For example, "k" for kilo may denote "1000" or "1024", "M" for mega may denote "1000000" or "1048576" and so on.
- "e.g.," is a shorthand for "for instance", and "i.e.," means "that is" or "in other words".

Icons Used in Figures

Figures in this User's Guide may use the following generic icons. The V300 icon is not an exact representation of your device.

V300 	Computer 	Notebook computer 
Server 	DSLAM 	Firewall 
Telephone 	Switch 	Router 

Safety Warnings

For your safety, be sure to read and follow all warning notices and instructions.

- Do NOT use this product near water, for example, in a wet basement or near a swimming pool.
- Do NOT expose your device to dampness, dust or corrosive liquids.
- Do NOT store things on the device.
- Do NOT install, use, or service this device during a thunderstorm. There is a remote risk of electric shock from lightning.
- Connect ONLY suitable accessories to the device.
- Do NOT open the device or unit. Opening or removing covers can expose you to dangerous high voltage points or other risks. ONLY qualified service personnel should service or disassemble this device. Please contact your vendor for further information.
- Make sure to connect the cables to the correct ports.
- Place connecting cables carefully so that no one will step on them or stumble over them.
- Always disconnect all cables from this device before servicing or disassembling.
- Use ONLY an appropriate power adaptor or cord for your device. Connect it to the right supply voltage (for example, 110V AC in North America or 230V AC in Europe).
- Do NOT allow anything to rest on the power adaptor or cord and do NOT place the product where anyone can walk on the power adaptor or cord.
- Do NOT use the device if the power adaptor or cord is damaged as it might cause electrocution.
- If the power adaptor or cord is damaged, remove it from the device and the power source.
- Do NOT attempt to repair the power adaptor or cord. Contact your local vendor to order a new one.
- Do not use the device outside, and make sure all the connections are indoors. There is a remote risk of electric shock from lightning.
- Do NOT obstruct the device ventilation slots, as insufficient airflow may harm your device.
- If you wall mount your device, make sure that no electrical lines, gas or water pipes will be damaged.
- The PoE (Power over Ethernet) devices that supply or receive power and their connected Ethernet cables must all be completely indoors.

This product is recyclable. Dispose of it properly.



Contents Overview

User's Guide	25
Introducing the V300	27
Hardware	31
Technical Reference	43
Using the LCD Screen	45
The Phonebook	51
LCD Menus: Basic Settings	53
LCD Menus: Advanced	59
The Web Configurator	83
The Status Screens	89
Network Setup	97
SIP Account Setup	101
Phone Setup	119
The Phone Book	127
System	137
Logs	145
Tools	147
Troubleshooting	157

Table of Contents

About This User's Guide	3
Document Conventions.....	4
Safety Warnings.....	6
Contents Overview	9
Table of Contents.....	11
List of Figures	17
List of Tables.....	23
Part I: User's Guide.....	25
Chapter 1	
Introducing the V300	27
1.1 Overview	27
1.2 Applications	28
1.2.1 Make Calls via Internet Telephony Service Provider	28
1.2.2 Make Calls via IP-PBX	28
1.2.3 Make Peer-to-peer Calls	29
1.3 Ways to Manage the V300	29
1.4 Good Habits for Managing the V300	30
Chapter 2	
Hardware.....	31
2.1 Overview	31
2.2 Physical Features	32
2.2.1 The LCD Screen	37
2.2.2 Resetting the V300	37
2.3 Phone Functions	37
2.3.1 Making a Call	37
2.3.2 Receiving a Call	38
2.3.3 Ending a Call	38
2.3.4 Changing the Volume	38
2.3.5 Muting a Call	39
2.3.6 Placing a Call on Hold	39

2.3.7 Using Voicemail	39
2.3.8 Making Conference Calls	39
2.3.9 Transferring a Call	41
2.3.10 Upgrading the Phone's Firmware	41
Part II: Technical Reference	43
Chapter 3	
Using the LCD Screen	45
3.1 Overview	45
3.2 Navigation	45
3.3 Enabling and Disabling Features	46
3.4 Entering Numbers, Letters and Symbols	46
3.5 LCD Menu Overview	47
3.6 The LCD Status Screen	49
Chapter 4	
The Phonebook	51
4.1 Overview	51
4.1.1 What You Can Do in This Chapter	51
4.2 Add a Phonebook Entry	51
4.3 Call a Phonebook Contact	52
4.4 Calling a Number Not in the Phonebook	52
Chapter 5	
LCD Menus: Basic Settings	53
5.1 Overview	53
5.1.1 What You Can Do in This Chapter	53
5.2 Entering the Menu System	53
5.3 The Phonebook Menu	54
5.4 The Volume Setting Menu	54
5.4.1 Volume Screen	55
5.5 The System Info Menu	55
5.6 The Advanced Setting Menu	56
5.7 The Reset Menu	56
5.7.1 System Restart	56
5.7.2 Load Factory Default	56
Chapter 6	
LCD Menus: Advanced	59
6.1 Overview	59

6.1.1 What You Can Do in This Chapter	59
6.1.2 What You Need to Know	60
6.2 The Advanced Setting Menu	60
6.3 The VoIP Menus	60
6.3.1 SIP Active	61
6.3.2 SIP Number	62
6.3.3 SIP Server Address	63
6.3.4 SIP Server Port	63
6.3.5 SIP Register Server	64
6.3.6 SIP Register Port	65
6.3.7 SIP Service Domain	65
6.3.8 SIP User ID	66
6.3.9 SIP Password	67
6.4 The Auto Provision Menu	67
6.4.1 Auto Provision Active	68
6.4.2 Protocol	68
6.4.3 Auto Provisioning Server Address	69
6.4.4 Server Port	70
6.4.5 Expire Time	70
6.4.6 Retry Time	70
6.5 DHCP	71
6.6 The Static IP Menu	71
6.6.1 IP Address	72
6.6.2 Gateway	73
6.6.3 Subnet Mask	73
6.6.4 First and Second DNS Servers	74
6.7 The PPPoE Menu	74
6.7.1 PPPoE Username	75
6.7.2 PPPoE Password	76
6.8 The VLAN Menu	76
6.9 LCD Contrast	77
6.10 Ring Setting	78
6.11 Flexworker Mode	78
6.11.1 Using Flexworker Mode	78
6.12 Clock Alarm	80
6.13 Time Zone	80
6.14 Date Format	80
Chapter 7	
The Web Configurator	83
7.1 Overview	83
7.2 Accessing the Web Configurator	83
7.2.1 Title Bar	86

7.2.2 Navigation Panel	86
7.2.3 Main Window	87
7.2.4 Status Bar	87
Chapter 8	
The Status Screens.....	89
8.1 Overview	89
8.1.1 What You Can Do in this Chapter	89
8.2 Status Screen	90
8.3 Packet Statistics	92
8.4 VoIP Statistics	93
Chapter 9	
Network Setup.....	97
9.1 Overview	97
9.1.1 What You Can Do in This Chapter	97
9.1.2 What You Need to Know About Network Setup	97
9.2 Internet Connection	99
9.3 Management Port	100
Chapter 10	
SIP Account Setup.....	101
10.1 Overview	101
10.1.1 What You Can Do in This Chapter	101
10.1.2 What You Need to Know About Network Setup	101
10.2 The SIP Settings Screen	109
10.2.1 Advanced SIP Setup Screen	113
10.3 SIP QoS Screen	117
Chapter 11	
Phone Setup.....	119
11.1 Overview	119
11.2 What You Can Do in This Chapter	119
11.3 Phone Settings Screen	120
11.3.1 Voice Activity Detection/Silence Suppression	123
11.3.2 Comfort Noise Generation	123
11.4 Phone Region Screen	123
11.5 Speed Dial Settings Screen	124
11.6 Programmable Feature Key Settings Screen	125
Chapter 12	
The Phone Book.....	127
12.1 Overview	127

12.1.1 What You Can Do in This Chapter	127
12.2 Call Forward Screen	127
12.3 Contact List Screen	130
12.4 Group List Screen	131
12.5 Block List Screen	133
12.6 DND White List Screen	135
Chapter 13	
System	137
13.1 Overview	137
13.2 What You Can Do in This Chapter	137
13.3 General Screen	138
13.4 Time Setting Screen	140
13.5 Dynamic DNS	142
13.6 Clock Alarm Setting	144
Chapter 14	
Logs	145
14.1 Overview	145
14.2 Logs Screen	145
14.3 SIP Message	146
Chapter 15	
Tools.....	147
15.1 Overview	147
15.1.1 What You Can Do in This Chapter	147
15.2 Firmware Screen	147
15.3 Configuration Screen	150
15.3.1 Backup Configuration	150
15.3.2 Restore Configuration	150
15.3.3 Save Debug Log	152
15.3.4 Back to Factory Defaults	152
15.4 Restart Screen	152
15.5 Ring Maintenance Screen	153
15.6 Packet Mirror Screen	154
Chapter 16	
Troubleshooting.....	157
16.1 Overview	157
16.2 Power, Hardware Connections, and LEDs	157
16.3 Internet Access	160
16.4 Phone Calls and VoIP	161

Appendix A Product Specifications..... 165

Appendix B Setting Up Your Computer's IP Address 171

Appendix C Pop-up Windows, JavaScripts and Java Permissions 201

Appendix D IP Addresses and Subnetting 209

Appendix E Legal Information 219

Appendix F Open Software Announcements 223

Appendix G Customer Support 229

Index..... 235

List of Figures

Figure 1 Internet Telephony Service Provider Application	28
Figure 2 IP-PBX Application	29
Figure 3 Peer-to-peer Calling	29
Figure 4 Front Panel Hardware	32
Figure 5 Side Panel	34
Figure 6 Rear Panel	35
Figure 7 Base Panel Hardware	36
Figure 8 Example: DHCP	46
Figure 9 LCD Status Screen	49
Figure 10 Flexworker Icon	49
Figure 11 LCD Contact Record	51
Figure 12 LCD Contact Record: Save	52
Figure 13 LCD Dial Screen	52
Figure 14 LCD Contact List Screen	52
Figure 15 LCD Menu Setting	53
Figure 16 LCD Menu: Phonebook.....	54
Figure 17 LCD Menu: Volume Setting	54
Figure 18 LCD Menu: Volume Screen	55
Figure 19 LCD Menu: System Info	55
Figure 20 LCD Menu: Reset	56
Figure 21 LCD Menu: Reset: System Restart	56
Figure 22 LCD Menu: Reset: System Restart: Confirm	56
Figure 23 LCD Menu: Reset: Reset Default	56
Figure 24 LCD Menu: Reset: Reset Default: Confirm	57
Figure 25 LCD Menu: Advanced Setting.....	60
Figure 26 LCD Menu: Admin Password Entry	61
Figure 27 LCD Menu: SIP Active.....	61
Figure 28 LCD Menu: SIP Active.....	62
Figure 29 LCD Menu: SIP Number.....	62
Figure 30 LCD Menu: SIP Number - Edit.....	62
Figure 31 LCD Menu: SIP Server Address.....	63
Figure 32 LCD Menu: SIP Server Address - Edit.....	63
Figure 33 LCD Menu: SIP Server Port.....	63
Figure 34 LCD Menu: SIP Server Port - Edit.....	64
Figure 35 LCD Menu: SIP Register Server	64
Figure 36 LCD Menu: SIP Register Server Address - Edit.....	64
Figure 37 LCD Menu: SIP Register Port	65
Figure 38 LCD Menu: SIP Register Port - Edit.....	65

Figure 39 LCD Menu: SIP Service Domain	65
Figure 40 LCD Menu: SIP Service Domain - Edit.....	66
Figure 41 LCD Menu: SIP User ID	66
Figure 42 LCD Menu: SIP User ID - Edit.....	66
Figure 43 LCD Menu: Authentication Password.....	67
Figure 44 LCD Menu: Authentication Password - Edit	67
Figure 45 LCD Menu: Admin Password Entry	67
Figure 46 LCD Menu: DHCP	68
Figure 47 LCD Menu: DHCP	68
Figure 48 LCD Menu: Protocol	68
Figure 49 LCD Menu: Serv Addr	69
Figure 50 LCD Menu: Serv Addr Error	69
Figure 51 LCD Menu: Serv Port	70
Figure 52 LCD Menu: Expire Time	70
Figure 53 LCD Menu: Retry Time	70
Figure 54 LCD Menu: DHCP	71
Figure 55 LCD Menu: Static IP	71
Figure 56 LCD Menu: IP Address.....	72
Figure 57 LCD Menu: IP Address - Edit	72
Figure 58 LCD Menu: Gateway	73
Figure 59 LCD Menu: Gateway - Edit.....	73
Figure 60 LCD Menu: Subnet Mask	73
Figure 61 LCD Menu: Subnet Mask - Edit	73
Figure 62 LCD Menu: First / Second DNS	74
Figure 63 LCD Menu: First / Second DNS - Edit	74
Figure 64 LCD Menu: PPPoE	75
Figure 65 LCD Menu: PPPoE Username	75
Figure 66 LCD Menu: PPPoE Username - Edit	75
Figure 67 LCD Menu: PPPoE Password.....	76
Figure 68 LCD Menu: PPPoE Password - Edit	76
Figure 69 LCD Menu: VLAN	77
Figure 70 LCD Menu: LCD Contrast	77
Figure 71 LCD Menu: Ring Type	78
Figure 72 LCD Menu: Flexworker Mode	78
Figure 73 LCD Menu: Clock Alarm	80
Figure 74 LCD Menu: Time Zone	80
Figure 75 LCD Menu: Date Format	81
Figure 76 Password Screen	83
Figure 77 Change Password Screen	84
Figure 78 The Status Screen	85
Figure 79 Status Screen	90
Figure 80 Packet Statistics	92
Figure 81 VoIP Statistics	93

Figure 82 Network > Internet Connection	99
Figure 83 Network > Mgnt Port	100
Figure 84 SIP User Agent	103
Figure 85 SIP Proxy Server	104
Figure 86 SIP Redirect Server	105
Figure 87 STUN	106
Figure 88 DiffServ: Differentiated Service Field	108
Figure 89 VoIP > SIP > SIP Settings	110
Figure 90 VoIP > SIP > SIP Settings > Advanced	113
Figure 91 VoIP > SIP > QoS	117
Figure 92 VoIP > Phone > Phone Settings	120
Figure 93 VoIP > Phone > Region	123
Figure 94 Phone Book > Speed Dial	124
Figure 95 Phone Book > Programmable Feature Key Settings	125
Figure 96 VoIP > Phone Book > Call Forward	128
Figure 97 VoIP > Phone Book > Contact List	130
Figure 98 VoIP > Phone Book > Group List	132
Figure 99 VoIP > Phone Book > Block List	133
Figure 100 VoIP > Phone Book > DND White List	135
Figure 101 Maintenance > System > General	138
Figure 102 Maintenance > Time Setting	140
Figure 103 Maintenance > DDNS	143
Figure 104 Maintenance > System > Clock Alarm Setting	144
Figure 105 Maintenance > Logs	145
Figure 106 Maintenance > SIP Message	146
Figure 107 Maintenance > Tools > Firmware Upload	148
Figure 108 Upload Warning	148
Figure 109 Network Temporarily Disconnected	149
Figure 110 Upload Error Message	149
Figure 111 Maintenance > Tools > Configuration	150
Figure 112 Configuration Upload Successful	151
Figure 113 Temporarily Disconnected	151
Figure 114 Configuration Restore Error	152
Figure 115 Maintenance > Tools > Restart	152
Figure 116 Maintenance > Tools > Ring Maintenance	153
Figure 117 Packet Mirror Example	154
Figure 118 Maintenance > Tools > Packet Mirror	154
Figure 119 Wall-mounting Example	169
Figure 120 Masonry Plug and M4 Tap Screw	169
Figure 121 Windows XP: Start Menu	172
Figure 122 Windows XP: Control Panel	172
Figure 123 Windows XP: Control Panel > Network Connections > Properties	173
Figure 124 Windows XP: Local Area Connection Properties	173

Figure 125 Windows XP: Internet Protocol (TCP/IP) Properties	174
Figure 126 Windows Vista: Start Menu	176
Figure 127 Windows Vista: Control Panel	176
Figure 128 Windows Vista: Network And Internet	176
Figure 129 Windows Vista: Network and Sharing Center	177
Figure 130 Windows Vista: Network and Sharing Center	177
Figure 131 Windows Vista: Local Area Connection Properties	178
Figure 132 Windows Vista: Internet Protocol Version 4 (TCP/IPv4) Properties	179
Figure 133 Mac OS X 10.4: Apple Menu	181
Figure 134 Mac OS X 10.4: System Preferences	181
Figure 135 Mac OS X 10.4: Network Preferences	182
Figure 136 Mac OS X 10.4: Network Preferences > TCP/IP Tab.	182
Figure 137 Mac OS X 10.4: Network Preferences > Ethernet	183
Figure 138 Mac OS X 10.4: Network Utility	184
Figure 139 Mac OS X 10.5: Apple Menu	185
Figure 140 Mac OS X 10.5: Systems Preferences	185
Figure 141 Mac OS X 10.5: Network Preferences > Ethernet	186
Figure 142 Mac OS X 10.5: Network Preferences > Ethernet	187
Figure 143 Mac OS X 10.5: Network Utility	188
Figure 144 Ubuntu 8: System > Administration Menu	189
Figure 145 Ubuntu 8: Network Settings > Connections	189
Figure 146 Ubuntu 8: Administrator Account Authentication	190
Figure 147 Ubuntu 8: Network Settings > Connections	190
Figure 148 Ubuntu 8: Network Settings > Properties	191
Figure 149 Ubuntu 8: Network Settings > DNS	192
Figure 150 Ubuntu 8: Network Tools	193
Figure 151 openSUSE 10.3: K Menu > Computer Menu	194
Figure 152 openSUSE 10.3: K Menu > Computer Menu	195
Figure 153 openSUSE 10.3: YaST Control Center	195
Figure 154 openSUSE 10.3: Network Settings	196
Figure 155 openSUSE 10.3: Network Card Setup	197
Figure 156 openSUSE 10.3: Network Settings	198
Figure 157 openSUSE 10.3: KNetwork Manager	199
Figure 158 openSUSE: Connection Status - KNetwork Manager	199
Figure 159 Pop-up Blocker	201
Figure 160 Internet Options: Privacy	202
Figure 161 Internet Options: Privacy	203
Figure 162 Pop-up Blocker Settings	204
Figure 163 Internet Options: Security	205
Figure 164 Security Settings - Java Scripting	206
Figure 165 Security Settings - Java	207
Figure 166 Java (Sun)	208
Figure 167 Network Number and Host ID	210

Figure 168 Subnetting Example: Before Subnetting 213
Figure 169 Subnetting Example: After Subnetting 214

List of Tables

Table 1 Models Covered	27
Table 2 Front Panel Hardware	33
Table 3 Side Panel Hardware	35
Table 4 Rear Panel Hardware	36
Table 5 Base Panel Hardware	36
Table 6 Keypad Characters	47
Table 7 LCD Menu Overview	47
Table 8 LCD Menu: Volume Setting	54
Table 9 LCD Menu: System Info	55
Table 10 LCD Menu: SIP Account Configuration	61
Table 11 LCD Menu: SIP Account Configuration	68
Table 12 LCD Menu: Static IP	69
Table 13 LCD Menu: Static IP	71
Table 14 LCD Menu: SIP Account Configuration	72
Table 15 LCD Menu: PPPoE	75
Table 16 LCD Menu: SIP Account Configuration	75
Table 17 LCD Menu: VLAN	77
Table 18 Web Configurator Icons in the Title Bar	86
Table 19 Navigation Panel Summary	86
Table 20 Status Screen	90
Table 21 Packet Statistics	92
Table 22 VoIP Statistics	94
Table 23 Private IP Address Ranges	97
Table 24 Network > Internet Connection	99
Table 25 Network > Mgnt Port	100
Table 26 SIP Call Progression	102
Table 27 VoIP > SIP > SIP Settings	111
Table 28 VoIP > SIP > SIP Settings > Advanced Setup	114
Table 29 VoIP > SIP > QoS	117
Table 30 VoIP > Phone > Phone Settings	121
Table 31 VoIP > Phone > Region	123
Table 32 Phone Book > Speed Dial	124
Table 33 Phone Book > Programmable Feature Key Settings	125
Table 34 VoIP > Phone Book > Call Forward	128
Table 35 VoIP > Phone Book > Contact List	130
Table 36 VoIP > Phone Book > Group List	132
Table 37 VoIP > Phone Book > Block List	133
Table 38 VoIP > Phone Book > DND White List	136

Table 39 Maintenance > System > General	138
Table 40 Maintenance > Time Setting	140
Table 41 Maintenance > System > DDNS	143
Table 42 Maintenance > System > Clock Alarm Setting	144
Table 43 Maintenance > Logs	145
Table 44 Maintenance > SIP Message	146
Table 45 Maintenance > Tools > Firmware Upload	148
Table 46 Maintenance > Tools > Configuration > Restore	150
Table 47 Maintenance > Tools > Ring Maintenance	153
Table 48 Maintenance > Tools > Ring Maintenance	155
Table 49 Hardware Specifications	165
Table 50 Firmware Specifications	166
Table 51 Standards Supported	167
Table 52 IP Address Network Number and Host ID Example	210
Table 53 Subnet Masks	211
Table 54 Maximum Host Numbers	211
Table 55 Alternative Subnet Mask Notation	212
Table 56 Subnet 1	215
Table 57 Subnet 2	215
Table 58 Subnet 3	215
Table 59 Subnet 4	215
Table 60 Eight Subnets	216
Table 61 24-bit Network Number Subnet Planning	216
Table 62 16-bit Network Number Subnet Planning	217
Table 63 Open Source Components	227

PART I

User's Guide

Introducing the V300

1.1 Overview

This chapter introduces the main applications and features of the V300. It also introduces the ways you can manage the V300.

The V300 is an IP phone that allows you to make phone calls over the Internet. Sending voice signals over the Internet is called Voice over IP (VoIP). VoIP allows you to call other IP phones, mobile phones or landlines all over the world.

The V300 is packed with features - including multiple lines, phonebook, conference calls, call transfer, call hold, and many more.

You can configure and manage the V300 directly, using its multi-function keypad and LCD screen. Alternatively, access the internal web configurator using a computer connected to the network for remote administrative configuration.

The V300's Ethernet ports allow you to connect it to your Local Area Network (LAN) and your computer. Your computer can access the LAN through the V300, as shown in the following figure. **A** is your computer, **B** is your V300 and **C** is your modem or router.

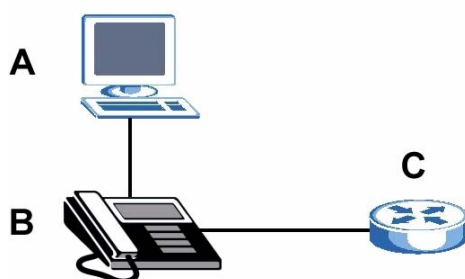

At the time of writing, this User's Guide covers the following models.

Table 1 Models Covered

V300	IP phone.
V301	IP phone with Power over Ethernet (PoE) capability.

1.2 Applications

Here are some examples of how you can use your V300.

1.2.1 Make Calls via Internet Telephony Service Provider

In a home or small office environment, you can use the V300 to make and receive VoIP telephone calls through an Internet Telephony Service Provider (ITSP).

The following figure shows a basic example of how you make a VoIP call through an ITSP. In this example, you make a call from your V300 (**A** in the figure), which sends the call through your modem or router (**B**) to the Internet and the ITSP's SIP server (**C**). The VoIP call server forwards calls to PSTN (Public Switched Telephone Network) phones through a trunking gateway (**D**) to phones on the PSTN network (**E**). The VoIP call server also forwards calls to IP phones (**F**) through the Internet.

Figure 1 Internet Telephony Service Provider Application

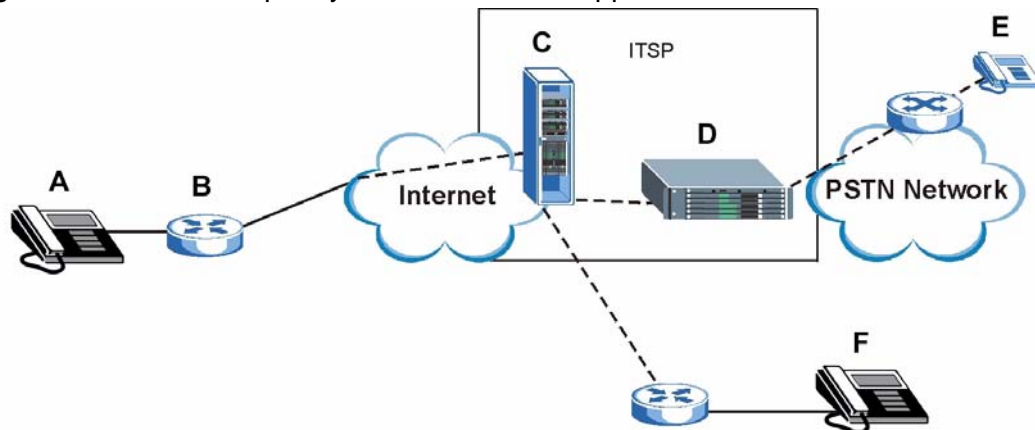

1.2.2 Make Calls via IP-PBX

If your company has an IP-PBX (Internet Protocol Private Branch Exchange), you can use the V300 to make and receive VoIP telephone calls through it.

In this example, you make a call from your V300 (**A** in the figure), which sends it to the IP-PBX. The IP-PBX forwards calls to PSTN phones (**B**) on the PSTN

network. The IP-PBX also forwards calls to IP phones (C) through an IP network (this could include the Internet).

Figure 2 IP-PBX Application

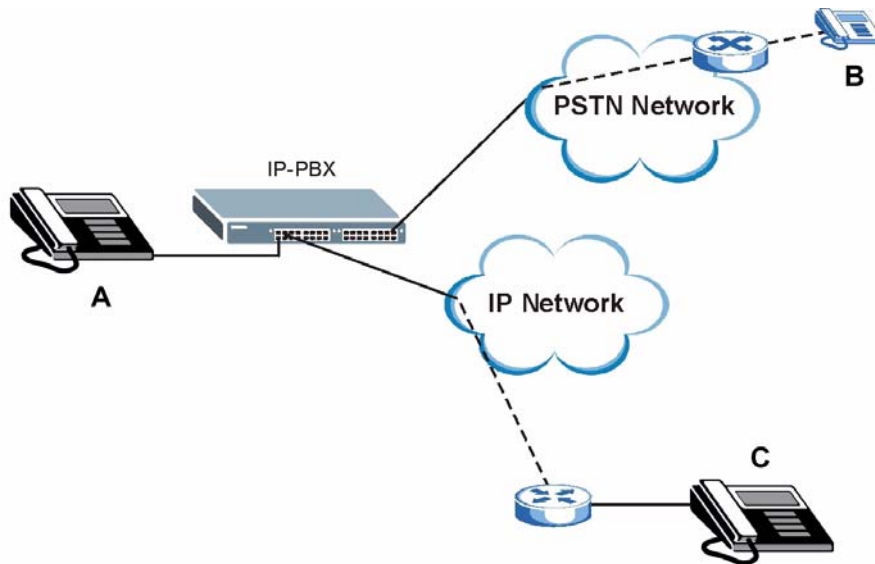

1.2.3 Make Peer-to-peer Calls

Use the V300 to make a call to the recipient's IP address without using a SIP server. Peer-to-peer calls are also called "Point to Point" or "IP-to-IP" calls. You must know the peer's IP address in order to do this.

The following figure shows a basic example of how you would make a peer-to-peer VoIP call. You make a call on your V300 (A), which sends your call through your modem or router (B) and the Internet to the peer VoIP device (C).

Figure 3 Peer-to-peer Calling

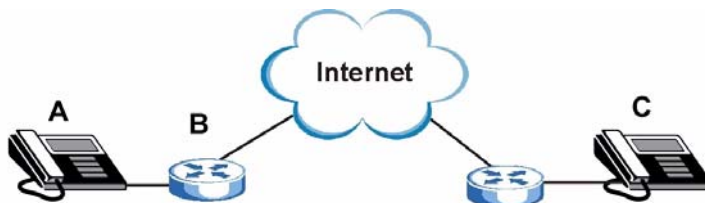

1.3 Ways to Manage the V300

Use any of the following methods to manage the V300.

- Hardware keys. Use the control keys and LCD menus on the V300 for basic configuration.

- Web Configurator. This is recommended for everyday management of the V300 using a (supported) web browser.
- FTP. Use File Transfer Protocol for firmware upgrades and configuration backup/restore.
- SPTGEN. SPTGEN is a text configuration file that you can edit and upload to the device. This is especially convenient if you need to configure many devices of the same type.

1.4 Good Habits for Managing the V300

Do the following things regularly to make the V300 more secure and to manage the V300 more effectively.

- Change the web configurator password. Use a password that's not easy to guess and that consists of different types of characters, such as numbers and letters.
- Write down the password and put it in a safe place.
- Keep the V300 in a safe place. The LCD menus are not password-protected, so anyone using the phone can access your phonebook, SIP account information, etc.
- Back up the configuration (and make sure you know how to restore it). Restoring an earlier working configuration may be useful if the device becomes unstable or even crashes. If you forget your password, you will have to reset the V300 to its factory default settings to access the web configurator. If you backed up an earlier configuration file, you would not have to totally re-configure the V300. You could simply restore your last configuration.

Hardware

2.1 Overview

This chapter describes the V300's physical features, and how to use the phone functions.

2.2 Physical Features

This section discusses the V300's front, side, rear and base panel hardware features. See your Quick Start Guide for descriptions of how to set up the V300's hardware and network connections.

Figure 4 Front Panel Hardware

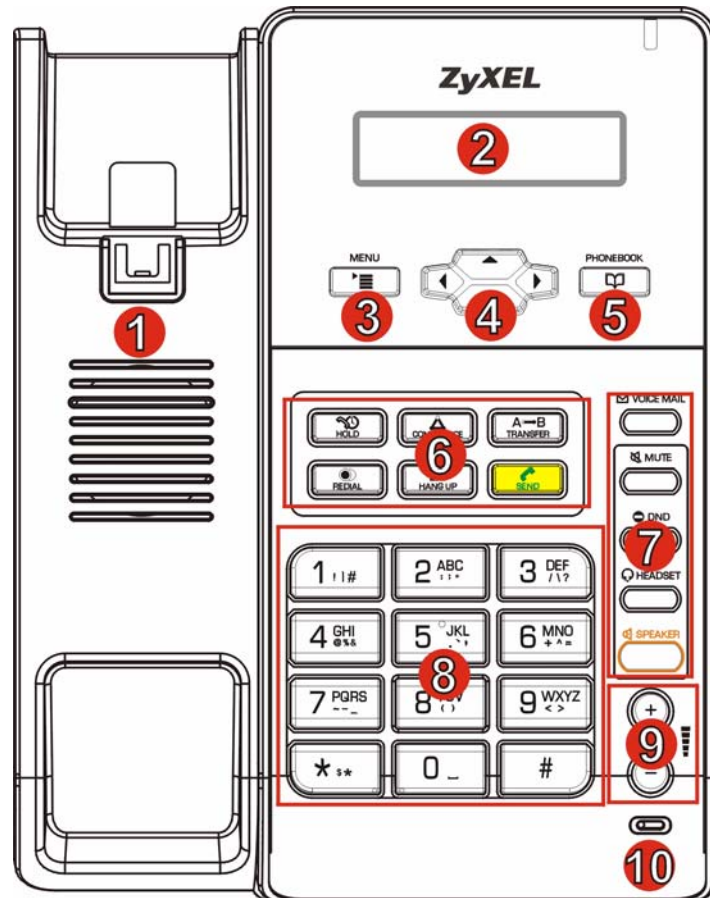

The following table describes the front panel hardware.

Table 2 Front Panel Hardware









LABEL	DESCRIPTION		
1	Handset cradle		
2	LCD (Liquid Crystal Display) screen.		
3	Menu 	Press this to display the V300's configuration menu. When the menu displays, you can press this key again to exit the menu. The menu is not accessible when a call is in progress.	
4	Navigator 	Use this to move around the V300's screens. Press ▲ to go up one line in a menu, and press ▼ to go down one line. In the configuration menu, press ► to enter a menu or continue to the next menu, and press ◀ to go back to the previous menu. When the V300 is not in the configuration menu, you can press ▲ or ▼ to view the previous calls and use ► to delete the records or save them as the contacts in your phone book. When the V300 is connected to the Internet and not in the configuration menu, use ► or ◀ to select the SIP account you want to use to make calls.	
5	Phonebook 	Use this to display the list of contacts stored in the V300. If there is no contact stored in the V300, the message "Phonebook is empty" displays. To add, edit or remove an entry in the phonebook, use the web configurator. See Chapter 12 on page 127 for more information. In a menu, use this to clear the previous settings.	
6	Action keys	HOLD 	Use this to put a call on hold. Press it a second time to take the call off hold.
		CONFERENCE 	Use this to set up a conference call between the V300 and two other phones, or to split a conference call you set up into two separate calls.
		TRANSFER 	Use this to transfer a call to another phone.
		HANG UP 	Use this to end a call.
		REDIAL 	Use this to dial the last number that was called from the V300.
		SEND 	Use this to start a call, once you have entered the phone number.

Table 2 Front Panel Hardware (continued)















LABEL	DESCRIPTION											
7	Function keys	<p>The LEDs (lights) in these keys illuminate when they are active.</p> <table border="1" data-bbox="646 310 1427 993"> <tr> <td data-bbox="646 310 867 415"> VOICEMAIL  </td> <td data-bbox="867 310 1427 415">Use this to check your voicemail messages, once the voicemail number is configured in the V300.</td> </tr> <tr> <td data-bbox="646 415 867 520"> MUTE  </td> <td data-bbox="867 415 1427 520">Use this to mute the current call. The V300 no longer transmits a signal, but you can still hear the incoming signal.</td> </tr> <tr> <td data-bbox="646 520 867 625"> DND  </td> <td data-bbox="867 520 1427 625">Use this to toggle the Do Not Disturb function on or off.</td> </tr> <tr> <td data-bbox="646 625 867 783"> HEADSET  </td> <td data-bbox="867 625 1427 783"> Use this to activate a line using the headset, or to transfer a call to the headset when using the handset or the speakerphone. When a line is active and you are using the headset, press this key to hang up. </td> </tr> <tr> <td data-bbox="646 783 867 993"> SPEAKER  </td> <td data-bbox="867 783 1427 993"> Use this to activate a line using the speakerphone, or to transfer a call to the speakerphone when using the handset or the headset. When a line is active and you are using the speakerphone, press this key to hang up. </td> </tr> </table>	VOICEMAIL 	Use this to check your voicemail messages, once the voicemail number is configured in the V300.	MUTE 	Use this to mute the current call. The V300 no longer transmits a signal, but you can still hear the incoming signal.	DND 	Use this to toggle the Do Not Disturb function on or off.	HEADSET 	Use this to activate a line using the headset, or to transfer a call to the headset when using the handset or the speakerphone. When a line is active and you are using the headset, press this key to hang up.	SPEAKER 	Use this to activate a line using the speakerphone, or to transfer a call to the speakerphone when using the handset or the headset. When a line is active and you are using the speakerphone, press this key to hang up.
VOICEMAIL 	Use this to check your voicemail messages, once the voicemail number is configured in the V300.											
MUTE 	Use this to mute the current call. The V300 no longer transmits a signal, but you can still hear the incoming signal.											
DND 	Use this to toggle the Do Not Disturb function on or off.											
HEADSET 	Use this to activate a line using the headset, or to transfer a call to the headset when using the handset or the speakerphone. When a line is active and you are using the headset, press this key to hang up.											
SPEAKER 	Use this to activate a line using the speakerphone, or to transfer a call to the speakerphone when using the handset or the headset. When a line is active and you are using the speakerphone, press this key to hang up.											
8	Alphanumeric keypad	Use this to enter numbers, letters and symbols. Use the # key to switch between Number mode, Uppercase mode, Lowercase mode and Symbol mode. In the configuration menu, use a numeric key (from 1 to 5) to go to a specific menu directly.										
9	Volume keys	<p>Use the + key to increase the volume, and use the - key to decrease it.</p> <ul data-bbox="657 1213 1427 1381" style="list-style-type: none"> • When you use the handset, these keys control the handset's listening volume. • When you use the headset, these keys control the listening volume on the headphone (📞) port on the V300. • When you use the speakerphone, these keys control the internal speaker volume. 										
10	Microphone	The microphone is active when the V300 is in speakerphone mode.										

Figure 5 Side Panel

The following table describes the side panel hardware.

Table 3 Side Panel Hardware

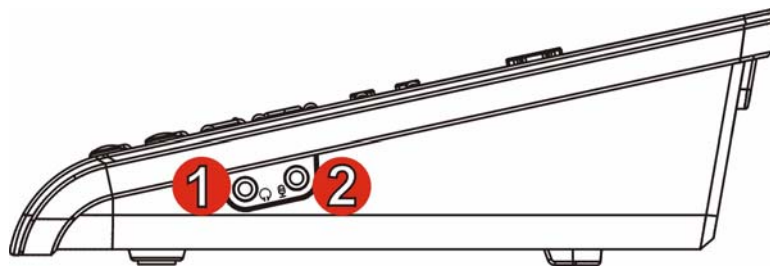

LABEL	DESCRIPTION	
1	Headphone socket 	Use this to connect a headset's earphone jack, headphones, or an external loudspeaker.
2	Microphone socket 	Use this to connect a headset's microphone jack, or an external microphone.

Figure 6 Rear Panel



The following table describes the rear panel hardware.

Table 4 Rear Panel Hardware

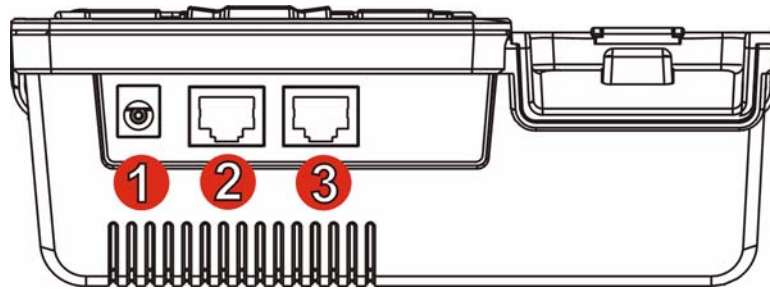
LABEL	DESCRIPTION	
1	Power socket	Attach the included power adaptor, if you are not using Power over Ethernet (V301 only). See the product specifications appendix for power supply specifications. Note: Use only the power adaptor and cable that came with your V300.
2	LAN port	Use an Ethernet cable to connect to your network.
3	PC port	Use an Ethernet cable to connect a computer for configuration, or to access the Internet.

Figure 7 Base Panel Hardware

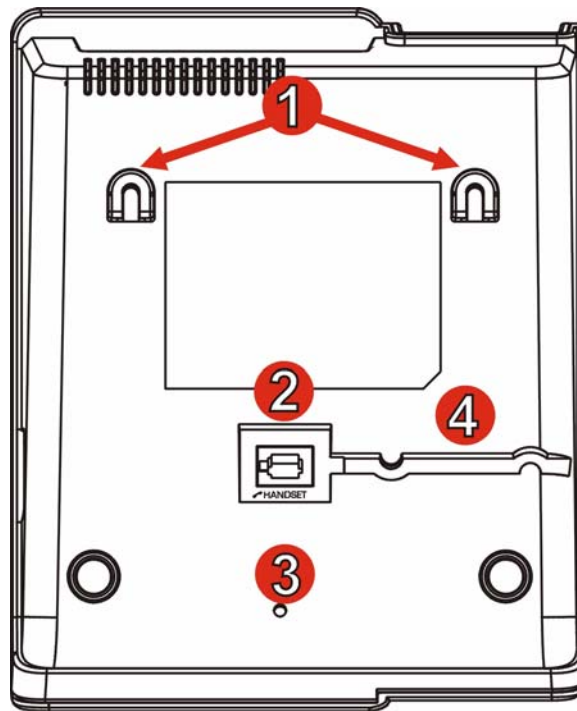

The following table describes the rear panel hardware.

Table 5 Base Panel Hardware

LABEL	DESCRIPTION	
1	Wall-mounting holes	Use these to hang the V300 on a wall. See the wall-mounting appendix for details.
2	Handset port	Use this to attach the included handset cable's RJ-11 connector.

Table 5 Base Panel Hardware

LABEL	DESCRIPTION	
3	Reset button	Use this to return the V300 to its factory default settings. See the appendix on product specifications for the default settings. Note: If you do this, all configuration changes and data on the V300 are lost, including phonebook records.
4	Cable channel	Clip the V300's handset cable into this.

2.2.1 The LCD Screen

When the V300 is on, the LCD (Liquid Crystal Display) screen shows either the status screen, a phonebook screen, or a configuration menu.

The LCD menus allow you to configure and control the V300. See [Chapter 3 on page 45](#) for details on configuring the V300 via the LCD menus.

2.2.2 Resetting the V300

If you want to reset the V300 to its factory defaults (if you forgot the web configurator password, for example) press and hold the **RESET** button for approximately ten seconds. The V300 restarts automatically.

Note: If you reset the V300, all settings return to their factory defaults. All data stored in the V300 (phonebook entries, for example) will be lost.

2.3 Phone Functions

This section describes how to use your V300's basic telephone functions. See [Chapter 3 on page 45](#) for information on the using the V300's LCD screen menus and [Chapter 4 on page 51](#) for information on how to use the V300's phonebook.

2.3.1 Making a Call

- 1 Start the call:
 - If you want to use the handset:
Lift the handset.
 - If you want to use the speakerphone:
Press the **SPEAKER** key.

- If you want to use a headset:

Press the **HEADSET** key.

- 2 Check that you can hear a dial tone.
- 3 Enter the number you want to call. If you have numbers stored in the V300's phone book, you can use the navigator to select from the list of entries.
- 4 Press the yellow **SEND** key.

During the call:

- If you are using the headset or the speakerphone, you can switch to the handset by lifting it off the hook.
- If you are using the handset or the speakerphone, you can switch to the headset by pressing the **HEADSET** key.
- If you are using the handset or a headset, you can switch to the V300's speakerphone by pressing the **SPEAKER** key.

Note that the call ends if you are using the speakerphone and press the **SPEAKER** key, or if you are using the headset and press the **HEADSET** key.

2.3.2 Receiving a Call

When the phone rings, do one of the following:

- Pick up the handset to receive the call using the handset.
- Press the **SPEAKER** key to receive the call using the internal speakerphone.
- Press the **HEADSET** key to receive the call using an external headset.

2.3.3 Ending a Call

When you want to end a call, press the **HANG UP** key. Alternatively, do one of the following:

- If you are using the handset, replace it in the cradle.
- If you are using the internal speakerphone, press the **SPEAKER** key.
- If you are using an external headset, press the **HEADSET** key.

2.3.4 Changing the Volume

Use the **VOLUME +** key to increase the volume, and use the **VOLUME -** key to decrease it.

- When there is no line active on the V300, the volume keys control the ringing volume.

- When the handset is off hook, the keys control the handset's speaker volume.
- When the speakerphone is active, the keys control the speaker volume.
- When the headset is active, the keys control the headset's speaker (earpiece) volume.

2.3.5 Muting a Call

When you mute a call on the V300 you can hear the incoming signal (the sound from the other end of the line) but you do not transmit a signal (the person on the other end of the line cannot hear you). It does not matter whether you are using the handset, the internal speakerphone or an external headset.

Press the **MUTE** key once to mute a call. Press it a second time to return to the call.

2.3.6 Placing a Call on Hold

When you place a call on hold, you neither receive nor transmit a signal. If your phone system is configured to use the Music on Hold feature, the person on the other end of the line hears the preconfigured music (or other audio). Otherwise, they hear nothing.

Press the **HOLD** key once to place a call on hold. Press it a second time to return to the call.

2.3.7 Using Voicemail

Once you have configured your SIP account's voicemail number on the V300, you can press the **VOICEMAIL** key to check your messages.

Use the **VoIP > SIP > SIP Settings** screen to set the voicemail account number. See [Section 10.2 on page 109](#) for more information.

2.3.8 Making Conference Calls

Take the following steps to make a three-way conference call.

- 1 Either start a call, or receive a call. Make sure you know which line the call is using.
- 2 Ensure the call is active (you can talk with the other person). Press the **Conference** key. This "marks" the first call you want to mix into the conference call.

- 3 Select another line. You can either receive an incoming call, make another outgoing call, or resume an existing call that you previously put on hold.
- 4 Ensure the call is active and press the **Conference** key again. The three-way conference call begins. All three parties can talk with one another.

Note: Do not press any other keys between step 2 and step 3. If you do, you will have to start again.

Note: You cannot have a conference call and a transferred call ongoing at the same time.

Note: If the person who started the conference call leaves, the remaining parties can continue talking in the same conference.

2.3.9 Transferring a Call

Take the following steps to transfer an ongoing call to another phone number.

- 1 During the ongoing call, press the **Transfer** key.
- 2 The next available line automatically activates. Ensure you can hear a dial tone.
- 3 Dial the number to which you want to transfer the call.
- 4 To transfer the call, either:
 - Wait until you hear the ringing tone, then simply put down the handset, press the **Speaker** key or the **Headset** key (depending on which you are using) to end the call. The call is transferred. This is known as a blind or unsupervised transfer.
 - Wait for the other person to answer, then press transfer key again to end the call. This is known as a consultant or supervised transfer, and allows you to ask the other person whether they want to receive the call or not.

2.3.10 Upgrading the Phone's Firmware

When it is time to upgrade your phone's firmware, your telephone network administrator will configure the IP PBX to which the V300 is connected to automatically check your phone's existing firmware and compare it to the firmware on an official ZyXEL server. If your firmware's version number does not match, the IP PBX will then initiate the upgrade process:

- 1 When the IP PBX is ready to process your phone, it rings you while the phone is on the hook. As soon as you answer, an automated message asks if you want to change your V300's firmware.
- 2 Enter * 9 9 # on the V300's keypad to answer 'Yes'.
Enter # 9 9 # on the V300's keypad to answer 'No'.
- 3 If you entered 'Yes', then the phone begins downloading the new firmware from the IP PBX. The download and install process may take some time, depending on the size of the update and any network congestion.
- 4 When the download and install process completes, the V300 restarts. You may need to log into your account again.

Note: Do not turn off or attempt to use your V300 during a firmware update.

PART II

Technical Reference

Using the LCD Screen

3.1 Overview

This chapter shows you how to use and configure the V300 via the LCD screen menu system.

Note: See the web configurator section of this guide for background information on the V300's features.

3.2 Navigation

Use the following keys to move around the V300's LCD screen menu system.

- The navigator.
Use this to move the cursor up and down (when selecting a menu item) or left and right (when editing a field).
- The alphanumeric keypad.
Enter a menu item's number to jump to that item (single-digit numbers only).
- The **MENU** key.
Use this to access the V300's configuration menu or exit the menu.
- The **PHONEBOOK** key.
Use this to return to view the stored contacts, or delete a character when editing a field.

Note: When there is more than one entry in a menu, one or two arrows display on the right side of the LCD screen. If you can scroll down to see other entries ↓ displays, if you can scroll up to see other entries ↑ displays, and if you can scroll up or down to see other entries ↑↓ displays. These arrows are not shown in this User's Guide.

3.3 Enabling and Disabling Features

Many of the V300's LCD screen menus allow you check a feature's settings and then edit the setting. Take the following steps to check a feature's current setting and then enable or disable the feature. This example uses the DHCP feature.

- 1 Select the feature you want to configure. In this example, press **MENU** to enter the menu system, then select **Adv Setting**. In the **Adv Setting** menu, select **DHCP**.

The following screen displays:

Figure 8 Example: DHCP



- 2 To change the setting to **ON**, press **▶**.

Note: If later you decide you want to use static IP or PPPoE, then you do not need to come into the DHCP menu to disable it; rather, just go into one of those other menus and enable one of them. This automatically turns DHCP off.

3.4 Entering Numbers, Letters and Symbols

When you enter information into the V300 (when setting up a phonebook entry, for example) you may need to enter different kinds of characters. The alphanumeric keypad has four input modes:

- **Number mode**
- **Uppercase mode**
- **Lowercase mode**
- **Symbol mode**

Use the **#** key to cycle between modes.

Note: Not all modes are available in all screens.

When you press a key to enter a character, wait a short time until the cursor moves on to the next space. Press a key multiple times to access the different characters. For example, in **Uppercase mode** press **9** four times to enter "**Z**".

The following table shows the numbers, letters and symbols you can enter.

Table 6 Keypad Characters

		MODE			
		Number	Uppercase	Lowercase	Symbol
KEY	1	1	[NONE]	[NONE]	! #
	2	2	A B C	a b c	: ; "
	3	3	D E F	d e f	/ \ ?
	4	4	G H I	g h i	@ % &
	5	5	J K L	j k l	. ' ,
	6	6	M N O	m n o	+ ^ =
	7	7	P Q R S	p q r s	~ - _
	8	8	T U V	t u v	()
	9	9	W X Y Z	w x y z	< >
	*	.	.	.	\$ *
	0	0	[NONE]	[NONE]	[SPACE]
	#	[CYCLE MODE]			

3.5 LCD Menu Overview

This section shows the LCD menus, and describes what you can do with each.

Press the Navigator up or down to access the V300's LCD menu system.

Table 7 LCD Menu Overview

MENU		DESCRIPTION
Phonebook		Use this menu to view details of your contacts.
Vol Setting [Volume Setting]	Speaker Volume	Use this menu to set the loudness of the internal speaker.
	Phone Volume	Use this menu to set the loudness of the V300's handset.
	Ring Volume	Use this menu to set the loudness of the V300's ringtone.
	Headset Volume	Use this menu to set the loudness of an external headset you plug into the V300.

Table 7 LCD Menu Overview (continued)

MENU		DESCRIPTION
System Info	IP Address	Use this to see the IP address, subnet mask, gateway, and DNS settings currently assigned to the V300.
	Subnet Mask	
	Gateway	
	1st DNS	
	2nd DNS	
	MAC	Use this to see the MAC (Media Access Control Address) of the V300.
F/W Version	Use this to see the version number of the firmware the V300 is currently using.	
Adv Setting [Advanced Setting]	VoIP1	Use this menu to set up the first Voice over Internet (VoIP) account.
	VoIP2	Use this menu to set up the second Voice over Internet (VoIP) account.
	Auto Prov	Use this menu to set the phone to be configured automatically through auto provisioning.
	DHCP	Use this menu to have the V300 get an IP address automatically.
	Static IP	Use this menu to give your V300 an IP address.
	PPPoE	Use this menu to configure your PPPoE username and password, if provided by your Internet Service Provider or network administrator.
	VLAN	Use this menu to configure the V300's voice VLAN ID and priority.
	LCD Contrast	Use this menu to adjust the contrast of the V300's screen.
	Ring Setting	Use this menu to select a ring tone for your V300.
	Flexwork	Use this menu to "carry" your V300 settings with you when you change locations but are still using a compatible V300 phone.
	Clock Alarm	Use this menu to configure the V300's three built-in alarm clocks.
	Time Zone	Use this to choose the time zone of your location.
	Date Format	Use this to select the date format that shows on the LCD.
Reset	Restart Phone	Use this to restart the V300. Using this feature does NOT return the V300 to its factory defaults.
	Reset Default	Use this to return the V300 to its factory defaults.

3.6 The LCD Status Screen

When you first turn on the V300 or make a call, the status screen displays. The status screen is divided into two main sections, as shown below.

Figure 9 LCD Status Screen



In the status screen, the upper line displays the time and date configured on the V300, and the lower line displays information about the SIP account. The SIP account's name displays if it is successfully registered. If it has tried to register but failed, **NoReg** displays. If the SIP account is not enabled (see [Section 6.3.1 on page 61](#)) **NoUse** displays.

When the phone is in Flexworker mode (see [Section 6.11 on page 78](#) for more), a small 'F' icon on the right side.

Figure 10 Flexworker Icon



The Phonebook

4.1 Overview

Use the V300's phonebook to view or store the names and phone numbers of your contacts.

The following sections describe how to add and use phonebook entries.

Note: The V300 can hold a maximum of 200 private phone numbers and 200 public phone numbers. Public phone numbers are provided by the PBX to which your phone is connected, while private numbers are the ones you enter into your phone memory yourself.

4.1.1 What You Can Do in This Chapter

- Add a call record to your phonebook ([Section 4.2 on page 51](#)).
- Call a previously saved entry in your phonebook ([Section 4.3 on page 52](#)).
- Call a number that is not in your phonebook ([Section 4.4 on page 52](#)).

4.2 Add a Phonebook Entry

Take the following steps to add a call record to the V300's phonebook.

- 1 Press the Navigator up or down to display the previous called numbers.

Figure 11 LCD Contact Record

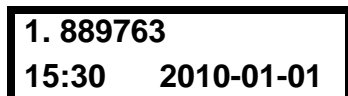

- 2 Press **▶**, select **Save to Phone** and press **▶** again to store this record as a contact entry in your phone book

Figure 12 LCD Contact Record: Save



Note: You can view the stored contact entry by pressing the **PHONEBOOK** key.

4.3 Call a Phonebook Contact

In order to call a number you previously entered into the V300's phonebook, first activate a line (lift the handset, or press the **SPEAKER** or **HEADSET** key). The following screen displays. Ensure you can hear a dial tone.

Figure 13 LCD Dial Screen



Press the **PHONEBOOK** key. The **Contact List** screen displays.

Figure 14 LCD Contact List Screen



Scroll to the contact name or number you want to call, then press the **SEND** key to dial the number.

Note: The numbers that display to the left of a contact's name in this screen are index numbers only - you cannot use them to select an entry to call.

4.4 Calling a Number Not in the Phonebook

When you want to call a number that is not in your V300's phonebook, activate a line, dial the number and press the **SEND** key to start the call.

LCD Menu: Basic Settings

5.1 Overview

This chapter discusses how to set up your V300 using the internal configuration menus.

5.1.1 What You Can Do in This Chapter

- The **Menu** system lets you configure your V300 ([Section 5.2 on page 53](#)).
- The **Phonebook** menu lets you view a list of your contacts ([Section 5.3 on page 54](#)).
- The **Volume** menu lets you set the loudness of the speakers ([Section 5.4 on page 54](#)).
- The **Advanced Setting** menu let you configure a range of more detailed phone options, such as your VoIP account and PPPoE settings ([Section 5.6 on page 56](#)).
- The **Reset** menu lets you restart the phone or restore its defaults ([Section 5.7 on page 56](#)).

5.2 Entering the Menu System

Press **MENU** to enter the menu system. The **Menu Setting** screen displays as shown below.

Figure 15 LCD Menu Setting



See the rest of this chapter for details on configuring each menu. For background information, see the relevant chapter in the web configurator section of this User's Guide.

Note: When a menu has more than one option, only the first option can be seen on the LCD screen. Use the navigator to scroll down to the other options.

5.3 The Phonebook Menu

Use the phonebook to view a list of your contacts.

Select **MENU > Phonebook**. The following screen displays. This is the same function as pressing the actual **PHONEBOOK** button.

Figure 16 LCD Menu: Phonebook



If you want to add, edit or remove an entry in the phonebook, use the web configurator. See [Chapter 7 on page 83](#) for more information.

If you want to add a call record in the phonebook or call a phonebook contact, see [Chapter 4 on page 51](#).

5.4 The Volume Setting Menu

Use these menus to set the loudness of the V300's audio equipment.

Select **MENU > Vol Setting**. The following screen displays.

Figure 17 LCD Menu: Volume Setting



The following table describes the labels in this screen.

Table 8 LCD Menu: Volume Setting

LABEL	DESCRIPTION
Speaker Volume	Select this to set the internal speakerphone volume. This controls both the internal speaker and the internal microphone.
Phone Volume	Select this to set the handset volume. This controls both the handset's speaker and its microphone.
Ring Volume	Select this to set the volume of the V300's ringtone. This setting applies to all configured group rings.
Headset Volume	Select this to set the volume of an attached headset (or any device connected to the external speaker and/or microphone sockets). This controls both the handset's speaker (earpiece) and its microphone.

5.4.1 Volume Screen

When you select one of the options in the **Volume Setting** menu, a screen similar to the following displays. This example uses the **Speaker Volume** screen.

Figure 18 LCD Menu: Volume Screen



Use the **VOLUME** keys to increase or decrease the volume. Press ◀ or ▶ to go back to the previous menu when you are done.

5.5 The System Info Menu

The System Info menu allows you to quickly check some of your V300's settings. These settings are read-only.

Select **MENU > System Info**. The following screen displays.

Press ▶ to enter the **System Info** menu and use the arrows to view the system settings.

Figure 19 LCD Menu: System Info



The following table describes the labels in this menu.

Table 9 LCD Menu: System Info

LABEL	DESCRIPTION
IP Address	This is the IP address currently assigned to the V300. This displays 0.0.0.0 if DHCP is disabled.
Subnet Mask	This is the subnet mask currently configured on the V300. This displays 0.0.0.0 if DHCP is disabled.
Gateway	This is the IP address of the device on the network your V300 uses to access the Internet. This displays 0.0.0.0 if DHCP is disabled.
1st DNS	This is the primary DNS (Domain Name System) server your V300 uses. This displays 0.0.0.0 if DHCP is disabled.
2nd DNS	This is the secondary (backup) DNS server your V300 uses. This displays 0.0.0.0 if DHCP is disabled.
F/w Version	This is the version number of the firmware currently running on the V300. You can upload new firmware using the web configurator.

5.6 The Advanced Setting Menu

Use this menu to configure network and SIP account settings. See [Chapter 6 on page 59](#) for information on the **Advanced Setting** menu.

5.7 The Reset Menu

Use this menu to restart the V300 or reset the V300 to the factory defaults. Press **MENU > Reset** and then **▶** to access the **Reset** menu. The following screen displays.

Figure 20 LCD Menu: Reset



5.7.1 System Restart

Use this screen to restart the V300 without turning the power off.

- 1 Select **RestartPhone**.

Figure 21 LCD Menu: Reset: System Restart



- 2 Press **▶** and the following screen displays. Press the **1** key to restart the V300 or press the **2** key to return to the previous menu without restarting the V300.

Figure 22 LCD Menu: Reset: System Restart: Confirm



5.7.2 Load Factory Default

Use this screen to reset the V300 back to the factory defaults.

- 1 Select **ResetDefault**.

Figure 23 LCD Menu: Reset: Reset Default



- 2 Press **▶** and the following screen displays. Press the **1** key to clear all user-entered information and return to the factory defaults. Otherwise, press the **2** key to go back to the previous menu without resetting the V300.

Figure 24 LCD Menu: Reset: Reset Default: Confirm

<p>Yes ->Press 1 No ->Press 2</p>

LCD Menus: Advanced

6.1 Overview

This chapter shows you how to use the V300's LCD menus.

6.1.1 What You Can Do in This Chapter

- The **VoIP** menu let you set up your voice accounts ([Section 6.3 on page 60](#)).
- The **Auto Provision** menu lets you set up the V300 to receive its configuration data automatically from the SIP server to which it is registered ([Section 6.4 on page 67](#)).
- The **DHCP** menu lets you have the V300 get an IP address automatically from a DHCP server on the network ([Section 6.5 on page 71](#)).
- The **Static IP** menu lets you manually configure your V300's IP address, subnet mask and gateway settings ([Section 6.6 on page 71](#)).
- The **PPPoE** menu lets you configure your V300's PPPoE username and password, if it is a PPPoE client ([Section 6.7 on page 74](#)).
- The **VLAN** menu lets you enable VLAN and configure the V300's voice VLAN ID and priority ([Section 6.8 on page 76](#)).
- The **LCD Contrast** screen lets you adjust the contrast setting on the V300's LCD ([Section 6.9 on page 77](#)).
- The **Ring Setting** screen lets you choose a ring tone ([Section 6.10 on page 78](#)).
- The **Flexworker** screen allows you to "carry" your V300 settings with you when you change locations ([Section 6.11 on page 78](#)).
- The **Clock Alarm** screen allows you to view the V300's three internal clock alarm configurations ([Section 6.12 on page 80](#)).
- The **Time Zone** screen lets you choose the time zone of your location ([Section 6.13 on page 80](#)).
- The **Date Format** screen lets you select the date format that shows on the V300's LCD screen ([Section 6.14 on page 80](#)).

6.1.2 What You Need to Know

The following terms and concepts may help you as you read through this chapter.

HTTP

HyperText Transfer Protocol is commonly used on the Internet. HTTP is the primary protocol used for web sites and web browsers. It is also prone to certain kinds of attacks.

HTTPS

HyperText Transfer Protocol over Secure Socket Layer, or HTTP over SSL is a web protocol that encrypts and decrypts web pages. Secure Socket Layer (SSL) is an application-level protocol that enables secure transactions of data by ensuring confidentiality (an unauthorized party cannot read the transferred data), authentication (one party can identify the other party) and data integrity (you know if data has been changed).

TFTP

Trivial File Transfer Protocol (TFTP) is an Internet file transfer protocol similar to FTP (File Transfer Protocol), but is scaled back in functionality to require fewer resources to run. TFTP uses the UDP (User Datagram Protocol) rather than TCP (Transmission Control Protocol).

6.2 The Advanced Setting Menu

Press **MENU** to access the LCD screen menu system, select **Adv Setting** and press **▶**. The following screen displays.

Figure 25 LCD Menu: Advanced Setting

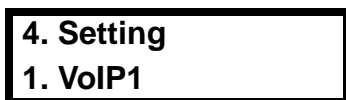

6.3 The VoIP Menus

Use these menus to set up your V300 to set up and use a Voice over Internet (VoIP) account.

Note: Once you have configured the fields in these menus with the correct information, the V300 must register with the SIP server. You may need to restart the V300 to do this.

Note: Enter information in these menus exactly as you received it from your VoIP service provider. If you were not given information for any menu or field, leave it at its default setting.

Select **Adv Setting > VoIP1** or **VoIP2** and press **▶**, upon which you are prompted to enter the V300's admin password (the default is '1234'). If you make a mistake, press the PHONEBOOK to delete your entry one number at a time.

Figure 26 LCD Menu: Admin Password Entry

Password:

Press **▶** once again after entering the password. If correct, the following screen displays.

Figure 27 LCD Menu: SIP Active

1. SIP1/2 Active On

See the following sections for more information on each menu in this screen.

Table 10 LCD Menu: SIP Account Configuration

SIP Active	see Section 6.3.1 on page 61
SIP Num	see Section 6.3.2 on page 62
Serv Addr	see Section 6.3.3 on page 63
Serv Port	see Section 6.3.4 on page 63
Reg Addr	see Section 6.3.5 on page 64
Reg Port	see Section 6.3.6 on page 65
Domain	see Section 6.3.7 on page 65
User ID	see Section 6.3.8 on page 66
Password	see Section 6.3.9 on page 67

6.3.1 SIP Active

Use this screen to set whether the SIP account linked is active or not. When the account is inactive, you cannot make or receive calls on the V300 using that account. You can, however, use the other account, assuming it is active. If both are inactive, then the V300 cannot make or receive any phone calls whatsoever.

Select **Adv Setting > VoIP1** or **VoIP2 > SIP Active** and enter the password when prompted. The following screen displays.

Figure 28 LCD Menu: SIP Active



Press **▶** to toggle between the **ON** and **OFF** settings.

6.3.2 SIP Number

Use this to see and edit the SIP number for your SIP account.

Note: If you have a SIP account like "1234567@voip-provider.com", the SIP Number is "1234567".

Select **Adv Setting > VoIP1** or **VoIP2 > SIP1 Num.** The following screen displays.

Figure 29 LCD Menu: SIP Number

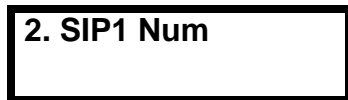

If a SIP account number is already configured, it displays. Otherwise, no SIP number displays. Press **▶** to edit the SIP number, or press **◀** to return to the previous screen.

6.3.2.1 SIP Number - Edit

Press **▶** in the **SIP Num** screen. The following screen displays.

Figure 30 LCD Menu: SIP Number - Edit



Use **PHONEBOOK** to clear the previously-saved settings if any. Enter the new SIP account number and press **▶** to save the change. Alternatively, press **◀** to return to the previous screen.

6.3.3 SIP Server Address

Use this menu to see and edit the IP address of the SIP server for your account. Select **Adv Setting > VoIP1** or **VoIP2 > Serv Addr**. The following screen displays.

Figure 31 LCD Menu: SIP Server Address



The IP address of the SIP server already configured on the V300 displays. If no IP address is already configured, none displays. Press **▶** to edit the SIP server address, or press **◀** to return to the previous screen.

6.3.3.1 SIP Server Address - Edit

Press **▶** in the **Serv Addr** screen. The following screen displays.

Figure 32 LCD Menu: SIP Server Address - Edit



Use **PHONEBOOK** to clear the previously-saved settings if any. Enter the new SIP server address and press **▶** to save the change. Alternatively, press **◀** to return to the previous screen.

6.3.4 SIP Server Port

Use this screen to see and edit the port on the this account's SIP server used for SIP calls. Select **Adv Setting > VoIP1** or **VoIP2 > Serv Port**. The following screen displays.

Figure 33 LCD Menu: SIP Server Port



This screen displays the SIP server port number on the V300. The default is 5060. Press **▶** to edit the SIP server port number, or press **◀** to return to the previous screen.

Note: Make no changes in this screen unless your service provider told you to.

6.3.4.1 SIP Server Port - Edit

Press **▶** in the **Serv Port** screen. The following screen displays.

Figure 34 LCD Menu: SIP Server Port - Edit



Use **PHONEBOOK** to clear the previously-saved settings if any. Enter the new SIP server port number (from 1024 to 65535) and press **▶** to save the change. Alternatively, press **◀** to return to the previous screen.

Note: The port number can consist of numerals (0 ~ 9) only.

6.3.5 SIP Register Server

Use this menu to see and edit the IP address of the server your SIP service provider uses to register the V300. Select **Adv Setting > VoIP1** or **VoIP2 > Reg Addr**. The following screen displays.

Figure 35 LCD Menu: SIP Register Server



The IP address of the SIP register server already configured on the V300 displays. If no IP address is already configured, none displays. Press **▶** to edit the SIP register server address, or press **◀** to return to the previous screen.

6.3.5.1 SIP Register Server - Edit

Press **▶** in the **Reg Addr** screen. The following screen displays.

Figure 36 LCD Menu: SIP Register Server Address - Edit



Use **PHONEBOOK** to clear the previously-saved settings if any. Enter the new SIP register server address and press **▶** to save the change. Alternatively, press **◀** to return to the previous screen.

6.3.6 SIP Register Port

Use this screen to see and edit the listening port on the SIP register server for calls from this account. Select **Adv Setting > VoIP1** or **VoIP2 > Reg Port**. The following screen displays.

Figure 37 LCD Menu: SIP Register Port



This screen displays the SIP register server port number on the V300. The default is 5060. Press **▶** to edit the SIP register server port number, or press **◀** to return to the previous screen.

Note: Make no changes in this screen unless your service provider told you to.

6.3.6.1 SIP Register Port - Edit

Press **▶** in the **Reg Port** screen. The following screen displays.

Figure 38 LCD Menu: SIP Register Port - Edit



Use **PHONEBOOK** to clear the previously-saved settings if any. Enter the new SIP server port number (from 1024 to 65535) and press **▶** to save the change. Alternatively, press **◀** to return to the previous screen.

Note: The port number can consist of numerals (0 ~ 9) only.

6.3.7 SIP Service Domain

Use this to see and edit the SIP service domain configured for your SIP account. The SIP service domain of the VoIP service provider (the company that lets you make phonecalls over the Internet) is the domain name in a SIP URI. For example, if the SIP address is "1122334455@voip-provider.com", then "voip-provider.com" is the SIP service domain.

Select **Adv Setting > VoIP1** or **VoIP2 > Domain**. The following screen displays.

Figure 39 LCD Menu: SIP Service Domain



If a SIP domain is already configured on the V300, it displays in this screen. If no SIP domain is already configured, none displays. Press **▶** to edit the SIP domain, or press **◀** to return to the previous screen.

6.3.7.1 SIP Service Domain - Edit

Press **▶** in the **Domain** screen. The following screen displays.

Figure 40 LCD Menu: SIP Service Domain - Edit



Use **PHONEBOOK** to clear the previously-saved settings if any. Enter the new SIP service domain. If you have a SIP account like "1234567@voip-provider.com", the SIP service domain is "voip-provider.com". Press **▶** to save the change. Alternatively, press **◀** to return to the previous screen.

6.3.8 SIP User ID

A SIP account's user ID is its username. Select **Adv Setting > VoIP1** or **VoIP2 > User ID** to see and edit the SIP user name for your SIP account. The following screen displays.

Figure 41 LCD Menu: SIP User ID



If a SIP authentication ID is already configured on the V300, it displays in this screen. If no SIP authentication ID is already configured, none displays. Press **▶** to edit the SIP authentication ID, or press **◀** to return to the previous screen.

6.3.8.1 SIP Authentication ID - Edit

Press **▶** in the **User ID** screen. The following screen displays.

Figure 42 LCD Menu: SIP User ID - Edit



Use **PHONEBOOK** to clear the previously-saved settings if any. Enter the new SIP authentication ID. Press **▶** to save the change. Alternatively, press **◀** to return to the previous screen.

6.3.9 SIP Password

Use this screen to see and edit the password for your SIP account. Select **Adv Setting > VoIP1** or **VoIP2 > Password**. The following screen displays.

Figure 43 LCD Menu: Authentication Password



If a SIP authentication password is already configured on the V300, it displays in this screen as a row of asterisks (*). If no SIP authentication password is already configured, no asterisks display. Each asterisk represents one character of the password configured on the V300. Press **▶** to edit the SIP authentication password, or press **◀** to return to the previous screen.

6.3.9.1 Authentication Password - Edit

Press **▶** in the **Password** screen. The following screen displays.

Figure 44 LCD Menu: Authentication Password - Edit



Use **PHONEBOOK** to clear the previously-saved settings if any. Enter the new SIP authentication password. Press **▶** to save the change. Alternatively, press **◀** to return to the previous screen.

6.4 The Auto Provision Menu

The auto provision menu lets you set up the V300 to receive its configuration data automatically from the SIP server to which it is registered.

Select **Adv Setting > Auto Prov** and press **▶**, upon which you are prompted to enter the V300's admin password (the default is '1234'). If you make a mistake, press the **PHONEBOOK** key to delete your entry one number at a time.

Figure 45 LCD Menu: Admin Password Entry



Press **▶** once again after entering the password. If correct, the following screen displays.

Figure 46 LCD Menu: DHCP



See the following sections for more information on each menu in this screen.

Table 11 LCD Menu: SIP Account Configuration

Active	see Section 6.4.1 on page 68
Protocol	see Section 6.4.2 on page 68
Serv Addr	see Section 6.4.3 on page 69
Serv Port	see Section 6.4.4 on page 70
Expire Time	see Section 6.4.5 on page 70
Retry Time	see Section 6.4.6 on page 70

6.4.1 Auto Provision Active

When the auto provision feature is set to **ON**, the V300 then receives all the information it needs to be immediately usable from the SIP server to which it is registered. This is a zero-configuration option that automatically determines the phone's extension number, IP address, and other relevant network data. However, before this feature can be fully utilized the SIP server must be configured in advance to provide the settings needed by the V300.

Select **Adv Setting > Auto Prov > Active** and enter the password when prompted. The following screen displays.

Figure 47 LCD Menu: DHCP



Press **▶** to toggle auto provisioning **OFF** and **ON**.

6.4.2 Protocol

Select **Adv Setting > Auto Prov > Protocol**. The following screen displays.

Figure 48 LCD Menu: Protocol



Press **▶** to toggle auto provisioning **HTTP**, **HTTPS**, and **TFTP**.

The following table describes the labels in this screen.

Table 12 LCD Menu: Static IP

LABEL	DESCRIPTION
HTTP	Select this option if the SIP server to which your V300 is registered uses HTTP as its auto provisioning protocol.
HTTPS	Select this option if the SIP server to which your V300 is registered uses HTTPS as its auto provisioning protocol.
TFTP	Select this option if the SIP server to which your V300 is registered uses TFTP as its auto provisioning protocol.

6.4.3 Auto Provisioning Server Address

Select **Adv > Auto Prov > Serv Addr**. The following screen displays.

Figure 49 LCD Menu: Serv Addr



Press **▶** to configure the auto provisioning server's IP address.

If you make a mistake, use the PHONEBOOK key to delete your entry one number at a time (you can use the asterix key [*] to enter periods). Press **▶** again to save the address.

If the IP address that you entered is malformed or contains mistakes, then the following error message displays.

Figure 50 LCD Menu: Serv Addr Error



Otherwise, the IP address that you entered is locked into the phone until manually edited again later. You can edit or delete the IP address by entering this screen and using the PHONEBOOK key to clear entries.

6.4.4 Server Port

Select **Adv > Auto Prov > Serv Port**. The following screen displays.

Figure 51 LCD Menu: Serv Port



The default is '8080'. Press **▶** to change this.

If you make a mistake, use the PHONEBOOK key to delete your entry one number at a time (you can use the asterix key [*] to enter periods). Press **▶** again to save the port number.

6.4.5 Expire Time

Select **Adv > Auto Prov > Expire Time**. The following screen displays.

Figure 52 LCD Menu: Expire Time



The default is '3600' seconds, or 60 minutes. Press **▶** to change this. The maximum allowed is 259200 seconds, or 72 hours/3 days.

If you make a mistake, use the PHONEBOOK key to delete your entry one number at a time. Press **▶** again to save the expire time.

6.4.6 Retry Time

Select **Adv > Auto Prov > Retry Time**. The following screen displays.

Figure 53 LCD Menu: Retry Time



The default and maximum is '1800' seconds, or 30 minutes. Press **▶** to change this. The minimum allowed is 1 second.

If you make a mistake, use the PHONEBOOK key to delete your entry one number at a time. Press **▶** again to save the retry time.

6.5 DHCP

Use DHCP to have the V300 get an IP address automatically from a DHCP server on the network.

Select **Adv Setting** > **DHCP**. The following screen displays.

Figure 54 LCD Menu: DHCP



Check whether DHCP is enabled on the V300 or not.

If DHCP is disabled (**Off**), press **▶** to enter the **DHCP** screen and press **▶** again to change the configuration (turn DHCP on). Alternatively press **◀** to return to the previous screen.

Note: If static IP or PPPoE is enabled, DHCP will be disabled automatically.

6.6 The Static IP Menu

Use this menu to manually configure your V300's IP address, subnet mask and gateway settings. Enter the settings exactly as your ISP or network administrator gave them to you.

Select **Adv Setting** > **Static IP**. The following screen displays.

Figure 55 LCD Menu: Static IP



Press **▶** to toggle static IP **OFF** and **ON**.

The following table describes the other labels in this section.

Table 13 LCD Menu: Static IP

LABEL	DESCRIPTION
Static IP	Select this to turn on static IP. Your V300 uses the IP settings you configure in this menu. If DHCP or PPPoE is enabled, static IP will be disabled automatically.
IP Address	Select this to set the static IP address you want the V300 to use.
Gateway	Select this to set the IP address of the device your V300 uses to access the Internet.

Table 13 LCD Menu: Static IP

LABEL	DESCRIPTION
Subnet Mask	Select this to enter the subnet mask your V300 uses.
1st DNS	Select this to enter the primary DNS (Domain Name System) server's IP address.
2nd DNS	Select this to enter the secondary (backup) DNS server's IP address.

See the following sections for more information on each menu in this screen.

Table 14 LCD Menu: SIP Account Configuration

Static IP	see Section 6.6 on page 71
IP Address	see Section 6.6.1 on page 72
Gateway	see Section 6.6.2 on page 73
Subnet Mask	see Section 6.6.3 on page 73
1st and 2nd DNS Servers	see Section 6.6.4 on page 74

6.6.1 IP Address

Select **Adv Setting > Static IP > IP Address**. The following screen displays.

Figure 56 LCD Menu: IP Address

The number that displays is the static IP address currently configured on the V300. Press **▶** to edit the static IP address, or press **◀** to return to the previous screen.

6.6.1.1 IP Address - Edit

Press **▶** in the **IP Address** screen. The following screen displays.

Figure 57 LCD Menu: IP Address - Edit

Use **PHONEBOOK** to clear the previously-saved settings if any. Enter your static IP address and press **▶** to save the change. Alternatively, press **◀** to return to the previous screen.

6.6.2 Gateway

Select **Adv Setting > Static IP > Gateway**. The following screen displays.

Figure 58 LCD Menu: Gateway



The number that displays is the static IP address of the device your V300 uses to access the Internet. Press **▶** to edit the static IP address, or press **◀** to return to the previous screen.

6.6.2.1 Default Gateway - Edit

Press **▶** in the **Gateway** screen. The following screen displays.

Figure 59 LCD Menu: Gateway - Edit



Use **PHONEBOOK** to clear the previously-saved settings if any. Enter the new gateway IP address and press **▶** to save the change. Alternatively, press **◀** to return to the previous screen.

6.6.3 Subnet Mask

Select **Adv Setting > Static IP > Subnet Mask**. The following screen displays.

Figure 60 LCD Menu: Subnet Mask



The number that displays is the subnet mask your V300 is currently set to use. Press **▶** to edit the subnet mask, or press **◀** to return to the previous screen.

6.6.3.1 Subnet Mask - Edit

Press **▶** in the **Subnet Mask** screen. The following screen displays.

Figure 61 LCD Menu: Subnet Mask - Edit



Use **PHONEBOOK** to clear the previously-saved settings if any. Enter the new subnet mask and press **▶** to save the change. Alternatively, press **◀** to return to the previous screen.

6.6.4 First and Second DNS Servers

Use these screens to enter the IP address(es) of DNS (Domain Name System) servers on your network. Use **1st DNS** for the primary (main) server, and use **2nd DNS** if you have information about a secondary (backup) server.

Select **1st DNS** or **2nd DNS** in the **Advanced Setting > Static IP** menu. A screen similar to the following displays (this example uses the **1st DNS** screen).

Figure 62 LCD Menu: First / Second DNS



5. 1st DNS:
0.0.0.0

If a DNS server is already configured, its IP address displays. Otherwise, no IP address displays. Press **▶** to edit the DNS server settings, or press **◀** to return to the previous screen.

6.6.4.1 First / Second DNS - Edit

Press **▶** in the **1st DNS** or **2nd DNS** screen. A screen similar to the following displays (this example uses the **1st DNS** screen).

Figure 63 LCD Menu: First / Second DNS - Edit



5 1st DNS: 1
0.0.0.0_

Use **PHONEBOOK** to clear the previously-saved settings if any. Enter the new DNS server IP address and press **▶** to save the change. Alternatively, press **◀** to return to the previous screen.

6.7 The PPPoE Menu

Use this menu to configure your V300's PPPoE username and password, if it is a PPPoE client. Enter your details exactly as your ISP or network administrator gave them to you.

Select **Adv Setting** > **PPPoE**. The following screen displays.

Figure 64 LCD Menu: PPPoE



The following table describes the labels in this screen.

Table 15 LCD Menu: PPPoE

LABEL	DESCRIPTION
PPPoE	Use this to turn PPPoE on. If DHCP or static IP is enabled, PPPoE will be disabled automatically.
Username	Enter your PPPoE username.
Password	Enter your PPPoE password.

See the following sections for more information on each menu in this screen.

Table 16 LCD Menu: SIP Account Configuration

PPPoE	see Section 6.7 on page 74
PPPoE Username	see Section 6.7.1 on page 75
PPPoE Password	see Section 6.7.2 on page 76

6.7.1 PPPoE Username

Select **Adv Setting** > **PPPoE** > **Username**. The following screen displays.

Figure 65 LCD Menu: PPPoE Username



Press **▶** to edit the PPPoE username, or press **◀** to return to the previous screen.

6.7.1.1 PPPoE Username - Edit

If you press **▶** in the **Username** screen, the following screen displays.

Figure 66 LCD Menu: PPPoE Username - Edit



Use **PHONEBOOK** to clear the previously-saved settings if any. Enter your PPPoE username and press **▶** to save the change. Alternatively, press **◀** to return to the previous screen.

6.7.2 PPPoE Password

Select **Adv Setting > PPPoE > Password**. The following screen displays.

Figure 67 LCD Menu: PPPoE Password



Press **▶** to edit the PPPoE password, or press **◀** to return to the previous screen.

6.7.2.1 PPPoE Password - Edit

Press **▶** in the **PPPoE > Password** screen. The following screen displays.

Figure 68 LCD Menu: PPPoE Password - Edit



Use **PHONEBOOK** to clear the previously-saved settings if any. Enter your PPPoE username and press **▶** to save the change. Alternatively, press **◀** to return to the previous screen.

6.8 The VLAN Menu

The V300 can be a member of a VLAN group to communicate with the SIP server. You can assign the V300's traffic priority that goes through the VLAN group.

In the following example, the V300, a desktop and a notebook are all in VLAN1 group. This VLAN group can access the Internet through a gateway. The VoIP traffic used by the V300 within VLAN1 has the highest priority, so its VLAN Priority is set to 7. The WAN and WLAN traffic used by the desktop and notebook are set to lower priority.

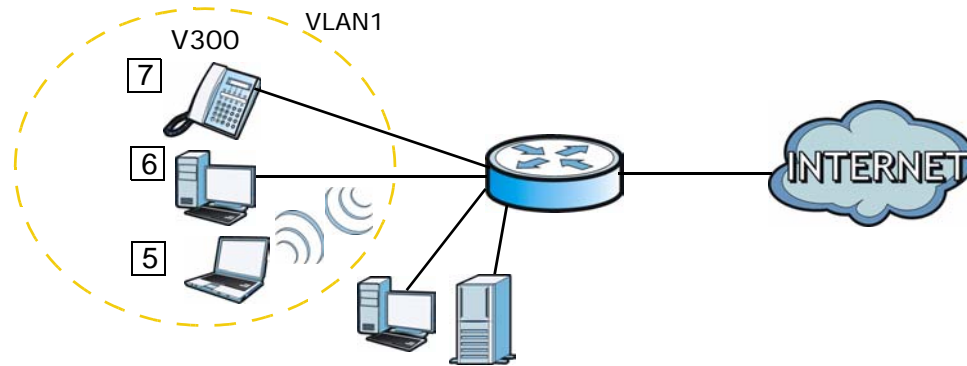

In this menu, enable and configure your V300's voice VLAN ID and priority. Select **Adv Setting > VLAN**. The following screen displays.

Figure 69 LCD Menu: VLAN



Press **▶** to toggle VLAN **OFF** and **ON**.

The following table describes the labels in this screen.

Table 17 LCD Menu: VLAN

LABEL	DESCRIPTION
VLAN	Select this to enable the VLAN. Select this if the V300 has to be a member of a VLAN to communicate with the SIP server. Ask your network administrator if you are unsure.
VLAN ID	Enter the VLAN ID provided by your network administrator. Your LAN and gateway must be configured to use VLAN tags.
VLAN PRIORITY	If the V300 is a member of a VLAN group, you may choose a priority level for its VoIP traffic within the VLAN. The priority level is from 0-7 , with 0 being the lowest level and 7 being the highest level. You can assign the V300 with a higher traffic priority for better voice quality.

6.9 LCD Contrast

Select **Adv Setting > LCD Contrast**. The following screen displays.

Figure 70 LCD Menu: LCD Contrast



Use the **VOLUME** keys to increase or decrease the contrast. Press ◀ or ▶ to go back to the previous menu when you are done.

6.10 Ring Setting

Select **Adv Setting** > **Ring Setting**. The following screen displays.

Figure 71 LCD Menu: Ring Type



Use the ▲ ▼ keys to cycle through the available ring types. Press ◀ or ▶ to go back to the previous menu when you are done.

6.11 Flexworker Mode

Use this menu to turn Flexworker mode on or off.

The Flexworker feature allows you to “carry” your V300 settings with you when you change locations but are still using a compatible V300 phone.

Select **Adv Setting** > **Flexworker**. The following screen displays.

Figure 72 LCD Menu: Flexworker Mode



Use the ▶ key to turn Flexworker mode either **On** or **Off**. Press ◀ to go back to the previous menu when you are done.

6.11.1 Using Flexworker Mode

The Flexworker system lets a person use any V300 connected to an IP PBX that supports auto-provisioning (such as the ZyXEL X6004) and retain its account-specific settings.

All available V300 phones are suitable candidates as long as Flexworker is activated in them. A person can log into any one of them. An unavailable IP phone cannot be chosen as it is one that someone is already logged into it. It can only be used once that person logs out.

To use Flexworker:

- 1 First, choose an available IP phone. If the phone has been configured to use Flexworker and nobody is currently logged on, then the following screen displays:

16:01 2010-01-01
Flexworker Login

- 2 Press the ▲ key to display the **Extension Number** screen, as shown next:

1. Extension Num

Press the ► key to set it to edit mode, then enter your extension number as provided by the phone network administrator.

Press the ► key a second time to save your changes, then ◀ to turn off edit mode.

- 3 Press the ▼ key to display the **User Name** screen, as shown next:

2. User Name

Press the ► key to set it to edit mode, then enter your user name as provided by the phone network administrator.

Press the ► key a second time to save your changes, then ◀ to turn off edit mode.

- 4 Press the ▼ key to display the **Password** screen, as shown next:

3. Password

Press the ► key to set it to edit mode, then enter your password as provided by the phone network administrator.

Press the ► key a second time to save your changes, then ◀ to turn off edit mode.

- 5 Press the ◀ to return to the main menu. The V300 automatically logs in using the information you just configured.

- 6 Once the V300 verifies the login information with the IP PBX, the LED screen updates accordingly and it downloads any other account-specific information.

- 7 Finally, press the ▲ key to log out. The following screen displays:

FLEXWORKER
Logout?

Press the ► key to confirm the logout.

6.12 Clock Alarm

Use this menu to view the V300's three internal clock alarm configurations.

Select **Adv Setting** > **Clock Alarm**. The following screen displays.

Figure 73 LCD Menu: Clock Alarm



Use the ▲ ▼ keys to cycle through the three clock alarms. Press ◀ to go back to the previous menu when you are done.

To configure the clock alarms, you need to log into the Web Configurator. See [Chapter 13 on page 144](#) for more information.

6.13 Time Zone

Use this menu to choose the V300's time zone of your location.

Select **Adv Setting** > **Time Zone**. The following screen displays.

Figure 74 LCD Menu: Time Zone

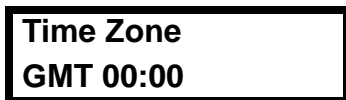

Use the ▲ ▼ keys to cycle through the time zones. Press ◀ to go back to the previous menu when you are done.

Choose the time zone of your location. This will set the time difference between your time zone and Greenwich Mean Time (GMT).

6.14 Date Format

Use this menu to select the date format that shows on the V300's LCD.

Select **Adv Setting** > **Date Format**. The following screen displays.

Figure 75 LCD Menu: Date Format



Use the ▲ ▼ keys to cycle through the date format choices. Press ◀ to go back to the previous menu when you are done.

The Web Configurator

7.1 Overview

This chapter describes how to access the V300's web configurator and provides an overview of its screens.

7.2 Accessing the Web Configurator

- 1 Make sure your hardware is properly connected and prepare your computer or computer network to connect to the V300 (refer to the Quick Start Guide).
- 2 Launch your web browser.
- 3 Enter the V300's IP address as the URL. The V300 is set to get an IP address automatically. Use the **System Info > IP Address** LCD screen to find it out (see [Section 5.5 on page 55](#)).

Note: If the V300 is not connected to a network, use the management IP address. The default management IP address is 192.168.5.1.

The following screen displays.

Figure 76 Password Screen



ZyXEL

ZyXEL V300 IP-PHONE

Welcome to your phone Configuration Interface

Enter your password and click "Login"

Username:

Password:

(max. 8 alphanumeric, printable characters and no spaces)

Note:
Please turn on the Javascript and ActiveX control setting on Internet Explorer.

Login Reset

- 4 Type "admin" as the default username and "1234" as the password and click **Login**. Both of these are the device defaults.
- 5 It is strongly recommended that you change your password in the screen that displays next.

Note: If you do not change your password, anyone who knows the default password can access your phonebook and SIP account information over the network.

- 6 Type a new password (and retype it to confirm) then click **Apply**. Alternatively, click **Ignore**.

Note: If you do not change the password, the following screen appears every time you log in.

Figure 77 Change Password Screen

ZyXEL

Please enter a new password

Your IP Phone is currently using the default password. To protect your network from unauthorized users we suggest you change your password at this time. Please select a new password that will be easy to remember yet difficult for others to guess. We suggest you combine text with numbers to make it more difficult for an intruder to guess.

The administrator password should must be between 4 - 8 digit.

New Password :

Retype to Confirm :

The **Status** screen displays.

Figure 78 The Status Screen

The screenshot shows the ZyXEL V300 IP-Phone web configurator interface. The title bar (A) displays the ZyXEL logo and the page title 'Status'. The navigation panel (B) on the left includes links for Network, Ethernet, VoIP, SIP, Phone, Phone book, Maintenance, System, Logs, and Tools. The main window (C) contains several sections: Device Information, System Status, Interface Status, VoIP Status, and Summary. The status bar (D) at the bottom shows a message icon and the text 'Message Ready'.

Device Information

System Name:	V300-Series
Firmware Version:	V1.20(AOW.0)b1
Ethernet Information	
- IP Address:	172.23.26.133
- IP Subnet Mask:	255.255.255.0
- MAC:	00:19:CB:D9:A0:66
- DHCP:	Client

System Status

System Uptime:	12 min
Current Date/Time:	Thu Jan 1 00:12:46 UTC+0800
System Resource:	
- CPU Usage:	6%
- Memory Usage:	96%

Interface Status

Interface	Status	Rate
Ethernet	Up	100 Mbps FULL

VoIP Status

Account	Registration	URI
1	<input type="button" value="Register"/> Unregister	anonymous
2	<input type="button" value="Register"/> Unregister	

Summary

VoIP Statistics ([Details..](#)) Packet Statistics ([Details..](#))

As illustrated above, the web configurator screen is divided into four parts.

- **A** - title bar
- **B** - navigation panel
- **C** - main window
- **D** - status bar

7.2.1 Title Bar

The title bar has some icons in the upper right corner.



The icons have the following functions.

Table 18 Web Configurator Icons in the Title Bar

ICON	DESCRIPTION
	Language: At the time of writing, only English is supported.
	Help: Click this to see online help related to the current screen.
	Logout: Click this icon to log out of the web configurator.

7.2.2 Navigation Panel

Use the menu items on the navigation panel to open screens and configure the V300's features. The following table describes the menu items.

Table 19 Navigation Panel Summary

LINK	TAB	FUNCTION
Status		This screen contains administrative and system-related information.
Network		
Ethernet	Internet Connection	Use this screen to configure ISP parameters, WAN IP address assignment and other advanced properties.
	Mgmt Port	Use this screen to set the V300's management IP address.
VoIP		
SIP	SIP Settings	Use this screen to configure your V300's Voice over IP settings.
	QoS	Use this screen to configure your V300's Quality of Service settings for VoIP.
Phone	Phone Settings	Use this screen to configure general phone settings, including volume levels and ringtone selection.
	Region	Use this screen to select your location.
	Speed Dial Settings	Use this screen to configure speed dial for phone numbers that you call often.
	Programmable Feature Key Settings	Use this screen configure the phone's programmable feature keys.

Table 19 Navigation Panel Summary

LINK	TAB	FUNCTION
Phone Book	Call Forward	Use this screen to redirect incoming calls to other phone numbers.
	Contact List	Use this screen to view, edit and add to your list of phonebook entries.
	Group List	Use this screen to view and edit the groups to which your phonebook entries belong.
	Block List	Use this screen to view and edit the phone numbers that you prevent from calling you.
	DND White List	Use this screen to view and edit the list of people who can call you even when DND (Do Not Disturb) is turned on.
Maintenance		
System	General	This screen contains administrative and system-related information and also allows you to change your password.
	Time Setting	Use this screen to change your V300's time and date.
	Dynamic DNS	Use this screen to map your current dynamic IP address with one or many dynamic DNS services so that anyone can contact you.
	Clock Alarm Setting	Use this screen to set your V300's three built-in clock alarms.
Logs	View Log	Use this screen to display your device's logs.
	SIP Message	Use this screen to view SIP server messages and responses.
Tools	Firmware	Use this screen to upload firmware to your device.
	Configuration	Use this screen to backup and restore your device's configuration (settings) or reset the factory default settings.
	Restart	This screen allows you to reboot the V300 without turning the power off.
	Ring Maintenance	Use this screen to upload files to the V300 and use them as ringtones.
	Packet Mirror	Use this screen to send data packets from the V300 to another IP address, where they can be analyzed to clarify Internet-related issues.

7.2.3 Main Window

The main window displays information and configuration fields. It is discussed in the rest of this document.

Right after you log in, the **Status** screen is displayed. See [Chapter 8 on page 89](#) for more information about the **Status** screen.

7.2.4 Status Bar

Check the status bar when you click **Apply** or **OK** to verify that the configuration has been updated.

The Status Screens

8.1 Overview

Use the **Status** screens to see the current status of the V300, its system resources, interfaces, and SIP accounts. You can also register and unregister SIP accounts and view detailed traffic and VoIP statistics.

8.1.1 What You Can Do in this Chapter

- The **Status** screen lets you see the current status of the V300. ([Section 8.2 on page 90](#)).
- The **Packet Statistics** sub-screen lets you view Ethernet data transmission information for your device ([Section 8.3 on page 92](#)).
- The **VoIP Statistics** sub-screen lets you view call statistics ([Section 8.4 on page 93](#)).

8.2 Status Screen

This screen displays the overall status and performance statistics of your device. Click **Status** to display it.

Figure 79 Status Screen

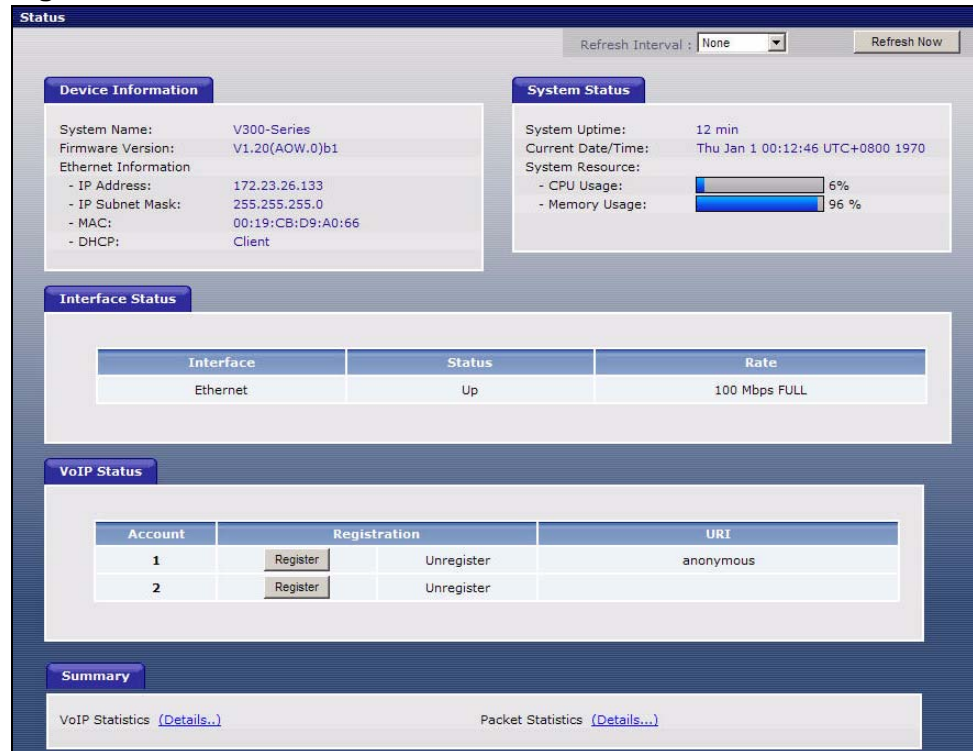

Each field is described in the following table.

Table 20 Status Screen

LABEL	DESCRIPTION
Refresh Interval	Enter how often you want the V300 to update this screen.
Refresh Now	Click this to update this screen immediately.
Device Information	
System Name	This field displays the V300's system name. It is used for identification. You can change this in the Maintenance > System > General screen's System Name field.
Firmware Version	This field displays the current version of the firmware inside the device. It also shows the date the firmware version was created. You can change the firmware version by uploading new firmware in Maintenance > Tools > Firmware .
IP Address	This field displays the current IP address of the V300 on the LAN.
IP Subnet Mask	This field displays the current subnet mask on the LAN.
MAC	This is the MAC (Media Access Control) or Ethernet address unique to your V300.

Table 20 Status Screen

LABEL	DESCRIPTION
DHCP	<p>This field displays what DHCP services the V300 is receiving from the LAN. Choices are:</p> <p>Client - The V300 is a DHCP client. It is receiving DHCP services.</p> <p>None - The V300 is not receiving DHCP services.</p> <p>You can change this in the Network > Ethernet > Internet Connection screen.</p>
System Status	
System Uptime	This field displays how long the V300 has been running since it last started up.
Current Date/Time	This field displays the current date and time in the V300. You can change this in Maintenance > System > Time Setting .
CPU Usage	This field displays what percentage of the V300's processing ability is currently in use. If this nears 100%, the V300 may slow down.
Memory Usage	This field displays what percentage of the V300's memory is currently in use. If this nears 100%, the V300 may slow down. Some memory is required just to start the V300 and to run the web configurator. You can reduce the memory usage by deleting rules in functions such as call forwarding, speed dial entries, and contact list entries.
Interface Status	
Interface	This column displays each interface of the V300.
Status	<p>This field indicates whether or not the V300 is using the interface.</p> <p>This field displays Up when the V300 is using the interface and Down when the V300 is not using the interface.</p>
Rate	This displays the port speed and duplex setting. Ethernet port connections can be in half-duplex or full-duplex mode. Full-duplex refers to a device's ability to send and receive simultaneously, while half-duplex indicates that traffic can flow in only one direction at a time. The Ethernet port must use the same speed or duplex mode setting as the peer Ethernet port in order to connect.
VoIP Status	
Account	This column displays each SIP account in the V300.
Registration	<p>This field displays the current registration status of the SIP account. You have to register a SIP account with a SIP server to use VoIP.</p> <p>If the SIP account is already registered with the SIP server,</p> <p>Click Unregister to delete the SIP account's registration in the SIP server. This does not cancel your SIP account, but it deletes the mapping between your SIP identity and your IP address or domain name.</p> <p>The second field displays Registered.</p> <p>If the SIP account is not registered with the SIP server,</p> <p>Click Register to have the V300 attempt to register the SIP account with the SIP server.</p> <p>The second field displays Unregister.</p>

Table 20 Status Screen

LABEL	DESCRIPTION
URI	This field displays the account number and service domain of the SIP account. You can change these in VoIP > SIP > SIP Settings .
Summary	
VoIP Statistics	Click this link to view statistics about your VoIP usage.
Packet Statistics	Click this link to view port status and packet specific statistics.

8.3 Packet Statistics

This screen displays read-only information here includes port status and packet specific statistics. Also provided are "system up time" and "poll interval(s)". The **Poll Interval(s)** field is configurable. To access it, open the **Status** screen (see [Section 8.2 on page 90](#)), and click **(Details...)** next to **Packet Statistics**.

Figure 80 Packet Statistics

Port	Status	TxPkts	RxPkts	Collisions	Tx B/s	Rx B/s	Up Time
Ethernet	100M/Full	1286	36497	0	26	156	5:41

System Up Time : 5:41

Poll Interval(s) : 0 sec Set Interval Stop

The following table describes the fields in this screen.

Table 21 Packet Statistics

LABEL	DESCRIPTION
Packet Statistics	
Port	This column displays each interface of the V300.
Status	This displays the port speed and duplex setting.
TxPkts	This field displays the number of packets transmitted on this interface.
RxPkts	This field displays the number of packets received on this interface.
Collisions	This field displays the number of collisions on this port.
Tx B/s	This field displays the number of bytes transmitted in the last second.
Rx B/s	This field displays the number of bytes received in the last second.

Table 21 Packet Statistics (continued)

LABEL	DESCRIPTION
Up Time	This field displays the elapsed time this interface has been connected.
System up Time	This is the elapsed time the system has been on.
Poll Interval(s)	Type the time interval (in seconds) for the browser to refresh system statistics.
Set Interval	Click this button to apply the new poll interval you entered in the Poll Interval field.
Stop	Click this button to halt the refreshing of the system statistics.

8.4 VoIP Statistics

This screen displays SIP registration information, status of calls and VoIP traffic statistics. To access it, open the **Status** screen (see [Section 8.2 on page 90](#)), and click **(Details...)** next to **VoIP Statistics**.

Figure 81 VoIP Statistics

VoIP Statistics							
SIP Status:							
Account	Registration	Last Registration	URI	Protocol	Message Waiting	Last Incoming Number	Last Outgoing Number
1	Registered	Thu Apr 23 08:44:33 2009	5002@172.23.31.42	udp	No		
2	Unregister			udp	No		
Call Statistics:							
Call	1	2	3	4			
Peer Number							
Status	Idle	Idle	Idle	Idle			
Codec							
Duration							
Tx Rate	0	0	0	0			
Rx Rate	0	0	0	0			
Packets Sent	0	0	0	0			
Packets Recv	0	0	0	0			

Each field is described in the following table.

Table 22 VoIP Statistics

LABEL	DESCRIPTION
SIP Status	
Account	This column displays each SIP account in the V300.
Registration	This field displays the current registration status of the SIP account. You can change this in the Status screen. <ul style="list-style-type: none"> • Registered - The SIP account is registered with a SIP server. • Unregister - The SIP account has failed to register with a SIP server, or is not active.
Last Registration	This field displays the last time you successfully registered the SIP account. It displays N/A if you never successfully registered this account.
URI	This field displays the account number and service domain of the SIP account. You can change these in VoIP > SIP > SIP Settings .
Protocol	This field displays the transport protocol the SIP account uses. SIP accounts always use UDP.
Message Waiting	This field indicates whether or not there are any messages waiting for the SIP account.
Last Incoming Number	This field displays the last number that called the SIP account. It displays N/A if no number has ever dialed the SIP account.
Last Outgoing Number	This field displays the last number the SIP account called. It displays N/A if the SIP account has never dialed a number.
Call Statistics	
Call	This field displays the V300's line number.
Peer Number	This field displays the SIP number of the person on the other end of the line, when a call is in progress.
Status	This field indicates whether the line is active or not. <ul style="list-style-type: none"> • Idle - The line is not active. • Dial - the line is active and a connection to a SIP server has been made, but a call is not in progress. • Dialing - the V300 is initiating a call on this line. • Ringling - the V300 has initiated a call, and the phone at the other end is ringing. • Connected - a call is in progress on this line. • Disconnect - the line is active, but the connection with the SIP server has been terminated. • Hold - a call on this line is on hold. • Waiting - another line is active, and this line has an incoming call that has not been answered. • Transfer - a call on this line is waiting to be transferred. • Transferred - a call on this line has been transferred to another number, and is still ongoing. • Incoming - an incoming call on this line is waiting to be answered. • Busy - the V300 has tried to initiate a call, but the phone at the other end is engaged.

Table 22 VoIP Statistics

LABEL	DESCRIPTION
Codec	This field displays what voice codec (coder/decoder) is being used for a current VoIP call.
Duration	This field displays how long the current call has lasted.
Packets Sent	This field displays the number of packets the V300 has transmitted in the current call.
Packets Recv	This field displays the number of packets the V300 has received in the current call.
Tx Rate	This field displays how quickly the V300 has transmitted packets in the current call. The rate is the average number of bytes transmitted per second.
Rx Rate	This field displays how quickly the V300 has received packets in the current call. The rate is the average number of bytes transmitted per second.
Poll Interval(s)	Enter how often you want the V300 to update this screen, and click Set Interval .
Set Interval	Click this to make the V300 update the screen based on the amount of time you specified in the Poll Interval field.
Stop	Click this to make the V300 stop updating the screen.

Network Setup

9.1 Overview

This chapter discusses how to configure the V300's network settings.

9.1.1 What You Can Do in This Chapter

- The **Internet Connection** screen lets you change your V300's Internet access settings ([Section 9.2 on page 99](#)).
- The **Management Port** screen lets you configure the management IP address of the V300 ([Section 9.3 on page 100](#)).

9.1.2 What You Need to Know About Network Setup

The following terms and concepts may help you as you read through this chapter.

IP Address Assignment

Every computer on the Internet must have a unique IP address. If your networks are isolated from the Internet (for instance, only between your two branch offices) you can assign any IP addresses to the hosts without problems. However, the Internet Assigned Numbers Authority (IANA) has reserved the following three blocks of IP addresses specifically for private networks.

Table 23 Private IP Address Ranges

10.0.0.0	-
10.255.255.255	
172.16.0.0	-
172.31.255.255	
192.168.0.0	-
192.168.255.255	

You can obtain your IP address from the IANA, from an ISP or have it assigned by a private network. If you belong to a small organization and your Internet access is through an ISP, the ISP can provide you with the Internet addresses for your local networks. On the other hand, if you are part of a much larger organization, you should consult your network administrator for the appropriate IP addresses.

Note: Regardless of your particular situation, do not create an arbitrary IP address; always follow the guidelines above. For more information on address assignment, please refer to RFC 1597, Address Allocation for Private Internets and RFC 1466, Guidelines for Management of IP Address Space.

IP Address and Subnet Mask

Similar to the way houses on a street share a common street name, computers on a LAN share one common network number.

Where you obtain your network number depends on your particular situation. If the ISP or your network administrator assigns you a block of registered IP addresses, follow their instructions in selecting the IP addresses and the subnet mask.

If the ISP did not explicitly give you an IP network number, then most likely you have a single user account and the ISP will assign you a dynamic IP address when the connection is established. The Internet Assigned Number Authority (IANA) reserved this block of addresses specifically for private use; please do not use any other number unless you are told otherwise. Let's say you select 192.168.1.0 as the network number; which covers 254 individual addresses, from 192.168.1.1 to 192.168.1.254 (zero and 255 are reserved). In other words, the first three numbers specify the network number while the last number identifies an individual computer on that network.

Once you have decided on the network number, pick an IP address that is easy to remember, for instance, 192.168.1.2, for your device, but make sure that no other device on your network is using that IP address.

The subnet mask specifies the network number portion of an IP address. Your device will compute the subnet mask automatically based on the IP address that you entered. You don't need to change the subnet mask computed by the device unless you are instructed to do otherwise.

PPPoE Encapsulation

The V300 supports PPPoE (Point-to-Point Protocol over Ethernet). PPPoE is an IETF standard (RFC 2516) specifying how a personal computer (PC) interacts with a broadband modem (DSL, cable, wireless, etc.) connection.

For the service provider, PPPoE offers an access and authentication method that works with existing access control systems (for example Radius).

One of the benefits of PPPoE is the ability to let you access one of multiple network services, a function known as dynamic service selection. This enables the service provider to easily create and offer new IP services for individuals.

Operationally, PPPoE saves significant effort for both you and the ISP or carrier, as it requires no specific configuration of the broadband modem at the customer site.

By implementing PPPoE directly on the V300 (rather than individual computers), the computers on the LAN do not need PPPoE software installed, since the V300 does that part of the task. Furthermore, with NAT, all of the LANs' computers will have access.

9.2 Internet Connection

Use this screen to change your V300's Internet access settings. Click **Network > Internet Connection**.

Figure 82 Network > Internet Connection

The following table describes the labels in this screen.

Table 24 Network > Internet Connection

LABEL	DESCRIPTION
Ethernet TCP/IP Settings	
Get automatically from DHCP	Select this option if your ISP did not give you an IP address.
Use Fixed IP Address	Select this option If your ISP assigned a fixed IP address. Enter the address information in the following fields.
IP Address	Enter your WAN IP address in this field if you selected Use Fixed IP Address .
IP Subnet Mask	Enter the IP Subnet Mask in this field.
Gateway IP Address	Enter a Gateway IP Address (if your ISP gave you one) in this field.

Table 24 Network > Internet Connection

LABEL	DESCRIPTION
Primary DNS Secondary DNS	Enter the DNS (Domain Name Service) servers, if provided by your ISP.
PPPoE	
Use PPPoE Client	Select this if your V300 is a PPPoE client.
PPPoE User Name	Type the user name given to you by your ISP.
Password	Type the password associated with the user name above.
Apply	Click this to save your changes.
Reset	Click this to reload the previous configuration for this screen.

9.3 Management Port

Use this screen to configure the management IP address of the V300. You can use this IP address to connect to the V300 even when its WAN IP address is in a different subnet. Your computer must be in the same subnet as the management IP address to use it.

Click **Network > Ethernet > Mgnt Port**. The following screen displays.

Figure 83 Network > Mgnt Port

The screenshot shows a web interface for configuring the management IP address. At the top, there are two tabs: 'Internet Connection' and 'Mgnt Port', with 'Mgnt Port' selected. Below the tabs, the title 'Management IP Address' is displayed. A message states: 'This management IP address can be on a different subnet from the Ethernet port's IP address, but the computer you use for management must be on the same subnet as this management IP address.' Below this message, there is a text input field labeled 'IP Address' containing the value '192.168.5.1'. At the bottom of the form, there are two buttons: 'Apply' and 'Reset'.

The following table describes the labels in this screen.

Table 25 Network > Mgnt Port

LABEL	DESCRIPTION
Management IP Address	
IP Address	Enter the new management IP address you want the V300 to use.
Apply	Click this to save your changes.
Reset	Click this to reload the previous configuration for this screen.

SIP Account Setup

10.1 Overview

This chapter discusses the V300's **VoIP** > **SIP** screens.

10.1.1 What You Can Do in This Chapter

- The **SIP Settings** screen lets you maintain basic information about each SIP account ([Section 10.2 on page 109](#)).
- The **Advanced SIP Setup** screen lets you maintain advanced settings for each SIP account ([Section 10.2.1 on page 113](#)).
- The **SIP QoS** screen lets you maintain ToS and VLAN settings for the V300 ([Section 10.3 on page 117](#)).

10.1.2 What You Need to Know About Network Setup

The following terms and concepts may help you as you read through this chapter.

VoIP

VoIP (Voice over IP) is the sending of voice signals over the Internet Protocol. This allows you to make phone calls and send faxes over the Internet at a fraction of the cost of using the traditional circuit-switched telephone network. You can also use servers to run telephone service applications like PBX services and voice mail. Internet Telephony Service Provider (ITSP) companies provide VoIP service. A company could alternatively set up an IP-PBX and provide its own VoIP service.

Circuit-switched telephone networks require 64 kilobits per second (kbps) in each direction to handle a telephone call. VoIP can use advanced voice coding techniques with compression to reduce the required bandwidth.

SIP

The Session Initiation Protocol (SIP) is an application-layer control (signaling) protocol that handles the setting up, altering and tearing down of voice and multimedia sessions over the Internet.

SIP signaling is separate from the media for which it handles sessions. The media that is exchanged during the session can use a different path from that of the signaling. SIP handles telephone calls and can interface with traditional circuit-switched telephone networks.

SIP Identities

A SIP account uses an identity (sometimes referred to as a SIP address). A complete SIP identity is called a SIP URI (Uniform Resource Identifier). A SIP account's URI identifies the SIP account in a way similar to the way an e-mail address identifies an e-mail account. The format of a SIP identity is SIP-Number@SIP-Service-Domain.

SIP Number

The SIP number is the part of the SIP URI that comes before the "@" symbol. A SIP number can use letters like in an e-mail address (johndoe@your-ITSP.com for example) or numbers like a telephone number (1122334455@VoIP-provider.com for example).

SIP Service Domain

The SIP service domain of the VoIP service provider (the company that lets you make phone calls over the Internet) is the domain name in a SIP URI. For example, if the SIP address is 1122334455@VoIP-provider.com, then "VoIP-provider.com" is the SIP service domain.

SIP Call Progression

The following figure displays the basic steps in the setup and tear down of a SIP call. **A** calls **B**.

Table 26 SIP Call Progression

A		B
1. INVITE		
		2. Ringing
		3. OK
4. ACK		
	5. Dialogue (voice traffic)	
6. BYE		
		7. OK

- 1 A** sends a SIP INVITE request to **B**. This message is an invitation for **B** to participate in a SIP telephone call.

- 2 **B** sends a response indicating that the telephone is ringing.
- 3 **B** sends an OK response after the call is answered.
- 4 **A** then sends an ACK message to acknowledge that **B** has answered the call.
- 5 Now **A** and **B** exchange voice media (talk).
- 6 After talking, A hangs up and sends a BYE request.
- 7 **B** replies with an OK response confirming receipt of the BYE request and the call is terminated.

SIP Client Server

SIP is a client-server protocol. A SIP client is an application program or device that sends SIP requests. A SIP server responds to the SIP requests.

When you use SIP to make a VoIP call, it originates at a client and terminates at a server. A SIP client could be a computer or a SIP phone. One device can act as both a SIP client and a SIP server.

SIP User Agent

A SIP user agent can make and receive VoIP telephone calls. This means that SIP can be used for peer-to-peer communications even though it is a client-server protocol. In the following figure, either **A** or **B** can act as a SIP user agent client to initiate a call. **A** and **B** can also both act as a SIP user agent to receive the call.

Figure 84 SIP User Agent



SIP Proxy Server

A SIP proxy server receives requests from clients and forwards them to another server.

In the following example, you want to use client device **A** to call someone who is using client device **C**.

- 1 The client device (**A** in the figure) sends a call invitation to the SIP proxy server (**B**).

- 2 The SIP proxy server forwards the call invitation to **C**.

Figure 85 SIP Proxy Server

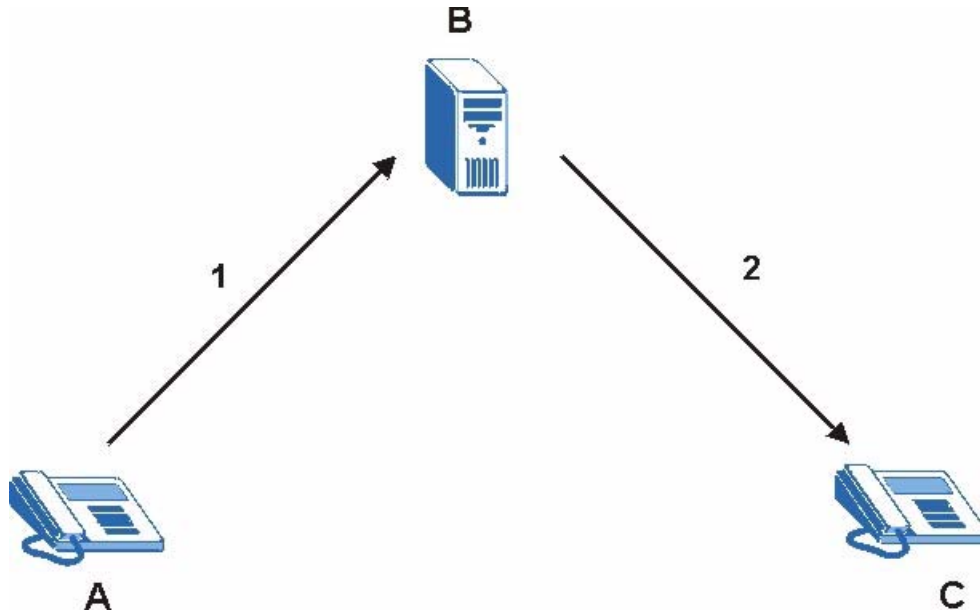

SIP Redirect Server

A SIP redirect server accepts SIP requests, translates the destination address to an IP address and sends the translated IP address back to the device that sent the request. Then the client device that originally sent the request can send requests to the IP address that it received back from the redirect server. Redirect servers do not initiate SIP requests.

In the following example, you want to use client device **A** to call someone who is using client device **C**.

- 1 Client device **A** sends a call invitation for **C** to the SIP redirect server (**B**).
- 2 The SIP redirect server sends the invitation back to **A** with **C**'s IP address (or domain name).

- 3 Client device **A** then sends the call invitation to client device **C**.

Figure 86 SIP Redirect Server

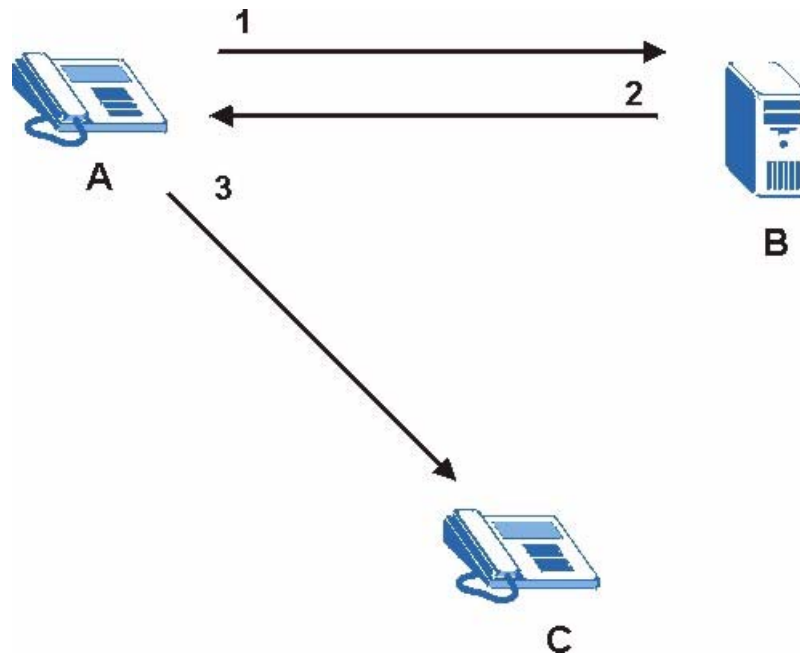

SIP Register Server

A SIP register server maintains a database of SIP identity-to-IP address (or domain name) mapping. The register server checks your user name and password when you register.

RTP

When you make a VoIP call using SIP, the RTP (Real time Transport Protocol) is used to handle voice data transfer. See RFC 1889 for details on RTP.

NAT and SIP

NAT (Network Address Translation - NAT, RFC 1631) is the translation of the IP address of a host in a packet, for example, the source address of an outgoing packet, used within one network to a different IP address known within another network.

The V300 must register its public IP address with a SIP register server. If there is a NAT router between the V300 and the SIP register server, the V300 probably has a private IP address. The V300 lists its IP address in the SIP message that it sends to the SIP register server. NAT does not translate this IP address in the SIP message. The SIP register server gets the V300's IP address from inside the SIP message and maps it to your SIP identity. If the V300 has a private IP address listed in the SIP message, the SIP server cannot map it to your SIP identity.

Use STUN or outbound proxy to allow the V300 to list its public IP address in the SIP messages.

STUN

STUN (Simple Traversal of User Datagram Protocol (UDP) through Network Address Translators) allows the V300 to find the presence and types of NAT routers and/or firewalls between it and the public Internet. STUN also allows the V300 to find the public IP address that NAT assigned, so the V300 can embed it in the SIP data stream. STUN does not work with symmetric NAT routers or firewalls. See RFC 3489 for details on STUN.

The following figure shows how STUN works.

- 1 The V300 (**A**) sends SIP packets to the STUN server (**B**).
- 2 The STUN server (**B**) finds the public IP address and port number that the NAT router used on the V300's SIP packets and sends them to the V300.
- 3 The V300 uses the public IP address and port number in the SIP packets that it sends to the SIP server (**C**).

Figure 87 STUN

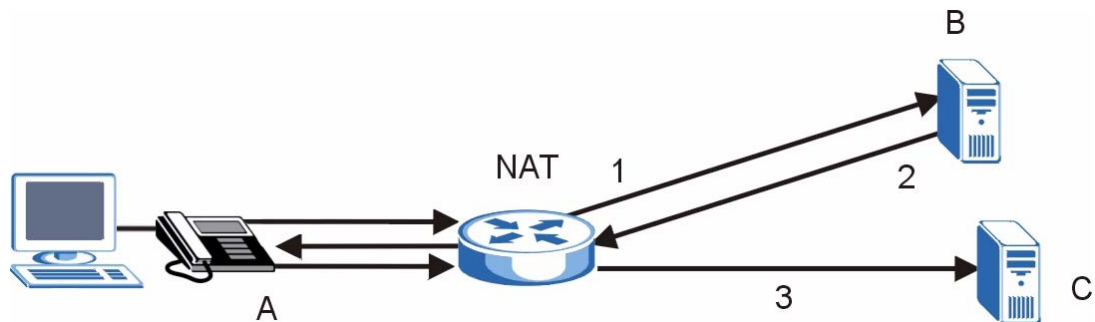

Outbound Proxy

Your VoIP service provider may host a SIP outbound proxy server to handle all of the V300's VoIP traffic. This allows the V300 to work with any type of NAT router and eliminates the need for STUN or a SIP ALG. Turn off a SIP ALG on a NAT router in front of the V300 to keep it from retranslating the IP address (since this is already handled by the outbound proxy server).

Voice Coding

A codec (coder/decoder) codes analog voice signals into digital signals and decodes the digital signals back into voice signals. The V300 supports the following codecs.

- **G.711** is a Pulse Code Modulation (PCM) waveform codec. PCM measures analog signal amplitudes at regular time intervals (sampling) and converts them into digital bits (quantization). Quantization “reads” the analog signal and then “writes” it to the nearest digital value. For this reason, a digital sample is usually slightly different from its analog original (this difference is known as “quantization noise”).

G.711 provides excellent sound quality but requires 64kbps of bandwidth.

- **G.722** is an Adaptive Differential Pulse Code Modulation (ADPCM) waveform codec. Differential (or Delta) PCM is similar to PCM, but encodes the audio signal based on the difference between one sample and a prediction based on previous samples, rather than encoding the sample’s actual quantized value. Many thousands of samples are taken each second, and the differences between consecutive samples are usually quite small, so this saves space and reduces the bandwidth necessary.

However, DPCM produces a high quality signal (high signal-to-noise ratio or SNR) for high difference signals (where the actual signal is very different from what was predicted) but a poor quality signal (low SNR) for low difference signals (where the actual signal is very similar to what was predicted). This is because the level of quantization noise is the same at all signal levels. Adaptive DPCM solves this problem by adapting the difference signal’s level of quantization according to the audio signal’s difference level. A low difference signal is given a higher quantization level, increasing its signal-to-noise ratio. This provides a similar sound quality at all signal levels.

G.722 samples audio at 16 kHz; twice the traditional rate of 8 kHz. G.722 provides excellent quality audio and requires 48 to 64 kbps.

- **G.723.1** is a Code Excited Linear Prediction (CELP) codec that compresses voice audio in 30 ms frames. G.723.1 operates at two bitrates: 6.3 kbps when sampling at 24 bytes or 5.3 kbps when sampling at 20 bytes per 30 ms frame.
- **G.726** is an ADPCM waveform codec that uses a lower bitrate than standard PCM conversion. G.726 operates at 16, 24, 32 or 40 kbps.
- **G.729** is an Analysis-by-Synthesis (AbS) hybrid waveform codec. It uses a filter based on information about how the human vocal tract produces sounds. The codec analyzes the incoming voice signal and attempts to synthesize it using its list of voice elements. It tests the synthesized signal against the original and, if it is acceptable, transmits details of the voice elements it used to make the synthesis. Because the codec at the receiving end has the same list, it can exactly recreate the synthesized audio signal.

G.729 provides good sound quality and reduces the required bandwidth to 8kbps.

MWI (Message Waiting Indication)

Enable Message Waiting Indication (MWI) enables your phone to give you a message–waiting (beeping) dial tone when you have one or more voice messages. Your VoIP service provider must have a messaging system that sends message-waiting-status SIP packets as defined in RFC 3842.

Quality of Service (QoS)

Quality of Service (QoS) refers to both a network's ability to deliver data with minimum delay and the networking methods used to provide bandwidth for real-time multimedia applications.

Type Of Service (ToS)

Network traffic can be classified by setting the ToS (Type Of Service) values at the data source (for example, at the V300) so a server can decide the best method of delivery, that is the least cost, fastest route and so on.

DiffServ

DiffServ is a class of service (CoS) model that marks packets so that they receive specific per-hop treatment at DiffServ-compliant network devices along the route based on the application types and traffic flow. Packets are marked with DiffServ Code Points (DSCPs) indicating the level of service desired. This allows the intermediary DiffServ-compliant network devices to handle the packets differently depending on the code points without the need to negotiate paths or remember state information for every flow. In addition, applications do not have to request a particular service or give advanced notice of where the traffic is going.

DSCP and Per-Hop Behavior

DiffServ defines a new DS (Differentiated Services) field to replace the Type of Service (TOS) field in the IP header. The DS field contains a 2-bit unused field and a 6-bit DSCP field which can define up to 64 service levels. The following figure illustrates the DS field.

Figure 88 DiffServ: Differentiated Service Field

DSCP (6-bit)	Unused (2-bit)
-----------------	-------------------

DSCP is backward compatible with the three precedence bits in the ToS octet so that non-DiffServ compliant, ToS-enabled network device will not conflict with the DSCP mapping.

The DSCP value determines the forwarding behavior, the PHB (Per-Hop Behavior), that each packet gets across the DiffServ network. Based on the marking rule, different kinds of traffic can be marked for different priorities of forwarding. Resources can then be allocated according to the DSCP values and the configured policies.

VLAN

Virtual Local Area Network (VLAN) allows a physical network to be partitioned into multiple logical networks. Only stations within the same group can communicate with each other.

Your V300 can add IEEE 802.1Q VLAN ID tags to voice frames that it sends to the network. This allows the V300 to communicate with a SIP server that is a member of the same VLAN group. Some ISPs use the VLAN tag to identify voice traffic and give it priority over other traffic.

10.2 The SIP Settings Screen

Use this screen to maintain basic information about each SIP account. Your VoIP service provider (the company that lets you make phone calls over the Internet)

should provide this. You can also enable and disable each SIP account. To access this screen, click **VoIP > SIP > SIP Settings**.

Figure 89 VoIP > SIP > SIP Settings

SIP Settings QoS

SIP Settings

SIP Account: SIP 1

Active

Account Name:

Number:

SIP Local Port: 5060 (1024-65535)

SIP Server Address:

SIP Server Port: 5060 (1024-65535)

REGISTER Server Address:

REGISTER Server Port: 5060 (1024-65535)

SIP Server Domains:

Send Caller ID

Voice Mail Number:

DNS SRV

Backup SIP Server

1st Backup SIP Server

SIP Server Address:

SIP Server Port: 5060 (1024-65535)

Register Server Address:

Register Server Port: 5060 (1024-65535)

SIP Server Domains:

2nd Backup SIP Server

SIP Server Address:

SIP Server Port: 5060 (1024-65535)

Register Server Address:

Register Server Port: 5060 (1024-65535)

SIP Server Domains:

Authentication

User Name:

Password:

Apply Advance Setup

Each field is described in the following table.

Table 27 VoIP > SIP > SIP Settings

LABEL	DESCRIPTION
SIP Settings	
SIP Account	Select the SIP account you want to see in this screen. At the time of writing, the V300 supports two SIP accounts.
Active	Select this if you want the V300 to use this account. Clear it if you do not want the V300 to use this account.
Account Name	Enter your SIP account name, if supplied by your SIP service provider.
Number	Enter your SIP number. In the full SIP URI, this is the part before the @ symbol. You can use up to 50 printable English keyboard characters.
SIP Local Port	Enter the V300's listening port number, if your VoIP service provider gave you one. Otherwise, keep the default value.
SIP Server Address	Enter the IP address or domain name of the SIP server provided by your VoIP service provider. You can use up to 32 printable English keyboard characters. It does not matter whether the SIP server is a proxy, redirect or register server.
SIP Server Port	Enter the SIP server's listening port number, if your VoIP service provider gave you one. Otherwise, keep the default value.
REGISTER Server Address	Enter the IP address or domain name of the SIP register server, if your VoIP service provider gave you one. Otherwise, enter the same address you entered in the SIP Server Address field. You can use up to 32 printable English keyboard characters.
REGISTER Server Port	Enter the SIP register server's listening port number, if your VoIP service provider gave you one. Otherwise, enter the same port number you entered in the SIP Server Port field.
SIP Server Domains	Enter the SIP server domain name. In the full SIP URI, this is the part after the @ symbol. You can use up to 32 printable English keyboard characters.
Send Caller ID	Select this if you want to send identification when you make VoIP phone calls. Clear this if you do not want to send identification.
Voice Mail Number	Enter the voicemail number associated with this SIP account.
DNS SRV	Select this to use the DNS server(s) you configured in the Network > Ethernet > Internet Connection screen.
Backup SIP Server	
1st / 2nd Backup SIP Server	Select the check box to have the V300 use the backup SIP server(s) you configure. If the V300 cannot use the server you configured in the SIP Settings section of this screen, it tries to use the backup server(s). It tries to use the 1st Backup SIP Server and, if it cannot connect, then tries to use the 2nd Backup SIP Server .
SIP Service Address	Enter the IP address or domain name of the backup SIP server provided by your VoIP service provider. You can use up to 32 printable English keyboard characters. It does not matter whether the SIP server is a proxy, redirect or register server.
SIP Service Port	Enter the backup SIP server's listening port number, if your VoIP service provider gave you one. Otherwise, keep the default value.

Table 27 VoIP > SIP > SIP Settings

LABEL	DESCRIPTION
Register Service Address	Enter the IP address or domain name of the backup SIP register server, if your VoIP service provider gave you one. Otherwise, enter the same address you entered in the SIP Service Address field for this backup server. You can use up to 32 printable English keyboard characters.
Register Service Port	Enter the backup SIP register server's listening port number, if your VoIP service provider gave you one. Otherwise, enter the same port number you entered in the SIP Service Port field for this backup server.
SIP Server Domains	Enter the SIP server domain name. In the full SIP URI, this is the part after the @ symbol. You can use up to 32 printable English keyboard characters.
Authentication	
User Name	Enter the user name for registering this SIP account, exactly as it was given to you. You can use up to 20 printable English keyboard characters.
Password	Enter the user name for registering this SIP account, exactly as it was given to you. You can use up to 20 printable English keyboard characters.
Apply	Click this to save your changes.
Advanced Setup	Click this to edit the advanced settings for this SIP account. The Advanced SIP Setup screen appears.

10.2.1 Advanced SIP Setup Screen

Use this screen to maintain advanced settings for each SIP account. Click **Advanced Setup** in **VoIP > SIP > SIP Settings**. The following screen displays.

Figure 90 VoIP > SIP > SIP Settings > Advanced

SIP Server Settings	
URL Type:	SIP
Expiration Duration:	3600 (1-65535) sec
Register Re-send timer:	180 (1-65535) sec
<input type="checkbox"/> Session Expires Active:	
Session Expires:	180 (90-3600) sec
Min-SE:	90 (90-1800) sec
RTP Port Range	
Start Port:	50000 (49152-65534)
End Port:	65534 (49152-65534)
Voice Compression	
Primary Compression Type:	G.711 u
Secondary Compression Type:	G.711 a
Third Compression Type:	G.729
DTMF Mode:	SIP INFO
STUN	
<input type="checkbox"/> Enable	
Server Address:	
Server Port:	3478 (1024-65535)
Use NAT	
<input type="checkbox"/> Enable	
Server Address:	
Server Port:	5060 (1024-65535)
OutBound Proxy	
<input type="checkbox"/> Enable	
Server Address:	
Server Port:	5060 (1024-65535)
NAT Keep Alive	
<input type="checkbox"/> Enable	
Keep Alive Interval:	60 (1-65535) sec
MWI(Message Waiting Indication)	
<input type="checkbox"/> Enable	
Expiration Time:	3600 (1-65535) sec
Hotline	
<input type="checkbox"/> Enable	
Delay Period before Hotline Activated:	15 (1-15) sec
Hotline Number:	
Call Forward	
<input type="checkbox"/> Enable	
RingBack Active	
<input type="checkbox"/> Enable	
MusicOnHold Active	
<input type="checkbox"/> Enable	
<input type="button" value="Apply"/> <input type="button" value="Back"/>	

Each field is described in the following table.

Table 28 VoIP > SIP > SIP Settings > Advanced Setup

LABEL	DESCRIPTION
SIP Server Settings	
URL Type	<p>Select whether or not to include the SIP service domain name when the V300 sends the SIP number.</p> <p>SIP - include the SIP service domain name</p> <p>TEL - do not include the SIP service domain name</p>
Expiration Duration	<p>Enter the number of seconds your SIP account is registered with the SIP register server before it is deleted. The V300 automatically tries to re-register your SIP account when one-half of this time has passed. (The SIP register server might have a different expiration.)</p>
Register Re-send timer	<p>Enter the number of seconds the V300 waits before it tries again to register the SIP account, if the first try failed or if there is no response.</p>
Session Expires Active	<p>Select this to have the V300 use the setting you configure in the Session Expire field. If you do not select this, the V300 does not automatically disconnect calls.</p>
Session Expires	<p>Enter the number of seconds the conversation can last before the call is automatically disconnected. Usually, when one-half of this time has passed, the V300 or the other party updates this timer to prevent this from happening.</p>
Min-SE	<p>Enter the minimum number of seconds the V300 accepts for a session expiration time when it receives a request to start a SIP session. If the request has a shorter time, the V300 rejects it.</p>
RTP Port Range	
Start Port End Port	<p>Enter the listening port number(s) for RTP traffic, if your VoIP service provider gave you this information. Otherwise, keep the default values.</p> <p>To enter one port number, enter the port number in the Start Port and End Port fields.</p> <p>To enter a range of ports,</p> <ul style="list-style-type: none"> • enter the port number at the beginning of the range in the Start Port field • enter the port number at the end of the range in the End Port field.
Voice Compression	

Table 28 VoIP > SIP > SIP Settings > Advanced Setup (continued)

LABEL	DESCRIPTION
	<p>Select the type of voice coder/decoder (codec) that you want the V300 to use.</p> <p>G.711 provides high voice quality but requires more bandwidth (64 kbps).</p> <ul style="list-style-type: none"> • G.711A is typically used in Europe. • G.711u is typically used in North America and Japan. • G.722 provides excellent sound quality and operates at 48 ~ 64 kbps. • G.726 operates at 16, 24, 32 or 40 kbps. • By contrast, G.729 requires only 8 kbps. • G.723 refers to G.723.1, which uses 5.3 or 6.4 kbps. <p>The V300 must use the same codec as the peer. When two SIP devices start a SIP session, they must agree on a codec.</p>
Primary Compression Type	Select the V300's first choice for voice coder/decoder.
Secondary Compression Type	Select the V300's second choice for voice coder/decoder.
Third Compression Type	Select the V300's third choice for voice coder/decoder.
DTMF Mode	<p>Control how the V300 handles the alphanumeric keypad tones. You should use the same mode your VoIP service provider uses.</p> <p>RFC 2833 - send the DTMF tones in RTP packets</p> <p>PCM - send the DTMF tones in the voice data stream. This method works best when you are using a codec that does not use compression (like G.711). Codecs that use compression (like G.729) can distort the tones.</p> <p>SIP INFO - send the DTMF tones in SIP messages.</p>
STUN	
Enable	<p>Select this if all of the following conditions are satisfied.</p> <ul style="list-style-type: none"> • There is a NAT router between the V300 and the SIP server. • The NAT router is not a SIP ALG. • Your VoIP service provider gave you an IP address or domain name for a STUN server. <p>Otherwise, clear this field.</p>
Server Address	Enter the IP address or domain name of the STUN server provided by your VoIP service provider.
Server Port	Enter the STUN server's listening port, if your VoIP service provider gave you one. Otherwise, keep the default value.
Use NAT	
Enable	Select this if your service provider has a NAT router between your phone and the SIP server.

Table 28 VoIP > SIP > SIP Settings > Advanced Setup (continued)

LABEL	DESCRIPTION
Server address	Enter the IP address or domain name of the NAT router.
Server Port	Enter the NAT router's listening port, if your network administrator gave you one. Otherwise, keep the default value.
Outbound Proxy	
Enable	Select this if your service provider has a SIP outbound server to handle voice calls. This allows the V300 to work with any type of NAT router and eliminates the need for STUN or a SIP ALG. Turn off any SIP ALG on a NAT router in front of the V300 to keep it from retranslating the IP address (since this is already handled by the outbound proxy server.
Server address	Enter the IP address or domain name of the SIP outbound proxy server.
Server Port	Enter the outbound proxy server's listening port, if your VoIP service provider gave you one. Otherwise, keep the default value.
NAT Keep Alive	
Enable	Select this to stop NAT routers between the V300 and SIP server (a SIP proxy server or outbound proxy server) from dropping the SIP session. The V300 does this by sending SIP notify messages to the SIP server based on the specified interval.
Keep Alive Interval	Enter how often (in seconds) the V300 should send SIP notify messages to the SIP server.
MWI (Message Waiting Indication)	
Enable	Select this if you want to hear a waiting (beeping) dial tone on your phone when you have at least one voice message. Your VoIP service provider must support this feature.
Expiration Time	Keep the default value, unless your VoIP service provider tells you to change it. Enter the number of seconds the SIP server should provide the message waiting service each time the V300 subscribes to the service. Before this time passes, the V300 automatically subscribes again.
Hot Line	
	Configure this option to have the V300 automatically dial the Hotline Number after the line is off the hook for the duration specified in the Delay Period option. This is especially useful for dialing emergency numbers.
Enable	Select this to enable the Hot Line feature.
Delay Period before Hotline Activated:	Enter the duration the phone can remain off the hook before automatically dialing the hotline number. You can set the delay from 1 to 15 seconds.
Hotline Number:	Enter the number to be dialed once the V300 has surpassed the delay period.
Call Forward	
Enable	Select this if you want the V300 to use the call forwarding rules you set up in the VoIP > Phone Book > Call Forward screen.
RingBack Active	

Table 28 VoIP > SIP > SIP Settings > Advanced Setup (continued)

LABEL	DESCRIPTION
Enable	Select this to turn the RingBack function on. When someone calls you, and the line is busy, the caller is given the option to set an automatic RingBack. When you finish your call, the V300 automatically calls the person who called you, and then rings to alert you once the caller picks up.
MusicOnHold Active	
Enable	Check this box if you want people to hear a customized recording when you put them on hold. This function depends on your service provider.
Apply	Click this to save your changes.
Back	Click this to return to the SIP Settings screen without saving your changes.

10.3 SIP QoS Screen

Use this screen to maintain ToS and VLAN settings for the V300. Click **VoIP > SIP > QoS**. The following screen displays.

Figure 91 VoIP > SIP > QoS

The screenshot shows the SIP QoS configuration interface. It features a navigation bar with 'SIP Settings' and 'QoS' tabs. The 'QoS' tab is active. Below the tabs, there are two main sections: 'TOS' and 'VLAN Tagging'. In the 'TOS' section, 'SIPTOS' and 'RTPTOS' are both set to 160. In the 'VLAN Tagging' section, 'Enable VLAN Tag' is unchecked, 'Voice VLAN Priority' is set to 0, and 'Voice VLAN ID' is set to 0. At the bottom right, there are 'Apply' and 'Reset' buttons.

Each field is described in the following table.

Table 29 VoIP > SIP > QoS

LABEL	DESCRIPTION
TOS	
SIPTOS	Enter the priority for SIP voice transmissions. The V300 creates Type of Service priority tags with this priority to voice traffic that it transmits.
RTPTOS	Enter the priority for RTP voice transmissions. The V300 creates Type of Service priority tags with this priority to RTP traffic that it transmits.
VLAN Tagging	

Table 29 VoIP > SIP > QoS

LABEL	DESCRIPTION
Enable VLAN Tag	Select this if the V300 has to be a member of a VLAN to communicate with the SIP server. Ask your network administrator if you are unsure. Otherwise, clear this field.
Voice VLAN Priority	If the V300 is a member of a VLAN group, you may choose a priority level for its VoIP traffic within the VLAN. The priority level is from 0-7 , with 0 being the lowest level and 7 being the highest level. You can assign the V300 with a higher traffic priority for better voice quality.
Voice VLAN ID	Enter the VLAN ID provided by your network administrator. Your LAN and gateway must be configured to use VLAN tags.
Apply	Click this to save your changes.
Reset	Click this to set every field in this screen to its last-saved value.

Phone Setup

11.1 Overview

This chapter discusses the V300's **Phone** screens.

11.2 What You Can Do in This Chapter

- The **Phone Settings** screen lets you adjust the V300's volume levels ([Section 11.3 on page 120](#)).
- The **Phone Region** screen lets you maintain settings that depend on which region of the world the V300 is in ([Section 11.4 on page 123](#)).
- The **Speed Dial Settings** screen provides shortcuts for dialing frequently used phone numbers ([Section 11.5 on page 124](#)).
- The **Programmable Feature Key Settings** screen program the custom keys on the V300 to automatically control certain supplementary call services, such as caller ID, call forwarding, call waiting, and so on ([Section 11.6 on page 125](#)).

11.3 Phone Settings Screen

Use this screen to configure basic phone settings like volume levels.

Click **VoIP > Phone > Phone Settings**. The following screen displays.

Figure 92 VoIP > Phone > Phone Settings

The screenshot displays the 'Phone Settings' configuration page. At the top, there are four tabs: 'Phone Settings' (selected), 'Region', 'Speed Dial Settings', and 'Programmable Feature Key Settings'. The page is organized into several sections, each with a title bar:

- Volume Control:** Contains seven volume settings, each with a dropdown menu:
 - Ring Volume: 6
 - Speaker Rx Volume: 6
 - Phone Rx Volume: 6
 - HeadSet Rx Volume: 6
 - Speaker Tx Volume: 8
 - Phone Tx Volume: 3
 - HeadSet Tx Volume: 3
- Ring Setting:** Contains 'Ring Type' with a dropdown menu set to 0.
- Voice Active Detection:** Contains a checkbox for 'VAD Support' which is unchecked.
- RTCP Support:** Contains a checkbox for 'RTCP Support' which is unchecked.
- Dialing Interval Select:** Contains 'Dialing Interval Select' with a text input field containing '3' and '(1-10) sec'.
- Call Waiting Setting:** Contains a checked checkbox for 'Call Waiting'.
- Paging Pick up Setting:** Contains two radio buttons: 'Speaker Mode' (selected) and 'Headset Mode'.
- Flexworker Mode:** Contains a checkbox for 'Enable Flexworker' which is unchecked.
- Remote Peer Display Type:** Contains 'Display Type' with a dropdown menu set to 'Name+Number'.

At the bottom of the page, there are two buttons: 'Apply' and 'Reset'.

Each field is described in the following table.

Table 30 VoIP > Phone > Phone Settings

LABEL	DESCRIPTION
Volume Control	
Ring Volume	Select this to set the volume of the V300's ringtone. 0 is the quietest and 12 is the loudest.
Speaker Rx Volume	Select this to set the internal speakerphone's inbound volume. This controls both the internal speaker and the internal microphone. 0 is the quietest and 12 is the loudest.
Phone RX Volume	Select this to set the handset's inbound volume. This controls both the handset's speaker and its microphone. 0 is the quietest and 12 is the loudest.
Headset RX Volume	Select this to set the inbound volume of an attached headset (or any device connected to the external speaker and/or microphone sockets). This controls both the handset's speaker (earpiece) and its microphone. 0 is the quietest and 12 is the loudest.
Speaker Tx Volume	Select this to set the internal speakerphone's outbound volume. This controls both the internal speaker and the internal microphone. 0 is the quietest and 12 is the loudest.
Phone Tx Volume	Select this to set the handset's outbound volume. This controls both the handset's speaker and its microphone. 0 is the quietest and 12 is the loudest.
Headset Tx Volume	Select this to set the outbound volume of an attached headset (or any device connected to the external speaker and/or microphone sockets). This controls both the handset's speaker (earpiece) and its microphone. 0 is the quietest and 12 is the loudest.
Ring Setting	
Ring Type	Select the ring tone you want to use for the V300. These are the same options as available on the phone itself through the Advanced Setting > Ring Setting menu. (For information, see Section 6.10 on page 78 for more information.)
Voice Active Detection	
VAD Support	Select this if the V300 should stop transmitting when you are not speaking. This reduces the bandwidth the V300 uses.
RTCP Support	
RTCP Support	Select this option if you want the V300 to transmit its connection statistics to the IP PBX. Doing this may increase the device's bandwidth. A single device should not make much of an impact but enough devices on a network using RTCP could. When activated, the VoIP Statistics screen displays more comprehensive data based on the data gathered with RTCP.
Dialing Interval Select	

Table 30 VoIP > Phone > Phone Settings

LABEL	DESCRIPTION
Dialing Interval Select (1-10) sec	Enter the number of seconds (1-10) between dials.
Call Waiting Setting	
Call Waiting	Select this to enable call waiting on your V300.
Paging Pick Up Setting	
Speaker Mode / Headset Mode	Select either Speaker or Headset as the preferred method for picking up pages.
Flexworker Mode	
Enable Flexworker	Select this to enable the Flexworker feature, which allows other people in the company to use this device in conjunction with their personal account settings. As soon as they log in, their account profile is uploaded from the IP PBX.
Remote Peer Display Type	
Display Type	<p>Select the type of information displayed on your V300 LCD screen when you receive a call. Options are:</p> <ul style="list-style-type: none"> • Full Content - This displays all available caller ID information. • Name+Number - This displays the caller's name and number in that order. • Number+Name - This displays the caller's number and name in that order. • Number Only - This displays just the caller's number. • Name Only - This displays just the caller's name.
Apply	Click this to save your changes and to apply them to the V300.
Reset	Click this to set every field in this screen to its last-saved value.

11.3.1 Voice Activity Detection/Silence Suppression

Voice Activity Detection (VAD) detects whether or not speech is present. This lets the V300 reduce the bandwidth that a call uses by not transmitting “silent packets” when you are not speaking.

11.3.2 Comfort Noise Generation

When using VAD, the V300 generates comfort noise when the other party is not speaking. The comfort noise lets you know that the line is still connected as total silence could easily be mistaken for a lost connection.

11.4 Phone Region Screen

Use this screen to maintain settings that depend on which region of the world the V300 is in. To access this screen, click **VoIP > Phone > Region**.

Figure 93 VoIP > Phone > Region

Each field is described in the following table.

Table 31 VoIP > Phone > Region

LABEL	DESCRIPTION
Region Setting	
Region Settings	Select the place in which the V300 is located.
Apply	Click this to save your changes.
Reset	Click this to set this screen to its last-saved value.

11.5 Speed Dial Settings Screen

Speed dial provides shortcuts for dialing frequently used phone numbers. You can map a phone number to an alphanumeric keypad key (**1** to **9**) and then use that keypad key to call the phone number (press and hold the key for one second or longer). Use this screen to add, edit, or remove speed-dial numbers for outgoing calls.

You also have to create speed-dial entries if you want to make peer-to-peer calls or call SIP numbers that use letters.

In peer-to-peer calls, you call another VoIP device directly without going through a SIP server. Enter the callee's SIP URI (such as "200@172.25.27.2"). The V300 sends SIP INVITE requests to the peer VoIP device when you use the speed dial entry.

You do not need to configure a SIP account in order to make a peer-to-peer VoIP call.

Click **VoIP > Phone > Speed Dial Settings**. The following screen displays.

Figure 94 Phone Book > Speed Dial

Each field is described in the following table.

Table 32 Phone Book > Speed Dial

LABEL	DESCRIPTION
Speed Dial Settings	
Speed Dial Key 1 ~ 9	Enter the SIP URI (peer-to-peer call) that you want the V300 to call when you use this speed dial key.

Table 32 Phone Book > Speed Dial

LABEL	DESCRIPTION
Apply	Click this to save your settings.
Reset	Click this to set every field in this screen to its last-saved value.

11.6 Programmable Feature Key Settings Screen

You can program the custom keys on the V300 to automatically control certain supplementary call services, such as caller ID, call forwarding, call waiting, and so on. These services are generally available from your VoIP service provider. The call functions available, and the codes you use to control them, may differ from one service provider to another.

Click **VoIP > Phone > Programmable Feature Key Setting**. The following screen displays.

Figure 95 Phone Book > Programmable Feature Key Settings

Each field is described in the following table.

Table 33 Phone Book > Programmable Feature Key Settings

LABEL	DESCRIPTION
Programmable Feature Key 1~6	Enter the feature code you want the V300 to use when you press this feature key.
Apply	Click this to save your settings.
Reset	Click this to set every field in this screen to its last-saved value.

The Phone Book

12.1 Overview

This chapter discusses the **Phone Book** screens.

Note: The V300 can hold a maximum of 200 private phone numbers and 200 public phone numbers. Public phone numbers are provided by the PBX to which your phone is connected, while private numbers are the ones you enter into your phone memory yourself.

12.1.1 What You Can Do in This Chapter

- The **Call Forward** screen lets you configure call forwarding for incoming calls ([Section 12.2 on page 127](#)).
- The **Contact List** screen lets you see, add and edit details of the contacts in your phonebook ([Section 12.3 on page 130](#)).
- The **Group List** screen lets you see and edit the calling groups to which your phonebook contacts belong ([Section 12.4 on page 131](#)).
- The **Block List** screen lets you see and edit details of the phone numbers that are prevented from making incoming calls to the V300 ([Section 12.5 on page 133](#)).
- The **DND White List** screen lets you see and edit details of people who can make incoming calls to the V300 even when you have DND (Do Not Disturb) turned on ([Section 12.6 on page 135](#)).

12.2 Call Forward Screen

Use this screen to configure call forwarding for incoming calls. When call forwarding is active, incoming calls are redirected to other phone numbers. You

can set up rules for all incoming calls, or have the V300 forward calls from specific numbers only.

Click **VoIP > Phone Book > Call Forward**. The following screen displays.

Figure 96 VoIP > Phone Book > Call Forward

The following table describes the labels in this screen.

Table 34 VoIP > Phone Book > Call Forward

LABEL	DESCRIPTION
Call Forward Setup	The V300 checks these rules, in the order in which they appear, after it checks the rules in the Advanced Setup section.
Active	Select this to turn call forwarding on. This setting applies to all call forwarding on the V300.
Allow Anonymous Call	Select this to allow incoming calls that do not carry caller ID. If this is not selected, the phone does not ring when someone tries to call you with caller ID deactivated.
Conditional Forward	Select this to forward all incoming calls under certain circumstances (if the phone is in use, if you do not answer, or if you have the Do Not Disturb function turned on).

Table 34 VoIP > Phone Book > Call Forward (continued)

LABEL	DESCRIPTION
Busy Forward to Number	Select this if you want the V300 to forward incoming calls to the specified phone number if the phone is busy (it does not matter which line is being used). Specify the phone number in the field on the right. If you have call waiting, the incoming call is forwarded to the specified phone number if you reject or ignore the second incoming call.
No Answer Forward to Number	Select this to forward all incoming calls if you do not answer the phone within the time you set in the No Answer Time field.
DND Forward	Select this to forward all incoming calls if you have DND (Do Not Disturb) turned on.
Unconditional Forward to Number	Select this if you want the V300 to forward all incoming calls to the specified phone number, regardless of other rules in the Forward to Number section. Specify the phone number in the Forward Number field.
Forward Number	Enter the phone number to which you want to forward incoming calls.
No Answer Time	This field is used by the No Answer Forward to Number feature and No Answer conditions. Enter the number of seconds the V300 should wait for you to answer an incoming call before it considers the call is unanswered.
Specific Active	Select this to turn on the specific call forwarding rules you set up in the Advanced Setup section of this screen. If you have Conditional Forwarding or Unconditional Forwarding turned on as well as specific call forwarding, the V300 applies the specific call forwarding rules first. If the incoming number does not match a specific call forwarding rule, the V300 applies the conditional or unconditional forwarding rule.
List Table	
Group List	Select this to see the phonebook entries belonging to each group.
Block List	Select this to see the phone numbers that are prevented from calling the V300.
DND White List	Select this to see which contacts (phonebook entries) are allowed to call the V300 even when DND (Do Not Disturb) is turned on.
Advanced Setup	The V300 checks these rules before it checks the rules in the Call Forward Setup section.
#	This field is a sequential value, and it is not associated with a specific rule. The sequence is important, however. The V300 checks each rule in order, and it only follows the first one that applies.
Activate	Select this to have the V300 use the specific call forwarding rule. Deselect it to ignore the rule.
Incoming Call Number	Enter the incoming phone number to which you want this rule to apply.
Forward to Number	Enter the phone number to which you want to forward calls from this number
Uncondition	Select this to always forward incoming calls from this number.
NoAnswer	Select this to forward incoming calls from this number if you do not answer the phone within the time you set in the No Answer Time field.

Table 34 VoIP > Phone Book > Call Forward (continued)

LABEL	DESCRIPTION
Busy	Select this to forward incoming calls from this number if the V300 is in use. It does not matter which line is being used.
DND	Select this to forward incoming calls from this number if you have DND (Do Not Disturb) turned on.
Apply	Click this to save your settings.
Reset	Click this to set every field in this screen to its last-saved value.

12.3 Contact List Screen

Use this screen to see, add and edit details of your contacts. Click **VoIP > Phone Book > Contact List**. The following screen displays.

Figure 97 VoIP > Phone Book > Contact List

The screenshot shows the 'Contact List' screen. At the top, there are tabs for 'Call Forward', 'Contact List' (selected), 'Group List', 'Block List', and 'DND White List'. Below the tabs is a 'Phone Book' section with a table. The table has columns: Item, Number, Name, Group, Assign Account, Block, Dnd White, and Modify. A single contact is listed with Item 1 and Number 1002. Below the table are buttons for 'Apply', 'Clear All', 'Backup', and 'Restore'.

The following table describes the labels in this screen.

Table 35 VoIP > Phone Book > Contact List

LABEL	DESCRIPTION
Phone Book	
Item	This shows the index number of the list entry. The V300 supports up to 200 phonebook entries.
Number	Enter the contact's phone number.
Name	Enter the contact's name.
Group	Select the group to which you want the contact to belong. Alternatively, leave Default selected if you do not wish to assign the contact to a group.
Assign Account	At the time of writing, the V300 supports a single SIP account.
Block	Select this if you want to prevent this contact from calling you.

Table 35 VoIP > Phone Book > Contact List (continued)

LABEL	DESCRIPTION
DND White	Select this if you want this contact to be able to call you even when DND (Do Not Disturb) is turned on.
Modify	Click the Add button to include the new entry in the phonebook, or to save the changes you made to an existing entry.
Phone Book Table	
Page	Select a page from the list to go to that page of contacts.
Sort By	Select a method for sorting the items in your phonebook.
Item	This shows the index number of the contact's entry.
Number	This is the contact's phone number.
Name	This is the contact's name.
Group	This is the calling group to which the contact belongs.
Assign Account	This is the SIP account the V300 always uses to call this contact. This shows None if you can use any SIP account to call the contact.
Block	This is selected if this contact is prevented from calling you.
DND White	This is selected if this contact can call you even when DND (Do Not Disturb) is turned on.
Modify	Click the Edit icon to change this entry's details. Click the Delete icon to remove the entry from the phonebook. If you do this, the information cannot be recovered.
Apply	Click this to save your settings.
Clear All	Click this to remove all the entries from the phonebook. If you do this, the information cannot be recovered.
Backup	Click this to save your phonebook as an *.ini file.
Restore	Click this restore a previously saved phonebook file. When you click the Restore button, a filename field, Browse button and Upload button appear. Use the Browse button to locate the previously saved phonebook book then click the Upload button to load it into the web configurator, which then updates your phone.

12.4 Group List Screen

Use this screen to see and edit the calling groups to which your phonebook contacts belong.

Note: You can also edit this information in the **VoIP > Phone Book > Contact List** screen.

Click **VoIP > Phone Book > Group List**. The following screen displays.

Figure 98 VoIP > Phone Book > Group List

The following table describes the labels in this screen.

Table 36 VoIP > Phone Book > Group List

LABEL	DESCRIPTION
Group List	
Group	Select the calling group you want to see. The list of group members displays in the Group List Table . Each group can have up to 200 members.
Group List Table	
Item	This is the index number of the group member's list entry.
Number	This is the contact's phone number.
Name	This is the contact's name.
Group	Select an entry from the list to move the contact to another group.
Assign Account	This shows the SIP account the V300 uses to call this contact, or None if you can use any account to call the contact.
Block	This is selected if the contact is prevented from calling you.
Apply	Click this to save your changes.
Reset	Click this to return to the fields in this screen to their last-saved values.

12.5 Block List Screen

Use this screen to see and edit details of the phone numbers that are prevented from making incoming calls to the V300.

Click **VoIP > Phone Book > Block List**. The following screen displays.

Figure 99 VoIP > Phone Book > Block List

The screenshot shows the 'Block List' screen with the following elements:

- Navigation tabs: Call Forward, Contact List, Group List, **Block List**, DND White List.
- Form fields: Item (1), Number, Name, Add, Page 1 (dropdown), Add From Phone Book.
- Table: Block List Table with columns Item, Number, Name, and Modify.

Item	Number	Name	Modify
1			
2			
3			
4			
5			
6			
7			
8			
9			
10			
11			
12			
13			
14			
15			
16			
17			
18			
19			
20			

The following table describes the labels in this screen.

Table 37 VoIP > Phone Book > Block List

LABEL	DESCRIPTION
Block List	
Item	This is the index number of the block list entry.
Number	Enter the phone number you want to block.
Name	Enter a name for this entry, or leave this field blank.
Add	Click this to include the details you entered into the block list.
Page	If you want to add an entry to the block list from the phonebook, select the entry's phonebook page and click Add From Phone Book .
Add From Phone Book	Click this to select an entry from the phonebook page shown in the Page field. The list of contact numbers displays. Click on the number you want to block.
Block List Table	

Table 37 VoIP > Phone Book > Block List (continued)

LABEL	DESCRIPTION
Item	This is the index number of the block list entry.
Number	This is the block list entry's phone number. Incoming calls from this phone number are prevented from calling you.
Name	This is the name associated with the blocked phone number, if configured.
Modify	Click the Edit icon to change this entry's details. Click the Delete icon to remove the entry from the block list. If you do this for an entry not in the phonebook, the information cannot be recovered.
Apply	Click this to save your settings.
Clear All	Click this to remove all the entries from the block list. If you do this for entries not in the phonebook, the information cannot be recovered.

12.6 DND White List Screen

Use this screen to see and edit details of people who can make incoming calls to the V300 even when you have DND (Do Not Disturb) turned on.

Click **VoIP > Phone Book > DND White List**. The following screen displays.

Figure 100 VoIP > Phone Book > DND White List

The screenshot shows the 'DND White List' screen with the following elements:

- Navigation tabs: Call Forward, Contact List, Group List, Block List, **DND White List**
- Section header: DND White List
- Form fields: Item (1), Number (input field), Name (input field), Add button, Page 1 dropdown, Add From Phone Book button
- Table: DND White List Table
- Table columns: Item, Number, Name, Modify
- Table rows: 1 through 20
- Modify column: Contains edit and delete icons for each row
- Buttons: Apply, Clear All

Item	Number	Name	Modify
1			
2			
3			
4			
5			
6			
7			
8			
9			
10			
11			
12			
13			
14			
15			
16			
17			
18			
19			
20			

The following table describes the labels in this screen.

Table 38 VoIP > Phone Book > DND White List

LABEL	DESCRIPTION
DND White List	
Item	This is the index number of the DND white list entry.
Number	Enter the phone number you want to add to the list.
Name	Enter a name for this entry, or leave this field blank.
Add	Click this to include the details you entered into the DND white list.
Page	If you want to add an entry to the DND white list from the phonebook, select the entry's phonebook page and click Add From Phone Book .
Add From Phone Book	Click this to select an entry from the phonebook page shown in the Page field. The list of contact numbers displays. Click on the number you want to add.
DND White List Table	
Item	This is the index number of the DND white list entry.
Number	This is the list entry's phone number. Incoming calls from this phone number can call you even when DND is turned on.
Name	This is the name associated with the entry's phone number, if configured.
Modify	Click the Edit icon to change this entry's details. Click the Delete icon to remove the entry from the DND white list. If you do this for an entry not in the phonebook, the information cannot be recovered.
Apply	Click this to save your settings.
Clear All	Click this to remove all the entries from the DND white list. If you do this for entries not in the phonebook, the information cannot be recovered.

System

13.1 Overview

Use the System screens to change the V300's system and domain name settings, change the password or configure time settings.

13.2 What You Can Do in This Chapter

- The **General** screen lets you change system settings and the web configurator password, or to set the administrator inactivity timer ([Section 13.3 on page 138](#)).
- The **Time Setting** screen lets you change your V300's time and date ([Section 13.4 on page 140](#)).
- The **Dynamic DNS** screen allows you to map your current dynamic IP address with one or many dynamic DNS services so that anyone can contact you ([Section 13.5 on page 142](#)).
- The **Clock Alarm Setting** screen allows you to set your V300's three built-in clock alarms ([Section 13.6 on page 144](#)).

13.3 General Screen

Use this screen to change system settings and the web configurator password, or to set the administrator inactivity timer.

Note: If you forget your password you will need to reset the device. See your Quick Start Guide for details.

Click **Maintenance > System > General**. The following screen displays.

Figure 101 Maintenance > System > General

The screenshot shows a web configuration interface divided into two main sections: System Setup and Password Setup. The System Setup section has three input fields: System Name (containing 'V300-Series'), Domain Name (containing 'zyxel.com'), and Administrator Inactivity Timer (containing '0' with a note '(seconds, 0 means no timeout, 0~900)'). The Password Setup section is divided into 'Admin Level' and 'User Level', each with three input fields for Old Password, New Password, and Retype to Confirm. At the bottom, there are 'Apply' and 'Reset' buttons.

The following table describes the labels in this screen.

Table 39 Maintenance > System > General

LABEL	DESCRIPTION
System Setup	
System Name	System Name is a unique name to identify the V300 in an Ethernet network. It is recommended you enter your computer's "Computer name" in this field. This name can be up to 30 alphanumeric characters long. Spaces are not allowed, but dashes "-" and underscores "_" are accepted.
Domain Name	Enter the domain name (if you know it) here. If you leave this field blank, the ISP may assign a domain name via DHCP. The domain name entered by you is given priority over the ISP assigned domain name.

Table 39 Maintenance > System > General (continued)

LABEL	DESCRIPTION
Administrator Inactivity Timer	Type how many seconds a management session can be left idle before the session times out. After it times out you have to log in with your password again. Very long idle timeouts may have security risks. The default is 0 seconds, which means a management session never times out, no matter how long it has been left idle.
Password Setup	<p>Set up both the Admin and User level passwords in this section.</p> <p>Both accounts can log into the web configurator and change its settings, but the User account has some limitations on what it is allowed to do.</p> <p>The User account:</p> <ul style="list-style-type: none"> • Cannot access the SIP screens or configure them. • Cannot access the Tools screens or configure them.
Old Password	Type in your existing system password ("1234" is the default password).
New Password	<p>Type your new system password.</p> <p>Note: The new password must be between 4 and 8 numerals (0 ~ 9) long. Letters, spaces and other characters are not allowed.</p> <p>Note that as you type a password, the screen displays an asterisk (*) for each character you type.</p>
Retype to Confirm	Retype your new system password for confirmation.
Apply	Click this to save your changes back to the device.
Reset	Click this to reload the previous configuration for this screen.

13.4 Time Setting Screen

To change your V300's time and date, click **Maintenance > System > Time Setting**. The screen appears as shown. Use this screen to configure the V300's time based on your local time zone.

Figure 102 Maintenance > Time Setting

The following table describes the labels in this screen.

Table 40 Maintenance > Time Setting

LABEL	DESCRIPTION
Current Time and Date	
Current Time	This field displays the time of your V300. Each time you reload this page, the V300 synchronizes the time with the time server.
Current Date	This field displays the date of your V300. Each time you reload this page, the V300 synchronizes the date with the time server.
Time and Date Setup	
Manual	Select this to enter the time and date manually. If you configure a new time and date, Time Zone and Daylight Saving at the same time, the new time and date you entered has priority and the Time Zone and Daylight Saving settings do not affect it.

Table 40 Maintenance > Time Setting (continued)

LABEL	DESCRIPTION
New Time (hh:mm:ss)	<p>This field displays the last updated time from the time server or the last time configured manually.</p> <p>When you set Time and Date Setup to Manual, enter the new time in this field and then click Apply.</p>
New Date (yyyy/mm/dd)	<p>This field displays the last updated date from the time server or the last date configured manually.</p> <p>When you set Time and Date Setup to Manual, enter the new date in this field and then click Apply.</p>
Get from Time Server	<p>Select this to have the V300 get the time and date from the time server you specify below.</p>
Time Server Address	<p>Select User Defined Time Server Address and enter the IP address or URL (up to 20 characters in length) of your time server. Check with your ISP/network administrator if you are unsure of this information.</p>
Time Server Interval	<p>Enter the duration between time checks. The V300 will only ping the time server to update itself once every <i>x</i> minutes where <i>x</i> is the value you enter here.</p>
Time Zone Setup	
Time Zone	<p>Choose the time zone of your location. This will set the time difference between your time zone and Greenwich Mean Time (GMT).</p>
Daylight Savings	<p>Daylight saving is a period from late spring to early fall when many countries set their clocks ahead of normal local time by one hour to give more daytime light in the evening.</p> <p>Select this option if you use Daylight Saving Time.</p>
Start Date	<p>Configure the day and time when Daylight Saving Time starts if you selected Daylight Savings. The o'clock field uses the 24 hour format. Here are a couple of examples:</p> <p>Daylight Saving Time starts in most parts of the United States on the first Sunday of April. Each time zone in the United States starts using Daylight Saving Time at 2 A.M. local time. So in the United States you would select First, Sunday, April and type 2 in the o'clock field.</p> <p>Daylight Saving Time starts in the European Union on the last Sunday of March. All of the time zones in the European Union start using Daylight Saving Time at the same moment (1 A.M. GMT or UTC). So in the European Union you would select Last, Sunday, March. The time you type in the o'clock field depends on your time zone. In Germany for instance, you would type 2 because Germany's time zone is one hour ahead of GMT or UTC (GMT+1).</p>

Table 40 Maintenance > Time Setting (continued)

LABEL	DESCRIPTION
End Date	<p>Configure the day and time when Daylight Saving Time ends if you selected Daylight Savings. The o'clock field uses the 24 hour format. Here are a couple of examples:</p> <p>Daylight Saving Time ends in the United States on the last Sunday of October. Each time zone in the United States stops using Daylight Saving Time at 2 A.M. local time. So in the United States you would select Last, Sunday, October and type 2 in the o'clock field.</p> <p>Daylight Saving Time ends in the European Union on the last Sunday of October. All of the time zones in the European Union stop using Daylight Saving Time at the same moment (1 A.M. GMT or UTC). So in the European Union you would select Last, Sunday, October. The time you type in the o'clock field depends on your time zone. In Germany for instance, you would type 2 because Germany's time zone is one hour ahead of GMT or UTC (GMT+1).</p>
Apply	Click this to save your changes back to the V300.
Reset	Click this to begin configuring this screen afresh.

13.5 Dynamic DNS

Dynamic DNS allows you to map your current dynamic IP address with one or many dynamic DNS services so that anyone can contact you. SIP IP phones can access the SIP server on the V300 using a domain name (for instance myhost.dhs.org, where myhost is a name of your choice) that will never change instead of using an IP address that changes each time you reconnect.

First of all, you need to have registered a dynamic DNS account with www.dyndns.org. This is for people with a dynamic IP from their ISP or DHCP server that would still like to have a domain name. The Dynamic DNS service provider will give you a password or key.

Click **Maintenance > System > Dynamic DNS**. The screen appears as shown. Use this screen to change your V300's DDNS settings.

Figure 103 Maintenance > DDNS

The following table describes the labels in this screen.

Table 41 Maintenance > System > DDNS

LABEL	DESCRIPTION
Enable Dynamic DNS	Select this to allow the V300 to use DDNS.
Service Provider	Select the type of service that you are registered for with your Dynamic DNS service provider.
Host name	Type the host name assigned to your V300 by your Dynamic DNS provider.
User Name	Type your user name.
Password	Type the password assigned to you.
Update Period	Enter the number of minutes that pass before the V300 checks to see whether the public IP address on the DDNS matches the device's current IP address. If not, the V300 updates itself.
Apply	Click this to save your changes.
Reset	Click this to set every field in this screen to its last-saved value.

13.6 Clock Alarm Setting

Click **Maintenance > System > Clock Alarm Setting**. The screen appears as shown. Use this screen to configure the V300's clock alarm schedule.

Note: The three alarms must have different configurations. You cannot have two or three identical alarms.

Figure 104 Maintenance > System > Clock Alarm Setting

The following table describes the labels in this screen.

Table 42 Maintenance > System > Clock Alarm Setting

LABEL	DESCRIPTION
Clock Alarm Setting	Select one of three available clock alarms to configure.
Active	Check this to enable the currently selected clock alarm.
Ring Type	Choose a ring type for the currently selected clock alarm. There are 12 available clock alarm ring types.
Day	Choose a day (or number of days) on which the clock alarm will be triggered.
Time of Day (24-Hour Format)	Enter the time of day for the clock alarm to be triggered.
Message	Enter the text message that appears on screen when the clock alarm is triggered. You can enter up to 14 alphanumeric characters (a-z, A-Z, 0-9) and spaces are not allowed.
Apply	Click this to save your changes.
Reset	Click this to set every field in this screen to its last-saved value.

14.1 Overview

This chapter contains information on viewing your V300's logs.

14.2 Logs Screen

Click **Maintenance > Logs** to open the **Logs** screen.

You can view logs and alert messages in this screen. Once the log table is full, old logs are deleted as new logs are created.

Click a column heading to sort the entries. A triangle indicates the direction of the sort order.

Figure 105 Maintenance > Logs

#	Time	Message	Source	Destination	Note
1	Fri Oct 24 10:21:50 2008	SIP Registration Success by SIP: [1001]			ACCOUNT INFO
2	Fri Oct 24 10:21:20 2008	SIP Registration Success by SIP: [1001]			ACCOUNT INFO
3	Fri Oct 24 10:20:50 2008	SIP Registration Success by SIP: [1001]			ACCOUNT INFO
4	Fri Oct 24 10:20:19 2008	SIP Registration Success by SIP: [1001]			ACCOUNT INFO
5	Fri Oct 24 10:19:49 2008	SIP Registration Success by SIP: [1001]			ACCOUNT INFO
6	Fri Oct 24 10:19:19 2008	SIP Registration Success by SIP: [1001]			ACCOUNT INFO
7	Fri Oct 24 10:18:49 2008	SIP Registration Success by SIP: [1001]			ACCOUNT INFO
8	Fri Oct 24 10:18:19 2008	SIP Registration Success by SIP: [1001]			ACCOUNT INFO
9	Fri Oct 24 10:17:55 2008	Web login	172.23.37.35	172.23.37.22	
10	Fri Oct 24 10:17:49 2008	SIP Registration Success by SIP: [1001]			ACCOUNT INFO
11	Fri Oct 24 10:17:31 2008	Web logout	172.23.37.35	172.23.37.22	

The following table describes the labels in this screen.

Table 43 Maintenance > Logs

LABEL	DESCRIPTION
Logs	
Display	Select a category of logs to view.
Refresh	Click Refresh to renew the log screen.
Clear Log	Click Clear Log to delete all the logs.

Table 43 Maintenance > Logs (continued)

LABEL	DESCRIPTION
#	This is the log's index number.
Time	This field displays the time the log was recorded.
Message	This field states the reason for the log.
Source	This field lists the source IP address and the port number of the incoming packet that caused the log, if applicable.
Destination	This field lists the destination IP address and the port number of the outgoing packet that caused the log, if applicable.
Note	This field displays additional information about the log entry.

14.3 SIP Message

Click **Maintenance > Logs > SIP Message** to open this screen.

You can view SIP server messages and responses in this screen. Once the log is full, old messages are deleted as new ones are created.

Figure 106 Maintenance > SIP Message

The following table describes the labels in this screen.

Table 44 Maintenance > SIP Message

LABEL	DESCRIPTION
Refresh	Click this to refresh the V300 SIP messages.
Clear Message	Click this to clear all existing SIP messages in the V300.

15.1 Overview

This chapter shows you how to upload new firmware, upload or save backup configuration files and restart the V300.

15.1.1 What You Can Do in This Chapter

- The **Firmware** screen lets you upload new firmware to your V300 whenever an update becomes available ([Section 15.2 on page 147](#)).
- The **Configuration** screen lets you backup and restore previous configuration settings or the factory defaults ([Section 15.3 on page 150](#)).
- The **Restart** screen lets you restart the V300 ([Section 15.4 on page 152](#)).
- The **Ring Maintenance** screen allows you to upload files to the V300 and use them as ringtones ([Section 15.5 on page 153](#)).
- The **Packet Mirror** screen allows you to send data packets from the V300 to another IP address, where they can be analyzed to clarify Internet-related issues ([Section 15.6 on page 154](#)).

15.2 Firmware Screen

Find firmware at www.zyxel.com in a file that (usually) uses the system model name with a "*.bin" extension, e.g., "V300.bin". The upload process uses HTTP (Hypertext Transfer Protocol) and may take up to two minutes. After a successful upload, the system will reboot. See the Firmware and Configuration File Maintenance chapter for upgrading firmware using FTP/TFTP commands.

Click **Maintenance > Tools**. Follow the instructions in this screen to upload firmware to your V300.

Figure 107 Maintenance > Tools > Firmware Upload

The following table describes the labels in this screen.

Table 45 Maintenance > Tools > Firmware Upload

LABEL	DESCRIPTION
Firmware Upgrade	
File Upload	Type in the location of the file you want to upload in this field or click Browse... to find it.
Browse...	Click Browse... to find the .bin file you want to upload. Remember that you must decompress compressed (.zip) files before you can upload them.
Upload	Click Upload to begin the upload process. This process may take up to two minutes.

Note: Do not turn off the V300 while firmware upload is in progress!

After you see the **Firmware Upload In Process** screen, wait two minutes before logging into the V300 again.

Figure 108 Upload Warning



The V300 automatically restarts during this interval, causing a temporary network disconnect. In some operating systems, you may see the following icon on your desktop.

Figure 109 Network Temporarily Disconnected



After two minutes, log in again and check your new firmware version in the **Status** screen.

If the upload was not successful, the following screen will appear. Click **Return** to go back to the **Firmware** screen.

Figure 110 Upload Error Message



15.3 Configuration Screen

Click **Maintenance > Tools > Configuration**. Information related to factory defaults, backup configuration, and restoring configuration appears on this screen.

Figure 111 Maintenance > Tools > Configuration

The screenshot shows a web interface with four main sections:

- Backup Configuration:** Contains the instruction "Click **Backup** to save the current configuration of your system to your computer." and a "Backup" button.
- Restore Configuration:** Contains the instruction "To restore a previously saved **configuration** file to your system, browse to the location of the **configuration** file and click **Upload**." It includes a text input field, a "Browse..." button, and an "Upload" button.
- Save Debug Log:** Contains the instruction "Click **Save** to save the debug log to your computer." and a "Save" button.
- Back to Factory Defaults:** Contains the instruction "Click **Reset** to clear all user-entered configuration information and return to factory defaults. After resetting, the" followed by a list:
 - Password will be 1234
 - Management Port IP address will be 192.168.5.1
 - Default Ethernet setting will be "Get IP address automatically"
 and a "Reset" button.

15.3.1 Backup Configuration

Backup configuration allows you to back up (save) the V300's current configuration to a file on your computer. Once your V300 is configured and functioning properly, it is highly recommended that you back up your configuration file before making configuration changes. The backup configuration file will be useful in case you need to return to your previous settings.

Click **Backup** to save the V300's current configuration to your computer.

15.3.2 Restore Configuration

Restore configuration allows you to upload a new or previously saved configuration file from your computer to your V300.

Table 46 Maintenance > Tools > Configuration > Restore

LABEL	DESCRIPTION
Restore Configuration	
File Path	Type in the location of the file you want to upload in this field or click Browse... to find it.

Table 46 Maintenance > Tools > Configuration > Restore

LABEL	DESCRIPTION
Browse...	Click Browse... to find the file you want to upload. Remember that you must decompress compressed (.ZIP) files before you can upload them.
Upload	Click Upload to begin the upload process.

Note: Do not turn off the V300 while configuration file upload is in progress

After you see a “configuration upload successful” screen, you must then wait one minute before logging into the V300 again.

Figure 112 Configuration Upload Successful

The V300 automatically restarts during this interval, causing a temporary network disconnect. In some operating systems, you may see the following icon on your desktop.

Figure 113 Temporarily Disconnected

If you uploaded a configuration file that sets the V300 to get an IP address automatically, use the **System Info** LCD menu to find out its new address. See [Section 5.5 on page 55](#) for more information.

If the upload was not successful, the following screen will appear. Click **Return** to go back to the **Configuration** screen.

Figure 114 Configuration Restore Error



15.3.3 Save Debug Log

Save Debug Log allows you save a copy of the V300's debug log to your computer. This is useful if you encounter any problems with the device and need to talk to customer support.

15.3.4 Back to Factory Defaults

Back to Factory Defaults let you clear all user-entered configuration information and returns the V300 to its factory defaults.

You can also press the **RESET** button on the rear panel to reset the factory defaults of your V300. Refer to the chapter about introducing the web configurator for more information on the **RESET** button.

15.4 Restart Screen

System restart allows you to reboot the V300 without turning the power off.

Click **Maintenance > Tools > Restart**. Click **Restart** to have the V300 reboot. This does not affect the V300's configuration.

Figure 115 Maintenance > Tools > Restart

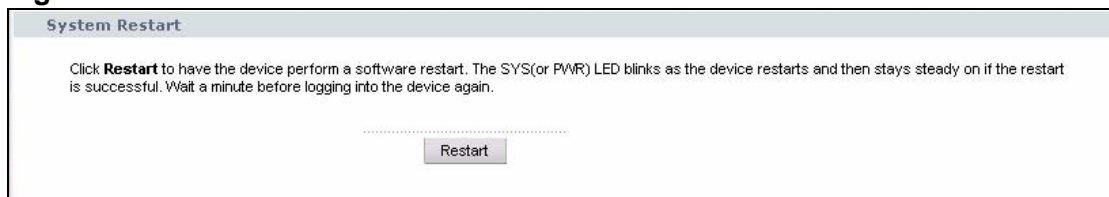

15.5 Ring Maintenance Screen

This screen allows you to upload files to the V300 and use them as ringtones. These files must be MIDI (Musical Instrument Digital Interface) files with a “.midi” extension. You can also download files from the V300 to your computer.

Note: The V300 has ten MIDI file slots. If you upload a MIDI file to a file slot on the V300, the MIDI file already in the slot is deleted. There is no way to retrieve the deleted file, unless it is a default ringtone (in which case you need to reset the V300).

Note: Each MIDI file can be up to 10K in size.

Click **Maintenance > Tools > Ring Maintenance**. The following screen displays.

Figure 116 Maintenance > Tools > Ring Maintenance

The screenshot shows a web interface for 'Ring Maintenance'. At the top, it says 'Click Select midi files.' Below that is a dropdown menu labeled 'Ring Midi File Select:' with the number '1' selected. Underneath is a text input field, a 'Browse...' button (with '(Select A Local File)' text), and an 'Upload' button. The second section is titled 'Ring Download' and contains a 'Download' button.

The following table describes the labels in this screen.

Table 47 Maintenance > Tools > Ring Maintenance

LABEL	DESCRIPTION
Ring Maintenance	
Ring Midi File Select	Select the file you want to manage. The V300 has four MIDI file slots.
Browse	Use this to select the file you want to upload to the V300.
Upload	Click this once you have selected a file you want to upload.
Delete	Click this to delete the file in the slot you selected in the Ring Midi File Select list.
Ring Download	
Download	Click this to download the MIDI file you selected in the Ring Midi File Select list to your computer. The file is saved in .rar format.

15.6 Packet Mirror Screen

This screen is where you can configure packet mirroring on the V300. This sets the device to send voice packets from the V300 to another IP address, where they can be analyzed to clarify Internet-related issues.

Figure 117 Packet Mirror Example

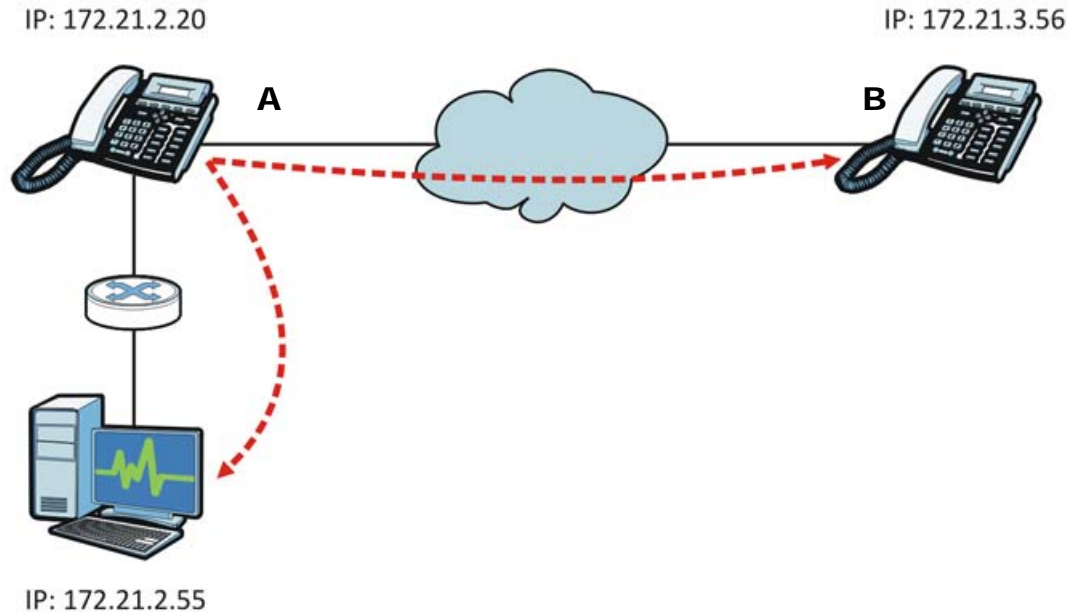

In this example, phone **A** sends its voice packets to phone **B** as part of its routine communication but also sends duplicate packets to a computer with a packet analyzer so that they can be scanned for errors. Furthermore, in order for this to work both phone **A** and the monitoring computer are in the same subnet.

Click **Maintenance > Tools > Packet Mirror**. The following screen displays.

Figure 118 Maintenance > Tools > Packet Mirror

Packet Mirror

Active

MIRROR IP:

The following table describes the labels in this screen.

Table 48 Maintenance > Tools > Ring Maintenance

LABEL	DESCRIPTION
Active	Check this to enable packet mirroring.
Mirror IP	Enter an IP address to which mirrored packets are sent. The mirror IP and the V300's IP must be in the same subnet. For more information subnetting, see Appendix D on page 209 .
Apply	Click this to save your changes.
Reset	Click this to set every field in this screen to its last-saved value.

Troubleshooting

16.1 Overview

This chapter offers some suggestions to solve problems you might encounter. The potential problems are divided into the following categories.

- [Power, Hardware Connections, and LEDs](#)
- [Internet Access](#)
- [Phone Calls and VoIP](#)

16.2 Power, Hardware Connections, and LEDs

The V300 does not turn on. None of the LEDs turn on.

- 1 Make sure you are using the power adaptor or cord included with the V300.
- 2 Make sure the power adaptor or cord is connected to the V300 and plugged in to an appropriate power source. Make sure the power source is turned on.
- 3 Disconnect and re-connect the power adaptor or cord to the V300.
- 4 If the problem continues, contact the vendor.

One of the keys or LEDs does not behave as expected.

- 1 Make sure you understand the normal behavior of the key or LED. See [Section 2.2 on page 32](#).
- 2 Check the hardware connections. See the Quick Start Guide and [Section 2.2 on page 32](#).

- 3 Inspect your cables for damage. Contact the vendor to replace any damaged cables.
- 4 Disconnect and re-connect the power adaptor to the V300.
- 5 If the problem continues, contact the vendor.

I forgot the IP address for the V300.

- 1 The V300 is set to get an IP address automatically by default. Check the IP address in the **System Info > IP Address > IP Address** LCD menu.
- 2 Set a static IP address for the V300 in the **Adv Setting > Network > Static IP** menus (see [Section 6.6 on page 71](#)).
- 3 Alternatively, use the management IP address to log in to the V300 (see [Section 9.3 on page 100](#)).

I forgot the password.

- 1 The default password is **1234**.
- 2 If this does not work, you have to reset the device to its factory defaults. See [Section 2.2.2 on page 37](#).

I cannot see or access the Login screen in the web configurator.

- 1 Make sure you are using the correct IP address.
 - The V300 is set to get an IP address automatically by default. Check the IP address it is using in the **System Info > IP Address > IP Address** LCD menu.
 - If you changed the IP address ([Section on page 97](#)), use the new IP address.
 - If you changed the IP address and have forgotten it, see the troubleshooting suggestions for [I forgot the IP address for the V300](#).
- 2 Check the hardware connections, and make sure the LEDs and the LCD screen are behaving as expected. See the Quick Start Guide and [Section 2.2 on page 32](#).

- 3 Make sure your Internet browser does not block pop-up windows and has JavaScripts and Java enabled. See [Appendix C on page 201](#).
- 4 Make sure your computer is in the same subnet as the V300. (If you know that there are routers between your computer and the V300, skip this step.)
 - If there is no DHCP server on your network, make sure your computer's IP address is in the same subnet as the V300. See [Appendix B on page 171](#).
- 5 If the problem continues, contact the network administrator or vendor, or try one of the advanced suggestions.

Advanced Suggestions

- Try to access the V300 using another service, such as Telnet.

I can see the **Login** screen, but I cannot log in to the V300.

- 1 Make sure you have entered the user name and password correctly. The default password is **1234**. This field is case-sensitive, so make sure [Caps Lock] is not on.
- 2 You cannot log in to the web configurator while someone is using Telnet to access the V300. Log out of the V300 in the other session, or ask the person who is logged in to log out.
- 3 Disconnect and re-connect the power adaptor or cord to the V300.
- 4 If this does not work, you have to reset the device to its factory defaults. See [Section 2.2.2 on page 37](#).

I cannot Telnet to the V300.

See the troubleshooting suggestions for [I cannot see or access the Login screen in the web configurator](#). Ignore the suggestions about your browser.

I cannot use FTP to upload / download the configuration file. / I cannot use FTP to upload new firmware.

See the troubleshooting suggestions for [I cannot see or access the Login screen in the web configurator](#). Ignore the suggestions about your browser.

16.3 Internet Access

I cannot access the Internet through the V300.

- 1 Check the hardware connections, and make sure the LEDs and the LCD screen are behaving as expected. See the Quick Start Guide and [Section 2.2 on page 32](#).
- 2 Disconnect all the cables from your device, and follow the directions in the Quick Start Guide again.
- 3 If the problem continues, contact your ISP.

I cannot access the Internet anymore. I had access to the Internet (with the V300), but my Internet connection is not available anymore.

- 1 Check the hardware connections, and make sure the LEDs and the LCD screen are behaving as expected. See the Quick Start Guide and [Section 2.2 on page 32](#).
- 2 Restart the V300.
- 3 If the problem continues, contact your ISP.

The Internet connection is slow or intermittent.

- 1 There might be a lot of traffic on the network. Check [Section 2.2 on page 32](#). If the V300 is sending or receiving a lot of information, try closing some programs that use the Internet, especially peer-to-peer applications.
- 2 Check the signal strength. If the signal strength is low, try moving the V300 closer to the AP if possible, and look around to see if there are any devices that might be interfering with the wireless network (for example, microwaves, other wireless networks, and so on).
- 3 Reboot the V300.
- 4 If the problem continues, contact the network administrator or vendor, or try one of the advanced suggestions.

16.4 Phone Calls and VoIP

I cannot make VoIP calls.

Ensure that your V300 is set up as shown in your Quick Start Guide and [Section 2.2 on page 32](#).

Look at the LCD screen. If a SIP account is registered, its name appears here. If a SIP account is not registered, **No Reg** displays.

If no SIP account is registered, do the following.

- 1 The V300's SIP settings may be misconfigured. Check your SIP settings and re-enter them if necessary (see [Section 6.3 on page 60](#) for details).
- 2 If **No Reg** still displays, check your network settings (see [Section 5.5 on page 55](#)). If they are not correct, change them using information supplied by your ISP or network administrator. If this does not help, contact your ISP or network administrator.

If a SIP account is registered, try to make the call. If you still cannot call out, do the following.

- 1 Check your DNS (Domain Name Service) settings (see [Section 5.5 on page 55](#)).
 - If you use a static IP address, see [Section 6.6 on page 71](#) for how to change DNS settings.
 - If you use a dynamic IP address (DHCP) your DNS settings are controlled by the DHCP server. The DHCP server may belong to your service provider, or it may be on your network. If your V300 does not get DNS server information automatically, check the settings on any hardware to which the V300 is connected, or contact your ISP or network administrator.
 - If you use PPPoE, your DNS settings are controlled by your Internet Service Provider. If your V300 does not get DNS server information automatically, contact your ISP.
- 2 Make sure that your V300 uses the voice codecs recommended by your VoIP service provider (see [Section 6.5 on page 71](#)).

I can make some VoIP calls, but not others.

The V300's DNS (Domain Name Service) settings may be misconfigured. See the suggestions about DNS in the troubleshooting section for "[I cannot make VoIP calls.](#)".

If this does not help, the phone of the person you are calling may be malfunctioning or misconfigured.

[I can make phonecalls, but I cannot receive them.](#)
or
[I can receive some phonecalls, but not others.](#)

Check your V300's call forwarding settings in the **VoIP > Phone Book > Call Forward** screen (see [Section 12.2 on page 127](#)). If they are misconfigured, certain calls may be mistakenly forwarded.

[All my VoIP calls are of poor audio quality.](#)

- If your ISP or network administrator gave you SIP TOS or RTP TOS values to use, enter them in the web configurator's **VoIP > SIP > QoS** screen (see [Section 10.3 on page 117](#)).
- If your V300 is connected to a router with configurable bandwidth management settings, check these settings. Consult the router's documentation for more information.
- Make sure that your V300 uses the voice codecs recommended by your VoIP service provider (see [Section 6.5 on page 71](#)).

[I cannot use some calling features.](#)

Many of the features your V300 supports depend on your VoIP service provider. You may have to subscribe to certain services. Contact your VoIP service provider for more information.

[The incoming or outgoing audio is too quiet or too loud.](#)
or
[I cannot hear the V300's ring when a call is incoming.](#)

Use the **VOLUME** keys to increase or decrease the volume.

- When no audio device (the handset, speakerphone or an external headset) is active, the **VOLUME** keys control the ringing volume.
- When an audio device is active, the **VOLUME** keys control the input and output of that device.

Product Specifications

The following tables summarize the V300's hardware and firmware features.

Table 49 Hardware Specifications

Dimensions (W x D x H)	16.5mm x 208mm x 91.5mm
Weight	465g
Power Specification	12V DC, 1.5A
Power over Ethernet (PoE) - V301 Only	IEEE 802.3af compliant.
Ethernet Ports	Auto-negotiating: 10 Mbps or 100 Mbps in either half-duplex or full-duplex mode. Use crossover Ethernet cables.
Handset Port	RJ-11 telephone connector.
(Headset) Microphone Port	3.5mm
(Headset) Headphone Port	3.5mm
Operation Temperature	0 ~ 40 C
Storage Temperature	-30 ~ 60 C
Operation Humidity	20 ~ 95% RH
Storage Humidity	20 ~ 95% RH
Distance between the centers of the holes (for wall mounting) on the device's back.	100mm
Recommended type of screws for wall-mounting	M4 Tap Screw, see Figure 120 on page 169 .

Table 49 Hardware Specifications

Speakerphone	Internal speaker and microphone.
Phone Functions	<p>Call forwarding</p> <p>Call transferring</p> <p>Conference calling</p> <p>Last number redial</p> <p>Voicemail</p> <p>Call muting</p> <p>Do Not Disturb</p> <p>Phonebook</p>

Table 50 Firmware Specifications

FEATURE	DESCRIPTION
Default DHCP status	Client
Default management IP address	192.168.5.1
Default Password	1234
Device Management	Use the V300's LCD screen menus or the web configurator to easily configure the rich range of features.
Firmware Upgrade	<p>Download new firmware (when available) from the ZyXEL web site and use the web configurator, an FTP or a TFTP tool to put it on the V300.</p> <p>Note: Only upload firmware for your specific model!</p>
Configuration Backup & Restoration	Make a copy of the V300's configuration. You can put it back on the V300 later if you decide to revert back to an earlier configuration.
Network Address Translation (NAT)	Each computer on your network must have its own unique IP address. Use NAT to convert your public IP address(es) to multiple private IP addresses for the computers on your network.
Time and Date	Get the current time and date from an external server when you turn on your V300. You can also set the time manually. These dates and times are then used in logs.
Logging and Tracing	Use packet tracing and logs for troubleshooting. You can send logs from the V300 to an external syslog server.
PPPoE	PPPoE mimics a dial-up Internet access connection.
Remote Management	This allows you to decide whether a service (HTTP or FTP traffic for example) from a computer on a network (LAN or WAN for example) can access the V300.
Embedded FTP and TFTP Servers	The embedded FTP and TFTP servers enable fast firmware upgrades as well as configuration file backups and restoration.

Table 50 Firmware Specifications

FEATURE	DESCRIPTION
Auto-provisioning support	When auto-provisioning is used, the V300 downloads its settings automatically from the auto-provisioning server, meaning you do not have to input them manually.
Dynamic Jitter Buffer	The built-in adaptive buffer helps to smooth out the variations in delay (jitter) for voice traffic. This helps ensure good voice quality for your conversations.
Voice Activity Detection/ Silence Suppression	Voice Activity Detection (VAD) reduces the bandwidth that a call uses by not transmitting when you are not speaking.
Comfort Noise Generation	Your device generates background noise to fill moments of silence when the other device in a call stops transmitting because the other party is not speaking (as total silence could easily be mistaken for a lost connection).
Echo Cancellation	Your device supports G.167, an ITU-T standard for eliminating the echo caused by the sound of your voice reverberating in the telephone receiver while you talk.
QoS (Quality of Service)	Quality of Service (QoS) mechanisms help to provide better service on a per-flow basis. Your device supports Type of Service (ToS) tagging. This allows the device to tag voice frames so they can be prioritized over the network.
Voice Codecs	G.711a/u, G.723.1A, G.726 (16/24/32/40), G.729a/b
DTMF	In-band and out-of band PCM, RFC2833, SIP Info

The following list, which is not exhaustive, illustrates the standards supported in the V300.

Table 51 Standards Supported

STANDARD	DESCRIPTION
RFC 1058	RIP-1 (Routing Information Protocol)
RFC 1112	IGMP v1
RFC 1305	Network Time Protocol (NTP version 3)
RFC 1321	The MD5 Message-Digest Algorithm
RFC 1483	Multiprotocol Encapsulation over ATM Adaptation Layer 5
RFC 1631	IP Network Address Translator (NAT)
RFC 1661	The Point-to-Point Protocol (PPP)
RFC 1723	RIP-2 (Routing Information Protocol)
RFC 1890	RTP Profile for Audio and Video Conferences with Minimal Control
RFC 2236	Internet Group Management Protocol, Version 2.
RFC 2327	SDP: Session Description Protocol.
RFC 2408	Internet Security Association and Key Management Protocol (ISAKMP)
RFC 2516	A Method for Transmitting PPP Over Ethernet (PPPoE)

Table 51 Standards Supported (continued)

STANDARD	DESCRIPTION
RFC 2617	HTTP Authentication: Basic and Digest Access Authentication
RFC 2766	Network Address Translation - Protocol
RFC 2782	A DNS RR for specifying the location of services (DNS SRV)
RFC 2833	RTP Payload for DTMF Digits, Telephony Tones and Telephony Signals
RFC 2976	The SIP INFO Method
RFC 3261	SIP: Session Initiation Protocol. (Updated by RFC3265, RFC3853)
RFC 3262	Reliability of Provisional Responses in Session Initiation
RFC 3263	Session Initiation Protocol (SIP): Locating SIP Servers.
RFC 3264	An Offer/Answer Model with Session Description Protocol (SDP)
RFC 3389	Real-time Transport Protocol (RTP) Payload for Comfort Noise (CN)
RFC 3515	The Session Initiation Protocol (SIP) Refer Method.
RFC 3550	RTP: A Transport Protocol for Real-Time Applications.
RFC 3581	An Extension to the Session Initiation Protocol (SIP) for Symmetric Response Routing.
RFC 3608	Session Initiation Protocol (SIP) Extension Header Field for Service Route Discovery During Registration
RFC 3665	Session Initiation Protocol (SIP) Basic Call Flow Examples
RFC 3711	The Secure Real-time Transport Protocol (SRTP)
RFC 3842	A Message Summary and Message Waiting Indication Event Package for the Session Initiation Protocol (SIP)
RFC 3891	The Session Initiation Protocol (SIP) "Replaces" Header
RFC 3892	The Session Initiation Protocol (SIP) Referred-By Mechanism. R.
RFC 4028	Session Timers in the Session Initiation Protocol (SIP)
ITU Q.23	Dual-Tone Multi-Frequency signaling (DTMF)

Wall-mounting Instructions

Complete the following steps to hang your V300 on a wall.

Note: See [Table 49 on page 165](#) for the size of screws to use and how far apart to place them.

- 1 Select a position free of obstructions on a sturdy wall.
- 2 Drill two holes for the screws.

Be careful to avoid damaging pipes or cables located inside the wall when drilling holes for the screws.

- 3 Do not insert the screws all the way into the wall. Leave a small gap of about 0.5 cm between the heads of the screws and the wall.
- 4 Make sure the screws are snugly fastened to the wall. They need to hold the weight of the V300 with the connection cables.
- 5 Align the holes on the back of the V300 with the screws on the wall. Hang the V300 on the screws.

Figure 119 Wall-mounting Example

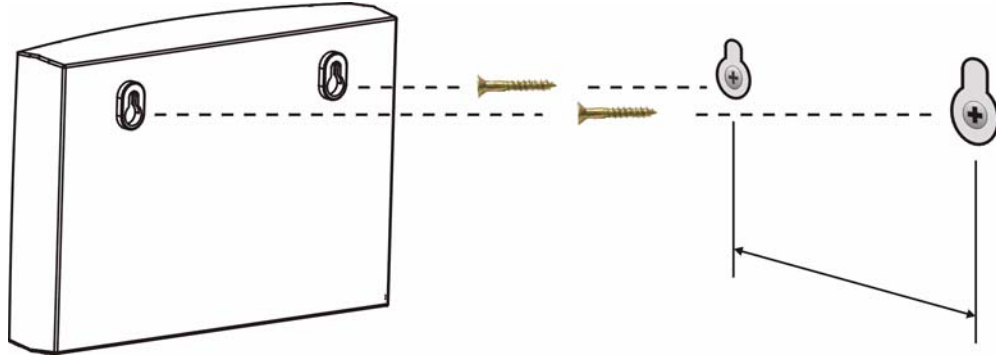

The following are dimensions of an M4 tap screw and masonry plug used for wall mounting. All measurements are in millimeters (mm).

Figure 120 Masonry Plug and M4 Tap Screw

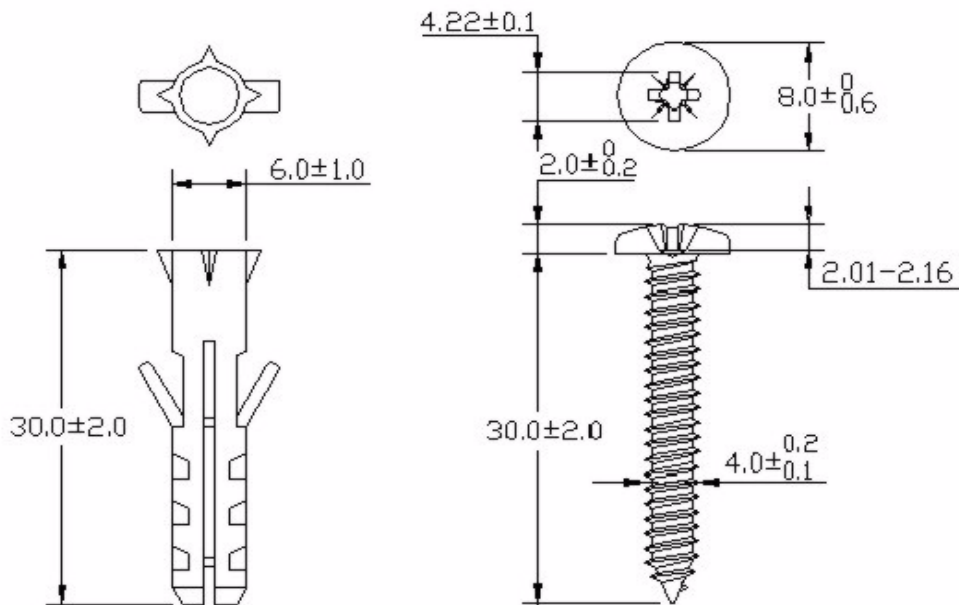

Setting Up Your Computer's IP Address

Note: Your specific ZyXEL device may not support all of the operating systems described in this appendix. See the product specifications for more information about which operating systems are supported.

This appendix shows you how to configure the IP settings on your computer in order for it to be able to communicate with the other devices on your network. Windows Vista/XP/2000, Mac OS 9/OS X, and all versions of UNIX/LINUX include the software components you need to use TCP/IP on your computer.

If you manually assign IP information instead of using a dynamic IP, make sure that your network's computers have IP addresses that place them in the same subnet.

In this appendix, you can set up an IP address for:

- [Windows XP/NT/2000](#) on [page 172](#)
- [Windows Vista](#) on [page 176](#)
- [Mac OS X: 10.3 and 10.4](#) on [page 181](#)
- [Mac OS X: 10.5](#) on [page 185](#)
- [Linux: Ubuntu 8 \(GNOME\)](#) on [page 188](#)
- [Linux: openSUSE 10.3 \(KDE\)](#) on [page 194](#)

Windows XP/NT/2000

The following example uses the default Windows XP display theme but can also apply to Windows 2000 and Windows NT.

- 1 Click **Start > Control Panel**.

Figure 121 Windows XP: Start Menu

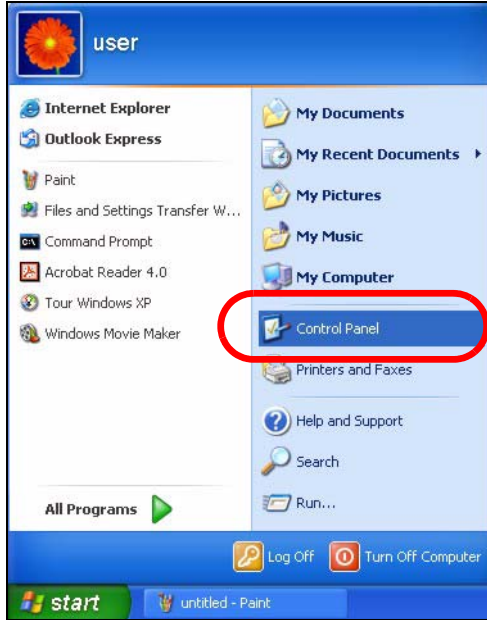

- 2 In the **Control Panel**, click the **Network Connections** icon.

Figure 122 Windows XP: Control Panel



- 3 Right-click **Local Area Connection** and then select **Properties**.

Figure 123 Windows XP: Control Panel > Network Connections > Properties

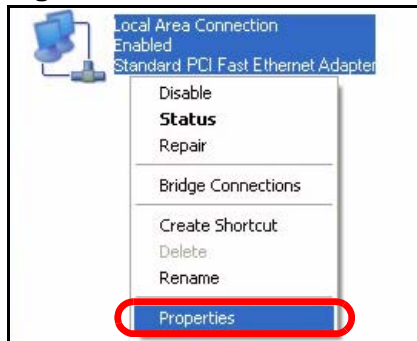

- 4 On the **General** tab, select **Internet Protocol (TCP/IP)** and then click **Properties**.

Figure 124 Windows XP: Local Area Connection Properties

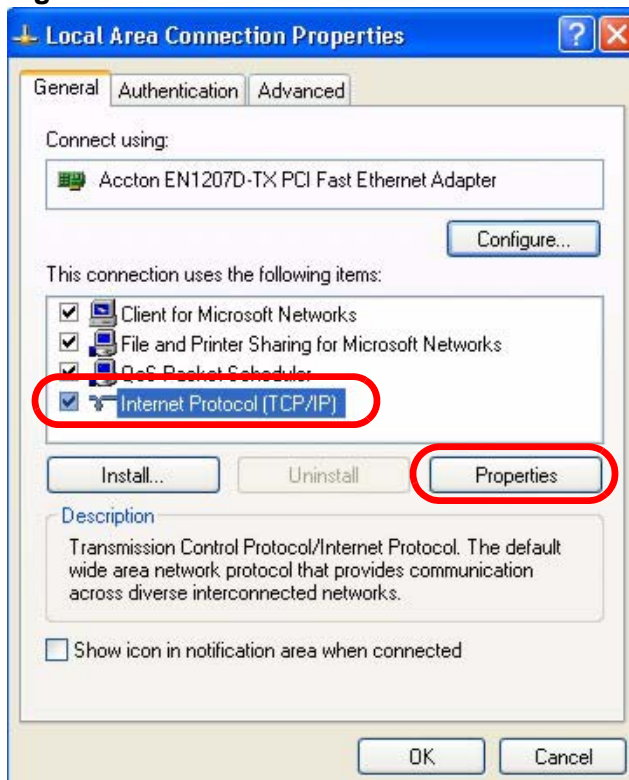

- 5 The **Internet Protocol TCP/IP Properties** window opens.

Figure 125 Windows XP: Internet Protocol (TCP/IP) Properties

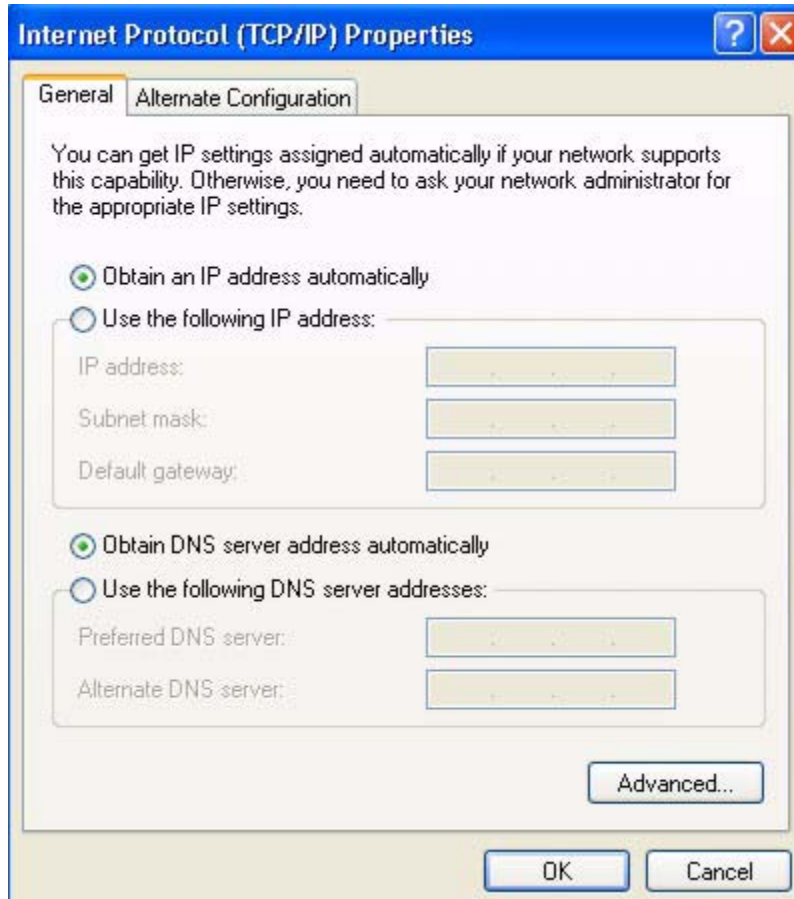

- 6 Select **Obtain an IP address automatically** if your network administrator or ISP assigns your IP address dynamically.

Select **Use the following IP Address** and fill in the **IP address**, **Subnet mask**, and **Default gateway** fields if you have a static IP address that was assigned to you by your network administrator or ISP. You may also have to enter a **Preferred DNS server** and an **Alternate DNS server**, if that information was provided.

- 7 Click **OK** to close the **Internet Protocol (TCP/IP) Properties** window.
- 8 Click **OK** to close the **Local Area Connection Properties** window.

Verifying Settings

- 1 Click **Start > All Programs > Accessories > Command Prompt**.

- 2 In the **Command Prompt** window, type "ipconfig" and then press [ENTER].

You can also go to **Start > Control Panel > Network Connections**, right-click a network connection, click **Status** and then click the **Support** tab to view your IP address and connection information.

Windows Vista

This section shows screens from Windows Vista Professional.

- 1 Click **Start > Control Panel**.

Figure 126 Windows Vista: Start Menu

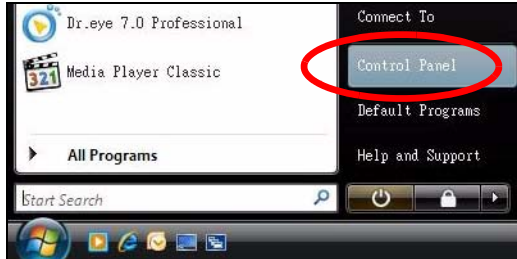

- 2 In the **Control Panel**, click the **Network and Internet** icon.

Figure 127 Windows Vista: Control Panel

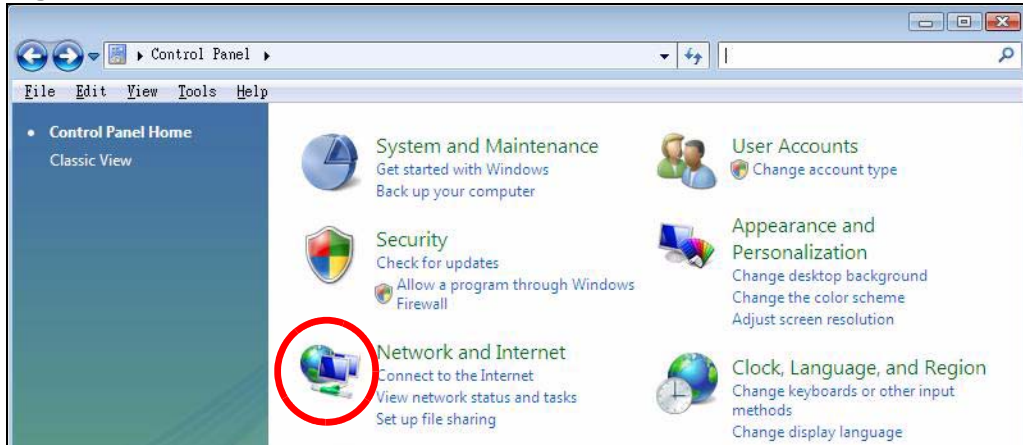

- 3 Click the **Network and Sharing Center** icon.

Figure 128 Windows Vista: Network And Internet

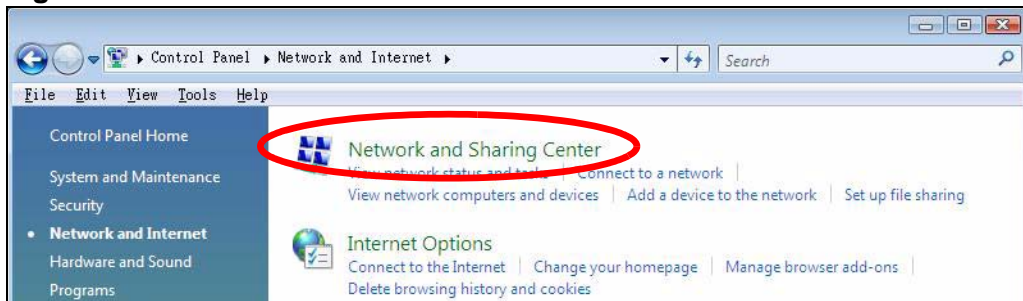

- 4 Click **Manage network connections**.

Figure 129 Windows Vista: Network and Sharing Center

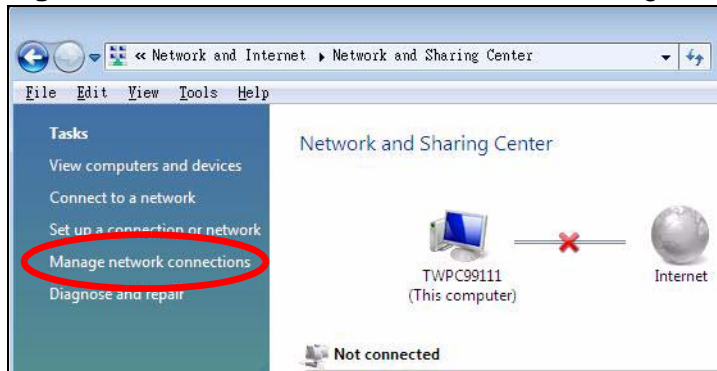

- 5 Right-click **Local Area Connection** and then select **Properties**.

Figure 130 Windows Vista: Network and Sharing Center

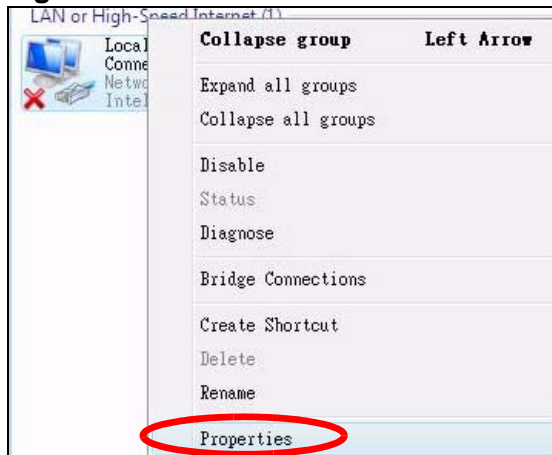

Note: During this procedure, click **Continue** whenever Windows displays a screen saying that it needs your permission to continue.

- 6 Select **Internet Protocol Version 4 (TCP/IPv4)** and then select **Properties**.

Figure 131 Windows Vista: Local Area Connection Properties

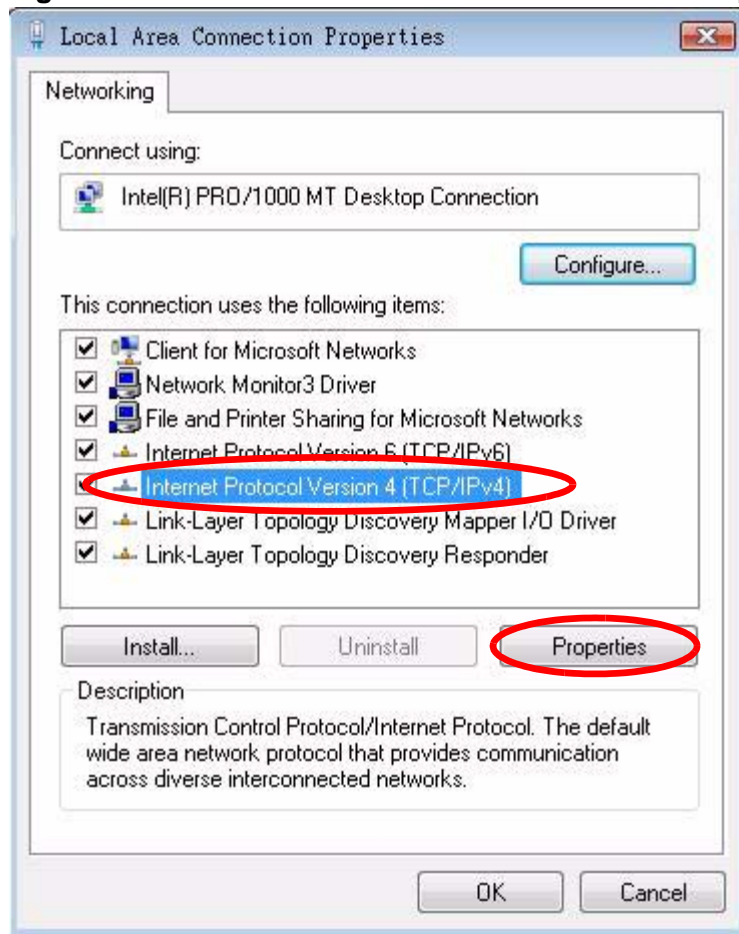

- 7 The **Internet Protocol Version 4 (TCP/IPv4) Properties** window opens.

Figure 132 Windows Vista: Internet Protocol Version 4 (TCP/IPv4) Properties

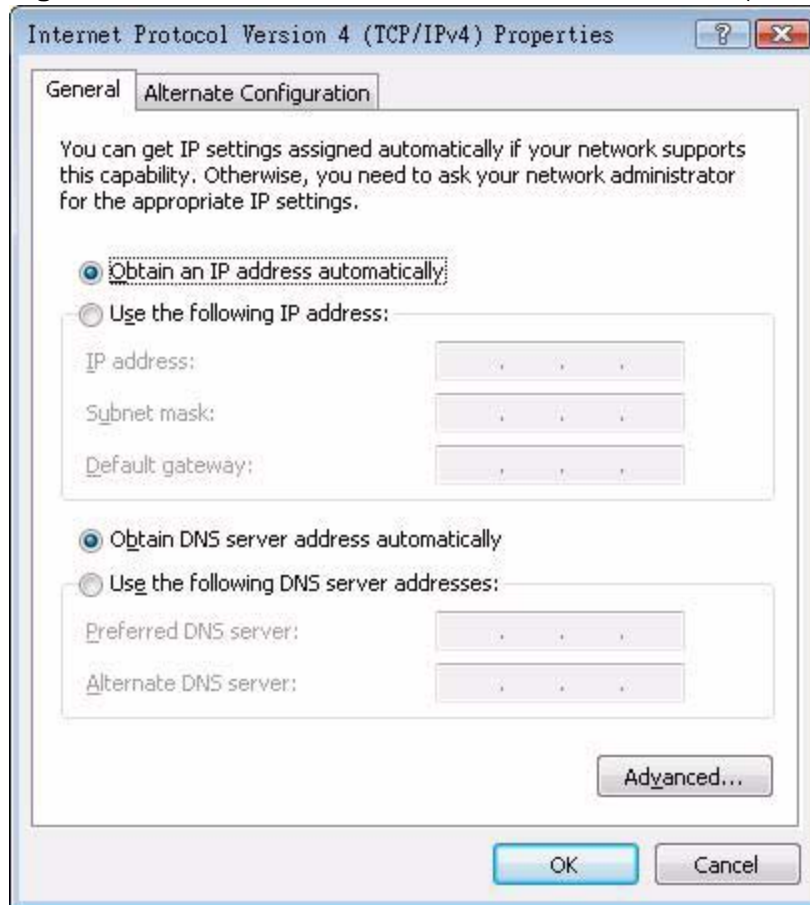

- 8 Select **Obtain an IP address automatically** if your network administrator or ISP assigns your IP address dynamically.

Select **Use the following IP Address** and fill in the **IP address**, **Subnet mask**, and **Default gateway** fields if you have a static IP address that was assigned to you by your network administrator or ISP. You may also have to enter a **Preferred DNS server** and an **Alternate DNS server**, if that information was provided. Click **Advanced**.

- 9 Click **OK** to close the **Internet Protocol (TCP/IP) Properties** window.
- 10 Click **OK** to close the **Local Area Connection Properties** window.

Verifying Settings

- 1 Click **Start > All Programs > Accessories > Command Prompt**.

- 2 In the **Command Prompt** window, type "ipconfig" and then press [ENTER].

You can also go to **Start > Control Panel > Network Connections**, right-click a network connection, click **Status** and then click the **Support** tab to view your IP address and connection information.

Mac OS X: 10.3 and 10.4

The screens in this section are from Mac OS X 10.4 but can also apply to 10.3.

- 1 Click **Apple** > **System Preferences**.

Figure 133 Mac OS X 10.4: Apple Menu

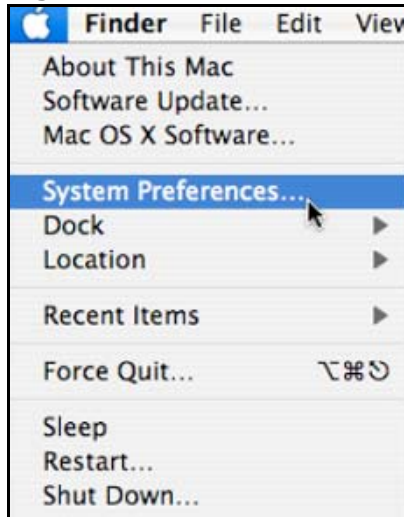

- 2 In the **System Preferences** window, click the **Network** icon.

Figure 134 Mac OS X 10.4: System Preferences



- 3 When the **Network** preferences pane opens, select **Built-in Ethernet** from the network connection type list, and then click **Configure**.

Figure 135 Mac OS X 10.4: Network Preferences

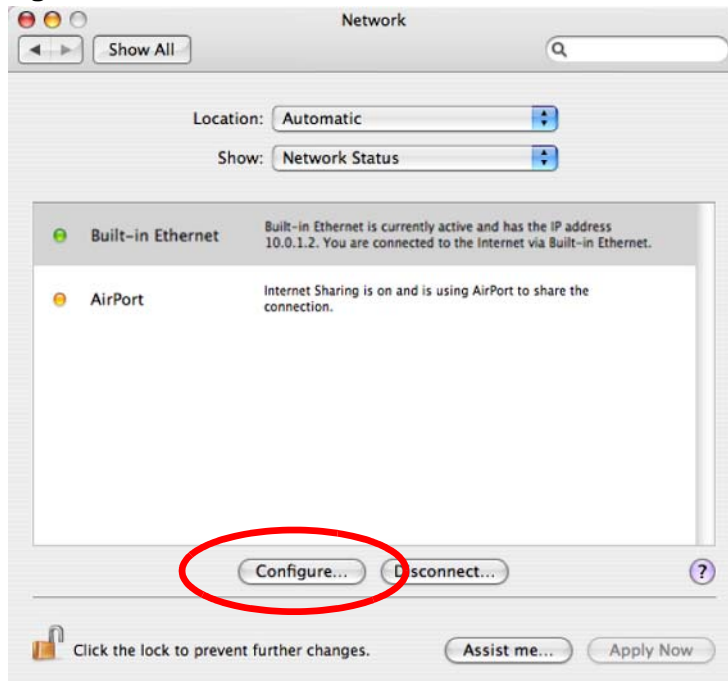

- 4 For dynamically assigned settings, select **Using DHCP** from the **Configure IPv4** list in the **TCP/IP** tab.

Figure 136 Mac OS X 10.4: Network Preferences > TCP/IP Tab.

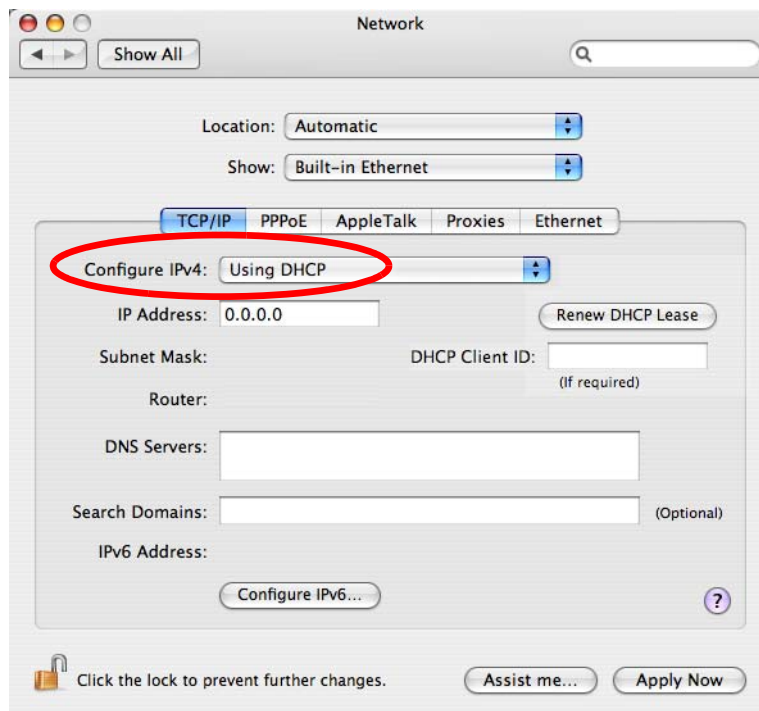

- 5 For statically assigned settings, do the following:
 - From the **Configure IPv4** list, select **Manually**.
 - In the **IP Address** field, type your IP address.
 - In the **Subnet Mask** field, type your subnet mask.
 - In the **Router** field, type the IP address of your device.

Figure 137 Mac OS X 10.4: Network Preferences > Ethernet

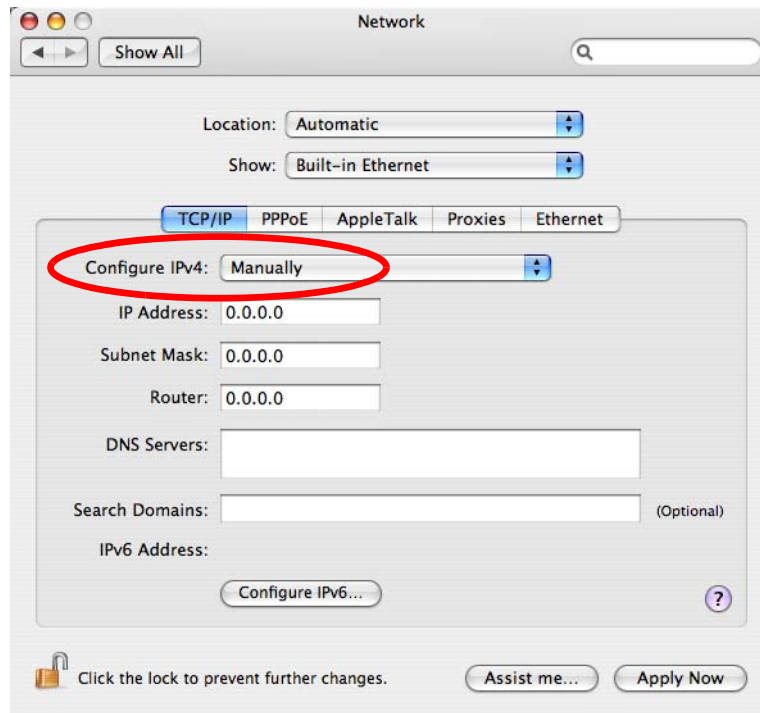

- 6 Click **Apply Now** and close the window.

Verifying Settings

Check your TCP/IP properties by clicking **Applications > Utilities > Network Utilities**, and then selecting the appropriate **Network Interface** from the **Info** tab.

Figure 138 Mac OS X 10.4: Network Utility

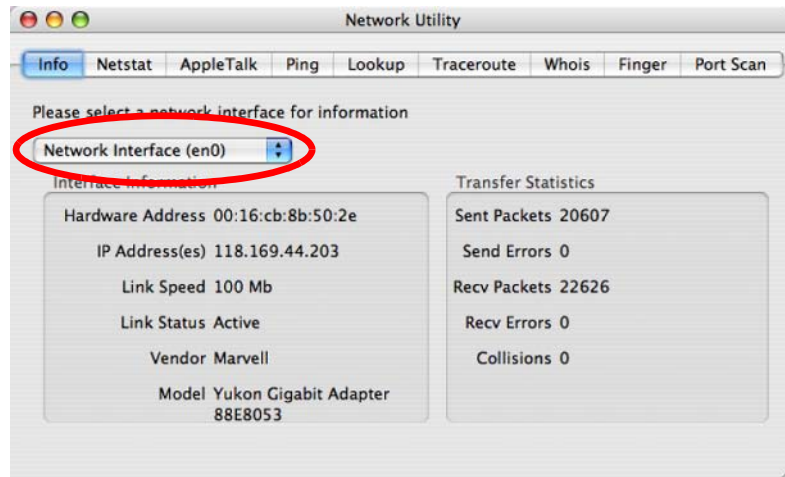

Mac OS X: 10.5

The screens in this section are from Mac OS X 10.5.

- 1 Click **Apple** > **System Preferences**.

Figure 139 Mac OS X 10.5: Apple Menu

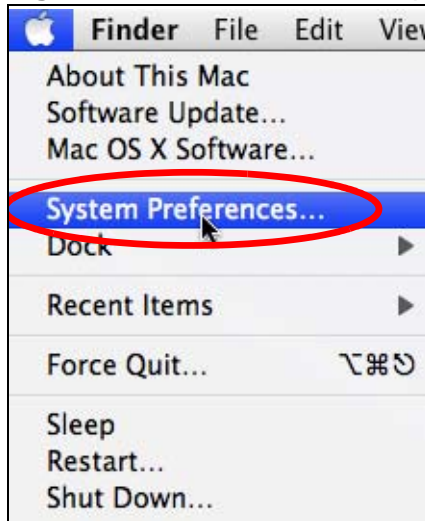

- 2 In **System Preferences**, click the **Network** icon.

Figure 140 Mac OS X 10.5: Systems Preferences



- When the **Network** preferences pane opens, select **Ethernet** from the list of available connection types.

Figure 141 Mac OS X 10.5: Network Preferences > Ethernet

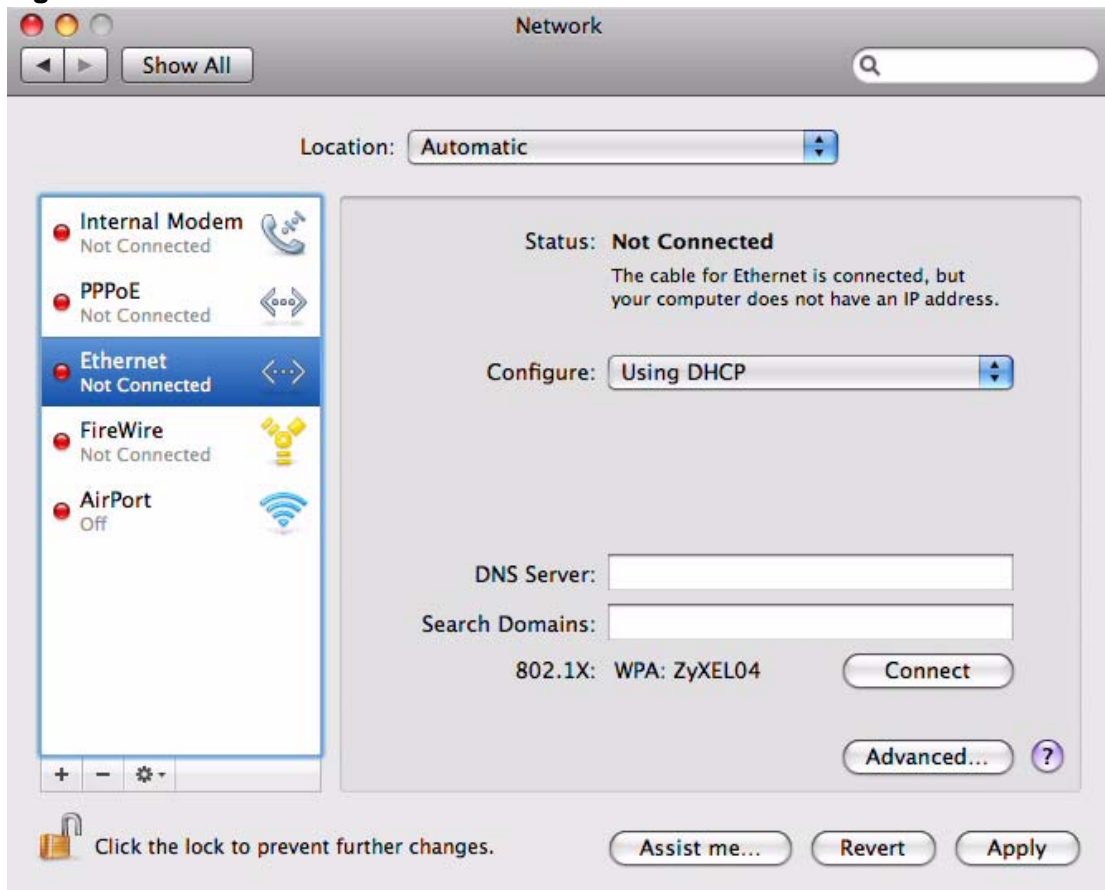

- From the **Configure** list, select **Using DHCP** for dynamically assigned settings.
- For statically assigned settings, do the following:
 - From the **Configure** list, select **Manually**.
 - In the **IP Address** field, enter your IP address.
 - In the **Subnet Mask** field, enter your subnet mask.

- In the **Router** field, enter the IP address of your V300.

Figure 142 Mac OS X 10.5: Network Preferences > Ethernet

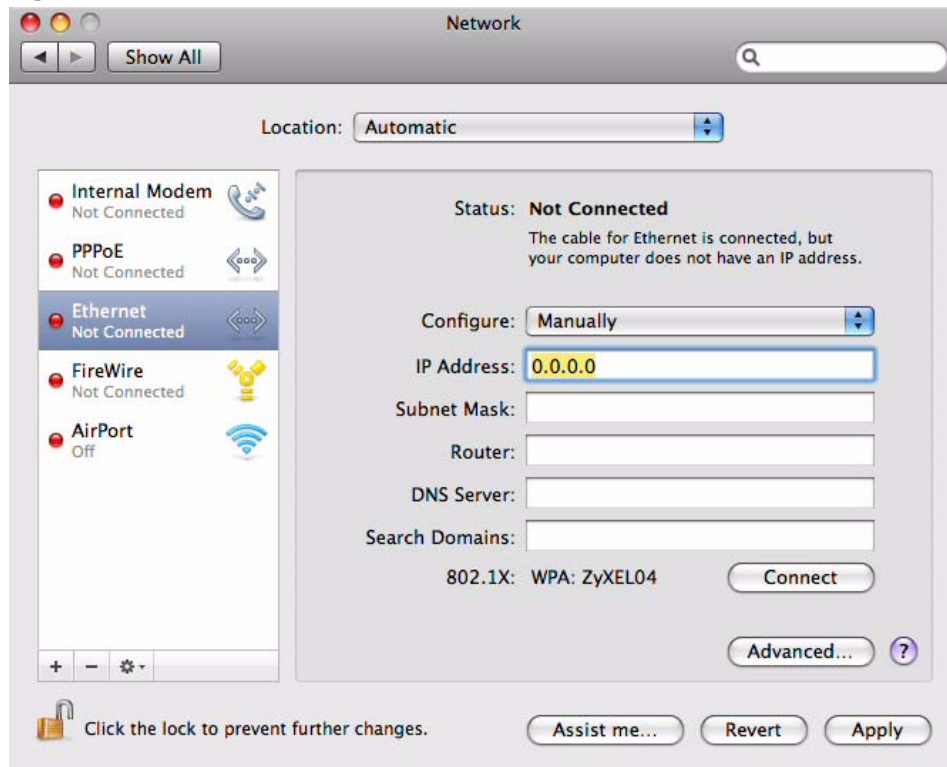

- 6 Click **Apply** and close the window.

Verifying Settings

Check your TCP/IP properties by clicking **Applications > Utilities > Network Utilities**, and then selecting the appropriate **Network interface** from the **Info** tab.

Figure 143 Mac OS X 10.5: Network Utility

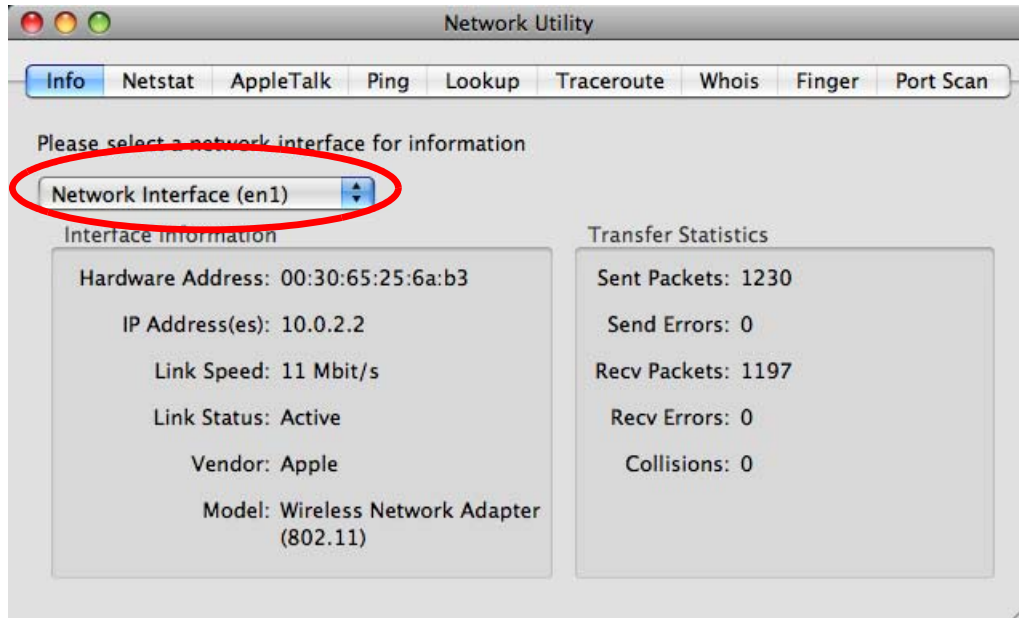

Linux: Ubuntu 8 (GNOME)

This section shows you how to configure your computer's TCP/IP settings in the GNU Object Model Environment (GNOME) using the Ubuntu 8 Linux distribution. The procedure, screens and file locations may vary depending on your specific distribution, release version, and individual configuration. The following screens use the default Ubuntu 8 installation.

Note: Make sure you are logged in as the root administrator.

Follow the steps below to configure your computer IP address in GNOME:

- 1 Click **System > Administration > Network**.

Figure 144 Ubuntu 8: System > Administration Menu

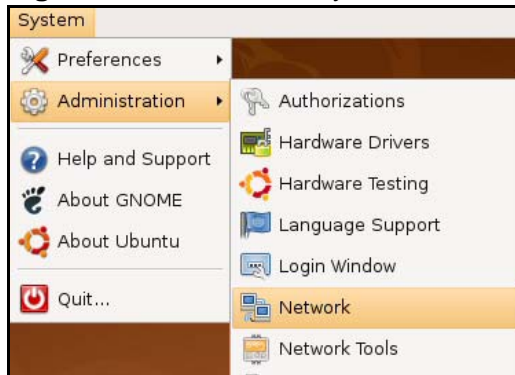

- 2 When the **Network Settings** window opens, click **Unlock** to open the **Authenticate** window. (By default, the **Unlock** button is greyed out until clicked.) You cannot make changes to your configuration unless you first enter your admin password.

Figure 145 Ubuntu 8: Network Settings > Connections

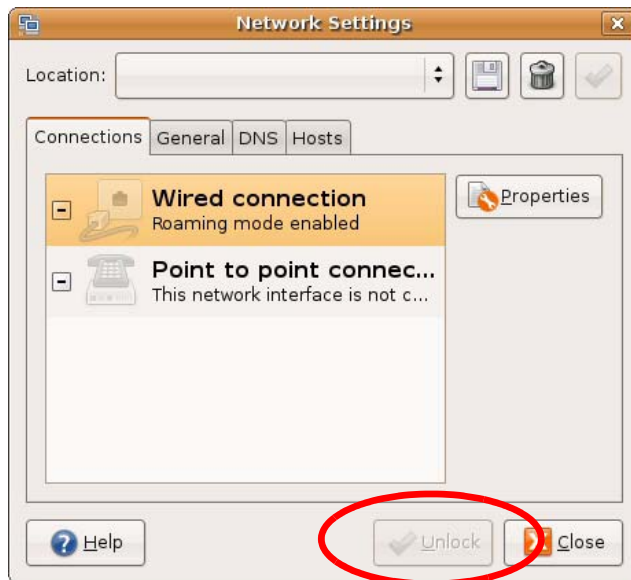

- 3 In the **Authenticate** window, enter your admin account name and password then click the **Authenticate** button.

Figure 146 Ubuntu 8: Administrator Account Authentication



- 4 In the **Network Settings** window, select the connection that you want to configure, then click **Properties**.

Figure 147 Ubuntu 8: Network Settings > Connections



- 5 The **Properties** dialog box opens.

Figure 148 Ubuntu 8: Network Settings > Properties



- In the **Configuration** list, select **Automatic Configuration (DHCP)** if you have a dynamic IP address.
 - In the **Configuration** list, select **Static IP address** if you have a static IP address. Fill in the **IP address**, **Subnet mask**, and **Gateway address** fields.
- 6 Click **OK** to save the changes and close the **Properties** dialog box and return to the **Network Settings** screen.

- 7 If you know your DNS server IP address(es), click the **DNS** tab in the **Network Settings** window and then enter the DNS server information in the fields provided.

Figure 149 Ubuntu 8: Network Settings > DNS



- 8 Click the **Close** button to apply the changes.

Verifying Settings

Check your TCP/IP properties by clicking **System > Administration > Network Tools**, and then selecting the appropriate **Network device** from the **Devices**

tab. The **Interface Statistics** column shows data if your connection is working properly.

Figure 150 Ubuntu 8: Network Tools

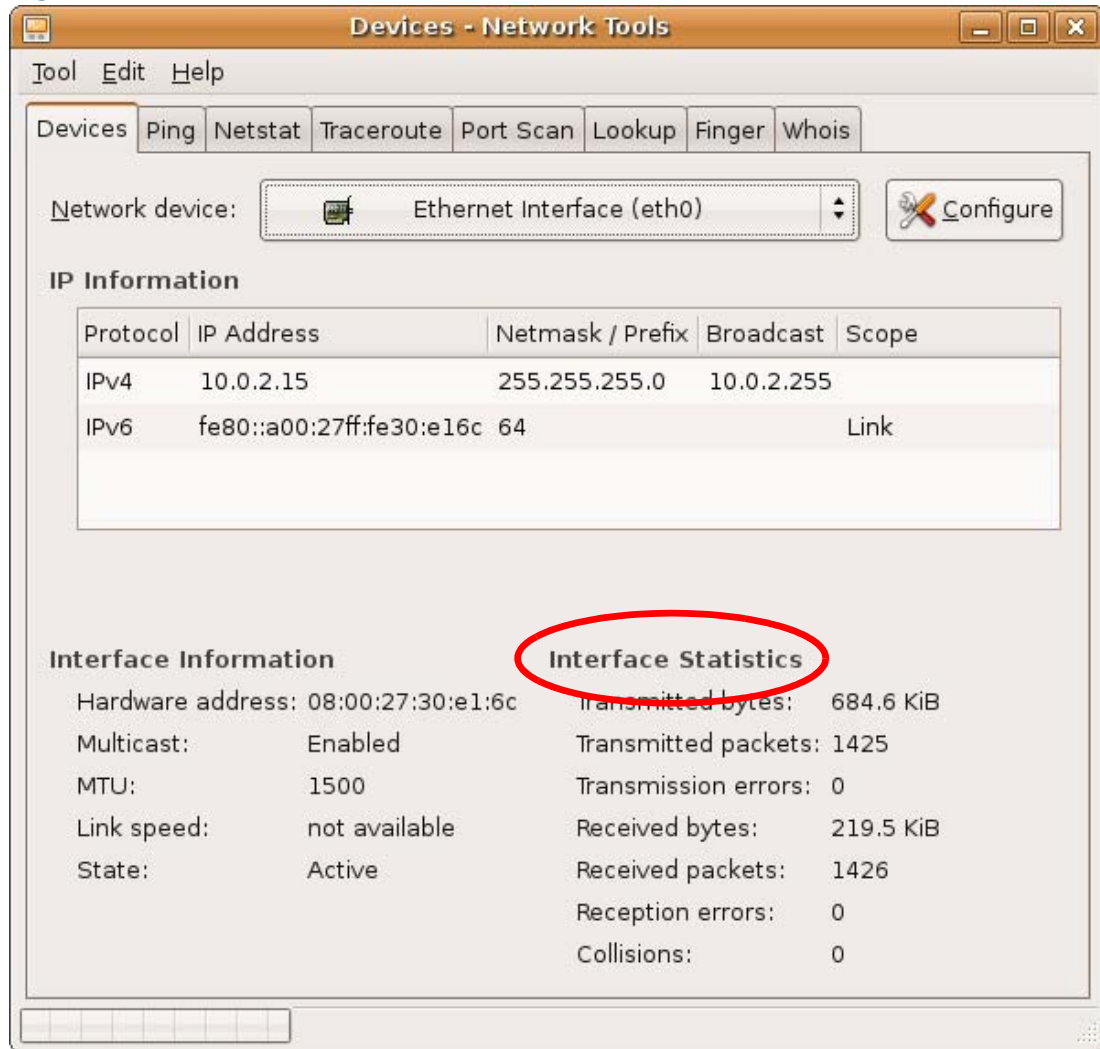

Linux: openSUSE 10.3 (KDE)

This section shows you how to configure your computer's TCP/IP settings in the K Desktop Environment (KDE) using the openSUSE 10.3 Linux distribution. The procedure, screens and file locations may vary depending on your specific distribution, release version, and individual configuration. The following screens use the default openSUSE 10.3 installation.

Note: Make sure you are logged in as the root administrator.

Follow the steps below to configure your computer IP address in the KDE:

- 1 Click **K Menu > Computer > Administrator Settings (YaST)**.

Figure 151 openSUSE 10.3: K Menu > Computer Menu

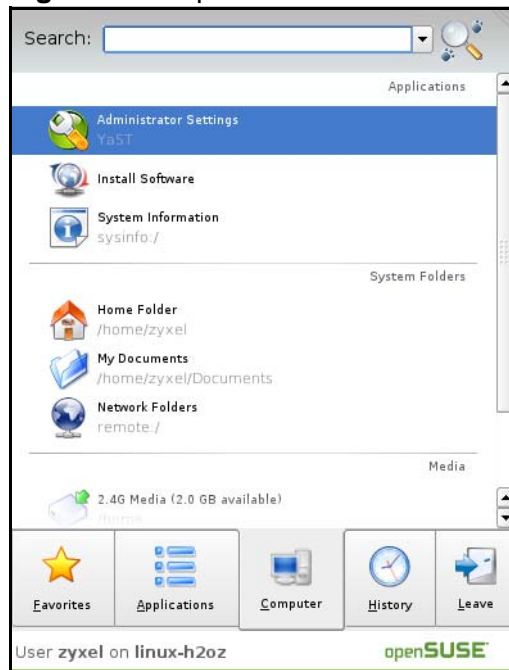

- 2 When the **Run as Root - KDE su** dialog opens, enter the admin password and click **OK**.

Figure 152 openSUSE 10.3: K Menu > Computer Menu

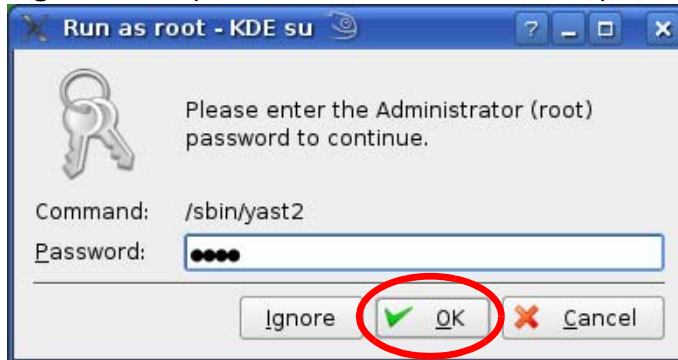

- 3 When the **YaST Control Center** window opens, select **Network Devices** and then click the **Network Card** icon.

Figure 153 openSUSE 10.3: YaST Control Center

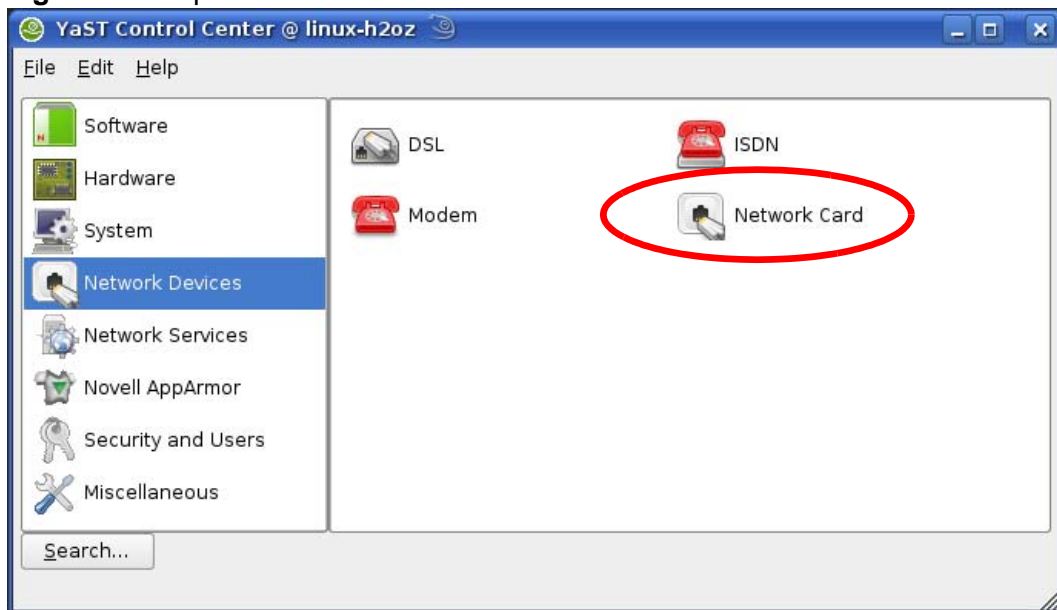

- 4 When the **Network Settings** window opens, click the **Overview** tab, select the appropriate connection **Name** from the list, and then click the **Configure** button.

Figure 154 openSUSE 10.3: Network Settings

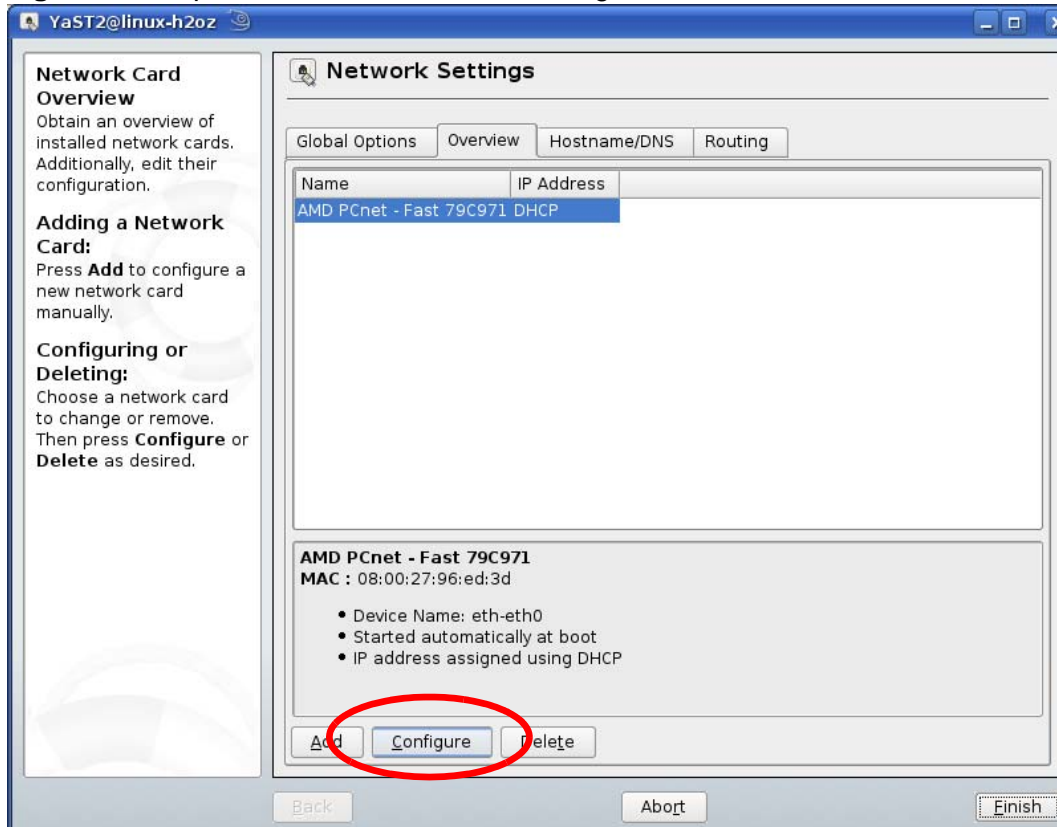

- 5 When the **Network Card Setup** window opens, click the **Address** tab

Figure 155 openSUSE 10.3: Network Card Setup

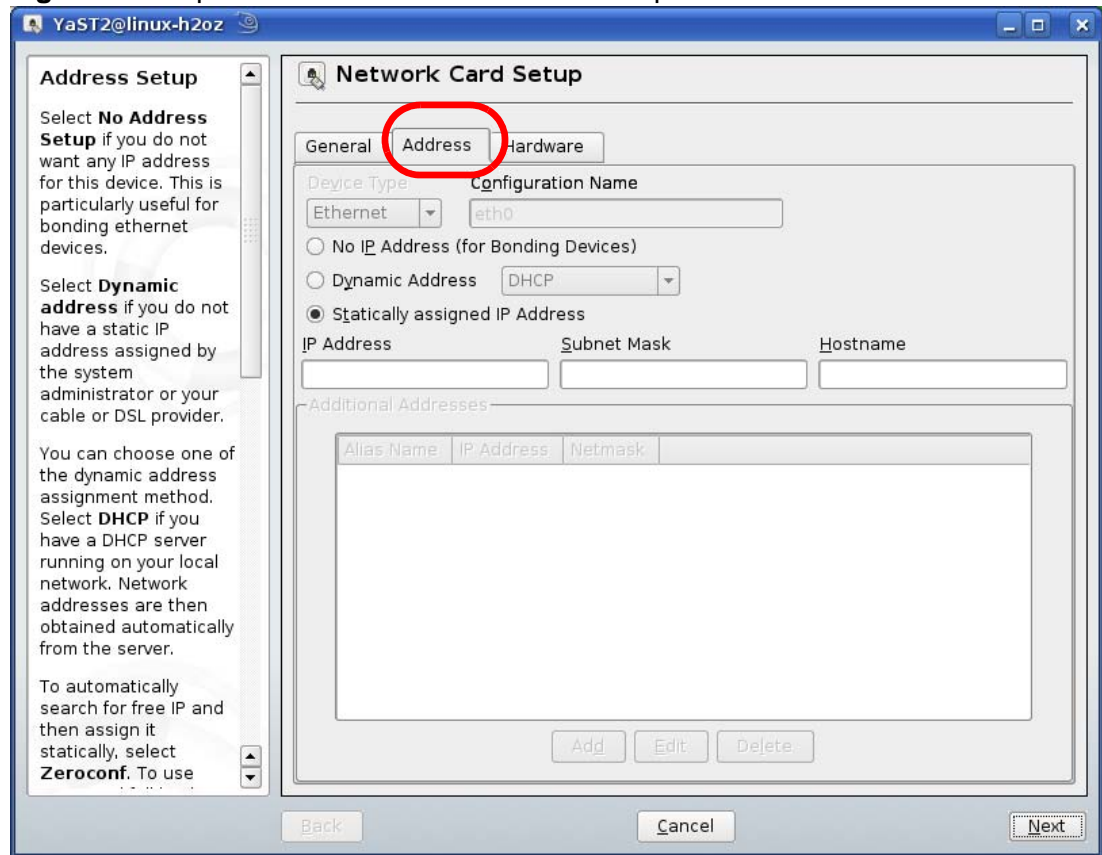

- 6 Select **Dynamic Address (DHCP)** if you have a dynamic IP address.
Select **Statically assigned IP Address** if you have a static IP address. Fill in the **IP address**, **Subnet mask**, and **Hostname** fields.
- 7 Click **Next** to save the changes and close the **Network Card Setup** window.

- 8 If you know your DNS server IP address(es), click the **Hostname/DNS** tab in **Network Settings** and then enter the DNS server information in the fields provided.

Figure 156 openSUSE 10.3: Network Settings

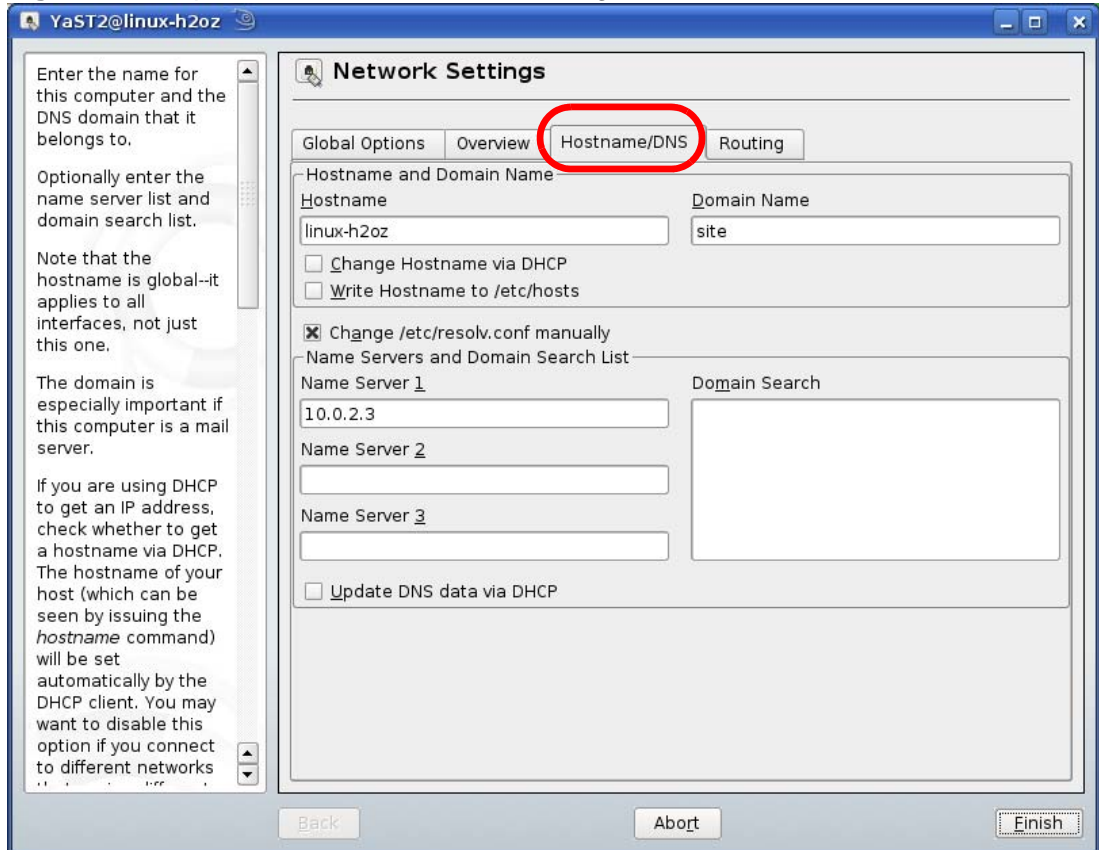

- 9 Click **Finish** to save your settings and close the window.

Verifying Settings

Click the **KNetwork Manager** icon on the **Task bar** to check your TCP/IP properties. From the **Options** sub-menu, select **Show Connection Information**.

Figure 157 openSUSE 10.3: KNetwork Manager

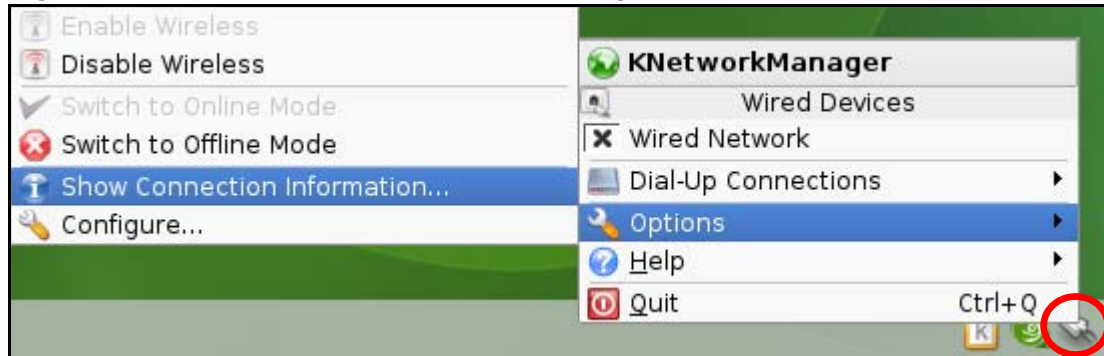

When the **Connection Status - KNetwork Manager** window opens, click the **Statistics** tab to see if your connection is working properly.

Figure 158 openSUSE: Connection Status - KNetwork Manager

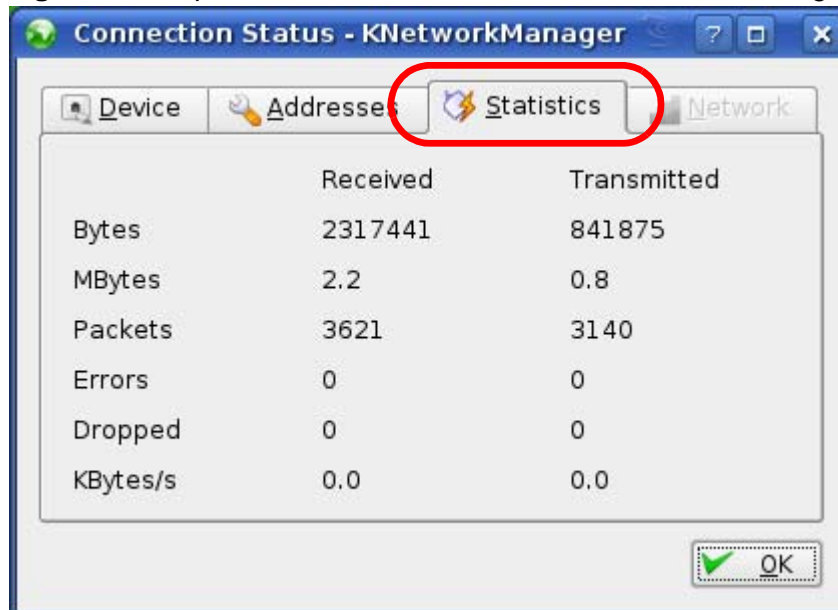

Pop-up Windows, JavaScripts and Java Permissions

In order to use the web configurator you need to allow:

- Web browser pop-up windows from your device.
- JavaScripts (enabled by default).
- Java permissions (enabled by default).

Note: Internet Explorer 6 screens are used here. Screens for other Internet Explorer versions may vary.

Internet Explorer Pop-up Blockers

You may have to disable pop-up blocking to log into your device.

Either disable pop-up blocking (enabled by default in Windows XP SP (Service Pack) 2) or allow pop-up blocking and create an exception for your device's IP address.

Disable pop-up Blockers

- 1 In Internet Explorer, select **Tools, Pop-up Blocker** and then select **Turn Off Pop-up Blocker**.

Figure 159 Pop-up Blocker

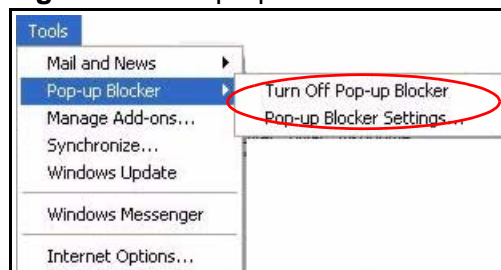

You can also check if pop-up blocking is disabled in the **Pop-up Blocker** section in the **Privacy** tab.

- 1 In Internet Explorer, select **Tools, Internet Options, Privacy**.
- 2 Clear the **Block pop-ups** check box in the **Pop-up Blocker** section of the screen. This disables any web pop-up blockers you may have enabled.

Figure 160 Internet Options: Privacy



- 3 Click **Apply** to save this setting.

Enable pop-up Blockers with Exceptions

Alternatively, if you only want to allow pop-up windows from your device, see the following steps.

- 1 In Internet Explorer, select **Tools, Internet Options** and then the **Privacy** tab.

- 2 Select **Settings...** to open the **Pop-up Blocker Settings** screen.

Figure 161 Internet Options: Privacy

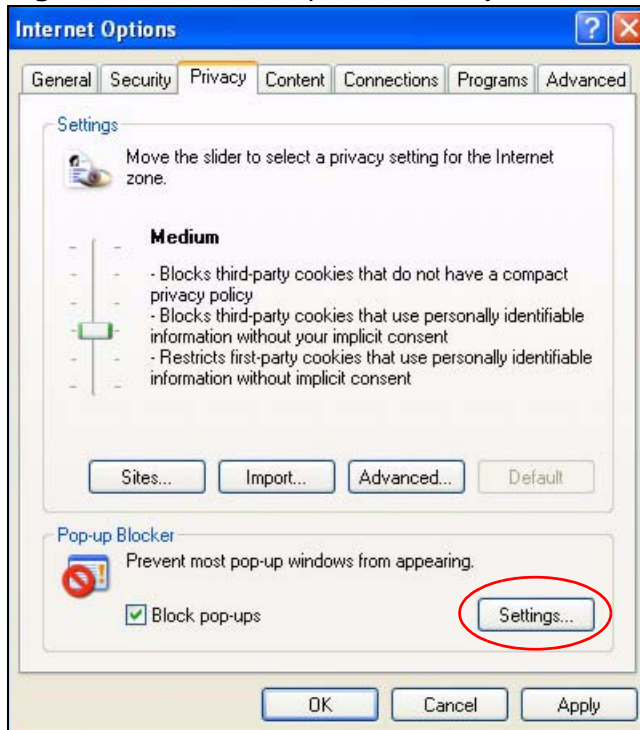

- 3 Type the IP address of your device (the web page that you do not want to have blocked) with the prefix "http://". For example, http://192.168.167.1.

- 4 Click **Add** to move the IP address to the list of **Allowed sites**.

Figure 162 Pop-up Blocker Settings

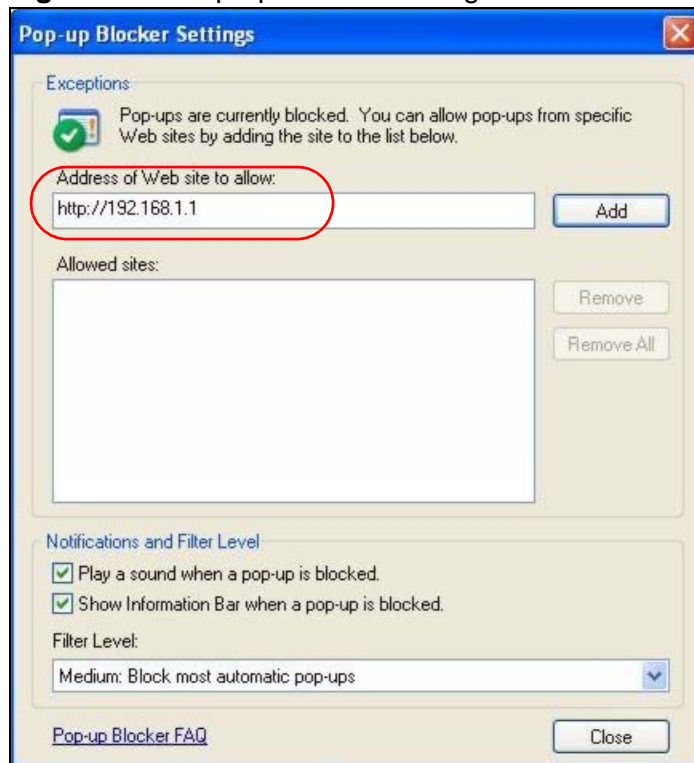

- 5 Click **Close** to return to the **Privacy** screen.
- 6 Click **Apply** to save this setting.

JavaScripts

If pages of the web configurator do not display properly in Internet Explorer, check that JavaScripts are allowed.

- 1 In Internet Explorer, click **Tools**, **Internet Options** and then the **Security** tab.

Figure 163 Internet Options: Security

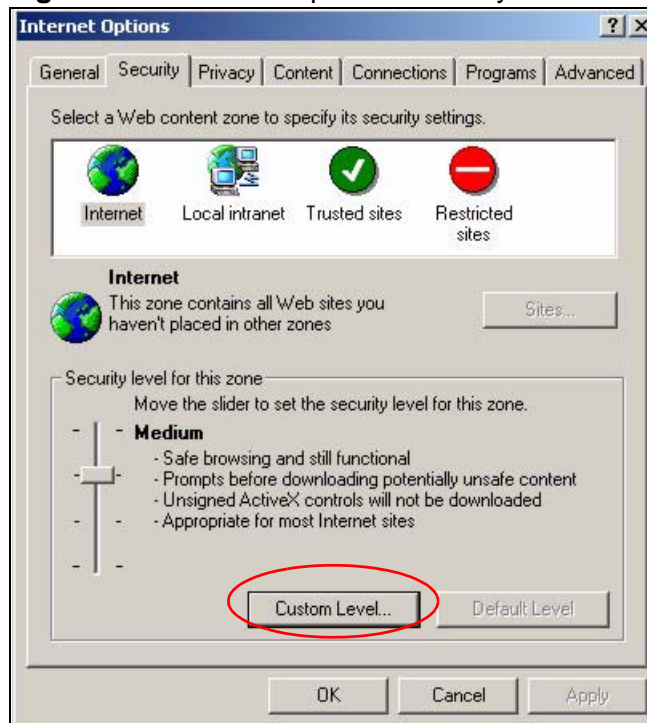

- 2 Click the **Custom Level...** button.
- 3 Scroll down to **Scripting**.
- 4 Under **Active scripting** make sure that **Enable** is selected (the default).
- 5 Under **Scripting of Java applets** make sure that **Enable** is selected (the default).

- 6 Click **OK** to close the window.

Figure 164 Security Settings - Java Scripting

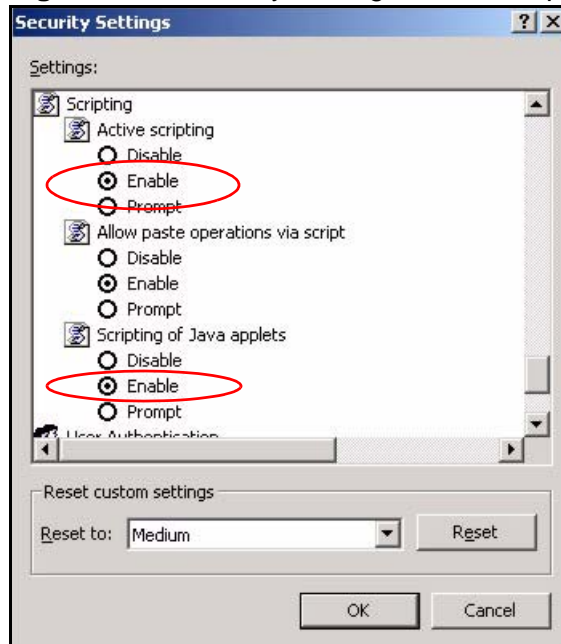

Java Permissions

- 1 From Internet Explorer, click **Tools, Internet Options** and then the **Security** tab.
- 2 Click the **Custom Level...** button.
- 3 Scroll down to **Microsoft VM**.
- 4 Under **Java permissions** make sure that a safety level is selected.

- 5 Click **OK** to close the window.

Figure 165 Security Settings - Java

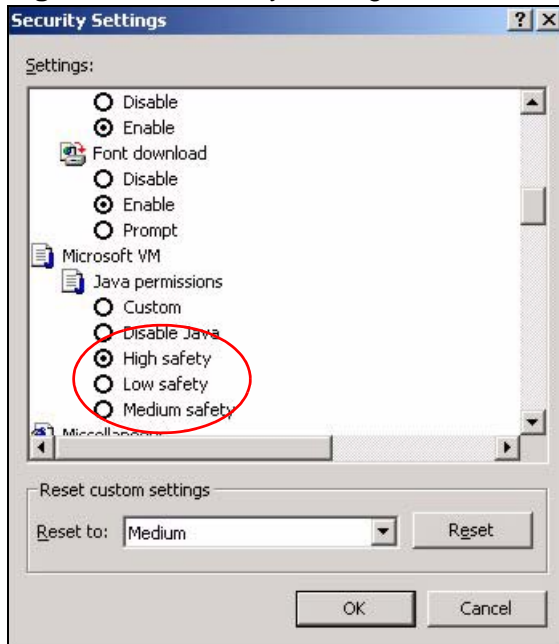

JAVA (Sun)

- 1 From Internet Explorer, click **Tools, Internet Options** and then the **Advanced** tab.
- 2 Make sure that **Use Java 2 for <applet>** under **Java (Sun)** is selected.

- 3 Click **OK** to close the window.

Figure 166 Java (Sun)

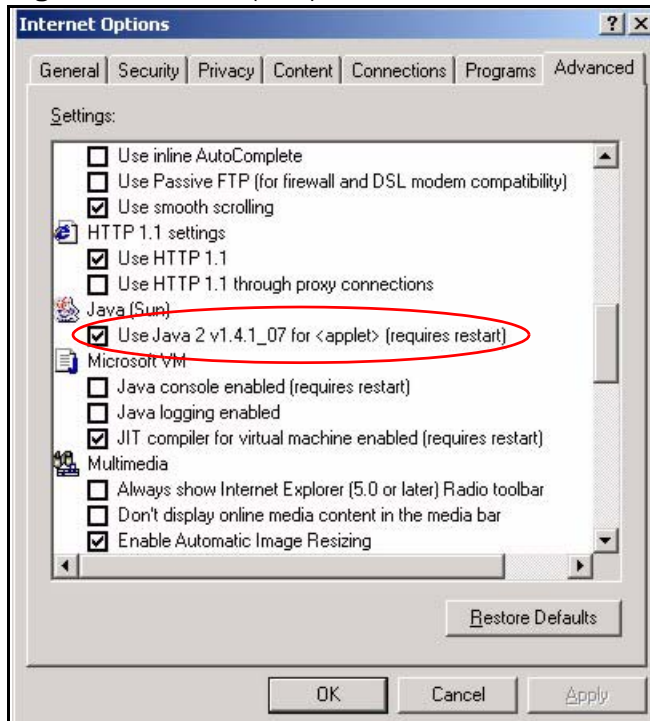

IP Addresses and Subnetting

This appendix introduces IP addresses and subnet masks.

IP addresses identify individual devices on a network. Every networking device (including computers, servers, routers, printers, etc.) needs an IP address to communicate across the network. These networking devices are also known as hosts.

Subnet masks determine the maximum number of possible hosts on a network. You can also use subnet masks to divide one network into multiple sub-networks.

Introduction to IP Addresses

One part of the IP address is the network number, and the other part is the host ID. In the same way that houses on a street share a common street name, the hosts on a network share a common network number. Similarly, as each house has its own house number, each host on the network has its own unique identifying number - the host ID. Routers use the network number to send packets to the correct network, while the host ID determines to which host on the network the packets are delivered.

Structure

An IP address is made up of four parts, written in dotted decimal notation (for example, 192.168.1.1). Each of these four parts is known as an octet. An octet is an eight-digit binary number (for example 11000000, which is 192 in decimal notation).

Therefore, each octet has a possible range of 00000000 to 11111111 in binary, or 0 to 255 in decimal.

The following figure shows an example IP address in which the first three octets (192.168.1) are the network number, and the fourth octet (16) is the host ID.

Figure 167 Network Number and Host ID

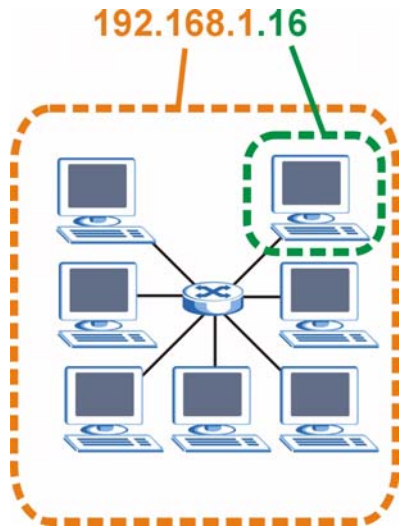

How much of the IP address is the network number and how much is the host ID varies according to the subnet mask.

Subnet Masks

A subnet mask is used to determine which bits are part of the network number, and which bits are part of the host ID (using a logical AND operation). The term “subnet” is short for “sub-network”.

A subnet mask has 32 bits. If a bit in the subnet mask is a “1” then the corresponding bit in the IP address is part of the network number. If a bit in the subnet mask is “0” then the corresponding bit in the IP address is part of the host ID.

The following example shows a subnet mask identifying the network number (in bold text) and host ID of an IP address (192.168.1.2 in decimal).

Table 52 IP Address Network Number and Host ID Example

	1ST OCTET: (192)	2ND OCTET: (168)	3RD OCTET: (1)	4TH OCTET (2)
IP Address (Binary)	11000000	10101000	00000001	00000010
Subnet Mask (Binary)	11111111	11111111	11111111	00000000
Network Number	11000000	10101000	00000001	
Host ID				00000010

By convention, subnet masks always consist of a continuous sequence of ones beginning from the leftmost bit of the mask, followed by a continuous sequence of zeros, for a total number of 32 bits.

Subnet masks can be referred to by the size of the network number part (the bits with a “1” value). For example, an “8-bit mask” means that the first 8 bits of the mask are ones and the remaining 24 bits are zeroes.

Subnet masks are expressed in dotted decimal notation just like IP addresses. The following examples show the binary and decimal notation for 8-bit, 16-bit, 24-bit and 29-bit subnet masks.

Table 53 Subnet Masks

	BINARY				DECIMAL
	1ST OCTET	2ND OCTET	3RD OCTET	4TH OCTET	
8-bit mask	11111111	00000000	00000000	00000000	255.0.0.0
16-bit mask	11111111	11111111	00000000	00000000	255.255.0.0
24-bit mask	11111111	11111111	11111111	00000000	255.255.255.0
29-bit mask	11111111	11111111	11111111	11111000	255.255.255.248

Network Size

The size of the network number determines the maximum number of possible hosts you can have on your network. The larger the number of network number bits, the smaller the number of remaining host ID bits.

An IP address with host IDs of all zeros is the IP address of the network (192.168.1.0 with a 24-bit subnet mask, for example). An IP address with host IDs of all ones is the broadcast address for that network (192.168.1.255 with a 24-bit subnet mask, for example).

As these two IP addresses cannot be used for individual hosts, calculate the maximum number of possible hosts in a network as follows:

Table 54 Maximum Host Numbers

SUBNET MASK		HOST ID SIZE		MAXIMUM NUMBER OF HOSTS
8 bits	255.0.0.0	24 bits	$2^{24} - 2$	16777214
16 bits	255.255.0.0	16 bits	$2^{16} - 2$	65534
24 bits	255.255.255.0	8 bits	$2^8 - 2$	254
29 bits	255.255.255.248	3 bits	$2^3 - 2$	6

Notation

Since the mask is always a continuous number of ones beginning from the left, followed by a continuous number of zeros for the remainder of the 32 bit mask, you can simply specify the number of ones instead of writing the value of each octet. This is usually specified by writing a "/" followed by the number of bits in the mask after the address.

For example, 192.1.1.0 /25 is equivalent to saying 192.1.1.0 with subnet mask 255.255.255.128.

The following table shows some possible subnet masks using both notations.

Table 55 Alternative Subnet Mask Notation

SUBNET MASK	ALTERNATIVE NOTATION	LAST OCTET (BINARY)	LAST OCTET (DECIMAL)
255.255.255.0	/24	0000 0000	0
255.255.255.128	/25	1000 0000	128
255.255.255.192	/26	1100 0000	192
255.255.255.224	/27	1110 0000	224
255.255.255.240	/28	1111 0000	240
255.255.255.248	/29	1111 1000	248
255.255.255.252	/30	1111 1100	252

Subnetting

You can use subnetting to divide one network into multiple sub-networks. In the following example a network administrator creates two sub-networks to isolate a group of servers from the rest of the company network for security reasons.

In this example, the company network address is 192.168.1.0. The first three octets of the address (192.168.1) are the network number, and the remaining octet is the host ID, allowing a maximum of $2^8 - 2$ or 254 possible hosts.

The following figure shows the company network before subnetting.

Figure 168 Subnetting Example: Before Subnetting

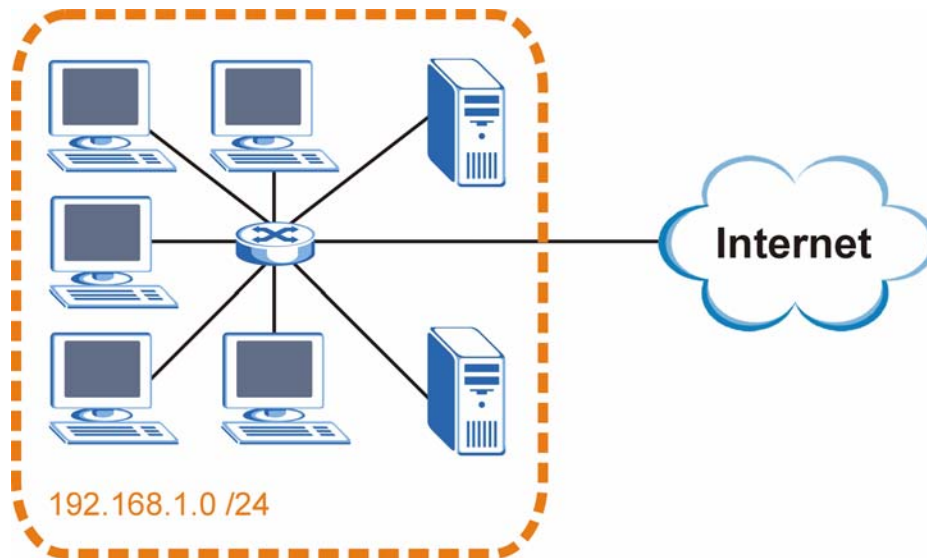

You can “borrow” one of the host ID bits to divide the network `192.168.1.0` into two separate sub-networks. The subnet mask is now 25 bits (`255.255.255.128` or `/25`).

The “borrowed” host ID bit can have a value of either 0 or 1, allowing two subnets; `192.168.1.0 /25` and `192.168.1.128 /25`.

The following figure shows the company network after subnetting. There are now two sub-networks, **A** and **B**.

Figure 169 Subnetting Example: After Subnetting

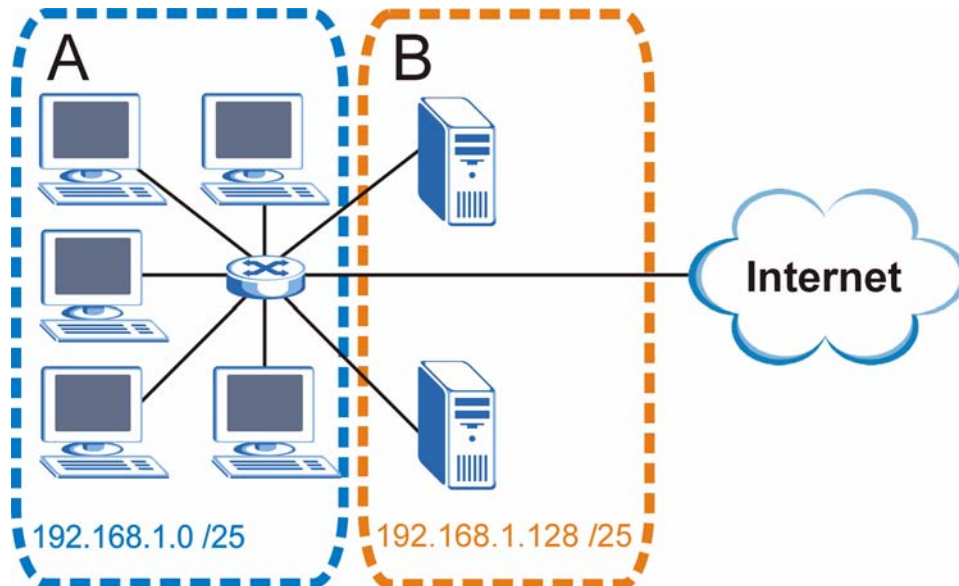

In a 25-bit subnet the host ID has 7 bits, so each sub-network has a maximum of $2^7 - 2$ or 126 possible hosts (a host ID of all zeroes is the subnet's address itself, all ones is the subnet's broadcast address).

192.168.1.0 with mask 255.255.255.128 is subnet **A** itself, and 192.168.1.127 with mask 255.255.255.128 is its broadcast address. Therefore, the lowest IP address that can be assigned to an actual host for subnet **A** is 192.168.1.1 and the highest is 192.168.1.126.

Similarly, the host ID range for subnet **B** is 192.168.1.129 to 192.168.1.254.

Example: Four Subnets

The previous example illustrated using a 25-bit subnet mask to divide a 24-bit address into two subnets. Similarly, to divide a 24-bit address into four subnets, you need to "borrow" two host ID bits to give four possible combinations (00, 01, 10 and 11). The subnet mask is 26 bits (11111111.11111111.11111111.11000000) or 255.255.255.192.

Each subnet contains 6 host ID bits, giving $2^6 - 2$ or 62 hosts for each subnet (a host ID of all zeroes is the subnet itself, all ones is the subnet's broadcast address).

Table 56 Subnet 1

IP/SUBNET MASK	NETWORK NUMBER	LAST OCTET BIT VALUE
IP Address (Decimal)	192.168.1.	0
IP Address (Binary)	11000000.10101000.00000001.	00000000
Subnet Mask (Binary)	11111111.11111111.11111111.	11000000
Subnet Address: 192.168.1.0	Lowest Host ID: 192.168.1.1	
Broadcast Address: 192.168.1.63	Highest Host ID: 192.168.1.62	

Table 57 Subnet 2

IP/SUBNET MASK	NETWORK NUMBER	LAST OCTET BIT VALUE
IP Address	192.168.1.	64
IP Address (Binary)	11000000.10101000.00000001.	01000000
Subnet Mask (Binary)	11111111.11111111.11111111.	11000000
Subnet Address: 192.168.1.64	Lowest Host ID: 192.168.1.65	
Broadcast Address: 192.168.1.127	Highest Host ID: 192.168.1.126	

Table 58 Subnet 3

IP/SUBNET MASK	NETWORK NUMBER	LAST OCTET BIT VALUE
IP Address	192.168.1.	128
IP Address (Binary)	11000000.10101000.00000001.	10000000
Subnet Mask (Binary)	11111111.11111111.11111111.	11000000
Subnet Address: 192.168.1.128	Lowest Host ID: 192.168.1.129	
Broadcast Address: 192.168.1.191	Highest Host ID: 192.168.1.190	

Table 59 Subnet 4

IP/SUBNET MASK	NETWORK NUMBER	LAST OCTET BIT VALUE
IP Address	192.168.1.	192
IP Address (Binary)	11000000.10101000.00000001. .	11000000
Subnet Mask (Binary)	11111111.11111111.11111111. .	11000000

Table 59 Subnet 4 (continued)

IP/SUBNET MASK	NETWORK NUMBER	LAST OCTET BIT VALUE
Subnet Address: 192.168.1.192	Lowest Host ID: 192.168.1.193	
Broadcast Address: 192.168.1.255	Highest Host ID: 192.168.1.254	

Example: Eight Subnets

Similarly, use a 27-bit mask to create eight subnets (000, 001, 010, 011, 100, 101, 110 and 111).

The following table shows IP address last octet values for each subnet.

Table 60 Eight Subnets

SUBNET	SUBNET ADDRESS	FIRST ADDRESS	LAST ADDRESS	BROADCAST ADDRESS
1	0	1	30	31
2	32	33	62	63
3	64	65	94	95
4	96	97	126	127
5	128	129	158	159
6	160	161	190	191
7	192	193	222	223
8	224	225	254	255

Subnet Planning

The following table is a summary for subnet planning on a network with a 24-bit network number.

Table 61 24-bit Network Number Subnet Planning

NO. "BORROWED" HOST BITS	SUBNET MASK	NO. SUBNETS	NO. HOSTS PER SUBNET
1	255.255.255.128 (/25)	2	126
2	255.255.255.192 (/26)	4	62
3	255.255.255.224 (/27)	8	30
4	255.255.255.240 (/28)	16	14
5	255.255.255.248 (/29)	32	6
6	255.255.255.252 (/30)	64	2
7	255.255.255.254 (/31)	128	1

The following table is a summary for subnet planning on a network with a 16-bit network number.

Table 62 16-bit Network Number Subnet Planning

NO. "BORROWED" HOST BITS	SUBNET MASK	NO. SUBNETS	NO. HOSTS PER SUBNET
1	255.255.128.0 (/17)	2	32766
2	255.255.192.0 (/18)	4	16382
3	255.255.224.0 (/19)	8	8190
4	255.255.240.0 (/20)	16	4094
5	255.255.248.0 (/21)	32	2046
6	255.255.252.0 (/22)	64	1022
7	255.255.254.0 (/23)	128	510
8	255.255.255.0 (/24)	256	254
9	255.255.255.128 (/25)	512	126
10	255.255.255.192 (/26)	1024	62
11	255.255.255.224 (/27)	2048	30
12	255.255.255.240 (/28)	4096	14
13	255.255.255.248 (/29)	8192	6
14	255.255.255.252 (/30)	16384	2
15	255.255.255.254 (/31)	32768	1

Configuring IP Addresses

Where you obtain your network number depends on your particular situation. If the ISP or your network administrator assigns you a block of registered IP addresses, follow their instructions in selecting the IP addresses and the subnet mask.

If the ISP did not explicitly give you an IP network number, then most likely you have a single user account and the ISP will assign you a dynamic IP address when the connection is established. If this is the case, it is recommended that you select a network number from 192.168.0.0 to 192.168.255.0. The Internet Assigned Number Authority (IANA) reserved this block of addresses specifically for private use; please do not use any other number unless you are told otherwise. You must also enable Network Address Translation (NAT) on the V300.

Once you have decided on the network number, pick an IP address for your V300 that is easy to remember (for instance, 192.168.1.1) but make sure that no other device on your network is using that IP address.

The subnet mask specifies the network number portion of an IP address. Your V300 will compute the subnet mask automatically based on the IP address that

you entered. You don't need to change the subnet mask computed by the V300 unless you are instructed to do otherwise.

Private IP Addresses

Every machine on the Internet must have a unique address. If your networks are isolated from the Internet (running only between two branch offices, for example) you can assign any IP addresses to the hosts without problems. However, the Internet Assigned Numbers Authority (IANA) has reserved the following three blocks of IP addresses specifically for private networks:

- 10.0.0.0 — 10.255.255.255
- 172.16.0.0 — 172.31.255.255
- 192.168.0.0 — 192.168.255.255

You can obtain your IP address from the IANA, from an ISP, or it can be assigned from a private network. If you belong to a small organization and your Internet access is through an ISP, the ISP can provide you with the Internet addresses for your local networks. On the other hand, if you are part of a much larger organization, you should consult your network administrator for the appropriate IP addresses.

Regardless of your particular situation, do not create an arbitrary IP address; always follow the guidelines above. For more information on address assignment, please refer to RFC 1597, *Address Allocation for Private Internets* and RFC 1466, *Guidelines for Management of IP Address Space*.

Legal Information

Copyright

Copyright © 2010 by ZyXEL Communications Corporation.

The contents of this publication may not be reproduced in any part or as a whole, transcribed, stored in a retrieval system, translated into any language, or transmitted in any form or by any means, electronic, mechanical, magnetic, optical, chemical, photocopying, manual, or otherwise, without the prior written permission of ZyXEL Communications Corporation.

Published by ZyXEL Communications Corporation. All rights reserved.

Disclaimer

ZyXEL does not assume any liability arising out of the application or use of any products, or software described herein. Neither does it convey any license under its patent rights nor the patent rights of others. ZyXEL further reserves the right to make changes in any products described herein without notice. This publication is subject to change without notice.

Trademarks

ZyNOS (ZyXEL Network Operating System) is a registered trademark of ZyXEL Communications, Inc. Other trademarks mentioned in this publication are used for identification purposes only and may be properties of their respective owners.

Certifications

Federal Communications Commission (FCC) Interference Statement

The device complies with Part 15 of FCC rules. Operation is subject to the following two conditions:

- This device may not cause harmful interference.

- This device must accept any interference received, including interference that may cause undesired operations.

This device has been tested and found to comply with the limits for a Class B digital device pursuant to Part 15 of the FCC Rules. These limits are designed to provide reasonable protection against harmful interference in a residential installation. This device generates, uses, and can radiate radio frequency energy, and if not installed and used in accordance with the instructions, may cause harmful interference to radio communications. However, there is no guarantee that interference will not occur in a particular installation.

If this device does cause harmful interference to radio/television reception, which can be determined by turning the device off and on, the user is encouraged to try to correct the interference by one or more of the following measures:

- 1 Reorient or relocate the receiving antenna.
- 2 Increase the separation between the equipment and the receiver.
- 3 Connect the equipment into an outlet on a circuit different from that to which the receiver is connected.
- 4 Consult the dealer or an experienced radio/TV technician for help.

Notices

Changes or modifications not expressly approved by the party responsible for compliance could void the user's authority to operate the equipment.

This Class B digital apparatus complies with Canadian ICES-003.

Cet appareil numérique de la classe B est conforme à la norme NMB-003 du Canada.

Viewing Certifications

- 1 Go to <http://www.zyxel.com>.
- 2 Select your product on the ZyXEL home page to go to that product's page.
- 3 Select the certification you wish to view from this page.

ZyXEL Limited Warranty

ZyXEL warrants to the original end user (purchaser) that this product is free from any defects in materials or workmanship for a period of up to two years from the

date of purchase. During the warranty period, and upon proof of purchase, should the product have indications of failure due to faulty workmanship and/or materials, ZyXEL will, at its discretion, repair or replace the defective products or components without charge for either parts or labor, and to whatever extent it shall deem necessary to restore the product or components to proper operating condition. Any replacement will consist of a new or re-manufactured functionally equivalent product of equal or higher value, and will be solely at the discretion of ZyXEL. This warranty shall not apply if the product has been modified, misused, tampered with, damaged by an act of God, or subjected to abnormal working conditions.

Note

Repair or replacement, as provided under this warranty, is the exclusive remedy of the purchaser. This warranty is in lieu of all other warranties, express or implied, including any implied warranty of merchantability or fitness for a particular use or purpose. ZyXEL shall in no event be held liable for indirect or consequential damages of any kind to the purchaser.

To obtain the services of this warranty, contact ZyXEL's Service Center for your Return Material Authorization number (RMA). Products must be returned Postage Prepaid. It is recommended that the unit be insured when shipped. Any returned products without proof of purchase or those with an out-dated warranty will be repaired or replaced (at the discretion of ZyXEL) and the customer will be billed for parts and labor. All repaired or replaced products will be shipped by ZyXEL to the corresponding return address, Postage Paid. This warranty gives you specific legal rights, and you may also have other rights that vary from country to country.

Registration

Register your product online to receive e-mail notices of firmware upgrades and information at www.zyxel.com for global products, or at www.us.zyxel.com for North American products.

Open Software Announcements

End-User License Agreement for "V300"

WARNING: ZyXEL Communications Corp. IS WILLING TO LICENSE THE SOFTWARE TO YOU ONLY UPON THE CONDITION THAT YOU ACCEPT ALL OF THE TERMS CONTAINED IN THIS LICENSE AGREEMENT. PLEASE READ THE TERMS CAREFULLY BEFORE COMPLETING THE INSTALLATION PROCESS AS INSTALLING THE SOFTWARE WILL INDICATE YOUR ASSENT TO THEM. IF YOU DO NOT AGREE TO THESE TERMS, THEN ZyXEL, IS UNWILLING TO LICENSE THE SOFTWARE TO YOU, IN WHICH EVENT YOU SHOULD RETURN THE UNINSTALLED SOFTWARE AND PACKAGING TO THE PLACE FROM WHICH IT WAS ACQUIRED OR ZyXEL, AND YOUR MONEY WILL BE REFUNDED.

1 Grant of License for Personal Use

ZyXEL Communications Corp. ("ZyXEL") grants you a non-exclusive, non-sublicense, non-transferable license to use the program with which this license is distributed (the "Software"), including any documentation files accompanying the Software ("Documentation"), for internal business use only, for up to the number of users specified in sales order and invoice. You have the right to make one backup copy of the Software and Documentation solely for archival, back-up or disaster recovery purposes. You shall not exceed the scope of the license granted hereunder. Any rights not expressly granted by ZyXEL to you are reserved by ZyXEL, and all implied licenses are disclaimed.

2 Ownership

You have no ownership rights in the Software. Rather, you have a license to use the Software as long as this License Agreement remains in full force and effect. Ownership of the Software, Documentation and all intellectual property rights therein shall remain at all times with ZyXEL. Any other use of the Software by any other entity is strictly forbidden and is a violation of this License Agreement.

3 Copyright

The Software and Documentation contain material that is protected by International Copyright Law and trade secret law, and by international treaty provisions. All rights not granted to you herein are expressly reserved by ZyXEL. You may not remove any proprietary notice of ZyXEL or any of its licensors from any copy of the Software or Documentation.

4 Restrictions

You may not publish, display, disclose, sell, rent, lease, modify, store, loan, distribute, or create derivative works of the Software, or any part thereof. You may not assign, sublicense, convey or otherwise transfer, pledge as security or otherwise encumber the rights and licenses granted hereunder with respect to the Software. Certain components of the Software, and third party open source programs included with the Software, have been or may be made available by ZyXEL listed in the below Table (collectively the "Open-Sourced Components") You may modify or replace only these Open-Sourced Components; provided that you comply with the terms of this License and any applicable licensing terms governing use of the Open-Sourced Components, which have been provided on the online electronic documents for the Software (<ftp://opensource.zyxel.com>). ZyXEL is not obligated to provide any maintenance, technical or other support for the resultant modified Software. You may not copy, reverse engineer, decompile, reverse compile, translate, adapt, or disassemble the Software, or any part thereof, nor shall you attempt to create the source code from the object code for the Software. Except as and only to the extent expressly permitted in this License, by applicable licensing terms governing use of the Open-Sourced Components, or by applicable law, you may not market, co-brand, private label or otherwise permit third parties to link to the Software, or any part thereof. You may not use the Software, or any part thereof, in the operation of a service bureau or for the benefit of any other person or entity. You may not cause, assist or permit any third party to do any of the foregoing. Portions of the Software utilize or include third party software and other copyright material. Acknowledgements, licensing terms and disclaimers for such material are contained in the online electronic documentation for the Software (<ftp://opensource.zyxel.com>), and your use of such material is governed by their respective terms. ZyXEL has provided, as part of the Software package, access to certain third party software as a convenience. To the extent that the Software contains third party software, ZyXEL has no express or implied obligation to provide any technical or other support for such software. Please contact the appropriate software vendor or manufacturer directly for technical support and customer service related to its software and products.

5 Confidentiality

You acknowledge that the Software contains proprietary trade secrets of ZyXEL and you hereby agree to maintain the confidentiality of the Software using at least as great a degree of care as you use to maintain the confidentiality of your own most confidential information. You agree to reasonably communicate the terms and conditions of this License Agreement to those persons employed by you who come into contact with the Software, and to use reasonable best efforts to ensure their compliance with such terms and conditions, including, without limitation, not knowingly permitting such persons to use any portion of the Software for the purpose of deriving the source code of the Software.

6 No Warranty

THE SOFTWARE IS PROVIDED "AS IS." TO THE MAXIMUM EXTENT PERMITTED BY LAW, ZyXEL DISCLAIMS ALL WARRANTIES OF ANY KIND, EITHER EXPRESSED OR IMPLIED, INCLUDING, WITHOUT LIMITATION, IMPLIED WARRANTIES OF MERCHANTABILITY AND FITNESS FOR A PARTICULAR PURPOSE. ZyXEL DOES NOT WARRANT THAT THE FUNCTIONS CONTAINED IN THE SOFTWARE WILL MEET ANY REQUIREMENTS OR NEEDS YOU MAY HAVE, OR THAT THE SOFTWARE WILL OPERATE ERROR FREE, OR IN AN UNINTERRUPTED FASHION, OR THAT ANY DEFECTS OR ERRORS IN THE SOFTWARE WILL BE CORRECTED, OR THAT THE SOFTWARE IS COMPATIBLE WITH ANY PARTICULAR PLATFORM. SOME JURISDICTIONS DO NOT ALLOW THE WAIVER OR EXCLUSION OF IMPLIED WARRANTIES SO THEY MAY NOT APPLY TO YOU. IF THIS EXCLUSION IS HELD TO BE UNENFORCEABLE BY A COURT OF COMPETENT JURISDICTION, THEN ALL EXPRESS AND IMPLIED WARRANTIES SHALL BE LIMITED IN DURATION TO A PERIOD OF THIRTY (30) DAYS FROM THE DATE OF PURCHASE OF THE SOFTWARE, AND NO WARRANTIES SHALL APPLY AFTER THAT PERIOD.

7 Limitation of Liability

IN NO EVENT WILL ZyXEL BE LIABLE TO YOU OR ANY THIRD PARTY FOR ANY INCIDENTAL OR CONSEQUENTIAL DAMAGES (INCLUDING, WITHOUT LIMITATION, INDIRECT, SPECIAL, PUNITIVE, OR EXEMPLARY DAMAGES FOR LOSS OF BUSINESS, LOSS OF PROFITS, BUSINESS INTERRUPTION, OR LOSS OF BUSINESS INFORMATION) ARISING OUT OF THE USE OF OR INABILITY TO USE THE PROGRAM, OR FOR ANY CLAIM BY ANY OTHER PARTY, EVEN IF ZyXEL HAS BEEN ADVISED OF THE POSSIBILITY OF SUCH DAMAGES. ZyXEL's AGGREGATE LIABILITY WITH RESPECT TO ITS OBLIGATIONS UNDER THIS AGREEMENT OR OTHERWISE WITH RESPECT TO THE SOFTWARE AND DOCUMENTATION OR OTHERWISE SHALL BE EQUAL TO THE PURCHASE PRICE, BUT SHALL IN NO EVENT EXCEED THE PRODUCT'S PRICE. BECAUSE SOME STATES/COUNTRIES DO NOT ALLOW THE EXCLUSION OR LIMITATION OF LIABILITY FOR CONSEQUENTIAL OR INCIDENTAL DAMAGES, THE ABOVE LIMITATION MAY NOT APPLY TO YOU.

8 Export Restrictions

THIS LICENSE AGREEMENT IS EXPRESSLY MADE SUBJECT TO ANY APPLICABLE LAWS, REGULATIONS, ORDERS, OR OTHER RESTRICTIONS ON THE EXPORT OF THE SOFTWARE OR INFORMATION ABOUT SUCH SOFTWARE WHICH MAY BE IMPOSED FROM TIME TO TIME. YOU SHALL NOT EXPORT THE SOFTWARE, DOCUMENTATION OR INFORMATION ABOUT THE SOFTWARE AND DOCUMENTATION WITHOUT COMPLYING WITH SUCH LAWS, REGULATIONS, ORDERS, OR OTHER RESTRICTIONS. YOU AGREE TO INDEMNIFY ZyXEL AGAINST ALL CLAIMS, LOSSES, DAMAGES, LIABILITIES, COSTS AND EXPENSES, INCLUDING REASONABLE ATTORNEYS' FEES, TO THE EXTENT SUCH CLAIMS ARISE OUT OF ANY BREACH OF THIS SECTION 8.

9 Audit Rights

ZyXEL SHALL HAVE THE RIGHT, AT ITS OWN EXPENSE, UPON REASONABLE PRIOR NOTICE, TO PERIODICALLY INSPECT AND AUDIT YOUR RECORDS TO ENSURE YOUR COMPLIANCE WITH THE TERMS AND CONDITIONS OF THIS LICENSE AGREEMENT.

10 Termination

This License Agreement is effective until it is terminated. You may terminate this License Agreement at any time by destroying or returning to ZyXEL all copies of the Software and Documentation in your possession or under your control. ZyXEL may terminate this License Agreement for any reason, including, but not limited to, if ZyXEL finds that you have violated any of the terms of this License Agreement. Upon notification of termination, you agree to destroy or return to ZyXEL all copies of the Software and Documentation and to certify in writing that all known copies, including backup copies, have been destroyed. All provisions relating to confidentiality, proprietary rights, and non-disclosure shall survive the termination of this Software License Agreement.

11 General

This License Agreement shall be construed, interpreted and governed by the laws of Republic of China without regard to conflicts of laws provisions thereof. The exclusive forum for any disputes arising out of or relating to this License Agreement shall be an appropriate court or Commercial Arbitration Association sitting in ROC, Taiwan. This License Agreement shall constitute the entire Agreement between the parties hereto. This License Agreement, the rights granted hereunder, the Software and Documentation shall not be assigned by you without the prior written consent of ZyXEL. Any waiver or modification of this License Agreement shall only be effective if it is in writing and signed by both parties hereto. If any part of this License Agreement is found invalid or unenforceable by a court of competent jurisdiction, the remainder of this License

Agreement shall be interpreted so as to reasonably effect the intention of the parties.

Note: NOTE: Some components of this product incorporate source code covered under the open source code licenses. To obtain the source code covered under those Licenses, please check ZyXEL Technical Support (support@zyxel.com.tw) to get it.

Table 63 Open Source Components

SOFTWARE	VERSION	URL
Linux	2.4.17	http://www.linux.org/info/gnu.html
busybox	0.61pre	http://www.busybox.net/license.html
MSNTP	1.6	http://www.freebsdsoftware.org/net/msntp.html
uClibc	0.9.19	http://www.uclibc.org/about.html
udhcp	0.9.7	http://freshmeat.net/projects/udhcp/
utelnetsd	0.1.4	http://sourceforge.net/projects/utelnetsd/
zlib	1.2.3	http://www.zlib.net/zlib_license.html
bftpd	1.4.1	http://bftpd.sourceforge.net/downloads/COPYING/
c-ares	1.3.1	http://c-ares.haxx.se/license.html
inadyn	1.96.2	http://www.inatech.eu/inadyn/
iptables	1.3.8	http://www.netfilter.org/about.html#license
libosip2	3.1.0	http://www.gnu.org/software/osip/
monit	5.0	http://mmonit.com/monit/
openssl	0.9.7d	http://www.openssl.org/about/
stunnel	4.15	http://www.stunnel.org/
tftp	hpa0.42	http://freshmeat.net/projects/tftp-hpa/
libupnp	1.3.1	http://upnp.sourceforge.net/
mini_httpd	1.19	http://acme.com/software/mini_httpd/
pppd	1.68	http://ppp.samba.org/ppp/README.html

Customer Support

Please have the following information ready when you contact customer support.

Required Information

- Product model and serial number.
- Warranty Information.
- Date that you received your device.
- Brief description of the problem and the steps you took to solve it.

“+” is the (prefix) number you dial to make an international telephone call.

Corporate Headquarters (Worldwide)

- Support E-mail: support@zyxel.com.tw
- Sales E-mail: sales@zyxel.com.tw
- Telephone: +886-3-578-3942
- Fax: +886-3-578-2439
- Web: www.zyxel.com, www.europe.zyxel.com
- FTP: [ftp.zyxel.com](ftp://ftp.zyxel.com), [ftp.europe.zyxel.com](ftp://ftp.europe.zyxel.com)
- Regular Mail: ZyXEL Communications Corp., 6 Innovation Road II, Science Park, Hsinchu 300, Taiwan

Costa Rica

- Support E-mail: soporte@zyxel.co.cr
- Sales E-mail: sales@zyxel.co.cr
- Telephone: +506-2017878
- Fax: +506-2015098
- Web: www.zyxel.co.cr
- FTP: [ftp.zyxel.co.cr](ftp://ftp.zyxel.co.cr)
- Regular Mail: ZyXEL Costa Rica, Plaza Roble Escazú, Etapa El Patio, Tercer Piso, San José, Costa Rica

Czech Republic

- E-mail: info@cz.zyxel.com
- Telephone: +420-241-091-350
- Fax: +420-241-091-359
- Web: www.zyxel.cz
- Regular Mail: ZyXEL Communications, Czech s.r.o., Modranská 621, 143 01 Praha 4 - Modrany, Česká Republika

Denmark

- Support E-mail: support@zyxel.dk
- Sales E-mail: sales@zyxel.dk
- Telephone: +45-39-55-07-00
- Fax: +45-39-55-07-07
- Web: www.zyxel.dk
- Regular Mail: ZyXEL Communications A/S, Columbusvej, 2860 Soeborg, Denmark

Finland

- Support E-mail: support@zyxel.fi
- Sales E-mail: sales@zyxel.fi
- Telephone: +358-9-4780-8411
- Fax: +358-9-4780-8448
- Web: www.zyxel.fi
- Regular Mail: ZyXEL Communications Oy, Malminkaari 10, 00700 Helsinki, Finland

France

- E-mail: info@zyxel.fr
- Telephone: +33-4-72-52-97-97
- Fax: +33-4-72-52-19-20
- Web: www.zyxel.fr
- Regular Mail: ZyXEL France, 1 rue des Vergers, Bat. 1 / C, 69760 Limonest, France

Germany

- Support E-mail: support@zyxel.de
- Sales E-mail: sales@zyxel.de
- Telephone: +49-2405-6909-69
- Fax: +49-2405-6909-99

- Web: www.zyxel.de
- Regular Mail: ZyXEL Deutschland GmbH., Adenauerstr. 20/A2 D-52146, Wuerselen, Germany

Hungary

- Support E-mail: support@zyxel.hu
- Sales E-mail: info@zyxel.hu
- Telephone: +36-1-3361649
- Fax: +36-1-3259100
- Web: www.zyxel.hu
- Regular Mail: ZyXEL Hungary, 48, Zoldlomb Str., H-1025, Budapest, Hungary

India

- Support E-mail: support@zyxel.in
- Sales E-mail: sales@zyxel.in
- Telephone: +91-11-30888144 to +91-11-30888153
- Fax: +91-11-30888149, +91-11-26810715
- Web: <http://www.zyxel.in>
- Regular Mail: India - ZyXEL Technology India Pvt Ltd., II-Floor, F2/9 Okhla Phase -1, New Delhi 110020, India

Japan

- Support E-mail: support@zyxel.co.jp
- Sales E-mail: zyp@zyxel.co.jp
- Telephone: +81-3-6847-3700
- Fax: +81-3-6847-3705
- Web: www.zyxel.co.jp
- Regular Mail: ZyXEL Japan, 3F, Office T&U, 1-10-10 Higashi-Gotanda, Shinagawa-ku, Tokyo 141-0022, Japan

Kazakhstan

- Support: <http://zyxel.kz/support>
- Sales E-mail: sales@zyxel.kz
- Telephone: +7-3272-590-698
- Fax: +7-3272-590-689
- Web: www.zyxel.kz
- Regular Mail: ZyXEL Kazakhstan, 43 Dostyk Ave., Office 414, Dostyk Business Centre, 050010 Almaty, Republic of Kazakhstan

Malaysia

- Support E-mail: support@zyxel.com.my
- Sales E-mail: sales@zyxel.com.my
- Telephone: +603-8076-9933
- Fax: +603-8076-9833
- Web: <http://www.zyxel.com.my>
- Regular Mail: ZyXEL Malaysia Sdn Bhd., 1-02 & 1-03, Jalan Kenari 17F, Bandar Puchong Jaya, 47100 Puchong, Selangor Darul Ehsan, Malaysia

North America

- Support E-mail: support@zyxel.com
- Sales E-mail: sales@zyxel.com
- Telephone: +1-800-255-4101, +1-714-632-0882
- Fax: +1-714-632-0858
- Web: www.us.zyxel.com
- FTP: <ftp.us.zyxel.com>
- Regular Mail: ZyXEL Communications Inc., 1130 N. Miller St., Anaheim, CA 92806-2001, U.S.A.

Norway

- Support E-mail: support@zyxel.no
- Sales E-mail: sales@zyxel.no
- Telephone: +47-22-80-61-80
- Fax: +47-22-80-61-81
- Web: www.zyxel.no
- Regular Mail: ZyXEL Communications A/S, Nils Hansens vei 13, 0667 Oslo, Norway

Poland

- E-mail: info@pl.zyxel.com
- Telephone: +48-22-333 8250
- Fax: +48-22-333 8251
- Web: www.pl.zyxel.com
- Regular Mail: ZyXEL Communications, ul. Okrzei 1A, 03-715 Warszawa, Poland

Russia

- Support: <http://zyxel.ru/support>
- Sales E-mail: sales@zyxel.ru

- Telephone: +7-095-542-89-29
- Fax: +7-095-542-89-25
- Web: www.zyxel.ru
- Regular Mail: ZyXEL Russia, Ostrovityanova 37a Str., Moscow 117279, Russia

Singapore

- Support E-mail: support@zyxel.com.sg
- Sales E-mail: sales@zyxel.com.sg
- Telephone: +65-6899-6678
- Fax: +65-6899-8887
- Web: <http://www.zyxel.com.sg>
- Regular Mail: ZyXEL Singapore Pte Ltd., No. 2 International Business Park, The Strategy #03-28, Singapore 609930

Spain

- Support E-mail: support@zyxel.es
- Sales E-mail: sales@zyxel.es
- Telephone: +34-902-195-420
- Fax: +34-913-005-345
- Web: www.zyxel.es
- Regular Mail: ZyXEL Communications, Arte, 21 5ª planta, 28033 Madrid, Spain

Sweden

- Support E-mail: support@zyxel.se
- Sales E-mail: sales@zyxel.se
- Telephone: +46-31-744-7700
- Fax: +46-31-744-7701
- Web: www.zyxel.se
- Regular Mail: ZyXEL Communications A/S, Sjöporten 4, 41764 Göteborg, Sweden

Thailand

- Support E-mail: support@zyxel.co.th
- Sales E-mail: sales@zyxel.co.th
- Telephone: +662-831-5315
- Fax: +662-831-5395
- Web: <http://www.zyxel.co.th>

- Regular Mail: ZyXEL Thailand Co., Ltd., 1/1 Moo 2, Ratchaphruk Road, Bangrak-Noi, Muang, Nonthaburi 11000, Thailand.

Ukraine

- Support E-mail: support@ua.zyxel.com
- Sales E-mail: sales@ua.zyxel.com
- Telephone: +380-44-247-69-78
- Fax: +380-44-494-49-32
- Web: www.ua.zyxel.com
- Regular Mail: ZyXEL Ukraine, 13, Pimonenko Str., Kiev 04050, Ukraine

United Kingdom

- Support E-mail: support@zyxel.co.uk
- Sales E-mail: sales@zyxel.co.uk
- Telephone: +44-1344-303044, 08707-555779 (UK only)
- Fax: +44-1344-303034
- Web: www.zyxel.co.uk
- FTP: [ftp.zyxel.co.uk](ftp://ftp.zyxel.co.uk)
- Regular Mail: ZyXEL Communications UK Ltd., 11 The Courtyard, Eastern Road, Bracknell, Berkshire RG12 2XB, United Kingdom (UK)

Index

A

AbS [107](#)
ACK message [103](#)
action keys [33](#)
address [97](#)
address assignment [97](#)
advanced settings [56, 59](#)
alphanumeric keypad [34](#)
alternative subnet mask notation [212](#)
analysis-by-synthesis [107](#)

B

backup configuration [150](#)
block list [133](#)
BYE request [103](#)

C

cable channels [37](#)
call forwarding [127](#)
calling a contact [52](#)
certifications [219](#)
 notices [220](#)
 viewing [220](#)
circuit-switched telephone networks [101](#)
Class of Service (CoS) [108](#)
client server
 SIP [103](#)
client-server protocol [103](#)
codec [106](#)
coder/decoder [106](#)
comfort noise generation [123, 167](#)
configuration
 backup [150](#)
 reset the factory defaults [152](#)

 restore [150](#)
contact information [229](#)
contact list [51, 54, 130](#)
copyright [219](#)
CoS [108](#)
custom keys [59](#)
customer support [229](#)

D

Daylight saving [141](#)
decoder [106](#)
DHCP [59, 71, 99](#)
differentiated services [108](#)
DiffServ [108](#)
DiffServ Code Point (DSCP) [108](#)
DiffServ marking rule [108](#)
dimensions [165](#)
disclaimer [219](#)
DnD [34](#)
DnD white list [135](#)
DNS [74, 100, 142](#)
Do not Disturb [34](#)
Domain Name System [74](#)
DS field [108](#)
DSCPs [108](#)
dynamic IP address [59, 71](#)
dynamic jitter buffer [167](#)

E

echo cancellation [167](#)

F

FCC interference statement [219](#)
features [31](#)
firmware [55](#)
firmware upload [147](#)
front panel [32](#)
FTP [30](#)
function keys [34](#)

G

G.168 [167](#)
G.711 [107](#)
G.723 [107](#)
G.726 [107](#)
G.729 [107](#)
gateway [55, 71](#)
group list [131](#)

H

handset [33, 36](#)
hang up [34](#)
hardware [31](#)
hardware connections [32, 83](#)
headphone socket [35](#)
headphones [35](#)
headset [34](#)
host ID [98](#)
humidity [165](#)
hybrid waveform codec [107](#)

I

IANA [97, 218](#)
IEEE 802.1Q VLAN [109](#)
Internet access [99](#)
Internet Assigned Numbers Authority
See IANA [218](#)

Internet Protocol Private Branch Exchange [28](#)
Internet Telephony Service Provider [28, 101](#)
IP address [55, 59, 83, 97, 98](#)
IP to IP Calls [29](#)
IP-PBX [28, 101](#)
ITSP [28, 101](#)

J

jitter buffer [167](#)

K

keypad [34](#)

L

LCD screen [33, 37](#)
LCD screen display settings [59](#)
logs [145](#)
loudspeaker [35](#)

M

managing the device
good habits [30](#)
using FTP. See FTP.
using SPTGEN. See SPTGEN.
mask [98](#)
Menu key [33, 52, 53](#)
message waiting indication [107](#)
mic socket [35](#)
microphone [34](#)
multimedia [101](#)
mute [34](#)
MWI [107](#)

N

NAT [217](#)
NAT (Network Address Translation) [105](#)
NAT routers [106](#)
navigation panel [86](#)
Navigator key [33](#)
network address translators [106](#)
network connections [32](#)
network number [98](#)
number keys [34](#)

O

OK response [103](#)
outbound proxy [106](#)
 SIP [106](#)
outbound proxy server [106](#)

P

password [83, 84](#)
PBX services [101](#)
PCM [107](#)
peer-to-peer calls [29](#)
per-hop behavior [108](#)
PHB (per-hop behavior) [108](#)
phone functions [31](#)
phonebook [51, 54, 127](#)
 call contact [52](#)
Phonebook key [33](#)
physical features [31](#)
PoE [36](#)
Point [29](#)
Point to Point Calls [29](#)
Point-to-Point Protocol over Ethernet [98](#)
power [36](#)
Power over Ethernet [36](#)
power specification [165](#)
PPPoE [59, 74, 98, 100](#)
 dial-up connection

private IP address [97](#)
private networks [97](#)
product registration [221](#)
proxy server
 SIP [103](#)
pulse code modulation [107](#)

Q

QoS [108, 167](#)
quality of service
 see QoS
Quick Start Guide [83](#)

R

real-time transport protocol [105](#)
rear panel [32](#)
redirect server
 SIP [104](#)
register server
 SIP [105](#)
registration
 product [221](#)
related documentation [3](#)
required bandwidth [107](#)
reset [37, 56](#)
reset button [152](#)
restart [56](#)
restore configuration [150](#)
RFC 1631 [105](#)
RFC 1889 [105](#)
RFC 3489 [106](#)
RFC 3842 [107](#)
RJ-11 [36](#)
RTP [105](#)

S

safety warnings [6](#)
screws [168](#)

see QoS
server, outbound proxy [106](#)
session initiation protocol
 see SIP
side panel [32](#)
silence suppression [123, 167](#)
SIP [101](#)
SIP account [59, 102](#)
SIP account configuration [60](#)
SIP ACK message [103](#)
SIP authentication ID [66](#)
SIP authentication password [67](#)
SIP BYE request [103](#)
SIP call progression [102](#)
SIP client [103](#)
SIP client server [103](#)
SIP identities [102](#)
SIP INVITE request [102](#)
SIP number [62, 102](#)
SIP OK response [103](#)
SIP outbound proxy [106](#)
SIP proxy server [103](#)
SIP redirect server [104](#)
SIP register server [105](#)
SIP registrar port [65](#)
SIP registrar server [64](#)
SIP server [61](#)
SIP server address [63](#)
SIP server port [63](#)
SIP servers [103](#)
SIP service domain [65, 102](#)
SIP URI [102](#)
SIP user agent [103](#)
sound quality [107](#)
speaker [34](#)
speakerphone [34](#)
speed dial [124](#)
SPTGEN [30](#)
Static IP address [71](#)
static IP address [59, 99](#)
status bar [87](#)
status screen [85](#)
STUN [106](#)

subnet [209](#)
subnet mask [55, 71, 98, 210](#)
subnetting [212](#)
syntax conventions [4](#)
system name [138](#)
System restart [152](#)

T

TCP/IP [99](#)
temperature [165](#)
The [127](#)
Time setting [140](#)
Time Zone [80](#)
title bar [86](#)
ToS [108](#)
trademarks [219](#)
Type of Service [108](#)

U

uniform resource identifier [102](#)
URL [83](#)
use NAT [106](#)
user agent, SIP [103](#)

V

VAD [123, 167](#)
virtual local area network
 see VLAN
VLAN [76, 109](#)
VLAN group [109](#)
VLAN ID [109](#)
VLAN ID tags [109](#)
VLAN tags [109](#)
voice activity detection [123, 167](#)
voice coding [106](#)
voice mail [101](#)
voice over IP

see VoIP
voicemail [34](#)
VoIP [101](#)
VoIP password [67](#)
VoIP user name [66](#)
volume [54, 55](#)
volume keys [34](#)

W

wall-mounting [36](#)
warranty [220](#)
 note [221](#)
waveform codec [107](#)
web configurator [83](#)
white list [135](#)

